

Reelmaster® 335/3500-D and 450/4500-D Cutting Units

<u>Model/Serial Range:</u>	<u>Model Numbers:</u>	<u>Serial Numbers:</u>
	03752/03753/03754	00000-99999
	03756/03741/03751	00000-00000

Subject: Reel Drive Pulley installation Procedures.

The following procedures should be used when installing The Reel Drive Pulley onto the Reel Shaft.

REEL DRIVE PULLEY INSTALLATION PROCEDURES for REELMASTER 335/3500-D and 450/4500-D Cutting Units

1. Disassemble the reel drive pulley from the reel shaft and inspect parts for damage.
2. Use Loctite® 755 (or equivalent) cleaning solvent to ensure that all grease is removed from the reel shaft and cap screw threads.
3. Assemble the reel drive pulley and key to the reel shaft. Use Loctite 271 or equivalent on the threads of the retaining cap screw. For an even stronger connection, apply RC 680 to the shaft and pulley mating surfaces.
4. Tighten the cap screw to 75 ft-lb (10.5 Kgm).
5. Install belt and adjust tension as stated in step 6 below. DO NOT use a bar between hose fittings on the motor to tighten the belt.
6. By hand, rotate the motor to tighten the belt until 1/8" (3 mm) deflection is achieved when 7 lbs. (3 Kg) of force is applied to the mid span of the belt. Tighten the reel motor mounting bolts to 25 ft-lb (4.7 Kgm). Too much tension on the belt can affect efficiency and lead to early seal failure of the reel motor.

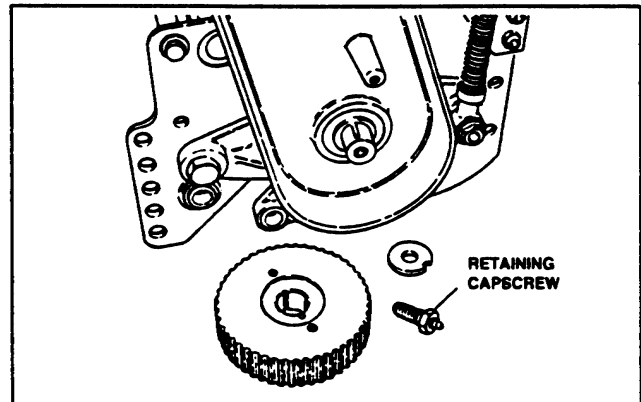

NOTE:

Debris inside the belt housing can also cause problems and damage. Check to ensure the plug is installed in the inspection hole on the cover.

