

## Toro 220 Series Brass Valves

### 1"–3" (25–75mm) Electric and 1"–3" (25–75mm) Pressure-regulating Models

#### Features

- 220 psi maximum pressure rating
- Ingot brass and stainless steel construction
- Precise pressure control option with compact EZReg™ dial-design technology (factory or field installed—no need to remove solenoid)
- Pressure regulator can be installed as a service kit without draining the main line
- Pressure regulates in electric and manual modes, serviceable under pressure
- Forward-flow design for more precise regulation
- Standard, built-in Schrader-type valve for downstream pressure verification
- Anti-vandal dust cap on pressure-regulating models

- Easily removable, self-flushing, 120-mesh, stainless steel filter screen
- No external tubing for either electric or pressure-regulating models
- Internal downstream manual bleed keeps valve box dry
- External manual bleed for system flushing
- Manual flow control: adjustable to zero flow
- Tough, double-beaded, fabric-reinforced rubber diaphragm
- Stainless steel diaphragm support ring for minimum wear
- Diaphragm stem guide
- Proven solenoid with captured hex plunger and spring
- Stainless steel solenoid seat for longer life and positive shutoff
- 18" lead wires for easy installation
- Low-power requirement for longer wire runs
- Less solenoid options for maximum flexibility
- Five-year warranty



#### Specifications

- Flow range:
  - 1"–5–40 GPM
  - 1¼"–20–100 GPM
  - 1½"–20–130 GPM
  - 2"–30–180 GPM
  - 2½"–60–250 GPM
  - 3"–80–350 GPM
- Operating pressure:
  - Electric—10–220 psi
- Pressure regulating models:
  - Outlet:
    - 5–30 psi (0,3–2,0), ± 3 psi (EZR-30)
    - 5–100 psi (0,3–7,0), ± 3 psi (EZR-100)
  - Inlet: 15–220 psi
  - Minimum pressure differential (between inlet and outlet): 10 psi
- Burst pressure safety rating: 750 psi
- Body styles:
  - Globe valve—1", 1¼", 1½", 2" female threads
  - Angle valve—2½", 3" female threads
- Solenoid: 24 V ac (standard)
  - Inrush: 0.40 amps, 11.50 VA
  - Holding: 0.20 amps, 5.75 VA
- Dimensions:
  - 1"–5¾" H x 5" W
  - 1¼"–6½" H x 6" W
  - 1½"–6½" H x 6" W
  - 2"–7½" H x 7" W
  - 2½"–8¾" H x 8½" W
  - 3"–8¾" H x 8½" W

**Note:** Not recommended for some recycled water applications. The Toro P-220 Series is a suitable alternative.

Manual flow control

Combined internal and external (flush) manual bleed screw

Solenoid with captured hex plunger and spring

Stainless steel solenoid seat

EZReg pressure-regulating module or port plug

Stainless steel diaphragm support ring

Externally removable self-flushing, 120-mesh filter screen

Standard Schrader valve for operating pressure readings

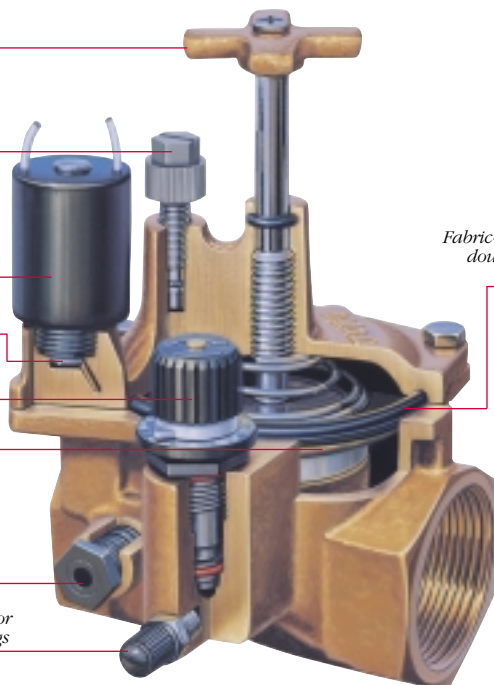

220 Series

### Specifying Information

Configuration	Solenoid	Size
3—BSP, Electric	0—60 Hz Solenoid	4—1" (25mm)
4—BSP, Pressure-regulated (5-100)	5—50 Hz Solenoid	5—1¼" (32mm)
6—NPT, Electric	6—Less Solenoid	6—1½" (40mm)
7—NPT, Pressure-regulated (5-100)		8—2" (50mm)
		9—2½" (65mm)
		0—3" (75mm)

**Example:** A 1" (25mm) NPT pressure-regulated, 220 Series Brass Valve with 60 Hz solenoid, would be specified as: **220-27-04**

**Note:** Less solenoid available in 1", 1½", 2" and 3" (25, 40, 50 and 75mm) electric NPT and BSP versions only. 1", 1½" and 2" (25, 40 and 50mm)—globe configuration. 2½" and 3" (65 and 75mm)—angle configuration. EZReg is a trademark of The Toro Company.

**Optional Accessories:**

- DC Latching solenoid assembly (E2002)
- 24VDC solenoid assembly (R576804)
- Recycled water lavender solenoid assembly and tag (RW60-Kit)
- 24 V ac potted solenoid assembly (89-9580)
  - 50–60 Hz, 24" leads
  - Inrush: 0.37 amps, 8.80 VA
  - Holding: 0.30 amps, 7.20 VA
- EZR-30 (5–30 psi pressure-regulation module)
- EZR-100 (5–100 psi pressure-regulation module)

**220 Series Friction Loss Data—U.S.**

Model	Type	GPM Flow																		
		5	10	15	20	30	40	50	60	70	80	100	120	150	170	180	200	250	300	350
1" (25mm)	Electric	2.0	2.5	1.5	2.5	5.5	7.0													
1¼" (32mm)	Electric				5.5	6.5	7.5	8.0	8.5	9.0	13.0	16.0								
1½" (40mm)	Electric				4.0	5.2	5.4	6.0	6.5	7.0	8.0	10.0	15.0							
2" (50mm)	Electric					1.0	2.0	2.0	2.5	3.0	3.5	6.0	7.5	10.0	12.0	14.0				
2½" (65mm)	Electric								2.0	2.2	2.3	2.4	2.5	3.0	4.0	4.5	5.5	7.0		
3" (75mm)	Electric										2.2	2.4	2.5	3.0	4.0	4.5	5.5	6.5	7.0	7.5

*Notes: For optimum performance when designing a system, calculate total friction loss to ensure sufficient downstream pressure. For optimum regulation performance, size regulating valves toward the higher flow ranges. Values shown in psi.*

**220 Series Friction Loss Data—Metric**

Model	Type	LPM Flow																			
		25	50	75	100	125	150	200	250	300	350	400	450	500	600	700	800	900	1000	1200	1400
25mm (1")	Electric	0,15	0,13	0,17	0,31	0,41	0,48														
32mm (1¼")	Electric			0,38	0,42	0,47	0,51	0,56	0,61	0,88	1,03										
40mm (1½")	Electric			0,32	0,33	0,36	0,37	0,42	0,47	0,55	0,64	0,79	1,02								
50mm (2")	Electric					0,09	0,14	0,15	0,19	0,24	0,35	0,44	0,51	0,59	0,75	1,00					
65mm (2½")	Electric								0,15	0,16	0,16	0,17	0,17	0,19	0,24	0,33	0,40	0,46			
75mm (3")	Electric									0,16	0,16	0,17	0,17	0,19	0,24	0,33	0,40	0,43	0,46	0,49	0,53

*Notes: For optimum performance when designing a system, calculate total friction loss to ensure sufficient downstream pressure. For optimum regulation performance, size regulating valves toward the higher flow ranges. Values shown in bar.*

**Precise Pressure Regulation**

An accurate and visibly adjustable dial, coupled with a forward-flow valve design allows the 220 Series with the EZReg module to regulate with precision. It can regulate with flows of only 5 GPM (1" valve) and it only requires 10 psi differential to operate. The pressure regulator is perfect for retrofit projects and can be easily and quickly installed—even under pressure, with no danger of water geysers from the removed solenoid area or opening of the valve. The EZReg regulates in the manual mode, should power be unavailable. A standard, Schrader-type valve permits quick verification of downstream operating pressure.



**Dirty Water Resistance**

The 220/210 Series 120-mesh, stainless steel filter screen is positioned on the supply side of the water stream. It is constantly flushed by the flow, enabling the use of very dirty water without clogging and valve closure failure. Stainless steel construction of both the filter screen and the valve solenoid seat ensure long component life in all types of water and pressures. In addition, the filter screen is easily removed for cleaning and there are no bulky tubes that can break or deteriorate.

