



Count on it.

Parts Catalog

**21in Heavy-Duty
Recycler®/Rear Bagger Lawn Mower**

Model No. 22290—Serial No. 316000001 and Up



Ordering Replacement Parts

To order replacement parts, please supply the part number, the quantity, and the description of each part desired.

Understanding Reference Numbers

Each identified part in an illustration has a reference number. The reference number for a part also appears in the parts list, along with other information about the part.

This catalog uses two special reference number formats, one to indicate parts in a service assembly and another to indicate the quantity of a given part in an illustration.

Service Assembly Reference Numbers

Parts in service assemblies have reference numbers in the form a:b. The a represents the reference number of the entire service assembly and the b represents a sequential number unique to each part within the service assembly.

For example, a wheel assembly might be identified by reference number 6, the tire by 6:1, the valve by 6:2, and the wheel by 6:3. When you order the assembly identified by reference number 6, you receive all parts identified by reference numbers 6:1, 6:2, and 6:3. However, you may also order any part individually. Reference numbers of this type appear in illustration and in parts lists.

Reference Numbers Indicating Quantity

In an illustration, if a reference number indicates more than one part, the reference number has the form nX y. The n represents the quantity of the part, the X is the multiplication symbol, and the y represents the reference number.

For example, in an illustration, the reference number 2X 37 means that two of the parts identified by reference number 37 are indicated.

List of Abbreviations

AR: as required

ASM: assembly

BBC: blade brake control

BHTF: button head thread forming

CARR: carriage

CCW: counter clockwise

CW: clockwise

DEG: degrees

DPA: Dual Point Adjustment

ECM: electronic control module

EXT: external

FH: flat head

GA: gauge

HD: heavy-duty

HF: hex flange

HH: hex head

HHF: hex head flange

HHFTF: hex head flange thread forming

HJ: hex jam

HLH: hex lag head

HOC: height-of-cut

HP: high pressure

HSBH: hex socket button head

HSFH: hex socket flat head

HSH: hex socket head

HWH: hex washer head

HWHTF: hex washer head thread forming

HYD: hydraulic

LH: left hand

LP: low pressure

LPG: Liquefied Petroleum Gas

NI: nylon insert

NPTF: national pipe thread fine

PFH: phillips flat head

PPH: phillips pan head

PPHTF: phillips pan head thread forming

PRH: phillips round head

PTH: phillips truss head

PTO: power-take-off

RH: right hand

ROPS: roll-over protection system

RRB: rear roller brush

SFH: slotted fillister head

SHH: slotted hex head

SHWH: slotted hex washer head

SPH: slotted pan head

SQH: square head

SRH: slotted round head

STD: standard

TAP: self tapping

TTH: torx truss head

Contents

Housing Assembly	4
Grass Bag Assembly	6
Engine and Blade Assembly	8
Height-of-Cut and Wheel Assembly	10
Transmission and Rear Wheel Assembly	12
Handle and Control Assembly	14
Attachments and Accessories	16

Housing Assembly

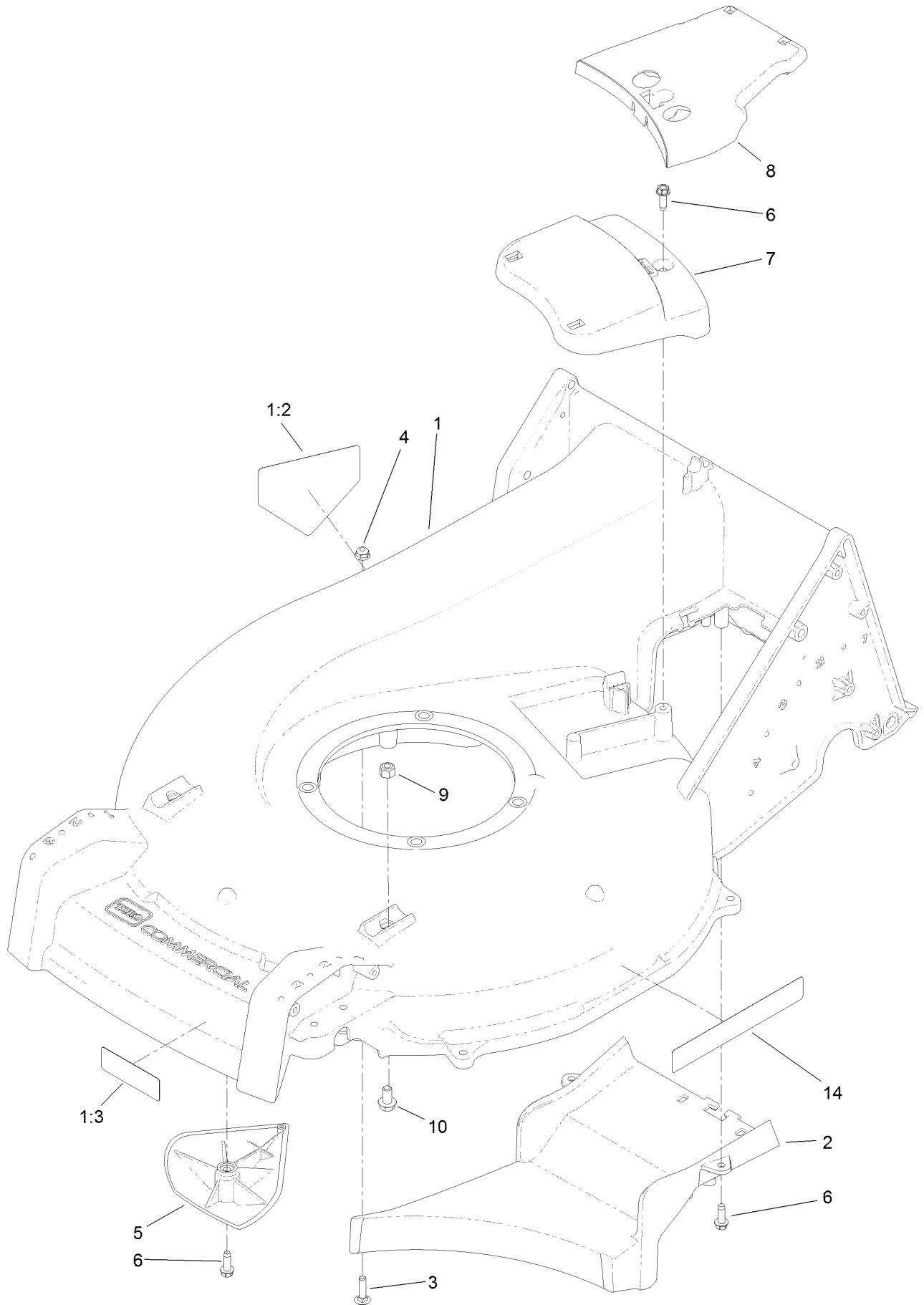

Housing Assembly (continued)

<i>Ref.</i>	<i>Part Number</i>	<i>Qty.</i>	<i>Description</i>	<i>Ref.</i>	<i>Part Number</i>	<i>Qty.</i>	<i>Description</i>
1	125-8400	1	Housing ASM	6	49-2040	5	Screw-HWHTF
1:2	94-8072	1	Decal-Danger	7	125-5038	1	Cover-Belt, Front
1:3	130-9670	1	Decal-Warning, Blade	8	125-8380	1	Cover-Belt, Rear
2	125-1002-01	1	Floor-Chute	9	3296-29	2	Nut-Lock, NI
3	3229-2	1	Screw-CARR	10	3234-7	2	Screw-HHF
4	104-7201	1	Nut-Flange, NI	14	119-2368	2	Decal-Recycler
5	125-5041	2	Kicker				

Grass Bag Assembly

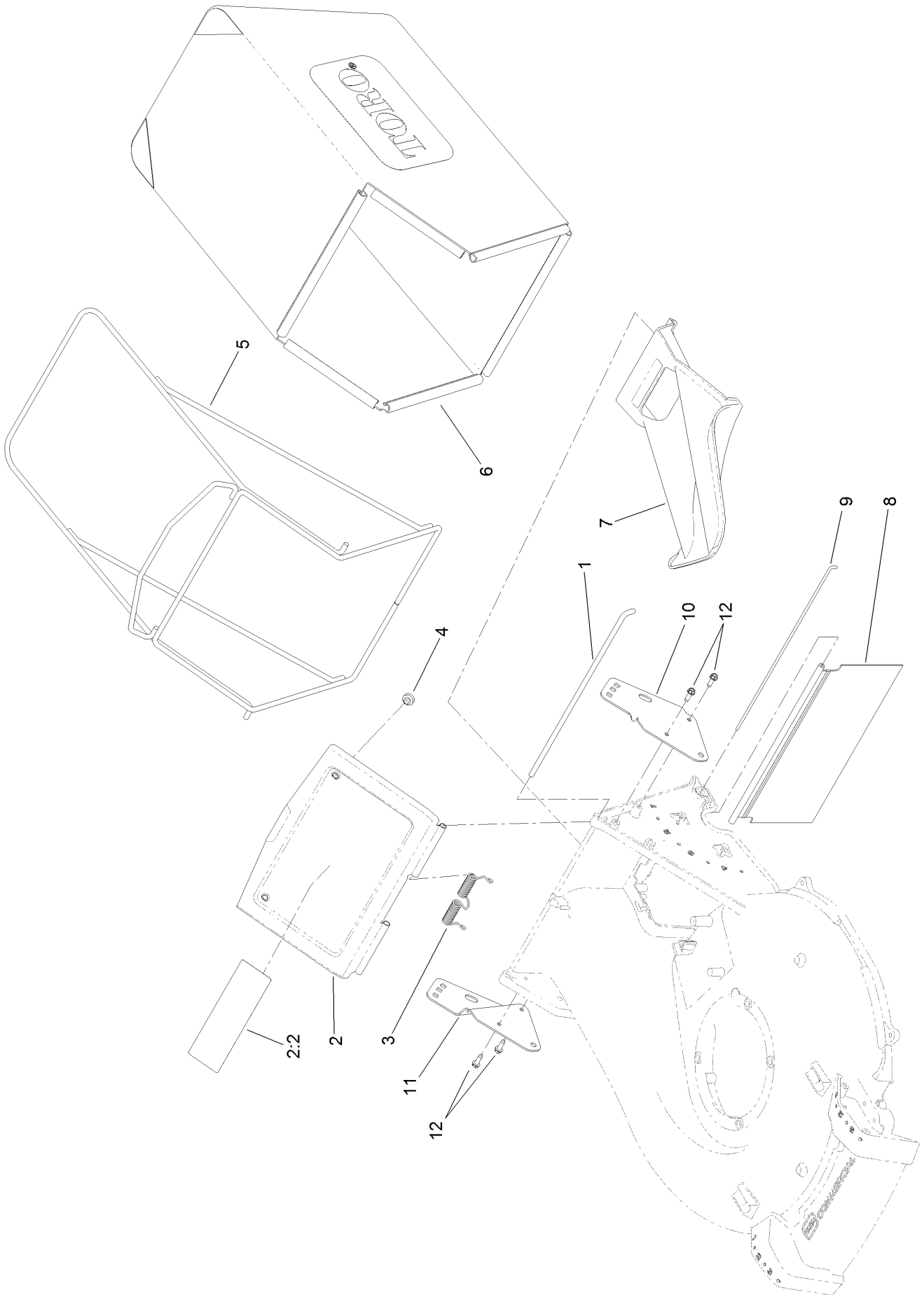

Grass Bag Assembly (continued)

<i>Ref.</i>	<i>Part Number</i>	<i>Qty.</i>	<i>Description</i>	<i>Ref.</i>	<i>Part Number</i>	<i>Qty.</i>	<i>Description</i>
1	125-1017	1	Rod-Door, Bag	7	125-1008	1	Plug-Mulch
2	125-8402	1	Bag Door ASM	8	125-1007	1	Shield-Trailing
2:2	116-7583	1	Decal-Warning	9	125-8413	1	Rod-Shield, Trailing
3	125-1019	1	Spring-Torsion	10	125-1013-03	1	Bracket-Mount, LH Handle
4	1-513658	2	Bumper	11	125-1014-03	1	Bracket-Mount, RH Handle
5	121-1399-03	1	Frame-Bag	12	49-2040	4	Screw-HWHTF
6	125-1030	1	Bag-Grass				

Engine and Blade Assembly

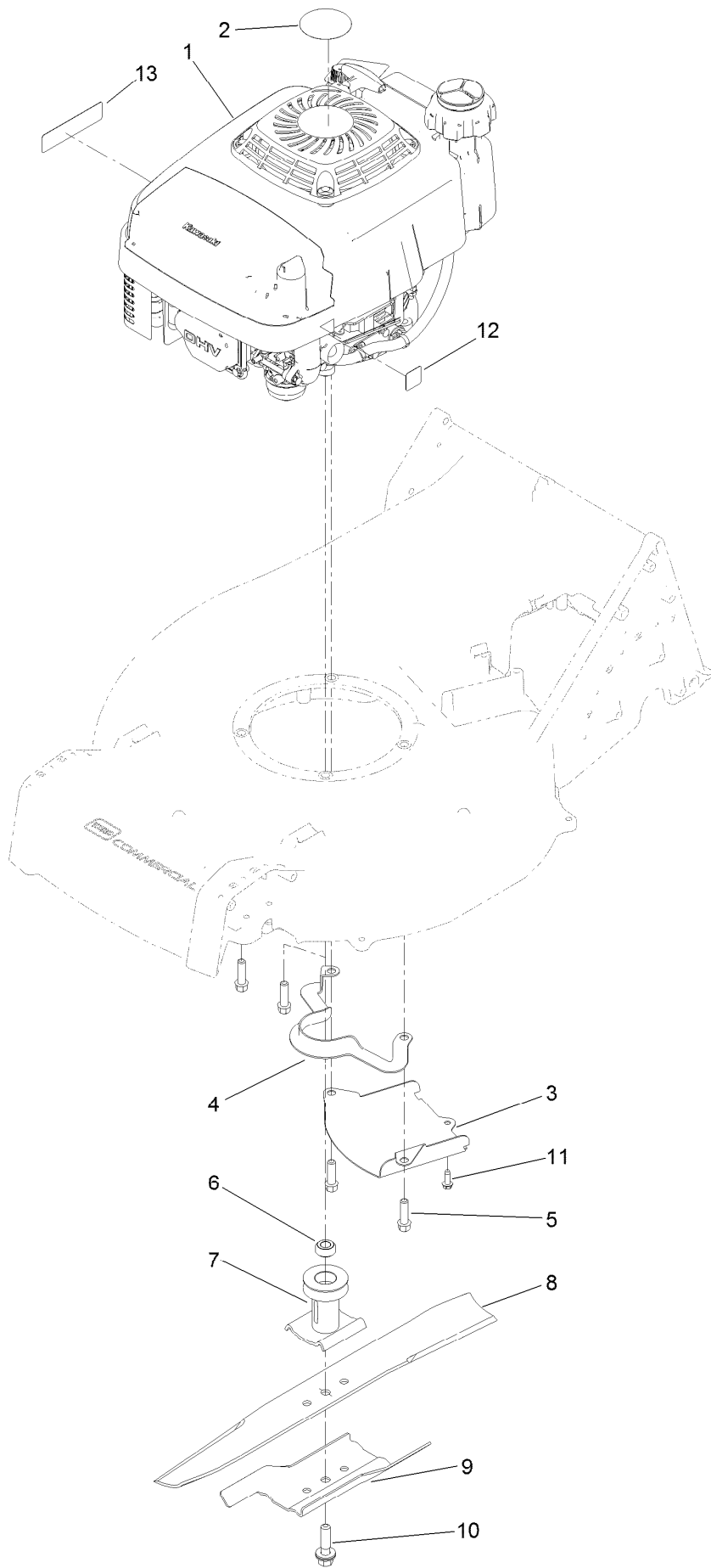

Engine and Blade Assembly (continued)

<i>Ref.</i>	<i>Part Number</i>	<i>Qty.</i>	<i>Description</i>	<i>Ref.</i>	<i>Part Number</i>	<i>Qty.</i>	<i>Description</i>
1	121-1407	1	Engine-Kawasaki, Fj180V ●	8	108-3762-03	1	Blade-Recycling
2	110-0520	1	Decal	9	125-1069-03	1	Accelerator-Blade
3	125-1005-03	1	Shield-Grass	10	125-2466	1	Bolt-Blade
4	108-8110-03	1	Guide-Belt	11	49-2040	1	Screw-HWHTF
5	95-1727	4	Screw-Taptite	12	125-8403	1	Decal-Primer
6	125-8432	1	Spacer-Driver, Blade	13	117-2718	1	Decal-Arrester, Spark
7	106-3987	1	Driver-Blade				

● Obtain parts from www.kawpowerepc.com

Height-of-Cut and Wheel Assembly

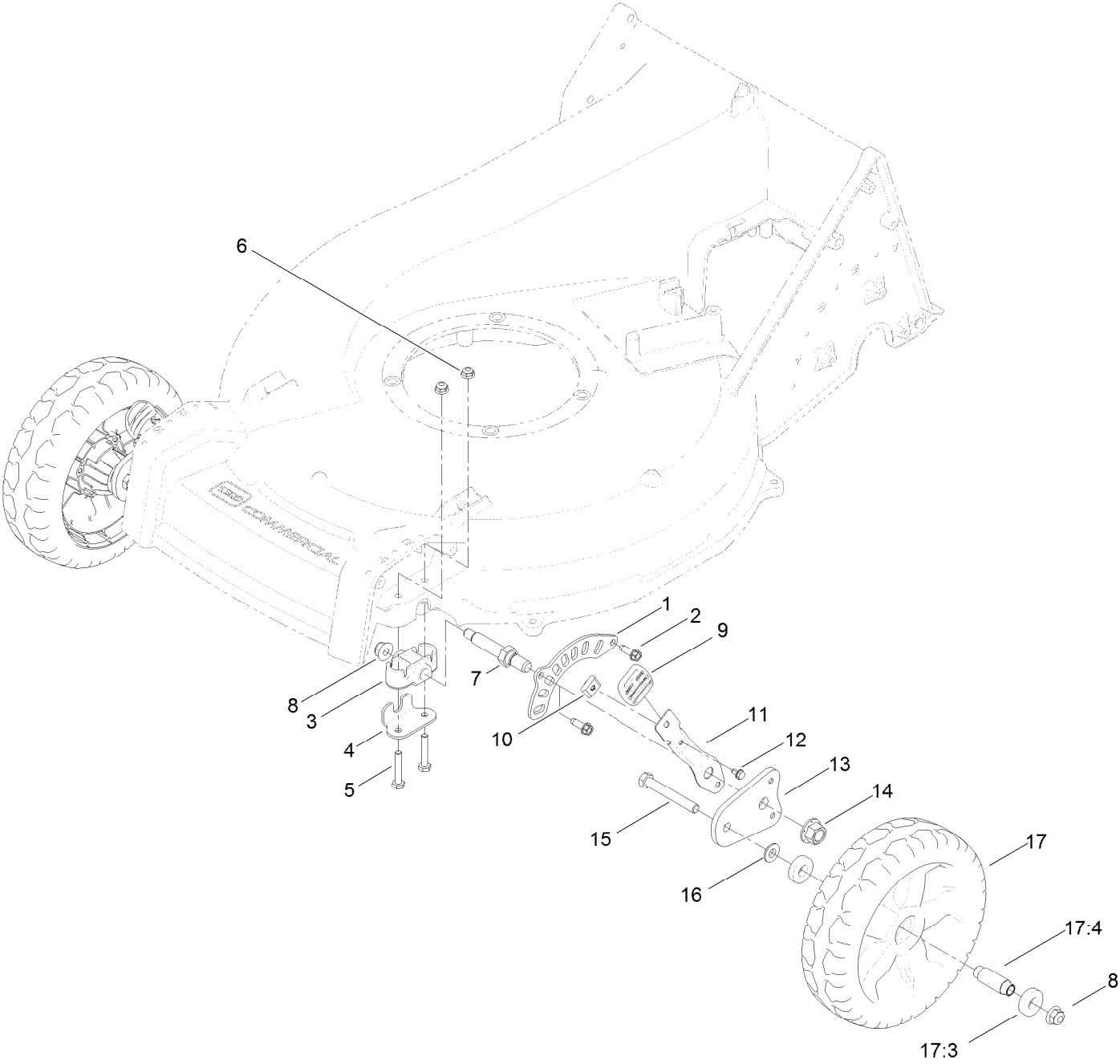

Height-of-Cut and Wheel Assembly (continued)

<i>Ref.</i>	<i>Part Number</i>	<i>Qty.</i>	<i>Description</i>	<i>Ref.</i>	<i>Part Number</i>	<i>Qty.</i>	<i>Description</i>
1	121-1439	2	Plate-HOC, Front	10	131-5377	2	Key-Arm, Spring
2	49-2040	4	Screw-HWHTF	11	121-1431-03	2	Arm-Spring
3	121-1427	2	Bushing-Axle, Front HOC	12	104-2065	2	Screw-HWH
4	121-1442	2	Retainer-Bushing, Front Axle	13	130-6420	2	Arm-Pivot, Front
5	321-37	4	Screw-HH	14	99-5107	2	Nut-Lock
6	104-7201	4	Nut-Flange, NI	15	323-13	2	Screw-HH
7	121-1428	2	Axle-Wheel	16	74-1671	2	Spacer-Cover, Wheel
8	104-8301	4	Nut-Flange, NI	17	125-1080	2	Wheel
9	125-1093	2	Knob-Lever, HOC	17:3	52-2450	2	Bearing-Wheel
				17:4	125-1077	1	Spacer

Transmission and Rear Wheel Assembly

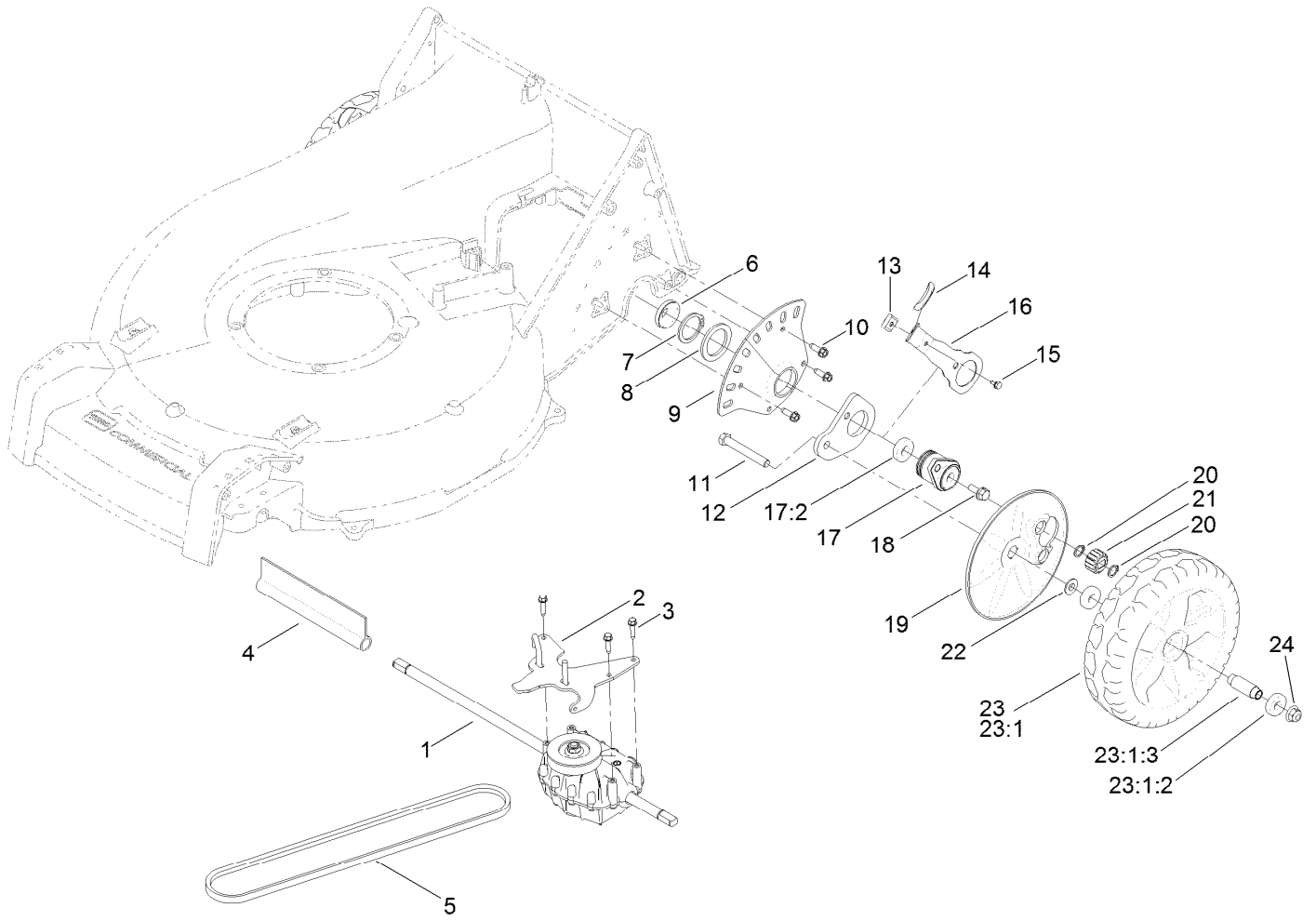

Transmission and Rear Wheel Assembly (continued)

<i>Ref.</i>	<i>Part Number</i>	<i>Qty.</i>	<i>Description</i>	<i>Ref.</i>	<i>Part Number</i>	<i>Qty.</i>	<i>Description</i>
1	125-1020	1	Transmission	15	104-2065	2	Screw-HWH
2	125-8430-03	1	Guide-Belt	16	121-1448-03	2	Arm-Spring, Rear
3	27-0220	3	Screw-Special	17	133-2604	2	Bearing Retainer ASM
4	130-9681	1	Cover-Shaft, Transmission	17:2	133-2603	4	Bearing-Ball
5	125-8395	1	Belt-V	18	130-9692	2	Screw-HWH
6	127-6848	2	Cover-Bearing	19	125-1082	2	Cover-Wheel
7	32151-10	2	Ring-Retaining	20	32151-61	4	Ring-Retaining
8	98-1452	2	Washer-Thrust	21	131-5399	2	Gear-Pinion, 15T
9	130-6422	2	Plate-HOC, Rear	22	74-1671	2	Spacer-Cover, Wheel
10	49-2040	6	Screw-HWHTF	23	133-2634	2	Wheel ASM
11	323-13	2	Screw-HH	23:1		1	Wheel ●
12	133-2641	2	Arm-Pivot, Rear	23:1:2	133-2603	2	Bearing-Ball
13	131-5377	2	Key-Arm, Spring	23:1:3	125-1077	1	Spacer
14	125-1093	2	Knob-Lever, HOC	24	104-8301	2	Nut-Flange, NI

● Not serviced separately

Handle and Control Assembly

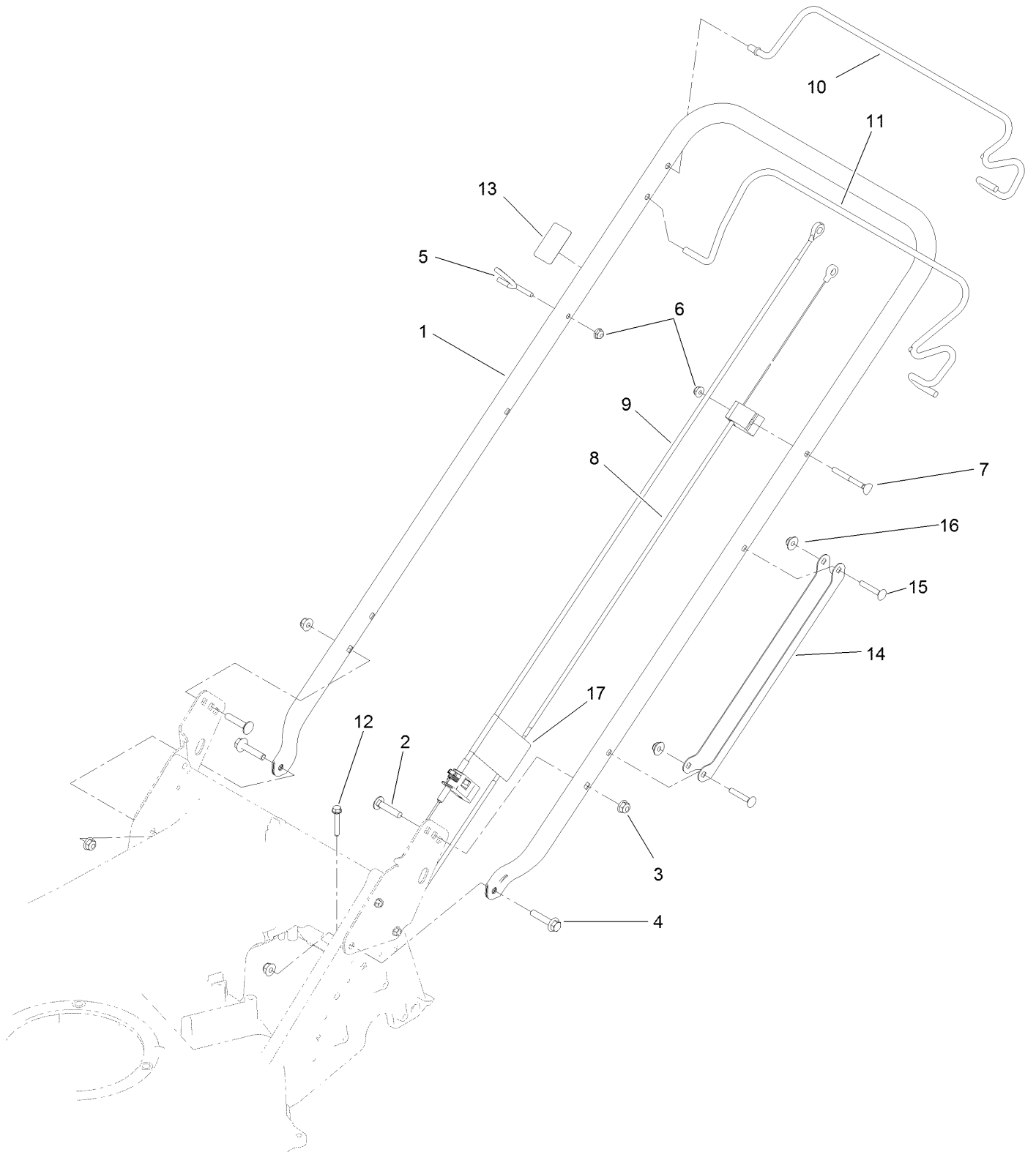

Handle and Control Assembly (continued)

<i>Ref.</i>	<i>Part Number</i>	<i>Qty.</i>	<i>Description</i>	<i>Ref.</i>	<i>Part Number</i>	<i>Qty.</i>	<i>Description</i>
1	125-1015-03	1	Handle	10	125-8437-03	1	Bail-Traction
2	3230-4	2	Screw-CARR	11	125-8436-03	1	Bail-Brake
3	104-8300	4	Nut-Flange, NI	12	94-2691	1	Screw-HWH
4	115-1794	2	Screw-HHF	13	125-8404	1	Decal-Primer
5	114-2775	1	Guide-Rope	14	127-6897-03	1	Guard-Cable, Handle
6	104-7201	2	Nut-Flange, NI	15	108-0988	2	Screw-CARR
7	92-2270	1	Screw-Handle	16	114-3778	2	Nut-Lock, NI
8	125-8371	1	Cable-Brake	17	130-6722	1	Decal-Adjust, Self Propel Drive
9	125-8372	1	Cable-Traction				

Attachments and Accessories

For 22290 21in Heavy-Duty Recycler/Rear Bagger Lawn Mower

Product Name	Model/Part
Blade-Bagging, 21in	125-1072-03
Cup-Anti Scalp.....	125-8440
Engine Guard Kit	130-9700
Deck Side Guard Kit	130-9701
Rear Discharge Kit.....	130-9734

Notes:

Notes:

Notes:



Count on it.