



Count on it.

Parts Catalog

HoverPro® 550 Machine

Model No. 02606—Serial No. 315000001 and Up



Ordering Replacement Parts

To order replacement parts, please supply the part number, the quantity, and the description of each part desired.

Understanding Reference Numbers

Each identified part in an illustration has a reference number. The reference number for a part also appears in the parts list, along with other information about the part.

This catalog uses two special reference number formats, one to indicate parts in a service assembly and another to indicate the quantity of a given part in an illustration.

Service Assembly Reference Numbers

Parts in service assemblies have reference numbers in the form a:b. The a represents the reference number of the entire service assembly and the b represents a sequential number unique to each part within the service assembly.

For example, a wheel assembly might be identified by reference number 6, the tire by 6:1, the valve by 6:2, and the wheel by 6:3. When you order the assembly identified by reference number 6, you receive all parts identified by reference numbers 6:1, 6:2, and 6:3. However, you may also order any part individually. Reference numbers of this type appear in illustration and in parts lists.

Reference Numbers Indicating Quantity

In an illustration, if a reference number indicates more than one part, the reference number has the form nX y. The n represents the quantity of the part, the X is the multiplication symbol, and the y represents the reference number.

For example, in an illustration, the reference number 2X 37 means that two of the parts identified by reference number 37 are indicated.

List of Abbreviations

AR: as required

ASM: assembly

BBC: blade brake control

BHTF: button head thread forming

CARR: carriage

CCW: counter clockwise

CW: clockwise

DEG: degrees

DPA: Dual Point Adjustment

ECM: electronic control module

EXT: external

FH: flat head

GA: gauge

HD: heavy-duty

HF: hex flange

HH: hex head

HHF: hex head flange

HHFTF: hex head flange thread forming

HJ: hex jam

HLH: hex lag head

HOC: height-of-cut

HP: high pressure

HSBH: hex socket button head

HSFH: hex socket flat head

HSH: hex socket head

HWH: hex washer head

HWHTF: hex washer head thread forming

HYD: hydraulic

LH: left hand

LP: low pressure

LPG: Liquefied Petroleum Gas

NI: nylon insert

NPTF: national pipe thread fine

PFH: phillips flat head

PPH: phillips pan head

PPHTF: phillips pan head thread forming

PRH: phillips round head

PTH: phillips truss head

PTO: power-take-off

RH: right hand

ROPS: roll-over protection system

RRB: rear roller brush

SFH: slotted fillister head

SHH: slotted hex head

SHWH: slotted hex washer head

SPH: slotted pan head

SQH: square head

SRH: slotted round head

STD: standard

TAP: self tapping

TTH: torx truss head

Contents

Engine and Deck Assembly	4
Handle Assembly	6
Cutting Assembly	8
Cylinder Barrel Assembly	10
Oil Pan Assembly	12
Crankshaft Assembly	14
Piston and Connecting Rod Assembly	16
Camshaft Pulley Assembly	18
Recoil Starter Assembly	20
Fuel Tank and Fuel Pump Assembly	22
Carburetor Assembly	24
Air Cleaner Assembly	26
Muffler Assembly	28
Flywheel and Ignition Coil Assembly	30
Control Assembly	32
Label Assembly	34
Attachments and Accessories	36

Engine and Deck Assembly

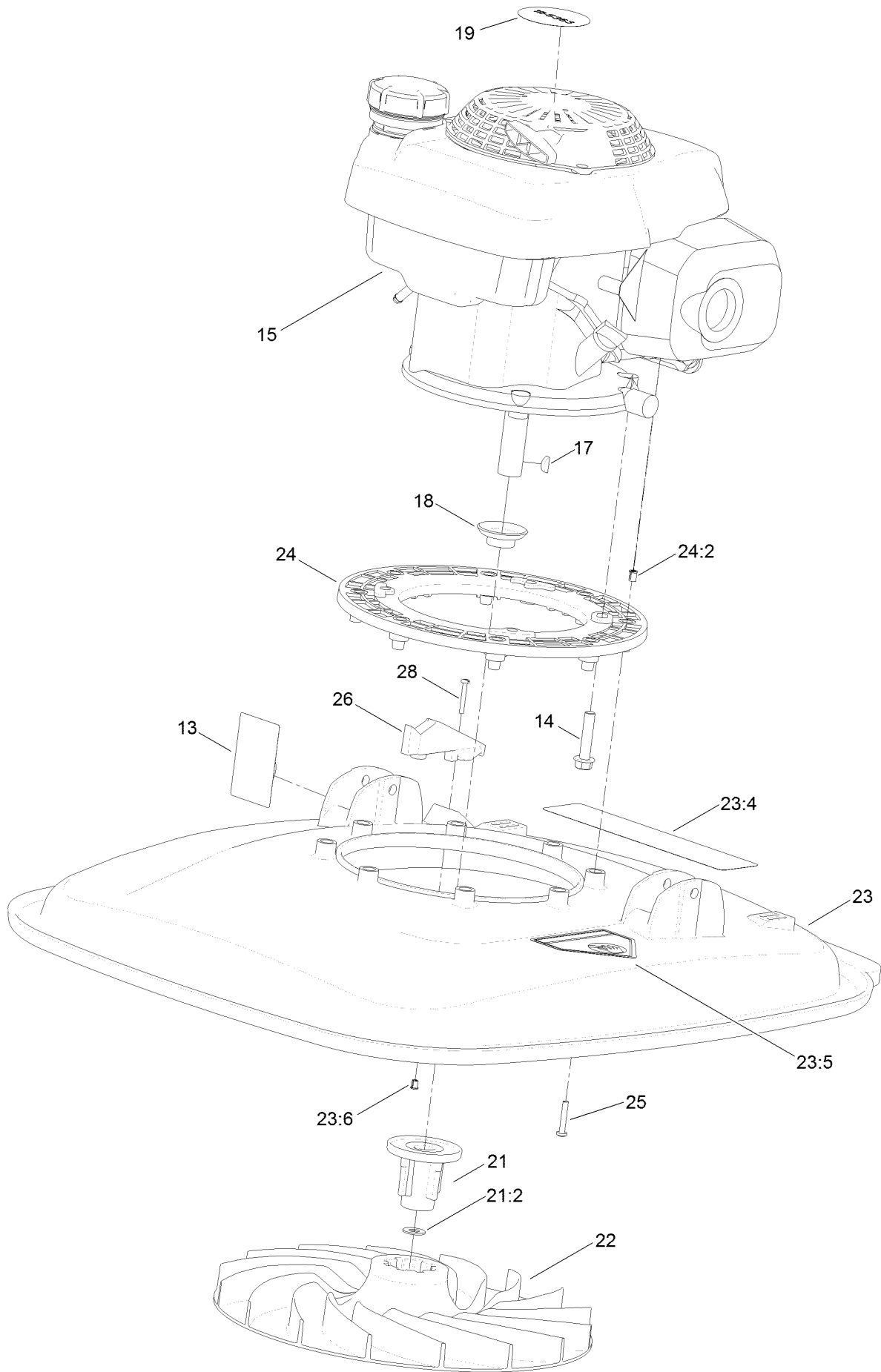

Engine and Deck Assembly (continued)

<i>Ref.</i>	<i>Part Number</i>	<i>Qty.</i>	<i>Description</i>	<i>Ref.</i>	<i>Part Number</i>	<i>Qty.</i>	<i>Description</i>
13	H295124	1	Decal	23	111-6004	1	Deck ASM
14	111-2157	4	Screw-Taptite	23:4	111-5393	1	Decal-Warning
15	111-7163	1	Engine-Honda	23:5	94-8072	1	Decal-Danger
17	1662	1	Key-Woodruff	23:6	H292280	2	Insert
18	H190118	1	Protector-Seal, Oil	24	H290003	1	Frame-Engine
19	111-7340	1	Decal-Engine, Gcv 160	24:2	H192266	8	Insert-Brass
21	H290011	1	Drive And Spacer ASM	25	H292004	8	Set-Screw
21:2	09479	1	Washer-Plain	26	H292269	1	Bracket
22	H192268	1	Impeller	28	H292279	2	Screw

Handle Assembly

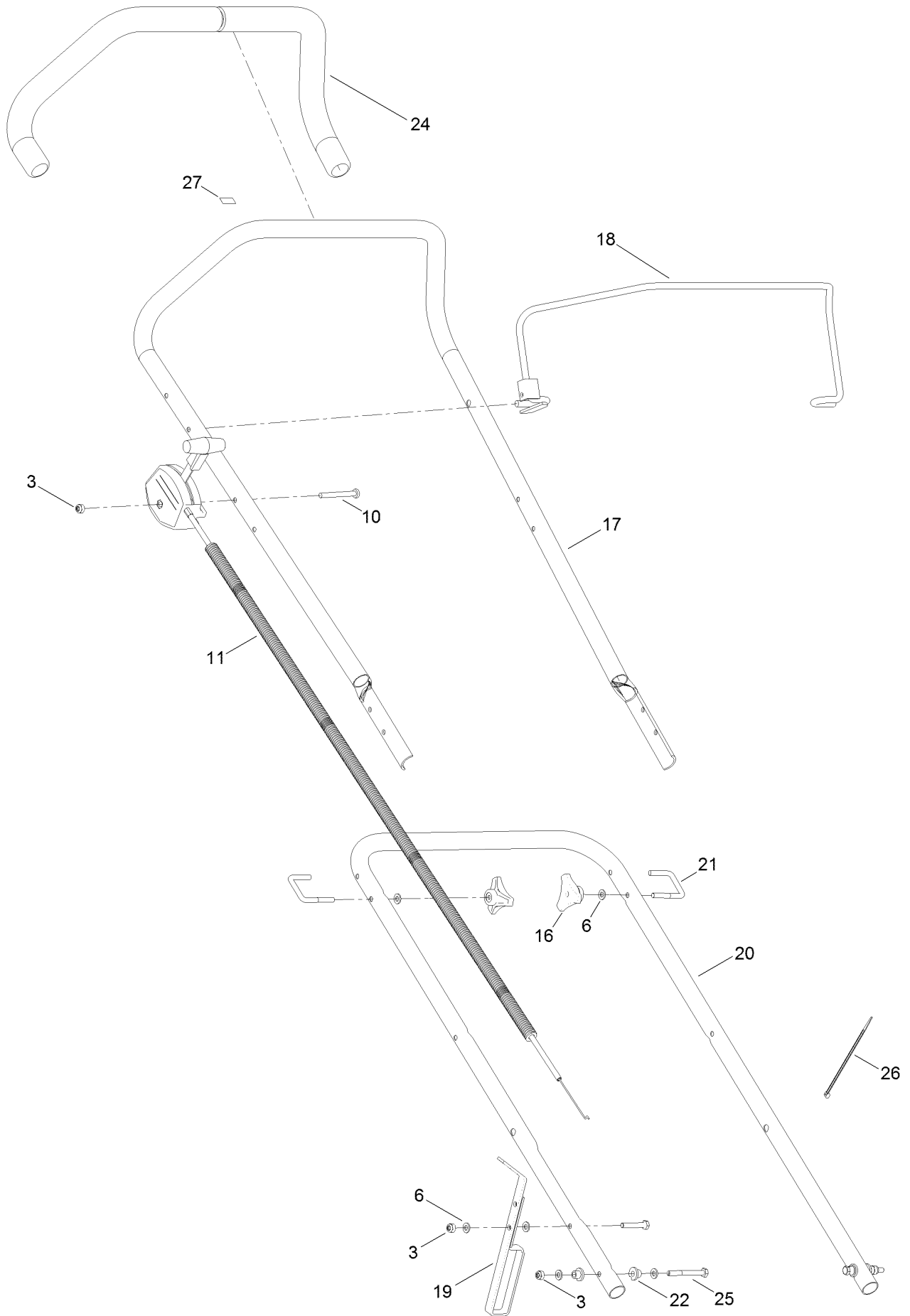

Handle Assembly (continued)

<i>Ref.</i>	<i>Part Number</i>	<i>Qty.</i>	<i>Description</i>	<i>Ref.</i>	<i>Part Number</i>	<i>Qty.</i>	<i>Description</i>
3	09438	4	Nut-Nyloc	20	111-7260-03	1	Handle-Lower
6	111-7679	8	Washer-Plain	21	H292026	2	Bolt-U
10	09780	1	Setscrew	22	H292058	4	Spacer-Handle
11	111-7261	1	Throttle Control ASM	24	H292276	2	Grip-Handle
16	H192204	2	Handwheel	25	H292309	2	Bolt-Hex
17	H290237	1	Handle-Upper	26	HY3966	2	Tie-Cable
18	H290239	1	Arm-Bail	27	H295159	1	Decal-Stop
19	H290286	1	Footstop				

Cutting Assembly

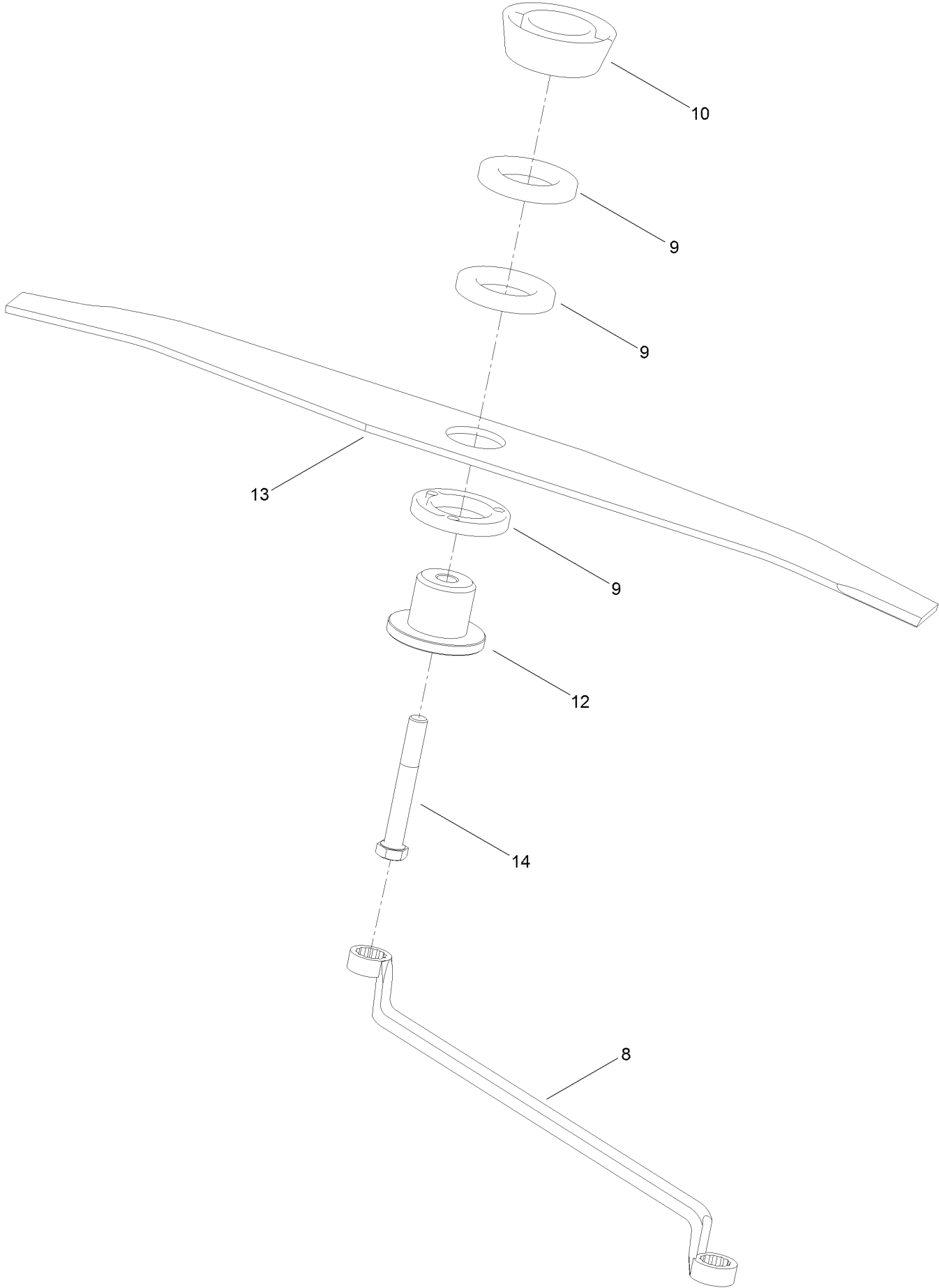

Cutting Assembly (continued)

<i>Ref.</i>	<i>Part Number</i>	<i>Qty.</i>	<i>Description</i>	<i>Ref.</i>	<i>Part Number</i>	<i>Qty.</i>	<i>Description</i>
8	H190210	1	Spanner	12	H192272	1	Retainer-Blade
9	H192025	3	Spacer-Blade, Aluminium	13	H192299	1	Blade-Mkii, 53 Cm
10	H192270	1	Spacer-Distance	14	H292018	1	Screw-Set

Cylinder Barrel Assembly

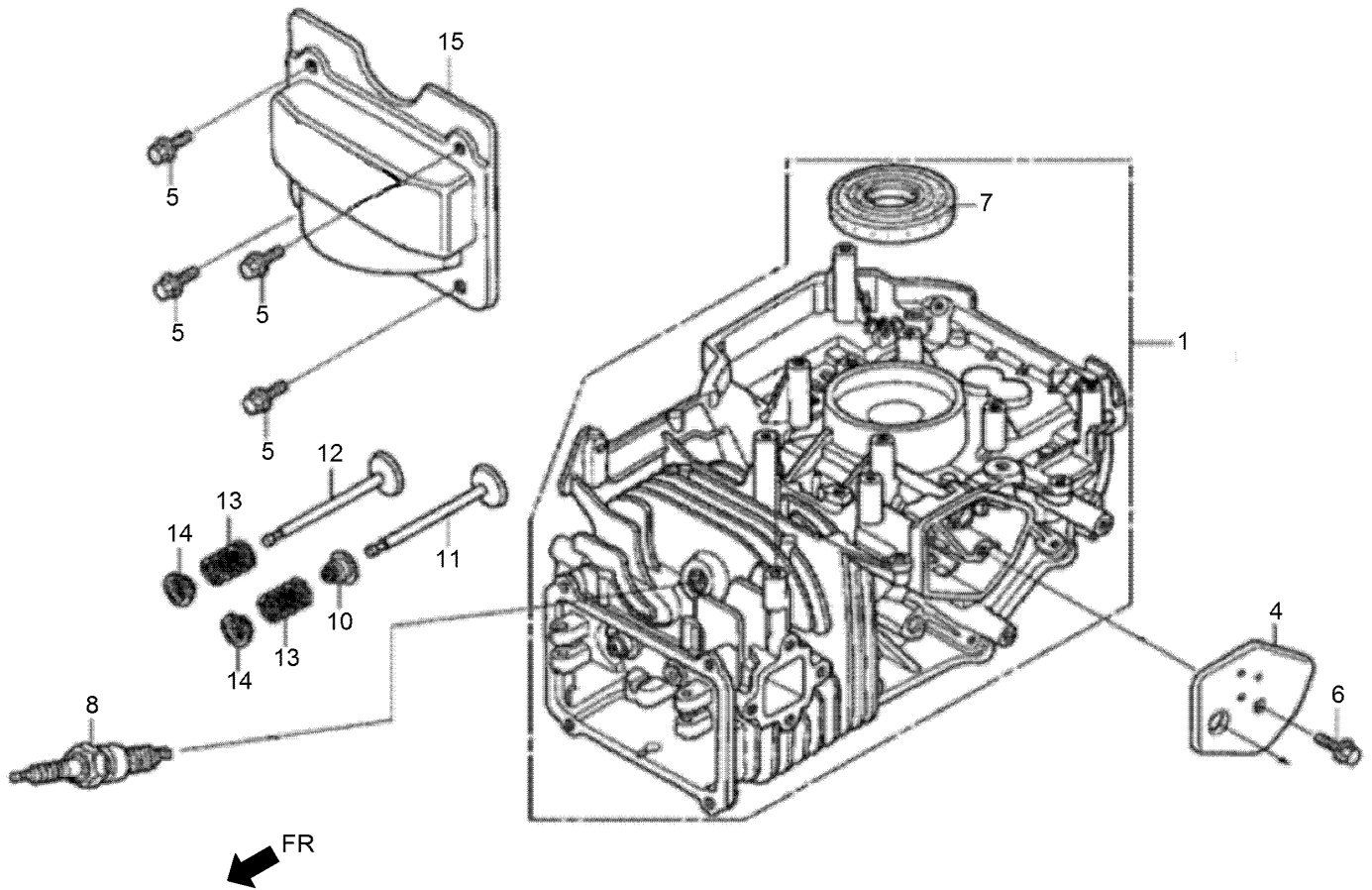

Cylinder Barrel Assembly (continued)

<i>Ref.</i>	<i>Part Number</i>	<i>Qty.</i>	<i>Description</i>	<i>Ref.</i>	<i>Part Number</i>	<i>Qty.</i>	<i>Description</i>
1	132-0115	1	Barrel ASM-Cylinder	11	132-0193	1	Valve-Intake
4	132-0131	1	Breather Cover ASM	11	132-0196	1	Valve-Intake
5	132-4880	4	Bolt-Flange-6X12	12	132-0199	1	Valve-Exhaust
6	132-0595	1	Bolt-Flange-6X14	12	132-0201	1	Valve-Exhaust
7	132-0655	1	Oil Seal-25.4X62X6	13	132-0207	2	Spring-Valve
8	131-8231	1	Plug-Spark [ngk]	14	132-0210	2	Retainer-Valve Spring
10	132-0121	1	Seal-Valve Stem	15	132-0128	1	Cover-Head

Oil Pan Assembly

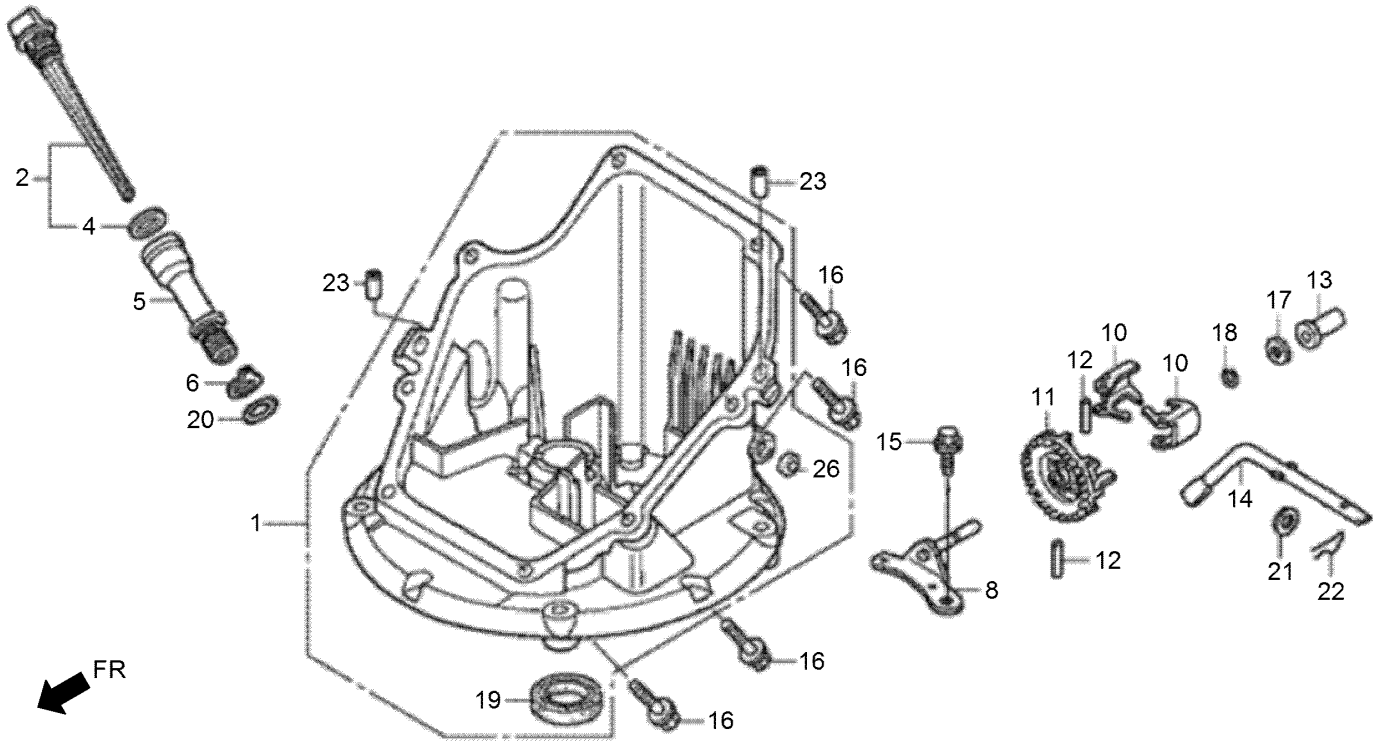

Oil Pan Assembly (continued)

<i>Ref.</i>	<i>Part Number</i>	<i>Qty.</i>	<i>Description</i>	<i>Ref.</i>	<i>Part Number</i>	<i>Qty.</i>	<i>Description</i>
1	132-0102	1	Pan ASM-Oil	15	132-0595	1	Bolt-Flange-6X14
2	132-0231	1	Gauge ASM-Oil Level	16	132-0620	8	Bolt-Flange-6X25
4	132-0226	1	Packing-Oil Filler Cap	17	132-0635	1	Washer-Thrust-6Mm
5	132-0227	1	Extension-Oil Filler	18	132-0642	1	Clip-Governor Holder
6	132-0229	1	Washer-Extension Lock	19	132-0660	1	Oil Seal-28X41.25X6
8	132-0295	1	Governor Holder Shaft ASM	20	132-0665	1	O-Ring-14.8X2.4
10	132-0299	2	Weight-Governor	21	132-0688	1	Washer-Plain-6Mm
11	132-0301	1	Holder-Governor Weight	22	132-0693	1	Pin-Lock-8Mm
12	132-0303	2	Pin-Governor Weight	23	132-0646	2	Dowel Pin-8X20
13	132-0304	1	Slider-Governor	26	132-0661	1	Oil Seal-6X11X4
14	132-0306	1	Shaft-Governor Arm				

Crankshaft Assembly

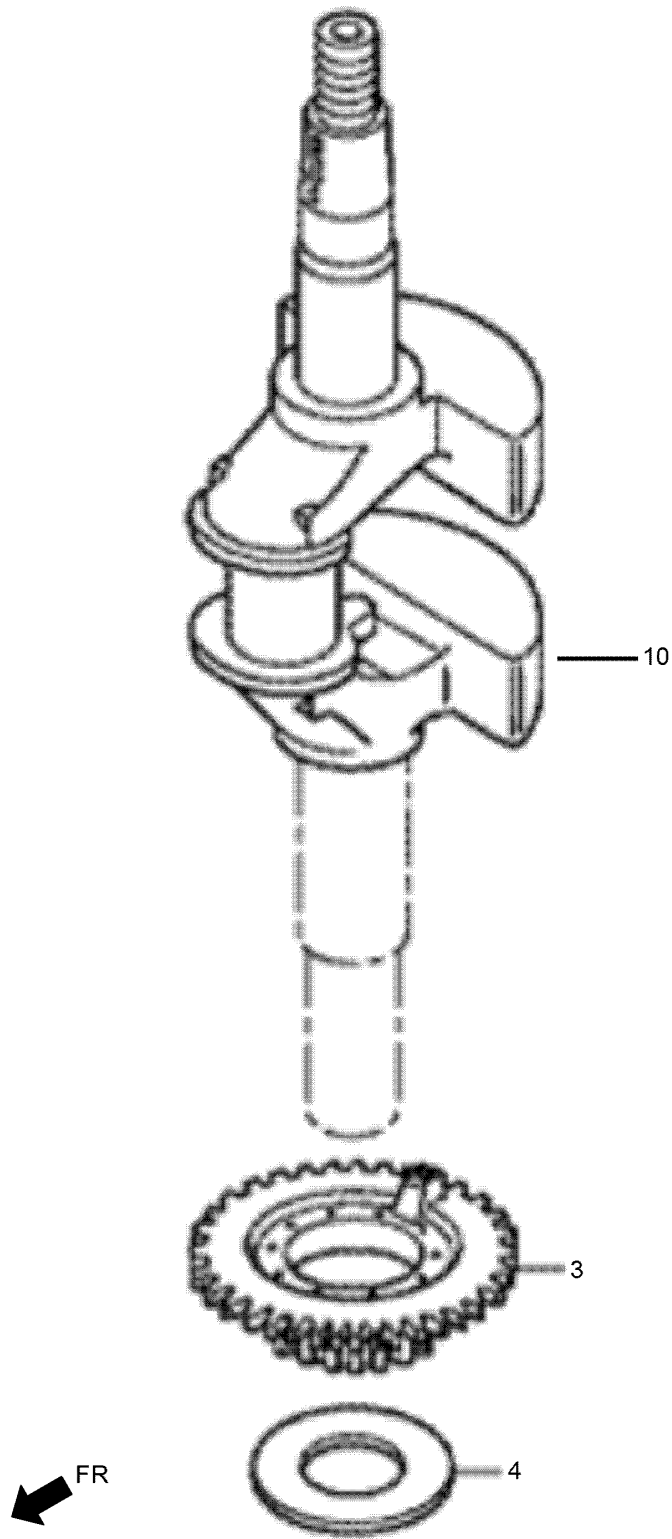

Crankshaft Assembly (continued)

<i>Ref.</i>	<i>Part Number</i>	<i>Qty.</i>	<i>Description</i>
3	132-0170	1	Pulley-Timing Belt Drive
4	132-0632	1	Washer-Thrust
10	132-0166	1	Crankshaft

Piston and Connecting Rod Assembly

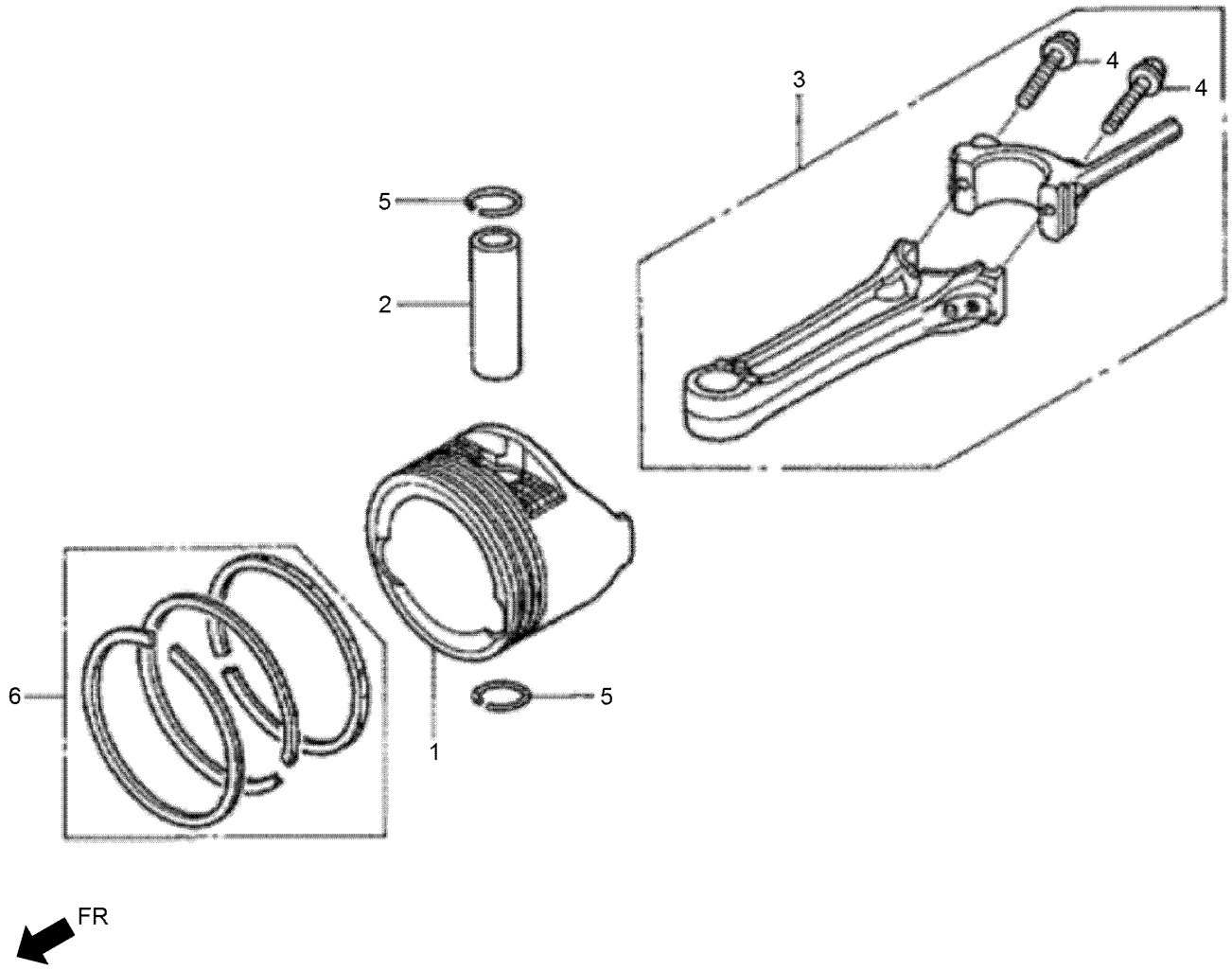

Piston and Connecting Rod Assembly (continued)

<i>Ref.</i>	<i>Part Number</i>	<i>Qty.</i>	<i>Description</i>	<i>Ref.</i>	<i>Part Number</i>	<i>Qty.</i>	<i>Description</i>
1	132-0145	1	Piston	4	132-0586	2	Bolt-Connecting Rod
2	132-0151	1	Pin-Piston	5	132-0636	2	Clip-Piston Pin-13Mm
3	132-0154	1	Rod ASM-Connecting	6	132-0136	1	Ring Set-Piston (STD)

Camshaft Pulley Assembly

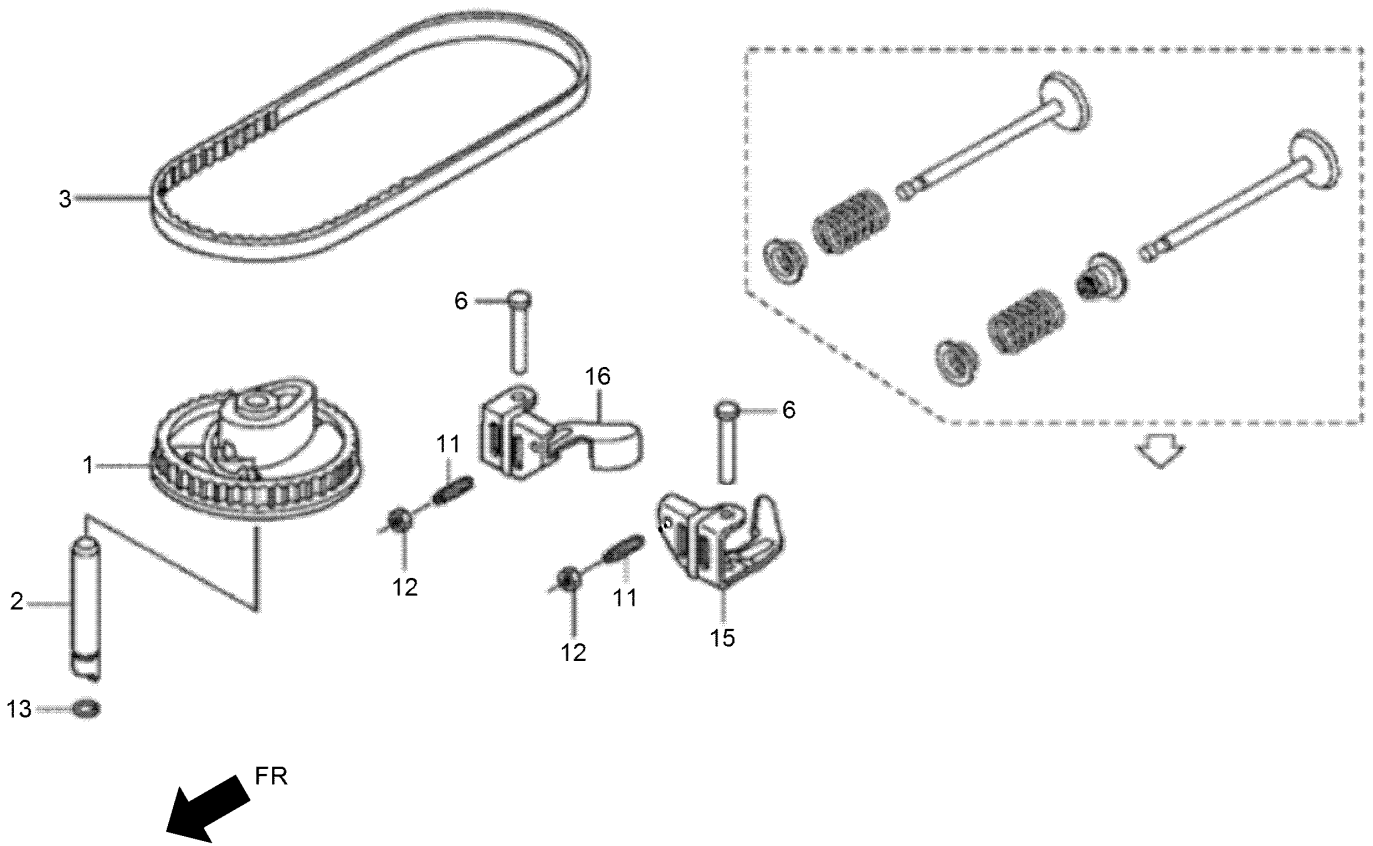

Camshaft Pulley Assembly (continued)

<i>Ref.</i>	<i>Part Number</i>	<i>Qty.</i>	<i>Description</i>	<i>Ref.</i>	<i>Part Number</i>	<i>Qty.</i>	<i>Description</i>
1	132-0174	1	Camshaft Pulley ASM	12	132-0627	2	Nut-Tappet Adjusting
2	132-0176	1	Shaft-Cam Pulley	13	132-0664	1	O-Ring-6.8X1.9
3	132-0178	1	Belt-Timing	15	132-0183	1	Arm-Intake Valve Rocker
6	132-0190	2	Shaft-Rocker Arm	16	132-0187	1	Arm-Exhaust Valve Rocker
11	132-0589	2	Screw-Tappet Adjusting				

Recoil Starter Assembly

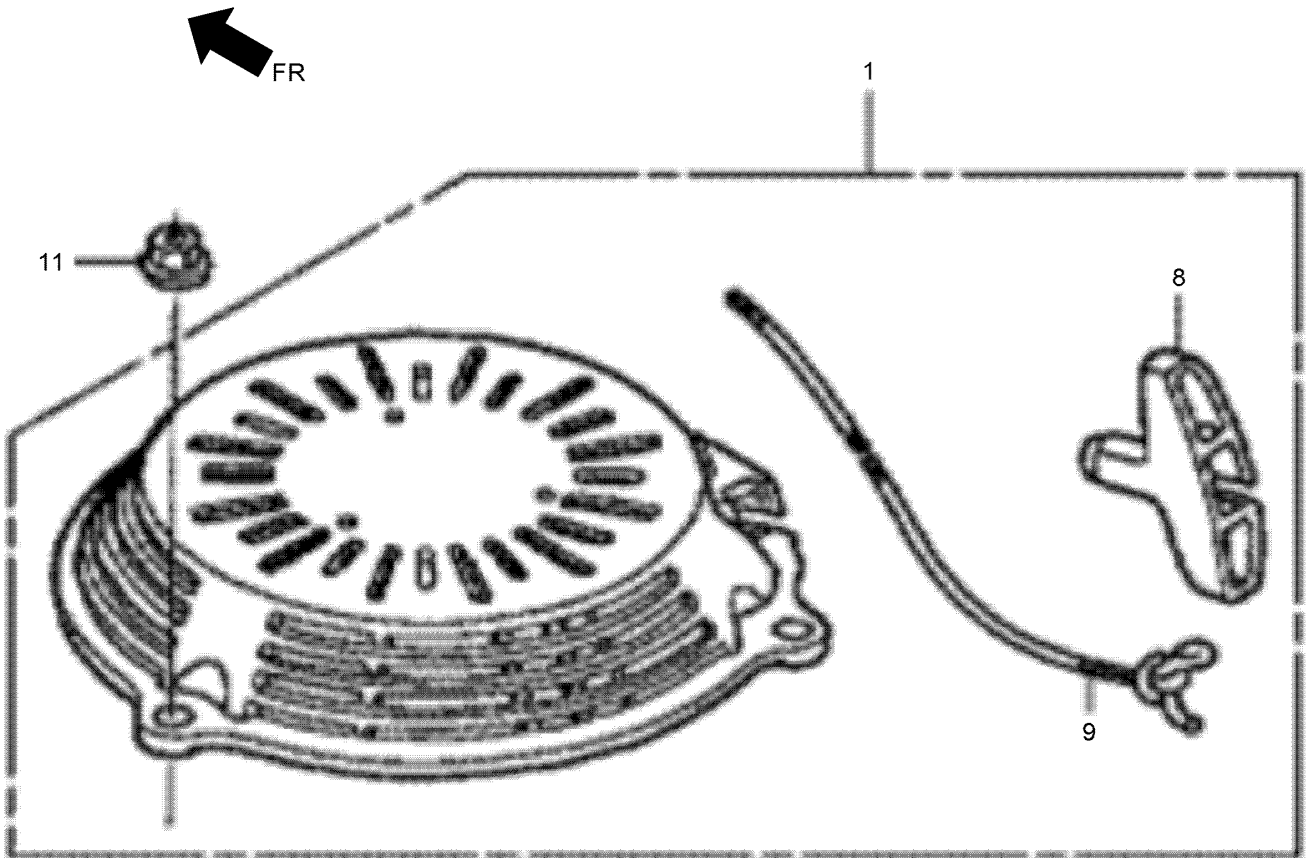

Recoil Starter Assembly (continued)

<i>Ref.</i>	<i>Part Number</i>	<i>Qty.</i>	<i>Description</i>	<i>Ref.</i>	<i>Part Number</i>	<i>Qty.</i>	<i>Description</i>
1	132-0479	1	Starter ASM-Recoil	9	132-0508	1	Rope-Recoil Starter
8	132-0505	1	Grip-Starter	11	132-0626	3	Nut-Flange-6Mm

Fuel Tank and Fuel Pump Assembly

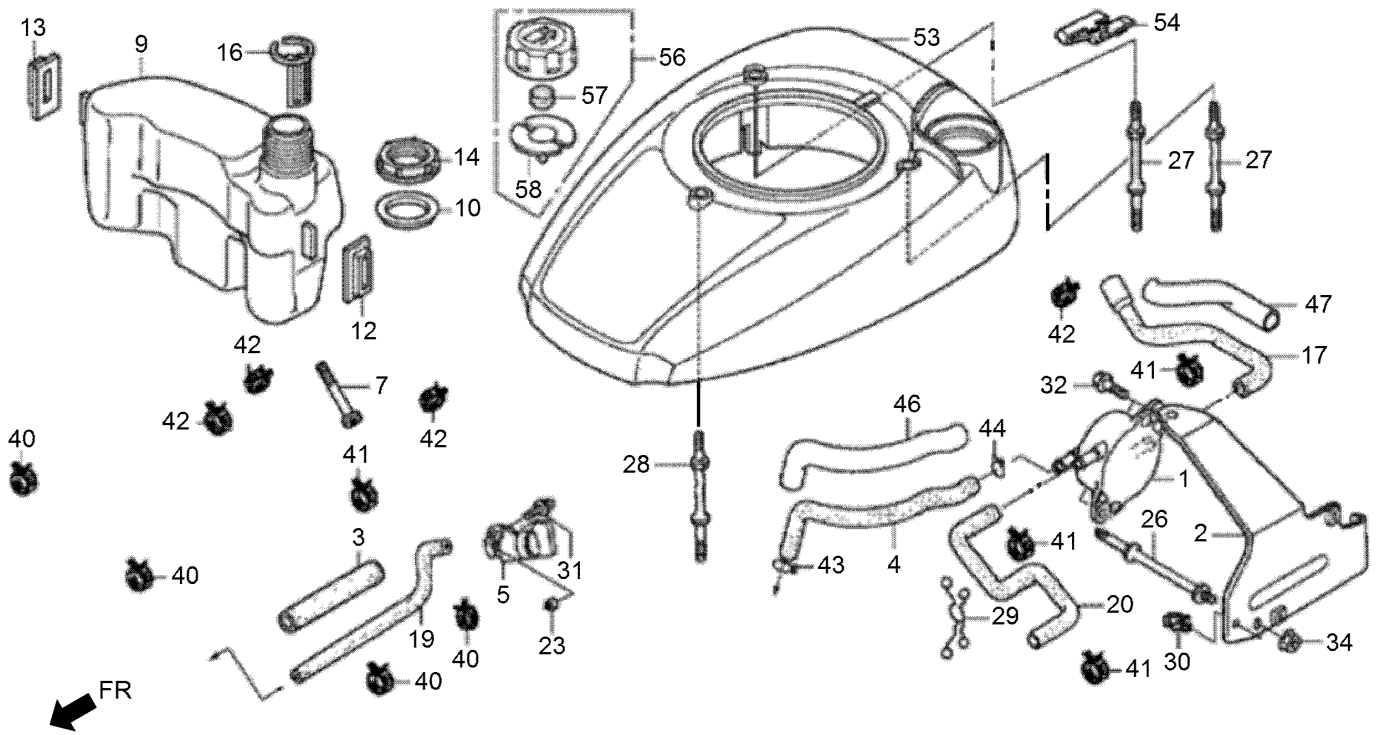

Fuel Tank and Fuel Pump Assembly (continued)

<i>Ref.</i>	<i>Part Number</i>	<i>Qty.</i>	<i>Description</i>	<i>Ref.</i>	<i>Part Number</i>	<i>Qty.</i>	<i>Description</i>
1	132-0346	1	Pump ASM-Fuel	28	132-0611	1	Bolt-Stud
2	132-0347	1	Stay-Fuel Pump	29	132-0639	1	Clip-Purse Lock
3	132-0349	1	Rubber-Supporter	30	132-0644	1	Clip-Wire Harness
4	132-0352	1	Tube-Diaphragm	31	132-0681	1	Screw-Washer-5X10
5	132-0355	1	Cock ASM-Fuel	32	132-0683	2	Screw-Washer-5X14
7	132-0356	1	Strainer-Fuel	34	132-4881	1	Nut-Flange-6Mm
9	132-0401	1	Tank-Fuel	40	131-8211	2	Clamp-Tube
10	132-0402	1	Seal-Fuel Filler Neck	41	131-8212	3	Clamp-Tube
12	132-0406	1	Rubber A-Tank Mounting	42	131-8213	1	Clamp-Tube
13	132-0408	1	Rubber B-Tank Mounting	43	131-8214	1	Clip-Tube
14	132-0409	1	Nut-Tank Mounting	44	131-8215	1	Clip-Tube
16	132-0432	1	Gauge-Fuel Level	46	131-8217	1	Tube-Vinyl-9X11X210
17	132-0436	1	Tube-Fuel Tank	47	131-8219	1	Tube-Vinyl-13X15X90
19	132-0438	1	Tube-Fuel	53	132-0470	1	Cover-Fan (Nh1)
20	132-0444	1	Tube B-Fuel	54	132-0404	1	Clip-Tank Mounting (Nh1)
23	132-0670	1	Collar-Fuel Cock	56	132-0411	1	Cap ASM-Fuel Tank
26	132-0607	1	Bolt-Stud	57	132-0420	1	Sponge-Fuel Cap Breather
27	132-0611	2	Bolt-Stud	58	132-0423	1	Packing-Fuel Cap

Carburetor Assembly

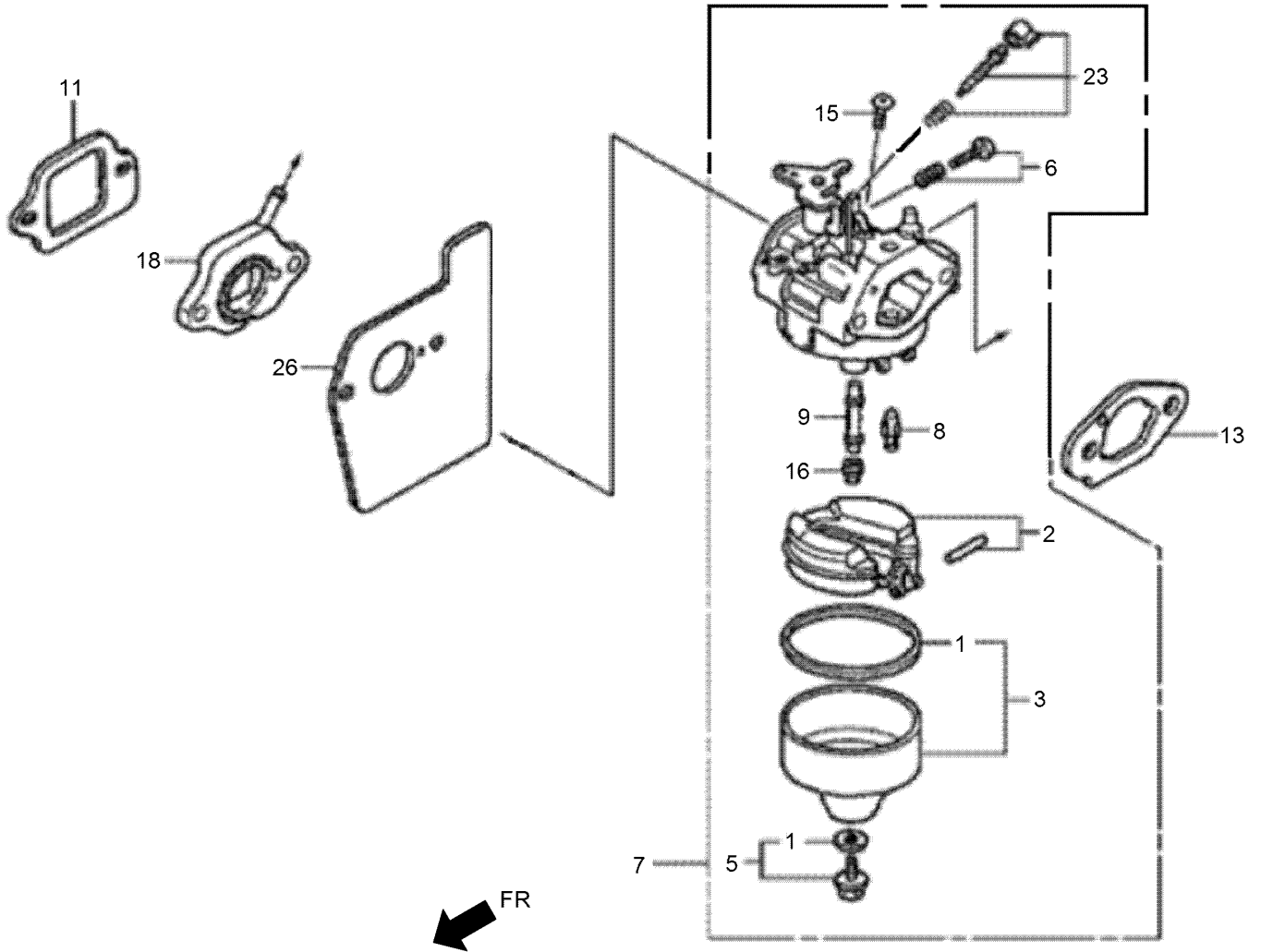

Carburetor Assembly (continued)

<i>Ref.</i>	<i>Part Number</i>	<i>Qty.</i>	<i>Description</i>	<i>Ref.</i>	<i>Part Number</i>	<i>Qty.</i>	<i>Description</i>
1	132-0238	1	Packing Set	11	132-0282	1	Packing-Insulator
2	132-0244	1	Float Set	13	132-0289	1	Packing-Carburetor
3	132-0246	1	Chamber Set-Float	15	132-0677	1	Screw-Pan-5X6
5	132-0254	1	Screw Set	16	131-8234	1	Jet-Main No. 62
6	132-0256	1	Screw Set	16	131-8235	1	Jet-Main No. 65
7	132-0267	1	Carburetor ASM (Bb65V A)	18	132-0279	1	Insulator-Carburetor
8	132-0270	1	Valve-Float	23	132-0249	1	Screw Set
9	132-0271	1	Nozzle-Main (Bb65V A)	26	132-0476	1	Guide-Air

Air Cleaner Assembly

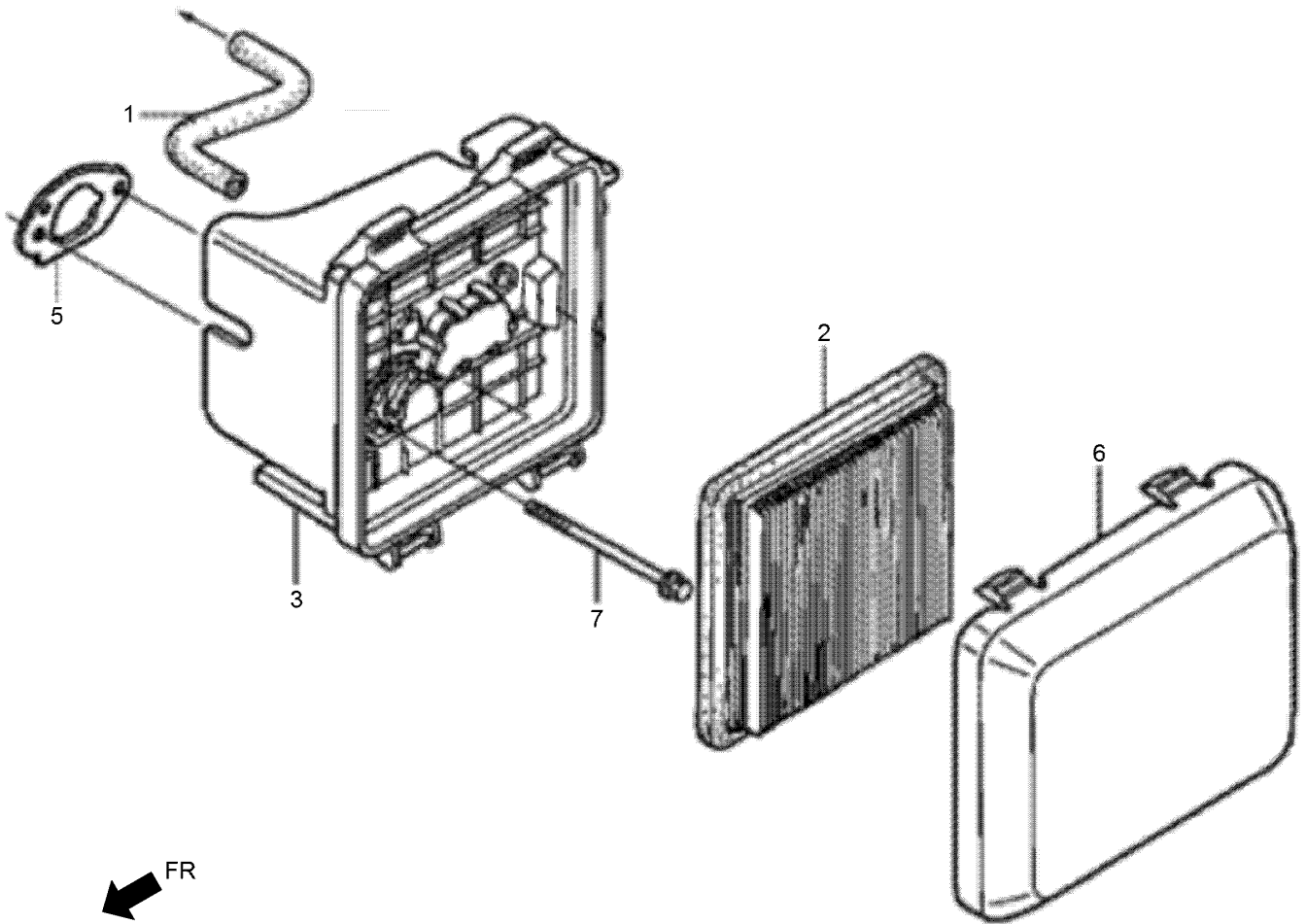

Air Cleaner Assembly (continued)

<i>Ref.</i>	<i>Part Number</i>	<i>Qty.</i>	<i>Description</i>	<i>Ref.</i>	<i>Part Number</i>	<i>Qty.</i>	<i>Description</i>
1	132-0235	1	Tube-Breather	5	132-0380	1	Packing-Air Cleaner
2	132-0369	1	Element-Air Cleaner	6	132-0386	1	Cover-Air Cleaner
3	132-0373	1	Case ASM-Air Cleaner	7	132-0578	2	Bolt-Special-6Mm

Muffler Assembly

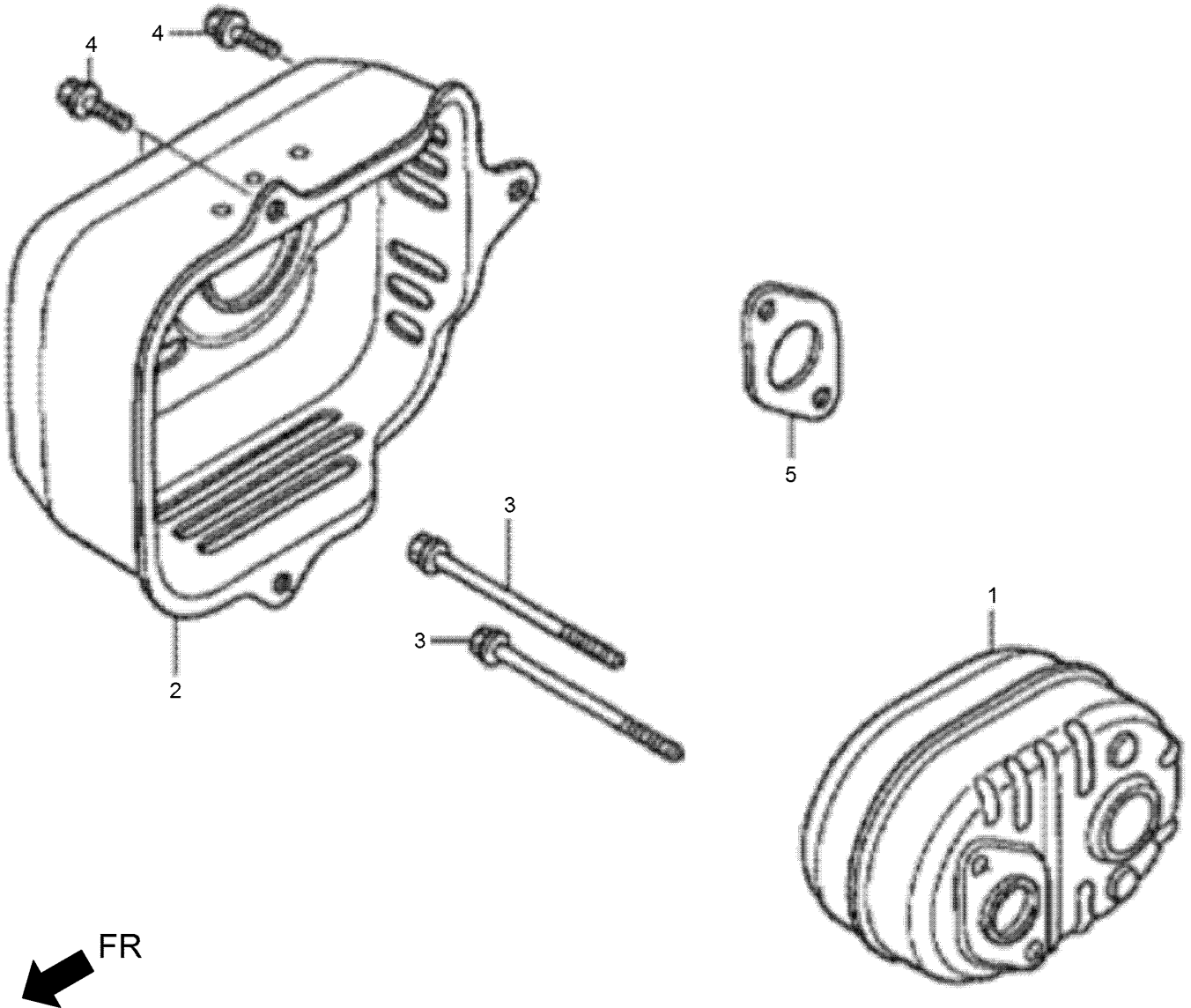

Muffler Assembly (continued)

<i>Ref.</i>	<i>Part Number</i>	<i>Qty.</i>	<i>Description</i>	<i>Ref.</i>	<i>Part Number</i>	<i>Qty.</i>	<i>Description</i>
1	132-0449	1	Muffler ASM	4	132-4880	3	Bolt-Flange-6X12
2	132-0452	1	Muffler Protector ASM	5	132-0458	1	Gasket-Muffler
3	132-0584	2	Bolt-Flange-6X79				

Flywheel and Ignition Coil Assembly

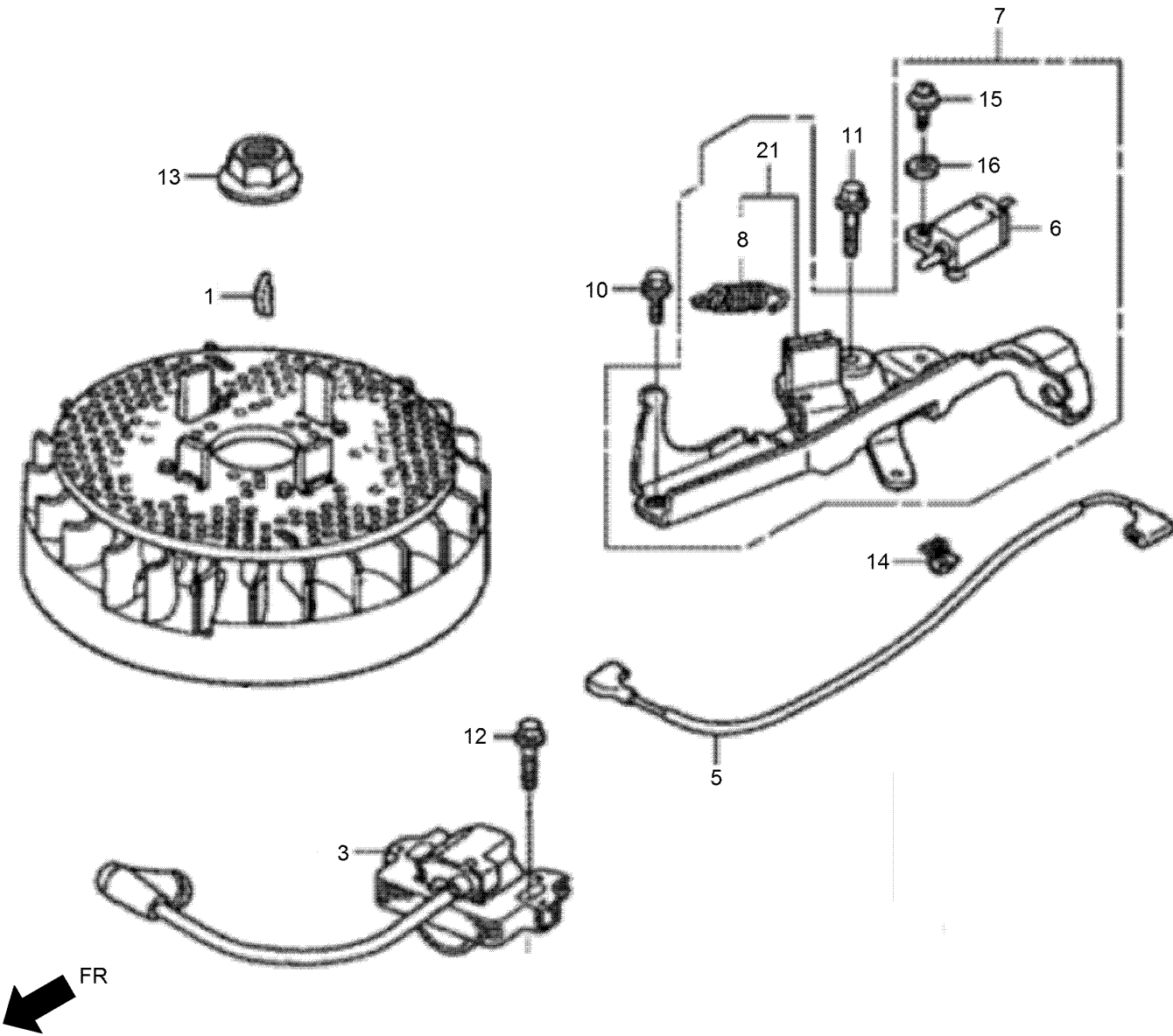

Flywheel and Ignition Coil Assembly (continued)

<i>Ref.</i>	<i>Part Number</i>	<i>Qty.</i>	<i>Description</i>	<i>Ref.</i>	<i>Part Number</i>	<i>Qty.</i>	<i>Description</i>
1	132-0168	1	Key-Special Woodruff-25X18	11	132-0603	1	Bolt-Flange-6X23
3	132-0512	1	Coil ASM-Ignition	12	132-0603	1	Bolt-Flange-6X23
5	132-0524	1	Cord-Stop Switch	13	132-0625	1	Nut-Special-14Mm
6	132-0531	1	Switch ASM-Engine Stop	14	132-0645	1	Clip A-Cable
7	132-0534	1	Brake ASM	15	132-0682	1	Screw-Washer-4X12
8	132-0538	1	Spring-Brake Lever	16	132-0689	1	Washer-Plain-4Mm
10	132-0595	1	Bolt-Flange-6X14	21	132-0537	1	Brake Sub ASM

Control Assembly

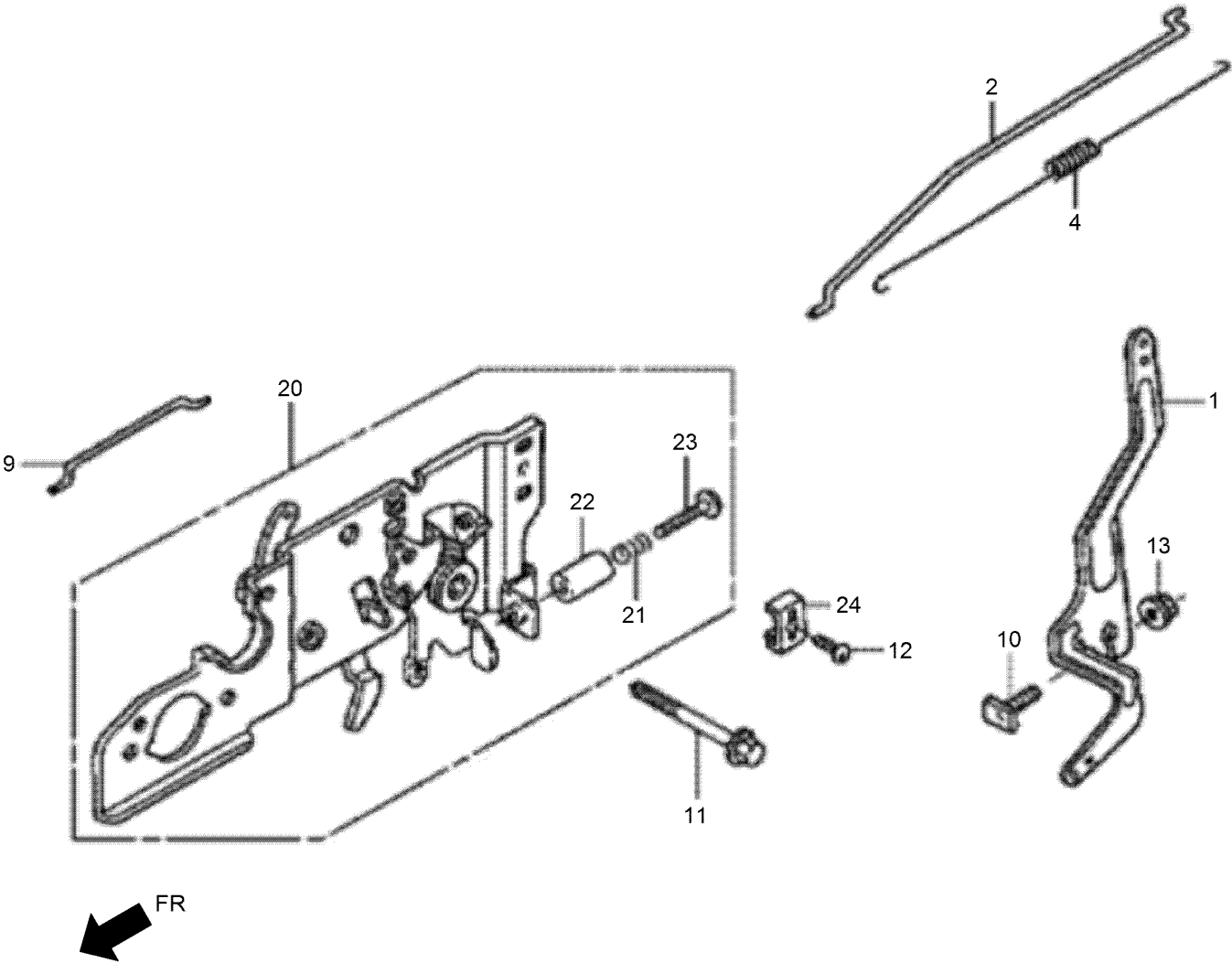

Control Assembly (continued)

<i>Ref.</i>	<i>Part Number</i>	<i>Qty.</i>	<i>Description</i>	<i>Ref.</i>	<i>Part Number</i>	<i>Qty.</i>	<i>Description</i>
1	132-0312	1	Arm-Governor	13	132-4881	1	Nut-Flange-6Mm
2	132-0315	1	Rod-Governor	20	132-0333	1	Control Base ASM
4	132-0325	1	Spring-Throttle Return	21	132-0340	1	Spring-Control Adjusting
9	132-0345	1	Rod-Choke	22	132-0342	1	Collar-Stopper
10	132-0598	1	Bolt-Governor Arm	23	132-0601	1	Screw-Recessed-5X28
11	132-0594	1	Bolt-Flange-6X50	24	132-0344	1	Holder-Cable
12	132-0678	1	Screw-Pan-5X16				

Label Assembly

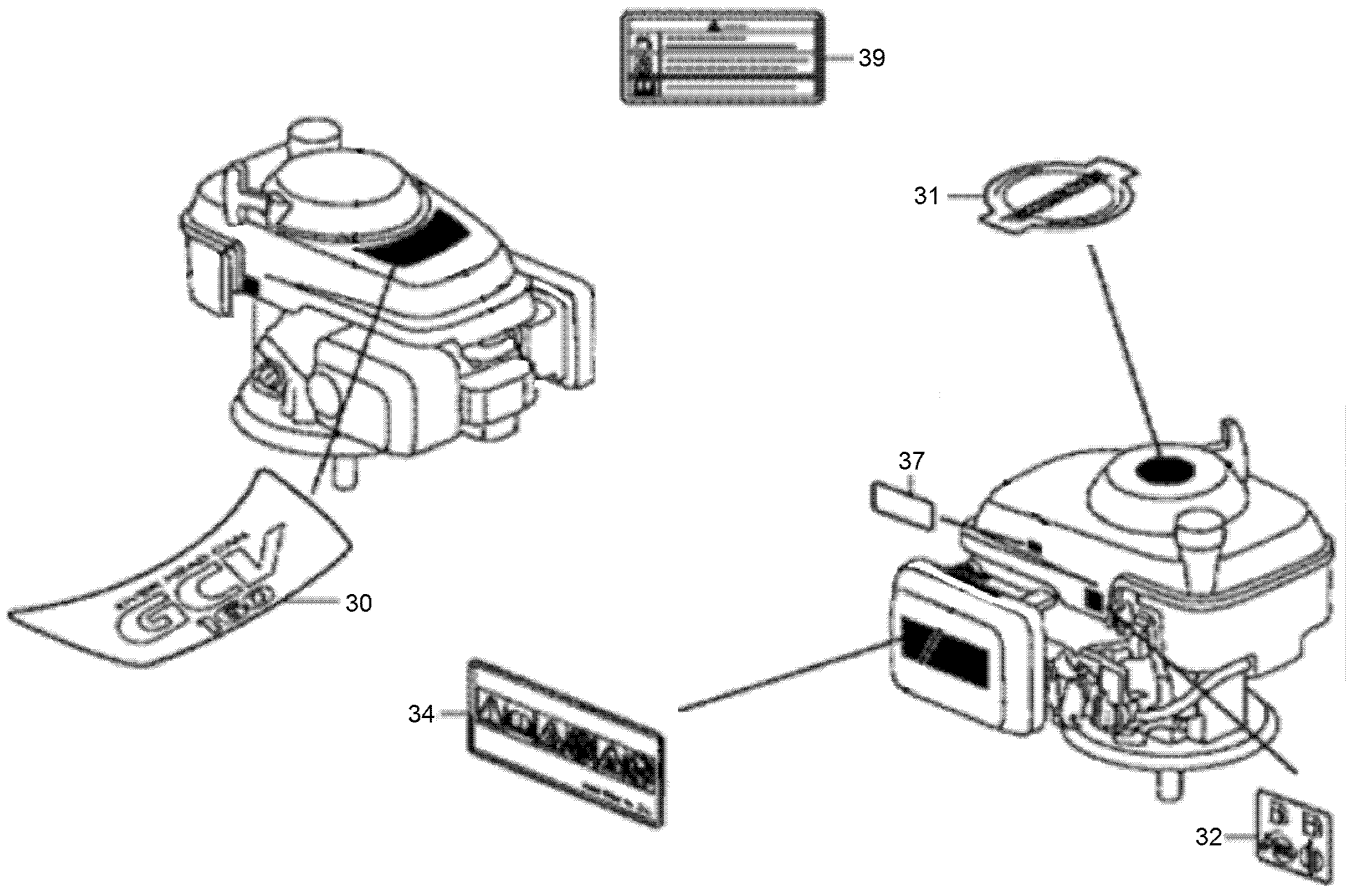

Label Assembly (continued)

<i>Ref.</i>	<i>Part Number</i>	<i>Qty.</i>	<i>Description</i>	<i>Ref.</i>	<i>Part Number</i>	<i>Qty.</i>	<i>Description</i>
30	132-0543	1	Mark-Emblem	37	132-0546	1	Label-Warning
31	132-0548	1	Mark-Recoil Cover	39	132-0554	1	Mark-Operator Caution (China)
32	132-0565	1	Mark-Fuel Cock Caution				
34	132-4879	1	Mark-Operator Caution				

Attachments and Accessories

For 02606 HoverPro 550 Machine

Product Name	Model/Part
Transport Wheel Kit	02622
Handlebar Extension Kit	02623

Notes:

Notes:

Notes:



Count on it.