



Wheel Horse®

270HE

Lawn & Garden Tractor

Model No. 72110 – 6900001 & Up

Operator's Manual

IMPORTANT: Read this manual carefully. It contains information about your safety and the safety of others. Also become familiar with the controls and their proper use before you operate the product.

Introduction

Thank you for purchasing a Toro product.

All of us at Toro want you to be completely satisfied with your new product, so feel free to contact your local Authorized Service Dealer for help with service, genuine replacement parts, or other information you may require.

Whenever you contact your Authorized Service Dealer or the factory, always know the model and serial numbers of your product. These numbers will help the Service Dealer or Service Representative provide exact information about your specific product. You will find the model and serial number plate located in a unique place on the product as shown below.

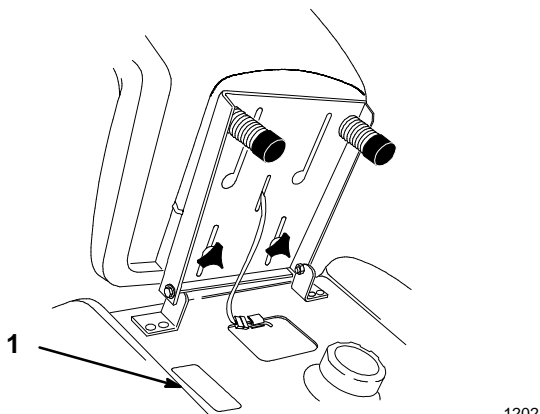

1. Model and Serial Number Plate (under the seat)

For your convenience, write the product model and serial numbers in the space below.

Model No: _____
Serial No. _____

Read this manual carefully to learn how to operate and maintain your product correctly. Reading this manual will help you and others avoid personal injury and damage to the product. Although we design, produce and market safe, state-of-the-art products, you are responsible for using the product properly and safely. You are also responsible for training persons, who you allow to use the product, about safe operation.

The warning system in this manual identifies potential hazards and has special safety messages that help you and others avoid personal injury, even death. **DANGER**, **WARNING** and **CAUTION** are signal words used to identify the level of hazard. However, regardless of the hazard, be extremely careful.

DANGER signals an extreme hazard that will cause serious injury or death if the recommended precautions are not followed.

WARNING signals a hazard that may cause serious injury or death if the recommended precautions are not followed.

CAUTION signals a hazard that may cause minor or moderate injury if the recommended precautions are not followed.

Two other words are also used to highlight information. “Important” calls attention to special mechanical information and “Note” emphasizes general information worthy of special attention.

The left and right side of the machine is determined by sitting on the seat in the normal operator’s position.

Contents

	Page		Page
Safety	2	Positioning the Seat	16
Safe Operation Practices for Ride-on (riding)		Headlights	16
Rotary Lawnmower Machines	2	Positioning the	
Sound Pressure Level	4	Tilt Steering Wheel	16
Sound Power Level	4	Using the Cruise Control	17
Vibration Level	4	Pushing the Machine by Hand	17
Slope Chart	5	Maintenance	18
Symbols Glossary	6	Service Interval Chart	18
Gasoline and Oil	9	Air Cleaner	19
Recommended Gasoline	9	Engine Oil	21
Stabilizer/Conditioner	9	Spark Plug	23
Filling the Fuel Tank	9	Greasing and Lubrication	24
Check Engine Oil Level	9	Tire Pressure	24
Operation	10	Brake	25
Think Safety First	10	Fuel Tank	26
Controls	10	Fuel Filter	27
Parking Brake	10	Power Lift	27
Starting and Stopping the Engine	11	Front Wheel Toe-In	28
Operating the Power Take Off (PTO)	12	Transaxle Fluid	29
The Safety Interlock System	12	Fuse	29
Indicator Control Module	13	Headlights	30
Driving Forward or Backward	14	Battery	31
Stopping the Machine	14	Wiring Diagram	34
Attachment Power Lift	15	Cleaning and Storage	35
Adjusting Dial-A-Height	15	Troubleshooting	36

Safety

Safe Operation Practices for Ride-on (riding) Rotary Lawnmower Machines

Training

1. Read the instructions carefully. Be familiar with the controls and the proper use of the equipment.
2. Never allow children or people unfamiliar with these instructions to use the lawnmower. Local regulations may restrict the age of the operator.
3. Never mow while people, especially children, or pets are nearby.
4. Keep in mind that the operator or user is responsible for accidents or hazards occurring to other people or their property.
5. Do not carry passengers.
6. All drivers should seek and obtain professional and practical instruction. Such instruction should emphasize:
 - the need for care and concentration when working with ride-on machines;
 - control of a ride-on machine sliding on a slope will not be regained by the application of the brake. The main reasons for loss of control are:
 - insufficient wheel grip;
 - being driven too fast;
 - inadequate braking;
 - the type of machine is unsuitable for its task;
 - lack of awareness of the effects of ground conditions, especially slopes;
 - incorrect hitching and load distribution.

Preparation

1. While mowing, always wear substantial footwear and long trousers. Do not operate the equipment when barefoot or wearing open sandals.
2. Thoroughly inspect the area where the equipment is to be used and remove all objects which may be thrown by the machine.
3. **WARNING** – Petrol is highly flammable.
 - Store fuel in containers specifically designed for this purpose.
 - Refuel outdoors only and do not smoke while refuelling.
 - Add fuel before starting the engine. Never remove the cap of the fuel tank or add petrol while the engine is running or when the engine is hot.
 - If petrol is spilled, do not attempt to start the engine but move the machine away from the area of spillage and avoid creating any source of ignition until petrol vapors have dissipated.
 - Replace all fuel tanks and container caps securely.
4. Replace faulty silencers.
5. Before using, always visually inspect to see that the blades, blade bolts and cutter assembly are not worn or damaged. Replace worn or damaged blades and bolts in sets to preserve balance.
6. On multi-bladed machines, take care as rotating one blade can cause other blades to rotate.

Operation

1. Do not operate the engine in a confined space where dangerous carbon monoxide fumes can collect.
2. Mow only in daylight or in good artificial light.
3. Before attempting to start the engine, disengage all blade attachment clutches and shift into neutral.
4. Do not use on slopes of more than:
 - Never mow side hills over 5°
 - Never mow uphill over 10°
 - Never mow downhill over 15°

Note: Slope angle is calculated as in 5.4.2.3.2.
5. Remember there is no such thing as a “safe” slope. Travel on grass slopes requires particular care. To guard against overturning:
 - do not stop or start suddenly when going up or downhill;
 - engage clutch slowly, always keep machine in gear, especially when travelling downhill;
 - machine speeds should be kept low on slopes and during tight turns;
 - stay alert for bumps and hollows and other hidden hazards;
 - never mow across the face of the slope, unless the lawnmower is designed for this purpose.
6. Use care when pulling loads or using heavy equipment.
 - Use only approved drawbar hitch points.
 - Limit loads to those you can safely control.
 - Do not turn sharply. Use care when reversing.
 - Use counterweight(s) or wheel weights when suggested in the instruction handbook.
7. Watch out for traffic when crossing or near roadways.
8. Stop the blades rotating before crossing surfaces other than grass.
9. When using any attachments, never direct discharge of material toward bystanders nor allow anyone near the machine while in operation.
10. Never operate the lawnmower with defective guards, shields or without safety protective devices in place.
11. Do not change the engine governor settings or overspeed the engine. Operating the engine at excessive speeds may increase the hazard of personal injury.
12. Before leaving the operator’s position:
 - disengage the power take-off and lower the attachments;
 - change into neutral and set the parking brake;
 - stop the engine and remove the key.
13. Disengage drive to attachments, stop the engine, and disconnect the spark plug wire(s) or remove the ignition key
 - before cleaning blockages or unclogging chute;
 - before checking, cleaning or working on the lawnmower;
 - after striking a foreign object. Inspect the lawnmower for damage and make repairs before restarting and operating the equipment;
 - if the machine starts to vibrate abnormally (check immediately).
14. Disengage drive to attachments when transporting or not in use.

15. Stop the engine and disengage drive to attachment
 - before refuelling;
 - before removing the grass catcher;
 - before making height adjustment unless adjustment can be made from the operator's position.
16. Reduce the throttle setting during engine run-out and, if the engine is provided with a shut-off valve, turn the fuel off at the conclusion of mowing.

Maintenance and storage

1. Keep all nuts, bolts and screws tight to be sure the equipment is in safe working condition.
2. Never store the equipment with petrol in the tank inside a building where fumes may reach an open flame or spark.
3. Allow the engine to cool before storing in any enclosure.
4. To reduce the fire hazard, keep the engine, silencer, battery compartment and petrol storage area free of grass, leaves, or excessive grease.
5. Check the grass catcher frequently for wear or deterioration.
6. Replace worn or damaged parts for safety.
7. If the fuel tank has to be drained, this should be done outdoors.
8. On multi-bladed machines, take care as rotating one blade can cause other blades to rotate.
9. When machine is to be parked, stored or left unattended, lower the cutting means unless a positive mechanical lock is used.

Sound Pressure Level

This unit has an equivalent continuous A-weighted sound pressure at the operator ear of: 100 dB(A), based on measurements of identical machines per ANSI B71.5-1984 procedures.

Sound Power Level

This unit has a sound power level of: 100 dB(A) / 1 pW, based on measurements of identical machines per procedures outlined in Directive 79/113/EEC and amendments. The test surface consisted of a surface of coconut mat surrounded by 2" grass.

Vibration Level







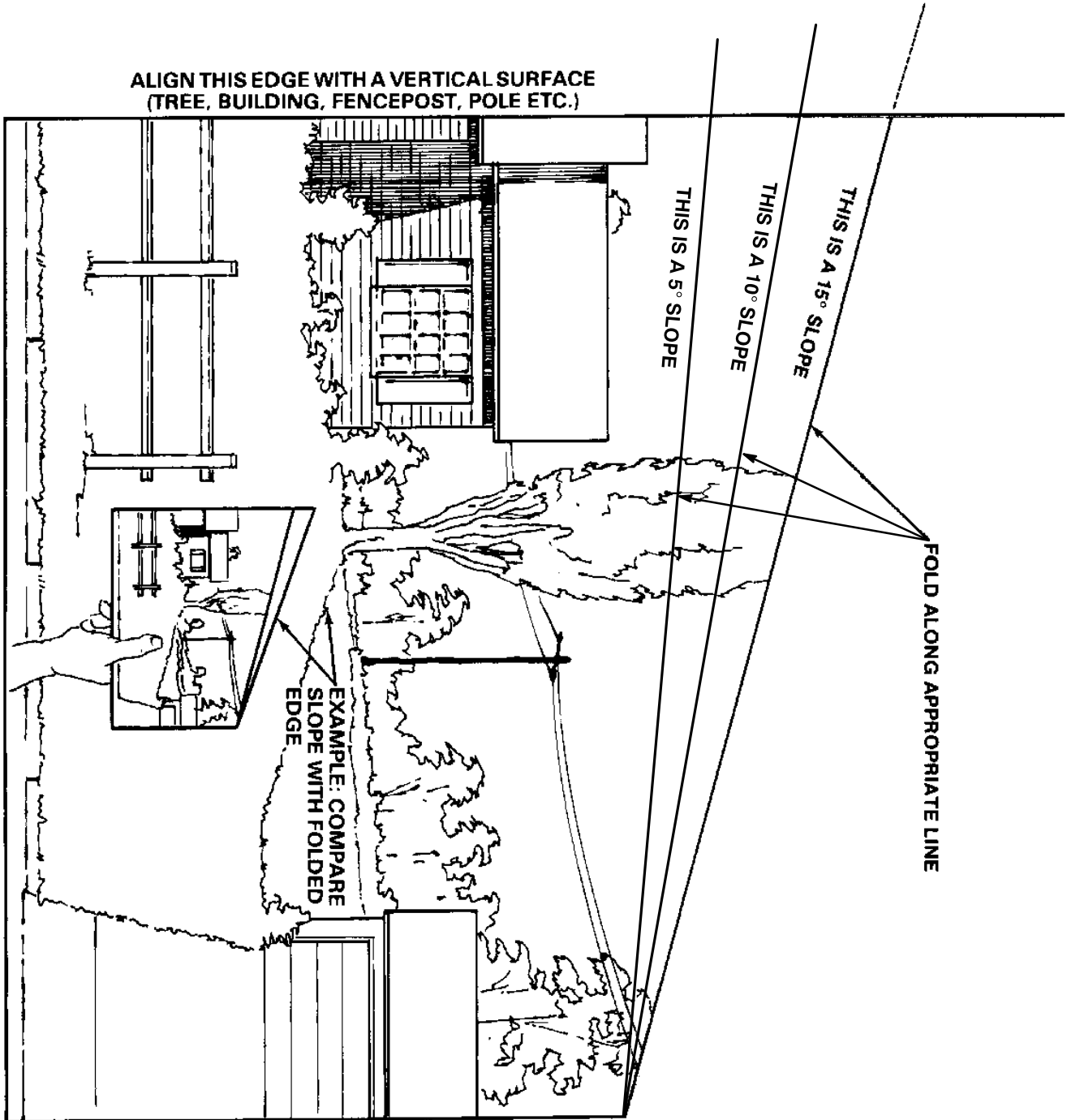



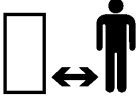



This unit has a maximum hand-arm vibration level of 5.02 m/s² and whole body vibration level of 0.222 m/s², based on measurements of identical machines per ISO 5349.

Slope Chart

Read all safety instructions on pages 2-8.



Symbols Glossary

Safety alert symbol		Dismemberment—Mower in rearward motion	
Safety alert symbol		Stay a safe distance from the machine	
Read operator's manual		Stay a safe distance from the mower	
Consult Technical Manual for proper service procedures		Keep children a safe distance from machine	
Thrown or flying objects—Whole body exposure		Machine rollover side hill	
Thrown or flying objects—Rotary side-mounted mower. Keep deflector shield in place		Machine rollover up hill	
Severing toes or foot—mower blade		Machine rollover down hill	
Severing fingers or hand—mower blade		Machine rollover ROPS	
Rotating blade can cut off toes or fingers. Stay clear of blade as long as engine is running			
Do not open or remove safety shields while engine is running			

Symbols Glossary

Cutting element–
basic symbol



Cutting element–
height adjustment



Cutting unit–lower

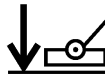

Cutting unit–raised

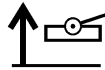

Cutting or entanglement
of foot–Rotating auger



Severing of fingers or hand–
impeller blade



Keep a safe distance from
snowthrower



Stay a safe distance
from the snowthrower

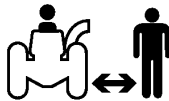

Tractors must be equipped
with 45kg rear wheel weight
with this attachment installed



Machine rollover
ROPS snowthrower



Severing of hand–
Rotating knives



Severing of foot–
Rotating knives



Riding on this machine is allowed
only on a passenger seat & only
if the driver's view is not hindered



Crushing of fingers
or hands–Force applied
from side



Kickback or upward
motion–Stored energy



Shut off engine & remove key
before performing maintenance
or repair work



Machine travel direction–
combined



Low

L

High

H

Reverse

R

Neutral

N

First gear

1



























Second gear

2

Third gear up to
maximum # of
forward gears

3

Symbols Glossary

Fast		Fuel	
Slow		Fuel level	
Decreasing/Increasing		Volume empty	
On/Run		Volume full	
Off/Stop		Battery charging condition	
Engine		Head lights— Main/high beam	
Engine start		Brake system	
Engine stop		Parking brake	
Choke		Clutch	
Engine temperature		PTO (Power Take Off)	
Engine lubricating oil pressure		Engage	
Engine lubricating oil level		Disengage	
		Unlock	
		Lock	

Gasoline and Oil

Recommended Gasoline

Use UNLEADED Regular Gasoline suitable for automotive use (85 pump octane minimum). Leaded regular gasoline may be used if unleaded regular is not available.

IMPORTANT: Never use methanol, gasoline containing methanol, or gasohol containing more than 10% ethanol because the fuel system could be damaged. Do not mix oil with gasoline.

DANGER

POTENTIAL HAZARD

- In certain conditions gasoline is extremely flammable and highly explosive.

WHAT CAN HAPPEN

- A fire or explosion from gasoline can burn you, others, and cause property damage.

HOW TO AVOID THE HAZARD

- Use a funnel and fill the fuel tank outdoors, in an open area, when the engine is cold. Wipe up any gasoline that spills.
- Do not fill the fuel tank completely full. Add gasoline to the fuel tank until the level is 1/4" to 1/2" (6 mm to 13 mm) below the bottom of the filler neck. This empty space in the tank allows gasoline to expand.
- Never smoke when handling gasoline, and stay away from an open flame or where gasoline fumes may be ignited by a spark.
- Store gasoline in an approved container and keep it out of the reach of children. Never buy more than a 30-day supply of gasoline.

Stabilizer/Conditioner

Add the correct amount of gas stabilizer/conditioner to the gas. Using a stabilizer/conditioner in the machine:

- Keeps gasoline fresh during storage
- Cleans the engine while it runs
- Eliminates gum-like buildup in the fuel system, which causes hard starting

IMPORTANT: Never use fuel additives containing methanol or ethanol.

Filling the Fuel Tank

1. Shut the engine off and raise the seat.
2. Clean around the fuel tank cap and remove the cap. Use a funnel and add unleaded regular gasoline to the fuel tank, until the level is 1/4 to 1/2 inch (6 mm to 13 mm) below the bottom of the filler neck. This space in the tank allows gasoline to expand. Do not fill the fuel tank completely full.
3. Install the fuel tank cap securely. Wipe up any gasoline that may have spilled.
4. Low fuel level is viewed through frame in rear of machine.

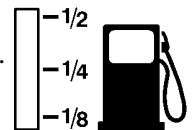

Check Engine Oil Level

Before you start the engine and use the machine, check the oil level in the engine crankcase; refer to Checking Oil Level, page 21.

Operation

Think Safety First

Please carefully read all the safety instructions on pages 2–8. Knowing this information could help you, your family, pets or bystanders avoid injury.

Controls

Become familiar with all the controls (Fig. 1) before you start the engine and operate the machine.

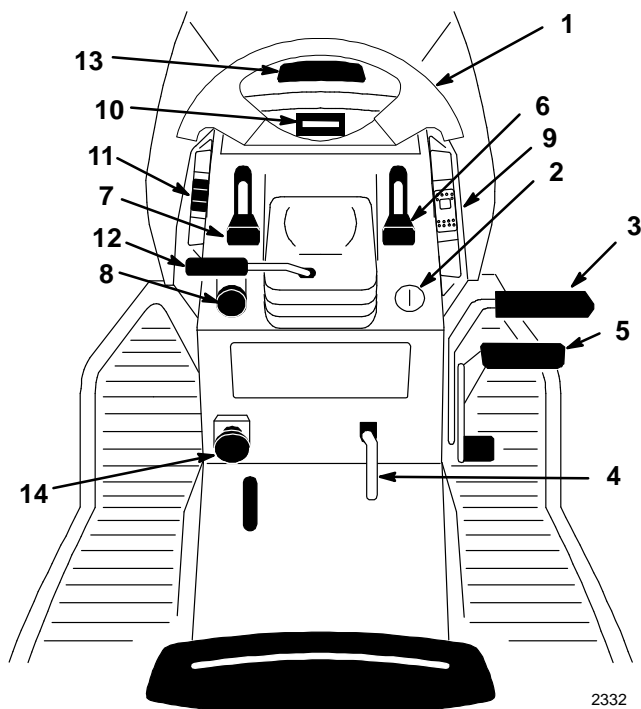

Figure 1

- | | |
|--------------------------|--|
| 1. Steering wheel | 9. Cruise control switch |
| 2. Ignition switch | 10. Indicator control module/Hourmeter |
| 3. Brake pedal | 11. Attachment lift switch |
| 4. Parking brake lever | 12. Tilt wheel lever |
| 5. Ground speed selector | 13. Hood opening |
| 6. Throttle lever | 14. Dial-a-height knob |
| 7. Choke lever | |
| 8. Power take off (PTO) | |

Parking Brake

Always set the parking brake when you stop the machine or leave it unattended.

While the ignition key is in the “RUN” or “LIGHTS” positions and the Parking Brake is engaged, the light, in the Indicator Module, will be lit.

Setting the Parking Brake

1. Push the brake pedal (Fig. 2) down and hold it in the depressed position.
2. Lift the parking brake lever (Fig. 2) up and gradually take your foot off the brake pedal. The brake pedal should stay in the depressed (locked) position.

Releasing the Parking Brake

1. Push down on the brake pedal (Fig. 2). The parking brake lever should release.
2. Gradually release the brake pedal.

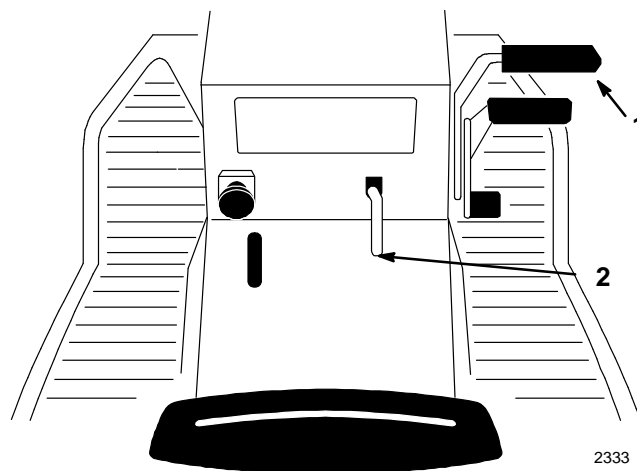

Figure 2

1. Brake pedal
2. Parking brake lever

Starting and Stopping the Engine

Starting

1. Sit down on the seat.
2. Set the parking brake; refer to Setting the Parking Brake, page 10.

Note: The engine will not start unless you set the parking brake or fully depress the brake pedal.

3. Push the PTO (power take off) to “OFF” (Fig. 3).
4. Move the choke lever to “ON” (Fig. 3).

Note: An engine that has been running and is warm may not require step 4.

5. Move throttle lever to “FAST” (Fig. 4).
6. Turn the ignition key clockwise and hold it in the “START” position (Fig. 5). When the engine starts, release the key.

IMPORTANT: If the engine does not start after 30 seconds of continuous cranking, turn the ignition key to “OFF” and let the starter motor cool; refer to Troubleshooting, page 36.

7. After the engine starts, move the choke lever to “OFF” (Fig. 4). If the engine stalls or hesitates, move the choke lever back to “ON” for a few seconds. Then move the throttle lever to desired setting. Repeat this as required.

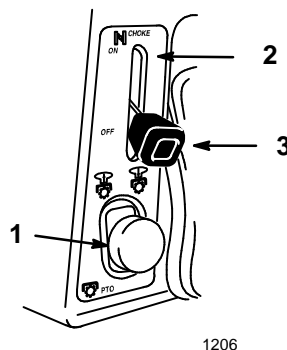

Figure 3

1. PTO—Off
2. Choke—On
3. Choke—Off

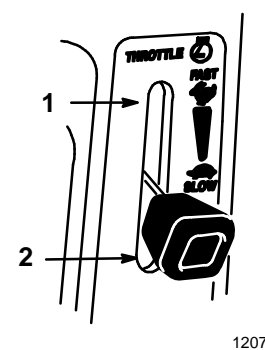

Figure 4

1. Fast
2. Slow

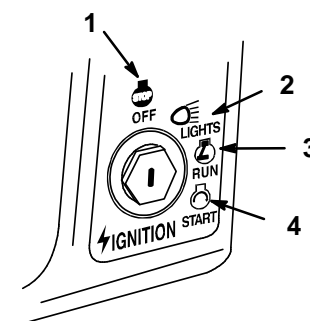

Figure 5

1. Off
2. Lights
3. Run
4. Start

Stopping

1. Move the throttle lever to “SLOW” (Fig. 4).
2. Turn the ignition key to “OFF” (Fig. 5).

Note: If the engine has been working hard or is hot, let it idle for a minute before turning the ignition key “OFF.” This helps cool the engine before it is stopped. In an emergency, the engine may be stopped by turning the ignition key to “OFF.”

Operating the Power Take Off (PTO)

The power take off (PTO) engages and disengages power to the electric clutch.

While the ignition key is in “RUN” or “LIGHTS” position and the power take off (PTO) is engaged “ON”, the PTO light, in the Indicator Module, will be “ON”. When this light is “ON” it is a reminder; the starter will not crank and to turn the off PTO before getting off.

Engaging the Power Take Off (PTO)

1. Depress the brake pedal to stop the machine.
2. Pull the power take off (PTO) to “ON” (Fig. 6).

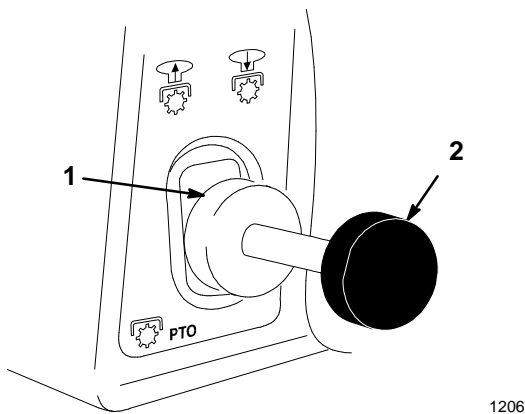

Figure 6

1. Off-Disengaged 2. On-Engaged

Disengaging the Power Take Off (PTO)

1. Depress the brake pedal to stop the machine.
2. Push the power take off (PTO) to “OFF” (Fig. 6).

The Safety Interlock System

Understanding the Safety Interlock System

The safety interlock system is designed to prevent the engine from starting unless:

- You are sitting on the seat
- The brake pedal is depressed
- The power take off (PTO) is “OFF”
- On gear drive models the speed selector lever is in “N” neutral.

The safety interlock system is designed to stop the engine if you rise from the seat when the brake pedal is released or the power take off (PTO) is “ON” or gear selector is not in “N” neutral.

Testing the Safety Interlock System

Test the safety interlock system before you use the machine each time. If the safety system does not operate as described below, have an Authorized Service Dealer repair the safety system immediately.

1. Set the parking brake. Move the power take off (PTO) to “ON”. Now turn the ignition key to “START”; the engine should not crank.
2. Push the power take off (PTO) to “OFF” and release the parking brake. Now turn the ignition key to “START”; the engine should not crank.
3. Set the parking brake and move the power take off (PTO) to “OFF” (On gear drive models the speed selector lever must be in “N” neutral). Now start the engine. While the engine is running, release the parking brake and rise slightly from the seat; the engine should stop.

Indicator Control Module

The indicator control module (optional on some models) (Fig. 7) lights when the parking brake or power take off (PTO), is actuated and when there is a problem of low oil pressure, high engine temperature, alternator output or low fuel level that needs immediate attention.

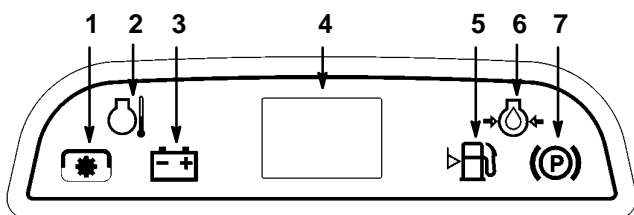

Figure 7

- | | |
|-------------------------|------------------|
| 1. PTO (power take off) | 5. Fuel Level |
| 2. Temperature | 6. Oil |
| 3. Battery | 7. Parking brake |
| 4. Hourmeter | |

Following are the conditions when indicator lights will be “ON”. At other times the lights should be off.

Parking Brake

The parking brake light will be “ON” when the key is in the “RUN” or “LIGHTS” positions and the parking brake is secured with the parking brake lever raised. When this light is “ON” it is a reminder; do not drive machine with parking brake on and set parking brake before getting off machine.

PTO (Power Take Off)

The PTO (power take off) light will be “ON” when the key is in the “RUN” or “LIGHTS” positions and the PTO (power take off) is engaged “ON”. When this light is “ON” it is a reminder; the starter will not crank and turn off the PTO before getting off.

Oil

The oil light will be “ON” when the key is in the “RUN” or “LIGHTS” positions and the engine is not running, after the engine is started the light should go out. When the engine is running if the oil pressure drops below a safe operating level the light comes “ON”. When the light comes on while the engine is running, **Stop engine immediately and correct the cause of low oil pressure.**

Battery

The battery light will be “ON” when the key is in the “RUN” or “LIGHTS” positions if the battery voltage is below 12.6 volts or when the engine is running and the alternator output is above 14.8 volts. When this light comes on it is important to have your battery and electrical system checked and the problem corrected.

Fuel Level

The fuel level light will be “ON” when the key is in the “RUN” or “LIGHTS” positions and the fuel level is low, approximately one pint remaining.

Temperature

The temperature light will be “ON” when the key is in the “RUN” or “LIGHTS” positions and the engine temperature exceeds proper operating limits. **Stop engine immediately and correct the cause of high temperature.**

Hourmeter

The hourmeter (optional on some models) records the number of hours the engine has operated (Fig. 7). It is turned on when the ignition switch is in the “RUN” or “LIGHTS” positions. Use the times for scheduling regular maintenance.

Driving Forward or Backward

The throttle control regulates the engine speed as measured in rpm (revolutions per minute). Place the throttle control in the “FAST” position for best performance.

To go forward or backward, release the parking brake: refer to Releasing the Parking Brake, page 10. Place your foot on the traction control pedal and slowly press on the top of the traction control pedal to move forward or on the bottom of the traction control pedal to move backward (Fig. 8). The farther you move the traction control pedal in either direction, the faster the machine will move in that direction.

To slow down, release the pressure on the traction control pedal.

IMPORTANT: To avoid transmission damage, always release the parking brake before moving the traction control pedal.

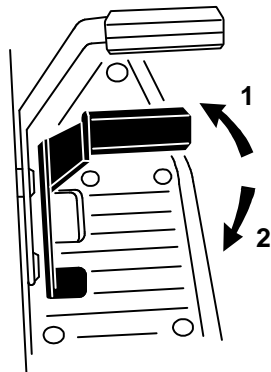

1210

Figure 8

1. Forward

2. Backward

Stopping the Machine

To stop the machine, release the traction control pedal, disengage the power take off (PTO), and turn the ignition key to “OFF” to stop the engine. Also set the parking brake if you leave the machine unattended; refer to Setting the Parking Brake, page 10. Remember to remove the key from the ignition switch.

CAUTION

POTENTIAL HAZARD

- Someone could move or attempt to operate the tractor while it is unattended.

WHAT CAN HAPPEN

- Children or bystanders may be injured if they use the tractor.

HOW TO AVOID THE HAZARD

- Always remove the ignition key and set the parking brake when leaving the machine unattended, even if just for a few minutes.

Attachment Power Lift

The attachment power lift (optional on some models) (Fig. 9) is used to raise and lower attachments.

Raising Attachments

1. Turn key to the “ON” or “RUN” position (Fig. 9).
2. Push the lift switch in the “UP” direction to raise the attachment lift (Fig. 9). This will lift and hold the attachment in the up, or raised position.

Lowering Attachments

1. Turn key to the “ON” or “RUN” position (Fig. 9).
2. Push the lift switch in the “DOWN” direction to lower the attachment lift (Fig. 9). This will lower the attachment lift.

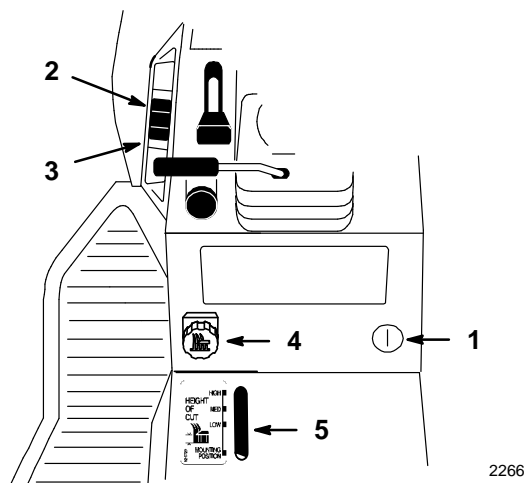

Figure 9

- | | |
|---------------------|----------------------------|
| 1. Key | 4. Dial-A-Height knob |
| 2. Lift switch UP | 5. Dial-A-Height indicator |
| 3. Lift switch DOWN | |

Adjusting Dial-A-Height

The Dial-A-Height control (Fig. 9) is used to limit the downward travel of the attachment. The Dial-A-Height knob is rotated to change the location of this stop, up or down.

1. Raise the attachment lift lever: Refer to Raising Attachments. In the raised position the Dial-A-Height knob (Fig. 9) can be rotated to change the stop location. Turn clockwise to raise and counterclockwise to lower the height of the attachment.
2. The Dial-A-Height indicator (Fig. 9) will show the change, high to low, in attachment lift height as adjustment is made.

Positioning the Seat

The seat can move forward and backward. Position the seat where you have the best control of the machine and are most comfortable.

1. Raise the seat and loosen the adjustment knobs (Fig. 10).
2. Slide the seat to the desired position and tighten the knobs.

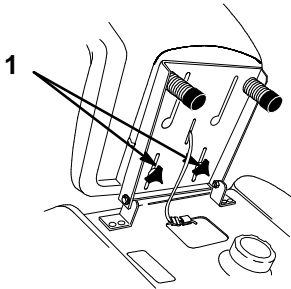

1202

Figure 10

1. Adjustment knob

Positioning the Tilt Steering Wheel

The steering wheel has four tilt locations. Position the steering wheel where you have the best control of the machine and are most comfortable.

1. Lift the tilt lever to release the lock (Fig. 12).
2. Move the steering wheel to a comfortable position; then release the lever to lock.

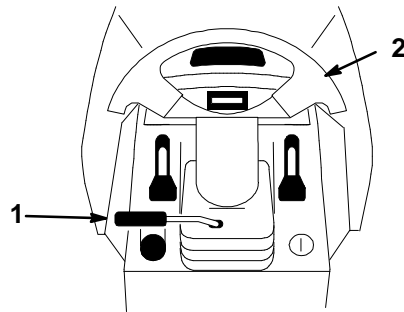

1203b

Figure 12

1. Tilt lever
2. Steering wheel

Headlights

The headlights are turned on with a separate position, “LIGHTS”, of the ignition switch (Fig. 11). The lights are on while the ignition switch is in the “LIGHTS” position even with the engine off. Remove the key when the machine is left unattended so lights can not be turned on discharging the battery.

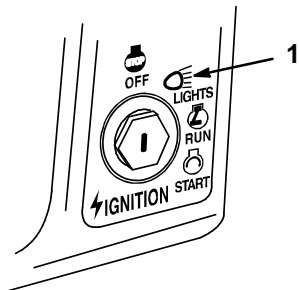

1208

Figure 11

1. Lights

Using the Cruise Control

The cruise control is optional on some models. A 3 position: Lock-Set (spring loaded), On and Off-Unlock dash switch (Fig. 13) controls the engagement. Cruise control maintains the traction control position without foot pressure. Cruise control is intended for operation in the forward direction only. Do not use cruise control in reverse.

Engaging the Cruise Control

1. Begin driving tractor: Refer to Driving Forward or Backward, Page 14. While holding your foot steady on the traction control, push the cruise control switch (Fig. 13) to the “LOCK”-“SET” position.

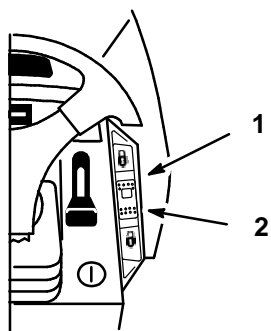

Figure 13

1. Lock-Set
2. Unlock-Off

2. This locks the traction control in position and your foot can then be removed from the traction control. A constant ground speed will be maintained.

Disengaging the Cruise Control

1. While holding your foot steady on the traction control, move the cruise control switch (Fig. 13) to the “UNLOCK”-“OFF” position.
2. This unlocks the traction control and your foot then operates the traction control.
3. For quick stops, just press on the brake pedal. This automatically disengages the cruise control and applies the brake at the same time.

Pushing the Machine by Hand

IMPORTANT: Always push the machine by hand. Never tow the machine because transaxle damage may occur.

To Push the Machine

1. Disengage the power take off (PTO) and turn the ignition key to “OFF” to stop the engine.
2. Move the drive control rod to the “PUSH” position. This disengages the drive system and allows the wheels to turn freely (Fig. 14).

IMPORTANT: Drive control rod moves to the “OPERATE” position when the brake is applied.

To Operate the Machine

1. Apply the brake, this moves the drive control rod to “OPERATE” and engages the drive system, or move the drive control rod to the “OPERATE” position (Fig. 14).

Note: The machine will not drive unless the drive control rod is in the “OPERATE” position.

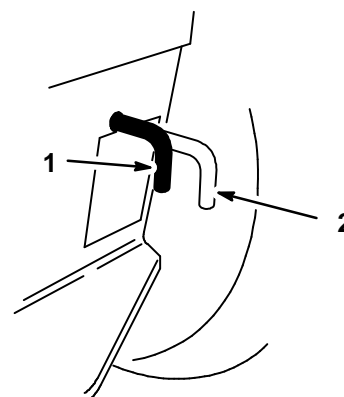

Figure 14

1. Operate position
2. Push position

1209

Maintenance

Service Interval Chart

Service Operation	Each Use	5 Hours	25 Hours	50 Hours	100 Hours	Storage Service	Spring Service
Oil—check level	X						
Oil—change*		Initial			X		
Oil Filter—change* (200 hours, every other oil change or yearly)					X	X	
Safety System—check	X						X
Brake—check	X	X				X	X
Chassis—grease*				X		X	
Foam Air Cleaner—service*			X			X	
Paper Air Cleaner—replace*					X	X	
Spark Plug(s)—check 200 hours						X	X
Belts—check for wear/cracks				X		X	
Gasoline—drain						X	
Engine—clean outside	X		X			X	
Chipped Surfaces—paint						X	
Battery—check electrolyte	X	X				X	X
Battery—charge, disconnect cables						X	
Fuel Filter—replace					X	X	
Tires—check pressure			X			X	X
Front Wheels—check toe-in			X			X	
Power Lift—check fluid			X			X	X
Transaxle Fluid—check level					X	X	X

* More often in dusty, dirty conditions

CAUTION

POTENTIAL HAZARD

- If you leave the key in the ignition switch, someone could start the engine.

WHAT CAN HAPPEN

- Accidental starting of the engine could seriously injure you or other bystanders.

HOW TO AVOID THE HAZARD

- Remove the key from the ignition switch and pull the wire(s) off the spark plug(s) before you do any maintenance. Also push the wire(s) aside so it does not accidentally contact the spark plug(s).

Air Cleaner

Service Interval/Specification

Foam Element: Clean and re-oil after every 25 operating hours, or yearly, whichever occurs first.

Paper Element: Replace after every 100 operating hours or yearly, whichever occurs first.

Note: Service the air cleaner more frequently (every few hours) if operating conditions are extremely dusty or sandy.

Removing the Foam and Paper Elements

1. Disengage the power take off (PTO), set the parking brake, and turn the ignition key to "OFF" to stop the engine. Remove the key.
2. Open the hood.
3. Clean around the air cleaner to prevent dirt from getting into the engine and causing damage. Unhook latches and remove the air cleaner cover (Fig. 15).

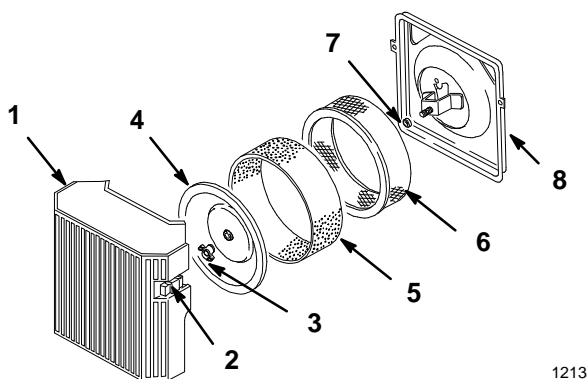

Figure 15

- | | |
|----------------------|---------------------|
| 1. Air cleaner cover | 5. Foam element |
| 2. Latches | 6. Paper element |
| 3. Cover nut | 7. Rubber seal |
| 4. Cover | 8. Air cleaner base |

4. Carefully slide the foam element off the paper element (Fig. 15).
5. Unscrew the cover nut and remove the cover and paper element (Fig. 15).

Cleaning the Foam and Paper Elements

1. Foam Element
 - A. Wash the foam element in liquid soap and warm water. When the element is clean, rinse it thoroughly.
 - B. Dry the element by squeezing it in a clean cloth.
 - C. Put one or two ounces of oil on the element (Fig. 16). Squeeze the element to distribute the oil.

IMPORTANT: Replace the foam element if it is torn or worn.

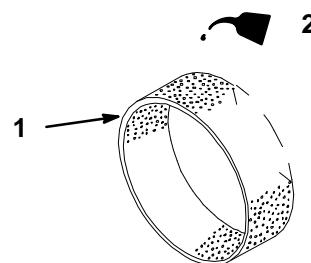

Figure 16

- | | |
|-----------------|--------|
| 1. Foam element | 2. Oil |
|-----------------|--------|

1213

1213

2. Paper Element

- A. Lightly tap the element on a flat surface to remove dust and dirt (Fig. 17).
- B. Inspect the element for tears, an oily film, and damage to the rubber seal.

IMPORTANT: Never clean the paper element with pressurized air or liquids, such as solvent, gas, or kerosene. Replace the paper element if it is damaged, defective, or cannot be cleaned thoroughly.

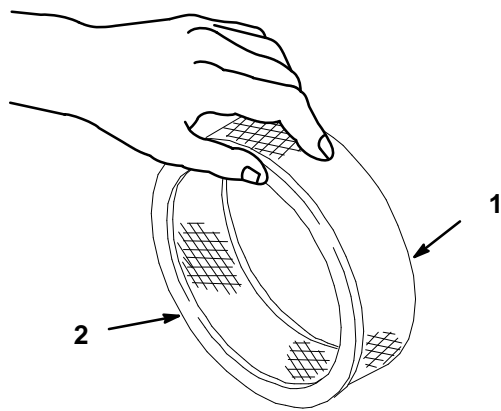

1213

Figure 17

1. Paper element

2. Rubber seal

Installing the Foam and Paper Elements

IMPORTANT: To prevent engine damage, always operate the engine with the complete foam and paper air cleaner assembly installed.

1. Carefully slide the foam element onto the paper air cleaner element (Fig. 15).
2. Slide the air cleaner assembly and cover onto the long rod. Now screw the cover nut finger-tight against the cover (Fig. 15).

Note: Make sure the rubber seal is flat against the air cleaner base and cover.

3. Install the air cleaner cover and hook latches (Fig. 15).
4. Close the hood.

Engine Oil

Service Interval/Specification

Change oil:

- After the first 5 operating hours.
- After every 100 operating hours.

Note: Change oil more frequently when operating conditions are extremely dusty or sandy.

Oil Type: Detergent oil (API service SF or SG)

Crankcase Capacity: w/filter, 4 pints (1.9 l)

Viscosity: See table below

USE THESE SAE VISCOSITY OILS

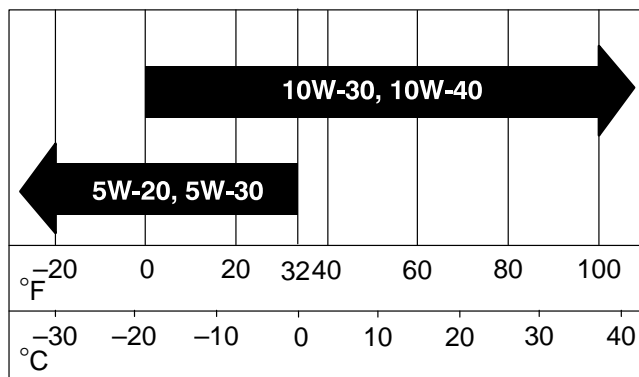

Checking Oil Level

1. Park the machine on a level surface, disengage the power take off (PTO), set the parking brake, and turn the ignition key to “OFF” to stop the engine. Remove the key.
2. Open the hood.
3. Clean around the oil dipstick (Fig. 18) so dirt cannot fall into the filler hole and damage the engine.
4. Unscrew the oil dipstick and wipe the metal end clean (Fig. 18).
5. Slide the oil dipstick fully into the filler tube, do not thread onto tube (Fig. 18). Pull the dipstick out and look at the metal end. If oil level is low, slowly pour only enough oil into the filler tube to raise the level to the “FULL” mark.

IMPORTANT: Do not overfill the crankcase with oil because the engine may be damaged.

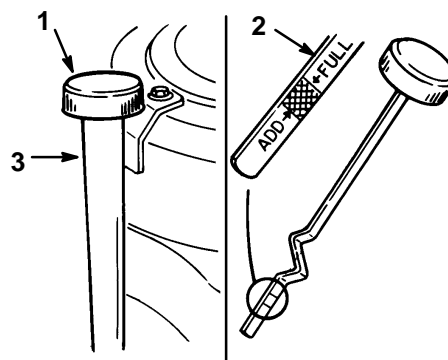

Figure 18

1. Oil dipstick
2. Metal end
3. Filler tube

Changing/Draining Oil

1. Start the engine and let it run five minutes. This warms the oil so it drains better.
2. Park the machine so that the drain side is slightly lower than the opposite side to assure the oil drains completely. Then disengage the power take off (PTO), set the parking brake, and turn the ignition key to "OFF" to stop the engine. Remove the key.
3. Open the hood.
4. Slide a piece of hose over oil drain to direct oil.
5. Place a pan below the oil drain. Open the drain by turning counterclockwise, 1/8 turn, and pull out (Fig. 19).
6. When oil has drained completely, close the drain by pushing in and turning clockwise, 1/8 turn.

Note: Dispose of the used oil at a certified recycling center.

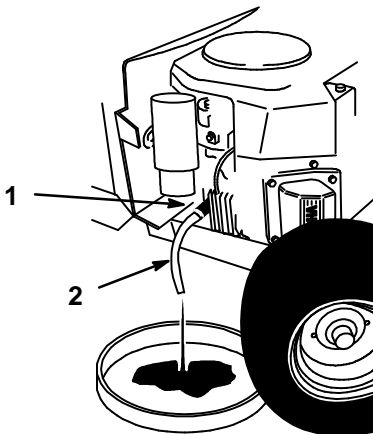

Figure 19

1. Oil drain
2. Hose

1241

Change Oil Filter

Service Interval/Specification

Replace the oil filter every 200 hours or every other oil change.

Note: Change oil filter more frequently when operating conditions are extremely dusty or sandy.

1. Drain the oil from the engine; refer to Changing/Draining Oil, page 22.
2. Remove the old filter and wipe the filter adapter (Fig. 20) gasket surface.
3. Apply a thin coat of new oil to the rubber gasket on the replacement filter (Fig. 20).

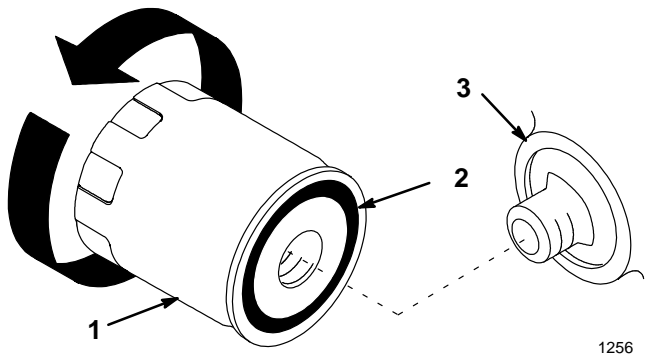

1256

Figure 20

1. Oil filter
2. Gasket
3. Adapter

4. Install the replacement oil filter to the filter adapter. Turn the oil filter clockwise until the rubber gasket contacts the filter adapter, then tighten the filter an additional 1/2 turn (Fig. 20).
5. Fill the crankcase with the proper type of new oil; refer to Changing/Draining Oil, page 22.

7. Slowly pour approximately 80% of the specified amount of oil into the filler tube (Fig. 18). Now check the oil level; refer to Checking Oil Level, page 21. Slowly add additional oil to bring to "FULL" mark on dipstick.

Spark Plug

Service Interval/Specification

Check the spark plug(s) after every 200 operating hours. Make sure the air gap between the center and side electrodes is correct before installing the spark plug. Use a spark plug wrench for removing and installing the spark plug(s) and a gapping tool/feeler gauge to check and adjust the air gap.

Type: Champion RC-12YC (or equivalent)

Air Gap: 0.040" (1.02 mm)

Removing the Spark Plug(s)

1. Disengage the power take off (PTO), set the parking brake, and turn the ignition key to "OFF" to stop the engine. Remove the key.
2. Open the hood.
3. Pull the wire(s) off the spark plug(s) (Fig. 21). Now clean around the spark plug(s) to prevent dirt from falling into the engine and potentially causing damage.
4. Remove the spark plug(s) and metal washer.

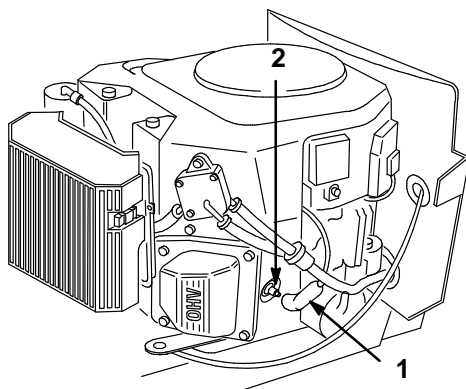

Figure 21

1. Spark plug wire
2. Spark plug

1215

Checking the Spark Plug

1. Look at the center of the spark plug(s) (Fig. 22). If you see light brown or gray on the insulator, the engine is operating properly. A black coating on the insulator usually means the air cleaner is dirty.

IMPORTANT: Never clean the spark plug(s). Always replace the spark plug(s) when it has: a black coating, worn electrodes, an oily film, or cracks.

2. Check the gap between the center and side electrodes (Fig. 22). Bend the side electrode (Fig. 22) if the gap is not correct.

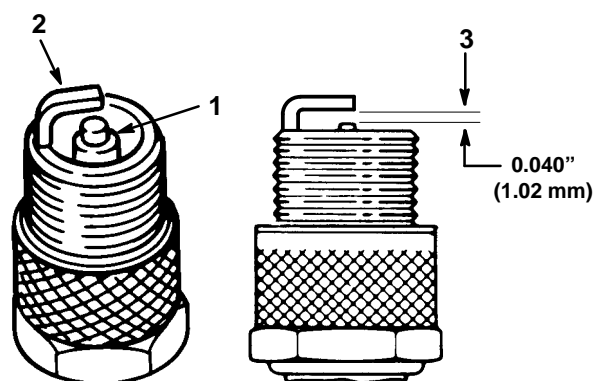

Figure 22

1. Center electrode insulator
2. Side electrode
3. Air gap (not to scale)

Installing the Spark Plug(s)

1. Install the spark plug(s) and metal washer. Make sure the air gap is set correctly.
2. Tighten the spark plug(s) to 20 ft-lb (27 Nm).
3. Push the wire(s) onto the spark plug(s) (Fig. 21).
4. Close the hood.

Greasing and Lubrication

Service Interval/Specification

Grease the machine after every 50 operating hours or yearly, whichever occurs first. Grease more frequently when operating conditions are extremely dusty or sandy.

Grease Type: General-purpose grease.

How to Grease

1. Disengage the power take off (PTO), set the parking brake, and turn the ignition key to "OFF" to stop the engine. Remove the key.
2. Clean the grease fittings with a rag. Make sure to scrape any paint off the front of the fitting(s).
3. Connect a grease gun to the fitting. Pump grease into the fittings until grease begins to ooze out of the bearings.
4. Wipe up any excess grease.

Where to Add Grease

1. Lubricate the front wheels and spindles until grease begins to ooze out of the bearings (Fig. 23).
2. Lubricate the front axle pivot (Fig. 23).

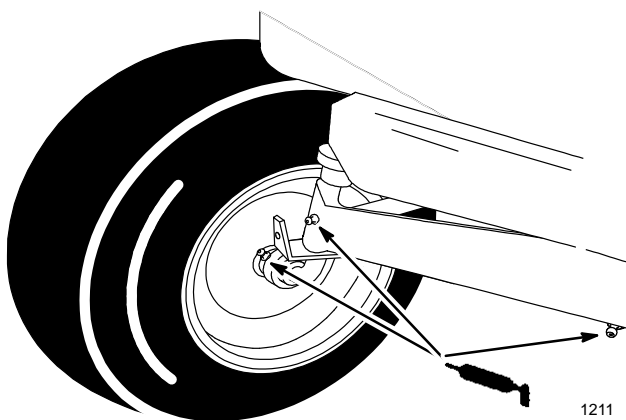

Figure 23

3. Lubricate the traction control pedal on hydrostatic models (or brake and clutch pedals on gear drive models) where they pivot on mounting shaft (Fig. 24).

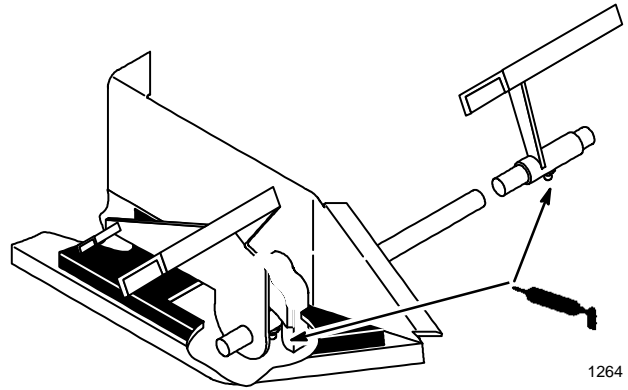

Figure 24

Tire Pressure

Service Interval/Specification

Maintain the air pressure in the front and rear tires as specified. Check the pressure at the valve stem after every 25 operating hours or monthly, whichever occurs first (Fig. 25). Check the tires when they are cold to get the most accurate pressure reading.

Pressure: 12 psi (.85 kPa) front and rear

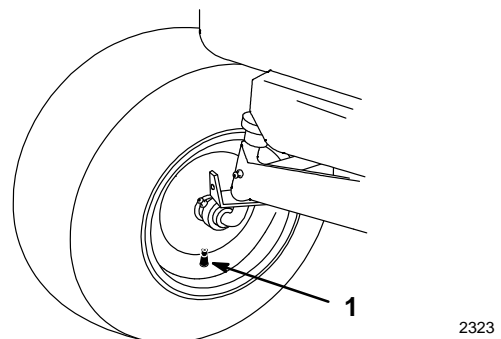

Figure 25

1. Valve stem

Brake

Always set the parking brake when you stop the machine or leave it unattended. If the parking brake does not hold securely, an adjustment is required.

Checking the Brake

1. Park the machine on a level surface, disengage the power take off (PTO), set the parking brake, and turn the ignition key to “OFF” to stop the engine. Remove the key.
2. Rear wheels must lock and skid when you try to push the tractor forward. Adjustment is required if the wheels turn and do not lock; refer to Adjusting the Brake, page 25.
3. Move the drive control rod to the “PUSH” position; refer to Pushing the Machine by Hand, page 17. Wheels should rotate freely.
4. If both conditions are met no adjustment is required.

IMPORTANT: Drive control rod moves to the “OPERATE” position when the brake is applied.

Adjusting the Brake

The brake lever is on top of the transaxle (Fig. 26). If the parking brake does not hold securely, an adjustment is required.

1. Check the brake before you adjust it; refer to Checking the Brake, page 25.
2. Release the parking brake; refer to Releasing the Parking Brake, page 10.
3. To adjust the brake remove the cotter pin and washer from the brake lever (Fig. 26).
4. Rotate the trunnion so it smoothly slides into brake lever (Fig. 26).
5. Secure trunnion to brake lever with washer and cotter pin (Fig. 26).
6. Check the brake operation again; refer to Checking the Brake, page 25.

IMPORTANT: With the parking brake released, the rear wheels must rotate freely when you push the mower. If brake action and free wheel rotation cannot be achieved contact your service dealer immediately.

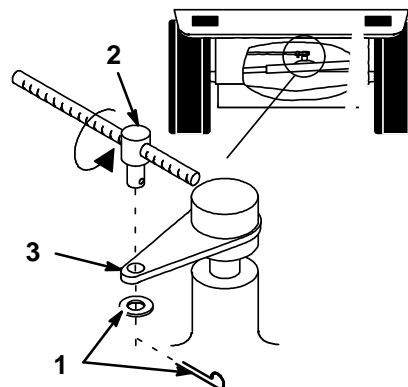



Figure 26

- | | |
|--------------------------|----------------|
| 1. Cotter pin and washer | 3. Brake lever |
| 2. Trunnion | |

1245

Fuel Tank

Draining The Fuel Tank

DANGER

POTENTIAL HAZARD

- In certain conditions gasoline is extremely flammable and highly explosive.

WHAT CAN HAPPEN

- A fire or explosion from gasoline can burn you, others, and cause property damage.

HOW TO AVOID THE HAZARD

- Drain gasoline from the fuel tank when the engine is cold. Do this outdoors in an open area. Wipe up any gasoline that spills.
- Never drain gasoline near an open flame or where gasoline fumes may be ignited by a spark.
- Never smoke a cigarette, cigar or pipe.

1. Park the machine on a level surface, to assure fuel tank drains completely. Then disengage the power take off (PTO), set the parking brake, and turn the ignition key to "OFF" to stop the engine. Remove the key.
2. Close fuel shut-off valve at fuel tank (Fig. 27).

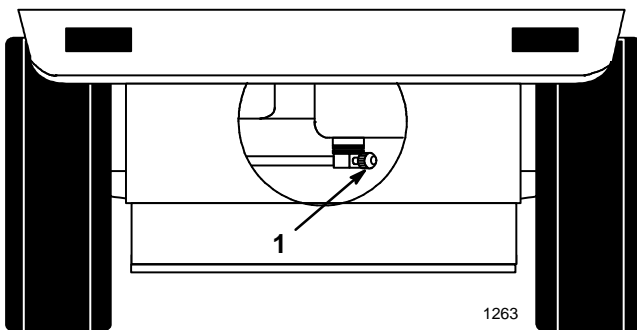

Figure 27

1. Fuel shut-off valve

3. Open the hood.
4. Squeeze the ends of the hose clamp together and slide it up the fuel line toward the fuel tank (Fig. 28).

5. Pull the fuel line off the filter (Fig. 28). Open fuel shut-off valve and allow gasoline to drain into a gas can or drain pan.

Note: Now is the best time to install a new fuel filter because the fuel tank is empty.

6. Install the fuel line onto the filter. Slide the hose clamp close to the filter to secure the fuel line and filter. Refer to Replacing the Fuel Filter; page 27.

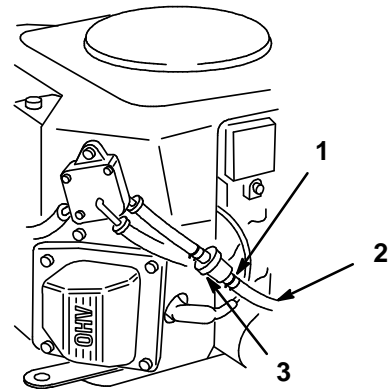

Figure 28

1. Hose clamp
2. Fuel line
3. Filter

Fuel Filter

Service Interval/Specification

Replace the fuel filter after every 100 operating hours or yearly, whichever occurs first.

Replacing the Fuel Filter

Never install a dirty filter if it is removed from the fuel line.

1. Disengage the power take off (PTO), set the parking brake, and turn the ignition key to "OFF" to stop the engine. Remove the key.
2. Close fuel shut-off valve at fuel tank (Fig. 27).
3. Open the hood.
4. Squeeze the ends of the hose clamps together and slide them away from the filter (Fig. 29).
5. Remove the filter from the fuel lines.

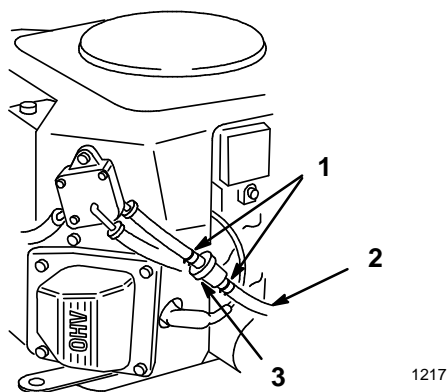

Figure 29

- | | |
|---------------|-----------|
| 1. Hose clamp | 3. Filter |
| 2. Fuel line | |

6. Install a new filter and move the hose clamps close to the filter.
7. Open fuel shut-off valve at fuel tank (Fig. 27).
8. Close the hood.

Power Lift

Service Interval/Specification

Check fluid level in power lift after every 25 operating hours or yearly, whichever occurs first. Fill with Dexron Type II or Type III automatic transmission fluid.

Checking Fluid Level

1. Raise attachment lift to the full "UP" position. Refer to: Raising Attachments page .
2. Disengage the power take off (PTO), set the parking brake, and turn the ignition key to "OFF" to stop the engine. Remove the key.
3. Open the hood.
4. Remove the plug on top of the power lift pump (Fig. 30). Fluid should be level with the bottom of the hole.
5. If fluid is below bottom of the hole fill with Dexron Type II or Type III automatic transmission fluid.

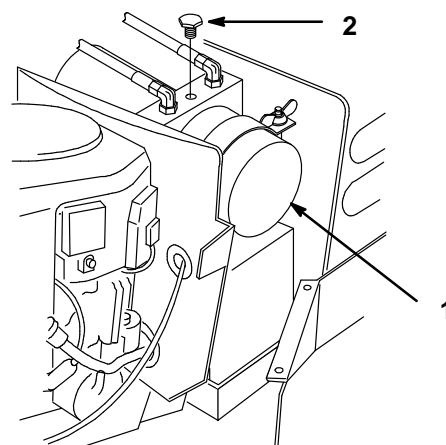

Figure 30

- | | |
|--------------------|---------|
| 1. Power lift pump | 2. Plug |
|--------------------|---------|

Front Wheel Toe-In

Service Interval/Specification

Maintain toe-in of the front wheels as specified. If uneven tire wear, lawn scuffing or hard steering develop adjustment may be required. Check the toe-in after every 100 operating hours or yearly, whichever occurs first (Fig. 31).

Specification: 1/8–1/4 inch toe-in on front wheels.

Measuring Toe-in

1. Disengage the power take off (PTO), set the parking brake, and turn the ignition key to “OFF” to stop the engine. Remove the key.
2. Push front tires out, at front, to remove normal looseness in the linkage.
3. Measure, between the rims, at spindle level, in the front and rear of the wheels (Fig. 31).
4. The front measurement should be less than the rear, as specified.

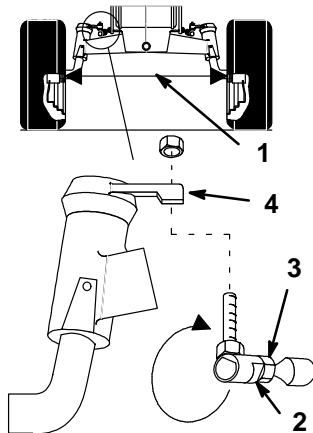

Figure 31

- | | |
|---------------------|-------------------|
| 1. Measure here | 3. Jam nut |
| 2. Ball joint flats | 4. Steering lever |

Adjusting Toe-In

1. Check the toe-in before you adjust it; refer to Measuring Toe-In, Page 28.
2. Remove ball joint from one steering lever (Fig. 31).
3. Loosen jam nut securing ball joint to steering rod. Rotate ball joint one turn, clockwise to increase or counter clockwise to decrease toe-in.
4. Hold flats on ball joint to align with flats on tie rod and tighten jam nut.
5. Install ball joint to steering lever and check the toe-in; refer to Measuring Toe-In, Page 32.

IMPORTANT: If more than one turn is required to meet specifications, alternate between left and right steering rods to maintain steering wheel alignment.

Transaxle Fluid

Service Interval/Specification

Check fluid level after every 100 hours or yearly whichever comes first. Always keep the fluid level at the full level when the transaxle is cold. The transaxle is a sealed system and no changing of the fluid is required.

Fluid Type: SAE 10W-30 Detergent oil (API service SF or SG)

Checking Fluid Level

1. Park the machine on a level surface, disengage the power take off (PTO), set the parking brake, and turn the ignition key to "OFF" to stop the engine. Remove the key.
2. Open the hood.
3. Clean around the fluid reservoir (Fig. 32) so level is clearly visible and so dirt cannot fall into the reservoir if fluid is added.
4. When transaxle is cold add oil to "Full Cold" line on reservoir (Fig. 32).

IMPORTANT: Do not fill above the full cold line as fluid may overflow.

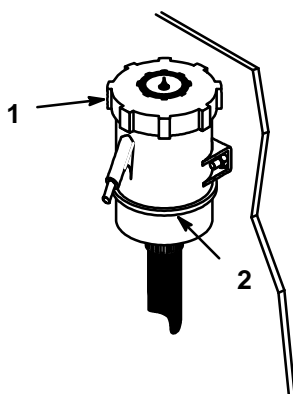

Figure 32

1. Fluid reservoir
2. Full cold level

Fuse

Service Interval/Specification

The electrical system is protected by fuses. It requires no maintenance, however, if a fuse blows check component/circuit for malfunction or short. To replace fuses pull up on the fuse (Fig. 33) to remove or replace it.

- Fuse:
- Dash and Cruise control F1-5 amp, blade-type
 - Head lights F2-10 amp, blade-type
 - Regulator F3-25 amp, blade-type
 - Main F4-30 amp, blade-type
 - Lift F5-25 amp, blade-type

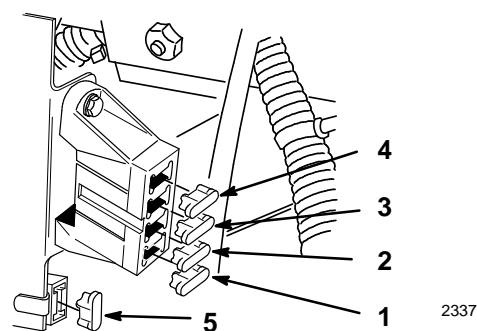

Figure 33

1. Dash and Cruise control -5 Amp
2. Head lights-10 amp
3. Regulator-25 amp
4. Main-30 amp
5. Lift 25 amp

Headlights

Specification: Bulb # 1156 Automotive Type

Removing the Bulb

1. Disengage the power take off (PTO), set the parking brake, and turn the ignition key to "OFF" to stop the engine. Remove the key.
2. Open the hood. Pull wire connectors off both bulb holder terminals.
3. Rotate the bulb holder 1/4 turn counterclockwise and remove it from the reflector (Fig. 34).
4. Push and rotate the bulb counterclockwise until it stops (approx. 1/4 turn) and remove bulb from the bulb holder (Fig. 35).

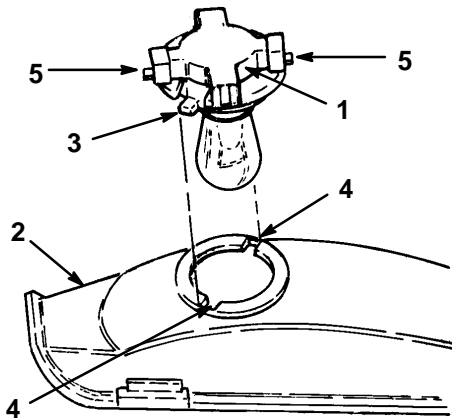

Figure 34

- | | |
|----------------|--------------|
| 1. Bulb holder | 4. Slots |
| 2. Reflector | 5. Terminals |
| 3. Tabs | |
-

Installing the Bulb

1. The bulb has metal pins on the side of its base. Align the pins with the slots in the bulb holder and insert the base into the holder (Fig. 35). Push and rotate the bulb clockwise until it stops.

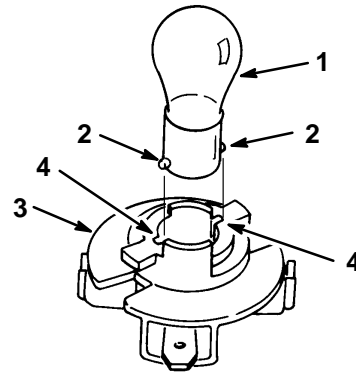

Figure 35

- | | |
|---------------|----------------|
| 1. Bulb | 3. Bulb holder |
| 2. Metal pins | 4. Slots |
-

2. The bulb holder has two tabs (Fig. 34). Align the tabs with the slots in the reflector, insert the bulb holder into the reflector and rotate it 1/4 turn clockwise until it stops.
3. Push the wire connectors onto the terminals on the bulb holder.

Battery

Service Interval/Specification

Check the electrolyte level in the battery before each use. Always keep the battery clean and fully charged. Use a paper towel to clean the battery case. If the battery terminals are corroded, clean them with a solution of four parts water and one part baking soda. Apply a light coating of grease to the battery terminals to prevent corrosion.

Voltage: 12 v, 280 Cold Cranking Amps

Removing the Battery

1. Disengage the power take off (PTO), set the parking brake, and turn the ignition key to "OFF" to stop the engine. Remove the key.
2. Open the hood to see the battery.
3. Remove side panels for clearance when removing battery (Fig. 37). Remove the wing nuts and screws and lift up to clear pin and slide panel tabs out from steering tower.
4. Disconnect the negative (black) ground cable from the battery post (Fig. 36).
5. Lift the rubber cover up on the positive (red) cable. Disconnect the positive (red) cable from the battery post (Fig. 36).
6. Remove the battery hold down rods (Fig. 36).

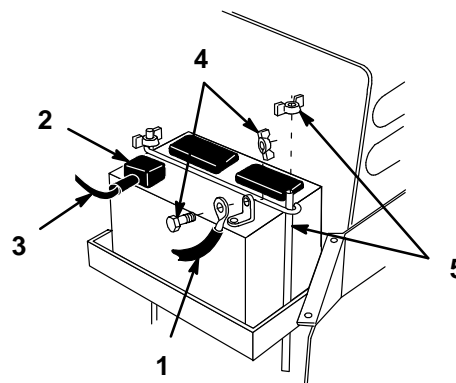

Figure 36

- | | |
|---------------------------|-------------------------------|
| 1. Negative cable (black) | 4. Bolt and wing nut |
| 2. Rubber cover | 5. Hold down rod and wing nut |
| 3. Positive cable (red) | |

Installing the Battery

7. Install the battery into the chassis (Fig. 37).
8. Secure battery in chassis with hold down rods.
9. Using the bolt and wing nut, connect the positive (red) cable to the positive (+) battery post (Fig. 36). Slide the rubber cover over the battery post.
10. Using the bolt and wing nut, connect the negative (black) cable to the negative (-) battery post (Fig. 36).
11. Install side panels by sliding tabs into steering tower and inserting pin into flange of footrest. Secure with screws and wing nuts (Fig. 37).

1219

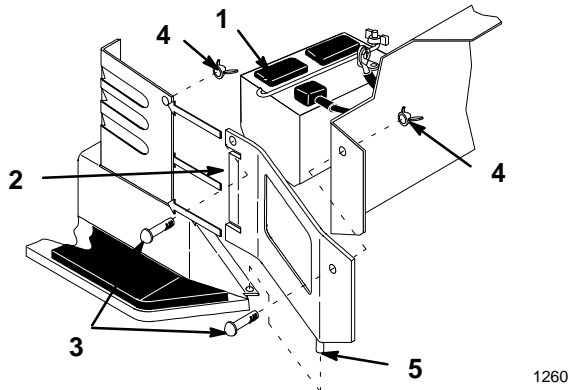

Figure 37

- 1. Battery
- 2. Side panel tabs
- 3. Screw
- 4. Wing nut
- 5. Pin

1260

Adding Water to the Battery

The best time to add distilled water to the battery is just before you operate the machine. This lets the water mix thoroughly with the electrolyte solution.

1. Clean the top of the battery with a paper towel.
2. Lift off the filler caps (Fig. 38).
3. Slowly pour distilled water into each battery cell until the level is up to the lower part of the tube (Fig. 38).

IMPORTANT: Do not overfill the battery because electrolyte (sulfuric acid) can cause severe corrosion and damage to the chassis.

4. Press the filler caps onto the battery.

Checking Electrolyte Level

1. With the engine off, open the hood to see the battery.
2. Open covers to see into the cells. The electrolyte must be up to the lower part of the tube (Fig. 38). Do not allow the electrolyte to get below the plates. (Fig. 38).
3. If the electrolyte is low, add the required amount of distilled water; refer to Adding Water to the Battery, page 32.

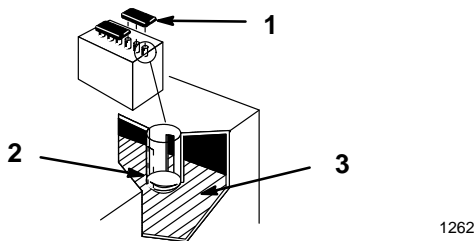

Figure 38

- 1. Filler caps
- 2. Lower part of tube
- 3. Plates

1262

Charging the Battery

IMPORTANT: Always keep the battery fully charged (1.260 specific gravity). This is especially important to prevent battery damage when the temperature is below 32°F (0°C).

1. Remove the battery from the chassis; refer to Removing the Battery, page 31.
2. Check the electrolyte level; refer to Checking Electrolyte Level, page 32, steps 2–3.
3. Remove the filler caps from the battery and connect a 3 to 4 amp battery charger to the battery posts. Charge the battery at a rate of 4 amperes or less for 4 hours (12 volts). Do not overcharge the battery. Install the filler caps after the battery is fully charged.

WARNING

POTENTIAL HAZARD

- Charging the battery produces gasses.

WHAT CAN HAPPEN

- Battery gasses can explode.

HOW TO AVOID THE HAZARD

- Keep cigarettes, sparks and flames away from battery.

4. Install the battery in the chassis; refer to Installing the Battery, page 31.

Wiring Diagram

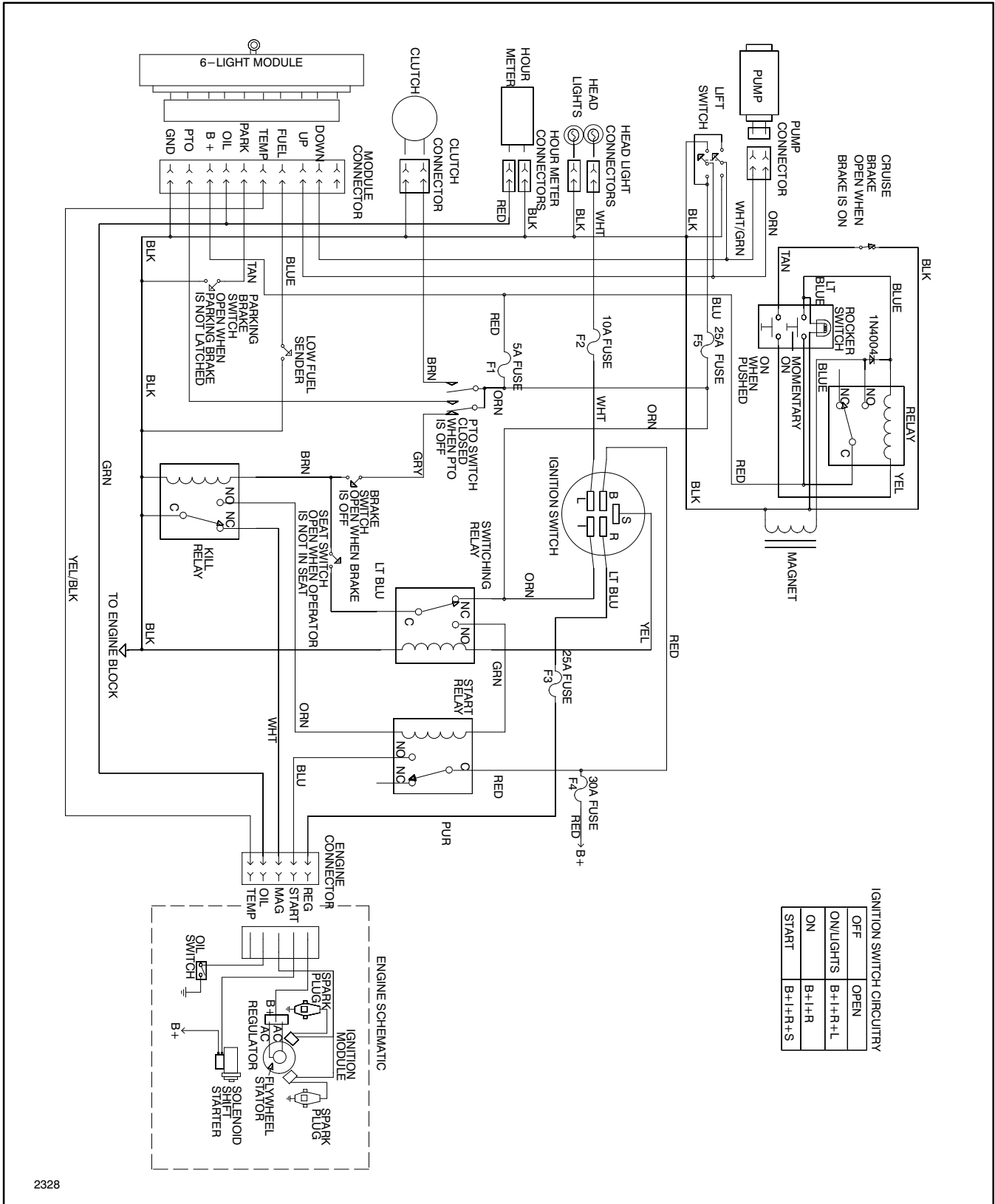

2328

Cleaning and Storage

1. Disengage the power take off (PTO), set the parking brake, and turn the ignition key to “OFF” to stop the engine. Remove the key.
2. Remove grass clippings, dirt, and grime from the external parts of the entire machine, especially the engine. Clean dirt and chaff from the outside of the engine’s cylinder head fins and blower housing.

IMPORTANT: You can wash the machine with mild detergent and water. Do not pressure wash the machine. Avoid excessive use of water, especially near the control panel, lights, engine, and the battery.

3. Check the brake; refer to Brake, page 24.
4. Service the air cleaner; refer to Air Cleaner, page 19.
5. Grease the chassis; refer to Greasing and Lubrication, page 24.
6. Change the crankcase oil; refer to Engine Oil, page 21.
7. Remove the spark plug(s) and check its condition; refer to Spark Plug, page 23. With the spark plug(s) removed from the engine, pour two tablespoons of engine oil into the spark plug hole. Now use the electric starter to crank the engine and distribute the oil inside the cylinder. Install the spark plug(s) and tighten it to 15 ft–lb (20.4 Nm). Do not install the wire on the spark plug(s).
8. Remove the battery from the chassis, check the electrolyte level, and charge it fully; refer to Battery, page 31. Do not connect the battery cables to the battery posts during storage.

IMPORTANT: The battery must be fully charged to prevent it from freezing and being damaged at temperatures below 32°F (0°C). A fully charged battery maintains its charge for about 50 days at temperatures lower than

40°F (4°C). If the temperatures will be above 40°F (4°C), check the water level in the battery and charge it every 30 days.

9. Check the tire pressure; refer to Tire Pressure, page 24.
10. During long-term storage, either drain gasoline from the fuel tank (step A) or add a fuel stabilizer/conditioner additive to a full tank of gasoline (step B).
 - A. Drain gasoline from the fuel tank; refer to Fuel Tank, page 26. After fuel is drained, start the engine and let it idle until all gasoline is consumed and the engine stops. This eliminates gum-like buildup in the fuel system, which causes hard starting. Try to start the engine two more times to assure that no gasoline is in the fuel system.
 - B. Add the correct amount of a fuel stabilizer/conditioner to a full tank of gasoline.

Note: Stabilizer/conditioners normally preserve gasoline for six to eight months.

11. Check and tighten all bolts, nuts, and screws. Repair or replace any part that is damaged or defective.
12. Paint all scratched or bare metal surfaces. Paint is available from your Authorized Service Dealer.
13. Store the machine in a clean, dry garage or storage area. Remove the key from the ignition switch and keep it in a memorable place. Cover the machine to protect it and keep it clean.

Troubleshooting

PROBLEM	POSSIBLE CAUSES	CORRECTIVE ACTION
Starter does not crank	<ol style="list-style-type: none"> 1. Blade control (PTO) is ENGAGED. 2. Parking brake is not on. 3. Operator is not seated. 4. Battery is dead. 5. Electrical connections are corroded or loose. 6. Fuse is blown. 7. Relay or switch is defective. 	<ol style="list-style-type: none"> 1. Move blade control (PTO) to DISENGAGED. 2. Set parking brake. 3. Sit on the seat. 4. Charge the battery. 5. Check electrical connections for good contact. 6. Replace fuse. 7. Contact Authorized Service Dealer.
Engine will not start, starts hard, or fails to keep running.	<ol style="list-style-type: none"> 1. Fuel tank is empty. 2. Choke is not ON. 3. Air cleaner is dirty. 4. Spark plug wire is loose or disconnected. 5. Spark plug is pitted, fouled, or gap is incorrect. 6. Dirt in fuel filter. 7. Dirt, water, or stale fuel is in fuel system. 	<ol style="list-style-type: none"> 1. Fill fuel tank with gasoline. 2. Move choke lever to ON. 3. Clean or replace air cleaner element. 4. Install wire on spark plug. 5. Install new, correctly gapped spark plug. 6. Replace fuel filter. 7. Contact Authorized Service Dealer.
Engine loses power.	<ol style="list-style-type: none"> 1. Engine load is excessive. 2. Air cleaner is dirty. 3. Oil level in crankcase is low. 4. Cooling fins and air passages under engine blower housing are plugged. 5. Spark plug is pitted, fouled, or gap is incorrect. 6. Vent hole in fuel cap is plugged. 7. Dirt in fuel filter. 8. Dirt, water, or stale fuel is in fuel system. 	<ol style="list-style-type: none"> 1. Reduce ground speed. 2. Clean air cleaner element. 3. Add oil to crankcase. 4. Remove obstruction from cooling fins and air passages. 5. Install new, correctly gapped spark plug. 6. Clean or replace the fuel cap. 7. Replace fuel filter. 8. Contact Authorized Service Dealer.

PROBLEM	POSSIBLE CAUSES	CORRECTIVE ACTION
Engine overheats.	<ol style="list-style-type: none"> 1. Engine load is excessive. 2. Oil level in crankcase is low. 3. Cooling fins and air passages under engine blower housing are plugged. 	<ol style="list-style-type: none"> 1. Reduce ground speed. 2. Add oil to crankcase. 3. Remove obstruction from cooling fins and air passages.
Abnormal vibration.	<ol style="list-style-type: none"> 1. Engine mounting bolts are loose. 2. Loose engine pulley, idler pulley, or blade pulley. 3. Engine pulley is damaged. 	<ol style="list-style-type: none"> 1. Tighten engine mounting bolts. 2. Tighten the appropriate pulley. 3. Contact Authorized Service Dealer.
Machine does not drive.	<ol style="list-style-type: none"> 1. Drive control is in "PUSH" position. 2. Traction belt is worn, loose or broken. 3. Traction belt is off pulley. 	<ol style="list-style-type: none"> 1. Move drive control to "OPERATE" position. 2. Contact Authorized Service Dealer. 3. Contact Authorized Service Dealer.

