



**Count on it.**

**Parts Catalog**

**41cm Recycler®**

**Lawn Mower**

Model No. 21131—Serial No. 315000001 and Up



# Ordering Replacement Parts

To order replacement parts, please supply the part number, the quantity, and the description of each part desired.

## Understanding Reference Numbers

Each identified part in an illustration has a reference number. The reference number for a part also appears in the parts list, along with other information about the part.

This catalog uses two special reference number formats, one to indicate parts in a service assembly and another to indicate the quantity of a given part in an illustration.

## Service Assembly Reference Numbers

Parts in service assemblies have reference numbers in the form a:b. The a represents the reference number of the entire service assembly and the b represents a sequential number unique to each part within the service assembly.

For example, a wheel assembly might be identified by reference number 6, the tire by 6:1, the valve by 6:2, and the wheel by 6:3. When you order the assembly identified by reference number 6, you receive all parts identified by reference numbers 6:1, 6:2, and 6:3. However, you may also order any part individually. Reference numbers of this type appear in illustration and in parts lists.

## Reference Numbers Indicating Quantity

In an illustration, if a reference number indicates more than one part, the reference number has the form nX y. The n represents the quantity of the part, the X is the multiplication symbol, and the y represents the reference number.

For example, in an illustration, the reference number 2X 37 means that two of the parts identified by reference number 37 are indicated.

# List of Abbreviations

**AR:** as required

**ASM:** assembly

**BBC:** blade brake control

**BHTF:** button head thread forming

**CARR:** carriage

**CCW:** counter clockwise

**CW:** clockwise

**DEG:** degrees

**DPA:** Dual Point Adjustment

**ECM:** electronic control module

**EXT:** external

**FH:** flat head

**GA:** gauge

**HD:** heavy-duty

**HF:** hex flange

**HH:** hex head

**HHF:** hex head flange

**HHFTF:** hex head flange thread forming

**HJ:** hex jam

**HLH:** hex lag head

**HOC:** height-of-cut

**HP:** high pressure

**HSBH:** hex socket button head

**HSFH:** hex socket flat head

**HSH:** hex socket head

**HWH:** hex washer head

**HWTF:** hex washer head thread forming

**HYD:** hydraulic

**LH:** left hand

**LP:** low pressure

**LPG:** Liquefied Petroleum Gas

**NI:** nylon insert

**NPTF:** national pipe thread fine

**PFH:** phillips flat head

**PPH:** phillips pan head

**PPHTF:** phillips pan head thread forming

**PRH:** phillips round head

**PTH:** phillips truss head

**PTO:** power-take-off

**RH:** right hand

**ROPS:** roll-over protection system

**RRB:** rear roller brush

**SFH:** slotted fillister head

**SHH:** slotted hex head

**SHWH:** slotted hex washer head

**SPH:** slotted pan head

**SQH:** square head

**SRH:** slotted round head

**STD:** standard

**TAP:** self tapping

**TTH:** torx truss head

# Contents

Engine, Chassis, Handle and Bag Assembly..... 4  
Deck, Wheel and Blade Assembly..... 6

# Engine, Chassis, Handle and Bag Assembly

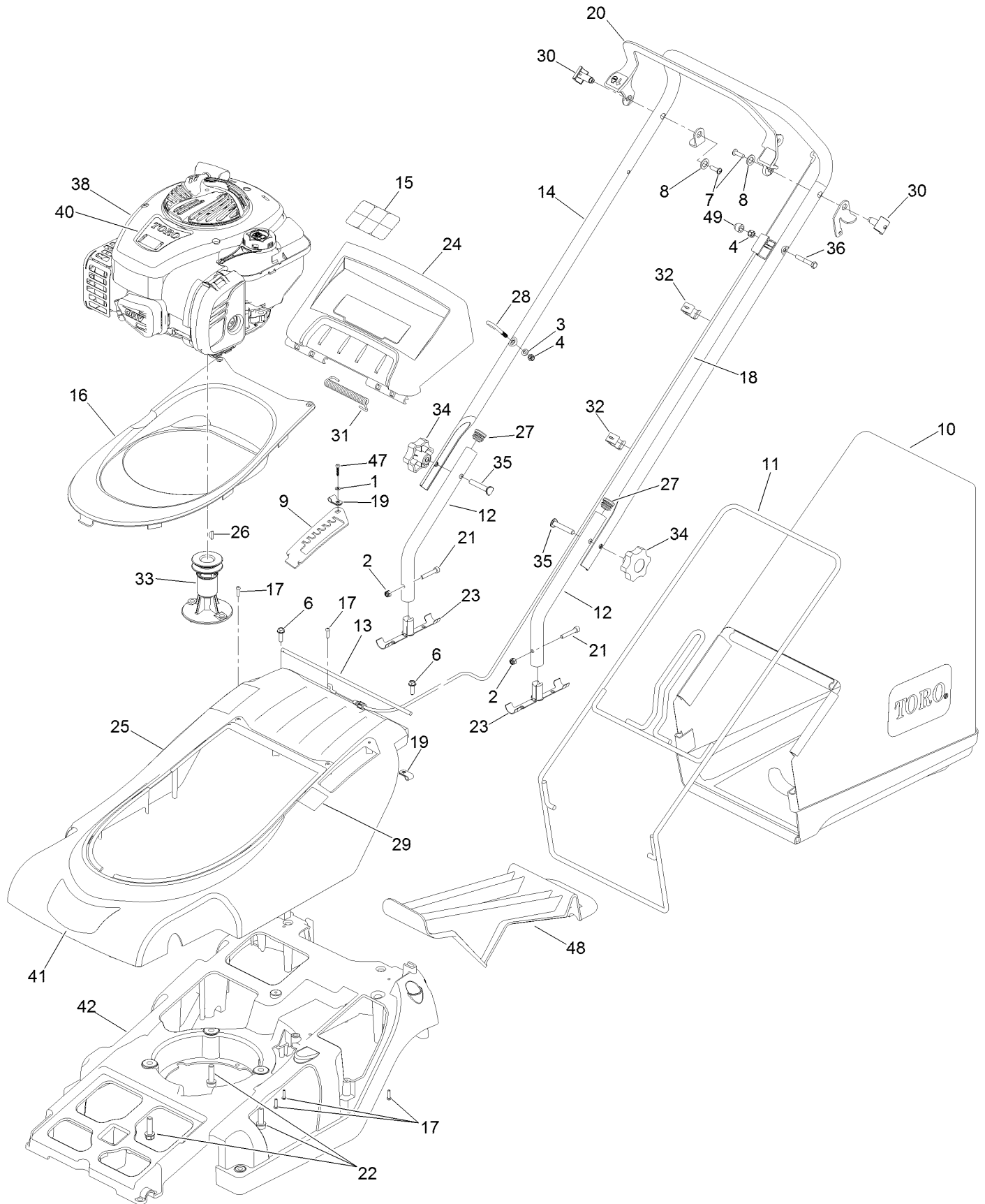

## Engine, Chassis, Handle and Bag Assembly (continued)

<i>Ref.</i>	<i>Part Number</i>	<i>Qty.</i>	<i>Description</i>	<i>Ref.</i>	<i>Part Number</i>	<i>Qty.</i>	<i>Description</i>
1	09658	1	Washer	24	111-1043	1	Moulding-Deflector, Rear
2	09438	1	Nut-Nyloc	25	111-3978	1	Top-Cover
3	09472	1	Washer-Plain	26	1662	1	Key-Woodruff
4	09544	2	Nut-Nyloc	27	300160	2	Plug-Tube
6	09575	2	Screw-Taptite	28	305093	1	Guide-Rope
7	09687	2	Screw	29	320006	1	Decal-HOC
8	09688	6	Washer-Nylon	30	340182	2	Pin-Pivot
9	111-0040	1	Plate-HOC	31	410030	1	Spring-Deflector
10	111-4025	1	Grassbag	32	410037	2	Guide-Cable
11	111-0045-03	1	Frame-Grassbag	33	410078	1	Carrier-Blade
12	111-0051-03	2	Handlebars-Lower	34	480088	2	Knob-Handlebar
13	111-0056	1	Bar-Hinge	35	HY226024	2	Bolt-Handlebar
14	111-0079-03	1	Handlebars	36	ZBH1F040U	1	Screw-HH
15	111-0083	1	Decal-Safety	38		1	Engine-Briggs, 09P7020022H1 ● ■
16	111-0089	1	Moulding-Trim				
17	111-0094	5	Screw	40	111-5433	1	Decal-Engine
18	111-0096	1	Cable-Brake, Engine	41	111-5432	1	Decal-Recycle
19	111-0098	1	Clip-P	42	111-0031-07	1	Chassis
20	340179	1	Lever-Engine	47	111-6806	1	Screw-Plastite
21	111-0118	2	Screw-Socket	48	111-4382	1	Plug-Mulching
22	09349	3	Screw-Taptite, Unc	49	343025	1	Cap-Plastic
23	111-0960	2	Plug-Handlebar				

● Not serviced separately

■ Obtain parts from [www.briggsandstratton.com](http://www.briggsandstratton.com)

# Deck, Wheel and Blade Assembly

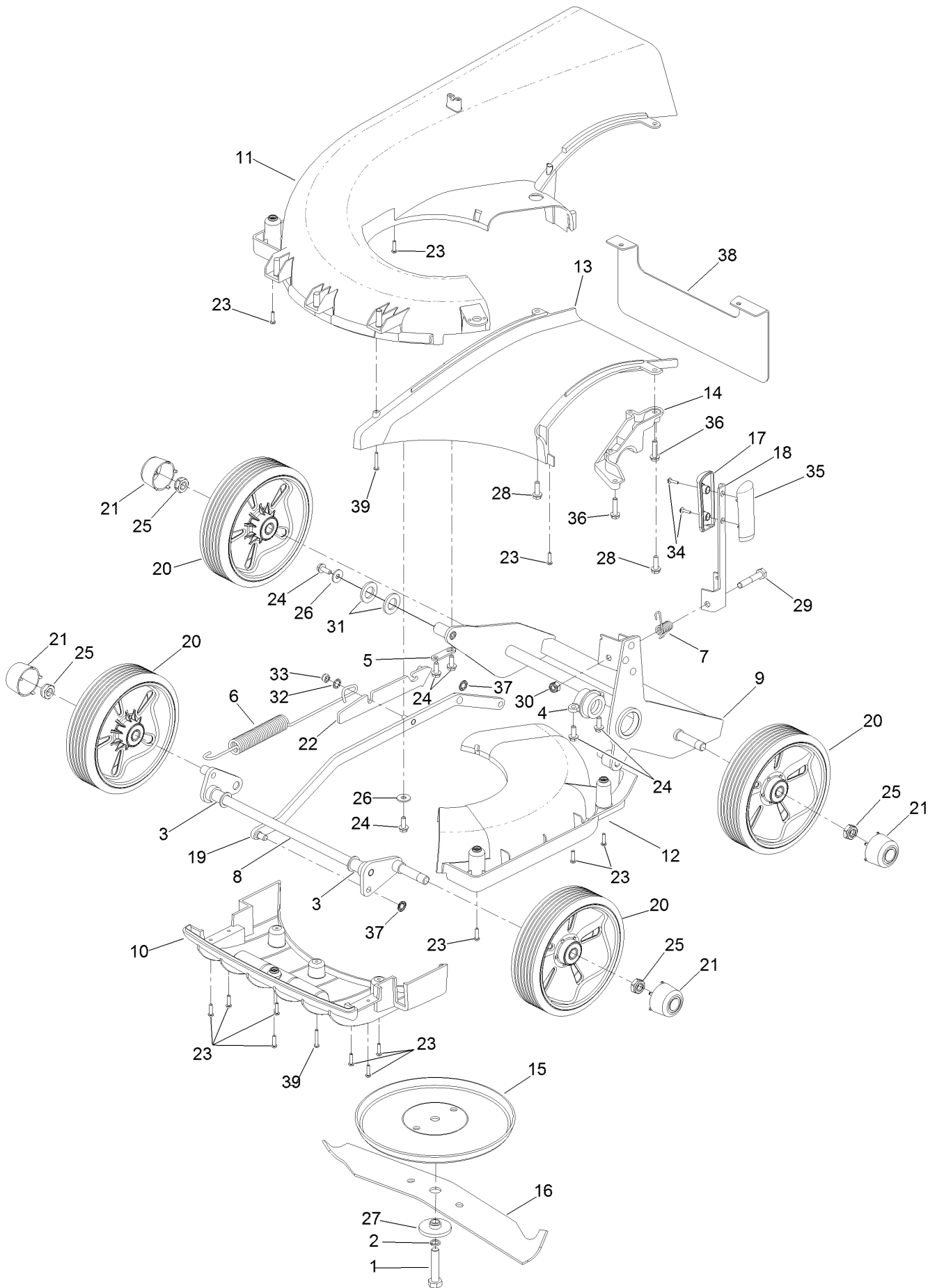

## Deck, Wheel and Blade Assembly (continued)

<i>Ref.</i>	<i>Part Number</i>	<i>Qty.</i>	<i>Description</i>	<i>Ref.</i>	<i>Part Number</i>	<i>Qty.</i>	<i>Description</i>
1	09788	1	Bolt-Unf	20	111-4036	4	Wheel ASM
2	09273	1	Washer-Spring	21	111-0066	4	Cap-Wheel, Center
3	410069	2	Bearing-Axle, Front	22	111-0073	1	Mount-Spring
4	410048	1	Housing-Pivot Bearing, LH	23	111-0094	13	Screw
5	219037	1	Plate-Securing	24	09365	6	Screw-Taptite
6	410050	1	Spring-Counter Balance	25	111-0119	4	Nut-Nyloc
7	111-0078	1	Spring-HOC	26	09262	2	Washer
8	111-0027	1	Axle-Front	27	HY4014	1	Spacer-Distance, Cutterbar
9	111-0068-03	1	Frame-Wheel	28	09575	2	Screw-Taptite
10	111-0034	1	Moulding-Fin	29	ZBH1H050U	1	Bolt
11	111-0037	1	Moulding-Snail Deck	30	09441	1	Nut-Hex, NI
12	111-0038	1	Moulding-Access, Snail Deck	31	09491	2	Washer-Plain
13	111-0039	1	Moulding-Throw Plate	32	09472	1	Washer-Plain
14	111-0050	1	Mount-Bearing	33	09438	1	Nut-Nyloc
15	410057W	1	Disc-Friction	34	HY100078	2	Screw
16	111-0093	1	Cutterbar	35	111-0105	1	Knob-HOC, LH
17	111-0055	1	Knob-HOC, RH	36	09364	2	Screw-HH
18	111-0059	1	Lever-HOC	37	0201086	2	Washer-Starlock
19	111-0063	1	Rod-Connecting Bar	38	111-4952-03	1	Guard-Rear
				39	111-0100	2	Screw



**Count on it.**