



MODEL NO. 03422TE—70001 & UP

MODEL NO. 03427TE—70001 & UP

**OPERATOR'S
MANUAL**

REELMASTER® 2300-D/2600-D
Traction Unit



This operator's manual has instructions on safety, operation, and maintenance.

This manual emphasizes safety, mechanical and general product information. DANGER, WARNING and CAUTION identify safety messages. Whenever the triangular safety alert symbol appears, understand the safety message that follows. "IMPORTANT" highlights special mechanical information and "NOTE" emphasizes general product information worthy of special attention.

IDENTIFICATION AND ORDERING

MODEL AND SERIAL NUMBER

The model and serial number for the traction unit is on a plate that is mounted on the left front frame member. The model and serial number for the cutting unit is on a plate that is mounted on the top front of the center cutting unit. Use model and serial number in all correspondence and when ordering parts.

To order replacement parts from an authorized TORO Distributor, supply the following information:

1. Model and serial numbers of the machine.
2. Part number, description and quantity of parts desired.

NOTE: Do not order by reference number if a parts catalog is being used; use the part number.

Table of Contents

	Page
Safety	3
Specifications	9
Before Operating	10
Controls	13
First-Time Operation	16
Operating	20
Maintenance	23

Safety

Training

1. Read the instructions carefully. Be familiar with the controls and the proper use of the equipment.
2. Never allow children or people unfamiliar with these instructions to use the lawn mower. Local regulations may restrict the age of the operator.
3. Never mow while people, especially children, or pets are nearby.
4. Keep in mind that the operator or user is responsible for accidents or hazards occurring to other people or their property.
5. Do not carry passengers.
6. All drivers should seek and obtain professional and practical instruction. Such instruction should emphasize:
 - the need for care and concentration when working with ride-on machines;
 - control of a ride-on machine sliding on a slope will not be regained by the application of the brake. The main reasons for loss of control are:
 - insufficient wheel grip;
 - being driven too fast;
 - inadequate braking;
 - the type of machine is unsuitable for its task;
 - lack of awareness of the effects of ground conditions, especially slopes;
 - incorrect hitching and load distribution.

Preparation

1. While mowing, always wear substantial footwear and long trousers. Do not operate the equipment when barefoot or wearing open sandals.
2. Thoroughly inspect the area where the equipment is to be used and remove all objects which may be thrown by the machine.

3. **WARNING—Petrol is highly flammable.**

- Store fuel in containers specifically designed for this purpose.
- Refuel outdoors only and do not smoke while refueling.
- Add fuel before starting the engine. Never remove the cap of the fuel tank or add petrol while the engine is running or when the engine is hot.
- If petrol is spilled, do not attempt to start the engine but move the machine away from the area of spillage and avoid creating any source of ignition until petrol vapors have dissipated.
- Replace all fuel tanks and container caps securely.

4. Replace faulty silencers.

Operation

1. Do not operate the engine in a confined space where dangerous carbon monoxide fumes can collect.
2. Mow only in daylight or in good artificial light.
3. Before attempting to start the engine, disengage all blade attachment clutches and shift into neutral.
4. Do not use on slopes of more than:
 - Never mow side hills over 5°
 - Never mow uphill over 10°
 - Never mow downhill over 15°
5. Remember there is no such thing as a “safe” slope. Travel on grass slopes requires particular care. To guard against overturning:
 - do not stop or start suddenly when going up or downhill;
 - engage the clutch slowly, and always keep the machine in gear, especially when traveling downhill;

- machine speeds should be kept low on slopes and during tight turns;
 - stay alert for bumps and hollows and other hidden hazards;
 - never mow across the face of the slope, unless the lawn mower is designed for this purpose.
6. Use care when pulling loads or using heavy equipment.
 - Use only approved drawbar hitch points.
 - Limit loads to those you can safely control.
 - Do not turn sharply. Use care when reversing.
 - Use counterweight(s) or wheel weights when suggested in the instruction handbook.
 7. Watch out for traffic when crossing or near roadways.
 8. Stop the blades rotating before crossing surfaces other than grass.
 9. When using any attachments, never direct discharge of material toward bystanders nor allow anyone near the machine while in operation .
 10. Never operate the lawn mower with defective guards, shields or without safety protective devices in place.
 11. Do not change the engine governor settings or overspeed the engine. Operating the engine at excessive speeds may increase the hazard of personal injury.
 12. Before leaving the operator's position:
 - disengage the power take-off and lower the attachments;
 - change into neutral and set the parking brake;
 - stop the engine and remove the key.
 13. Disengage the drive to attachments when transporting or not in use.
 14. Stop the engine and disengage the drive to the attachment
 - before refueling;
 - before removing the grass catcher;
 - before making height adjustments unless the adjustment can be made from the operator's position.
 - before clearing blockages;
 - before checking, cleaning or working on the lawnmower;
 - after striking a foreign object. Inspect the lawnmower for damage and make repairs before restarting and operating the equipment.
 15. Reduce the throttle setting during engine runout and, if the engine is provided with a shutoff valve, turn the fuel off at the conclusion of mowing.

Maintenance and Storage

1. Keep all nuts, bolts and screws tight to be sure the equipment is in safe working condition.
2. Never store the equipment with petrol in the tank inside a building where fumes may reach an open flame or spark.
3. Allow the engine to cool before storing in any enclosure.
4. To reduce the fire hazard, keep the engine, silencer, battery compartment and petrol storage area free of grass, leaves, or excessive grease.
5. Check the grass catcher frequently for wear or deterioration.
6. Replace worn or damaged parts for safety.
7. If the fuel tank has to be drained, this should be done outdoors.
8. Be careful during adjustment of the machine to prevent entrapment of the fingers between moving blades and fixed parts of the machine.
9. On multi-bladed machines, take care as rotating one blade can cause other blades to rotate.

10. When the machine is to be parked, stored or left unattended, lower the cutting means unless a positive mechanical lock is used.

Sound & Vibration Levels

Sound Levels

This unit has an equivalent continuous A-weighted sound pressure at the operator ear of: 84 dB(A), based on measurements of identical machines per 84/538/EEC.









This unit has a sound power level of 98 dB(A)/1pW, based on measurements of identical machines per procedures outlined in Directive 79/113/EEC and amendments.









Vibration Levels





This unit has a vibration level of 5.0 m/s² at the posterior, based on measurements of identical machines per ISO 5349 procedures.





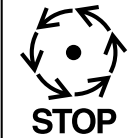
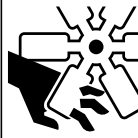

This unit does not exceed a vibration level of 0.5 m/s² at the posterior based on measurements of identical machines per ISO 5349 procedures.



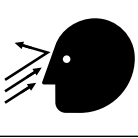
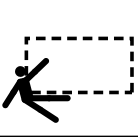

Symbol Glossary



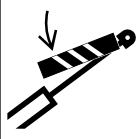
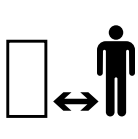
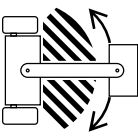
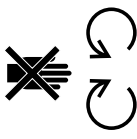

							
Caustic liquids, chemical burns to fingers or hand	Poisonous fumes or toxic gases, asphyxiation	Electrical shock, electrocution	High pressure fluid, injection into body	High pressure spray, erosion of flesh	High pressure spray, erosion of flesh	Crushing of fingers or hand, force applied from above	Crushing of toes or foot, force applied from above

							
Crushing of whole body, force applied from above	Crushing of torso, force applied from side	Crushing of fingers or hand, force applied from side	Crushing of leg, force applied from side	Crushing of whole body	Crushing of head, torso and arms	Cutting of fingers or hand	Cutting of foot

						
Cutting or entanglement of foot, rotating auger	Severing of foot, rotating knives	Severing of fingers or hand, impeller blade	Wait until all machine components have completely stopped before touching them	Severing of fingers or hand, engine fan	Whole body entanglement, implement input drive line	Fingers or hand entanglement, chain drive

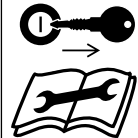
							
Hand & arm entanglement, belt drive	Thrown or flying objects, whole body exposure	Thrown or flying objects, face exposure	Runover/backover, (relevant machine to appear in dashed box)	Machine tipping, riding mower	Machine rollover, ROPS (relevant machine to appear in dashed box)	Stored energy hazard, kickback or upward motion	Hot surfaces, burns to fingers or hands

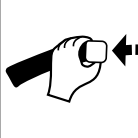
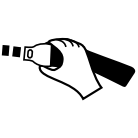
							
Explosion	Fire or open flame	Secure lifting cylinder with locking device before getting in hazardous area	Stay a safe distance from the machine	Stay clear of articulation area while engine is running	Do not open or remove safety shields while engine is running	Do not step on loading platform if PTO is connected to tractor & engine is running	Do not step

						
Shut off engine & remove key before performing maintenance or repair work	Riding on this machine is allowed only on a passenger seat & only if the driver's view is not hindered	Consult technical manual for proper service procedures	Fasten seat belts	Safety alert triangle	outline safety alert symbol	Read operator's manual

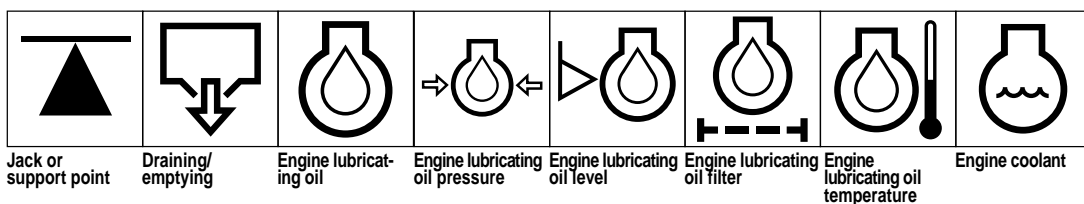
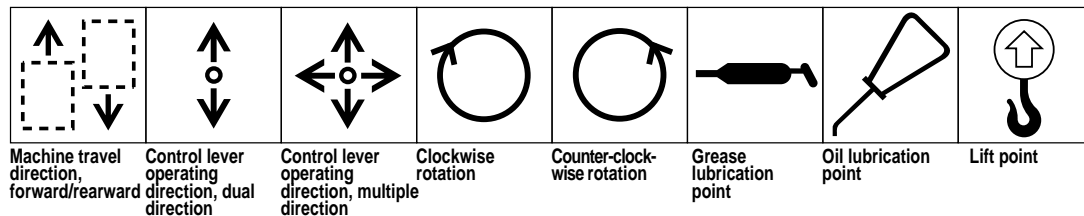
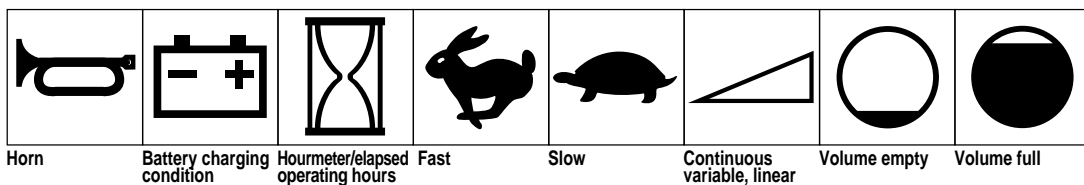
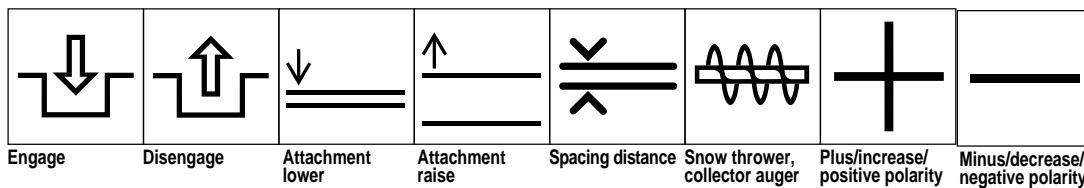
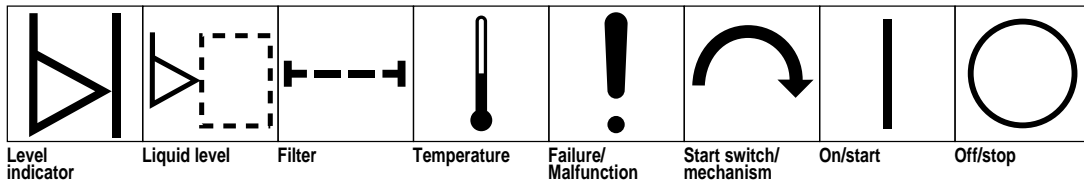
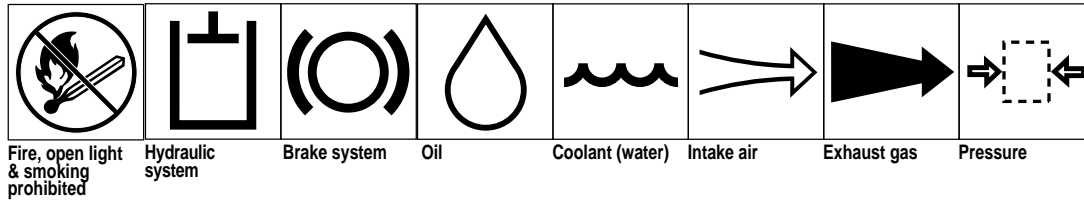

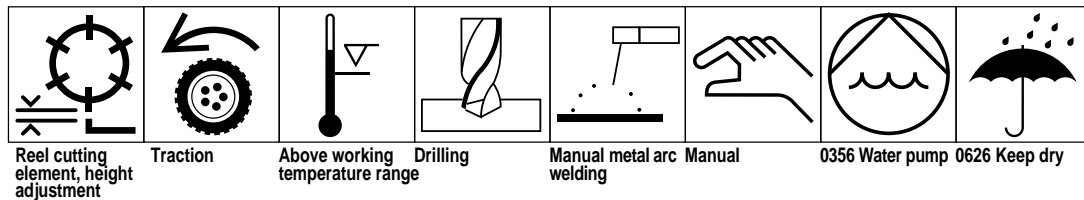
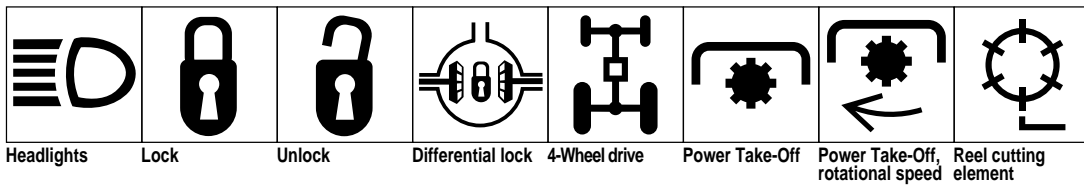
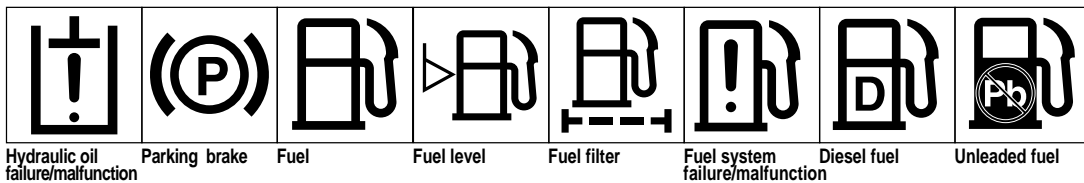
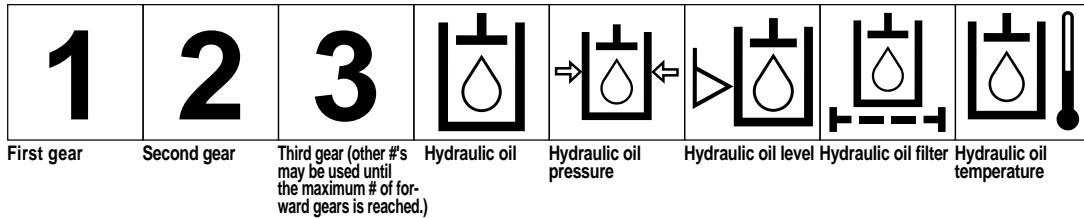
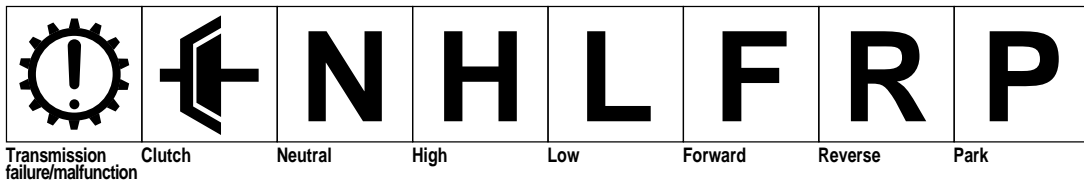
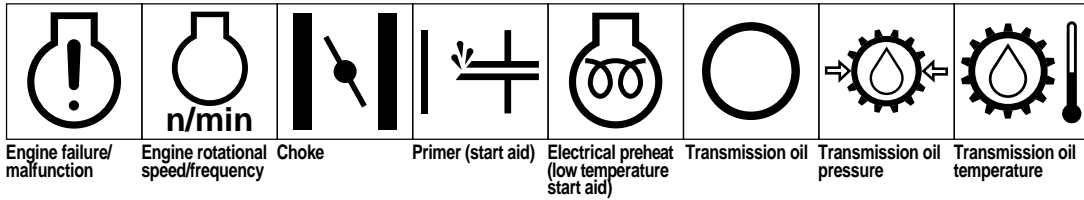
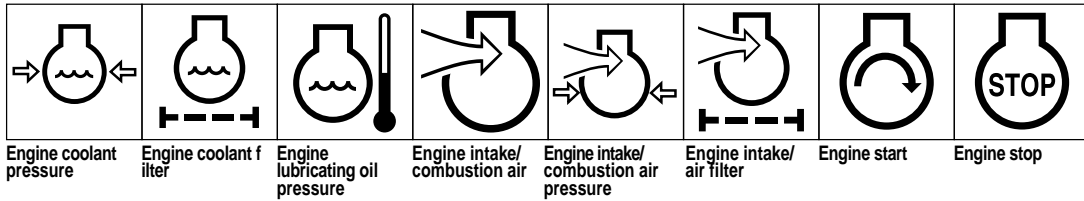

Specifications

Engine: Perkins, 4-cycle, 3-cylinder, liquid-cooled, vertical overhead valve, diesel engine with centrifugal water pump. 13.4 kW governed to a maximum speed of 3200 rpm. 676 cc displacement. Forced lubrication gear pump. Mechanical centrifugal governor. Mechanical fuel transfer pump. Fuel filter/water separator with replaceable filter element. 12-volt (0.7 kW) starter. Heavy-duty remote mounted air cleaner. Spin-on oil filter.

Radiator: Side-mounted radiator. Cooling system capacity is 4.7 liters.

Electrical: 12-volt Group 55, 450 cold-cranking amps at -18° , 75-minute reserve capacity at 27°C . 14-amp alternator with regulator/rectifier. Seat switch, PTO and traction interlock switches. Indicator light when cutting units are running.

Fuel Capacity: 24.6 liters

Traction Drive: Three high-torque hydraulic wheel motors. 3-wheel drive; two-position selector valve located below the seat, push for 3-wheel drive and pull for 2-wheel drive. Oil cooler and shuttle valve provide positive closed-loop cooling.

Hydraulic Oil Capacity/Filter: Remote mounted, 8.7 liter oil reservoir. 25-micron remote-mounted spin-on the filter.

Ground Speed: Infinitely variable speed selection in forward and reverse

Mowing speed:	0–8 km/h
Transport speed:	0–13 km/h
Reverse speed:	0–3 km/h

Tires/Wheels: Two front traction tires, 20 x 10-8, tubeless, 4-ply rating. Rear steering tire and tube: 20 x 8-8, 2-ply rating. Demountable front rims. Recommended tire pressure 97–138 kPa front tires and 55–69 kPa rear tire.

Frame: The frame consists of formed steel, welded steel and steel tubing components. Tricycle vehicle with 3-wheel traction drive and rear wheel steering.

Steering: Pinion and sector gear with solid drag link to rear steer wheel arm.

Brakes: Service braking through the dynamic charac-

teristics of the hydrostat. Parking or emergency brake is actuated by a ratchet hand lever on the operator's left-hand side.

Controls: Foot-operated traction pedal and traction pedal stop. Hand-operated throttle, ignition switch, reel engagement switch, cold start button reel unit lift lever, parking brake and seat adjustment, 2-position selector valve for 2- or 3-wheel drive selection.

Gauges and Protective Systems: Hour meter, temperature gauge, 4-light warning cluster gauge: oil pressure, water temperature amps and glow plug. High water temperature shutdown. Electric traction pump declutching switch for cold start. Engine preheat incorporated into the ignition switch.

Seat: Adjustable to operator weight, fore and aft, with removable fold-up armrests.

Cutting Unit Lift: Hydraulic lift with an automatic reel shut off.

Overall Dimensions:

Wheel tread width:	138
cm	
Wheel base:	140
cm	
Width:	194
cm	
Length:	249
cm	
Height:	112
cm	
Weight:	562 kg with 5-blade cutting
unit	
	569 kg with 8-blade cutting
unit	

Before Operating

CAUTION

Before servicing or making adjustments to the machine, stop the engine and remove the key from the switch.

Check The Crankcase Oil (Fig 1 & 2)

The engine is shipped with oil in the crankcase; however, you must check the oil level before and after you first start the engine.

1. Position the machine on a level surface.
2. Remove the dipstick and wipe it with a clean cloth. Push the dipstick down into the dipstick tube and make sure it is seated fully. Pull out the dipstick and check the oil level.
3. If the oil level is low, remove the oil fill cap (Fig 2) and gradually add small quantities of oil, checking the level frequently, until the level reaches the FULL mark on the dipstick.
4. The engine uses any high-quality 10W30 detergent oil having the American Petroleum Institute—API—service classification CD.

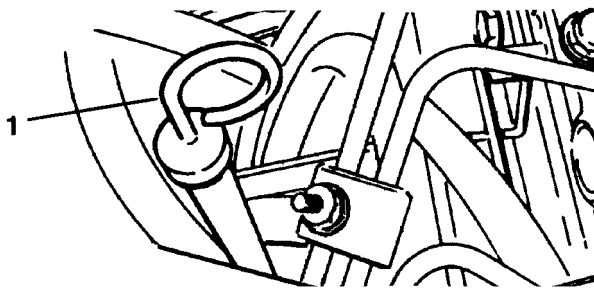

Figure 1

1. Dipstick

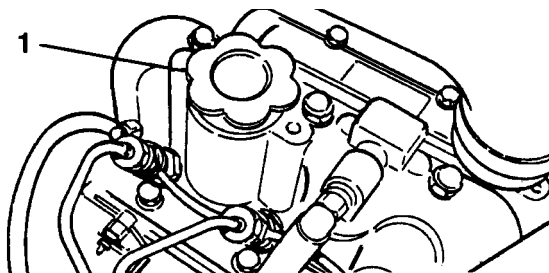

Figure 2

1. Oil fill cap

IMPORTANT Check the oil level every 5 operating hours or daily. Change the oil after every 50 hours of operation.

Fill The Fuel Tank

The engine runs on No. 2 diesel fuel. Fuel tank capacity is 24.6 liters.

DANGER

Because diesel fuel is flammable, use caution when storing or handling it.

- Do not smoke while filling the fuel tank.
- Do not fill the fuel tank while the engine is running, hot, or when the machine is in an enclosed area.
- Always fill the fuel tank outside and wipe up any spilled diesel fuel before starting the engine.
- Store fuel in a clean, safety-approved container and keep the cap in place. Use diesel fuel for the engine only; not for any other purpose.

1. Clean the area around the fuel tank cap.
2. Remove the fuel tank cap.

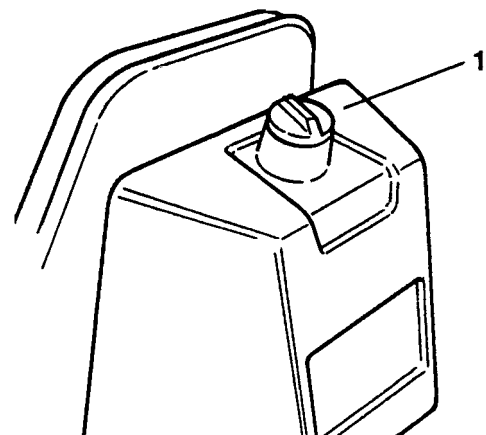

Figure 3

1. Fuel tank cap

3. Fill the tank to about 2.5 cm below the top of the tank (bottom of the filler neck). **DO NOT OVERFILL.** Then install the cap.

- To prevent a fire hazard, wipe up any fuel that may have spilled.

Check the Cooling System

Clean debris off the radiator screen, radiator and oil cooler daily (Fig. 4), or hourly if conditions are extremely dusty and dirt.

The cooling system is filled with a 50/50 solution of water and permanent ethylene glycol anti-freeze. Check the level of coolant at the beginning of each day before you start the engine. Capacity of the cooling system is 5.0 liters.

WARNING

If the engine has been running, pressurized hot coolant can escape when the radiator cap is removed and cause burns.

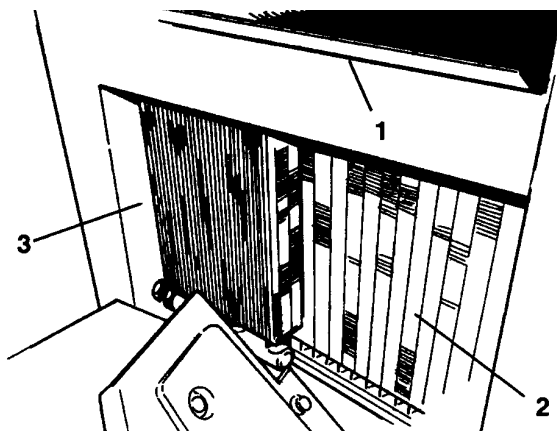

Figure 4

- Radiator screen
- Radiator
- Oil cooler

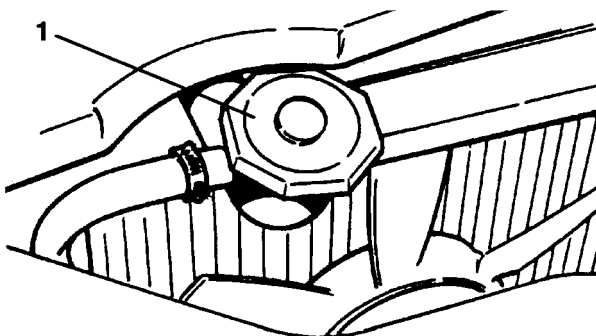

Figure 5

- Radiator cap

- Carefully remove the cap from the radiator.
- Check the level of coolant in the radiator. The radiator should be filled to the top of the filler neck.
- If the coolant level is low, replenish the system. **DO NOT OVERFILL.**
- Install the radiator cap.

Check The Hydraulic System Fluid

The hydraulic system is designed to operate on anti-wear hydraulic fluid. The machine's system is filled at the factory with approximately 12.5 liters of fluid. However, check the level of hydraulic fluid before you first start the engine and daily thereafter.

Group 1—Hydraulic Fluid (Recommended for ambient temperatures consistently below 37° C.)

ISO-type 46/68 anti-wear hydraulic fluid

Mobil	Mobil Fluid 424
Shell	Donax TD
Amoco	Amoco 1000
Conoco	Power Tran 3
International Harvester	Hy-Tran
Texaco	TDH
Exxon	Torque Fluid
Kendall	Hyken 052
BP Oil	BP HYD TF
Boron Oil	Eldoran UTH
Phillips	HG Fluid
Union Oil	Hydraulic/Tractor
Fluid	
Chevron	Tractor Hydraulic
Fluid	

Note: All are interchangeable. **Group 2—Hydraulic Fluid (Biodegradable):**

ISO VG 32/46 anti-wear hydraulic fluid

Mobil	EAL 224 H
-------	-----------

IMPORTANT: Due to the nature of biodegradable fluids, it is critical that the fluid be changed at the recommended intervals or severe hydraulic component damage may occur.

Note: The fluid in Group 2 is not compatible with the

fluids in Group 1.

IMPORTANT: These hydraulic fluids are specified to allow optimal operation of the machine in a wide range of temperatures. The group 1 fluids are multi-viscosity hydraulic fluids that allow operation at lower temperatures without the increased viscosity associated with straight viscosity fluids.

Note: When changing from one type of hydraulic fluid to the other, be certain you remove all the old fluid from the system because some brands of one type are not completely compatible with some brands of the other type of hydraulic fluid.

IMPORTANT: Use only the types of hydraulic fluids specified. Other fluids could cause system damage.

Note: A red dye additive for the hydraulic system oil is available in 20 ml bottles. One bottle is sufficient for 15–23 liters of hydraulic oil. Order Part No. 44-2500 from your authorized Toro distributor.

1. Position the machine on a level surface.
2. Make sure the machine has been operated so the oil is warm. Check the oil level by looking in the sight gauge. If the oil level is at the center of the gauge, it is sufficient.
3. If the oil level is not at the center of the gauge, remove the cap from the hydraulic oil reservoir and slowly fill the reservoir with Mobil 424 or equivalent hydraulic oil until the level reaches the center of the sight gauge. **DO NOT OVERFILL.**

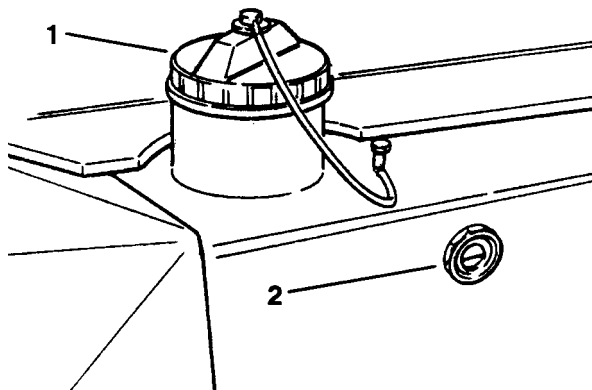

Figure 6

1. Hydraulic reservoir cap
2. Sight Gauge

IMPORTANT To prevent system contamination, clean the top of the hydraulic oil containers before puncturing. Make sure the pour spout and funnel are clean.

4. Install the reservoir cap. Wipe up any oil that may have spilled.

Inspect the Fuel Filter

Inspect the fuel filter bowl daily for water or other contaminants. If water or other contaminants are present, they must be removed before operation.

1. Close the fuel shut-off above the filter.
2. Unscrew the nut securing the bowl to the filter head. Remove water or other contaminants from the bowl.
3. Inspect the fuel filter and replace it if it is dirty.
4. Install the bowl to the filter head. Make sure to position the O-ring correctly between the bowl mounting nut and the filter head.

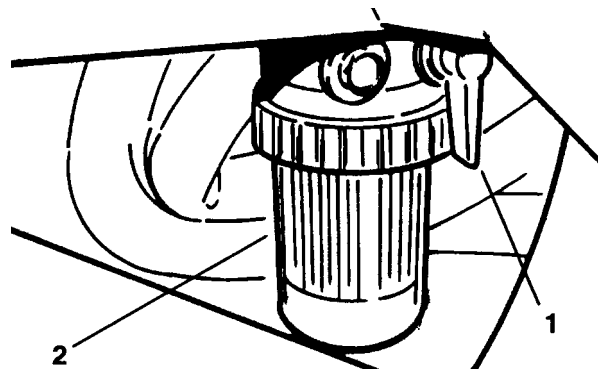

Figure 7

1. Fuel filter

5. Open the fuel shut-off above the filter to re-fill with fuel. Close the bleed screw.
6. Open the bleed screw on the filter mounting, allowing the bowl to re-fill with fuel. Close the bleed screw.

 **DANGER**

Because diesel fuel is flammable, use caution when storing or handling it.

- Do not smoke while filling the fuel tank.
- Do not fill the fuel tank while the engine is running, hot, or when the machine is in an enclosed area.
- Always fill the fuel tank outside and wipe up any spilled diesel fuel before starting the engine.
- Store fuel in a clean, safety-approved container and keep the cap in place. Use diesel fuel for the engine only; not for any other purpose.

Check Tire Pressure

The tires are over-inflated for shipping. Therefore, release some of the air to reduce the pressure. Correct air pressure in the front tires is 83–110 kPa and the rear tire is 55–68 kPa.

IMPORTANT: Maintain even pressure in all tires to assure a good quality of cut and proper machine performance. DO NOT UNDERINFLATE.

Check Reel-to-Bedknife Contact.

Each day before operating, check the reel-to-bedknife contact, regardless of whether quality of cut had previously been acceptable. There must be light contact across the full length of the reel and bedknife.

Check The Torque of the Wheel Nuts

 **WARNING**

Torque the wheel nuts to 61–88 Nm after 1–4 hours of operation and again after 10 hours of operation and every 200 hours thereafter. Failure to maintain proper torque could result in failure or loss of the wheel and may result in personal injury.

Controls

Traction and Stopping Pedal (Fig. 8, 9, & 10)—The traction pedal has three functions: one, to make the machine move forward; two, to move it backward; and three, to stop it. Using the heel and toe of your right foot, depress the top of the pedal to move forward and bottom of the pedal to move backward or to assist in stopping when moving forward. Also, move the pedal to the neutral position to stop the machine. For your comfort, do not rest the heel of your foot on reverse when operating forward.

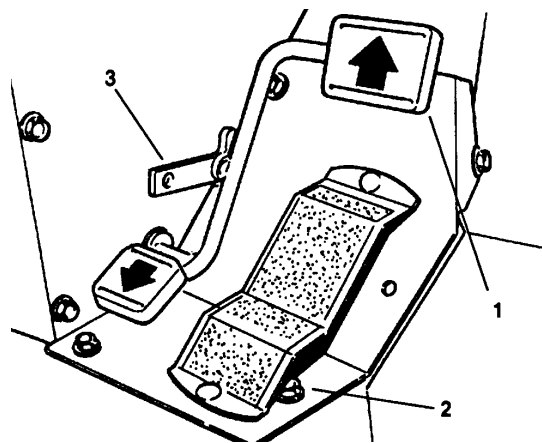

Figure 8

1. Traction pedal
2. Speed selector
3. Pedal stop

Speed Selector (Fig. 8)—The cam lever at the side of the traction pedal can be rotated to maintain the desired speed.

The reverse pedal stop (under the pedal) is set at the factory to provide 4.8 kmh (3 mph) maximum speed in reverse.

Ignition Switch—The ignition switch, which is used to start, stop and preheat the engine, has four positions: OFF, ON, START and GLOW PLUGS (PRE-HEAT).

To start the engine, turn the key counterclockwise—GLOW PLUG position—and hold it there for 20 to 30 seconds, then, turn the key clockwise to the START position to engage the starter motor. Release the key when the engine starts. The key will move automatically to ON. To shut off the engine, turn the key counterclockwise to OFF. Remove the key from the switch and install the switch cover to prevent accidental starting.

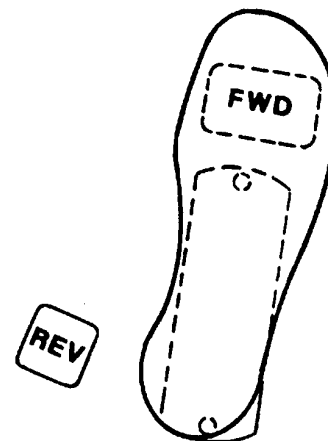

Figure 9

Throttle (Figure 11)—Moving the throttle upward increases engine speed; downward decreases engine speed.

Cutting Unit Lift Lever (Figures 11)—The lift lever has three positions: LOWER, RAISE, and NEUTRAL. To lower the cutting units to the ground, move the lift lever forward.

When lowering the cutting units, make sure the hydraulic cylinder is completely retracted before releasing the lift lever. The cutting units won't operate unless the cylinder is retracted.

To raise the cutting units, pull the lift lever rearward to the RAISE position.

Cutting Unit Drive Switch (Figures 11) —The switch has two positions: ENGAGE and DISENGAGE. An amber light on the dash indicates when the reels are turning. Pull the switch lever out to move from disengage to engage.

Hour Meter (Figures 11)—Indicates the total hours of machine operation. The hour meter starts whenever the key switch is turned to "ON."

Temperature Gauge (Fig. 10)—Registers coolant temperature in the system.

Oil Pressure Light (Fig. 10)—Glow if the engine oil pressure drops below a safe level.

Water Temperature Light (Figure 10)—This light glows and the engine automatically shuts-down if the

engine coolant temperature gets too high.

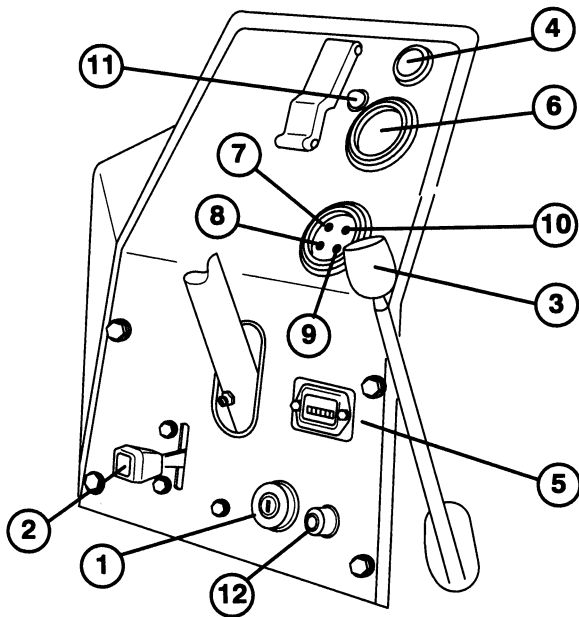

Figure 10

1. Starter switch & cover
2. Throttle
3. Cutting unit lift lever
4. Cutting unit drive switch
5. Hour meter
6. Water temperature gauge
7. Oil pressure light
8. Amp gauge
9. Glow plug indicator
10. High water temperature shut-down light
11. Reel operating light
12. Cold-start button

Amp Light (Fig. 10)—The amp light should be off when the engine is running. If it is on, the charging system should be checked and repaired as necessary.

Glow Plug Indicator (Fig. 10)—This indicator light will glow when the glow plugs are operating.

Cold Start Button (Fig. 10)—When starting a cold engine, press the cold start button to electrically de-clutch the traction pump. When the engine starts, release the button.

Parking Brake—Whenever the engine is shut off, the parking brake must be engaged to prevent accidental movement of the machine. To engage the parking brake, pull back on the lever.

Drive Engagement Control (Fig 11)—Located on the lower left side of the operator. Pull the knob out for 2-wheel drive; push the knob in for 3-wheel drive.

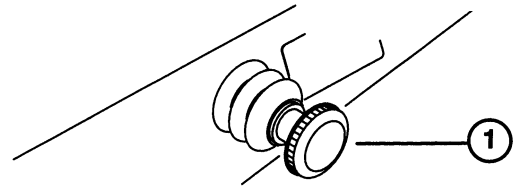

Figure 11

1. Deck engagement control Pull out—Two-wheel drive
Push in—Three-wheel drive

Reel Speed Control (Fig. 12)—For the desired reel speed, turn the reel speed control knob to the appropriate setting for height-of-cut setting and mower speed. Refer to *Selecting the Clip Rate* section of this manual.

Backlap Control (Fig. 12)—Turn the knob clockwise for backlapping and counterclockwise for mowing

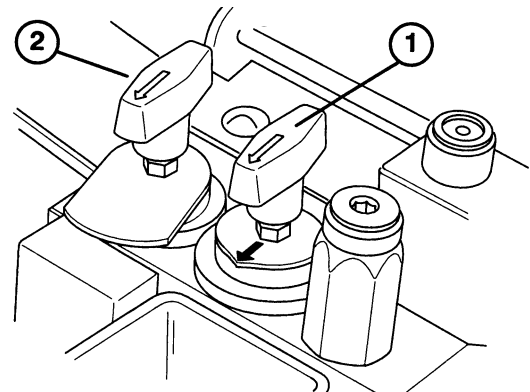

Fig. 12

1. Reel speed control
2. Backlap control

Seat Adjustments (Fig. 13)

Fore and Aft Adjustment—Move the lever on the side of the seat outward, slide the seat to the desired position and release the lever to lock the seat into position.

Deluxe Seat Adjustments (Fig. 13)

Weight Adjustment—Push the lever up or down to adjust to the operator's weight. Lever up—light operator, lever in middle position—medium weight operator or lever down for heavy operator.

Inclining Backrest—Turn the handle to adjust the backrest angle. (Deluxe Seat only).

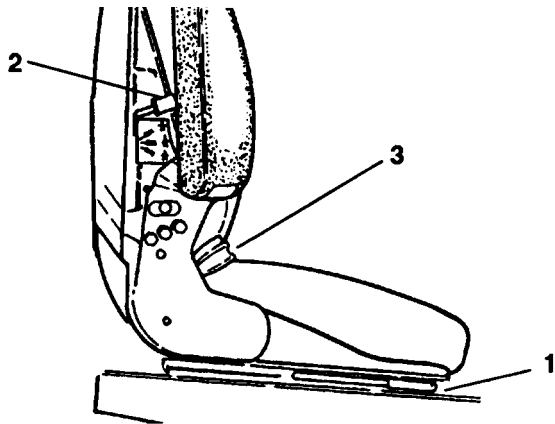

Figure 13

- 1. Fore and aft lever
 - 2. Weight adjustment lever
 - 3. Inclining backrest
-

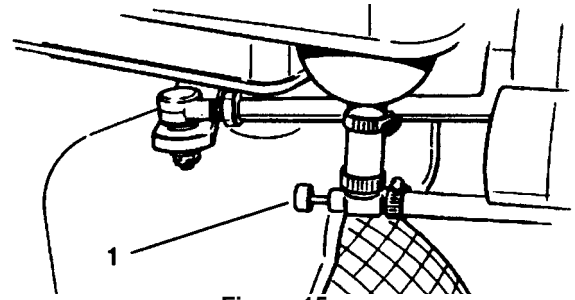

Figure 15

- 1. Fuel shut off (on the fuel filter)
-

Fuel Shut-off Valves, (Fig. 14 & 15)—Close the fuel shutoff valves under the fuel tank and on the fuel filter when storing the machine.

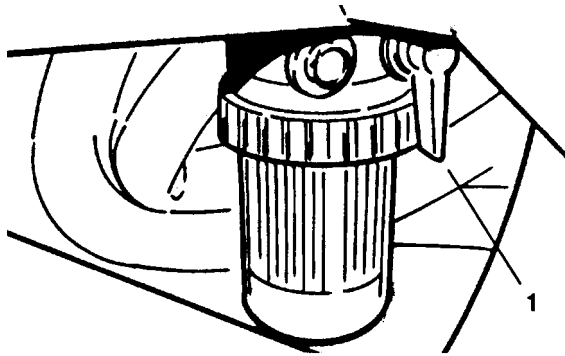

Figure 14

- 1. Fuel shut off (under the fuel tank)
-

Operating Instructions

Starting/Stopping The Engine

IMPORTANT: The fuel system may have to be bled if any of the following situations have occurred:

- Initial start up of a new engine.
- The engine has ceased running due to lack of fuel.
- Maintenance has been done on fuel system components; i.e., the filter replaced, etc.

Refer to *Bleeding The fuel System*

1. Be sure the parking brake is set and the reel drive switch is in DISENGAGE.
2. Remove your foot from the traction pedal and make sure the pedal is in the neutral position.
3. Move the throttle lever to the full throttle position.
4. Remove the cover from the ignition switch. Insert the key and turn it counterclockwise to the GLOW PLUG position—and hold it there for approximately 20 to 30 seconds. Then, turn the key clockwise to START to engage the starter motor. Release the key when the engine starts. The key will move automatically to ON.

IMPORTANT To prevent overheating the starter motor, do not engage the starter longer than 10 seconds. After 10 seconds of continuous cranking, wait 60 seconds before engaging the starter motor again.

5. For cold-weather starting, press the cold-start button to declutch the electric traction pump. When the engine starts, release the button.
6. When starting the engine for the first time, or after an engine overhaul, operate the machine in forward and reverse for one to two minutes. Also operate the lift lever and the reel drive switch to

be sure all parts operate correctly.

Turn the steering wheel to the left and right to check steering response. Then shut the engine off and check for oil leaks, loose parts and any other noticeable malfunctions.



CAUTION

Shut off the engine and wait for all moving parts to stop before checking for oil leaks, loose parts and other malfunctions.

7. To stop the engine, move the throttle control downward to IDLE, move the reel drive switch to DISENGAGE and turn the ignition key to OFF. Remove the key from the switch and install the switch cover to prevent accidental starting.
8. Close the fuel shut-off valves before storing the machine.

Bleeding The Fuel System

1. Park the machine on a level surface. Make sure the fuel tank is at least half full.



DANGER

Because diesel fuel is flammable, use caution when storing or handling it.

- Do not smoke while filling the fuel tank.
- Do not fill the fuel tank while the engine is running, hot, or when the machine is in an enclosed area.
- Always fill the fuel tank outside and wipe up any spilled diesel fuel before starting the engine.
- Store fuel in a clean, safety-approved container and keep the cap in place. Use diesel fuel for the engine only; not for any other purpose.

2. Unlatch and raise the hood.

3. Open the fuel shut-off valve under the fuel tank and on the fuel filter.
4. Open the (2) bleed screws on the side of the fuel filter mounting head, allowing the bowl to re-fill with fuel. Close bleed screws when the bowl is filled.

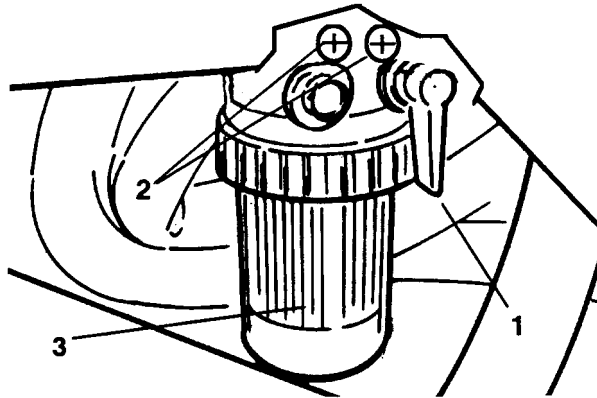

Figure 16

1. Fuel shutoff
2. Bleed screws (2)
3. Bowl

5. On the left side of the engine (below the alternator) find the transfer pump inlet screw. Note the angle of the fitting on the transfer pump inlet and loosen the screw (left screw only).
6. When a steady stream of fuel flows out of the transfer pump screw, tighten the screw, retaining the angle of fitting before it was loosened.
7. Loosen the injection pump inlet screw on the right side of the engine.
8. Pump the priming lever until a steady stream of fuel flows out of the injection pump inlet screw, then tighten the screw.

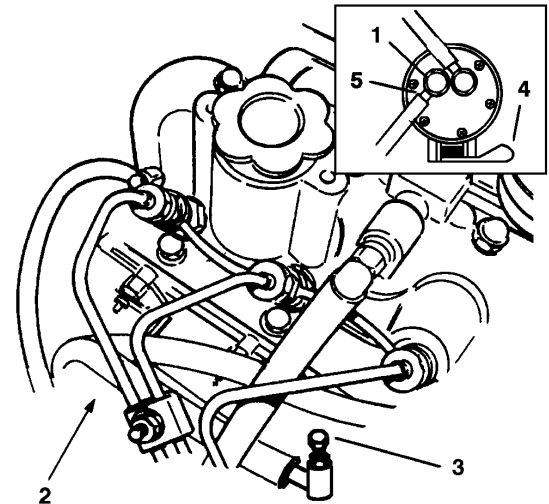

Figure 17

1. Transfer pump screw
2. Injection pump Inlet screw location
3. Injection pump inlet screw
4. Priming lever
5. Note fitting angle

Check The Interlock Switch Operation

CAUTION

Do not disconnect the safety switches because they are for the operator's protection. Check the safety switch operation daily to be sure the system operates correctly. If a switch is not operating correctly, replace it before operating the machine. Replace the switches every two years to be sure of maximum safety.

1. Be sure the parking brake is set and all bystanders are away from the area of operation. Keep your hands and feet away from the cutting units.
2. With the operator off the seat, the backlap knob turned counterclockwise, the traction pedal in neutral and the reel switch in the OFF position, the engine should start. If either the traction pedal is depressed or the reel switch is turned ON with the operator off the seat, the engine should stop. Correct the problem if the safety switches are not operating correctly.
3. With the engine running, the operator off the seat and the backlap knob turned clockwise, the engine should not stop when the reel switch is turned ON. Correct the problem if the safety

switches are not operating correctly.

4. With the operator on the seat, the engine running, and the reel switch in the ON position, the dash indicator light should be glowing and the reel motors turning when the lift cylinder is fully retracted. As the lift cylinder is extended, the light should go out and the reel motors should stop turning. Correct the problem if the system is not operating correctly.
5. With the operator on the seat, the engine must not start with either reel switch engaged or the traction control engaged. Correct the problem if the system is not operating correctly.

Towing the Traction Unit

In case of emergency, the Reelmaster 2300-D can be towed for a short distance. However, Toro does not recommend this as a standard procedure.

IMPORTANT Do not tow the machine faster than 3–4.8 kmh because the drive system may be damaged. If the machine must be moved a considerable distance, transport it on a truck or trailer.

1. Turn the by-pass valve on pump 90°.

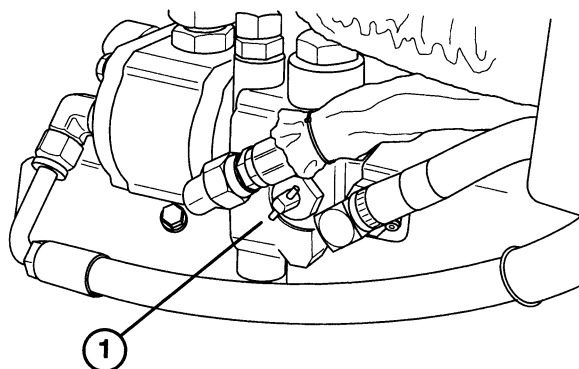

Figure 18

1. Hose plug

2. Before starting the engine, close the by-pass valve securely by rotating it 90°. Do not start the engine when the valve is open.

Operating Characteristics

Practice operating the Reelmaster and become thoroughly familiar with it. Because of its hydrostatic transmission and choices of either two or three wheel drive, its characteristics differ from many turf maintenance machines.

Points to consider when operating are the traction drive, engine speed and the load on the cutting units. Regulate the traction pedal to keep the engine rpm high and somewhat constant while mowing to maintain adequate power for the traction and cutting units. Adjust the speed selector to maintain constant ground speed and quality of cut. However, when on hilly terrain, do not use the speed selector.

Follow the operating guidelines in this manual and know how to operate the machine safely on all types of terrain. Never traverse or mow up and down on slopes over 20 degrees, nor traverse or mow side hills in excess of 15 degrees. Always plan well ahead to avoid the need for sudden stops, starts or turns. To stop, use the reverse pedal for braking. Before stopping the engine, disengage all controls, move the throttle to IDLE, and set the parking brake.

Selecting Clip Rate (Reel Speed)

To achieve a consistent, high-quality cut and a uniform after-cut appearance, the reel speed must be matched to the height of cut.

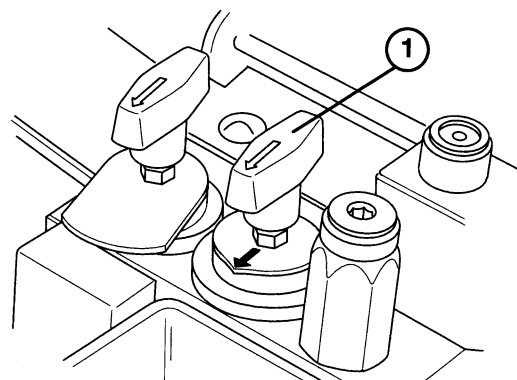

Figure 19

1. Reel speed control

Adjust the clip rate (reel speed) as follows:

1. Verify the height-of-cut setting on the cutting units. Using the column of the chart listing either 5- or 8-blade reels, find the height-of-cut listing nearest the actual height-of-cut setting. Look across the chart to find the number corresponding to that height of cut.
2. Turn the reel speed control knob to the number setting you found in step 1.
3. Operate the machine for several days, then exam-

ine the cut to ensure you are satisfied with the quality of cut. The reel speed knob may be set one position of either side of the position on the chart to account for differences in grass condition, grass length removed, and your personal preferences.

Training Period

Before mowing with the Reelmaster, The Toro Company suggests you find a clear area and practice starting and stopping, raising and lowering the cutting units, turning, etc. This training period will help the operator gain confidence in the performance of the Reelmaster.

Before Mowing

Inspect the area for debris and clear it if necessary. Determine the direction best to mow on the previous mowing direction. Always mow in an alternate pattern from the previous mowing, so that the grass blades will be less apt to lay down and therefore be difficult to gather between the reel blades and bedknife.

Transport Operation

Be sure the cutting units are in the fully up position, move the traction pedal stop from under the pedal to allow full traction pedal travel and place the throttle control FAST. While operating on slopes and uneven terrain, always reduce speed and use extreme caution before turning to reduce risk of tipping or losing control. Watch carefully for, and avoid, holes in the terrain, sudden drop-offs and other hidden hazards. To prevent costly damage and downtime, familiarize yourself with the width of the Reelmaster. Do not attempt to pass between immovable objects placed close together.

Inspection And Clean-Up After Mowing

After mowing, thoroughly wash the machine with a garden hose—without a nozzle so excessive water pressure will not cause contamination and damage to seals and bearings.

Selecting Reel Speed

Height of Cut (cm)	5-Blade Reel		8-Blade Reel	
	Reel Speeds		Reel Speeds	
	3-Wheel Drive 5–8 kmh	2-Wheel Drive 10–11 kmh	3-Wheel Drive 5–8 kmh	2-Wheel Drive 10–11 kmh
6.4	3	5		3
6.0	3	5		3
5.7	4	5		3
5.4	4	5		3
5.1	4	6		3
4.8	4	6	3	4
4.5	5	7	3	4
4.1	5	7	3	4
3.8	6		4	5
3.5	6		4	5
3.2	7		4	6
2.9	7		5	7
2.5	8		5	9
2.2	9		6	
1.9			7	
1.6			9	
1.3			9	
1.0			9	

Make sure the radiator screen, radiator and the oil cooler(diesel models) and cooling fins and area around the engine cooling air intake (gasoline models) are kept free of dirt or grass clippings. After cleaning, it is recommended

- the machine be inspected for possible hydraulic fluid leaks, damage or wear to the hydraulic and mechanical components
- the cutting units be checked for sharpness and correct reel-to-bedknife adjustment.

Maintenance

Minimum Recommended Maintenance Intervals

	Every 50 hours	Every 100 hours	Every 200 hours	Every 400 hours
<ul style="list-style-type: none"> Inspect the air filter, dust cap and burp valve Lube all grease fittings †Change engine oil †Check engine belt tension 				
<ul style="list-style-type: none"> †Change the engine oil filter †Check the traction belt's tension 				
<ul style="list-style-type: none"> Service the air filter Replace the fuel filter †Replace the hydraulic filter †Torque the wheel lug nuts 				
<ul style="list-style-type: none"> Replace hydraulic fluid Check battery level and connections Inspect the traction linkage movement ††Torque the head bolts and adjust the valves ††Check the engine RPM (idle and full throttle) 				
<ul style="list-style-type: none"> †Initial break in at 10 hours ††Initial break in at 50 hours 				
<ul style="list-style-type: none"> Replace moving hoses Replace safety switches Flush cooling the cooling system and replace hoses Replace the thermostat Drain and flush the fuel tank Drain and flush the hydraulic tank 				
			<p>Annual Recommendations: Items are recommended every 1000 hours or two years, whichever occurs first.</p>	

Quick Reference Aid

1. Engine oil level
2. Engine oil drain (17mm socket)
3. Hydraulic oil level—Center of sight glass
4. Belts (Fan/water pump, hydraulic pump)
5. Coolant level fill
6. Fuel—Diesel only
7. Grease points
8. Radiator screen
9. Air cleaner
10. Water separator/fuel filter
11. Battery
12. Tire pressure:
(.8–1.1 bar) front
(.6–.7 bar) rear
13. Fuses

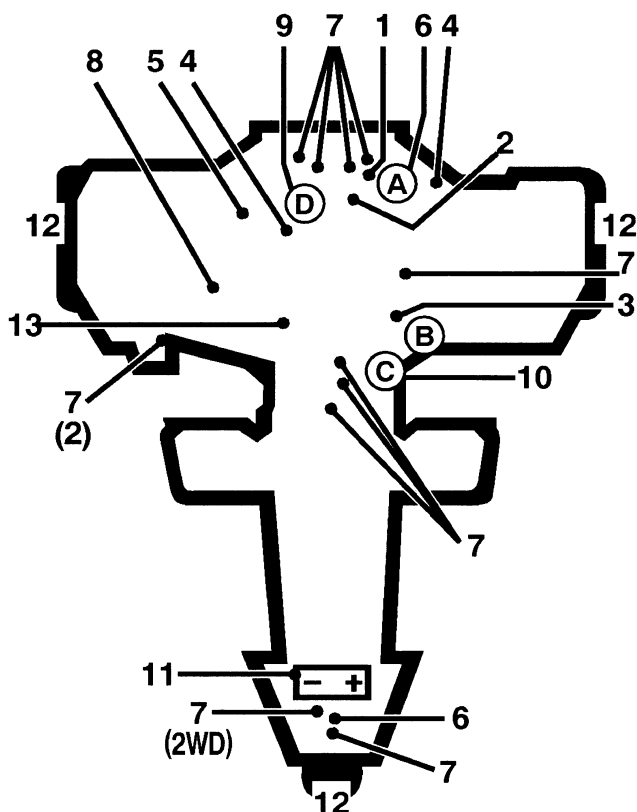

	Fluid Type	Capacity	Change Fluid	Change Filter	Filter Part No.
Engine oil	SAE 10W30 CD	3.0 l	50 hours	100 hours	85-4930
Hyd. circuit oil	Mobil 424	12.5 l	400 hours	200 hours	54-0110
Fuel filter				200 hours	Perkins 130366040
Air cleaner		Clean every 50 hours		200 hours	93-2195
Fuel	No. 2 Diesel	24.5 l			
Coolant	50/50 Ethylene glycol water	4.7 l			Drain and flush, 2 years

GREASING BEARINGS AND BUSHINGS (Fig. 20–26)

The traction unit and cutting unit's grease fittings must be lubricated regularly with No. 2 General Purpose Lithium Base Grease. If the machine is operated under normal conditions, lubricate bearings and bushings after every 50 hours of operation. Bearings and bushings must be lubricated daily when operating conditions are extremely dusty and dirty. Dusty and dirty operating conditions could cause dirt to get into the bearings and bushings, resulting in accelerated wear.

The traction unit bearings and bushings that must be lubricated are:

Steering column (Fig. 20), steering gears (2) (Under skirt below steering sector), steering shaft (2) (Fig. 21), lift arms (3) (Fig. 22), rear lift cylinder pivot (Fig. 24), traction pedal pivot (Fig. 25).

Also, apply grease to slots in cylinder support (Fig. 26).

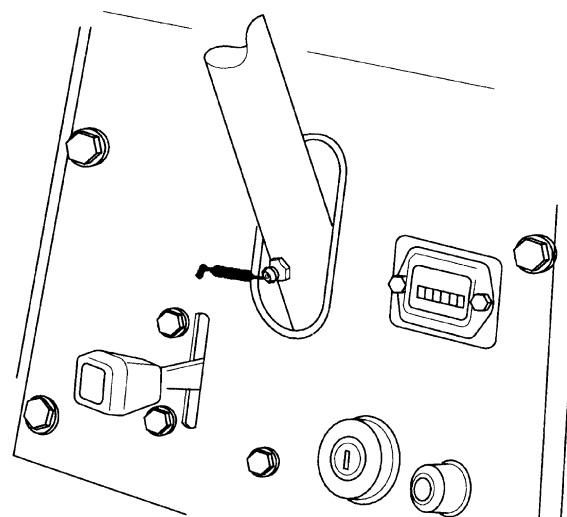

Figure 20

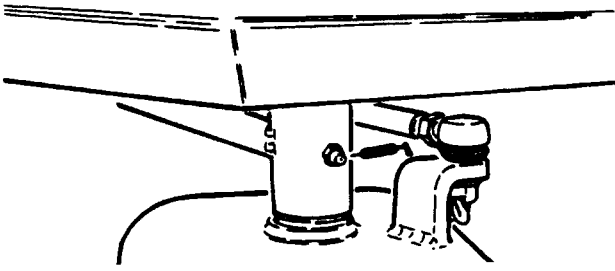

Figure 21

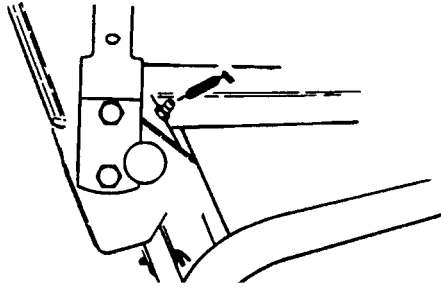

Figure 22

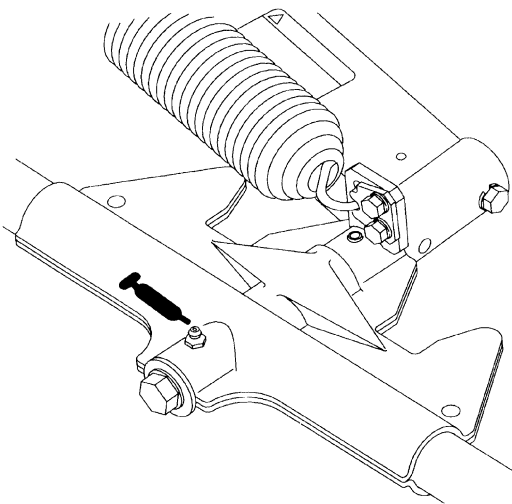

Figure 23

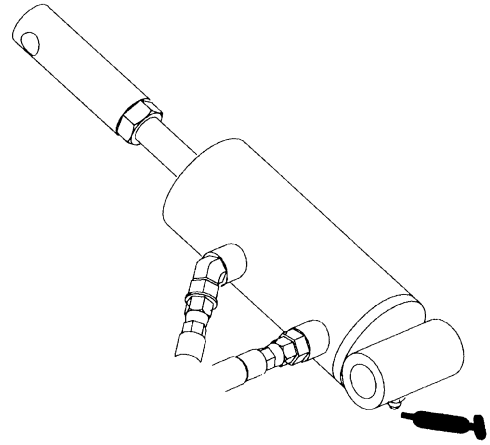

Figure 24

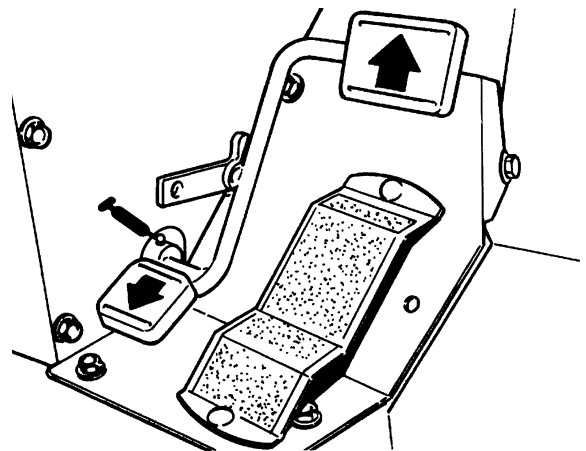

Figure 25

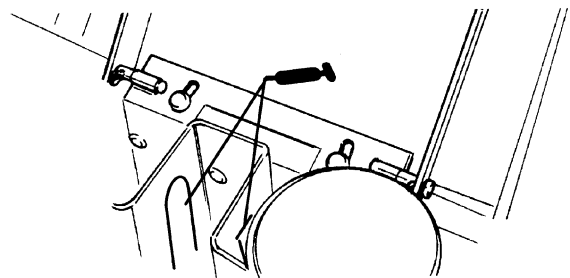

Figure 26

CAUTION

Before servicing or making adjustments to the machine, stop the engine and remove the key from the switch.

Hood Removal

The hood may be easily removed to ease maintenance in the engine area.

1. Unlatch and raise the hood.
2. Remove the cotter pin securing the hood pivot to the mounting brackets.
3. Slide the hood to the right side, lift the other side and pull the hood out of the brackets.
4. Reverse the procedure to install the hood.

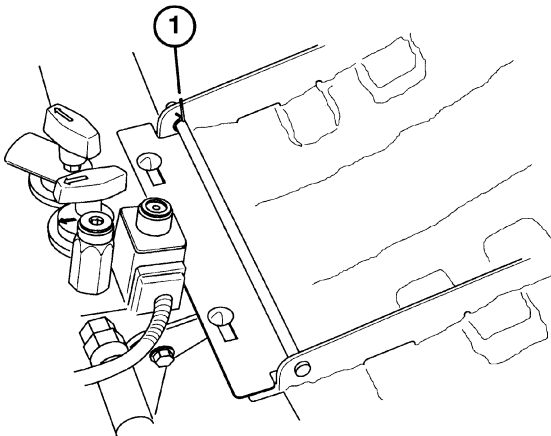

1. Cotter pin

Figure 27

Servicing The Air Cleaner

Service the air cleaner filter every 400 hours, or more frequently in extremely dusty or dirty conditions, by washing or using compressed air.

1. Release the latches that secure the air cleaner cover to the air cleaner body. Separate the cover from the body. Clean inside the air cleaner cover.

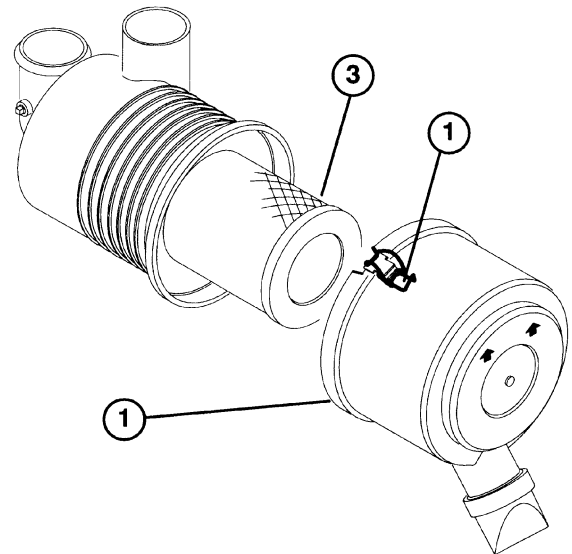

Figure 28

1. Dust Cup & Baffle
2. Filter Element
3. Air Cleaner Body

2. Gently slide the filter out of the air cleaner body to reduce the amount of dust dislodged. Avoid knocking the filter against the air cleaner's body.
3. Inspect the filter and discard it if it is damaged. Do not wash or reuse a damaged filter.

Washing Method

1. Prepare a solution of filter cleaner and water and soak the filter element about 15 minutes.
2. After soaking the filter for 15 minutes, rinse it with clear water.
3. Dry the filter element using warm, flowing air no hotter than 71° C, or allow the element to air dry. Do not use compressed air or a light bulb to dry the filter element because they may damage it.

Compressed Air Method

1. Blow compressed air from inside to the outside of the dry filter element. Do not exceed 689 kPa (100 psi) to prevent damage to the filter.
2. Keep the air hose nozzle at least 3 cm from the pleated paper, and move the nozzle up and down while rotating the filter element.
3. Inspect for holes and tears by looking through the filter toward a bright light.

Installing A New Air Filter

1. Inspect the new filter for shipping damage. Check the sealing end of the filter. Do not install a damaged filter.
2. Insert the new filter into the air cleaner body. Make sure the filter is sealed properly by applying pressure to the outer rim of the filter when installing. Do not press on the flexible center of the filter.
3. Install the cover and secure the latches. Make sure the cover is positioned with the TOP side up.

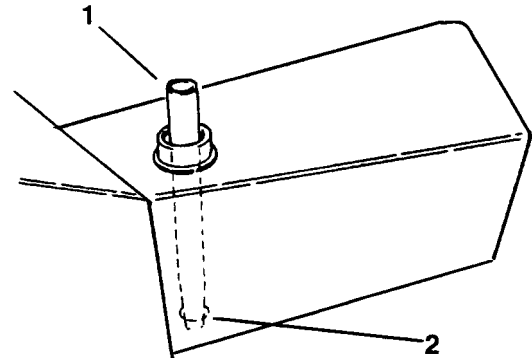

Figure 29

1. Reservoir plug
2. Reservoir outlet

Changing The Engine Oil And Filter

Change the oil and the oil filter initially after the first 20 hours of operation, thereafter change the oil every 50 hours and the oil filter every 100 hours.

1. Locate the engine the oil drain plug on the bottom of the oil pan.. Remove the drain plug and let the oil flow into the drain pan. When the oil stops, install the drain plug.
2. Locate the engine filter on the front of the engine. Remove the oil filter. Apply a light coat of clean oil to the new filter seal before screwing it on. **DO NOT OVER-TIGHTEN.**
3. Add oil to the crankcase.

This will retain most of the fluid in the reservoir when the filter is removed.

3. Clean the area around the hydraulic oil filter. Remove the filter from the bottom of the filter housing and allow the oil to flow into a drain pan. Use a bottom type filter wrench.

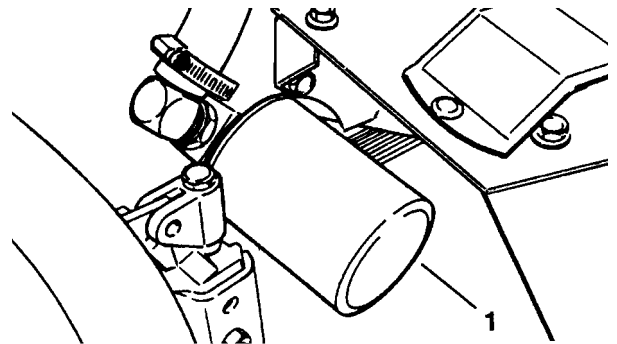

Figure 30

1. Hydraulic oil filter

Changing the Hydraulic System Fluid And Filter

The hydraulic system filter must be changed after the first five hours of operation, and after that, every 250 hours of operation or yearly, whichever comes first. Use a genuine Toro oil filter for replacement. The hydraulic fluid must be changed every 500 hours of operation or yearly, whichever comes first.

1. Park the machine on a level surface, lower the cutting units, set the parking brake and turn the engine off.
2. If only the filter is to be changed, remove the reservoir cap and insert the reservoir plug (Fig. 30), to the block outlet.

4. Apply a film of oil on the filter gasket. Install the filter by hand until gasket contacts mounting head; then tighten the filter an additional three-fourths of a turn.
5. Fill the reservoir to the correct level.
6. Place all controls in the neutral or disengaged position and start the engine. Run the engine at the lowest possible rpm to purge the system of air.
7. Run the engine until the lift cylinder extends and retracts and forward and reverse wheel motion is achieved.
8. Stop the engine and check the oil level in the

reservoir; add oil if necessary.

9. Check all connections for leaks.

Backlapping



DANGER

TO AVOID PERSONAL INJURY OR DEATH:

- Never place your hands or feet in the reel area while the engine is running.
- While backlapping, reels may stall and then restart.
- Do not attempt to restart reels by hand or foot.
- Do not adjust reels while the engine is running.
- If the reel stalls, stop the engine before trying to clear the reel.

1. Position the machine on a clean, level surface, lower the cutting units, stop the engine, engage parking brake and remove key from ignition switch.
2. Unlatch and raise the hood to expose controls.
3. Turn backlap knob, on valve block, clockwise to backlap position. Turn the reel speed knob to position 1.

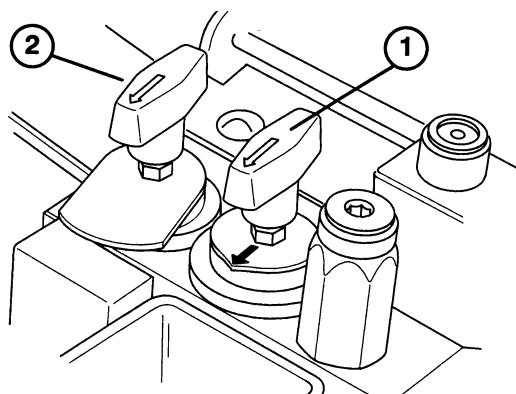

Figure 31

1. Reel speed knob
2. Backlap knob

4. Make initial reel to bedknife adjustments appropriate for backlapping on all cutting units. Start engine and set engine to low idle speed.
5. Engage reels by pulling out knob on instrument

panel

6. Apply lapping compound with long handled brush supplied with machine.



CAUTION

Be careful when lapping the reel because contact with the reel or other moving parts can result in personal injury.

7. To make an adjustment to the cutting units while backlapping, turn reels OFF by pushing in on knob on instrument panel and turning engine OFF. After adjustments have been completed, repeat steps 4-6.
8. When backlap operation is completed, rotate backlap knob clockwise to MOW position, set reel speed controls to desired mowing setting and wash ail lapping compound off cutting units.

NOTE: Additional instructions and procedures on Backlapping are available in the TORO Sharpening Reel & Rotary Mowers Manual Form No. 80-300PT.

NOTE: For a better cutting edge, run a file across the front face of the bedknife when the lapping operation is completed. This will remove any burrs or rough edges that may have built up on the cutting edge.

MODEL AND SERIAL NUMBER

The mower has two identification numbers: a model number and a serial number. The two numbers are stamped into a plate that is riveted to the frame at the rear of the mower. In any correspondence concerning the mower, supply the model and serial numbers to assure that correct information and replacement parts are obtained.

NOTE: Do not order by reference number if a parts catalog is being used; use the part number.

To order replacement parts from an Authorized TORO Service Dealer, supply the following information:

1. Model and serial numbers of the mower.
2. Part number, description and quantity of part(s) desired.

15° and 20° Slope Chart

Align this edge with a vertical surface such as a tree, building, pole, etc.

