



MODEL NO. 30455TS—60001 & UP

OPERATOR'S
MANUAL

GROUNDMASTER® 455-D



7

FOREWORD

This operator's manual has instructions on safety, operation, and maintenance.

This manual emphasizes safety, mechanical and general product information. DANGER, WARNING and CAUTION identify safety messages. Whenever the triangular safety alert symbol appears, understand the safety message that follows. "IMPORTANT" highlights special mechanical information and "NOTE" emphasizes general product information worthy of special attention.

The model and serial number for the traction unit is on a plate that is mounted on the left front frame member. The model and serial number for the cutting unit is on a plate that is mounted on the top front of the center cutting unit. Use model and serial number in all correspondence and when ordering parts.

To order replacement parts from an authorized TORO Distributor, supply the following information:

1. Model and serial numbers of the machine.
2. Part number, description and quantity of parts desired.

Note: Do not order by reference number if a parts catalog is being used; use the part number.

TABLE OF CONTENTS

	Page
Safety	3
Specifications	9
Before Operating	10
Controls	13
First-Time Operation	16
Operating	20
Maintenance	22

PROTOTYPE

SAFETY INSTRUCTIONS

Training

1. Read the instructions carefully. Be familiar with the controls and the proper use of the equipment.
2. Never allow children or people unfamiliar with these instructions to use the lawnmower. Local regulations may restrict the age of the operator.
3. Never mow while people, especially children, or pets are nearby.
4. Keep in mind that the operator or user is responsible for accidents or hazards occurring to other people or their property.
5. Do not carry passengers.
6. All drivers should seek and obtain professional and practical instruction. Such instruction should emphasize:
 - the need for care and concentration when working with rideon machines;
 - control of a ride on machine sliding on a slope will not be regained by the application of the brake. The main reasons for loss of control are:
 - insufficient wheel grip;
 - being driven too fast;
 - inadequate braking;
 - the type of machine is unsuitable for its task;
 - lack of awareness of the effects of ground conditions, especially slopes;

Preparation

1. While mowing, always wear substantial footwear and long trousers. Do not operate the equipment when barefoot or wearing open sandals.
2. Thoroughly inspect the area where the equipment is to be used and remove all objects which may be thrown by the machine.
3. **WARNING—Petrol is highly flammable.**
 - Store fuel in containers specifically designed for

this purpose.

- Refuel outdoors only and do not smoke while refueling.
 - Add fuel before starting the engine. Never remove the cap of the fuel tank or add petrol while the engine is running or when the engine is hot.
 - If petrol is spilled, do not attempt to start the engine but move the machine away from the are of spillage and avoid creating any source of ignition until petrol vapors have dissipated.
 - Replace all fuel tanks and container caps securely.
4. Replace faulty silencers.
 5. Before using, always visually inspect to see that the blades, blade bolts and cutter assembly are not worn or damaged. Replace worn or damaged blades and bolts in sets to preserve balance.
 6. On multi-bladed machines, take care as rotating one blade can cause other blades to rotate.

Operation

1. Do not operate the engine in a confined space where dangerous carbon monoxide fumes can collect.
2. Mow only in daylight or in good artificial light.
3. Before attempting to start the engine, disengage all blade attachment clutches and shift into neutral.
4. Do not use on slopes of more than:
 - Never mow side hills over 5°
 - Never mow uphill over 10°
 - Never mow downhill over 15°
5. Remember there is no such thing as a “safe” slope. Travel on grass slopes requires particular care. To guard against overturning:
 - do not stop or start suddenly when going up or downhill;
 - engage clutch slowly, always keep machine in gear, especially when travelling downhill;

SAFETY INSTRUCTIONS

- machine speeds should be kept low on slopes and during tight turns;
 - stay alert for bumps and hollows and other hidden hazards;
 - never mow across the face of the slope, unless the lawnmower is designed for this purpose.
- 6.** Use care when pulling loads or using heavy equipment.
- Use only approved drawbar hitch points.
 - Limit loads to those you can safely control.
 - Do not turn sharply. Use care when reversing.
 - Use counterweight(s) or wheel weights when suggested in the instruction handbook .
- 7.** Watch out for traffic when crossing or near roadways.
- 8.** Stop the blades rotating before crossing surfaces other than grass.
- 9.** When using any attachments, never direct discharge of material toward bystanders nor allow anyone near the machine while in operation .
- 10.** Never operate the lawnmower with defective guards, shields or without safety protective devices in place.
- 11.** Do not change the engine governor settings or overspeed the engine. Operating the engine at excessive speeds may increase the hazard of personal injury.
- 12.** Before leaving the operator's position:
- disengage the power take-off and lower the attachments;
 - change into neutral and set the parking brake;
 - stop the engine and remove the key.
- 13.** Disengage drive to attachments, stop the engine, and disconnect the spark plug wire(s) or remove the ignition key
- before cleaning blockages or unclogging chute;
 - before checking, cleaning or working on the lawnmower;
 - after striking a foreign object. Inspect the lawnmower for damage and make repairs before restarting and operating the equipment;
- if the machine starts to vibrate abnormally (check immediately).
- 14.** Disengage drive to attachments when transporting or not in use.
- 15.** Stop the engine and disengage drive to attachment
- before refueling;
 - before removing the grass catcher;
 - before making height adjustment unless adjustment can be made from the operator's position.
- 16.** Reduce the throttle setting during engine runout and, if the engine is provided with a shutoff valve, turn the fuel off at the conclusion of mowing.

Maintenance and Storage

1. Keep all nuts, bolts and screws tight to be sure the equipment is in safe working condition.
2. Never store the equipment with petrol in the tank inside a building where fumes may reach an open flame or spark.
3. Allow the engine to cool before storing in any enclosure.
4. To reduce the fire hazard, keep the engine, silencer, battery compartment and petrol storage area free of grass, leaves, or excessive grease.
5. Check the grass catcher frequently for wear or deterioration.
6. Replace worn or damaged parts for safety.
7. If the fuel tank has to be drained, this should be done outdoors
8. On multi-bladed machines, take care as rotating one blade can cause other blades to rotate.
9. When machine is to be parked, stored or left unattended, lower the cutting means unless a positive mechanical lock is used.

SAFETY INSTRUCTIONS

Sound & Vibration Levels

Sound Levels

This unit has an equivalent continuous A-weighted sound pressure at the operator ear of: 87 dB(A), based on measurements of identical machines per 84/538/EEC.

This unit has a sound power level of 104 dB(A)/1pW, based on measurements of identical machines per procedures outlined in Directive 79/113/EEC and amendments

Vibration Levels

This unit has a vibration level of 6.0 m/s² at the posterior, based on measurements of identical machines per ISO 2631 procedures.

This unit does not exceed a vibration level of 0.5 m/s² at the posterior based on measurements of identical machines per ISO 2631 procedures.

PROTOTYPE

Symbol Glossary

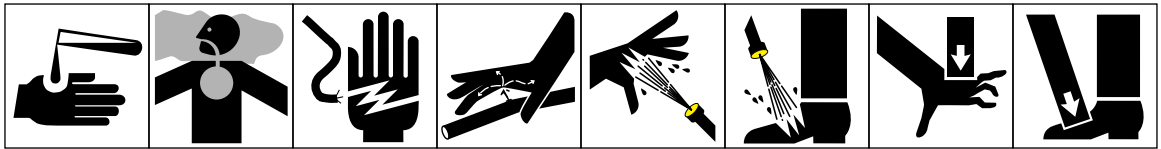

Caustic liquids, chemical burns to fingers or hand
 Poisonous fumes or toxic gases, asphyxiation
 Electrical shock, electrocution
 High pressure fluid, injection into body
 High pressure spray, erosion of flesh
 High pressure spray, erosion of flesh
 Crushing of fingers or hand, force applied from above
 Crushing of toes or foot, force applied from above

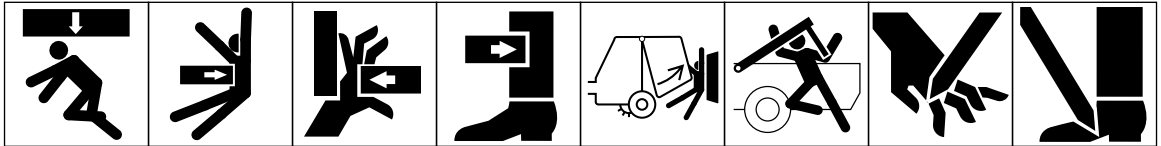

Crushing of whole body, applied from above
 Crushing of torso, force applied from side
 Crushing of fingers or hand, force applied from side
 Crushing of leg, force applied from side
 Crushing of whole body
 Crushing of head, torso and arms
 Cutting of fingers or hand
 Cutting of foot

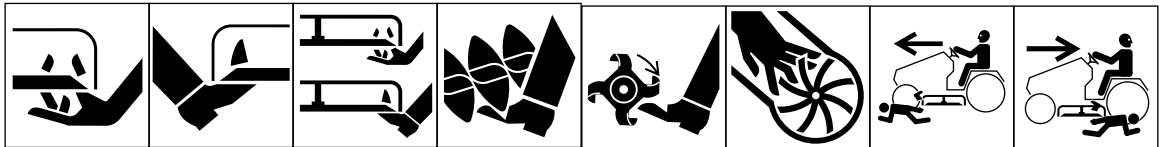

Severing of fingers or hand, mower blade
 Severing of toes or foot, mower blade
 Severing of toes or fingers, rotary mower blade
 Cutting or entanglement of foot, rotating auger
 Severing of foot, rotating knives
 Severing of fingers or hand, impeller blade
 Dismemberment, front engine mower in forward motion
 Dismemberment, front engine mower in rearward motion

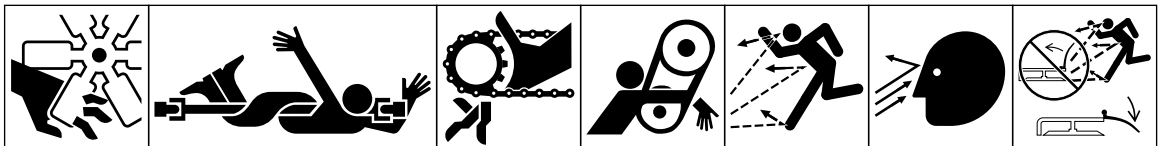

Severing of fingers or hand, engine fan
 Whole body entanglement, implement input drive line
 Fingers or hand entanglement, chain drive
 Hand & arm entanglement, belt drive
 Thrown or flying objects, whole body exposure
 Thrown or flying objects, face exposure
 Thrown or flying objects, rotary mower

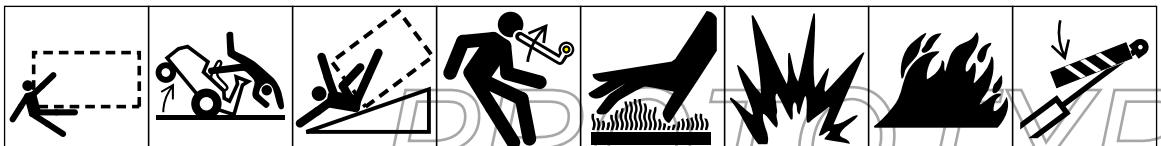

Runover/backover, vehicle
 Machine tipping, riding mower
 Machine rollover, ROPS (rear engine mower)
 Stored energy hazard, kickback or upward motion
 Hot surfaces, burns to fingers or hands
 Explosion
 Fire or open flame
 Secure lifting cylinder with locking device before getting in hazardous area

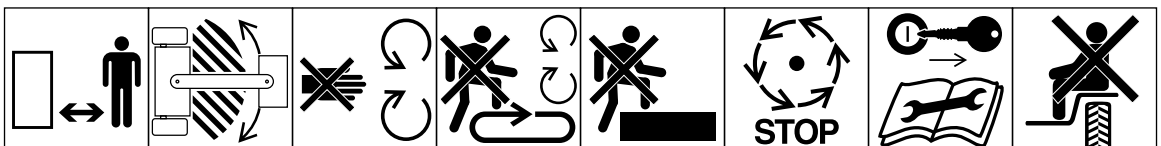

Stay a safe distance from the machine
 Stay clear of articulation area while engine is running
 Do not open or remove safety shields while engine is running
 Do not step on loading platform if PTO is connected to tractor & engine is running
 Do not step
 Wait until all machine components have completely stopped before touching them
 Shut off engine & remove key before performing maintenance or repair work
 Riding on this machine is allowed only on a passenger seat & only if the driver's view is not hindered

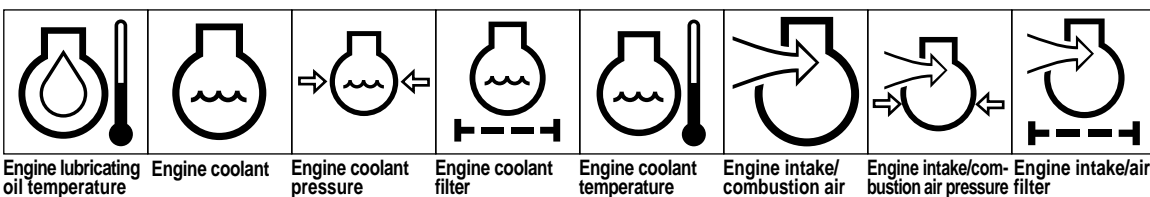
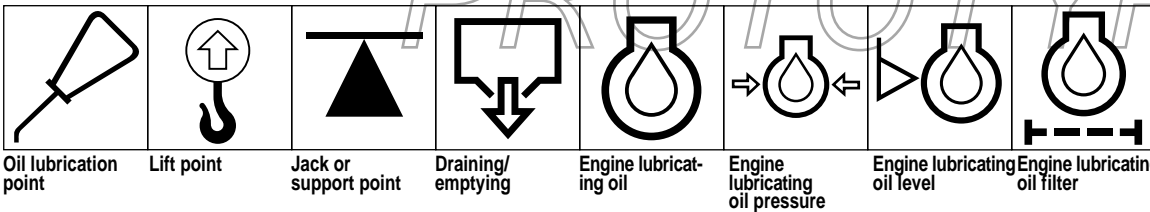
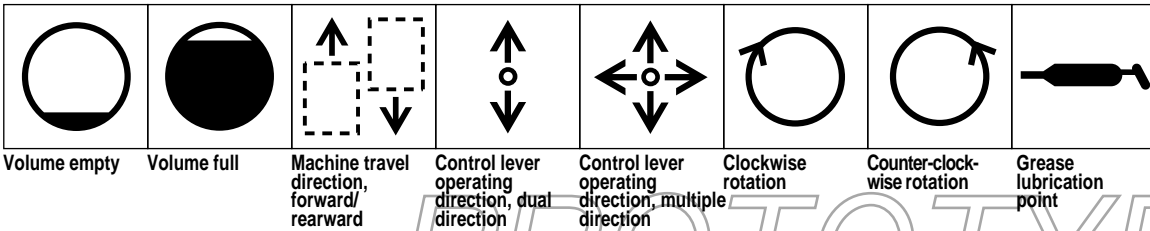
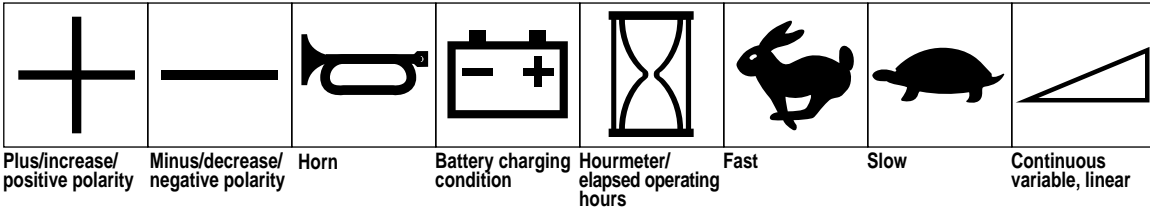
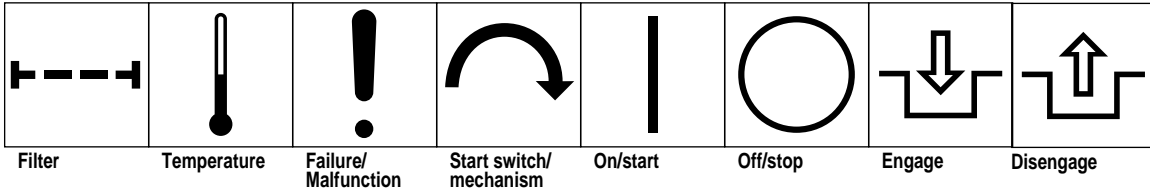
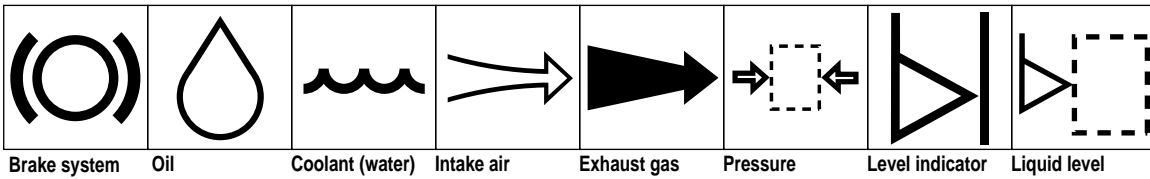
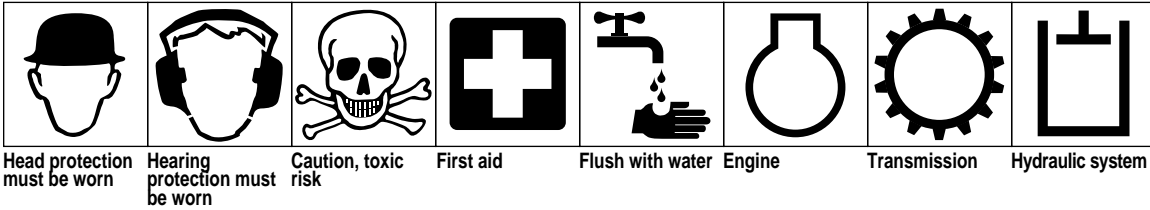
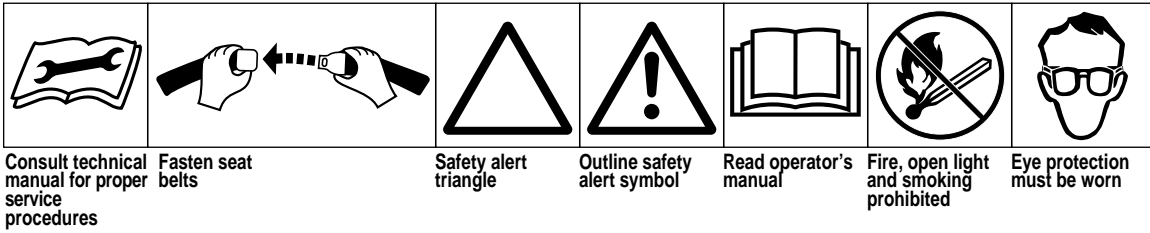

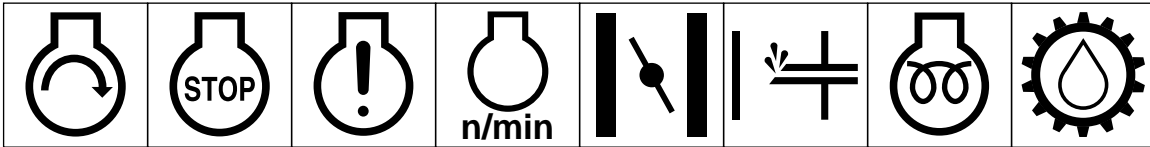

Engine start Engine stop Engine failure/malfunction Engine rotational speed/frequency Choke Primer (start aid) Electrical preheat (low temperature oil start aid) Transmission

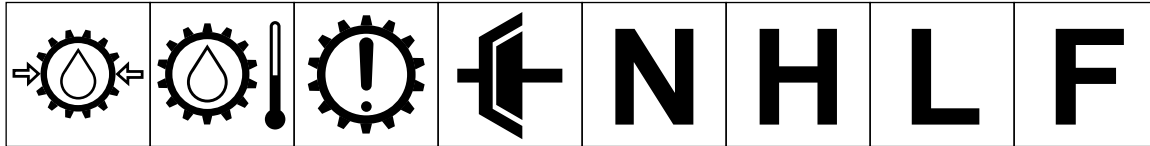

Transmission oil pressure Transmission oil temperature Transmission failure/malfunction Clutch Neutral High Low Forward

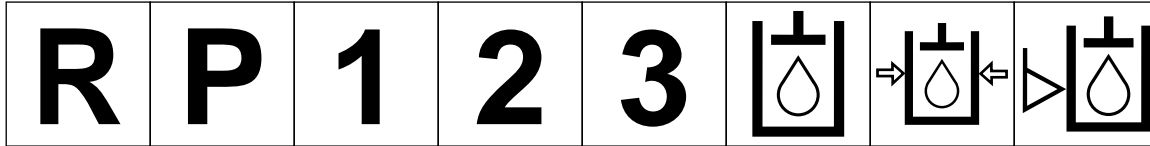

Reverse Park First gear Second gear Third gear (other #'s may be used until the maximum # of forward gears is reached.) Hydraulic oil Hydraulic oil pressure Hydraulic oil level

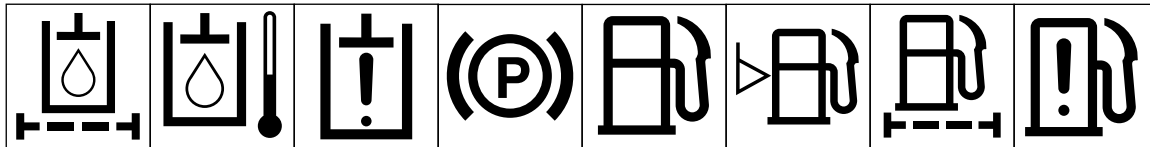

Hydraulic oil filter Hydraulic oil temperature Hydraulic oil failure/malfunction Parking brake Fuel Fuel level Fuel filter Fuel system failure/malfunction

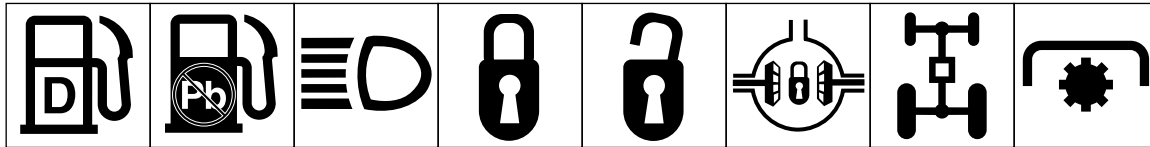

Diesel fuel Unleaded fuel Headlights Lock Unlock Differential lock 4-Wheel drive Power Take-Off

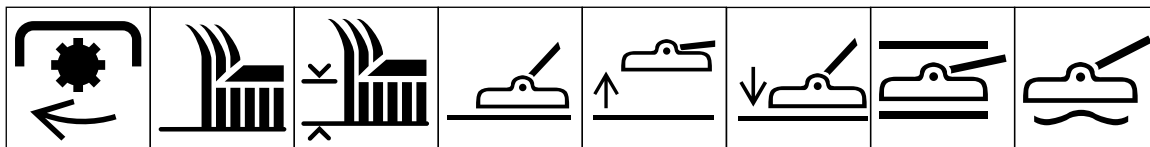

Power Take-Off, rotational speed Blade cutting element Blade cutting element, height adjustment Cutting unit Cutting unit, raise Cutting unit, lower Cutting unit, hold Cutting unit, float

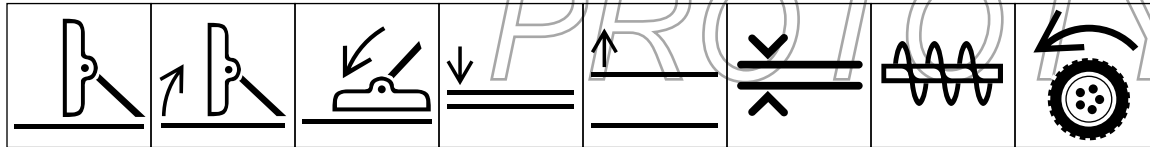

Cutting unit, transport position Cutting unit, raise to transport position Cutting unit, lower to transport position Attachment raise Attachment raise Spacing distance Snow thrower, collector auger Traction

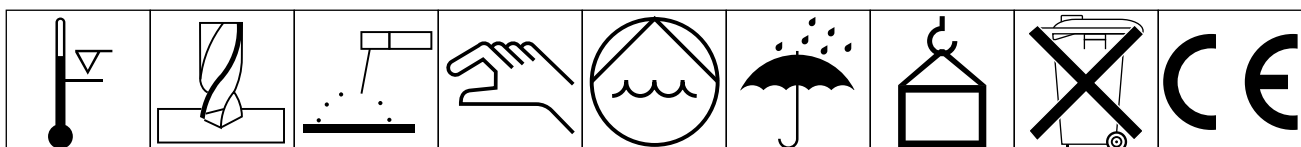

Above working temperature range Drilling Manual metal arc welding Manual Water pump Keep dry Weight Do not dispose in the garbage CE logo

SPECIFICATIONS

Traction Unit

Engine: Peugeot, four-cycle, four-cylinder, 1.9 liter (1,900 cc) displacement, liquid-cooled diesel engine. 23.5:1 compression ratio. Low idle—1,500 rpm, high idle—3,000 rpm. Oil capacity is 5.3 qts. with filter.

Cooling System: Capacity is 3.5 gal. of 50/50 mixture of Peugeot recommended anti-freeze.

Fuel System: Capacity is 53 liter (14 gallon) of #1 or #2 diesel fuel.

Hydraulic System: Reservoir capacity is 24.6 liters (6.5 gallon). Replaceable spin-on filter element.

Traction System: Ground speed: Low Range; 0–10.5 kmh, 0–6.5 mph (0–5.5 mph. with mechanical speed limiter interlock) forward and 0–4.8 kmh, 0–3 mph reverse. High Range): 0–24.1 kmh, 0–15 mph (0–20 kmh, 0–12.4 m.p.h. with mechanical speed limiter interlock) forward and 0–8 kmh, 0–5 mph reverse.

Front Axle: Two-speed axle. Separate mowing and transport selections for faster and more efficient machine operation. Lubricated with SAE 80–90 weight, EP gear lubrication. Capacity is 128 oz.

Rear Axles: Two-Wheel Drive—The large diameter wheel spindles are designed for durability and long wear, yet provide superior stability and maneuverability. Four-Wheel Drive, Heavy-duty, agricultural type. Lubricated with SAE 80–90 weight, EP gear lubrication. Capacity is 2.4 kg (80 oz).

Tires/Wheels: Front tires: (2) 26 x 12.0-12, 8 ply. Rear tires: (2) 20 x 10.0-10, 6 ply. Tire pressure 138 kPa (20 psi).

Seat: Adjustable fore and aft travel and weight.

Diagnostic System: Test ports for: forward and reverse traction (2-wheel drive), front and rear axle motors (4 wheel drive), lift and counterbalance circuit, steering circuit and charge circuit.

Steering System: Automotive type, full power.

Brakes: Totally enclosed, non asbestos, dry multi-disc individual wheel and parking brakes on the front traction wheels.

Electrical System: 12-volt battery with 530 cold cranking Amps @ -18°C (0°F). 55-amp alternator, ammeter, starter, key switch and automatic temperature controlled glow plug controller. Separately-fused run, deck and instrument/accessory circuits.

Interlock System: Stops the engine if operator gets off the seat while the cutting deck drive switch is engaged or the traction pedal is forward or reverse. Prevents the engine from starting unless the traction pedal is in neutral and the cutting deck is disengaged. Prevents the cutting deck from operating unless the axle shift is in LO range.

Warning Lights:

Glow plug indicator
Engine oil pressure warning
Engine coolant temperature warning
Charge indicator

Indicators:

Engine coolant temperature gauge
Fuel gauge
Hour meter

The Cutting Unit

Type: 320 cm (126 inch) width of cut, seven-blade, front-mounted rotary. 137 cm (54 inch) width of cut, three-blade center section. Two 94 cm (36 inch) width of cut wings; 229 cm (90 in.) width of cut with one wing up. Rear discharge with even dispersion over the entire width of cut.

Mowing Rate: Mows up to #8 acres/hr. at 10.5 kmh (6.5 mph).

Trimability: Trims on both sides.

Height-of-Cut: Adjustable from 2.5–12.7 cm (1–5 inches) in 1.2 cm (0.5 inch) increments.

Blades: Seven 48 cm (19 inches) long, 6 mm (1/4") thick, and 64 mm (2-1/2 in.) wide, heat treated steel blades.

Belt Idlers: Self-tensioning permanently lubricated idlers.

Wing Decks: Wings can be hydraulically raised from the operator's seat for transport or cutting with either wing and center deck or center deck only. Wings cut from level to 15° up and down. Further lift disengages the blade and applies a blade brake.

SPECIFICATIONS

Suspension/Caster Wheels: Four front and two rear castor tires. Center deck tires: 26–8.3 cm (10.25 in. x 3.25 in.). Wing deck tires: 20 x 8.3 cm (8 in. x 3.25 in. An anti-scalp cup is located on each blade. Three anti-scalp rollers on the center deck.

General Specifications (approx.):

Overall Length:

With the deck installed 340 cm (134 in.)

Overall Width:

Transport 190.5 cm (75 in.)

Mowing 323 cm (127 in.)

Height:

147 cm (58 in.)

With rollover protection system installed

208 cm (82 in.)

Wheel Tread:

(Front) 132 cm (52 in.)

(Rear) 112 cm (44 in.)

Wheel Tread: 142 cm (56 in.)

Dry Weight:

2-Wheel Drive 1,288 kg (3,450 lb)

4-Wheel Drive 1,325 kg (3,550 lb)

Optional Equipment

Roll Over Protection Kit, Contact Your Local Toro Distributor
(Standard on Model 30455)

Arm Rest Kit, Model 30707

Rotary Radiator Screen Kit, Model No. 03652

Canopy Kit, Contact Your Local Toro Distributor

Spark Arrestor Muffler, Part No. 77-3990

Gear Box Pulley (Tip Speed 14,500), Part No. 86-3100

PROTOTYPE

BEFORE OPERATING

Check The Engine Oil (Fig. 1 & 2)

Crankcase capacity is 5 liters (5.3 qt) with filter.

1. Park the machine on a level surface. Release the hood latch and open the hood.
2. Remove the dipstick from the tube cap, wipe it clean and reinstall the dipstick into the tube cap. Pull it out again and check the oil level on the dipstick: The oil level must always be in the notch area on the dipstick.
3. If the oil level is low, remove the tube cap and add SAE 10W-30 CD oil until the level reaches the top of notch on the dipstick. **DO NOT OVERFILL.**
4. Install the oil tube cap.
5. Close the hood and secure the latch.

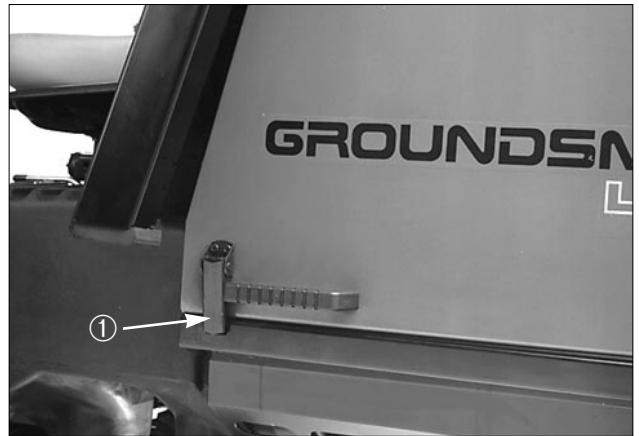

Figure 1

1. Hood latch

Check The Cooling System (Fig. 3)

Capacity of the system is 13.2 liters (3.5 gal).

1. Park the machine on a level surface. Release the hood latch and open the hood.
2. The coolant level should be up to or above the mounting tabs on the degasser tank, when the engine is cold.
3. If the coolant is low, remove the degasser tank cap and add a 50/50 mixture of water and Peugeot recommended anti-freeze. **DO NOT USE WATER ONLY OR ALCOHOL/METHANOL BASE COOLANTS.**

IMPORTANT: Do not remove the black plastic cap on the degasser tank.

4. Install the degasser tank cap.
5. Close the hood and secure the latch.



Figure 2

1. Dipstick/Tube Cap

Fill The Fuel Tank (Fig. 4)

1. Park the machine on a level surface. Release the hood latch and open the hood.

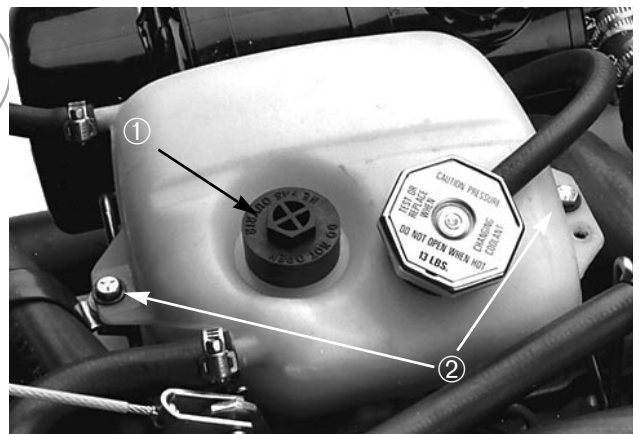

Figure 3

1. Degasser tank 2. Mounting tube

BEFORE OPERATING

CAUTION

Before servicing or making adjustments to the machine, stop the engine and remove the key from the switch

2. Remove the fuel tank cap.
3. Fill the tank to no more than one inch below the bottom of the filler neck with No. 2 diesel fuel. DO NOT OVER FILL. Then install the cap.

Note: For temperatures below 0° C (32° F), No. 1 diesel fuel or a blend should be used.

4. Close the hood and secure the latch.



Figure 4

1. Fuel tank cap

Check The Hydraulic Circuit Oil (Fig. 5)

The hydraulic system is designed to operate on Mobil DTE 26 or equivalent anti-wear hydraulic fluid. The machine's reservoir is filled at the factory with 24.6 liters (6.5 gal.) of fluid. However, check the level of hydraulic fluid before the engine is first started and daily thereafter. **Hydraulic Oil (Recommended brands):**

Mobil	DTE 26
Shell	Tellus 68
Amoco	Rykon Oil #68
Conoco	Super Hydraulic Oil 68
Exxon	Nuto 68
Kendall	Kenoil R&O AW 68
Pennzoil	Penreco 68
Phillips	Magnus A 68
Standard	Energol HLP 68
Sun	Sunvis 831 WR
Union	Unax AW 68
Chevron	AW Hydraulic Oil 68

Note: All are interchangeable.

IMPORTANT: Use only the hydraulic oils specified. Other fluids could cause system damage.

Note: A red dye additive for the hydraulic system oil is available in 20 ml (2/3 oz) bottles. One bottle is sufficient for 15–23 liters

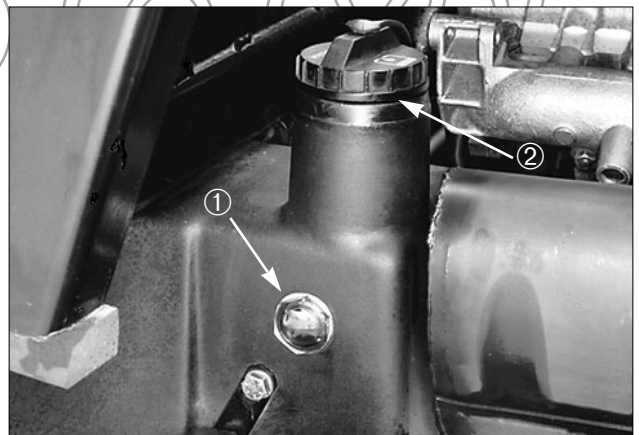

Figure 5

1. Sight gauge
2. Hydraulic reservoir cap

BEFORE OPERATING

(4–6 gal) of hydraulic oil. Order Part No. 44-2500 from your authorized Toro distributor

1. Park the machine on a level surface. Make sure the machine has been operated so the oil is warm. Release the hood latch and open the hood. Check the oil level by viewing the sight gauge. If oil is visible in the gauge, the oil level is sufficient.
2. If the oil level is not visible in the gauge, remove the cap from the hydraulic oil reservoir and slowly add Mobil DTE 26 or equivalent hydraulic oil until the level reaches the middle (maximum) of the sight gauge. DO NOT OVER FILL.

IMPORTANT: To prevent system contamination, clean the tops of hydraulic oil containers before puncturing. Make sure the pour spout and funnel are clean.

DANGER

Because diesel fuel is highly flammable, use caution when storing or handling it. Do not smoke while filling the fuel tank. Do not fill the fuel tank while the engine is running, hot, or when the machine is in an enclosed area. Always fill the fuel tank outside and wipe up any spilled diesel fuel before starting the engine. Store the fuel in a clean, safety-approved container and keep the cap in place. Use diesel fuel for the engine only; not for any other purpose.

3. Install the reservoir cap, close the hood and secure the latch.

Check The Front Axle Oil Level (Fig. 6 & 7)

The front axle is shipped from the factory filled with SAE 80–90 weight gear lubrication. However, check the level before the engine is first started and every 50 hours thereafter.

1. Park the machine on a level surface.
2. Remove the access panel (Fig. 6), in the front of the seat, to expose the front axle/dipstick.
3. Unscrew the dipstick cap (Fig. 7) from the filler neck



Figure 6

1. Access panel

BEFORE OPERATING

and wipe it with a clean cloth. Screw the dipstick cap finger tight onto the filler neck. Unscrew the dipstick and check the level of lubricant. If the level is not within 12 mm (1/2 in.) from the groove in the dipstick, add enough to raise the level to groove mark. **DO NOT OVERFILL** by more than 12 mm (1/2 inch) above the groove.

4. Screw the dipstick filler cap finger-tight onto the filler neck. It is not necessary to tighten the cap with a wrench.

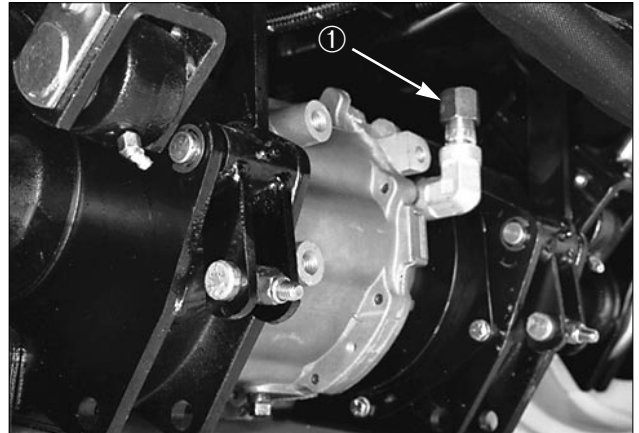

Figure 7

1. Dipstick Cap

Check The Rear Axle Lubricant (Model 30455 Only) (Fig. 8)

The rear axle is shipped from the factory filled with SAE 80–90 weight gear lubrication. However, check the level before the engine is first started and every 50 hours thereafter. Capacity is 2.5 kg. (80 oz).

1. Position the machine on a level surface.
2. Remove a check plug from one end of the axle and make sure lubricant is up to the bottom of the hole. If the level is low, remove the fill plug and add enough lubricant to bring the level up to the bottom of the check plug holes.

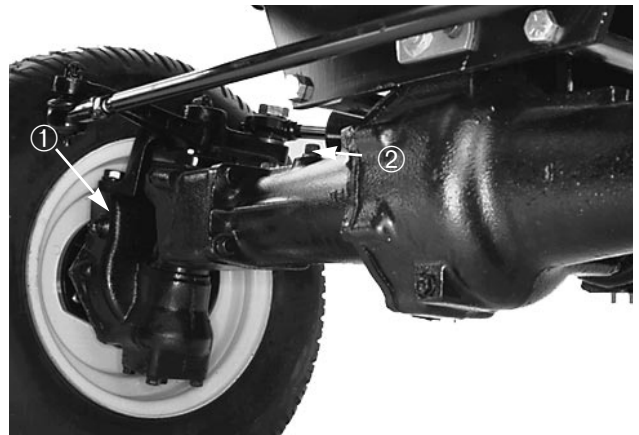

Figure 8

1. Check plug
2. Fill plug

Check Tire Pressure

The tires are over-inflated for shipping. Therefore, release some of the air to reduce the pressure. Correct air pressure in the front and rear tires is 138 kPa (20 psi).

IMPORTANT: Maintain even pressure in all tires to assure a good quality-of-cut and proper machine performance. DO NOT UNDER INFLATE.

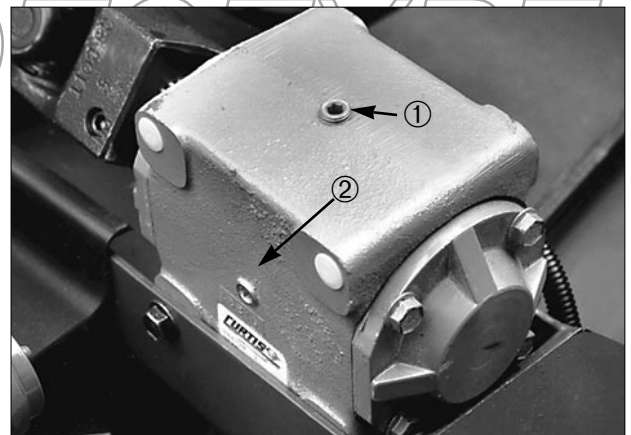

Figure 9

1. Filler plug
2. Check plug

BEFORE OPERATING

Check The Torque Of Wheel Nuts Or Bolts



WARNING

Torque the front wheel nuts to 45–55 ft-lb and the rear wheel nuts or bolts to 85–100 ft lb after 1–4 hours of operation and again after 10 hours of operation and every 250 hours thereafter. Failure to maintain correct torque could result in failure or loss of the wheel and may result in personal injury.

Check The Lubricant In The Gear Box (Fig. 9)

The gear box is designed to operate on SAE 80–90 weight gear lubrication. Although the gear box is shipped with lubricant from the factory, check the lubricant's level before operating the cutting unit.

1. Position the machine and cutting unit on a level surface.
2. Remove the check plug from the side of the gear box and make sure lubricant is up to the bottom of the hole. If the level of lubricant is low, remove the fill plug on top of the gear case and add enough lubricant to bring it up to the bottom of the hole inside.

Adjusting The Height-Of-Cut (Fig. 10–12)

The height-of-cut is adjustable from 2.5–12.7 cm (1 to 5 inches) in 12.7 mm (0.5 inch) increments. Positioning the castor wheel axles in the top holes of the castor forks or pivots (see chart below) allows low-range height-of-cut settings from 2.5–8.3 cm (1 to 3-1/2 in); positioning the castor wheel axles in the lower holes of the front castor forks or rear castor pivots (see chart below) allows a high-range height-of-cut settings from 6–12 cm (2-1/2 to 5 in.)

1. Start the engine and raise the cutting unit so the height-of-cut can be changed. Stop the engine after the cutting unit is raised.
2. Position all castor wheel axles in the same holes in the castor forks or pivots.

HEIGHT OF CUT—FRONT CASTOR WHEELS

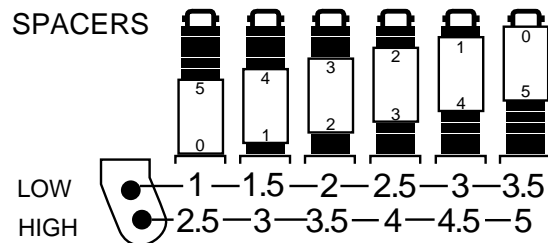

HEIGHT OF CUT
—REAR CASTOR WHEELS

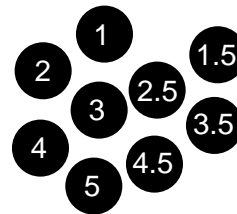

HEIGHT OF CUT
—REAR DECK STRAPS

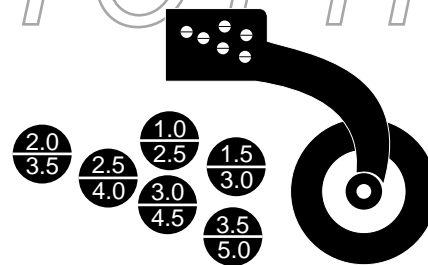

BEFORE OPERATING

Front Castor Wheels

1. Remove the lynch pin from the spindle shaft and slide the spindle out of the front castor arm. Slide spacers onto the spindle shaft to get the desired height-of-cut.
2. Push the castor spindle through the front the castor arm install remaining spacers onto the spindle and install the lynch pin to secure the assembly.

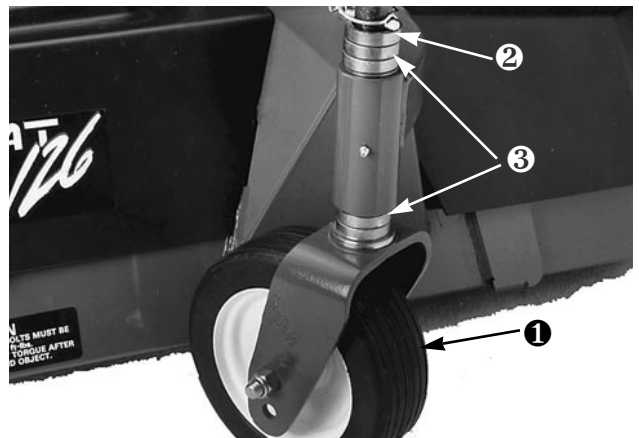

Figure 10

1. Front Castor Wheel
2. Lynch pin
3. Spacers

Rear Castor Wheels

1. Remove the hairpin cotter and H.O.C. pin securing the rear castor pivot arm to the deck bracket.
2. Align the pivot arm holes with selected height-of-cut bracket holes in the deck frame, install the height-of-cut pin and secure with the hairpin cotter.

Rear Deck Straps

1. Lower the center and wing cutting units to the ground: then raise the center cutting unit slightly, until the rear deck straps hang freely on the lift arm brackets. Stop the engine after the cutting unit is raised.
2. Remove the hairpin cotter and H.O.C. pin securing the rear deck strap to H.O.C. bracket on the deck.
3. Slide the deck strap forward or backward until the holes in strap are aligned with selected height-of-cut bracket holes in the deck frame, install H.O.C. pin and secure with the hairpin cotter.



Figure 11

1. Rear Castor Pivot

Safety Doors (Fig. 13)

On each side of the center deck is a safety door that opens and closes as the wing decks are lowered and raised (Fig. 13). The doors open to provide overlap of the cutting blades when the wing units are down. The doors close to provide safety and protection

CAUTION

Check for correct operation of the safety doors each time the deck is cleaned and repair when needed.

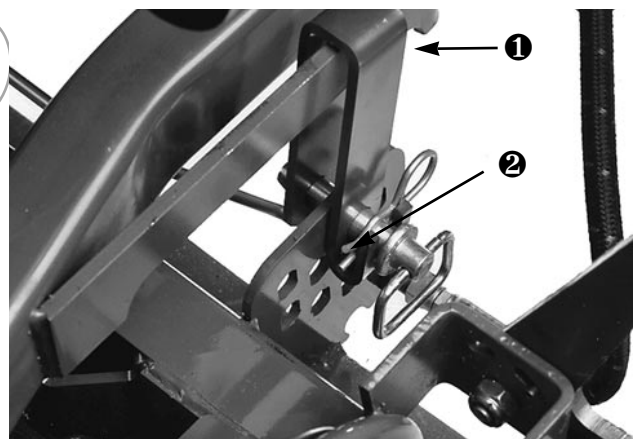

Figure 12

1. Rear Deck Straps
2. Lift Arm Brackets

CONTROLS

when the wing units are raised. Check to make sure the forward, lower edge of door is even or 6 mm (1/4 in.) higher than lower edge of door guide when wing decks are in the fully raised, transport position. If an adjustment to the door is required, refer to *Adjusting The Safety Door*.

Cutting Unit Engagement Switch (Fig. 14)—Used to start and stop cutting unit operation. Lift switch and move forward to actuate the cutting unit. Center deck will engage first followed by wing decks engaging approximately one second later.

Glow Plug Indicator (Fig. 14)—Automatically actuates proper glow period when the ignition key is turned to ON. Illuminates when the glow plugs are actuated. When the glow plugs are heated sufficiently, light goes off indicating the engine is ready to start.

Charge Indicator (Fig. 14)—Illuminates when the system charging circuit malfunctions.

Key Switch (Fig. 14)—Three positions: OFF, ON and START. Turn the key to START and release it when the engine begins running. To stop the engine, turn the key to OFF.

Throttle Control (Fig. 14)—Move control forward to increase the engine speed, backward to decrease speed.

Cutting Unit Lift Controls (Fig. 14)—The two outside levers raise and lower the wing cutting units. The center lever raises and lowers the whole cutting unit. The engine must be running to lower the cutting unit. When wing cutting units are raised higher than 15°, their blades automatically disengage. To lower the cutting unit just touch the levers momentarily.

Coolant Temperature Gauge (Fig. 14)—Shows the temperature of engine coolant.

Fuel Gauge (Fig. 14)—Shows the amount of fuel in the tank.

Hour Meter (Fig. 14)—Shows the total hours the machine has been operated.

Engine Oil Pressure Warning Light (Fig. 14)—Indicates dangerously low engine oil pressure.

Engine Coolant Temperature Warning Light (Fig. 14)—The red light illuminates and the engine stops when temperature of the coolant exceeds 110° C (230° F).

Seat (Fig. 15)—Seat adjusting lever on the left side of the seat

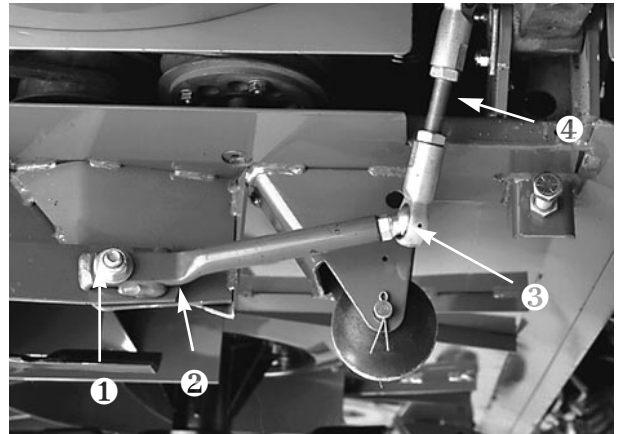

Figure 13

- | | |
|----------------|-----------------|
| 1. Safety door | 3. Ball joint |
| 2. Door guide | 4. Threaded rod |

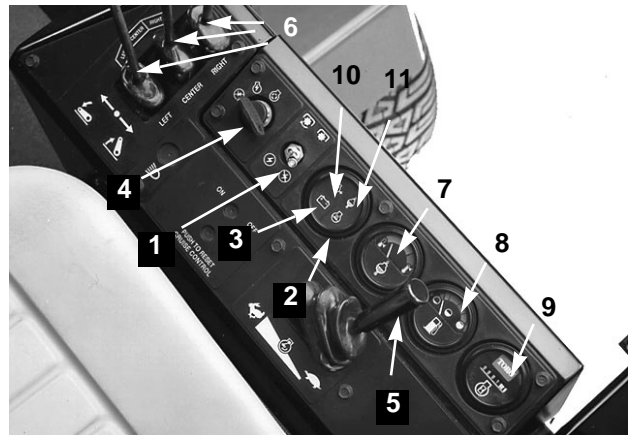

Figure 14

- | |
|--|
| 1. Cutting unit engagement switch |
| 2. Glow plug indicator |
| 3. Charge indicator |
| 4. Key switch |
| 5. Throttle control |
| 6. Cutting unit lift controls |
| 7. Coolant temperature gauge |
| 8. Fuel gauge |
| 9. Hour meter |
| 10. Engine oil pressure warning light |
| 11. Engine coolant temperature warning light |

CONTROLS

allows 4 inch fore and aft adjustment. The seat adjusting knob on the front of the seat, adjusts the seat for operator's weight.

Traction Pedal (Fig. 16)—Controls forward and reverse operation. Depress the top of the pedal to move forward and the bottom to move backward. Ground speed depends on how far the pedal is depressed. For no load, maximum ground speed, fully depress the pedal while the throttle is in FAST. For maximum power under load or when going uphill, keep the engine rpm high by having the throttle in FAST and the traction pedal partially engaged. If engine rpm begins to decrease due to load, gradually reduce the traction pedal pressure until engine speed is increased.

To stop, reduce foot pressure on the traction pedal and allow it to return to the center position. On extreme downhill slopes, apply pressure to REVERSE side of the pedal, or operate with heel on REVERSE and toe on FORWARD portion of the pedal.

Speed Selector (Fig. 16)—The cam lever at the side of the traction pedal can be rotated to maintain the desired speed. Rotating the lever forward decreases speed and backward increases speed.

Axle Shift Lever (Fig. 16)—Located on the right side of console, the lever selects the front drive mode. Pull out the lock-out knob, move the lever rearward for mowing operation and forward for transport operation, then release the knob to lock the selection. The lever must be in LO position to mow. Middle position (N) is for towing.

IMPORTANT: On model 30455, the lever must be in LO to operate in 4-wheel drive.

CAUTION: The machine must be on a flat surface and the brakes engaged when shifting the axle from HI to LO

Brake Pedals (Fig. 17)—Two foot pedals at the lower left operate individual wheel brakes for turning assistance, parking and for better side hill traction. The locking pin is for parking.

Parking Brake Latch (Fig. 17)—A knob on the left side of console actuates the parking brake lock. To engage the parking brake, connect the pedals with the locking pin, push down on both pedals and pull the parking brake latch out. To release the parking brake, depress both pedals until the parking brake latch retracts.

Steering Wheel Tilt Lever (Fig. 17)—The lever on the left side of console lets the steering wheel to be adjusted for operator comfort.

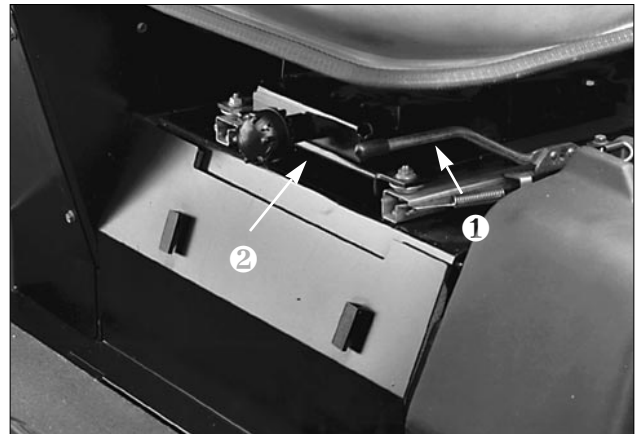

Figure 15

1. Seat adjusting lever
2. Seat adjusting knob



Figure 16

1. Traction pedal
2. Speed Selector
3. Axle shift lever
4. Lockout knob

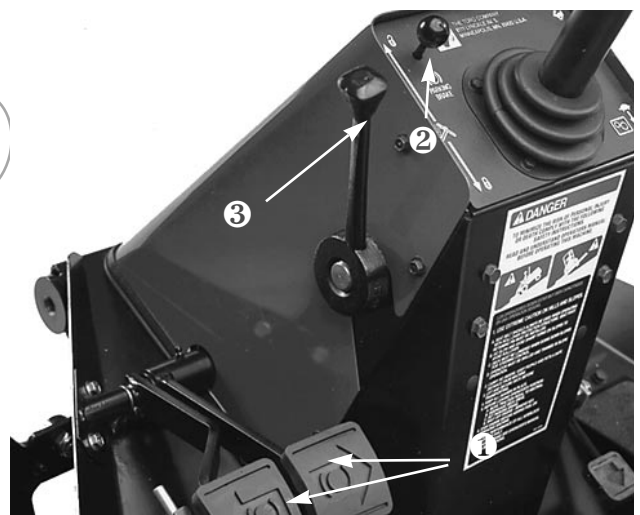

Fig. 17

1. Brake pedals
2. Parking brake latch
3. Steering wheel tilt lever

CONTROLS

Transport Latches (Fig. 18)—Four latches secure the cutting unit and wings in upright position for transport.

Horn—In the center of steering wheel. Operates only when the key switch is in ON.



Figure 18

1. Transport latch (4)

PROTOTYPE

CONTROLS

Starting And Stopping

1. Sit on the seat and keep your foot off the traction pedal. Assure the parking brake is engaged, the traction pedal is in NEUTRAL and the cutting unit engagement switch is in the DISENGAGED position.
2. Turn the ignition switch to ON. When the glow plug indicator light goes off, the engine is ready to START.
3. Turn the ignition key to START. Release the key when the engine starts.
4. To stop, disengage and move all controls to NEUTRAL and set the parking brake. Turn the key to OFF and remove it from switch. Raise and latch all the cutting units in transport position.

Priming The Fuel The System (Fig. 19 & 20)

IMPORTANT: The fuel system may need to be primed when a new engine is started for the first time, if it runs out of fuel or if maintenance is performed on the fuel system.

1. Unlatch and raise the hood.
2. Insert a 48 mm (3/16) hose over bleed screw and run other end into a container to catch fuel.
3. Loosen the fuel filter/water separator bleed screw (Fig. 19) a few turns. Pump the priming plunger until a steady stream of fuel comes out of the hole in the bleed screw. When fuel stops foaming, tighten the bleed screw during the down stroke of the priming plunger. Wipe up any spilled fuel.
4. Pump the priming plunger until resistance is felt. Try to start the engine. If the engine does not start repeat step 3.

Note: It may be necessary to bleed the air out of the fuel line between the fuel filter/water separator and the injection pump. To do this, loosen the fitting on the injection pump (Fig. 20) and repeat bleeding procedure.



Figure 19

1. Hood plunger
2. Bleed screw

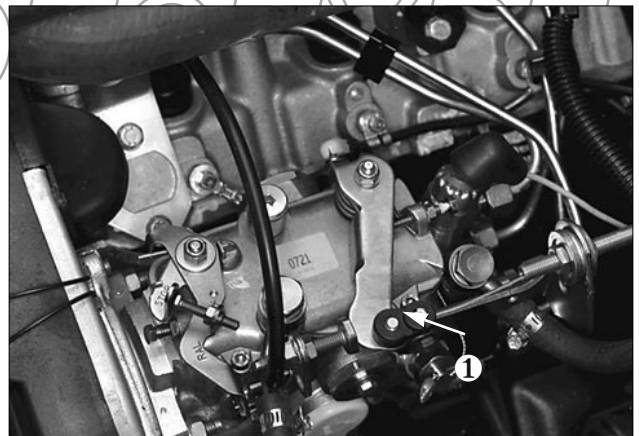

Figure 20

1. Injection pump fitting

OPERATING INSTRUCTIONS

Checking The Interlock System

The purpose of the interlock system is to prevent the engine from cranking or starting unless the traction pedal is in NEUTRAL and the cutting unit engagement switch is DISENGAGED. Also, the engine will stop when the cutting unit engagement switch is engaged or the traction pedal is depressed with the operator off the seat.



CAUTION

The interlock switches are for the operator's protection, so do not disconnect them. Check switch operation daily to assure the interlock system is operating. If a switch is defective, replace it before operating. Regardless of whether the switches operate correctly or not, replace them every two years to assure maximum safety. Do not rely entirely on safety switches—use common sense!

1. In a wide open area free of debris and bystanders, lower the cutting unit to the ground. Stop the engine.
2. Move the cutting unit engagement switch to DISENGAGED and remove your foot from the traction pedal so it is fully released.
3. Turn the ignition key to START. The engine should start. If the engine starts, go to step 4. If the engine does not start, there may be a malfunction in the interlock system.
4. Rise from the seat and engage the cutting unit engagement switch while the engine is running. The engine should stop within 2 seconds. If the engine stops, the switch is operating correctly; go to step 5. If the engine does not stop, there is a malfunction in the interlock system.
5. Rise from the seat and depress the traction pedal while the engine is running and the cutting unit engagement switch is DISENGAGED. The engine should stop within 2 seconds. If the engine stops, the switch is operating correctly; continue operation. If the engine does not stop, there is a malfunction in the interlock system.

PROTOTYPE

OPERATING INSTRUCTIONS

Operating Characteristics

Familiarization—Before mowing grass, practice operating the machine in an open area. Start and stop the engine. Operate in forward and reverse. When you feel familiar with the machine, practice operating around trees and obstacles. Also drive up and down slopes at different speeds.

WARNING

When operating a 4 wheel drive machine, always use the seat belt and Roll-Over Protection System together and have the seat pivot retaining pin installed.

Another characteristic to consider is the operation of the brake pedals. The brakes can be used to help turn the machine. However, use them carefully, especially on soft or wet grass because the turf may be torn accidentally. Another benefit of the brakes is to maintain traction. For example: When operating on a side hill, the uphill wheel slips and loses traction. If this situation occurs, depress the uphill brake pedal gradually and intermittently until the uphill wheel stops slipping, thus, increasing traction on the downhill wheel.

Warning System—If a warning light comes on during operation, stop the machine immediately and correct the problem before continuing operation. Serious damage could occur if the machine is operated with a malfunction.

Mowing—When you are at the area to be mowed, release the cutting unit transport latches. Move the axle shift lever rearward to Mow and the throttle to FAST so the engine is running at maximum speed. Lift the engagement switch and move forward to engage the cutting units.

Note: The cutting deck is equipped with a breakaway system to prevent wing decks from being damaged if a solid object is struck. If a wing deck strikes a solid object and unlatches from the center cutting deck, raise and lower the wing deck to reset in operating position.

Transport—When mowing is complete, disengage the cutting unit and raise it by pulling back on the cutting unit lift control levers. Hold the levers back until the cutting unit is fully raised. Never raise the cutting deck when engaged. Lock the cutting unit in place with transport latches. Move the axle shift lever forward to HI. When driving from one area to another, always shift the axle to LO before encountering a slope. Never shift from HI to LO while on a slope. Stop the

machine on a flat surface, engage the brakes and shift before climbing the slope. Be careful when driving between objects so you do not accidentally damage the machine or the cutting unit.

WARNING

The cutting deck breakaway system is equipped with a highly compressed spring. If spring removal or repair is required, contact your local authorized Toro Distributor for assistance.

Use extra care when operating the machine on slopes. Drive slowly and avoid sharp turns on slopes to prevent rollovers. The cutting unit must be lowered when going downhill for steering control.

Pushing Or Towing The Traction Unit—Use only a rigid tow bar if it becomes necessary to tow the machine. Make sure the axle shift lever is in NEUTRAL position and only tow the machine forward. Use trailer for normal transport. Move the axle shift lever to LO position before loading the machine on a trailer.

Operating Tips

Mow When Grass Is Dry—Mow either in the late morning to avoid the dew, which causes grass clumping or in late afternoon to avoid the damage that can be caused by direct sunlight on the sensitive, freshly mowed grass.

Select The Proper Height-of-cut Setting To Suit

Conditions—Remove approximately 2.5 cm (one inch) or no more than 1/3 of the grass blade when cutting. In exceptionally lush and dense grass you may have to raise your height-of-cut setting another notch.

Mowing In Extreme Conditions—Air is required to cut and re-cut grass clippings in the mower housing, so do not set the height-of-cut too low or totally surround the housing by uncut grass. Try to have one side of the mower housing free from uncut grass, allowing air to be drawn into housing. When making an initial cut through the center of an uncut area, operate the machine slower and back up if the mower starts to clog.

Clippings Discharge—Although the deck has rear discharge, some clippings are discharged toward the left side. To avoid

OPERATING INSTRUCTIONS

discharging undesirable clippings onto pathways, roads, or other non-turf surfaces, mow with the right side of the deck next to the pathway, road, or other non-turf surface

Mow At Proper Intervals—Under most normal conditions you'll need to mow every 4–5 days. But remember, grass grows at different rates at different times. This means that to maintain the same height of cut—which is a good practice—you'll need to cut more often in early spring; as the grass growth rate slows in mid summer, cut it only every 8–10 days. If you're unable to mow for an extended period, mow first with the height-of-cut at a high level; then mow again 2–3 days later with a lower height setting.

Always Mow With Sharp Blades—A sharp blade cuts cleanly and without tearing or shredding the grass blades. Tearing and shredding causes the grass to turn brown at the edges which impairs growth and increases susceptibility to diseases.

After Operating—To assure optimum performance, clean the underside of mower housings and under the belt covers after each use. If residue is allowed to build up in mower housings, cutting performance will decrease.

PROTOTYPE

MAINTENANCE

Greasing (Fig. 21–33)

The traction and cutting units have grease fittings that must be lubricated regularly with No. 2 General Purpose Lithium Base Grease. If the machine is operated under normal conditions, lubricate all grease fittings after every 25 hours of operation.

The grease fittings that must be lubricated are: Lift arm pivot (2), lift cylinder (2), brake arm pivots (2) (Fig. 21); brake pivot (1), brake pivots (2) (Fig. 22); traction pedal pivot (1) (Fig. 23); engine to pump drive shaft (2) (Fig. 24 & 25); traction adjuster (1) (Fig. 26); P.T.O. Bearing (Fig. 27).

2-Wheel drive machines only—cylinder end (2) center pivot (1), spindles (2) (Fig. 28).

4-Wheel drive machines only—tie rod assemblies (2), center pivot (1), axle knuckles (2) (Fig. 29); cylinder ends (2) (Fig. 30).

Cutting deck (2- & 4-wheel drive machines)—blade spindles (7) and Wing Deck Pivot pins (4) (Fig. 31); castor wheels (6); Castor fork shaft (4) (Fig. 32); Lift arm ball joints (2) and PTO to gear box drive shaft assembly (3) (Fig. 33).

1. Wipe grease fittings clean before lubricating.
2. Pump grease into fitting.
3. Wipe up excess grease.

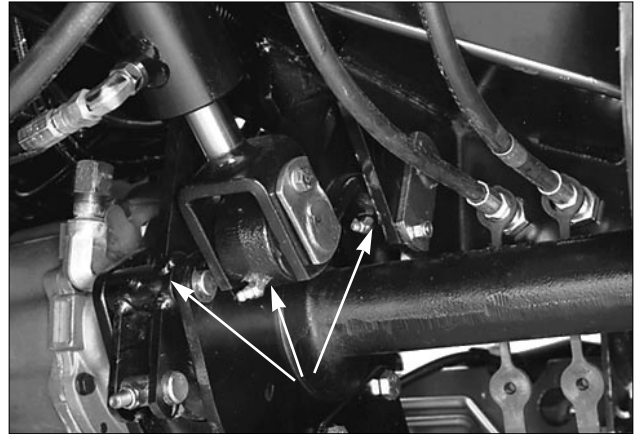

Figure 21

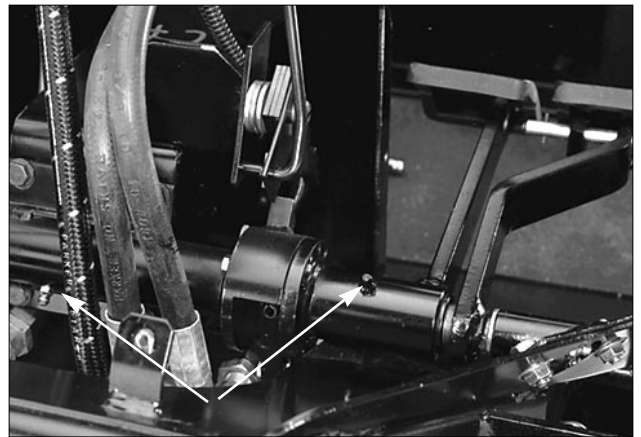

Figure 22



Figure 23

MAINTENANCE

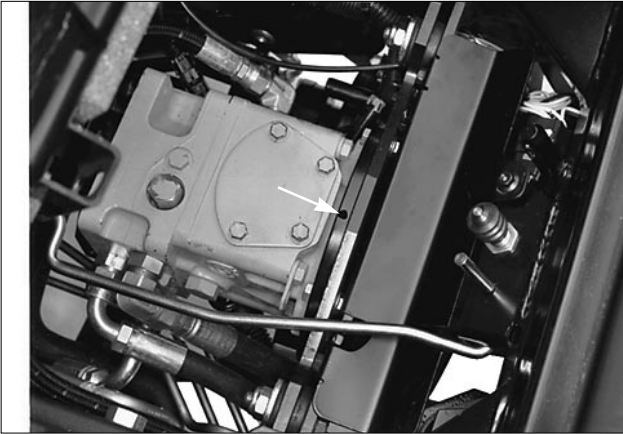

Figure 24

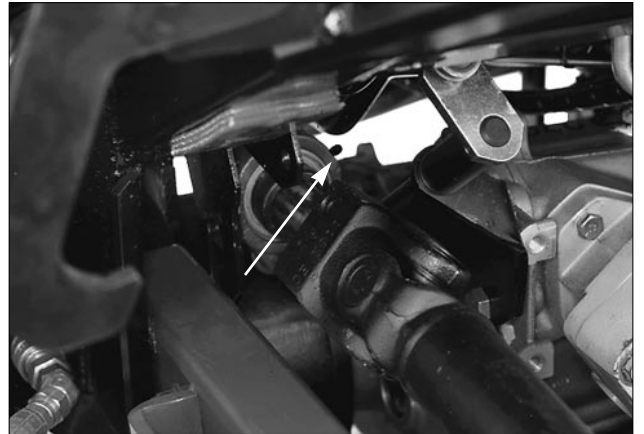

Figure 27



Figure 25



Figure 28

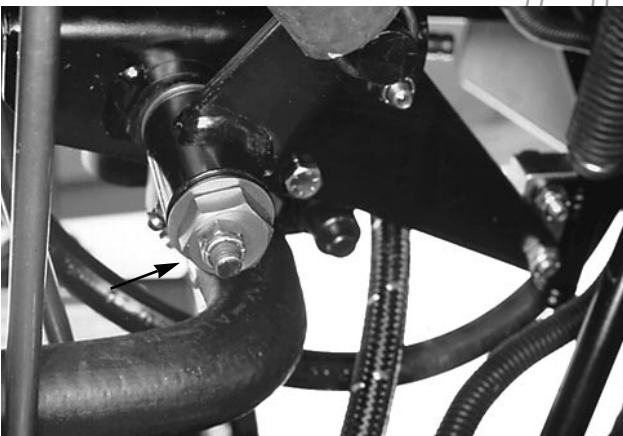

Figure 26

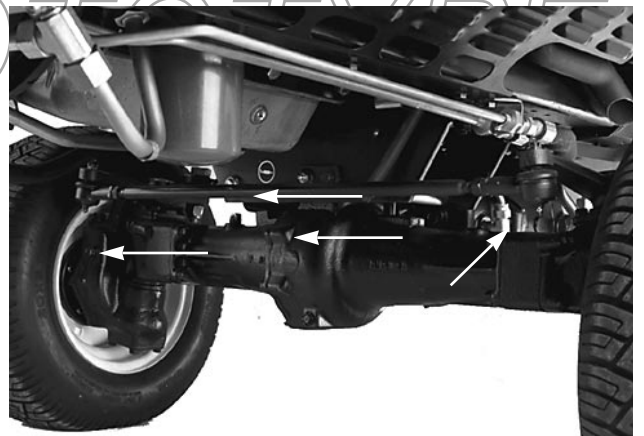

Figure 29

MAINTENANCE

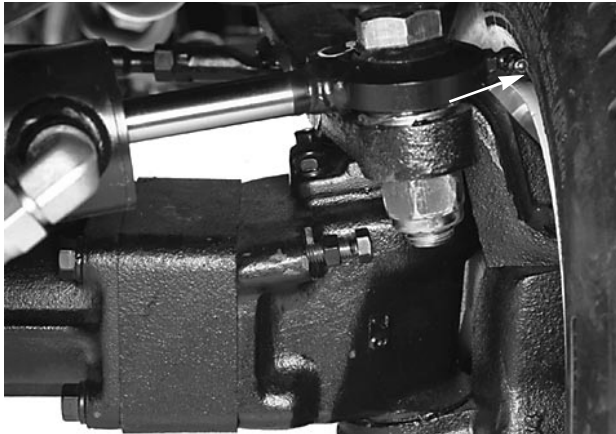

Figure 30



Fig. 33

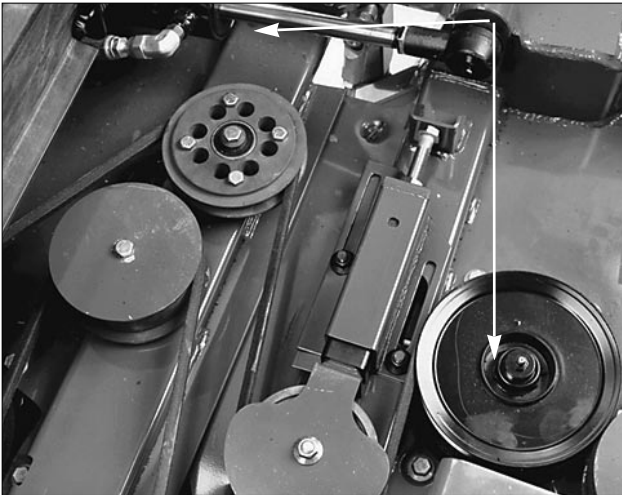

Fig. 31



Fig. 32

PROTOTYPE

MAINTENANCE

Adjusting The Traction Drive For Neutral (Fig. 34)

The machine must not creep when the traction pedal is released. If it does creep, an adjustment is required.

1. Park the machine on a level surface, shut the engine off and move shift lever to HI. Depress only the left brake pedal and engage the parking brake.
2. Jack up the right side of the machine until the front tire is off the shop floor. Support the machine with jack stands to prevent it from falling accidentally.
3. Under the left side of the machine, loosen the locknut on the traction adjustment cam.
4. Start the engine and rotate the cam hex in either direction until the wheel stops turning.

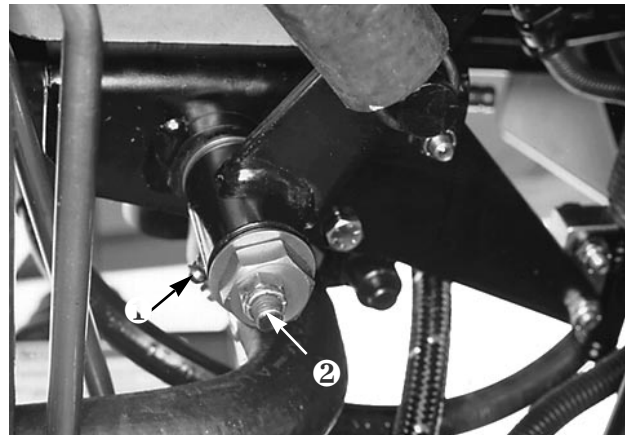

Figure 34

1. Traction adjustment cam
2. Locknut



WARNING

The engine must be running so that the traction cam can be adjusted. To guard against possible personal injury, keep your hands, feet, face and other body parts away from the muffler, other hot parts of the engine, and other rotating parts.

5. Tighten the locknut locking adjustment.
6. Stop the engine and release the right brake. Remove the jack stands and lower the machine to the shop floor. Test drive the machine to make sure it does not creep.

Safety Door Adjustment (Fig. 35)

On each side of the center deck is a safety door that opens and closes as the wing decks are lowered and raised (Fig. 35). The doors open to provide overlap of the cutting blades when the wing units are down. The doors close to provide safety and protection when the wing units are raised. Check to make sure the forward, lower edge of door (Fig. 35) is even or 6 mm (1/4 in.) higher than the lower edge of the door guide when the wing decks are in the fully raised, transport position. If an adjustment to the door is required, proceed as follows:

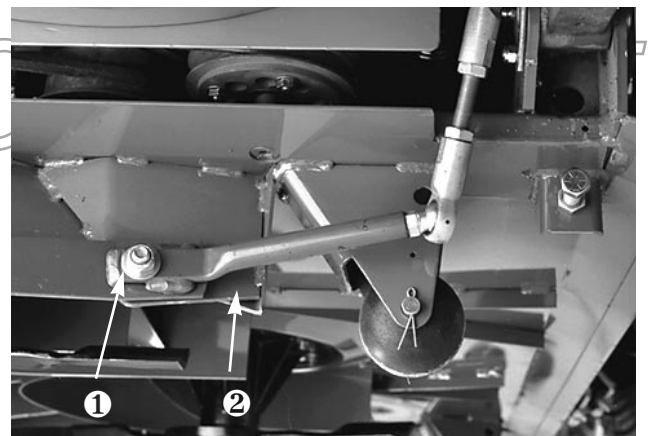

Figure 35

1. Safety door
2. Door guide

MAINTENANCE

1. Loosen the jam nuts securing the ball joints to the threaded rod.
2. Rotate the threaded rod to raise or lower the edge of door until it is even or 6 mm (1/4 inch) higher than the lower edge of door guide when the wing decks are in the fully raised, transport position.



CAUTION

Check for proper operation of the safety doors each time the deck is cleaned and repair as needed.

Maintenance	Interval	Figure Number	Specifications
Inspect air filter dust cup and baffle	Once a week or every 50 hours operation. Daily or more if conditions are extremely dusty or dirty	36	
Clean air cleaner filter.	Every 250 hours or more often in extremely dusty or dirty conditions. Replace filter after six cleanings (1500 hours) or annually, whichever comes first.	36	
Change engine oil	After 50 hours of operation	37	
Change oil filter	After first 50 hour of operation and every 100 hours after that.	38	
Check fuel lines	Every 400 hours or yearly, whichever comes first.		Inspect for deterioration, damage or loose connections
Drain fuel filter and water separator	Daily	39	
Change fuel filter	Every 400 hours or annually, whichever comes first	39	
Clean radiator screen, oil cooler and radiator	Daily; more often in dirty conditions	40, 41	Remove debris
Maintain cooling system	After every 100 operating hours tighten hose connections; After every 2 years, drain and flush the cooling system		50/50 solution of water and Peugeot-recommended antifreeze.
Engine fan belt	Check often. Replace after every 800 hours of operation	42	Proper tension allows #1/4 in. deflection on belt when it is pressed midway between the pulleys.
Hydraulic oil	After every 500 operating hours.	43, 44	
Hydraulic filter	After the first 50 operating hours, thereafter, every 500 operating hours.	45	
Hydraulic lines and hoses	After every 100 operating hours		

MAINTENANCE

Maintenance	Interval	Figure Number	Specifications
Change front and rear axle lubricant	After every 500 operating hours	46, 47	
Check rear wheel toe-in	After every 800 operating hours	48	
Adjust PTO belt	Check frequently. Replace after every 1,500 operating hours.	49, 50	
Adjust PTO clutch	Check adjustment after every 250 operating hours.	51	Correct disengaged clearance between the clutch plates is .011–.021
Check battery	Check after every 50 hours of operation.		Wash entire area with a solution of baking soda and water. Coat the battery posts and cable connectors with Grafo 112X (Skin over) grease.
Fuses		52	<ol style="list-style-type: none"> 1. Accessory: 5 amp 2. Relay: 5 amp 3. Deck: 30 amp 4. Run: 15 amp
Adjust cutting unit belt tension	Check adjustment of idler after the first 10 hours of operation and every time maintenance is done on the blade belt.	53, 54	There should be 3.4 in.# between the edge of the idler support and the center of the idler pulley.
Check belt deck clutches	Check clutch adjustment after every 250 hours of operation.	55	Correct clearance between clutch plates is .011–.021 inches#.

3. Tighten the jams nuts to lock the adjustment.

Adjust cutting unit belt tension

Fuses (Figure 52)

1. Accessory: 5 amp
2. Relay: 5 amp
3. Deck: 30 amp
4. Run: 15 amp

Check adjustment of idler after the first 10 hours of operation and every time maintenance is done on the blade belt (Figure 53, 54). There should be 3.4 in. between the edge of the idler support and the center of the idler pulley.

Check belt deck clutches. Check clutch adjustment after every 250 hours of operation (Figure 55). Correct clearance between clutch plates is .011–.021 inches.

MAINTENANCE

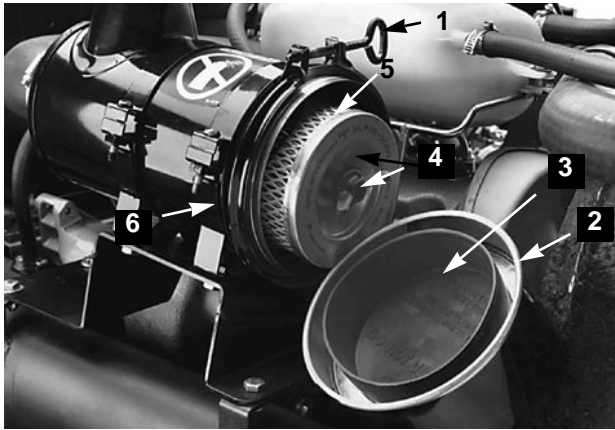

Figure 36

- | | |
|----------------|----------------------|
| 1. Thumb screw | 4. Wing nut & Gasket |
| 2. Dust Cup | 5. Filter element |
| 3. Baffle | 6. Air cleaner body |

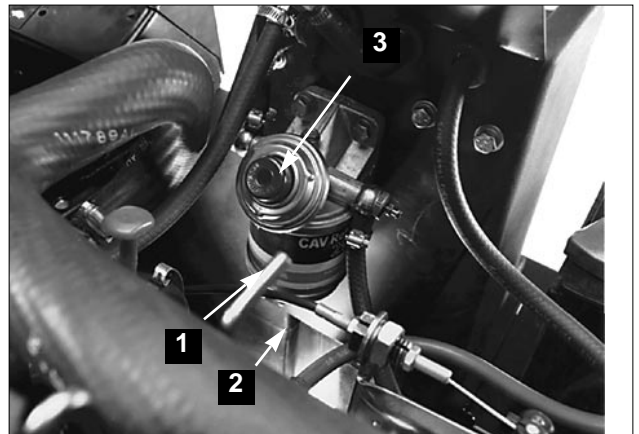

Figure 39

- | | |
|--------------------------------|-------------------|
| 1. Fuel filter/Water separator | 3. Primer plunger |
| 2. Drain screw | |

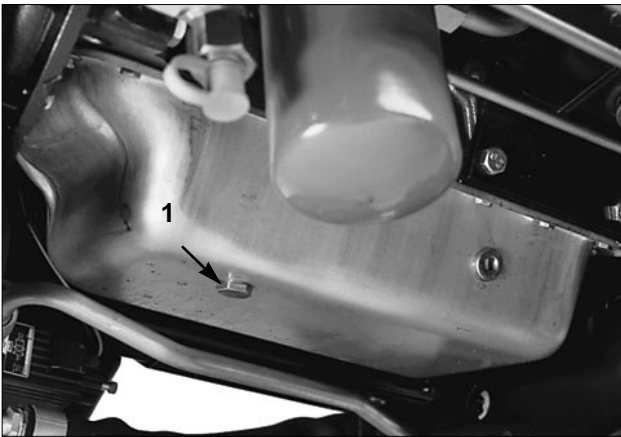

Figure 37

1. Drain plug



Figure 40

1. Rear radiator screen

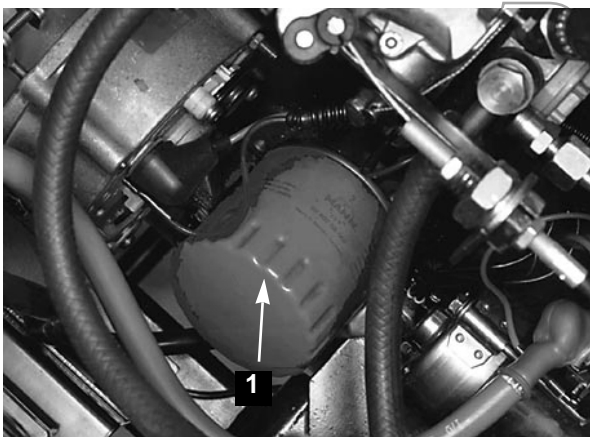

Figure 38

1. Oil Filter

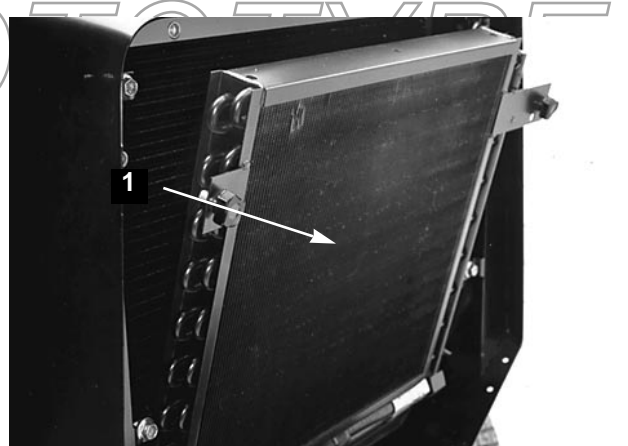

Figure 41

1. Radiator

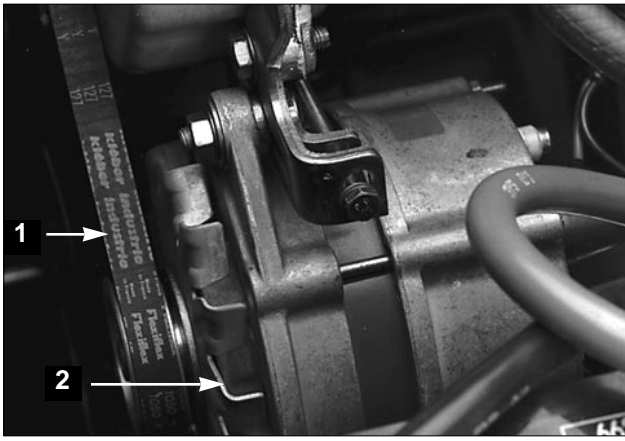

Fig. 42

- 1. Fan belt
- 2. Adjusting screw

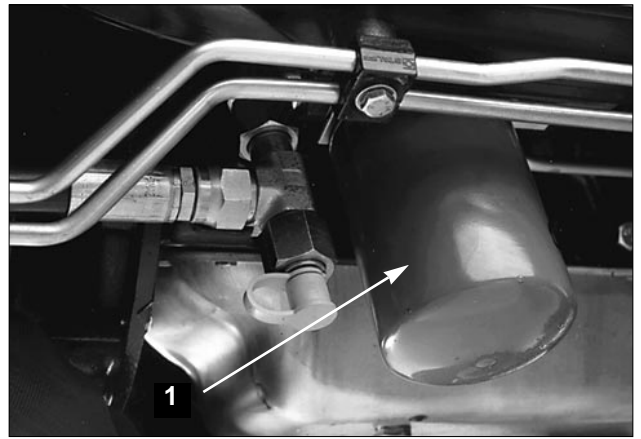

Fig. 45

- 1. Hydraulic filter

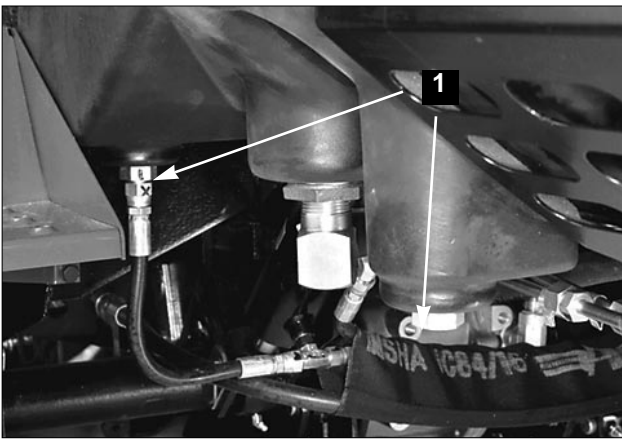

Fig. 43

- 1. Hydraulic reservoir drain

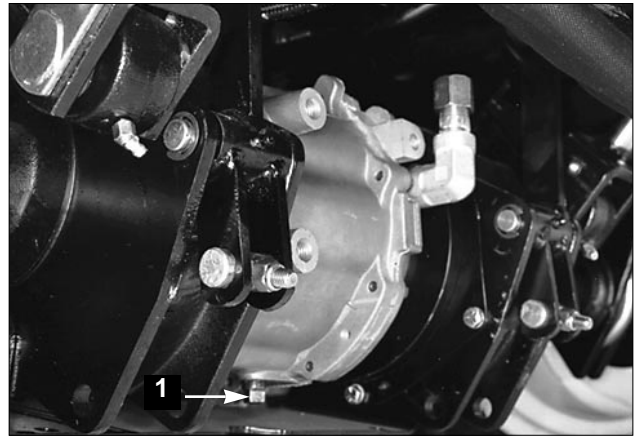

Fig. 46

- 1. Front axle drain plug

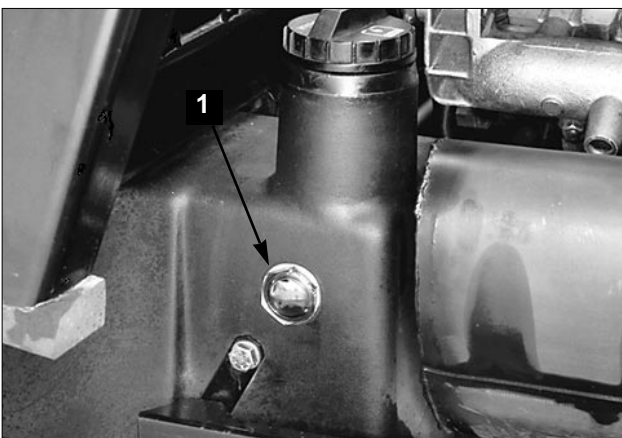

Fig. 44

- 1. Sight gauge

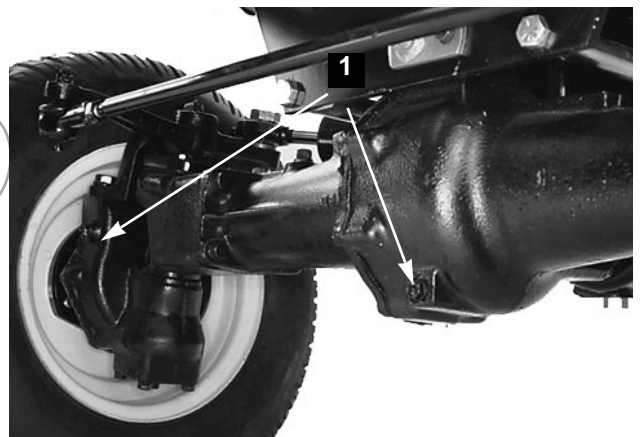

Fig. 47

- 1. Drain plugs (3)



Fig. 48

- 1. Tie rod clamps

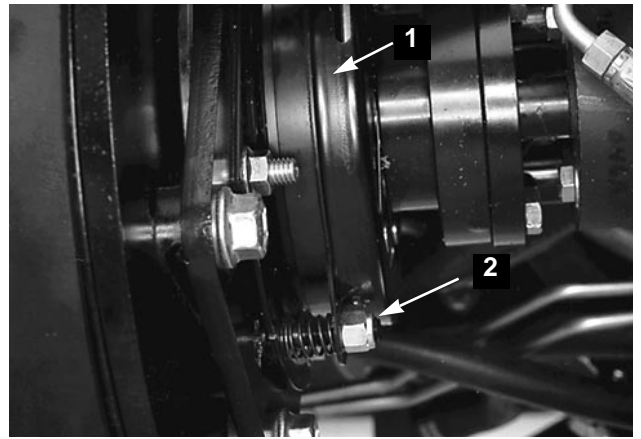

Fig. 51

- 1. Clutch
- 2. Flange studs

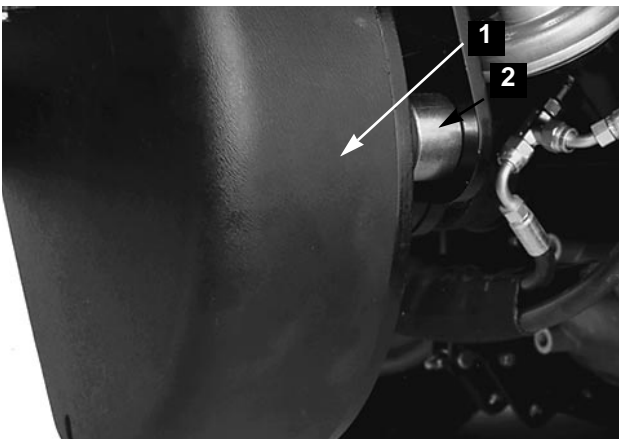

Fig. 49

- 1. P.T.O. belt cover
- 2. Adapter plate

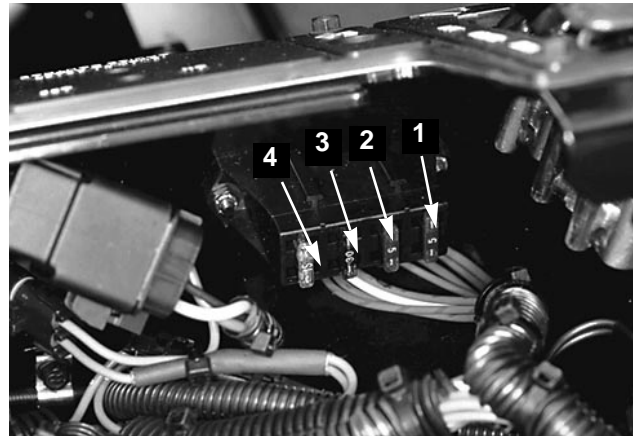

Fig. 52

- 1. Accessory fuse
- 2. Relay fuse
- 3. Deck fuse
- 4. Run Fuse

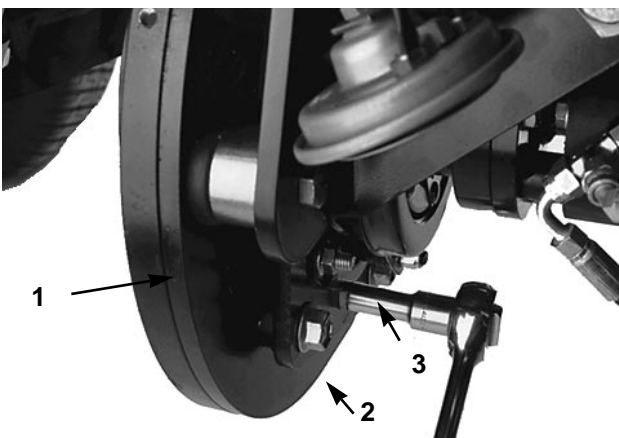

Fig. 50

- 1. P.T.O. belt cover
- 2. Adapter plate
- 3. Square hole

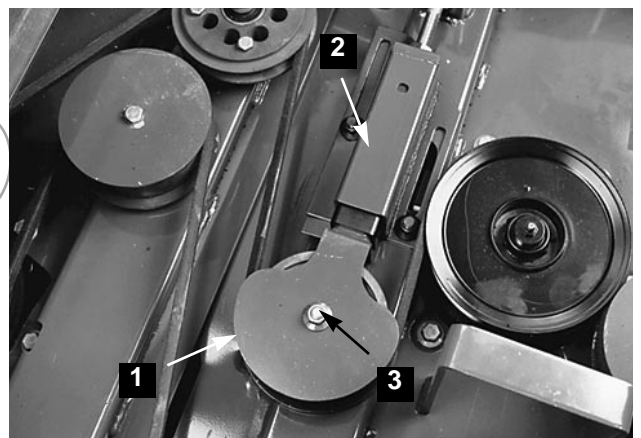

Fig. 53

- 1. Spring-loaded idler
- 2. Idler support
- 3. Center of idler pulley

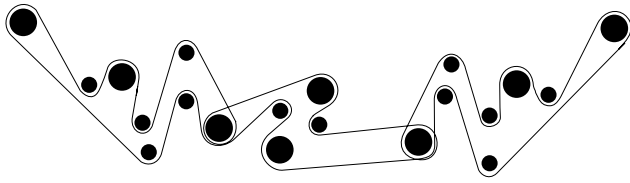

Fig. 54
Belt Routing

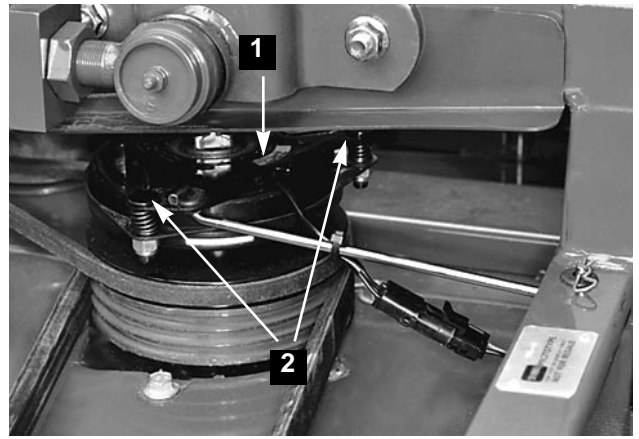

Fig. 55
1. Clutch
2. Flange studs

PREPARATION FOR SEASONAL STORAGE

Traction Unit

1. Thoroughly clean the traction unit, cutting units and the engine.
2. Check the tire pressure. Inflate all tires to 138 kPa (20 psi).
3. Check all fasteners for looseness; tighten as necessary.
4. Grease or oil all grease fittings and pivot points. Wipe up any excess lubricant.
5. Lightly sand and use touch-up paint on painted areas that are scratched, chipped, or rusted. Repair any dents in the metal body.
6. Service the battery and cables as follows:
 - a. Remove the battery terminals from the battery posts.
 - b. Clean the battery, terminals, and posts with a wire brush and baking soda solution.
 - c. Coat the cable terminals and battery posts with Grafo 112X skin-over grease every 60 days for 24 hours to prevent lead sulfation of the battery.

Engine

1. Drain the engine oil from the oil pan and replace the drain plug.
2. Remove and discard the oil filter. Install a new oil filter.
3. Refill the oil pan with 5.3 quarts of SAE10W-30 CD motor oil.
4. Start the engine and run at idle speed for approximately two minutes.
5. Stop the engine.
6. Flush the fuel tank with fresh, clean diesel fuel.
7. Re-secure all fuel system fittings.
8. Thoroughly clean and service the air cleaner assembly.
9. Seal the air cleaner inlet and the exhaust outlet with weatherproof tape.
10. Check anti-freeze protection and add a 50/50 solution of water and Peugeot recommended anti-freeze as needed for expected minimum temperature in your area.

Cutting Unit

1. Check the blades and tighten the blade bolts to 115–149 Nm (85–110 ft-lb.)
2. Check and lubricate caster arm bushings.
3. Check and lubricate the caster wheel bearings. Tighten the caster wheel nuts to 190–224 Nm (140–165 ft-lb).
4. Check all fasteners for looseness; tighten as necessary.
5. Grease or oil all grease fittings and pivot points. Wipe up any excess lubricant.
6. Lightly sand and use touch-up paint on painted areas that are scratched, chipped, or rusted.
7. Check the drive belts.
8. Clean thoroughly the top and underside.

PROTOTYPE

PROTOTYPE



PROTOTYPE