



MODEL NO. 03505—60001 & UP

MODEL NO. 03508—60001 & UP

OPERATOR'S
MANUAL

REELMASTER® 5100 CUTTING UNIT



PROTOTYPE

Table of Contents

	Page No.		Page No.
SPECIFICATIONS	2	BACKLAPPING CUTTING UNITS	5
ADJUSTING THE CUTTING UNIT	3	LUBRICATION	6
Adjusting Bedknife to Reel	3	MAINTENANCE	6
Adjusting Shield Height	3	Removing Bedknife For Grinding	7
Adjusting Top Bar	4	Preparing Reel for Grinding	7
Leveling Front Roller to Reel	4	Servicing and Adjusting Reel Bearings	7
Adjusting Height of Cut	5	Removal of Reel Assembly	7

Specifications

REEL CONSTRUCTION: 5 or 8 blades riveted to 5 cast spiders.

HEIGHT OF CUT RANGE:

5 Blade— $\frac{1}{2}$ – $\frac{3}{4}$ (1.3–1.9 cm)

8 Blade— $\frac{1}{4}$ – $\frac{5}{8}$ (0.7–1.7 cm)

REEL DIAMETER: 5 in.(12.7 cm)

POWER: Hydraulic motor splined to reel shaft.

BEARINGS: Timken tapered roller.

BEDKNIFE AND BEDBAR ADJUSTMENT: Opposing screw .

ROLLER ADJUSTMENT:

Front: Fixed

Rear: Screw adjustable with bolt clamp lock

Adjusting The Cutting Unit

IMPORTANT: Read this Operator's Manual thoroughly before operating cutting unit. Failure to do so may result in damage to the cutting unit.

NOTE: The cutting units are shipped completely assembled. Two flange lock nuts, shipped loose with each cutting unit are used to mount the reel drive motor to the cutting unit. Retain these fasteners for later installation.

After the cutting unit is unboxed, use the following proce-

dures to assure the cutting units are adjusted properly .

1. Check for looseness in the bearings between the end plate and reel. Check looseness of bearings by moving the reel laterally or axially on each end of cutting unit; refer to section on *Servicing And Adjusting The Reel Bearings*.
2. Check the drive end of the reel for grease. Grease should be visibly evident.

3. Insure that all nuts and bolts are securely fastened.
4. Check the level of the front roller to the reel; refer to the section on *Leveling the Front Roller Assembly to the Reel*.

ADJUSTING THE BEDKNIFE TO THE REEL

1. First, loosen the bottom screw on each side of the cutting unit (Fig. 1), then tighten the top adjustment screw on each side of the cutting unit. This adjustment will position the bedknife closer to the reel blades.



Figure 1

1. Bottom bedknife adjusting screw
2. Top bedknife adjusting screw

IMPORTANT: Use only a $\frac{5}{8}$ -inch open end wrench 3–6 inches in length for adjusting bedknife to reel. A longer wrench will provide too much leverage and may distort the mounting plate for the adjustment screw.

2. After adjusting the bedknife to the reel, make sure that both the top and the bottom adjustment screws are secured on both ends of the cutting unit (Fig. 1).
3. After the adjustment, check to see if the reel can pinch paper when it is inserted from the front and also cut paper when inserted at a right angle (Fig. 2). It should be possible to cut paper with minimum contact between the bedknife and the reel blades. Should excessive reel drag be evident, it will be necessary to either back lap or regrind the cutting unit to achieve the sharp edges needed for precision cutting (see Toro

reel sharpening manual).

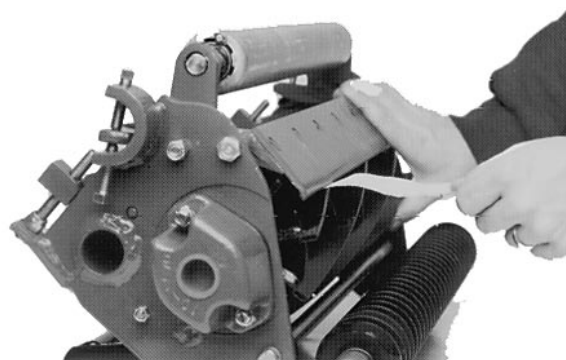

Figure 2

ADJUSTING SHIELD HEIGHT

Adjust the shield to assure proper grass clipping discharge into the basket or for desired front discharge when not using baskets.

1. Set the cutting unit in normal cutting position. (Fig 3).

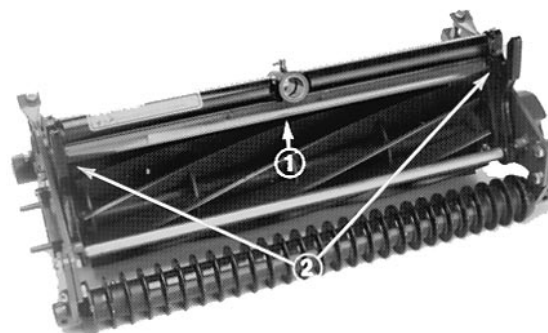

Figure 3

1. Shield
2. Shield fasteners

2. Loosen the capscrews and nuts securing the shield to each side-plate, adjust the shield to the desired height and tighten the fasteners (Fig. 3).
3. Repeat adjustment on the remaining cutting units and adjust the top bar; refer to the section on *Adjusting the Top Bar*.

When mowing in conditions in which excessive amounts of clippings are being removed, rear discharge may be desirable. Opening the rear shield will allow direct discharge of clippings, thus preventing

recutting .

To open the rear shield:

1. Loosen the locking bolt on the side of the cutting unit (Fig. 4).

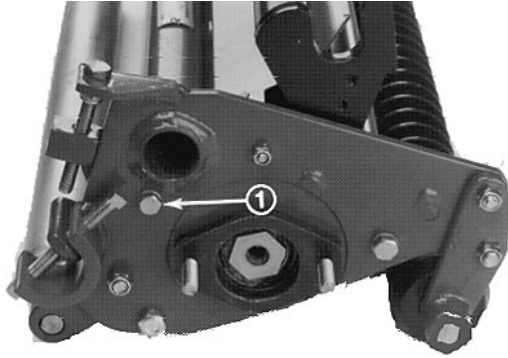

Figure 4

1. Rear shield locking bolt

1. Open the rear shield to the desired operating position.
2. Tighten the locking bolt to secure shield.

ADJUSTING THE TOP BAR

Adjust the top bar to assure clippings are cleanly discharged from reel area:

1. Loosen screws securing the top bar (Fig. 5). Insert a 0.060-inch feeler gauge between the top of the reel and the bar and tighten the screws (Fig. 5). Assure the bar and reel are equal distance apart across the complete reel.
2. Repeat the settings on the remaining cutting units.

NOTE: The bar is adjustable to compensate for changes in turf conditions. It should be parallel to the reel to assure optimum performance and should be adjusted whenever the shield height is adjusted or whenever the reel is sharpened on a reel grinder.

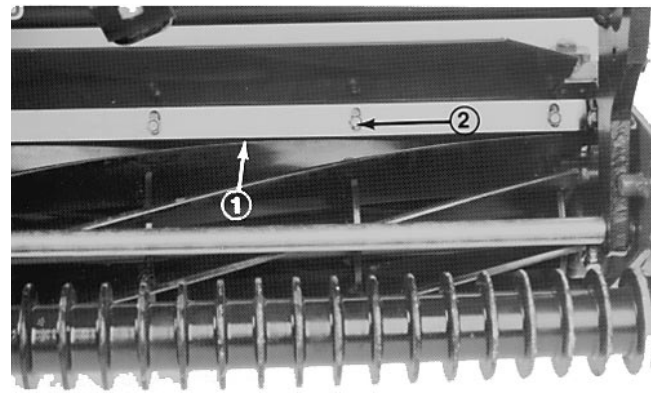

Figure 5

1. Top bar
2. Bar mounting screws

LEVELING THE FRONT ROLLER TO THE REEL

1. Adjust the rear roller assembly to the lowest height-of-cut; refer to the section on *Adjusting the Height of Cut*. Do not tighten nuts securing height-of-cut brackets at this time.
2. Place a 1/4 inch or thicker plate under the reel blades and against the cutting edge of the bedknife (Fig. 6). The rear roller should not contact the surface.

NOTE: Be sure the plate covers the full length of the reel blades.

3. Level the front roller to the reel by loosening the (4) capscrews holding the front roller brackets and rotating front roller until it contacts the surface the plate is on. Tighten the capscrews and make sure the roller has not changed position. To prevent moving the roller bracket when tightening, hold the nut and tighten the capscrew.
4. With the cutting unit reel blades positioned on the plate, hold cutting unit securely and turn tap bolts until the rear roller assembly contacts the working surface across the full length of the roller.

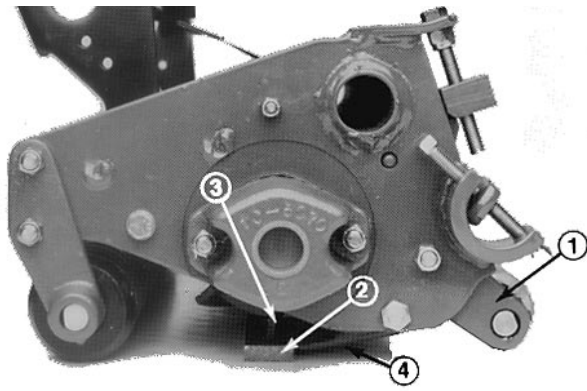

Figure 6

- | | |
|-------------------------|----------------|
| 1. Rear roller bracket | 3. Reel blades |
| 2. 1/4 inch steel plate | 4. Bedknife |

NOTE: This adjustment should be made on a flat working surface.

- Secure the nut on the outside of the rear roller height-of-cut bracket to lock the roller in position.

ADJUSTING THE HEIGHT OF CUT

- The front roller must be leveled first; refer to section on *Leveling The Front Roller To The Reel*.
- To adjust the height of cut, the cutting unit should be turned over.
- Loosen the locknuts securing the height of cut brackets to each end of the cutting unit (Fig. 7).

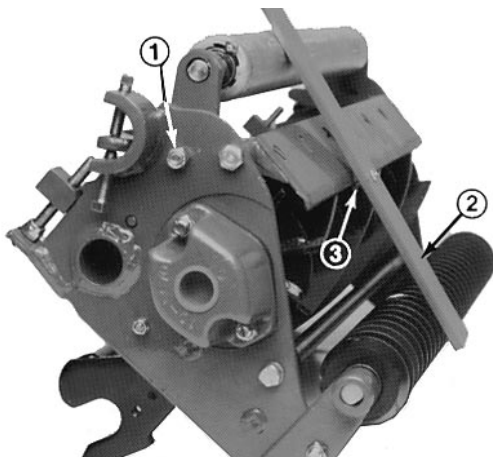

Figure 7

- Locknut
- Gauge bar
- Gauge bar screw head

- Set the head of the screw on the gauge bar to the

desired height of cut, making this measurement from the bar face to the underside of the screw head.

- Place the bar across the front and rear rollers and adjust the tap bolt until the underside of the screw head engages the bedknife cutting edge (Fig. 7).

IMPORTANT: Do procedure No. 4 on each end of the bedknife. Tighten height of cut adjustment locknuts on both ends. Recheck adjustment.

BACKLAPPING CUTTING UNITS

DANGER

Reels may stall while backlapping. Do not attempt to restart reels by hand or adjust them while backlapping. Set the speed control to position 11 to start the reels; set to position 1 for backlapping

NOTE: Backlap either the front cutting units together or the rear ones together.

- Position the machine on a clean, level surface, lower the cutting units, stop the engine, engage the parking brakes, move enable/disable switch to the disable position and remove the key from the ignition switch.
- Unlock and raise the seat to expose the controls.
- Make the initial reel-to-bedknife adjustments appropriate for backlapping on all cutting units. Start the engine and set the engine at idle speed.
- Set both reel speed controls to position 11. Select either the front or rear on the backlap switch to determine which units to backlap.
- Move the enable/disable switch to the enable position. Move the lower mow/raise lever forward to start backlapping operation on designated reels.
- For the cutting units being backlapped, move the reel speed control to position 1.
- Apply lapping compound with the long-handled brush supplied with machine.



CAUTION

Be careful when lapping the reel because contact with the reel or other moving parts can result in personal injury.

8. To make an adjustment to the cutting units while backlapping, turn the reels OFF by moving the Lower Mow/Raise lever REARWARD, Move the Enable/Disable switch to DISABLE and turn the engine OFF. After adjustments have been completed, repeat steps 3–7.
9. Repeat the procedure for remaining cutting units.
10. When the backlap operation is completed, return the backlap switch to OFF, set the reel speed controls to the desired mowing setting and wash all lapping compound from the cutting units.

NOTE: Additional instructions and procedures on Backlapping are available in the TORO Sharpening Reel & Rotary Mowers Manual Form No. 80—300PT.

NOTE: For a better cutting edge, run a file across the front face of the bedknife when the lapping operation is completed. This will remove any burrs or rough edges that may have built up on the cutting edge.

LUBRICATION

There are six (6) grease fittings on each cutting unit (Fig. 8, 9), which must be lubricated using a No. 2 multi-purpose lithium base grease. A hand-operated grease gun is recommended for best results.

IMPORTANT: Lubricating cutting units immediately after washing helps purge water out of bearings and increases bearing life.

1. Wipe each grease fitting with a clean cloth.

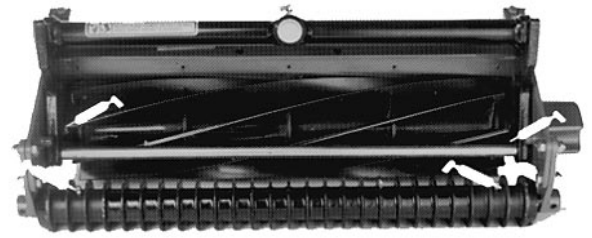

Figure 8

2. Grease reel bearings as follows:
 - A. Hydraulic motor end: apply grease until pressure is felt against the handle.
 - B. Counterbalance end: apply grease until it starts to come through the seal inside the counter balance hole.
 3. Apply grease to the front and rear roller bearings until it begins to show around washers, on rear rollers or seal lips, on front rollers.
- IMPORTANT: Do not apply too much pressure or the grease seals will be permanently damaged.**
4. Wipe excess grease away.



Figure 9

MAINTENANCE

IMPORTANT: Reel motors must be removed before removing the cutting units to prevent hose damage due to twisting, bending, and kinking.

REMOVING THE BEDKNIFE FOR GRINDING

The rear roller assembly must be removed to remove the bedknife assembly for sharpening. To remove the rear roller, proceed as follows:

1. Remove the capscrew and nut anchoring the rear roller height-of-cut bracket to the side plate on both ends of the cutting unit (Fig. 10).
2. Loosen set screws securing the rear roller shaft to the height-of-cut brackets.

IMPORTANT: When reinstalling THE rear roller shaft to the height-of-cut brackets, torque THE set screws to 34–40 Nm (25-30 ft. lb).

3. Unthread the tap bolts from the height-of-cut brackets and remove the from both side plates.
4. Remove the bedbar mounting bolts from each end of the cutting unit (Fig. 10). Then loosen the bedknife adjusting screws at each end of the cutting unit (Fig. 10). The bedknife assembly can then be removed by rotating it away from the reel.

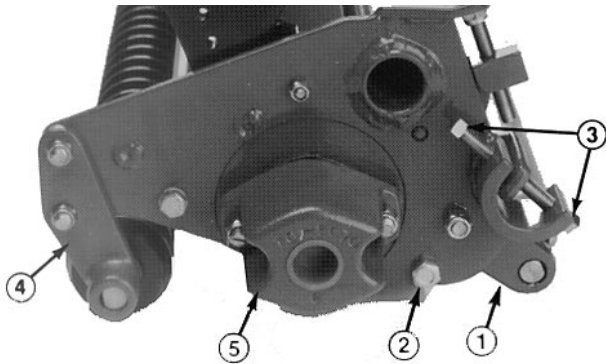

Figure 10

1. Rear Roller Height of Cut Bracket
2. Bedbar Mounting Bolts
3. Bedknife Adjusting Screws
4. Front Roller Brackets
5. Counterbalance End Cap

IMPORTANT: When reinstalling the bedbar assembly, be sure to assemble the rear roller brackets under the arms of bedbar

NOTE: For proper grinding of bedknife, grind in accordance with procedures in the TORO Sharpening

PREPARING THE REEL FOR GRINDING

The front roller may have to be removed so that the reel can be sharpened. To accomplish this, proceed as follows:

IMPORTANT: Some reel grinders may require that the rear roller assembly be mounted to the cutting unit for proper support in the reel grinder.

1. Remove the locknuts securing the front roller brackets to the side plates at both ends of the cutting unit (Fig. 10).
2. The roller assembly can then be removed from the cutting unit by pulling evenly on both sides.
3. For proper grinding of reel, grind in accordance with procedures in TORO *Sharpening Reel & Rotary Mowers Form No. 80-300PT.*

IMPORTANT: After grinding operation is complete, assemble cutting unit, check bearing adjustment and adjust THE top shield and bar; refer to sections on Adjusting Shield Height and Adjust Top Bar. Back lap the cutting unit to complete sharpening operation. To assure proper alignment of the rear roller in the roller brackets, make sure the roller moves freely within the brackets before tightening the set screws on bearing shafts. Apply medium-strength Locktite #242 to set the screws before tightening.

SERVICING AND ADJUSTING THE REEL BEARINGS

IMPORTANT: Before removing the cutting unit, remove reel motors to prevent damaging hydraulic hoses.

Check periodically the drag on the reel bearings. Proper adjustment of the reel bearings insures that no end play of the reel exists and there is minimum rolling torque of reel assembly. All measurements and adjustments of reel rolling torque must be done with a completely assembled cutting unit. The reel bearings can be checked and adjusted in the following manner:

1. First, adjust the bedknife so it is not in contact with the reel.
2. The rolling torque required to turn the reel should be 4 to 7 inch pounds. This should be measured with a torque wrench.

If the rolling torque of the reel is not per specification or end play of reel exists, adjust the reel bearing as follows:

- A. Remove the mounting nuts from the counterbalance end cap and remove end cap from the mounting studs (Fig. 10).
- B. Using a large socket wrench, remove the reel bearing adjustment nut. Tap on the head of the hex head bolt on the end of the reel shaft, with a small hammer, until end play of the reel can be felt.
- C. Hold the reel from turning and slowly tighten the reel bearing adjustment nut until no end play of the reel exists.
- D. Using an appropriate torque wrench, check the rolling torque of the reel. The rolling torque of the reel should be 4 to 7 in. lb. Check to make sure no end play exists and reel spins freely.

IMPORTANT: Before removing cutting unit, remove reel motors to prevent damaging hydraulic hoses.

- E. Reinstall the counterbalance end cap.

REMOVAL OF REEL ASSEMBLY

1. Remove the front roller assembly.
2. Remove the counterbalance end cap (Fig. 10).
3. Remove the large bearing adjustment nut from the counterbalance end of the reel shaft and the special spline nut (Fig. 11) at the opposite end of the reel shaft.
4. Remove the mounting bolts from the bearing housing on both ends of the cutting unit.

IMPORTANT: Remove grease fittings from the bearing housing at each end of the cutting unit. Note that the 45° fitting is on the right end, and the 90° fitting at the left end (when viewed in the direction of travel).

5. Using a plastic headed hammer, rotate the bearing housing slightly, install the bearing housing bolts from outside housing, turn the bolts alternately against side plate, and use this method to remove the bearing housing.
6. The bearing housing will slip out of the side plates and the reel assembly can be removed as soon as the bearing housings are disassembled from the side plates.

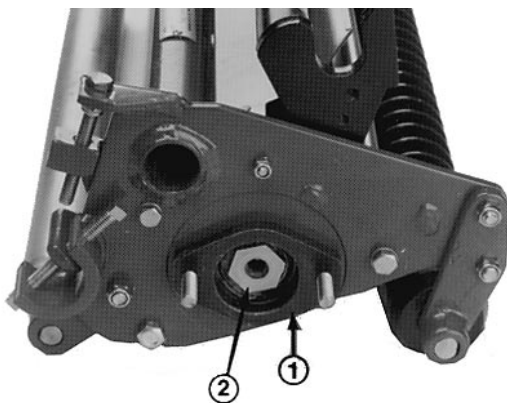

figure 11

1. Reel Bearing Housing
2. Splined Nut

PHOTOTYPE