



**Count on it.**

**Operator's Manual**

# TimeCutter® SW 3200 Riding Mower

Model No. 74780—Serial No. 40000000 and Up

Model No. 74781—Serial No. 40000000 and Up

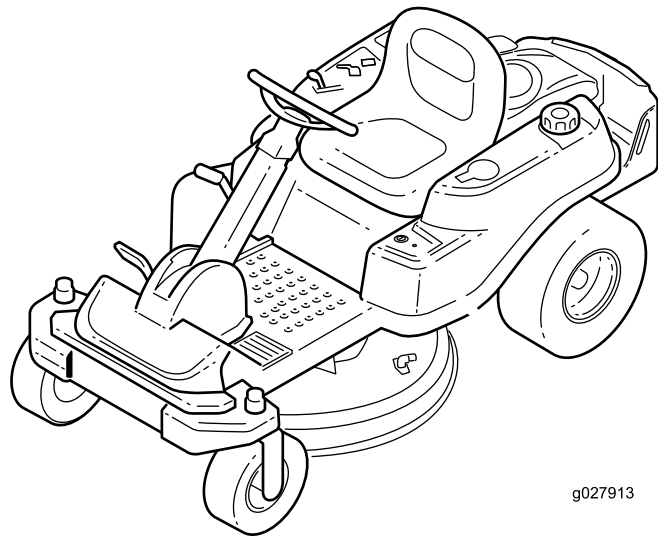

g027913



## ⚠ WARNING

### CALIFORNIA Proposition 65 Warning

This product contains a chemical or chemicals known to the State of California to cause cancer, birth defects, or reproductive harm.

The engine exhaust from this product contains chemicals known to the State of California to cause cancer, birth defects, or other reproductive harm.

This spark ignition system complies with Canadian ICES-002

It is a violation of California Public Resource Code Section 4442 or 4443 to use or operate the engine on any forest-covered, brush-covered, or grass-covered land unless the engine is equipped with a spark arrester, as defined in Section 4442, maintained in effective working order or the engine is constructed, equipped, and maintained for the prevention of fire.

### Gross Horsepower

The gross or net horsepower of this engine was laboratory rated by the engine manufacturer in accordance with the Society of Automotive Engineers (SAE) J1940. As configured to meet safety, emission, and operating requirements, the actual engine torque on this class of mower will be significantly lower.

Go to [www.Toro.com](http://www.Toro.com) to view specifications on your mower model.

## Introduction

This machine is a ride-on, rotary-blade lawn mower intended to be used by homeowners in residential applications. It is primarily designed for cutting grass on well-maintained lawns. It is not designed for cutting brush, mowing grass and other growth alongside highways, or for agricultural uses.

Read this information carefully to learn how to operate and maintain your product properly and to avoid injury and product damage. You are responsible for operating the product properly and safely.

You may contact Toro directly at [www.Toro.com](http://www.Toro.com) for product safety and operation training materials, accessory information, help finding a dealer, or to register your product.

Whenever you need service, genuine Toro parts, or additional information, contact an Authorized Service Dealer or Toro Customer Service and have the model and serial numbers of your product ready. [Figure 1](#) identifies the location of the model and serial numbers on the product. Write the numbers in the space provided.

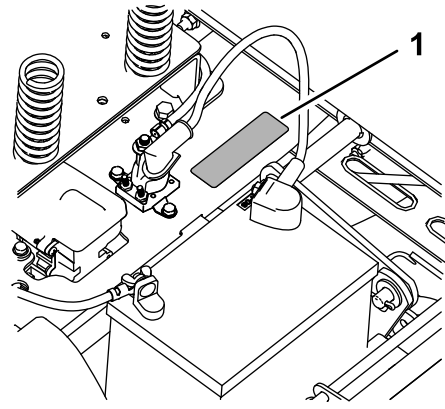

g188142

**Figure 1**  
Under the seat

1. Model and serial number plate

Write the product model and serial numbers in the space below:

<b>Model No.</b> _____
<b>Serial No.</b> _____

This manual identifies potential hazards and has safety messages identified by the safety-alert symbol ([Figure 2](#)), which signals a hazard that may cause serious injury or death if you do not follow the recommended precautions.



g000502

**Figure 2**

1. Safety-alert symbol.

This manual uses 2 words to highlight information.

**Important** calls attention to special mechanical information and **Note** emphasizes general information worthy of special attention.

# Contents

Safety .....	4	Drive System Maintenance .....	35
General Safety.....	4	Checking the Tire Pressure .....	35
Slope Indicator .....	5	Releasing the Electric Brake .....	35
Safety and Instructional Decals .....	6	Mower Maintenance.....	36
Product Overview .....	10	Servicing the Cutting Blades.....	36
Controls .....	10	Leveling the Mower Deck.....	38
Before Operation .....	12	Removing the Mower Deck .....	39
Before Operation Safety.....	12	Installing the Mower Deck.....	40
Recommended Fuel.....	12	Replacing the Grass Deflector.....	40
Using Stabilizer/Conditioner .....	12	Mower Belt Maintenance .....	41
Filling the Fuel Tank .....	13	Inspecting the Belts .....	41
Checking the Engine-Oil Level.....	13	Replacing the Mower Belt.....	41
Breaking in a New Machine.....	13	Cleaning .....	42
Think Safety First.....	13	Cleaning under the Front of the Machine .....	42
Using the Safety-Interlock System.....	15	Washing the Underside of the Mower .....	42
Positioning the Seat .....	16	Storage .....	43
Positioning the Steering Wheel .....	16	Cleaning and Storage .....	43
During Operation .....	16	Troubleshooting .....	45
During Operation Safety .....	16	Schematics .....	47
Operating the Smart Park™ Parking Brake.....	17		
Operating the Mower Blade-Control Switch (PTO) .....	17		
Operating the Throttle .....	18		
Operating the Ignition Switch .....	18		
Starting and Shutting Off the Engine.....	19		
Driving the Machine .....	19		
Stopping the Machine .....	20		
Mowing in Reverse .....	20		
Adjusting the Height of Cut.....	20		
Using the Grass Deflector .....	21		
Operating Tips .....	21		
After Operation .....	22		
After Operation Safety.....	22		
Pushing the Machine by Hand.....	22		
Transporting the Machine.....	23		
Loading the Machine .....	23		
Maintenance .....	25		
Recommended Maintenance Schedule(s) .....	25		
Pre-Maintenance Procedures .....	25		
Maintenance and Storage.....	25		
Raising the Seat.....	26		
Raising the Front of the Machine .....	26		
Lubrication .....	27		
Greasing the Bearings .....	27		
Engine Maintenance .....	27		
Engine Safety.....	27		
Servicing the Air Cleaner.....	27		
Servicing the Engine Oil.....	28		
Servicing the Spark Plug.....	31		
Cleaning the Blower Housing.....	31		
Fuel System Maintenance .....	32		
Replacing the In-Line Fuel Filter.....	32		
Electrical System Maintenance .....	33		
Electrical System Safety.....	33		
Charging the Battery .....	33		
Servicing the Fuses.....	34		

# Safety

This machine has been designed in accordance with ANSI B71.1-2012.

## General Safety

This product is capable of amputating hands and feet and of throwing objects. Always follow all safety instructions to avoid serious personal injury.

Using this product for purposes other than its intended use could prove dangerous to you and bystanders.

- Read and understand the contents of this *Operator's Manual* before you start the engine. Ensure that everyone using this product knows how to use it and understands the warnings.
- Do not put your hands or feet near moving components of the machine.
- Do not operate the machine without all guards and other safety protective devices in place and working on the machine.
- Keep clear of any discharge opening. Keep bystanders a safe distance away from the machine.
- Keep children out of the operating area. Never allow children to operate the machine.
- Stop the machine and shut off the engine before servicing, fueling, or unclogging the machine.

Improperly using or maintaining this machine can result in injury. To reduce the potential for injury, comply with these safety instructions and always pay attention to the safety-alert symbol, which means Caution, Warning, or Danger—personal safety instruction. Failure to comply with these instructions may result in personal injury or death.

You can find additional items of safety information in their respective sections throughout this manual.

# Slope Indicator

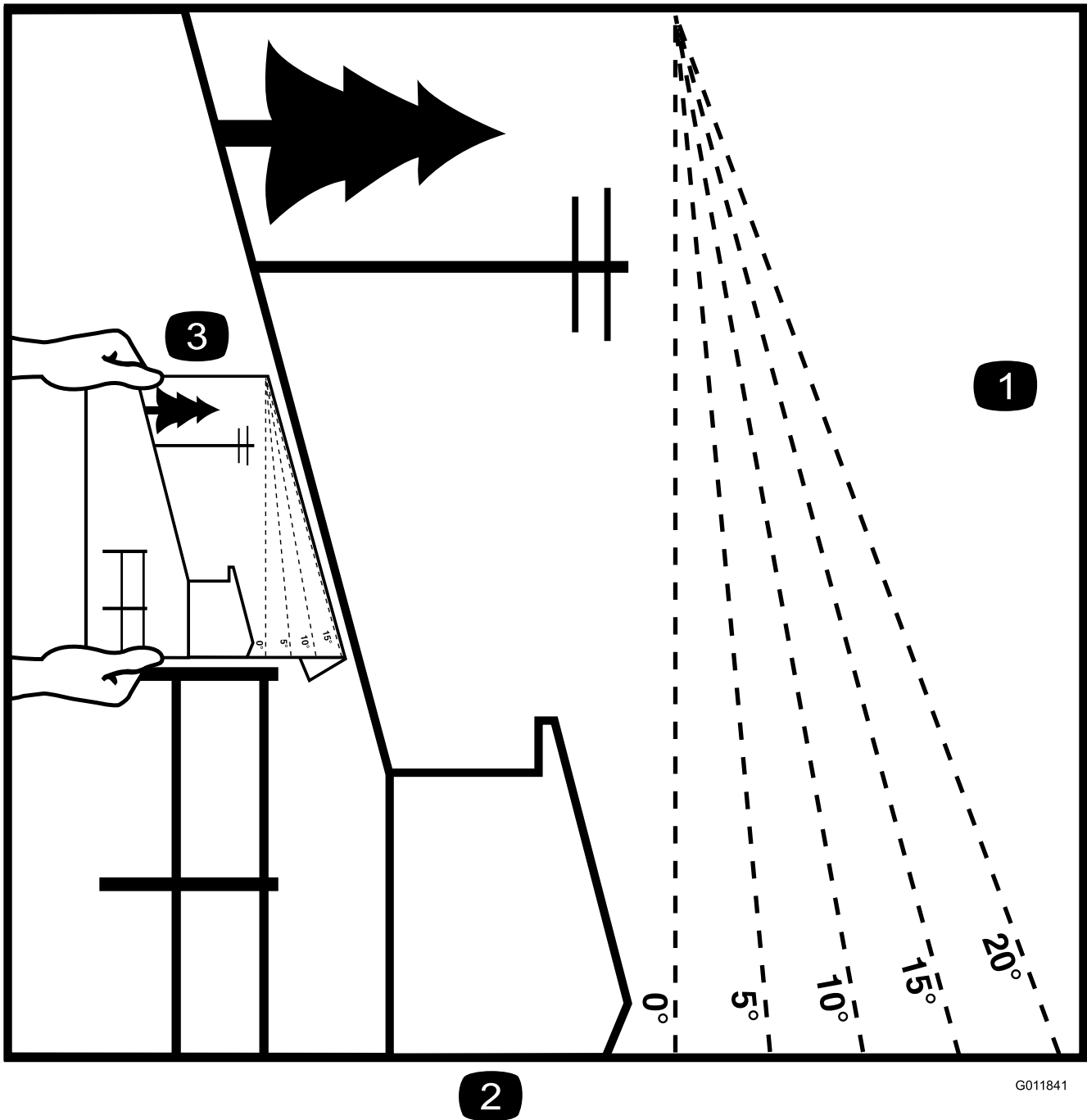

2

G011841

g011841

**Figure 3**

This page may be copied for personal use.

1. The maximum slope you can safely operate the machine on is **15 degrees**. Use the slope chart to determine the degree of slope of hills before operating. **Do not operate this machine on a slope greater than 15 degrees.** Fold along the appropriate line to match the recommended slope.
2. Align this edge with a vertical surface, a tree, building, fence pole, etc.
3. Example of how to compare slope with folded edge

# Safety and Instructional Decals



Safety decals and instructions are easily visible to the operator and are located near any area of potential danger. Replace any decal that is damaged or missing.



93-7009

decal93-7009

1. Warning—don't operate the mower with the deflector up or removed; keep the deflector in place.
2. Cutting/dismemberment hazard of hand or foot, mower blade—stay away from moving parts.

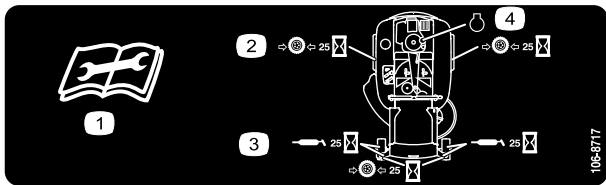

106-8717

decal106-8717

1. Read the instructions before servicing or performing maintenance.
2. Check tire pressure every 25 operating hours.
3. Grease every 25 operating hours.
4. Engine

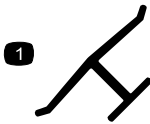

Manufacturer's Mark

decaloemmark

1. Indicates the blade is identified as a part from the original machine manufacturer.

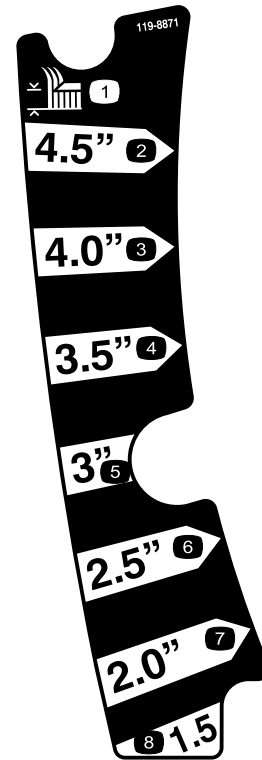

119-8871

decal119-8871

1. Height-of-cut

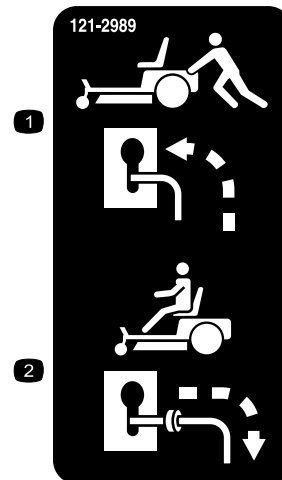

121-2989

decal121-2989b

1. Bypass lever position for pushing the machine
2. Bypass lever position for operating the machine



**Battery Symbols**

Some or all of these symbols are on your battery.

- |  |   |
|--|---|
| 1. Explosion hazard                    | 6. Keep bystanders a safe distance away from the battery.                       |
| 2. No fire, open flame, or smoking     | 7. Wear eye protection; explosive gases can cause blindness and other injuries. |
| 3. Caustic liquid/chemical burn hazard | 8. Battery acid can cause blindness or severe burns.                            |
| 4. Wear eye protection.                | 9. Flush eyes immediately with water and get medical help fast.                 |
| 5. Read the <i>Operator's Manual</i> . | 10. Contains lead; do not discard.  |

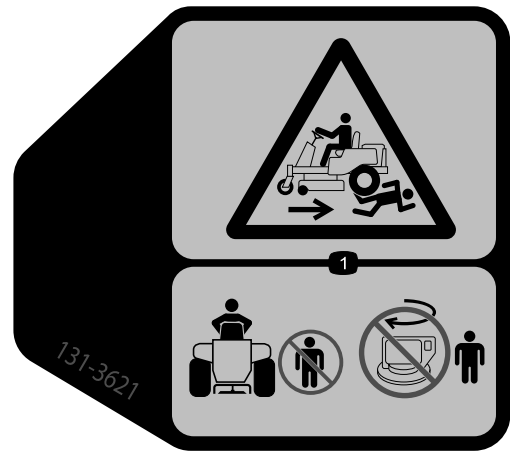

**131-3621**

decal131-3621b

1. Crushing/dismemberment hazard of bystanders—keep bystanders away from the machine; do not start the machine with bystanders nearby.

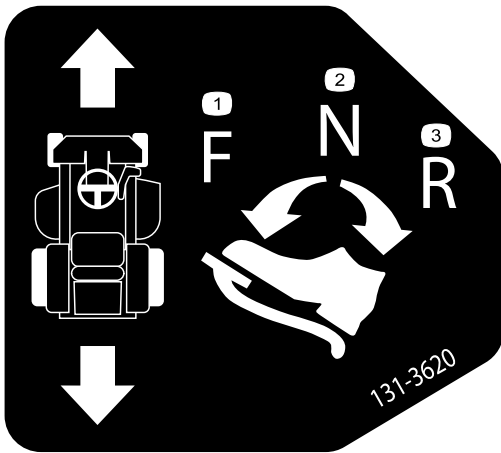

**131-3620**

decal131-3620

1. Pedal position—forward
2. Pedal position—neutral
3. Pedal position—reverse



**131-3665**

decal131-3665

1. Blade spinning
2. Reverse
3. Read the *Operator's Manual*.



**131-3955**

decal131-3955

1. On
2. Off

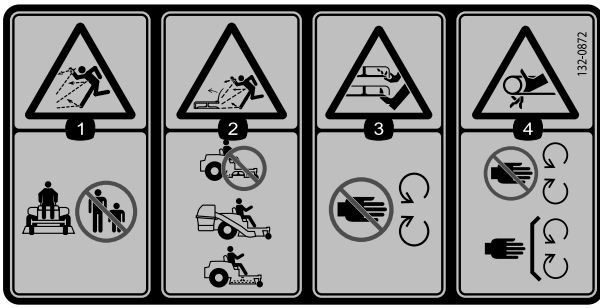

132-0872

decal132-0872

1. Thrown object hazard—keep bystanders away from the machine.
2. Thrown object hazard, raised baffle—do not operate the machine with an open deck; use a baffle or a baffle.
3. Severing hazard of hand or foot—keep away from moving parts.
4. Entanglement hazard—keep away from moving parts; keep all guards and shields in place.



132-6863

decal132-6863

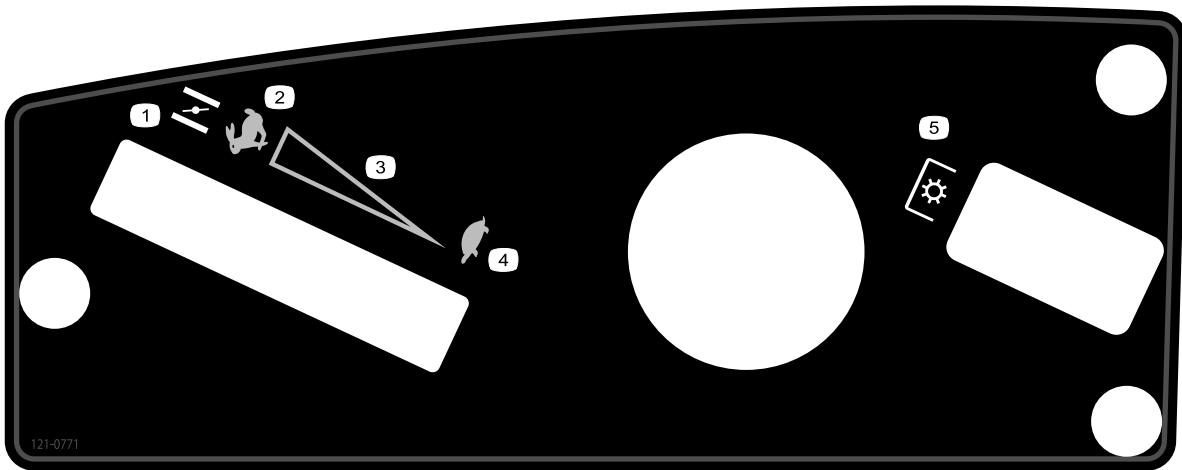

121-0771

decal121-0771

1. Choke
2. Fast
3. Continuous variable setting
4. Slow
5. Power take-off (PTO), Blade control switch

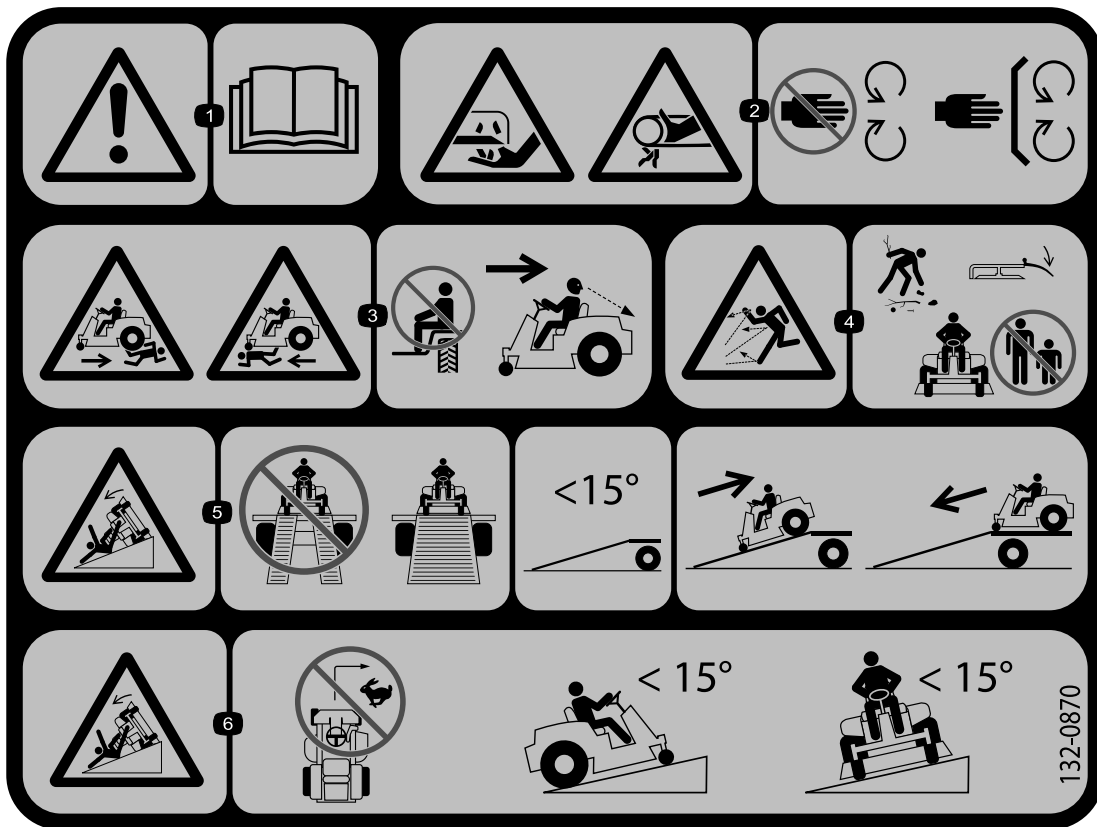

132-0870

dccal132-0870

1. Warning—read the *Operator's Manual*.
2. Cutting hazard of hand, mower blade; pinching hazard of hand, belt—keep hands and feet away from moving parts; keep all guards and shields in place.
3. Bodily harm hazard—no riders; look behind you when mowing in reverse.
4. Thrown object hazard—keep bystanders away from the machine; remove debris from the area before mowing; keep the deflector shield down.
5. Ramp tipping hazard—when loading onto a trailer, do not use dual ramps; only use a single ramp wide enough for the machine and that has an incline less than 15 degrees; back up the ramp (in reverse) and drive forward off the ramp.
6. Tipping hazard on slopes—do not make sharp, quick turns; do not use slopes greater than 15 degrees.

# Product Overview

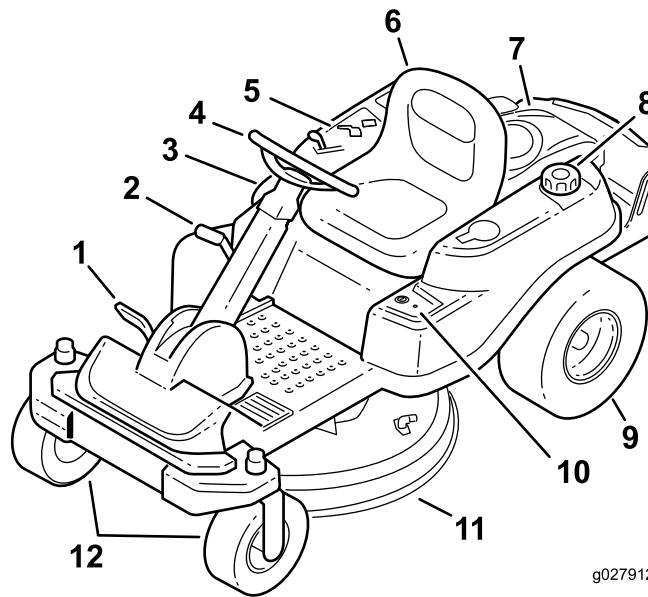

g027912

g027912

**Figure 4**

- |                           |                   |                     |                         |
|---------------------------|-------------------|---------------------|-------------------------|
| 1. Traction-control pedal | 4. Steering wheel | 7. Engine           | 10. Key Choice® control |
| 2. Height-of-cut lever    | 5. Control panel  | 8. Fuel-tank cap    | 11. Mower deck          |
| 3. SmartPark™ switch      | 6. Operator seat  | 9. Rear drive wheel | 12. Front caster wheels |

## Controls

Become familiar with all controls in [Figure 4](#), [Figure 5](#), and [Figure 6](#) before you start the engine and operate the machine.

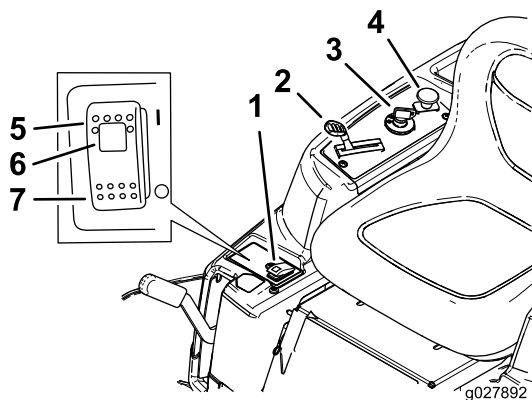

g027892

g027892

**Figure 5**  
Control Panel

- |  |                                  |
|--|----------------------------------|
| 1. SmartPark™ switch                     | 5. Parking brake—On              |
| 2. Throttle/Choke control                | 6. Parking brake indicator light |
| 3. Ignition switch                       | 7. Parking brake—Off             |
| 4. Blade-control switch (power take-off) |                                  |

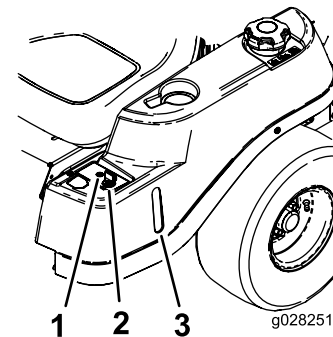

g028251

g028251

**Figure 6**

- |                                       |                         |
|---------------------------------------|-------------------------|
| 1. Operating-in-Reverse warning light | 3. Fuel-presence window |
| 2. Key Choice key (blue in color)     |                         |

## Ignition Switch

Use this switch to start the mower engine. It has 3 positions: START, RUN, and OFF.

## Throttle/Choke Control

The throttle and choke controls are combined into 1 control lever. The throttle controls the engine speed and has a continuous-variable setting from SLOW to FAST. Engage the choke by moving the lever past the FAST setting until it stops (Figure 5).

## Blade-Control Switch (Power Takeoff)

The blade-control switch (PTO) engages and disengages power to the mower blades (Figure 5).

## Fuel-Presence Window

The fuel window, located on the left side of the machine, can be used to verify the presence of fuel in the tank (Figure 6).

## Height-of-Cut Lever

Use the height-of-cut lever to lower and raise the deck from the seated position. Moving the lever up (toward you) raises the deck from the ground and moving the lever down (away from you) lowers the deck toward the ground. Adjust the height-of-cut only while the machine is not moving (Figure 19).

## Key Choice® Switch

This switch allows you to mow in reverse when it is activated. To activate it, turn the switch to the ON position and release it after the PTO is engaged. To deactivate it, disengage the power takeoff (PTO) (Figure 6).

## Operating-in-Reverse Warning Light

The Operating-in-Reverse warning light illuminates whenever you use the Key Choice key to deactivate the operating-in-reverse interlock. It is a reminder that the interlock system is deactivated. The light goes out whenever you disengage the PTO or shut off the engine. When the light is on, look behind you and use extra caution when backing up.

## Smart Park™ Switch

The parking brake is activated electronically.

Engage the parking brake by 1 of the following actions:

- Pressing the Smart Park™ switch to the ON position (Figure 5).
- The parking brake engages automatically when you leave the seat and the traction control pedal is in the NEUTRAL position.
- The parking brake automatically engages 5 to 6 seconds after the ignition switch is turned to the OFF position (if it is not already engaged).

To disengage the parking brake, press the Smart Park switch to the OFF position with the key in the RUN position.

## Attachments/Accessories

A selection of Toro approved attachments and accessories is available for use with the machine to enhance and expand its capabilities. Contact your Authorized Service Dealer or Distributor or go to [www.Toro.com](http://www.Toro.com) for a list of all approved attachments and accessories.

# Operation

**Note:** Determine the left and right sides of the machine from the normal operating position.

## Before Operation

### Before Operation Safety

#### General Safety

- Never allow children or untrained people to operate or service the machine. Local regulations may restrict the age of the operator. The owner is responsible for training all operators and mechanics.
- Become familiar with the safe operation of the equipment, operator controls, and safety signs.
- Know how to stop the machine and shut off the engine quickly.
- Check that operator-presence controls, safety switches, and shields are attached and functioning properly. Do not operate the machine unless they are functioning properly.
- Before mowing, always inspect the machine to ensure that the blades, blade bolts, and cutting assemblies are in good working condition. Replace worn or damaged blades and bolts in sets to preserve balance.
- Inspect the area where you will use the machine and remove all objects that the machine could throw.
- Evaluate the terrain to determine the appropriate equipment and any attachments or accessories required to operate the machine properly and safely.

#### Fuel Safety

- To avoid personal injury or property damage, use extreme care in handling fuel. Fuel vapors are flammable and explosive.
- Extinguish all cigarettes, cigars, pipes, and other sources of ignition.
- Use only an approved fuel container.
- Do not remove the fuel cap or add fuel to the fuel tank while the engine is running or while hot.
- Do not refuel the machine indoors.
- Do not store the machine or fuel container where there is an open flame, spark, or pilot light, such as on a water heater or on other appliances.
- Do not fill containers inside a vehicle or on a truck or trailer bed with a plastic liner. Always place containers on the ground, away from your vehicle before filling.
- Remove the equipment from the truck or trailer and refuel it while it is on the ground. If this is not possible, then refuel from a portable container rather than a fuel-dispenser nozzle.

- Do not operate the machine without the entire exhaust system in place and in proper working condition.
- Keep the fuel-dispenser nozzle in contact with the rim of the fuel tank or container opening at all times until fueling is complete. Do not use a nozzle lock-open device.
- If you spill fuel on your clothing, change your clothing immediately. Wipe up any fuel that spills.
- Never overfill the fuel tank. Replace the fuel cap and tighten it securely.
- Store fuel in an approved container and keep it out of the reach of children. Never buy more than a 30-day supply of fuel.
- Do not fill the fuel tank completely full. Add fuel to the fuel tank until the level is 6 to 13 mm (1/4 to 1/2 inch) below the bottom of the filler neck. This empty space in the tank allows fuel to expand.
  - Avoid prolonged breathing of vapors.
  - Keep your face away from the nozzle and fuel tank opening.
  - Avoid contact with skin; wash off spills with soap and water.

### Recommended Fuel

- For best results, use only clean, fresh (less than 30 days old), unleaded gasoline with an octane rating of 87 or higher ((R+M)/2 rating method).
- **Ethanol:** Gasoline with up to 10% ethanol (gasohol) or 15% MTBE (methyl tertiary butyl ether) by volume is acceptable. Ethanol and MTBE are not the same. Gasoline with 15% ethanol (E15) by volume is not approved for use. **Never use gasoline that contains more than 10% ethanol by volume**, such as E15 (contains 15% ethanol), E20 (contains 20% ethanol), or E85 (contains up to 85% ethanol). Using unapproved gasoline may cause performance problems and/or engine damage which may not be covered under warranty.
- **Do not** use gasoline containing methanol.
- **Do not** store fuel either in the fuel tank or fuel containers over the winter unless you use a fuel stabilizer.
- **Do not** add oil to gasoline.

### Using Stabilizer/Conditioner

Use a fuel stabilizer/conditioner in the machine to provide the following benefits:

- Keeps fuel fresh during storage of 90 days or less (drain the fuel tank when storing the machine for more than 90 days)
- Cleans the engine while it runs
- Eliminates gum-like varnish buildup in the fuel system, which causes hard starting

**Important:** Do not use fuel additives containing methanol or ethanol.

Add the correct amount of fuel stabilizer/conditioner to the fuel.

**Note:** A fuel stabilizer/conditioner is most effective when mixed with fresh fuel. To minimize the chance of varnish deposits in the fuel system, use fuel stabilizer at all times.

## Filling the Fuel Tank

1. Park the machine on level ground.
2. Shut off the engine and engage the parking brake.
3. Clean around the fuel-tank cap.
4. Fill the fuel tank to the bottom of the filler neck (Figure 7).

**Note:** Do not fill the fuel tank completely full. The empty space in the tank allows the fuel to expand.

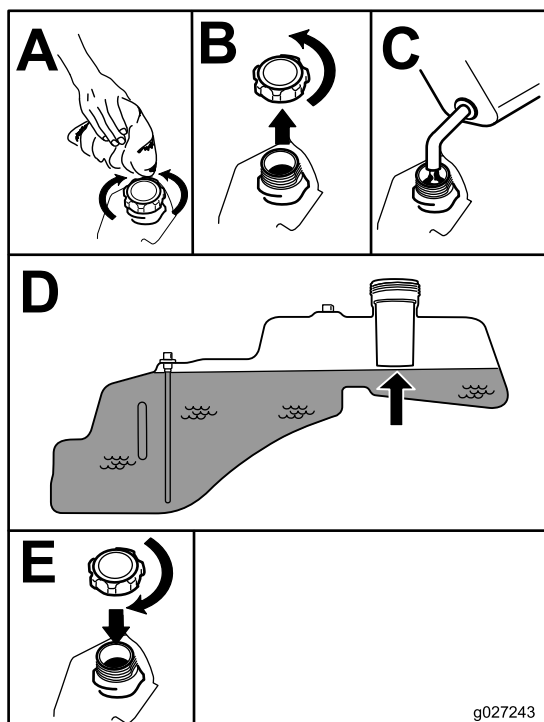

Figure 7

## Breaking in a New Machine

New engines take time to develop full power. Mower decks and drive systems have higher friction when new, placing additional load on the engine. Allow 40 to 50 hours of break-in time for new machines to develop full power and best performance.

## Think Safety First

Please read all safety instructions and symbols in the safety section. Knowing this information could help you or bystanders avoid injury.

### ⚠ DANGER

Operating the machine on wet grass or steep slopes can cause sliding and loss of control.

- Do not operate on slopes greater than 15 degrees.
- Reduce speed and use extreme caution on slopes.
- Do not operate the machine near water.

### ⚠ DANGER

Wheels dropping over edges can cause rollovers, which may result in serious injury, death, or drowning.

Do not operate the machine near drop-offs.

### ⚠ DANGER

Operating the machine while the roll bar is down may lead to serious injury or death in the event of a rollover.

Always keep the roll bar in the fully raised and locked position and use the seat belt.

## Checking the Engine-Oil Level

Before you start the engine and use the machine, check the oil level in the engine crankcase; refer to [Checking the Engine-Oil Level](#) (page 28).

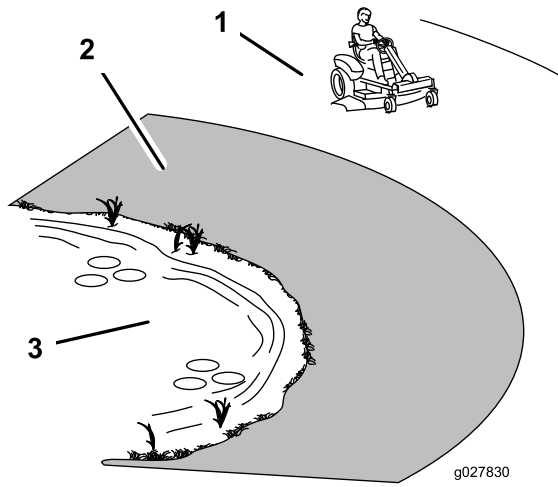

**Figure 8**

1. Safe Zone—use the machine here on slopes less than 15 degrees or flat areas.
2. Danger Zone—use a walk-behind mower and/or a hand trimmer on slopes greater than 15 degrees and near drop-offs or water.
3. Water

**⚠ CAUTION**

This machine produces sound levels in excess of 85 dBA at the operator's ear and can cause hearing loss through extended periods of exposure.

Wear hearing protection when operating this machine.

Use protective equipment for your eyes, ears, hands, feet, and head.

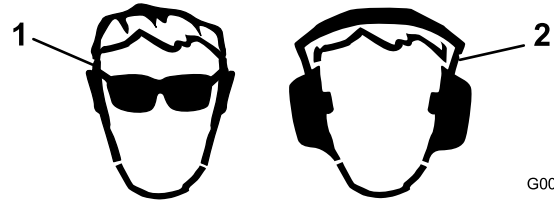

**Figure 9**

1. Wear eye protection.
2. Wear hearing protection.

# Using the Safety-Interlock System

## **⚠ WARNING**

If safety-interlock switches are disconnected or damaged, the machine could operate unexpectedly causing personal injury.

- Do not tamper with the interlock switches.
- Check the operation of the interlock switches daily, and replace any damaged switches before operating the machine.

## Understanding the Safety-Interlock System

The safety-interlock system is designed for the following:

- To prevent the engine from starting unless the traction pedal is in the NEUTRAL position.
- To automatically ensure that the parking brake is engaged and the PTO is off when starting the machine.
- To shut off the engine whenever the traction pedal is not in the NEUTRAL position and you rise from the seat.
- To automatically engage the parking brake and disengage the PTO, when you rise out of the seat with the traction pedal in the NEUTRAL position.
- To shut off the engine whenever the parking brake is not engaged and you rise from the seat.

## Testing the Safety-Interlock System

1. Sit in the seat with the engine off and ensure that the PTO switch is in the OFF position.
2. Turn the ignition key to the START position; the starter should crank. Do not start or shut off the engine prior to step 3.
3. Turn the key to the ON position and push the Smart Park switch to the OFF position. The brake should disengage and the brake light should turn off.
4. With the brake disengaged and traction pedal in the NEUTRAL position, turn the ignition switch to the START position. The brake should automatically engage, the engine should crank, and the brake light should turn on.
5. With the engine off and the key in the ON position, engage the PTO by pulling up the blade-control switch; you should hear the clutch engage.
6. Ensure that the traction pedal is in neutral and turn the ignition switch to the START position. The PTO should disengage and the engine should crank and start without the blades moving.
7. With the engine running, rise from the seat. The engine should remain running and the brake light should be on.
8. Return to the seat and disengage the parking brake by pushing the Smart Park switch to the OFF position. The engine should continue to run.
9. Rise from the seat again. The brake should automatically engage and the engine should continue to run.
10. Return to the seat and engage the blades by pulling up the blade-control switch.
11. Rise from the seat. The blades should disengage and the engine should continue to run.
12. Return to the seat and pull up the blade-control switch. The blades should engage. Disengage the blades by pushing down the blade-control switch.
13. Pull up the blade-control switch to engage the blades. Move the traction pedal to the REVERSE position. The blades should disengage. Move the traction pedal to the NEUTRAL position.
14. Pull up the blade-control switch to engage the blades. Turn the Key Choice switch to the ON position and release it. The operating-in-reverse light should illuminate.
15. Move the traction pedal to the REVERSE position. The blades should remain engaged. Push the blade-control switch in to disengage the blades. The operating-in-reverse light should turn off. Move the traction pedal to the NEUTRAL position.
16. If not engaged, push the SmartPark switch to the ON position and lightly tap the traction pedal in the either

the FORWARD or REVERSE position. The brake should disengage and the brake light should turn off.

**Note:** Tap the pedal, do not fully engage the pedal as that causes the brake system to bind and not release.

17. With the brake released, engage the traction pedal slightly and rise from the seat. The engine should shut off.
18. Return to the seat and turn the ignition key to the OFF position. After several seconds, the brake system should engage.

**Note:** With the key in the OFF position, the brake light does not illuminate.

## Positioning the Seat

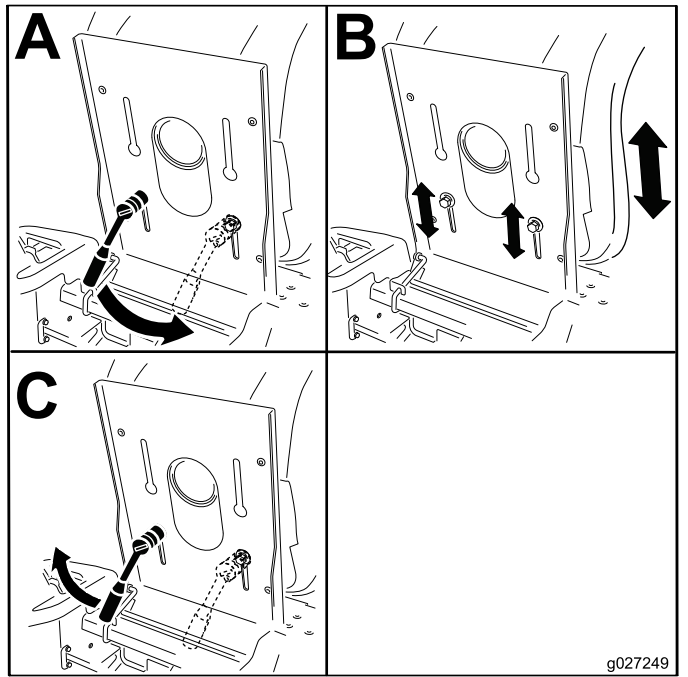

Figure 10

## Positioning the Steering Wheel

The steering wheel has 3 positions for operation and 1 full-up position. Use the full-up position for stepping on and off the machine and getting out of the seat. When operating the machine, position the steering wheel where you have the best control of the machine and are most comfortable.

1. Press your foot onto the steering-column release lever.
2. Position the steering wheel to the desired position (Figure 11).

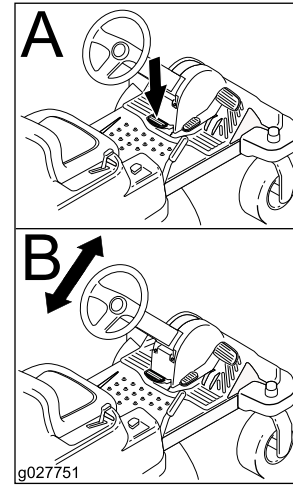

Figure 11

## During Operation

### During Operation Safety

#### General Safety

- The owner/operator can prevent and is responsible for accidents that may cause personal injury or property damage.
- Wear appropriate clothing, including eye protection; slip-resistant, substantial footwear; and hearing protection. Tie back long hair and do not wear jewelry.
- Do not operate the machine while ill, tired, or under the influence of alcohol or drugs.
- Never carry passengers on the machine and keep bystanders and pets away from the machine during operation.
- Operate the machine only in good visibility to avoid holes or hidden hazards.
- Avoid mowing on wet grass. Reduced traction could cause the machine to slide.
- Ensure that all drives are in neutral, the parking brake is engaged, and you are in the operating position before you start the engine.

- Keep your hands and feet away from the cutting units. Keep clear of the discharge opening at all times.
- Look behind and down before backing up to be sure of a clear path.
- Use care when approaching blind corners, shrubs, trees, or other objects that may obscure your vision.
- Do not mow near drop-offs, ditches, or embankments. The machine could suddenly roll over if a wheel goes over the edge or if the edge gives way.
- Stop the blades whenever you are not mowing.
- Stop the machine and inspect the blades after striking an object or if there is an abnormal vibration in the machine. Make all necessary repairs before resuming operation.
- Slow down and use caution when making turns and crossing roads and sidewalks with the machine. Always yield the right-of-way.
- Disengage the drive to the cutting unit and shut off the engine before adjusting the height of cut (unless you can adjust it from the operating position).
- Never run an engine in an area where exhaust gases are enclosed.
- Never leave a running machine unattended.
- Before leaving the operating position (including to empty the catchers or to unclog the chute), do the following:
  - Stop the machine on level ground.
  - Disengage the power take-off and lower the attachments.
  - Engage the parking brake.
  - Shut off the engine and remove the key.
  - Wait for all moving parts to stop.
- Do not operate the machine when there is the risk of lightning.
- Do not use the machine as a towing vehicle.
- Do not change the governor speed or overspeed the engine.
- Use accessories and attachments approved by Toro only.

## Slope Safety

- Slow down the machine and use extra care on hillsides. Travel up and down on hillsides. Turf conditions can affect the stability of the machine.
- Avoid turning the machine on slopes. If you must turn the machine, turn it slowly and gradually downhill, if possible.
- Do not turn the machine sharply. Use care when reversing the machine.
- Use extra care while operating the machine with attachments; they can affect the stability of the machine.

## Operating the Smart Park™ Parking Brake

The parking brake is activated electronically.

Engage the parking brake by 1 of the following actions:

- Pressing the Smart Park™ switch to the ON position (Figure 5).
- The parking brake engages automatically when the operator leaves the seat and the traction control pedal is in the NEUTRAL position.
- The parking brake automatically engages 5 to 6 seconds after the ignition switch is turned to the OFF position (if it is not already engaged).

Disengage the parking brake by 1 of the following actions:

- Tap the traction-control pedal forward or reverse.
- Pressing the brake switch to the OFF position (Figure 5).

## Operating the Mower Blade-Control Switch (PTO)

The blade-control switch (PTO) starts and stops the mower blades and any powered attachments.

### Engaging the Blade-Control Switch (PTO)

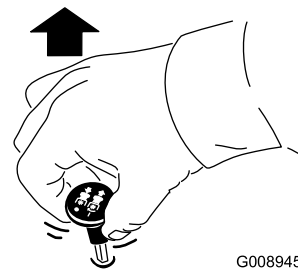

G008945

g008945

Figure 12

**Note:** Always engage the blades with the throttle in the FAST position (Figure 13).

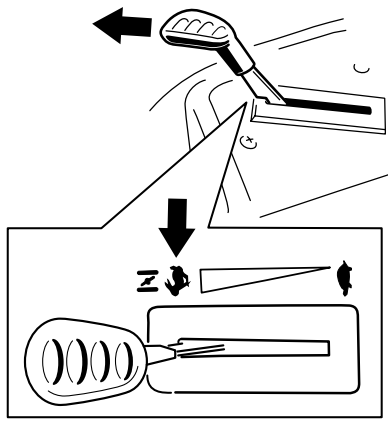

Figure 13

g186693

## Operating the Ignition Switch

1. Turn the ignition key to the START position (Figure 16).

**Note:** When the engine starts, release the key.

**Important:** Do not engage the starter for more than 5 seconds at a time. If the engine fails to start, wait 15 seconds between attempts. Failure to follow these instructions can burn out the starter motor.

**Note:** You may need multiple attempts to start the engine when you start it the first time after the fuel system has been without fuel completely.

## Disengaging the Blade-Control Switch (PTO)

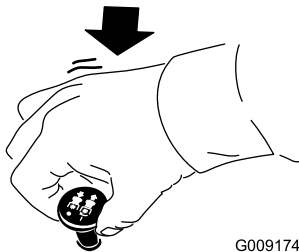

Figure 14

G009174

g009174

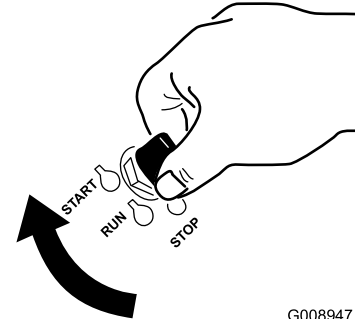

Figure 16

G008947

g008947

2. Turn the ignition key to the STOP position to shut off the engine.

## Operating the Throttle

You can move the throttle control between the FAST and SLOW positions (Figure 15).

Always use the FAST position when turning on the mower deck with the blade-control switch (PTO).

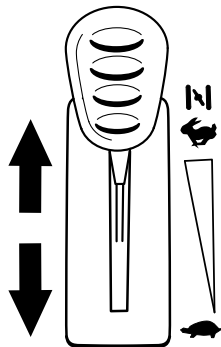

Figure 15

g187361

# Starting and Shutting Off the Engine

## Starting the Engine

**Note:** A warm or hot engine may not require choking.

**Important:** Do not engage the starter for more than 5 seconds at a time. Engaging the starter motor for more than 5 seconds can damage the starter motor. If the engine fails to start, wait 10 seconds before operating the engine starter again.

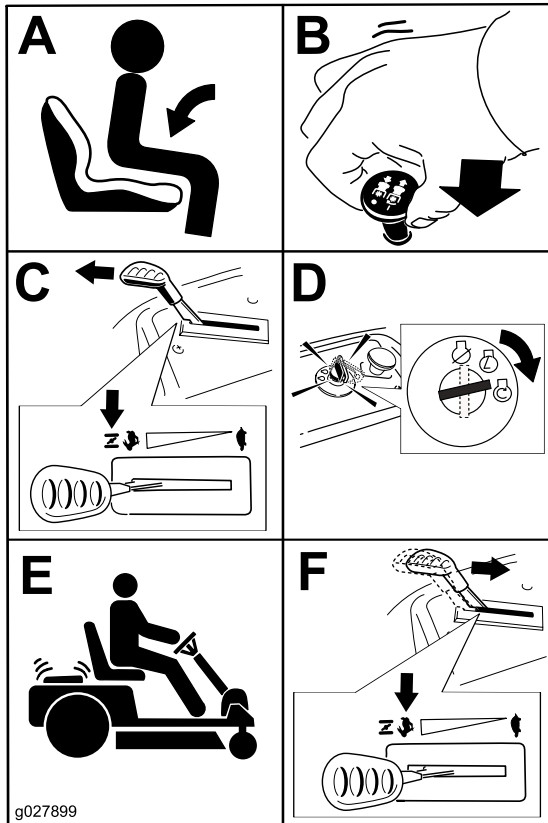

Figure 17

## Shutting Off the Engine

1. Disengage the blades by moving the blade-control switch to the OFF position (Figure 17).
2. Move the throttle lever to the FAST position.
3. Turn the ignition key to the OFF position and remove the key.

# Driving the Machine

This machine has the characteristics of both a garden tractor and a zero-turn machine. Like a garden tractor, the machine has a foot pedal that controls the forward and reverse motion along with the speed, and it has a steering wheel that controls the direction and the turning radius. Like a zero-turn machine, the rear drive wheels operate independently of each other, enabling you to make sharp turns and to turn in different directions quickly. These characteristics vastly improve the maneuverability of the machine, but they may also require you to practice driving if you are unfamiliar with this type of machine.

## ⚠ WARNING

The machine can spin very rapidly. You may lose control of the machine and cause personal injury or damage to the machine.

- Use caution when making turns.
- Slow the machine down before making sharp turns.

The throttle control regulates the engine speed as measured in rpm (revolutions per minute). Placing the throttle control in the FAST position can be best for performance. For most applications, operating in the FULL-THROTTLE position is desirable.

## Driving Forward or Backward

1. Move the throttle to the FAST position.
2. Release the parking brake.
3. Place your foot onto the traction-control pedal and slowly press the top of the pedal to go forward, or press on the bottom of the pedal to move backward (Figure 18).

**Note:** The farther you move the pedal in either direction, the faster the machine moves in that direction.

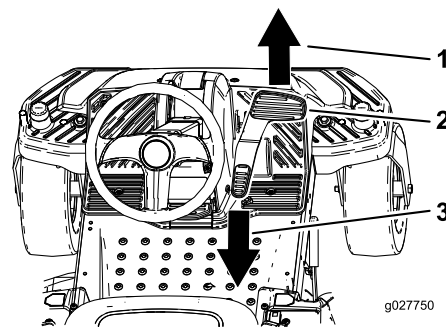

Figure 18

1. Forward
2. Traction-control pedal
3. Backward

4. To slow down, release the pressure on the traction-control pedal.

# Stopping the Machine

To shut off the machine, release the traction-control pedal, disengage the blade-control switch, ensure that the throttle is in the FAST position, engage the parking brake, and turn the ignition key to off.

**Note:** Remember to remove the key from the ignition switch.

## ⚠ WARNING

Children or bystanders may be injured if they move or attempt to operate the mower while it is unattended.

Always remove both the ignition and Key Choice keys and engage the parking brake when leaving the machine unattended, even if just for a few minutes.

# Mowing in Reverse

The machine has an interlock feature that prevents the mower deck from mowing while the machine is traveling in reverse. If you shift into reverse with the PTO engaged, the PTO stops. If you need to mow while in reverse gear, you can temporarily deactivate this interlock.

**Note:** Do not mow while backing up unless it is necessary.

## ⚠ DANGER

A child or bystander could be backed over by a riding mower with blades engaged and cause serious personal injury or death.

- Do not mow in reverse unless absolutely necessary.
- Always look backward and down before backing up.
- Use the Key Choice switch only if you are certain no children or other bystanders will appear in the mowing area.
- Always remove both the ignition and Key Choice keys and put them in a safe place out of the reach of children or unauthorized users when leaving the machine unattended.

If you are certain that you can safely mow or operate an attachment in reverse, complete the following procedure:

1. Insert the Key Choice key into the Key Choice switch (Figure 6).
2. Engage the PTO.
3. Turn the Key Choice key clockwise until it stops and release it.

**Note:** A red light illuminating on the console indicates that the interlock has been deactivated.

4. Perform the mowing.
5. When finished mowing, remove the Key Choice key (Figure 6).

**Note:** Once you deactivate the interlock, it stays in this mode—with your mower blade or PTO powered attachment operating whenever you back up—and the console light stays on until you either disengage the PTO or shut off the engine.

# Adjusting the Height of Cut

**Note:** The transport position is the highest height-of-cut position or cutting height at 115 mm (4-1/2 inches) as shown in Figure 19.

Height of cut is controlled by the lever located to the right of the operating position (Figure 19).

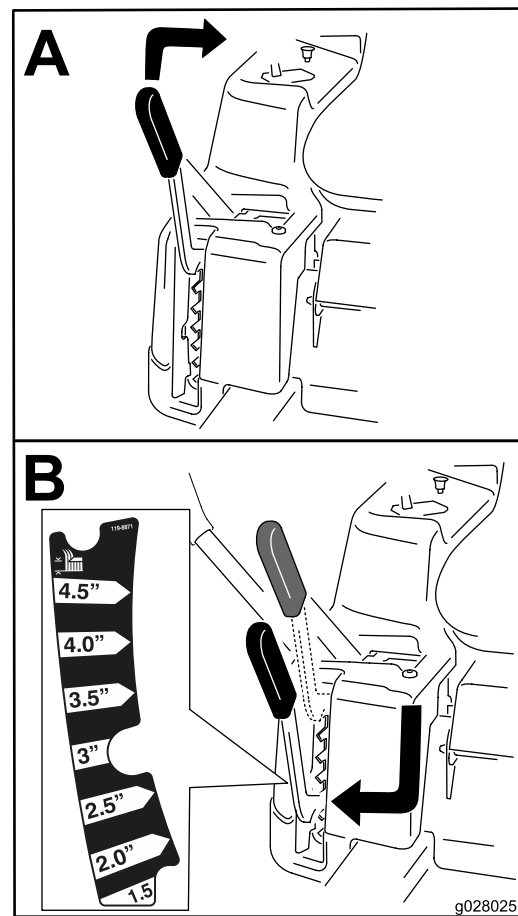

Figure 19

g028025

## Using the Grass Deflector

The mower has a hinged grass deflector that disperses clippings to the side and down toward the turf.

### **⚠ DANGER**

**Without the grass deflector, discharge cover, or complete grass catcher assembly mounted in place, you and others are exposed to blade contact and thrown debris. Contact with rotating mower blade(s) and thrown debris causes injury or death.**

- **Never remove the grass deflector from the mower, because the grass deflector routes material down toward the turf. If the grass deflector is ever damaged, replace it immediately.**
- **Never put your hands or feet under the mower.**
- **Never try to clear discharge area or mower blades unless you move the blade-control switch to the OFF position and rotate the ignition key to OFF position. Also remove the key and pull the wire off the spark plug(s).**

## Operating Tips

### Using the Fast Throttle Setting

For best mowing and maximum air circulation, operate the engine at the FAST position. Air is required to thoroughly cut grass clippings, so do not set the height-of-cut so low as to totally surround the mower in uncut grass. Always try to have 1 side of the mower free from uncut grass, which allows air to be drawn into the mower.

### Cutting a Lawn for the First Time

Cut grass slightly longer than normal to ensure that the cutting height of the mower does not scalp any uneven ground. However, the cutting height used in the past is generally the best one to use. When cutting grass longer than 15 cm (6 inches) tall, you may want to cut the lawn twice to ensure an acceptable quality of cut.

### Cutting a Third of the Grass Blade

It is best to cut only about a third of the grass blade. Cutting more than that is not recommended unless grass is sparse, or it is late fall when grass grows more slowly.

### Alternating the Mowing Direction

Alternate the mowing direction to keep the grass standing straight. This also helps disperse clippings which enhances decomposition and fertilization.

### Mowing at Correct Intervals

Grass grows at different rates at different times of the year. To maintain the same cutting height, mow more often in early spring. As the grass growth rate slows in mid summer, mow less frequently. If you cannot mow for an extended period, first mow at a high cutting height, then mow again 2 days later at a lower height setting.

### Using a Slower Cutting Speed

To improve cut quality, use a slower ground speed in certain conditions.

### Avoiding Cutting Too Low

When mowing uneven turf, raise the cutting height to avoid scalping the turf.

### Stopping the Machine

If you must stop the forward motion of the machine while mowing, a clump of grass clippings may drop onto your lawn. To avoid this, move onto a previously cut area with the blades engaged or you can disengage the mower deck while moving forward.

## Keeping the Underside of the Mower Clean

Clean clippings and dirt from the underside of the mower after each use. If grass and dirt build up inside the mower, cutting quality will eventually become unsatisfactory.

## Maintaining the Blade(s)

Maintain a sharp blade throughout the cutting season because a sharp blade cuts cleanly without tearing or shredding the grass blades. Tearing and shredding turns grass brown at the edges, which slows growth and increases the chance of disease. Check the mower blades after each use for sharpness, and for any wear or damage. File down any nicks and sharpen the blades as necessary. If a blade is damaged or worn, replace it immediately with a genuine Toro replacement blade.

# After Operation

## After Operation Safety

### General Safety

- Clean grass and debris from the cutting units, mufflers, and engine compartment to help prevent fires. Clean up oil or fuel spills.
- Shut off the fuel before storing or transporting the machine.
- Disengage the drive to the attachment whenever you are transporting or not using the machine.
- Use full-width ramps for loading the machine into a trailer or truck.
- Tie the machine down securely using straps, chains, cable, or ropes. Both front and rear straps should be directed down and outward from the machine.
- Allow the engine to cool before storing the machine in any enclosure.
- Shut off the fuel before storing or transporting the machine.
- Never store the machine or fuel container where there is an open flame, spark, or pilot light, such as on a water heater or on other appliances.

## Pushing the Machine by Hand

**Important:** Always push the machine by hand. Do not tow the machine, because damage may occur.

This machine has an electric-brake mechanism, and to push the machine, the ignition key must be in the RUN position. The battery needs to be charged and functioning for the electric brake to be disengaged.

## Pushing the Machine

1. Park the machine on a level surface, and disengage the blade-control switch.
2. Engage the parking brake, shut off the engine, and wait for all moving parts to stop before leaving the operating position.
3. Locate the bypass levers on the frame on both sides of the engine.
4. Move the bypass levers forward through the key hole and down to lock them in place (Figure 20).

**Note:** Do this for each lever.

5. Turn the ignition key on and disengage the parking brake.

**Note:** Do not start the machine.

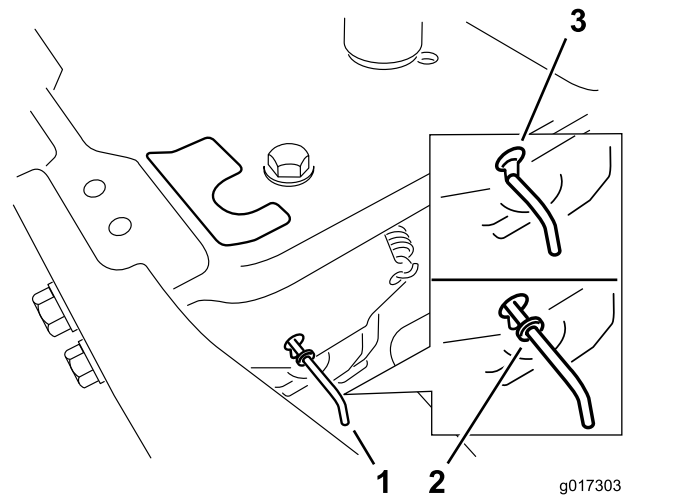

Figure 20

1. Bypass-lever locations
2. Lever position for operating the machine
3. Lever position for pushing the machine

6. When finished, ensure that the key has been returned to the STOP position to avoid draining the battery charge.

**Note:** If the machine fails to move, the electric brake may still be engaged. You can release the electric brake manually if necessary; refer to [Releasing the Electric Brake \(page 35\)](#).

## Operating the Machine

Move the bypass levers rearward through the keyhole and down to lock them in place as shown in [Figure 20](#).

**Note:** Do this for each lever.

## Transporting the Machine

Use a heavy-duty trailer or truck to transport the machine. Ensure that the trailer or truck has all necessary brakes, lighting, and marking as required by law. Please carefully read all the safety instructions. Knowing this information could help you, your family, pets, or bystanders avoid injury.

### **⚠ WARNING**

**Driving on the street or roadway without turn signals, lights, reflective markings, or a slow-moving-vehicle emblem is dangerous and can lead to accidents, causing personal injury.**

**Do not drive the machine on a public street or roadway.**

1. If you are using a trailer, connect it to the towing vehicle and connect the safety chains.
2. If applicable, connect the trailer brakes.
3. Load the machine onto the trailer or truck.
4. Shut off the engine, remove the key, engage the parking brake, and close the fuel valve.
5. Tie down the machine near the front caster wheels and the rear bumper ([Figure 21](#)).

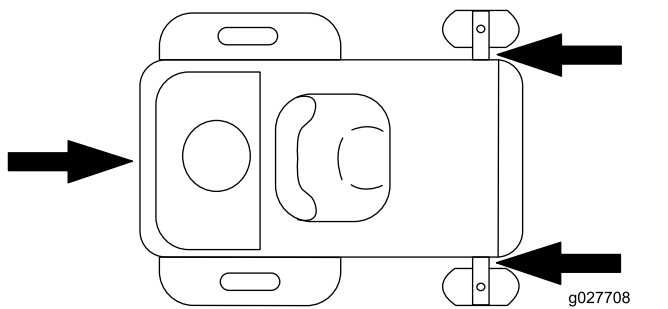

**Figure 21**

## Loading the Machine

Use extreme caution when loading or unloading machines onto a trailer or a truck. Use a full-width ramp that is wider than the machine for this procedure. Back up the ramp and drive forward down the ramp ([Figure 22](#)).

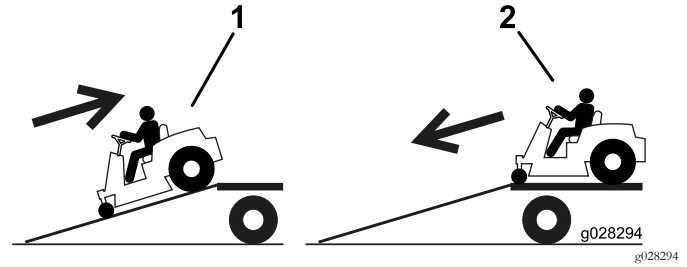

**Figure 22**

1. Back the machine up the ramp.
2. Drive the machine forward down the ramp.

**Important:** Do not use narrow individual ramps for each side of the machine.

### **⚠ WARNING**

**Loading a machine onto a trailer or truck increases the possibility of tip-over and could cause serious injury or death ([Figure 23](#)).**

- Use extreme caution when operating a machine on a ramp.
- Use only a full-width ramp; do not use individual ramps for each side of the machine.
- Do not exceed a 15-degree angle between the ramp and the ground or between the ramp and the trailer or truck.
- Ensure that the length of ramp is at least 4 times as long as the height of the trailer or truck bed to the ground. This ensures that the ramp angle does not exceed 15 degrees on flat ground.
- Back up ramps and drive forward down ramps.
- Avoid sudden acceleration or deceleration while driving the machine on a ramp as this could cause a loss of control or a tip-over situation.

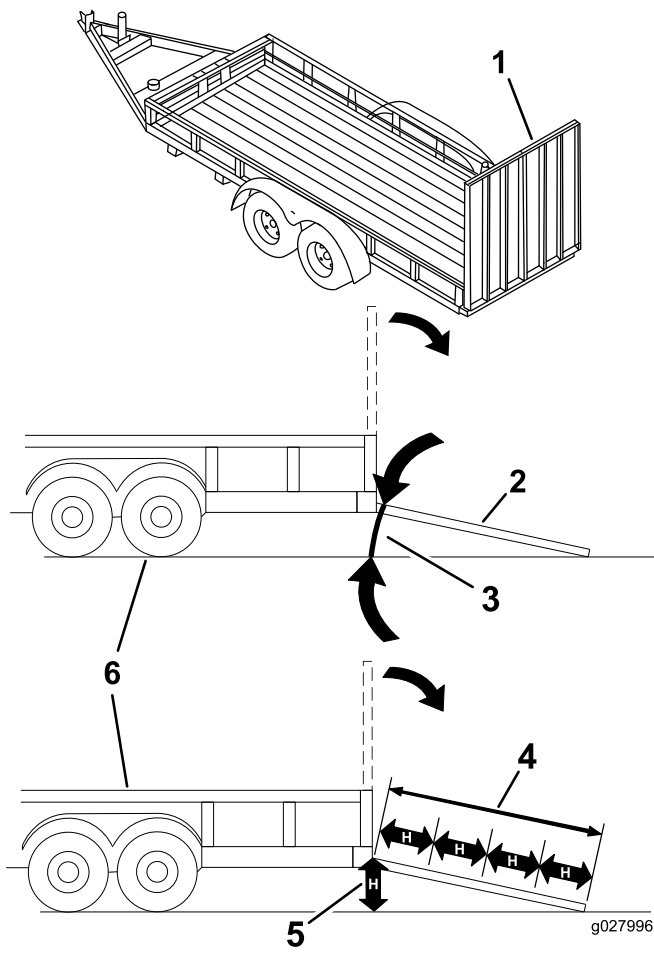

**Figure 23**

- |   |   |
|---|---|
| 1. Full-width ramp in stowed position               | 4. Ramp is at least 4 times as long as the height of the trailer or truck bed to the ground |
| 2. Side view of full-width ramp in loading position | 5. H=height of the trailer or truck bed to the ground                                       |
| 3. Not greater than 15 degrees                      | 6. Trailer  |

# Maintenance

**Note:** Determine the left and right sides of the machine from the normal operating position.

## Recommended Maintenance Schedule(s)

Maintenance Service Interval	Maintenance Procedure
After the first 5 hours	<ul style="list-style-type: none"><li>• Change the engine oil and filter.</li></ul>
Before each use or daily	<ul style="list-style-type: none"><li>• Clean and check the air cleaner foam element.</li><li>• Check the engine-oil level.</li><li>• Inspect the blades.</li><li>• Inspect the grass deflector for damage.</li></ul>
After each use	<ul style="list-style-type: none"><li>• Check and clean the front of the machine.</li><li>• Clean the mower-deck housing.</li></ul>
Every 25 hours	<ul style="list-style-type: none"><li>• Grease all the lubrication points.</li><li>• Check tire pressure.</li><li>• Check the belts for wear or cracks.</li></ul>
Every 50 hours	<ul style="list-style-type: none"><li>• Replace the air cleaner paper element.</li><li>• Check the spark plug.</li></ul>
Every 100 hours	<ul style="list-style-type: none"><li>• Change the engine oil (change it more often under a heavy load or in high temperatures).</li><li>• Change the engine-oil filter.</li><li>• Replace the spark plug.</li><li>• Clean the blower housing (more often under extremely dusty, dirty conditions).</li><li>• Replace the in-line fuel filter.</li></ul>
Before storage	<ul style="list-style-type: none"><li>• Charge the battery and disconnect battery cables.</li><li>• Perform all maintenance procedures listed above before storage.</li><li>• Paint any chipped surfaces.</li></ul>

### **▲ CAUTION**

If you leave the key in the ignition switch, someone could accidentally start the engine and seriously injure you or other bystanders.

Remove the key from the ignition and disconnect the wire from the spark plug before you do any maintenance. Set the wire aside so that it does not accidentally contact the spark plug.

## **Pre-Maintenance Procedures**

### **Maintenance and Storage**

- Before repairing the machine do the following:
  - Disengage the drives.
  - Engage the parking brake.
  - Shut off the engine and remove the key.
  - Disconnect the spark-plug wire.
- Park the machine on a level surface.
- Clean grass and debris from the cutting unit, drives, mufflers, and engine to help prevent fires.
- Clean up oil or fuel spills.
- Let the engine cool before storing the machine.
- Do not store the machine or fuel near flames or drain the fuel indoors.
- Do not allow untrained personnel to service the machine.
- Use jack stands to support the machine and/or components when required.
- Carefully release pressure from components with stored energy.
- Disconnect the battery or remove the spark-plug wire before making any repairs. Disconnect the negative terminal first and the positive terminal last. Connect the positive terminal first and negative last.
- Use care when checking the blades. Wrap the blade(s) or wear thickly padded gloves, and use caution when

servicing them. Only replace blades; do not straighten or weld them.

- Keep your hands and feet away from moving parts. If possible, do not make adjustments with the engine running.
- Keep all parts in good working condition and all hardware tightened, especially the blade-attachment bolts. Replace all worn or damaged decals.
- Never interfere with the intended function of a safety device or reduce the protection provided by a safety device. Check their proper operation regularly.
- To ensure optimum performance and continued safety certification of the machine, use only genuine Toro replacement parts and accessories. Replacement parts and accessories made by other manufacturers could be dangerous, and such use could void the product warranty.
- Check the parking brake operation frequently. Adjust and service as required.

## Raising the Seat

Ensure that the parking brake is engaged and lift the seat forward.

You can access following components by raising the seat:

- Serial plate
- Service decal
- Seat-adjustment bolts
- Fuel filter
- Battery and battery cables

## Raising the Front of the Machine

If you need to raise the front of the machine, use the very front edge as shown in [Figure 24](#).

**Important:** To prevent damage to the steering mechanism, ensure that the very front edge of the machine is used for jacking points.

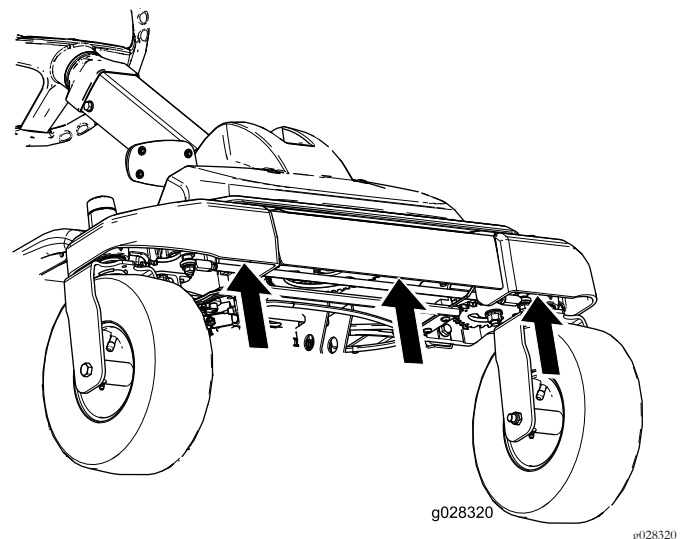

Figure 24

# Lubrication

## Greasing the Bearings

**Service Interval:** Every 25 hours—Grease all the lubrication points.

**Grease Type:** No. 2 lithium grease

1. Park the machine on a level surface, and disengage the blade-control switch.
2. Ensure that the parking brake is engaged, shut off the engine, remove the key, and wait for all moving parts to stop before leaving the operating position.
3. Clean the grease fittings (Figure 25 and Figure 26) with a rag.

**Note:** Make sure to scrape any paint off the front of the fitting(s).

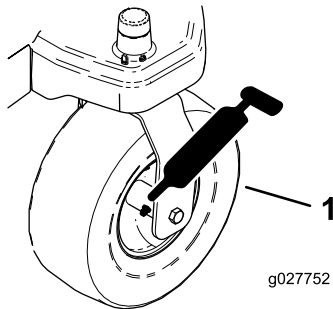

**Figure 25**

1. Front caster tire

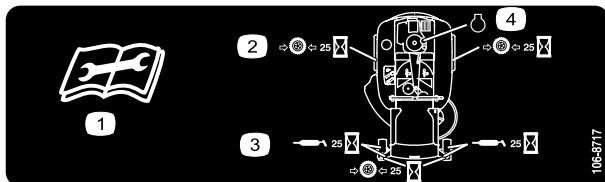

**Figure 26**

Located on the seat-pan underside

- |   |                                    |
|---|------------------------------------|
| 1. Read the instructions before servicing or performing maintenance | 3. Grease every 25 operating hours |
| 2. Check the tire pressure every 25 operating hours                 | 4. Engine                          |

4. Connect a grease gun to each fitting (Figure 25 and Figure 26).
5. Pump grease into the fittings until grease begins to ooze out of the bearings.

# Engine Maintenance

## Engine Safety

Shut off the engine before checking the oil or adding oil to the crankcase.

## Servicing the Air Cleaner

**Service Interval:** Before each use or daily—Clean and check the air cleaner foam element.

Every 50 hours—Replace the air cleaner paper element.

**Note:** Service the air cleaner more frequently (every few hours) if operating conditions are extremely dusty or sandy.

## Removing the Foam and Paper Elements

1. Park the machine on a level surface, disengage the blade-control switch (PTO), engage the parking brake, shut off the engine, remove the key, and wait for all moving parts to stop before leaving the operating position..
2. Clean around the air cleaner to prevent dirt from getting into the engine and causing damage.
3. Remove the air-cleaner cover by unscrewing the 2 knobs (Figure 27).

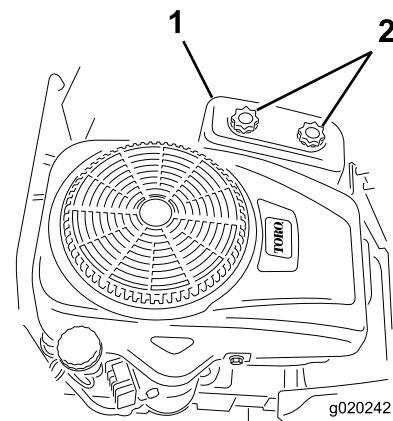

**Figure 27**

1. Air-cleaner cover
2. Knobs

4. Carefully remove the foam and paper filter elements from the air-cleaner housing (Figure 28).

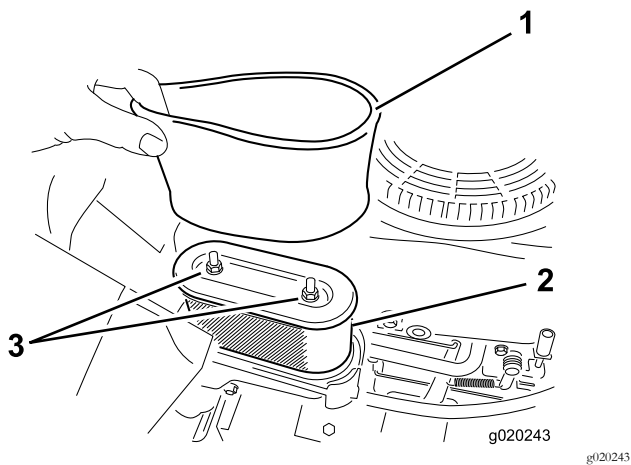

**Figure 28**

1. Foam element
2. Paper element

5. Separate the foam and paper elements.

## Cleaning the Foam and Paper Elements

### Foam Element:

1. Wash the foam element in liquid soap and warm water.
2. When the element is clean, rinse it thoroughly.
3. Dry the element by squeezing it in a clean cloth.

**Note:** Do not oil the element.

**Important:** Replace the foam element if it is torn or worn.

4. Install the foam element onto a clean paper element.

### Paper Element:

1. Tap the paper element on a solid, flat surface, and blow it out from the inside with compressed air to remove dust and dirt.
2. Inspect the element for tears, an oily film, and damage to the rubber seal.

**Important:** Do not clean the paper element with liquids, such as solvents, gasoline, or kerosene. Replace the paper element if it is damaged or cannot be cleaned thoroughly.

3. Clean the inside of the air-cleaner cover of all dirt, dust, and debris.

## Installing the Foam and Paper Elements

**Important:** To prevent engine damage, always operate the engine with the complete foam and paper air cleaner assembly installed.

1. Install the foam filter onto the paper filter (Figure 28).
2. Install the foam and paper filter onto the air-cleaner housing.
3. Install the air-cleaner cover, and tighten the 2 knobs (Figure 27).

## Servicing the Engine Oil

**Oil Type:** Detergent oil (API service SF, SG, SH, SJ, or higher)

**Crankcase Capacity:** with filter—1.4 L (1.5 US qt)

**Viscosity:** See the table below.

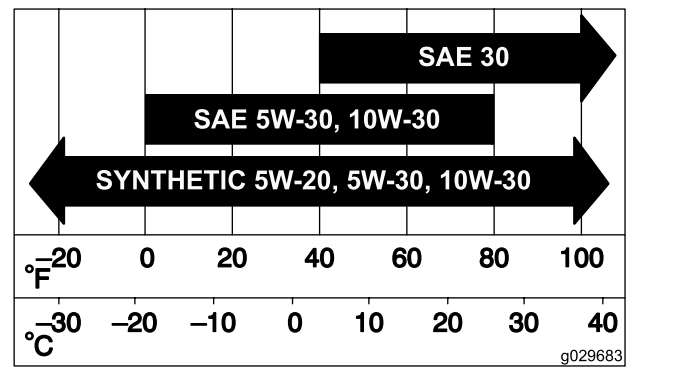

**Figure 29**

## Checking the Engine-Oil Level

**Service Interval:** Before each use or daily

**Note:** Check the oil when the engine is cold.

### ⚠ WARNING

Contact with hot surfaces may cause personal injury.

Keep hands, feet, face, clothing, and other body parts away from the muffler and other hot surfaces.

**Important:** Do not overfill the crankcase with oil, because damage to the engine may result. Do not run engine with oil below the Low mark, because the engine may be damaged.

1. Park the machine on a level surface, disengage the blade-control switch, shut off the engine, engage the parking brake, and remove the key.
2. Make sure that the engine is stopped, level, and is cool, so the oil has had time to drain into the sump.

- To keep dirt, grass clippings, etc., out of the engine, clean the area around the oil-fill cap and dipstick before removing it (Figure 30).

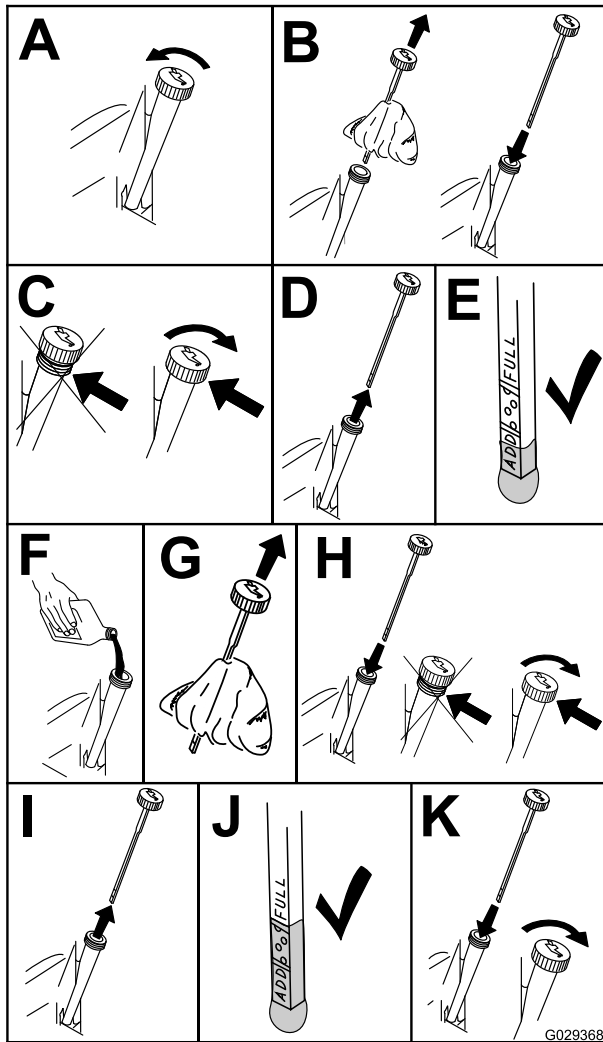

Figure 30

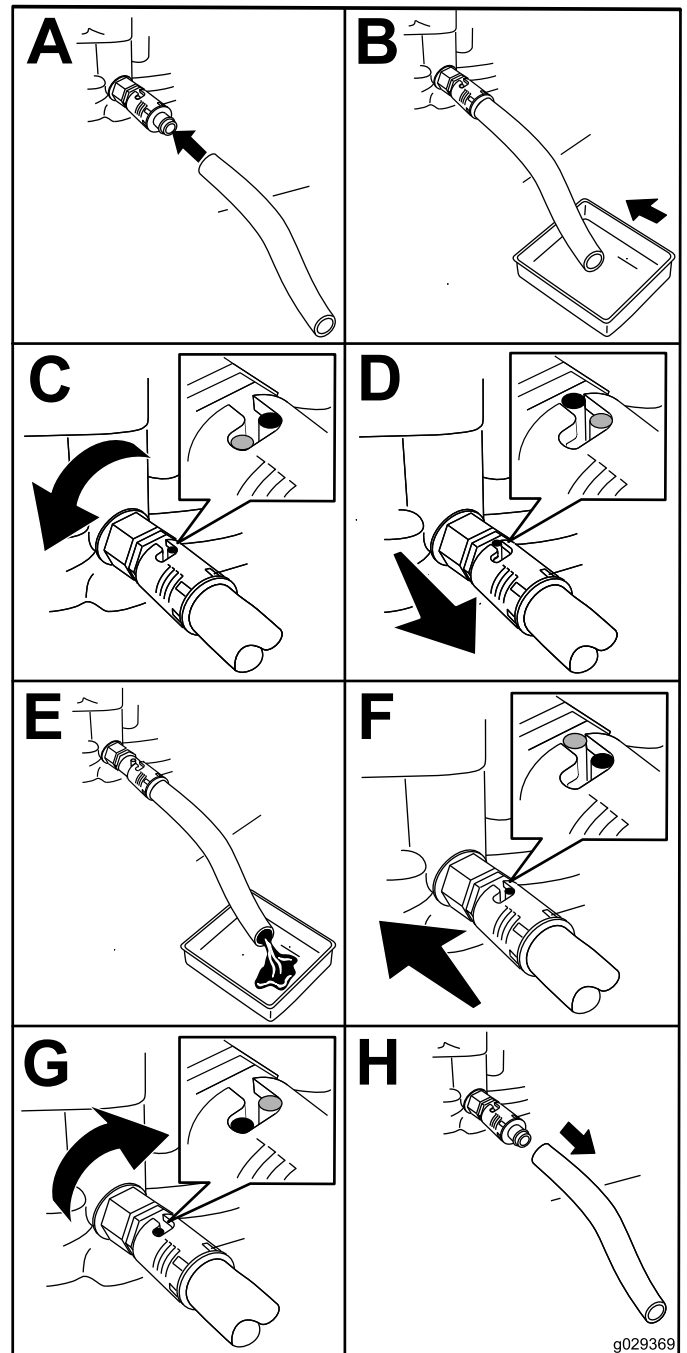

Figure 31

## Changing the Engine Oil and Filter

**Service Interval:** After the first 5 hours

Every 100 hours (change it more often under a heavy load or in high temperatures).

Every 100 hours

**Note:** Change the engine-oil filter more frequently when the operating conditions are extremely dusty or sandy.

- Park the machine, so that the right side is slightly lower than the left side, to ensure that the oil drains completely.
- Disengage the PTO and engage the parking brake.
- Shut off the engine, wait for all moving parts to stop, and remove the key before leaving the operating position.
- Drain the oil from the engine.

- Change the engine-oil filter.

**Note:** Ensure the oil-filter gasket touches the engine, and then turn the filter an extra 3/4 turn.

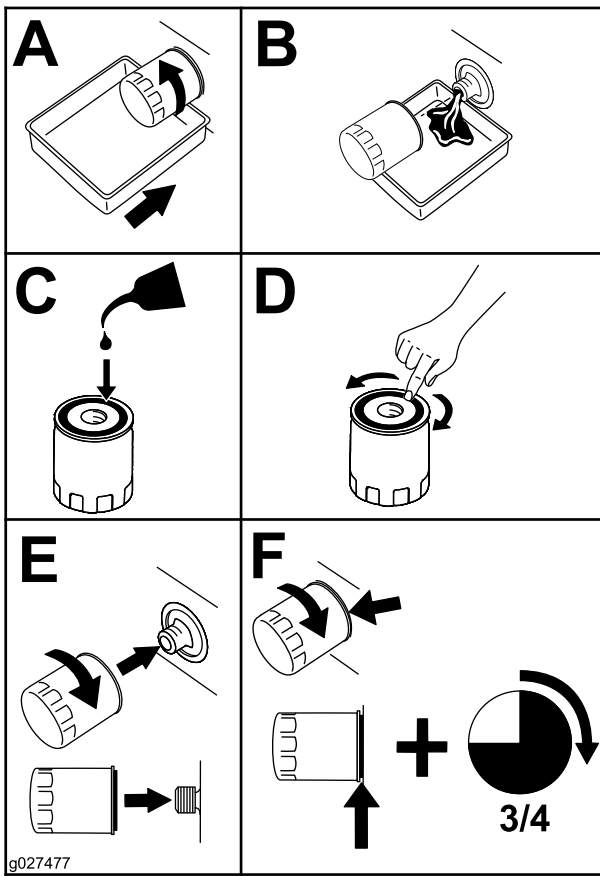

Figure 32

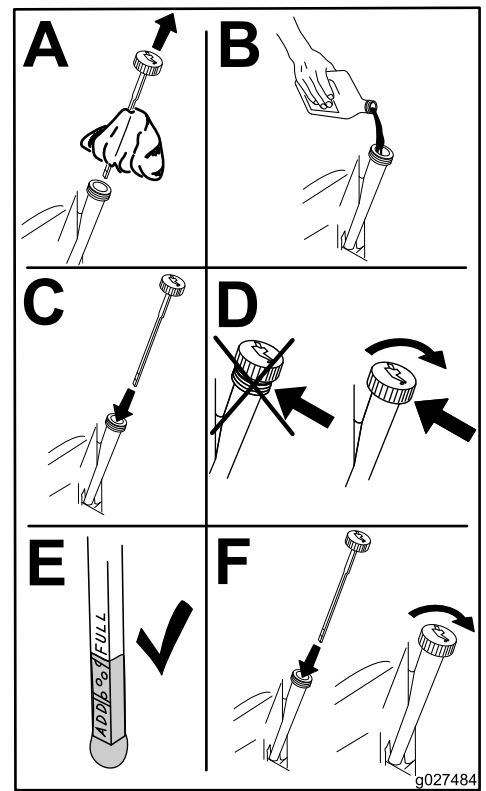

Figure 33

6. Slowly pour approximately 80% of the specified oil into the filler tube and slowly add the additional oil to bring it to the **Full** mark (Figure 33).

# Servicing the Spark Plug

**Service Interval:** Every 50 hours—Check the spark plug.

Every 100 hours—Replace the spark plug.

Ensure that the air gap between the center and side electrodes is correct before installing the spark plug. Use a spark plug wrench for removing and installing the spark plug and a gapping tool or feeler gauge to check and adjust the air gap. Install a new spark plug if necessary.

**Type:** Champion® RC12YC, Autolite® 3924, or NGK® BCPR6ES

**Air Gap:** 0.76 mm (0.03 inch)

## Removing the Spark Plug

1. Disengage the blade-control switch, engage the parking brake, shut off the engine, and remove the key.
2. Before removing the spark plug(s), clean the area around the base of the plug to keep dirt and debris out of the engine.
3. Remove the spark plug (Figure 34).

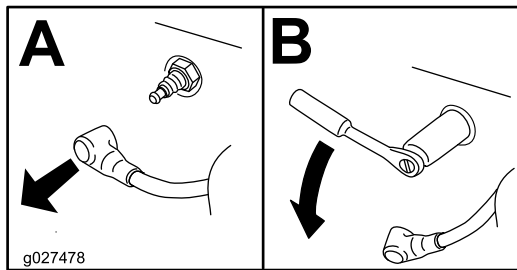

Figure 34

## Checking the Spark Plug

**Important:** Do not clean the spark plug(s). Always replace the spark plug(s) when it has: a black coating, worn electrodes, an oily film, or cracks.

**Note:** If you see light brown or gray on the insulator, the engine is operating properly. A black coating on the insulator usually means the air cleaner is dirty.

Set the gap to 0.76 mm (0.030 inch).

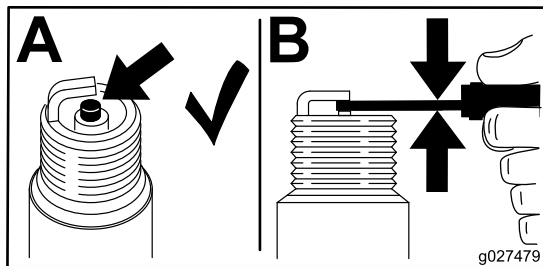

Figure 35

## Installing the Spark Plug

Tighten the spark plug to 20 N·m (15 ft-lb).

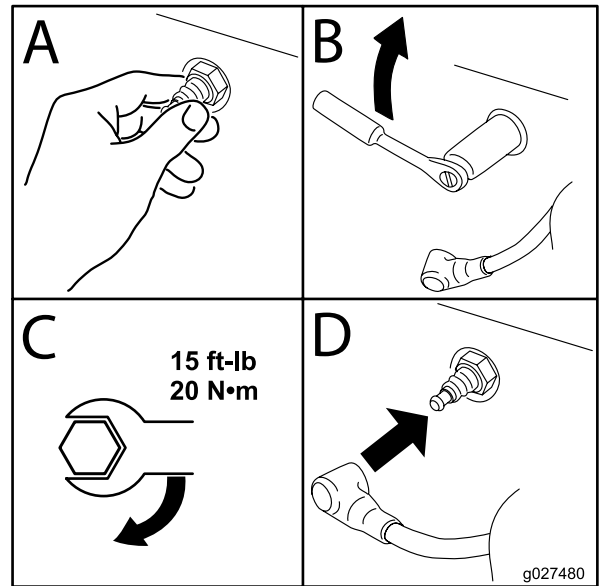

Figure 36

## Cleaning the Blower Housing

**Service Interval:** Every 100 hours/Yearly (whichever comes first)

To ensure proper cooling, make sure that the grass screen, cooling fins, and other external surfaces of the engine are kept clean at all times.

Clean the cooling fins and external surfaces as necessary. Make sure that the cooling shrouds are installed. Torque the blower housing screws to 7.5 N·m (5.5 ft-lb).

**Important:** Operating the engine with a blocked grass screen, dirty or plugged cooling fins, and/or cooling shrouds removed, causes engine damage due to overheating.

# Fuel System Maintenance

## **▲ DANGER**

In certain conditions, fuel is extremely flammable and highly explosive. A fire or explosion from fuel can burn you, others, and can damage property.

- Perform any fuel-related maintenance when the engine is cold. Do this outdoors in an open area. Wipe up any fuel that spills.
- Never smoke when draining fuel, and stay away from an open flame or where a spark may ignite the fuel fumes.

## Replacing the In-Line Fuel Filter

**Service Interval:** Every 100 hours—Replace the in-line fuel filter.

Never install a dirty filter if it is removed from the fuel line.

1. Park the machine on a level surface and disengage the blade-control switch.
2. Engage the parking brake, shut off the engine, remove the key, and wait for all moving parts to stop before leaving the operating position.

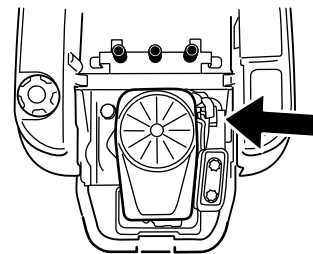

g027506

g027506

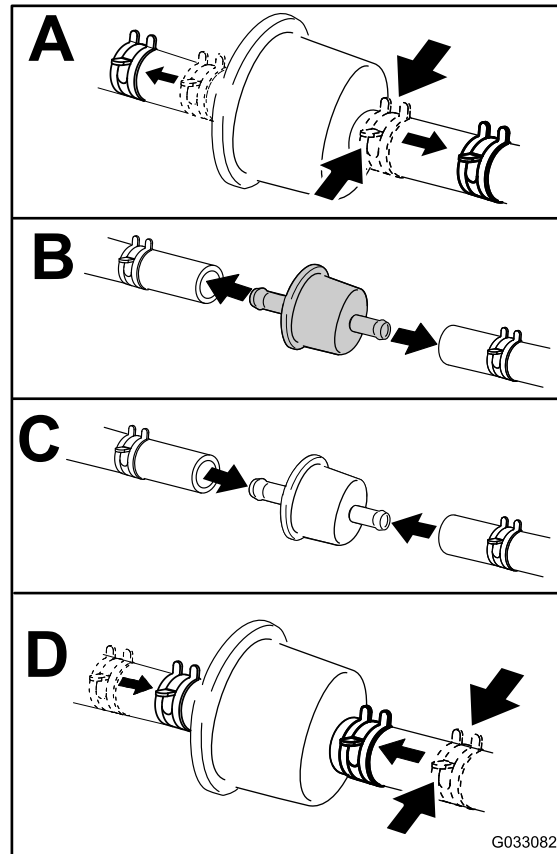

G033082

g033082

**Figure 37**

# Electrical System Maintenance

## Electrical System Safety

- Disconnect the battery before repairing the machine. Disconnect the negative terminal first and the positive last. Connect the positive terminal first and the negative last.
- Charge the battery in an open, well-ventilated area, away from sparks and flames. Unplug the charger before connecting or disconnecting the battery. Wear protective clothing and use insulated tools.

### WARNING

#### CALIFORNIA Proposition 65 Warning

Battery posts, terminals, and related accessories contain lead and lead compounds, chemicals known to the State of California to cause cancer and reproductive harm. Wash hands after handling.

## Charging the Battery

### Removing the Battery

#### ▲ WARNING

Battery terminals or metal tools could short against metal machine components, causing sparks. Sparks can cause the battery gasses to explode, resulting in personal injury.

- When removing or installing the battery, do not allow the battery terminals to touch any metal parts of the machine.
  - Do not allow metal tools to short between the battery terminals and metal parts of the machine.
1. Park the machine on a level surface and disengage the blade-control switch.
  2. Engage the parking brake, shut off the engine, remove the key, and wait for all moving parts to stop before leaving the operating position.
  3. Raise the seat to access the battery.
  4. Disconnect the negative (black) ground cable from the battery post (Figure 38). Retain all fasteners.

#### ▲ WARNING

Incorrect battery cable routing could damage the machine and cables causing sparks. Sparks can cause the battery gasses to explode, resulting in personal injury.

- Always disconnect the negative (black) battery cable before disconnecting the positive (red) cable.
  - Always connect the positive (red) battery cable before connecting the negative (black) cable.
5. Slide the rubber cover up the positive (red) cable. Disconnect the positive (red) cable from the battery post (Figure 38). Retain all fasteners.
  6. Remove the battery hold-down and lift the battery from the battery tray (Figure 38).

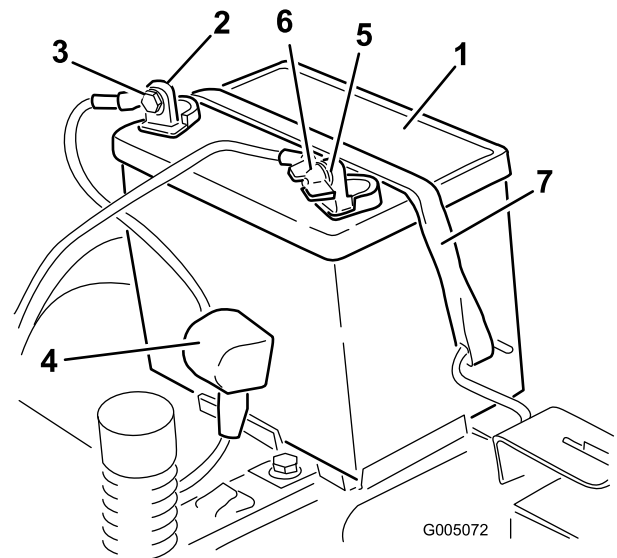

Figure 38

- |                          |                               |
|--------------------------|-------------------------------|
| 1. Battery               | 5. Negative battery post      |
| 2. Positive battery post | 6. Wing nut, washer, and bolt |
| 3. Bolt, washer, and nut | 7. Battery hold-down          |
| 4. Terminal boot         |                               |

## Charging the Battery

**Service Interval:** Before storage—Charge the battery and disconnect battery cables.

1. Remove the battery from the chassis; refer to [Removing the Battery](#) (page 33).
  2. Charge the battery for a minimum of 1 hour at 6 to 10 A.
- Important:** Do not overcharge the battery.
3. When the battery is fully charged, unplug the charger from the electrical outlet, then disconnect the charger leads from the battery posts (Figure 39).

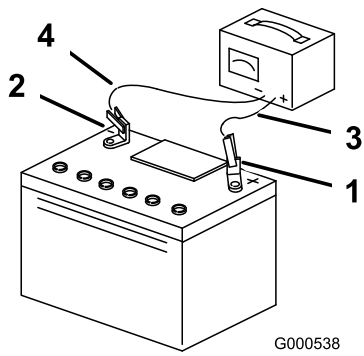

**Figure 39**

- |                          |                           |
|--------------------------|---------------------------|
| 1. Positive battery post | 3. Red (+) charger lead   |
| 2. Negative battery post | 4. Black (-) charger lead |

## Installing the Battery

1. Position the battery in the tray (Figure 38).
2. Install the positive (red) battery cable to the positive (+) battery terminal using the fasteners removed previously.
3. Install the negative battery cable to the negative (-) battery terminal using the fasteners removed previously.
4. Slide the red terminal boot onto the positive (red) battery post.
5. Secure the battery with the hold-down (Figure 38).
6. Lower the seat.

## Servicing the Fuses

The electrical system is protected by fuses. It requires no maintenance; however, if a fuse blows, check the component/circuit for a malfunction or short.

### Fuse type:

- Main—F1 (30 A, blade-type)
- Charge Circuit—F2 (25 A, blade-type)

1. Remove the screws securing the control panel to the machine.

**Note:** Retain all fasteners.

2. Lift the control pane up to access the main wire harness and fuse block (Figure 40).
3. To replace a fuse, pull out on the fuse to remove it (Figure 40).

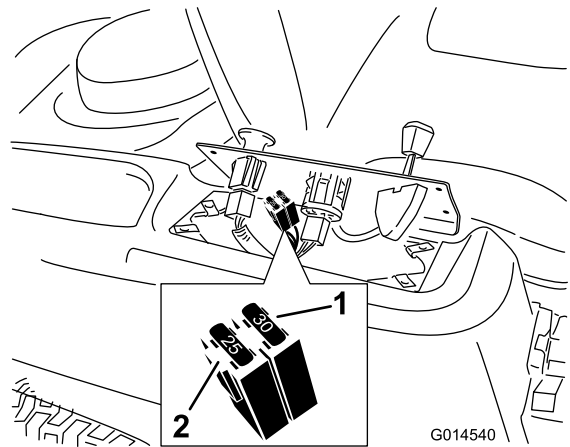

**Figure 40**

- |                |                          |
|----------------|--------------------------|
| 1. Main (30 A) | 2. Charge circuit (25 A) |
|----------------|--------------------------|

4. Return the control panel to its original position.

**Note:** Use the screws removed previously to secure the panel to the machine.

# Drive System Maintenance

## Checking the Tire Pressure

**Service Interval:** Every 25 hours—Check tire pressure.

Maintain the air pressure in the front and rear tires as specified. Uneven tire pressure can cause uneven cut. Check the pressure at the valve stem (Figure 41). Check the tires when they are cold to get the most accurate pressure reading.

Refer to the maximum pressure suggested by the tire manufacturer on the sidewall of the caster wheel tires.

Inflate the rear drive wheel tires to 90 kPa (13 psi).

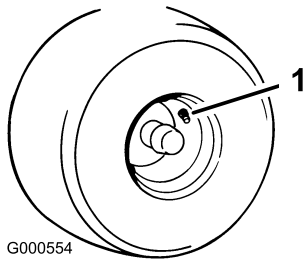

**Figure 41**

1. Valve stem

## Releasing the Electric Brake

You can manually release the electric brake by rotating the link arms forward. Once the electric brake is energized, the brake resets.

1. Turn the ignition key to the OFF position or disconnect the battery.
2. Locate the shaft on the electric brake where the brake link arms are connected (Figure 42).
3. Rotate the shaft forward to release the brake.

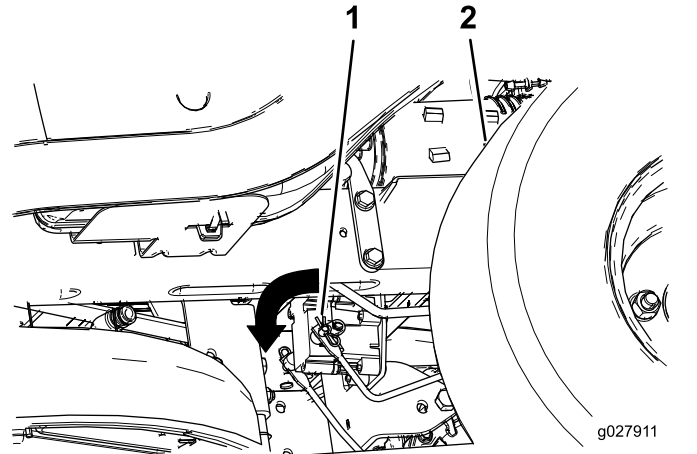

**Figure 42**

1. Brake-link arm on the electric brake control module
2. Left, rear tire

# Mower Maintenance

## Servicing the Cutting Blades

To ensure a superior quality of cut, keep the blades sharp. For convenient sharpening and replacement, keep extra blades on hand.

### Blade Safety

A worn or damaged blade can break, and a piece of the blade could be thrown toward you or bystanders, resulting in serious personal injury or death. Trying to repair a damaged blade may result in discontinued safety certification of the product.

- Inspect the blades periodically for wear or damage.
- Use care when checking the blades. Wrap the blades or wear gloves, and use caution when servicing the blades. Only replace or sharpen the blades; never straighten or weld them.
- On multi-bladed machines, take care as rotating 1 blade can cause other blades to rotate.

### Before Inspecting or Servicing the Blades

Park the machine on a level surface, disengage the blade-control switch, engage the parking brake, shut off the engine, and remove the key.

### Inspecting the Blades

**Service Interval:** Before each use or daily

1. Inspect the cutting edges (Figure 43).
2. If the edges are not sharp or have nicks, remove and sharpen the blade; refer to [Sharpening the Blades](#) (page 37).
3. Inspect the blades, especially in the curved area.
4. If you notice any cracks, wear, or a slot forming in this area, immediately install a new blade (Figure 43).

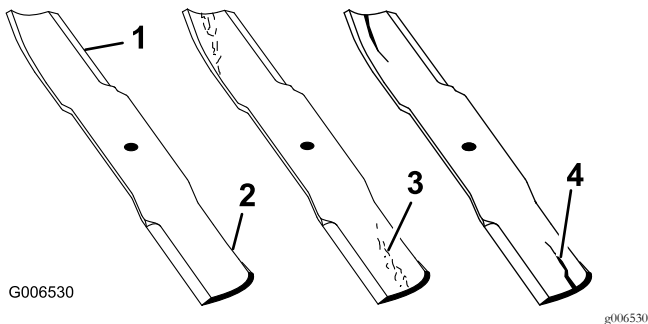

Figure 43

1. Cutting edge
2. Curved area
3. Wear/slot forming
4. Crack

## Checking for Bent Blades

**Note:** The machine must be on a level surface for the following procedure.

1. Raise the mower deck to the highest height-of-cut position.
2. While wearing thickly padded gloves, or other adequate hand protection, slowly rotate the blade to be measure into a position that allows effective measurement of the distance between the cutting edge and the level surface the machine is on (Figure 44).

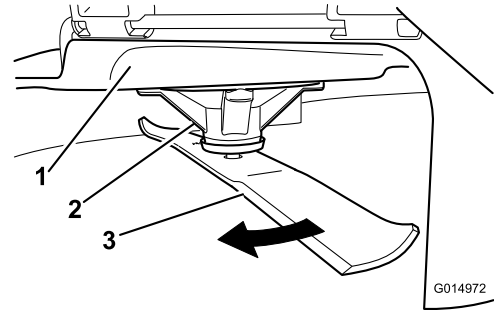

Figure 44

1. Deck
2. Spindle housing
3. Blade

3. Measure from the tip of the blade to the flat surface (Figure 45).

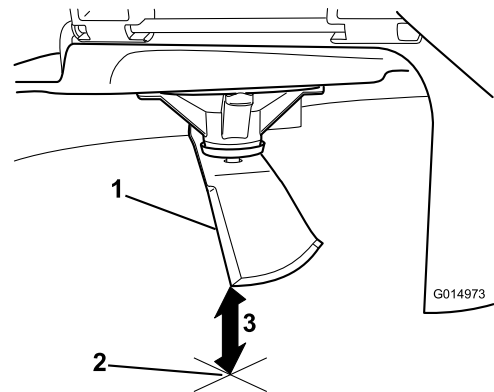
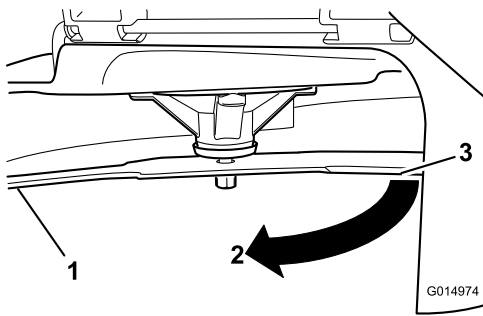

Figure 45

1. Blade (in position for measuring)
2. Level surface
3. Measured distance between blade and the surface (A)

4. Rotate the same blade 180 degrees so that the opposing cutting edge is now in the same position (Figure 46).

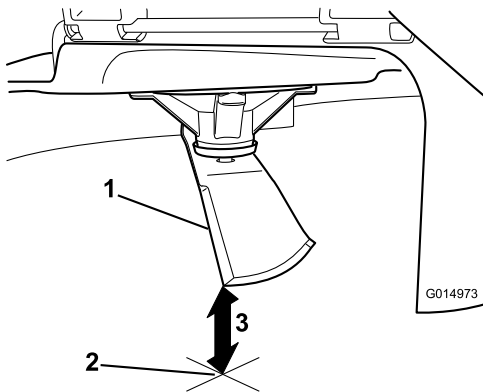

**Figure 46**

1. Blade (side previously measured)
2. Measurement (position used previously)
3. Opposing side of blade being moved into measurement position

5. Measure from the tip of the blade to the flat surface (Figure 47).

**Note:** The variance should be no more than 3 mm (1/8 inch).



**Figure 47**

1. Opposite blade edge (in position for measuring)
2. Level surface
3. Second measured distance between blade and surface (B)

- A. If the difference between A and B is greater than 3 mm (1/8 inch), replace the blade with a new blade; refer to [Removing the Blades](#) (page 37) and [Installing the Blades](#) (page 38).

**Note:** If a bent blade is replaced with a new blade, and the dimension obtained continues to exceed 3 mm (1/8 inch), the blade spindle could be bent. Contact an Authorized Toro Dealer for service.

- B. If the variance is within constraints, move to the next blade.

6. Repeat this procedure on each blade.

## Removing the Blades

Replace the blades if they hit a solid object, or if the blade is out of balance or bent.

1. Hold the blade end using a rag or thickly padded glove.
2. Remove the blade bolt, curved washer, and blade from the spindle shaft (Figure 48).

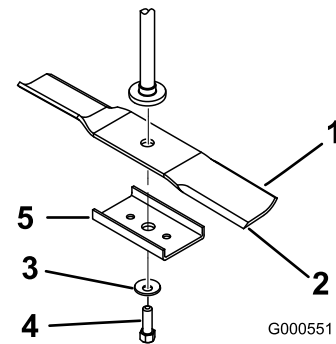

**Figure 48**

- |                           |                    |
|---------------------------|--------------------|
| 1. Sail area of the blade | 4. Blade bolt      |
| 2. Blade                  | 5. Blade stiffener |
| 3. Curved washer          |                    |

## Sharpening the Blades

1. Use a file to sharpen the cutting edge at both ends of the blade (Figure 49).

**Note:** Maintain the original angle.

**Note:** The blade retains its balance if the same amount of material is removed from both cutting edges.

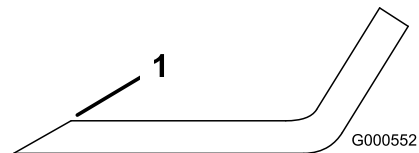
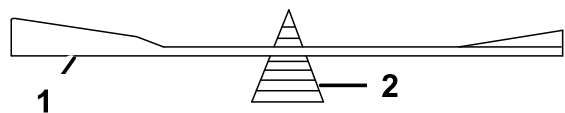

**Figure 49**

1. Sharpen at original angle.
2. Check the balance of the blade by putting it on a blade balancer (Figure 50).

**Note:** If the blade stays in a horizontal position, the blade is balanced and can be used.

**Note:** If the blade is not balanced, file some metal off the end of the sail area only (Figure 49).



**Figure 50**

1. Blade
2. Balancer

- Repeat this procedure until the blade is balanced.

## Installing the Blades

- Install the blade onto the spindle shaft (Figure 48).

**Important:** The curved part of the blade must point upward toward the inside of the mower to ensure proper cutting.

- Install the curved washer (cupped side toward the blade) and the blade bolt (Figure 48).
- Torque the blade bolt to 47 to 88 N·m (35 to 65 ft-lb).

## Leveling the Mower Deck

Check to ensure that the mower deck is level any time you install the mower or when you see an uneven cut on your lawn.

The mower deck must be checked for bent blades prior to leveling; any bent blades must be removed and replaced; refer to [Checking for Bent Blades \(page 36\)](#) before continuing.

The mower deck must be leveled side-to-side first then the front to rear slope can be adjusted.

### Requirements:

- The machine must be on a level surface.
- All 4 tires must be properly inflated; refer to [Checking the Tire Pressure \(page 35\)](#).

## Leveling from Side to Side

- Park the machine on a level surface and disengage the blade-control switch.
- Engage the parking brake, shut off the engine, remove the key, and wait for all moving parts to stop before leaving the operating position.
- Set the height-of-cut lever to the middle position.
- Carefully rotate the blade so that it is side to side (Figure 51).

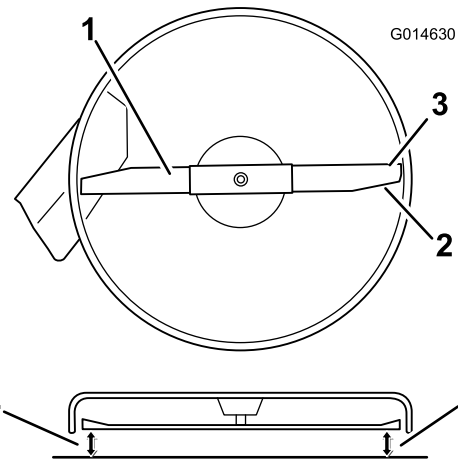

Figure 51

- Blade side to side
- Sail area of the blade
- Outside cutting edges
- Measure from the tip of the blade to the flat surface here

- Measure between the outside cutting edges and the flat surface (Figure 51).

**Note:** If both measurements are not within 5 mm (3/16 inch), an adjustment is required; continue with this procedure.

- Move to the left side of the machine.
- Loosen the side locking nut.
- Raise or lower the left side of the mower deck by rotating the rear nut (Figure 52).

**Note:** Rotate the rear nut clockwise to raise the mower deck; rotate the rear nut counter-clockwise to lower the mower deck.

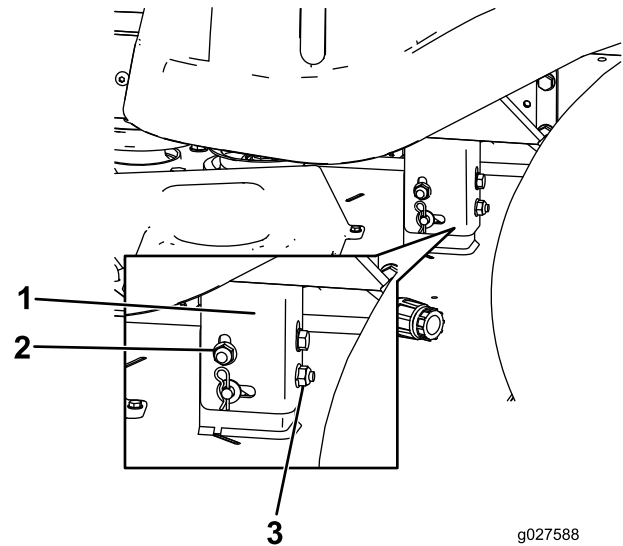

Figure 52

- Hanger bracket
- Side locking nut
- Rear nut

9. Check the side-to-side adjustments again. Repeat this procedure until the measurements are correct.
10. Continue leveling the deck by checking the front-to-rear blade slope; refer to [Adjusting the Front-to-Rear Blade Slope](#) (page 39).

## Adjusting the Front-to-Rear Blade Slope

Check the front-to-rear blade slope any time you install the mower. If the front of the mower is more than 7.9 mm (5/16 inch) lower than the rear of the mower, adjust the blade level using the following instructions:

1. Park the machine on a level surface and disengage the blade-control switch.
2. Engage the parking brake, shut off the engine, remove the key, and wait for all moving parts to stop before leaving the operating position.
3. Set the height-of-cut lever to middle position.

**Note:** Check and adjust the side-to-side blade level if you have not checked the setting; refer to [Leveling from Side to Side](#) (page 38).

4. Carefully rotate the blades so they are facing front to rear ([Figure 53](#)).

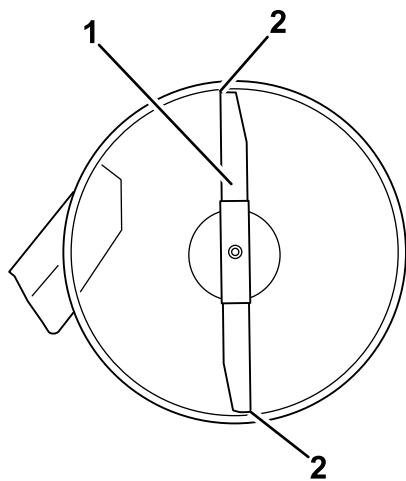

G014631

g014631

**Figure 53**

Mower decks with 1 blade

1. Blade front to rear
  2. Measure from the tip of the blade to the flat surface here.
- 
5. Measure from the tip of the front blade to the flat surface and the tip of the rear blade to the flat surface ([Figure 53](#)).
- Note:** If the front blade tip is not 1.6 to 7.9 mm (1/16 to 5/16 inch) lower than the rear blade tip, adjust the front locknut.
6. To adjust the front-to-rear blade slope, rotate the adjustment nut in the front of the mower ([Figure 54](#)).

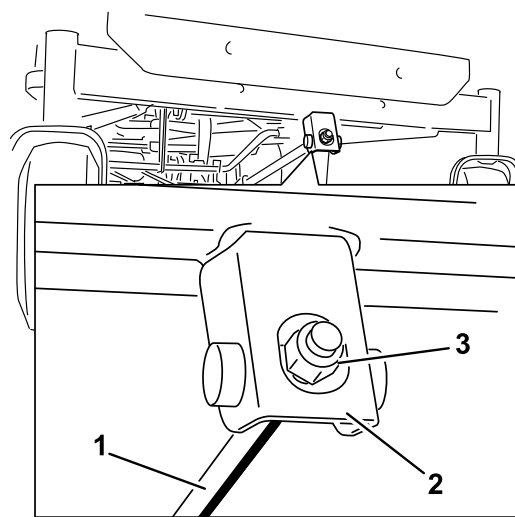

G014634

g014634

**Figure 54**

1. Adjusting rod
2. Adjusting block
3. Locknut

7. To raise the front of the mower, tighten the adjustment nut.
8. To lower the front of the mower, loosen the adjustment nut.
9. After adjustment, check the front-to-rear slope again, continue adjusting the nut until the front blade tip is 1.6 to 7.9 mm (1/16 to 5/16 inch) lower than the rear blade tip ([Figure 53](#)).
10. When the front-to-rear blade slope is correct check the side-to-side level of the mower again; refer to [Leveling from Side to Side](#) (page 38).

## Removing the Mower Deck

1. Park the machine on a level surface and disengage the blade-control switch.
2. Engage the parking brake, shut off the engine, remove the key, and wait for all moving parts to stop before leaving the operating position.
3. Lower the height-of-cut lever to the lowest position.
4. Remove the hairpin cotter from the front support rod and remove the rod from the deck bracket ([Figure 55](#)). Carefully lower the front of the mower deck to the ground.

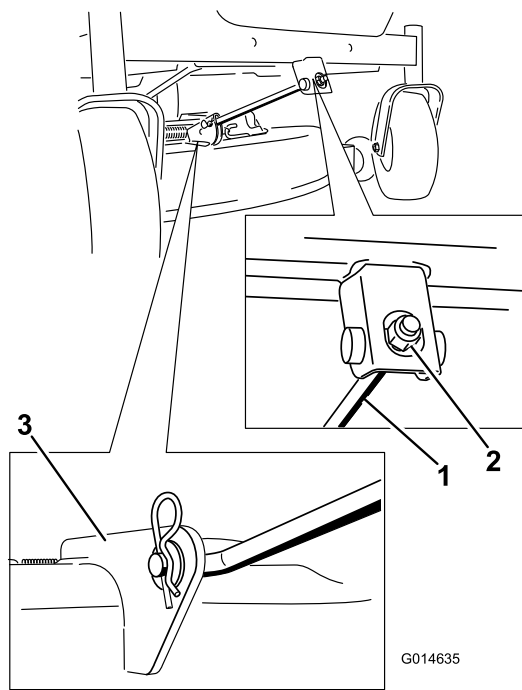

**Figure 55**

1. Front support rod
2. Locking nut
3. Deck bracket

5. Using the mower-deck handles, lift the mower deck and hanger brackets clear of the rear lift rod and lower the mower carefully to the ground (Figure 56).

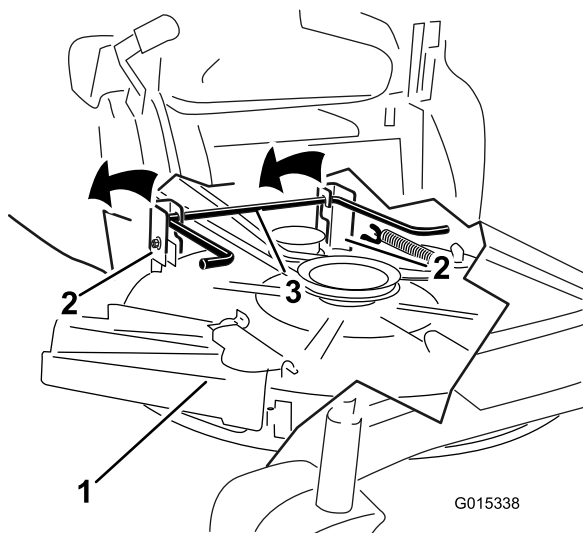

**Figure 56**

1. Mower deck
2. Hanger bracket
3. Rear lift rod

6. Slide the mower deck rearward to remove the mower belt from the engine pulley.
7. Slide the mower deck out from underneath the machine.

**Note:** Retain all parts for future installation.

## Installing the Mower Deck

1. Park the machine on a level surface and disengage the blade-control switch.
2. Engage the parking brake, shut off the engine, remove the key, and wait for all moving parts to stop before leaving the operating position.
3. Slide the mower under the machine.
4. Lower the height-of-cut lever to the lowest position.
5. Lift the rear of the mower deck and guide the hanger brackets over the rear lift rod (Figure 56).
6. Attach the front support rod to the mower deck with the clevis pin and hairpin cotter (Figure 55).
7. Install the mower belt onto the engine pulley; refer to Replacing the Mower Belt (page 41).

## Replacing the Grass Deflector

**Service Interval:** Before each use or daily—Inspect the grass deflector for damage.

### **⚠ WARNING**

An uncovered discharge opening could allow the lawn mower to throw objects in the operator's or bystander's direction and result in serious injury. Also, contact with the blade could occur. Never operate the machine without the grass deflector, the discharge cover, or the grass-collection system in place.

Never operate the machine without the grass deflector, the discharge cover, or the grass-collection system in place.

1. Remove the nut (3/8 inch) from the rod under the mower (Figure 57).

# Mower Belt Maintenance

## Inspecting the Belts

**Service Interval:** Every 25 hours—Check the belts for wear or cracks.

Check the belts for cracks, frayed edges, burn marks, or any other damage. Replace damaged belts.

## Replacing the Mower Belt

Squealing when the belt is rotating, blades slipping when cutting grass, frayed belt edges, burn marks, and cracks are signs of a worn mower belt. Replace the mower belt if any of these conditions are evident.

1. Park the machine on a level surface and disengage the blade-control switch.
2. Engage the parking brake, shut off the engine, remove the key, and wait for all moving parts to stop before leaving the operating position.
3. Set the height of cut at the lowest cutting position of 38 mm (1-1/2 inches).
4. Using a spring-removal tool (Toro Part No. 92-5771), remove the idler spring from the deck hook to remove tension on the idler pulley, and roll the belt off of the pulleys (Figure 58).

### **▲ WARNING**

**The spring is under tension when installed and can cause personal injury.**

**Be careful when removing the belt.**

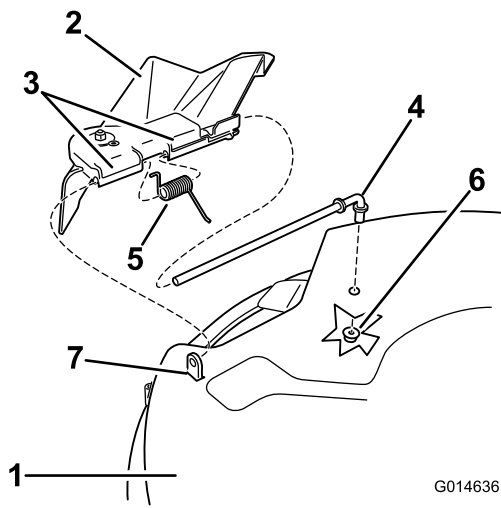

G014636

g014636

**Figure 57**

- |                            |                   |
|----------------------------|-------------------|
| 1. Mower deck              | 5. Spring         |
| 2. Grass deflector         | 6. Nut (3/8 inch) |
| 3. Grass-deflector bracket | 7. Short standoff |
| 4. Rod                     |                   |

2. Slide the rod out of the short stand-off, spring, and grass deflector (Figure 57).
3. Remove the damaged or worn grass deflector.
4. Replace the grass deflector (Figure 57).
5. Slide the rod, straight end, through the rear grass deflector bracket.
6. Place the spring on the rod, with end wires down, and between the grass deflector brackets.
7. Slide the rod through the second grass-deflector bracket (Figure 57).
8. Insert the rod at the front of the grass deflector into the short standoff on the deck.
9. Secure the rear end of the rod into the mower with a nut (3/8 inch) as shown in Figure 57.

**Important:** The grass deflector must be spring-loaded in the down position. Lift the deflector up to test that it snaps into the full-down position.

# Cleaning

## Cleaning under the Front of the Machine

**Service Interval:** After each use—Check and clean the front of the machine.

Remove debris under the front of the machine with compressed air or by hand with a brush (Figure 59).

**Note:** Do not use water to clean under the front of the machine, this can cause build up of debris.

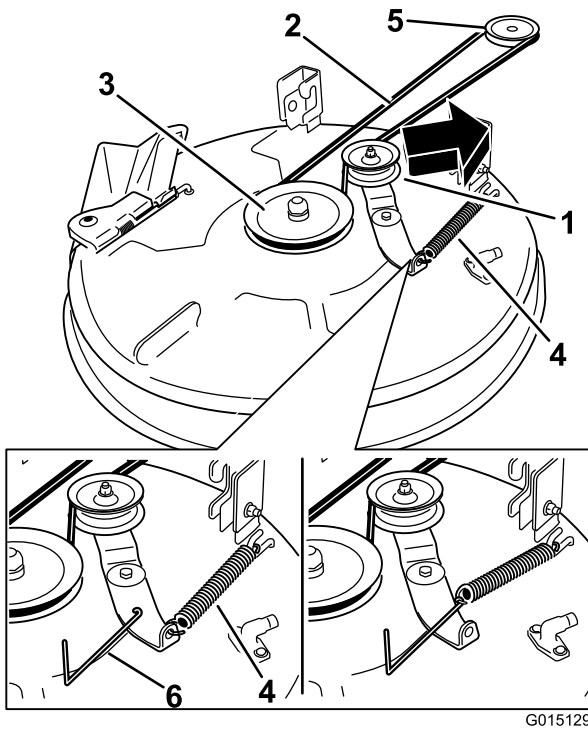

G015129

g015129

**Figure 58**

Mower decks with 1 blade

- |                   |                        |
|-------------------|------------------------|
| 1. Idler pulley   | 4. Spring              |
| 2. Mower belt     | 5. Engine pulley       |
| 3. Outside pulley | 6. Spring-removal tool |

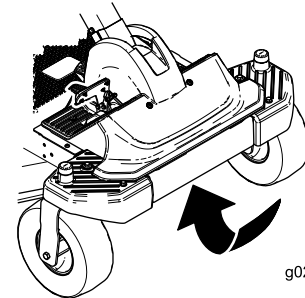

g028248

g028248

**Figure 59**

## Washing the Underside of the Mower

**Service Interval:** After each use—Clean the mower-deck housing.

**Important:** You can wash the machine with a mild detergent and water. Do not pressure wash the machine. Avoid excessive use of water, especially near the control panel, under the seat, around the engine, hydraulic pumps, and motors.

Wash the underside of the mower after each use to prevent grass buildup for improved mulch action and clipping dispersal.

1. Park the machine on a level surface and disengage the blade-control switch.
2. Ensure that the parking brake is engaged, shut off the engine, remove the key, and wait for all moving parts to stop before leaving the operating position.
3. Attach the hose coupling to the end of the mower washout fitting, and turn the water on high (Figure 60).

**Note:** Spread petroleum jelly on the washout fitting O-ring to make the coupling slide on easier and protect the O-ring.

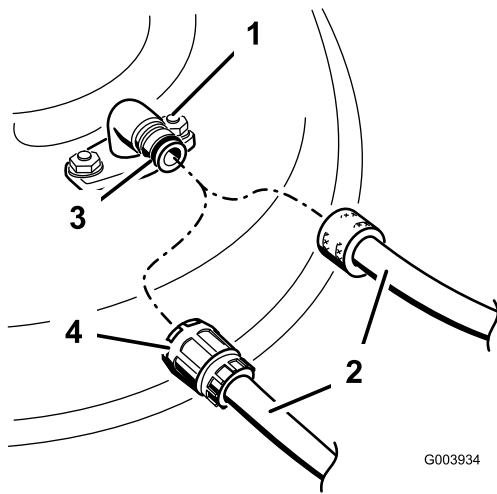

Figure 60

- |                    |             |
|--------------------|-------------|
| 1. Washout fitting | 3. O-ring   |
| 2. Hose            | 4. Coupling |

4. Lower the mower to the lowest height-of-cut.
5. Sit on the seat and start the engine.
6. Engage the blade-control switch and let the mower run for 1 to 3 minutes.
7. Disengage the blade-control switch, shut off the engine, remove the ignition key, and wait for all moving parts to stop.
8. Turn the water off and remove the coupling from the washout fitting.

**Note:** If the mower is not clean after 1 washing, soak it and let it stand for 30 minutes. Then, repeat the process.

9. Run the mower again for 1 to 3 minutes to remove excess water.

### ⚠ WARNING

**A broken or missing washout fitting could expose you and others to thrown objects or blade contact. Contact with a blade or thrown debris can cause injury or death.**

- **Replace broken or missing washout fitting immediately, before using mower again.**
- **Never put your hands or feet under the mower or through openings in the mower.**

# Storage

## Cleaning and Storage

1. Disengage the blade-control switch, shut off the engine, and remove the key.
2. Remove grass clippings, dirt, and grime from the external parts of the entire machine, especially the engine. Clean dirt and chaff from the outside of the engine cylinder head fins and blower housing.

**Important:** You can wash the machine with mild detergent and water. Do not pressure wash the machine. Avoid excessive use of water, especially near the control panel, under the seat, around the engine, hydraulic pumps, and motors.

3. Service the air cleaner; refer to [Servicing the Air Cleaner](#) (page 27).
4. Grease and oil the machine; refer to [Lubrication](#) (page 27).
5. Change the crankcase oil and filter; refer to [Changing the Engine Oil and Filter](#) (page 29).
6. Check the tire pressure; refer to [Checking the Tire Pressure](#) (page 35).
7. Charge the battery; refer to [Charging the Battery](#) (page 33).
8. Check the condition of the blades; refer to [Servicing the Cutting Blades](#) (page 36).
9. Prepare the machine for storage when non-use occurs over 30 days. Prepare the machine for storage as follows.
10. Add a petroleum based stabilizer/conditioner to the fuel in the tank. Follow the mixing instructions from the stabilizer manufacturer. Do not use an alcohol based stabilizer (ethanol or methanol).

**Note:** A fuel stabilizer/conditioner is most effective when mixed with fresh gasoline and used at all times.

Run the engine to distribute the conditioned fuel through the fuel system (5 minutes).

**Important:** Do not store gasoline with stabilizer/conditioner over 90 days.

11. Remove the spark plug(s) and check its condition; refer to [Checking the Spark Plug](#) (page 31). With the spark plug(s) removed from the engine, pour 2 tablespoons of engine oil into the spark plug hole. Use the starter to crank the engine and distribute the oil inside the cylinder. Install the spark plug(s). Do not install the wire on the spark plug(s).
12. Clean any dirt and chaff from the top of the mower.
13. Scrape any heavy buildup of grass and dirt from the underside of the mower, then wash the mower with a garden hose.
14. Check the condition of the drive and mower belts.

15. Check and tighten all bolts, nuts, and screws. Repair or replace any part that is worn or damaged.
16. Paint all scratched or bare metal surfaces. Paint is available from your Authorized Service Dealer.
17. Store the machine in a clean, dry garage or storage area. Remove the key from the ignition switch and keep it in a memorable place. Cover the machine to protect it and keep it clean.

# Troubleshooting

Problem	Possible Cause	Corrective Action
The engine overheats.	<ol style="list-style-type: none"> <li>1. The engine load is excessive.</li> <li>2. The oil level in the crankcase is low.</li> <li>3. The cooling fins and air passages under the engine blower housing are plugged.</li> <li>4. The air cleaner is dirty.</li> <li>5. Dirt, water, or stale fuel is in fuel system.</li> </ol>	<ol style="list-style-type: none"> <li>1. Reduce ground speed.</li> <li>2. Add oil to the crankcase.</li> <li>3. Remove the obstruction from the cooling fins and air passages.</li> <li>4. Clean or replace the air-cleaner element.</li> <li>5. Contact an Authorized Service Dealer</li> </ol>
The starter does not crank.	<ol style="list-style-type: none"> <li>1. The blade-control switch is engaged.</li> <li>2. The battery is dead.</li> <li>3. The electrical connections are corroded or loose.</li> <li>4. A fuse is blown.</li> <li>5. A relay or switch is damaged.</li> </ol>	<ol style="list-style-type: none"> <li>1. Disengage the blade-control switch.</li> <li>2. Charge the battery.</li> <li>3. Check the electrical connections for good contact.</li> <li>4. Replace the fuse.</li> <li>5. Contact an Authorized Service Dealer.</li> </ol>
The engine does not start, starts hard, or fails to keep running.	<ol style="list-style-type: none"> <li>1. The fuel tank is empty.</li> <li>2. The choke is not on.</li> <li>3. The air cleaner is dirty.</li> <li>4. The spark-plug wire(s) is loose or disconnected.</li> <li>5. The spark plug(s) is pitted, fouled, or the gap is incorrect.</li> <li>6. There is dirt in fuel filter.</li> <li>7. Dirt, water, or stale fuel is in fuel system.</li> <li>8. There is incorrect fuel in the fuel tank.</li> <li>9. The oil level in the crankcase is low.</li> </ol>	<ol style="list-style-type: none"> <li>1. Fill the fuel tank.</li> <li>2. Move the choke lever to the ON position.</li> <li>3. Clean or replace the air-cleaner element.</li> <li>4. Install the wire(s) on the spark plug.</li> <li>5. Install a new, correctly gapped spark plug(s).</li> <li>6. Replace the fuel filter.</li> <li>7. Contact an Authorized Service Dealer.</li> <li>8. Drain the tank and replace the fuel with the proper type.</li> <li>9. Add oil to the crankcase.</li> </ol>
The engine loses power.	<ol style="list-style-type: none"> <li>1. The engine load is excessive.</li> <li>2. The air cleaner is dirty.</li> <li>3. The oil level in the crankcase is low.</li> <li>4. The cooling fins and air passages under the engine blower housing are plugged.</li> <li>5. The spark plug(s) is pitted, fouled, or the gap is incorrect.</li> <li>6. The fuel tank vent is blocked.</li> <li>7. There is dirt in the fuel filter.</li> <li>8. Dirt, water, or stale fuel is in the fuel system.</li> <li>9. There is incorrect fuel in the fuel tank.</li> </ol>	<ol style="list-style-type: none"> <li>1. Reduce ground speed.</li> <li>2. Clean the air cleaner element.</li> <li>3. Add oil to the crankcase.</li> <li>4. Remove the obstruction from the cooling fins and air passages.</li> <li>5. Install a new, correctly gapped spark plug(s).</li> <li>6. Contact an Authorized Service Dealer.</li> <li>7. Replace the fuel filter.</li> <li>8. Contact an Authorized Service Dealer.</li> <li>9. Drain the tank and replace the fuel with the proper type.</li> </ol>
The machine does not drive.	<ol style="list-style-type: none"> <li>1. The bypass valves are open.</li> <li>2. The traction belts are worn, loose, or broken.</li> <li>3. The traction belts are off of the pulleys.</li> <li>4. The transmission has failed.</li> </ol>	<ol style="list-style-type: none"> <li>1. Close the tow valves.</li> <li>2. Contact an Authorized Service Dealer.</li> <li>3. Contact an Authorized Service Dealer.</li> <li>4. Contact an Authorized Service Dealer.</li> </ol>

Problem	Possible Cause	Corrective Action
There is abnormal vibration.	<ol style="list-style-type: none"> <li>1. The engine mounting bolts are loose.</li> <li>2. The engine pulley, idler pulley, or blade pulley is loose.</li> <li>3. The engine pulley is damaged.</li> <li>4. The cutting blade(s) is/are bent or unbalanced.</li> <li>5. A blade mounting bolt is loose.</li> <li>6. A blade spindle is bent.</li> </ol>	<ol style="list-style-type: none"> <li>1. Tighten the engine mounting bolts.</li> <li>2. Tighten the appropriate pulley.</li> <li>3. Contact an Authorized Service Dealer.</li> <li>4. Install a new cutting blade(s).</li> <li>5. Tighten the blade mounting bolt.</li> <li>6. Contact an Authorized Service Dealer.</li> </ol>
The cutting height is uneven.	<ol style="list-style-type: none"> <li>1. The blade(s) is not sharp.</li> <li>2. A cutting blade(s) is/are bent.</li> <li>3. The mower is not level.</li> <li>4. An anti-scalp wheel is not set correctly.</li> <li>5. The underside of the mower is dirty.</li> <li>6. The tire pressure is incorrect.</li> <li>7. A blade spindle is bent.</li> </ol>	<ol style="list-style-type: none"> <li>1. Sharpen the blade(s).</li> <li>2. Install a new cutting blade(s).</li> <li>3. Level the mower from side to side and front to rear.</li> <li>4. Adjust the anti-scalp wheel height.</li> <li>5. Clean the underside of the mower.</li> <li>6. Adjust the tire pressure.</li> <li>7. Contact an Authorized Service Dealer.</li> </ol>
The blades do not rotate.	<ol style="list-style-type: none"> <li>1. The drive belt is worn, loose or broken.</li> <li>2. The drive belt is off of the pulley.</li> <li>3. The power takeoff (PTO) switch or PTO clutch is faulty.</li> <li>4. The mower belt is worn, loose, or broken.</li> </ol>	<ol style="list-style-type: none"> <li>1. Install a new drive belt.</li> <li>2. Install the drive belt and check the adjusting shafts and belt guides for the correct position.</li> <li>3. Contact an Authorized Service Dealer.</li> <li>4. Install a new mower belt.</li> </ol>

# Schematics

WIRE COLOR CODES

BK	=	BLACK	PK	=	PINK
BN	=	BROWN	R	=	RED
BU	=	BLUE	T	=	TAN
GN	=	GREEN	VIO	=	VIOLET
GY	=	GREY	W	=	WHITE
OR	=	ORANGE	Y	=	YELLOW
BN/W	=	BROWN w/WHITE			
BU/W	=	BLUE w/WHITE			
GN/W	=	GREEN w/WHITE			
W/BK	=	WHITE w/BLACK			
Y/BK	=	YELLOW w/BLACK			
VIO/BK	=	VIOLET w/BLACK			

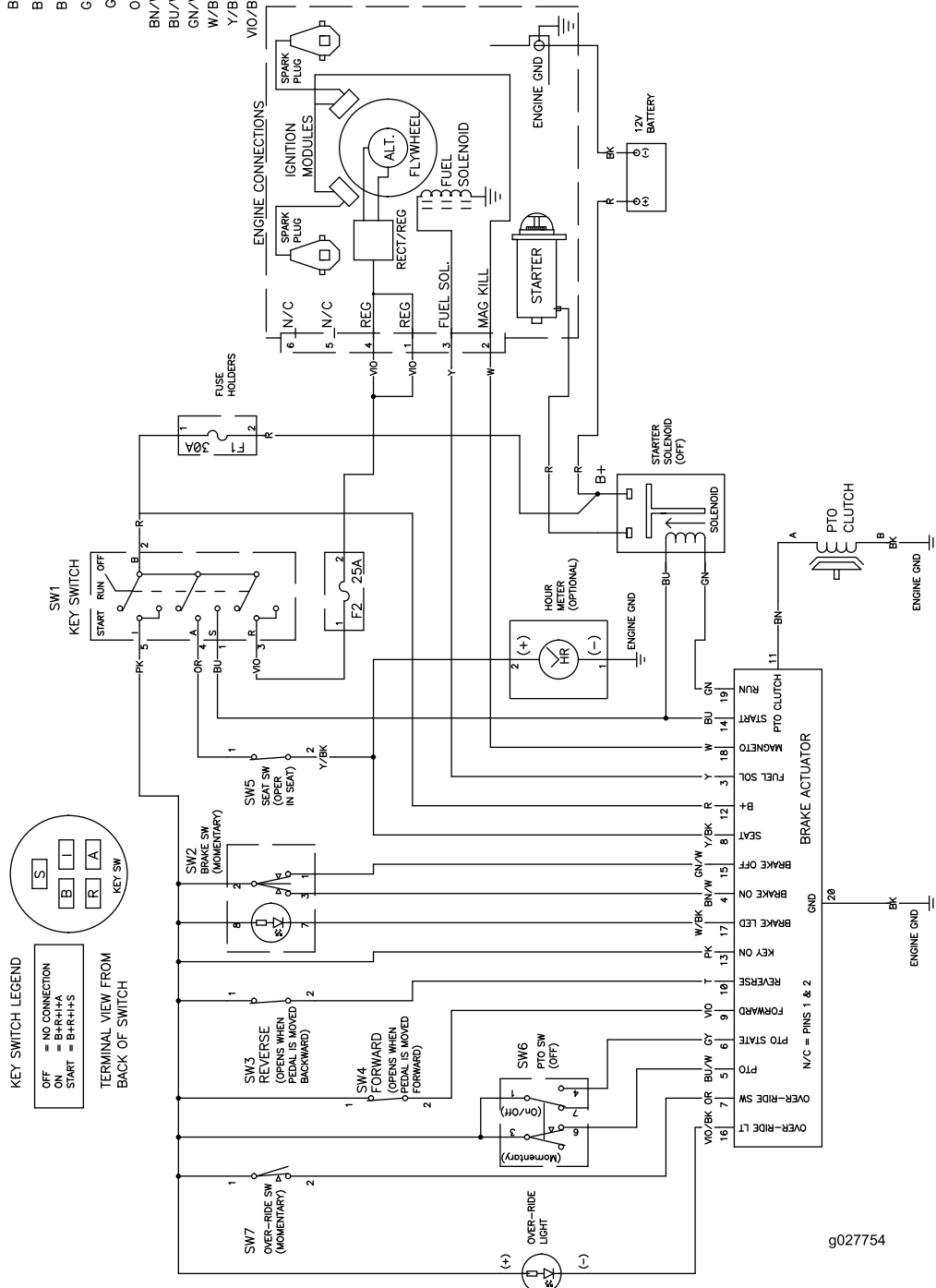

g027754

Electrical Diagram (Rev. A)

g027754



## The Toro Warranty

Limited Warranty (see warranty periods below)

### Conditions and Products Covered

The Toro Company and its affiliate, Toro Warranty Company, pursuant to an agreement between them, jointly promise to repair the Toro Products listed below if defective in materials or workmanship.

The following time periods apply from the original date of purchase:

Products	Warranty Period
TimeCutter Mowers • Engines <sup>1</sup> — Residential use	Residential Use <sup>2</sup> – 3 years Kawasaki – 3 years Kohler – 3 years Toro – 3 years
TimeCutter Mowers • Engines <sup>1</sup> — Commercial use	Commercial use 30 days Kawasaki – 3 years Kohler – 90 days Toro – 2 years / 300 Hours <sup>3</sup>
TimeCutter HD Mowers • Engines <sup>1</sup> — Residential and Commercial Use	3 years or 300 Hours <sup>3</sup> 3 years or 300 Hours <sup>3</sup>
<b>All Mowers</b>	
• Attachments	1 year
• Battery	90 days Parts and Labor 1 year Parts only
• Belts and Tires	90 days

<sup>1</sup>Some engines used on Toro Products are warranted by the engine manufacturer.

<sup>2</sup>Residential use means use of the product on the same lot as your home. Use at more than one location is considered commercial use and the commercial use warranty would apply.

<sup>3</sup>Whichever occurs first.

Warranty may be denied if the hour meter is disconnected, altered, or shows signs of being tampered with.

### Owner Responsibilities

You must maintain your Toro Product by following the maintenance procedures described in the *Operator's Manual*. Such routine maintenance, whether performed by a dealer or by you, is at your expense.

### Instructions for Obtaining Warranty Service

If you think that your Toro Product contains a defect in materials or workmanship, follow this procedure:

- Contact any Authorized Toro Service Dealer to arrange service at their dealership. To locate a dealer convenient to you, access our web site at [www.Toro.com](http://www.Toro.com). You may also call the numbers listed in item #3 to use the 24-hour Toro Dealer locator system.
- Bring the product and your proof of purchase (sales receipt) to the Service Dealer. The dealer will diagnose the problem and determine if it is covered under warranty.

- If for any reason you are dissatisfied with the Service Dealer's analysis or with the assistance provided, contact us at:

Toro Warranty Company  
Customer Care Department, RLC Division  
8111 Lyndale Avenue South  
Bloomington, MN 55420-1196  
Toll free at 866-216-6029 (U.S. customers)  
Toll free at 866-216-6030 (Canadian customers)

### Items and Conditions Not Covered

There is no other express warranty except for special emission system coverage and engine warranty coverage on some products. This express warranty does not cover the following:

- Cost of regular maintenance service or parts, such as filters, fuel, lubricants, oil changes, spark plugs, air filters, blade sharpening or worn blades, cable/linkage adjustments, or brake and clutch adjustments
- Components failing due to normal wear
- Any product or part which has been altered, misused, neglected, requires replacement or repair due to accidents or lack of proper maintenance
- Pickup and delivery charges
- Repairs or attempted repairs by anyone other than an Authorized Toro Service Dealer
- Repairs necessary due to failure to follow recommended fuel procedure (consult *Operator's Manual* for more details)
  - Removing contaminants from the fuel system is not covered
  - Use of old fuel (more than one month old) or fuel which contains more than 10% ethanol or more than 15% MTBE
  - Failure to drain the fuel system prior to any period of non-use over one month

### General Conditions

All repairs covered by these warranties must be performed by an Authorized Toro Service Dealer using Toro approved replacement parts.

**Neither The Toro Company nor Toro Warranty Company is liable for indirect, incidental or consequential damages in connection with the use of the Toro Products covered by this warranty, including any cost or expense of providing substitute equipment or service during reasonable periods of malfunction or non-use pending completion of repairs under this warranty.**

**All implied warranties of merchantability (that the product is fit for ordinary use) and fitness for use (that the product is fit for a particular purpose) are limited to the duration of the express warranty.**

**Some states do not allow exclusions of incidental or consequential damages, or limitations on how long an implied warranty lasts, so the above exclusions and limitations may not apply to you.**

This warranty gives you specific legal rights, and you may also have other rights which vary from state to state.

### Countries Other than the United States or Canada

This warranty is not valid in Mexico. Customers who have purchased Toro products outside the United States or Canada should contact their Toro Distributor (Dealer) to obtain guarantee policies for your country, province, or state. If for any reason you are dissatisfied with your Distributor's service or have difficulty obtaining guarantee information, contact the Toro importer. If all other remedies fail, you may contact us at Toro Warranty Company.

**Australian Consumer Law:** Australian customers will find details relating to the Australian Consumer Law either inside the box or at your local Toro Dealer.