



MODEL NO. 09120—60001 & UP

OPERATOR'S
MANUAL**GREENS AERATOR**

To assure maximum safety, optimum performance, and gain knowledge of the product, it is essential that you or any other operator read and understand the contents of this manual before the engine is ever started. Pay particular attention to the **SAFETY INSTRUCTIONS** highlighted by this symbol—



The safety alert symbol means **CAUTION, WARNING** or **DANGER**—personal safety instruction. Failure to comply with the instruction may result in personal injury.



Foreword

The Greens Aerator has advanced concepts in engineering, design and safety; and if maintained properly, will give excellent service.

Since this is a high-quality product, Toro is concerned about the future use of the machine and safety of the user. Therefore, read this manual to familiarize yourself with proper set-up, operation and maintenance instructions. The major sections of the manual are:

1. Safety Instructions
2. Before Operating
3. Operation
4. Lubrication

Certain information in this manual is emphasized. DANGER, WARNING and CAUTION identify personal safety related information. IMPORTANT identifies mechanical information demanding special attention. Be sure to read this directive because it deals with the possibility of damaging a part or parts of the machine. NOTE identifies general information worthy of special attention.

TABLE OF CONTENTS

	Page
Safety Instructions	3
Safety and Instruction Decals	5
Before Operating	7
Check Crankcase Oil	7
Fill Fuel Tank with Gasoline	7
Check Hydraulic System Fluid	8
Controls	9
Operating Instructions	10
Starting/Stopping Engine	10
Install Tines	10
Adjust Coring Depth	11
Check Frame Height	11
Operating Procedure	12
Check Interlock System	12
Override System	13
Training Period	14
Before Aerating	14
Aerating Procedure	14
Transport Operation	14
Inspection and Cleanup After Use .	14
Lubrication	15
Troubleshooting	17

Safety Instructions

This safety alert symbol means CAUTION, WARNING or DANGER — “personal safety instruction.” Read and understand the instruction because it has to do with safety. Failure to comply with the instruction may result in personal injury.

Improper use or maintenance of the machine can result in injury. To reduce the potential for injury, comply with the following safety instructions.

BEFORE OPERATING

1. Read and understand the contents of this Operator’s Manual before operating the machine. Become familiar with all controls and know how to stop quickly. A free replacement manual is available by sending complete Model and Serial Number to:

The Toro Company
8111 Lyndale Avenue South Minneapolis,
Minnesota 55420
2. Do not allow children to operate the machine. Do not allow adults to operate the machine without proper instruction.
3. Before attempting to start engine, disengage the traction drive and move the gear shift to neutral.
4. Remove all debris or other objects that might interfere with operation. Keep all bystanders away from the work area.
5. Keep all shields and safety devices in place. If a shield, safety device or decal is defective or damaged, repair or replace it before resuming operation. Also, tighten any loose nuts, bolts and screws to assure the machine is in safe operating condition.
6. Do not operate the machine while wearing sandals, tennis shoes, sneakers or shorts. Also, do not wear loose fitting clothing that could get caught in moving parts. Always wear long pants and substantial shoes. Wearing safety glasses, safety shoes, ear protection and a helmet is advisable and required by some local ordinances and insurance regulations.
7. Fill the fuel tank with gasoline before starting the engine. Avoid spilling gasoline. Since gasoline is flammable, handle it carefully.

- A. Use an approved gasoline container.
- B. Do not fill the tank while the engine is hot or running,
- C. Do not smoke while handling gasoline.
- D. Fill the fuel tank outdoors and up to about one inch (25 mm) from top of the tank, not the filler neck.
- E. Wipe up any spilled gasoline.

WHILE OPERATING

8. Start the engine when the traction drive is disengaged, and the gear shift lever is in neutral.
9. Do not run the engine in a confined area without adequate ventilation. Exhaust fumes are hazardous and could possibly be deadly.
10. Using the machine demands attention, and to prevent loss of control:
 - A. Use only in daylight or when there is good artificial light.
 - B. Watch for holes or other hidden hazards.
 - C. Do not transport the machine close to a sand trap, ditch, creek or other hazard.
11. If the tines strike a solid object or the machine vibrates abnormally, shut the engine off. Remove the high-tension wire from the spark plug to prevent possibility of accidental starting. Check the coring head and traction unit for damage and defective parts. Repair any damage before restarting the engine and operating the tines. Be sure the tines are in good condition and all bolts are tight.
12. Do not touch the engine or muffler while the engine is running or soon after it is stopped. These areas could be hot enough to cause a burn.
13. Before leaving the operator’s position—behind handle or leaving machine unattended, raise the coring head, raise the lockup brackets, disengage the traction drive, move the gear shift to neutral and shut OFF the engine.

MAINTENANCE

14. Disconnect the high-tension wire from the spark plug to prevent accidental starting of the engine when servicing, adjusting or storing the machine.
15. If the traction unit must be tipped to perform maintenance or an adjustment, drain the gasoline from fuel tank and oil from crankcase.
16. To reduce potential fire hazard, keep the engine free of excessive grease, grass, leaves and accumulations of dirt.
17. Be sure the machine is in safe operating condition by keeping nuts, bolts and screws tight. Check the tine mounting bolts and nuts frequently to be sure they are tightened to specification.
18. If the engine must be running to perform a maintenance adjustment, keep hands, feet, clothing and other parts of the body away from the tines and other moving parts.
19. Make sure all hydraulic line connectors are tight, and all hydraulic hoses and lines are in good condition before applying pressure to the system.
20. Keep body and hands away from pin hole leaks or nozzles that eject hydraulic fluid under high pressure. Use paper or cardboard, not hands, to search for leaks. Hydraulic fluid escaping under pressure can have sufficient force to penetrate skin and do serious damage. If fluid is ejected into the skin it must be surgically removed within a few hours by a doctor familiar with this form of injury or gangrene may result.
21. Before disconnecting or performing any work on the hydraulic system, all pressure in system must be relieved by stopping the engine and lowering the implement to the ground.
22. Do not overspeed the engine by changing governor settings. To be sure of safety and accuracy, have an Authorized TORO Distributor check maximum engine speed with a tachometer.
23. The engine must be shut off before checking oil or adding oil to the crankcase.
24. Allow the engine to cool before storing the machine in any enclosure such as a garage or storage shed. Make sure the fuel tank is empty if the machine is to be stored more than 30 days. Do not store the machine near any open flame or where gasoline fumes may be ignited by a spark. Always store gasoline in a safety approved, red metal container.
25. Perform only those maintenance instructions described in this manual. If major repairs are ever needed or assistance is desired, contact an Authorized Toro Distributor. To ensure optimum performance and safety, always purchase genuine TORO replacement parts and accessories to keep the Toro all TORO. NEVER USE "WILL-FIT" REPLACEMENT PARTS AND ACCESSORIES MADE BY OTHER MANUFACTURERS. Look for the TORO logo to assure genuineness. Using unproved replacement parts and accessories could void the warranty of The Toro Company

Sound & Vibration Levels

Sound Levels

This unit has an equivalent continuous A-weighted sound pressure at the operator ear of: 92 dB(A), based on measurements of identical machines per 84/538/EEC.

This unit has a sound power level of 104 dB(A)/1pW, based on measurements of identical machines per procedures outlined in Directive 79/113/EEC and amendments.

Vibration Level

This unit has a vibration level of 8.0 m/s² at the posterior, based on measurements of identical machines per ISO 2631 procedures.

Symbol Glossary

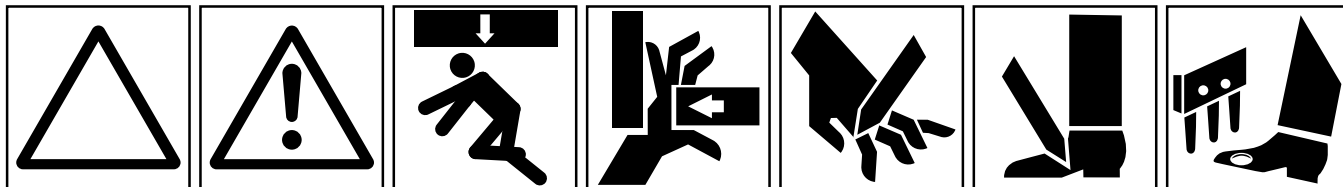

SAFETY ALERT SYMBOL

GENERAL HAZARD SAFETY ALERT

CRUSHING OF WHOLE BODY, APPLIED FROM ABOVE

CRUSHING OF FINGERS OR HAND, FORCE APPLIED FROM SIDE

CUTTING OF FINGERS OR HAND

CUTTING OF FOOT

CRUSHING OR PUNCTURE OF FOOT, CORING HEAD

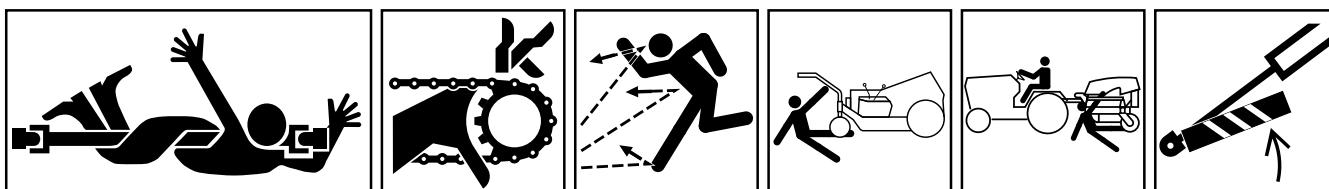

WHOLE BODY ENTANGLEMENT, IMPLEMENT INPUT DRIVE LINE

FINGERS OR HAND ENTANGLEMENT, CHAIN DRIVE

THROWN OR FLYING OBJECTS, WHOLE BODY EXPOSURE

RUNOVER/BACKOVER, GREENS AERATOR

RUNOVER/BACKOVER, HC 4000 AERATOR

SECURE LIFTING CYLINDER WITH LOCKING DEVICE BEFORE GETTING IN HAZARDOUS AREA

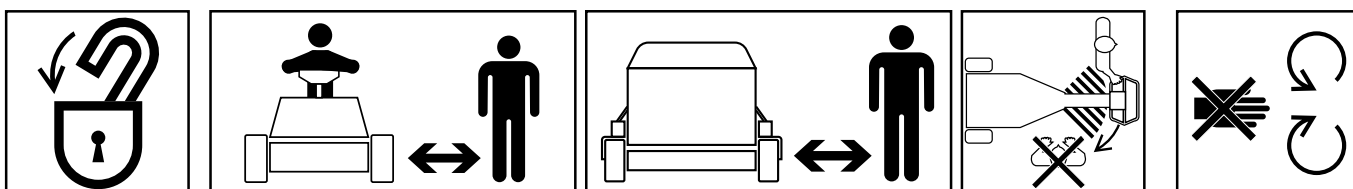

INSERT SAFETY LOCK BEFORE GETTING IN HAZARDOUS AREA

STAY A SAFE DISTANCE FROM MACHINE, GREENS AERATOR

STAY A SAFE DISTANCE FROM MACHINE, HC 4000 AERATOR

STAY CLEAR OF ARTICULATION AREA WHILE ENGINE IS RUNNING, GREENS AERATOR

DO NOT OPEN OR REMOVE SAFETY SHIELDS WHILE ENGINE IS RUNNING

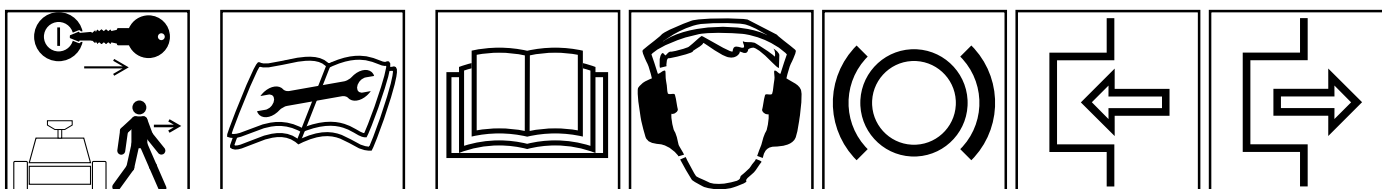

SHUT OFF ENGINE & REMOVE KEY BEFORE LEAVING OPERATOR POSITION, GREENS AERATOR

CONSULT TECHNICAL MANUAL FOR PROPER SERVICE PROCEDURES

READ OPERATOR'S MANUAL

HEARING PROTECTION MUST BE WORN

BRAKE SYSTEM

ENGAGE

DISENGAGE

Symbol Glossary

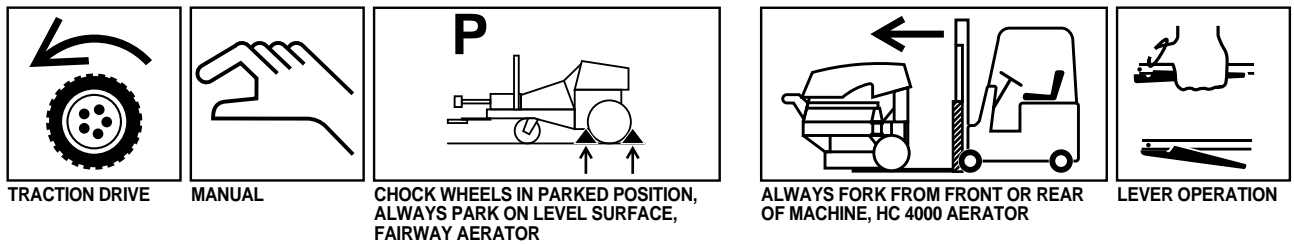
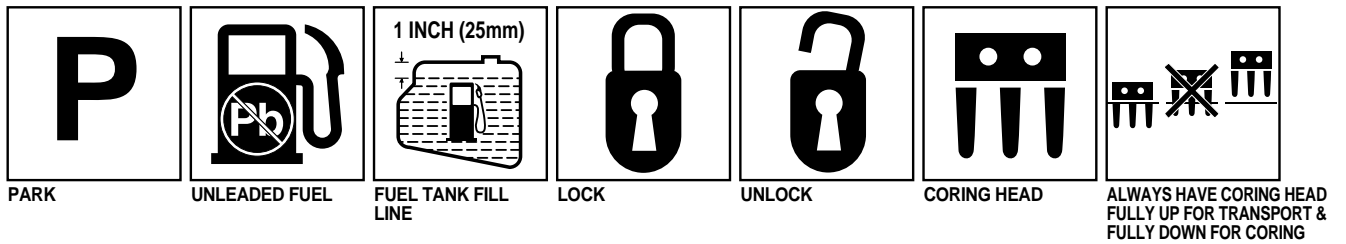
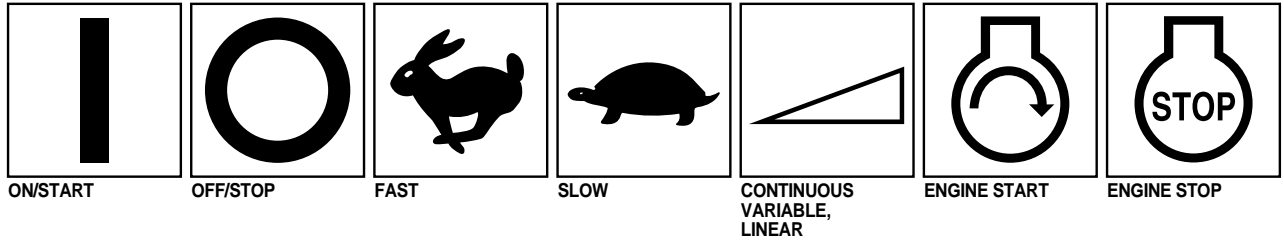

Specifications

Engine: Briggs & Stratton, Vanguard, 4-cycle, air-cooled, 2-cylinder 11.9 kW (16 hp) @ 3600 rpm, 74.4 cm³ (29.3 cu. in) displacement. Electric start. Large capacity dual element air cleaner. Full pressure lubrication 1.55 l (3.5 pint) oil capacity. Solid-state electronic ignition.

Electrical: 12-volt battery, 32-amp-hour. 16-amp alternator. Ignition switch and interlock switches on control handle, transmission and coring head clutch.

Fuel Capacity: 17 l (4.5 gallons) unleaded gasoline.

Traction Drive: Double-banded V-belt from mechanical clutch on engine to Peerless Model 2361 transaxle. Two speeds forward and one reverse. Wheels driven individually by chains from transaxle.

Ground Speed:

1st Gear Forward: 1.8 km/h @ 3600 rpm (coring)

2nd Gear Forward: 5.3 mph @ 3600 rpm (transport)

Reverse: 3.1 km/h @ 1800 rpm.

Ground Clearance: 10.2 cm (4 inches).

Tires/Wheels: Two steering tires (front): 13 X 5.00-6, 2 ply, rib tread tubeless.

Two drive tires (rear): 18 X 9.50-8, 4 ply, Rib Terra tubeless. Drop center demountable rims, greaseable tapered roller bearings.

Recommended tire pressure for front and back tires is 69 kPa (10 psi).

Frame: Welded steel construction—tricycle.

Service Brake: Disc-type mounted to transaxle.

Controls: Traction clutch, coring head hydraulic lift and key switch on control console. Throttle and choke on engine. Transaxle shift lever on frame. Interlock switches and service brake on steering handle.

Implement Drive: Triple banded V-belt from engine to coring head.

Coring Unit Construction: Welded steel frame construction with four crankshafts mounted in precision ball

bearings. Crankshafts drive four coring arms/tine heads.

Drive: No. 50 O-ring sealed roller chain from countershaft to coring crankshafts.

Lift: Single hydraulic cylinder powered by a vane type pump. Control valve actuated by lift control lever.

Tine Heads: 4 individual heads each holding three tines. Deflector chutes direct cores rearward away from drive components.

Coring Width: 27 inches

Hole Pattern: 2.25 inches X 2.5 inches

Coring Depth: Up to 3.5 inches.

Tines: Case hardened tubing, hollow tapered design. 5/8" tines standard. 12 tines required per unit.

Dimensions:

Length:	193 cm (76 inches)
Width:	141 (55.5 inches)
Height:	99.1 cm (39 inches)
Wheelbase:	111.8 cm (44 inches)
Weight:	461.8 kg (1236 pounds)

Optional Accessories:

5/8" Tine	Part No. 59-3670
1/2" Tine	Part No. 94-3419
3/8" Tine	Part No. 59-3690
3/8" Slotted Tine	Part No. 94-3418
5/8" Long Wear Tine	Part No. 59-9770
5/16" Solid Spiker Tine	Part No. 77-5320
*3/4" Tine	Part No. 62-4600
*3/4" Slotted Tine	Part No. 92-7941
*Tine Block	Part No. 62-4610
3/8" Slotted Tine Kit	Part No. 94-6814
1/4" Spiker Tine Kit	Model 09153
Windrower	Model 09150
Coring Head Stand	Model 09152
Tire Scrapers	Model 09151

*3/4" tines requires 8 optional Tine blocks

Before Operating

ACTIVATE AND CHARGE THE BATTERY

1. Since the battery is not filled with electrolyte or activated, bulk electrolyte with 1.260 specific gravity must be purchased from a local battery supply outlet.

CAUTION

Wear safety goggles and rubber gloves when working with electrolyte. Charge the battery in a well-ventilated place so gases produced while charging can dissipate. Since the gases are explosive, keep open flames and electrical spark away from the battery; do not smoke.

Nausea may result if the gases are inhaled. Unplug the charger from the electrical outlet before connecting or disconnecting charger leads.

2. Remove the wing nuts and washers securing the battery clamp to the battery bolts and remove the battery from the machine. Remove the filler caps from the battery and slowly fill each cell until electrolyte is just above the plates (Fig. 1)

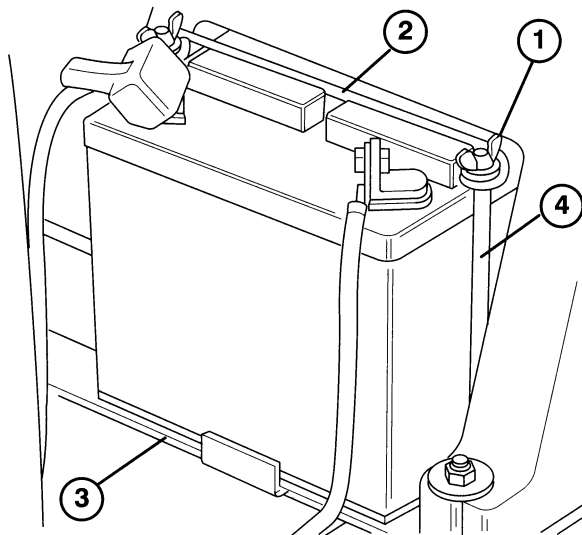

Figure 1

- | | |
|------------------------|-----------------|
| 1. Wing nuts & washers | 3. Battery pad |
| 2. Battery clamp | 4. Support rods |

3. Replace filler caps and connect a 3- to 4-am battery charger to the battery posts. Charge the battery at a rate of 3 to 4 amperes for 4 to 8 hours.
4. When the battery is charged, disconnect the charger from the electrical outlet and battery posts.
5. Remove the filler caps. Slowly add electrolyte to each cell until the level is up to the fill ring. Install the filler caps.
Important: Do not over-fill the battery. Electrolyte will overflow onto other parts of the machine and sever corrosion and deterioration will result.
6. Mount the battery on the battery pad with the terminal posts toward the rear of the machine.
7. Secure the battery with the battery bolts, clam, washers and wing nuts (Fig 2).
8. Install the positive cable (rubber boot over the end) to the positive terminal and the negative cable (black to the negative terminal of the battery and secure with carriage bolts, lockwashers and nuts. Slide the rubber boot over the positive terminal to prevent possible short-out.

CHECK THE CRANKCASE OIL

The engine is shipped with 1.5 l of oil in the crankcase; however, the oil level must be checked before and after the engine is first started.

1. Position the machine on a level surface.
2. Remove the dipstick and wipe it with a clean rag. Push the dipstick down into the dipstick tube and make sure it is seated fully. Pull the dipstick out and check the level of oil (Fig. 2). If the oil level is low, add enough oil to raise the level to the FULL mark on dipstick.

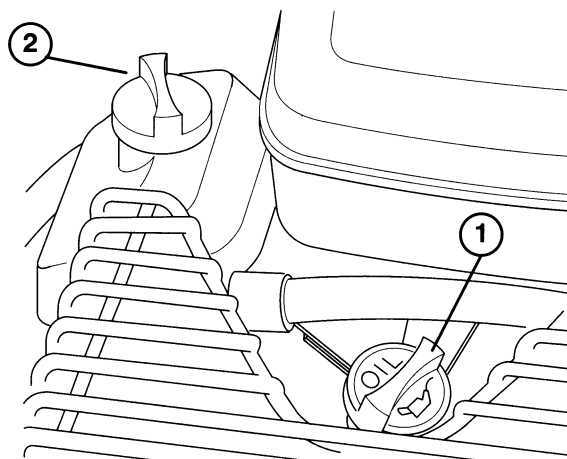

Figure 2

1. Dip stick 2. Filler cap

3. Remove the filler cap and pour oil into the filler neck until the level is at the FULL mark on the dipstick. The engine uses any high-quality oil having the American Petroleum Institute—API- “service classification” SF. Oil viscosity—weight —must be selected according to ambient temperature. Temperature/ viscosity recommendations are:
 - A. Above +32° F (0° C)—Use SAE 30, and if it is not available, 10W-30 or 10W-40 are acceptable substitutes.
 - B. Below +32° F (0° C)—Use SAE 5W-20 or 5W-30, and if they are not available. 10W30 or 10W-40 are acceptable substitutes.

IMPORTANT: Check the oil level every eight (8) operating hours or daily. Initially, change the oil after the first 8 hours of operation; thereafter, under normal conditions, change the oil after each 50 hours of operation and the filter after every 100 hours of operation. However, change the oil more frequently when the engine is operated in extremely dusty or dirty conditions, under heavy load or in high ambient temperatures.

FILL THE FUEL TANK WITH GASOLINE

This engine is certified to operate on unleaded gasoline. Use clean, fresh, unleaded gasoline with a minimum of 85

octane. Do not mix oil with gasoline. Purchase fuel in quantity that can be used within 30 days to assure fuel freshness. Use Briggs & Stratton Gasoline Additive (See your authorized Briggs & Stratton Service Dealer for Part No. 5041 or the single-use pouch.)

In countries other than the U.S.A., leaded gasoline may be used if it is commercially available and unleaded is unavailable.

Note: Some fuels called oxygenated or reformulated gasolines, are gasoline blended with alcohols or ethers. Excessive amounts of these blends can damage the fuel system or cause performance problems. Do not use gasoline which contains Methanol. If any undesirable operating symptoms occur, use gasoline with a lower percentage of alcohol or ether.

1. Remove the cap from the fuel tank (Fig. 2) and fill the 4.5 gallon tank to within 1 inch from the top with unleaded gasoline. Install the fuel tank cap tightly.

DANGER

Because gasoline is flammable, use caution when storing or handling it. Do not fill the fuel tank while the engine is running, hot or when the machine is in an enclosed area. Vapors may build up and be ignited by a spark or flame source many feet away. **DO NOT SMOKE** while filling the fuel tank to prevent the possibility of an explosion. Always fill the fuel tank outside and wipe up any spilled gasoline before starting the engine. Use a funnel or spout to prevent spilling gasoline before starting the engine and fill the tank to about 1 inch (25 mm) below the filler neck. Store gasoline in a clean safety-approved container and keep the cap in place on the container. Keep gasoline in a cool, well-ventilated place; never in an enclosed area such as a hot storage shed. To assure volatility, do not buy more than a 30-day supply of gasoline. Gasoline is a fuel for internal combustion engines; therefore, do not use it for any other purpose. Since many children like the smell of gas, keep it out of their reach because the fumes are explosive and dangerous to inhale.

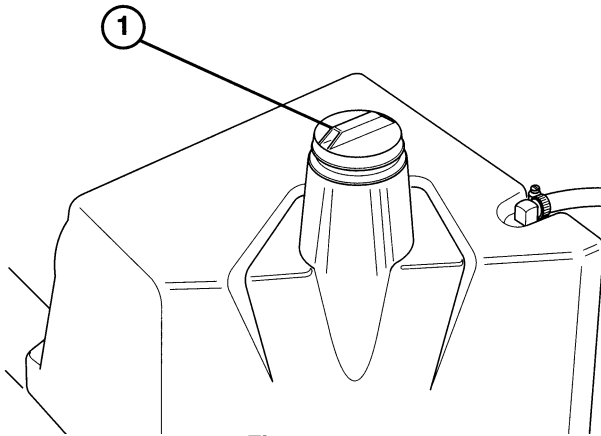

Figure 3

1. Vented fuel tank cap

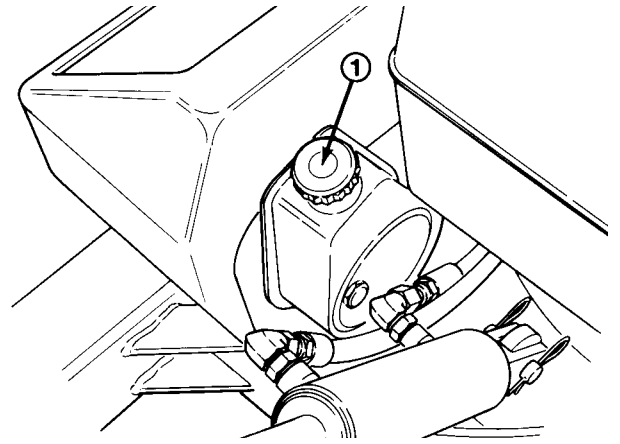

Figure 4

1. Dip stick cap

2. To prevent a fire hazard, wipe up gasoline that may have spilled.

CHECK HYDRAULIC SYSTEM FLUID

The hydraulic system is designed to operate on SAE 10 W-30 engine oil or, as a substitute, SAE 10 W-40 engine oil. The machine's reservoir is filled at the factory with 2.7 pints of SAE 10 W-30 engine oil. However, check the level of hydraulic fluid before the engine is first started and daily thereafter.

1. Position the machine on a level surface and raise the coring head to the full up position.
2. Remove the dipstick cap (Fig. 4) from the filler neck and wipe it with a clean cloth. Insert the dipstick cap into the filler neck; then remove it and check the level of fluid. If the level is not within 1.25 cm ($\frac{1}{2}$ inch) from the full mark on the dipstick, add SAE 10W-30 engine oil to raise the level to full mark. Do not overfill.
3. Install the dipstick filler cap onto the filler neck.
4. Run the engine for one minute, recheck the level of fluid and add oil as needed.

Controls

Ignition Switch (Fig. 5)—The ignition switch, which is used to start and stop the engine, has three positions: OFF, ON and START. Rotate key clockwise—START position—to engage starter motor. Release key when the engine starts. The key will automatically return to the ON position. To shut the engine off, rotate key counter-clockwise to the OFF position.

Choke (Fig. 5)—To start a cold engine, close the carburetor choke by pulling the choke control outward to the ON position. After the engine starts, regulate the choke to keep the engine running smoothly. As soon as possible, open the choke by pushing it inward to the OFF position. A warm engine requires little or no choking.

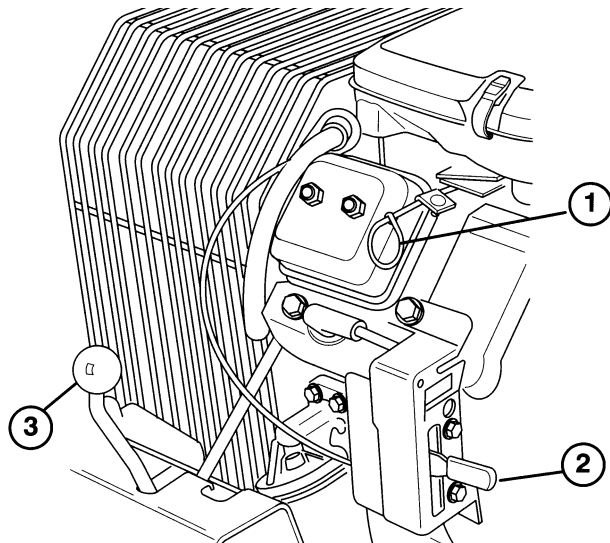

Figure 5

1. Choke
2. Throttle
3. Gear shift lever

Throttle (Fig. 5)—The throttle is used to operate the engine at various speeds. Moving the throttle upward increases engine speed—FAST; rearward decreases engine speed—SLOW. The throttle controls the speed of the coring head and, in conjunction with traction clutch, controls the ground speed of the machine.

Gear Shift Lever (Fig. 5)—The transmission has two forward speeds, neutral and reverse, and has an inline shaft pattern. Do not shift while unit is moving, because transmission damage may occur.

Traction Drive Lever (Fig. 6)—Shift to the desired gear and move the traction drive lever to the engage position to move forward or reverse. One of the hand-operated interlock levers (Fig. 7).

Coring Head Lever (Fig. 6)—Raises and lowers the coring head and engages and disengages the drive.

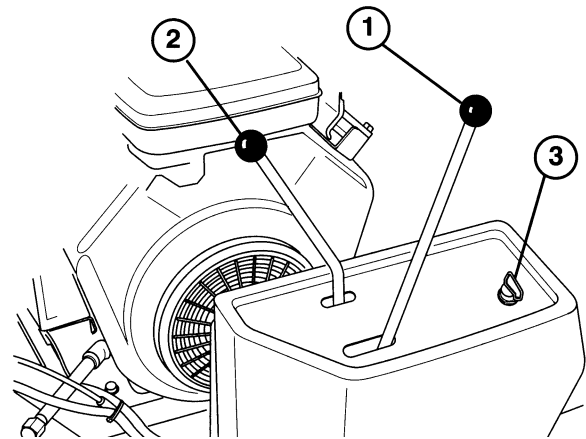

Figure 6

1. Traction drive lever
2. Coring head lever
3. Ignition switch

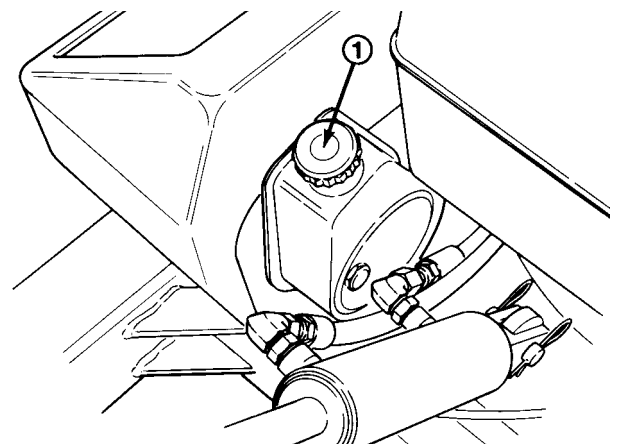

Figure 7

1. Interlock lever switches
2. Service brake

Interlock Lever Switches (2) (Fig. 7)—Switches permit engine operation when the coring head is lowered. They also hold the traction drive lever in the engaged position. One handle switch must be activated before engaging the traction drive or lowering the coring head when engine is running.

Service Brake (Fig. 7)—Used to slow the traction operation.

Operating Instructions

STARTING/STOPPING ENGINE

1. Make sure both wires are installed on the spark plugs.
2. Make sure the traction drive is disengaged and the gear shift lever is in Neutral.
3. Pull the choke lever out to the ON position—when starting a cold engine—and the throttle lever to the mid position.
4. Insert the key into the ignition switch and turn it clockwise to start the engine. Release the key when the engine starts. Gradually return the choke lever to the OFF position (lever all the way in) after the engine starts and warms up.

IMPORTANT: To prevent overheating of the starter motor, do not the starter longer than 10 seconds. After 10 seconds of continuous cranking, wait 60 seconds before engaging the starter again.

5. Make sure the coring head is in the raised position.

Note: When starting the engine for the first time, or after engine, transmission or axle overhaul, operate the machine in forward and reverse for one to two minutes to be sure all parts operate correctly.

6. To stop the engine, move the throttle control downward to the SLOW position and turn the ignition key to “OFF”,

INSTALL THE TINES

1. Start the engine: refer to *Starting/Stopping* instructions.
2. Move the coring head lever to the “UP” position to raise the coring head.
3. Stop the engine and raise the lock-up brackets on each side of the chassis (Fig. 8). Lower the coring head until it rests on brackets.

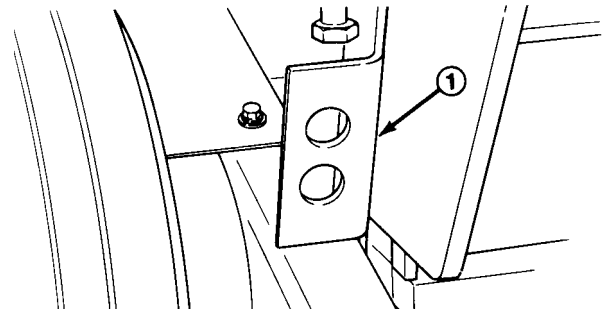

Figure 8

1. Lock-up bracket

4. Loosen (2) hex nuts on each tine block until tines can be inserted. Insert tines until they bottom out on the flange in the tine block (Fig. 8).

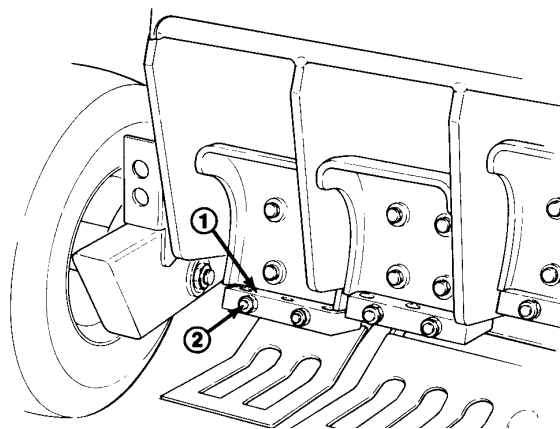

Figure 9

1. Tine block
2. Mounting nut

5. Tighten the mounting nuts to 100-110 ft/lb. torque (Fig. 10).

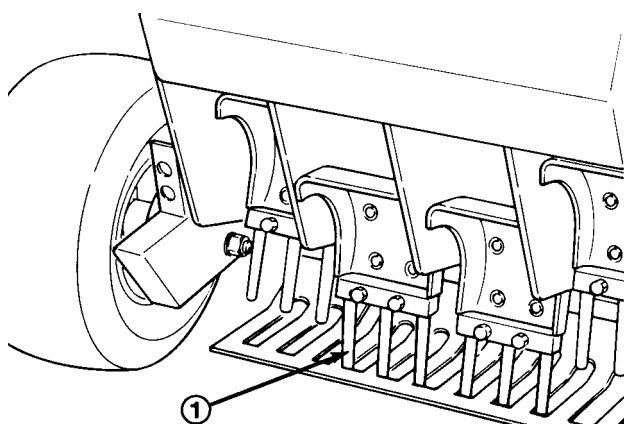

Figure 10

1. Tine

ADJUST THE CORING DEPTH

1. Raise the coring head and engage the lock-up brackets.
2. Loosen the jam nut on top of the adjusting bracket (Fig. 11).
3. Thread the adjusting screw into the bracket to increase coring depth. Thread it out to decrease depth (Fig.11).
4. Repeat this procedure using the long end of the

height gauge on each rear wheel spindle (Fig. 13).

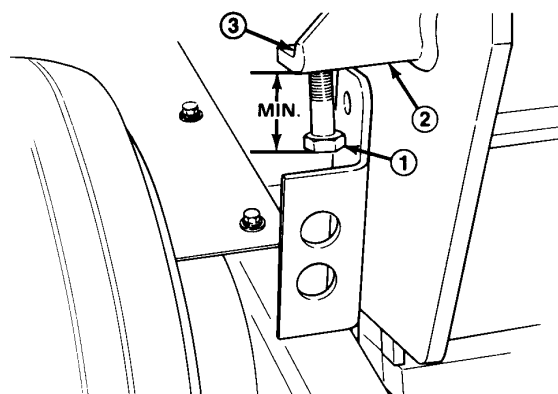

Figure 11

1. Coring depth adjustment screw
2. Adjusting bracket
3. Jam nut

5. Best recommended coring depth is achieved when the distance from the end of the screw head to the bracket is $1\frac{1}{16}$ " (Fig. 11).

IMPORTANT: Do not adjust the screw to a setting less than $1\frac{1}{16}$ " or damage to turf guards may occur.

6. Make sure adjustments are the same on both sides of the coring head and tighten the jam nuts.

CHECK FRAME HEIGHT

1. Position the machine on a level surface.
2. Slide the short end of the frame height gauge under the front axle to verify height. The gauge should contact the axle when on the floor. Check both sides (Fig. 12).

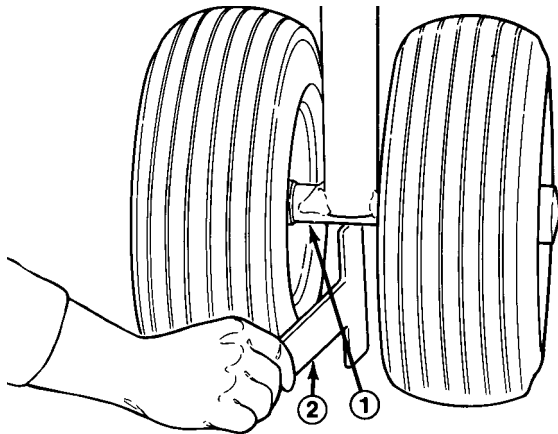

Figure 12

1. Front axle 2. Height gauge

3. Increase or decrease tire pressures to attain the required height.
4. Repeat the procedure using the long end of the height gauge on each rear wheel spindle (Fig. 13).
5. Regulate tire pressure as required.

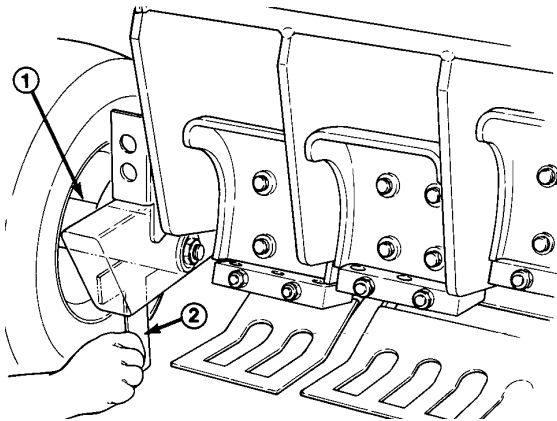

Figure 13

1. Rear wheel spindle
2. Height gauge Regulate tire pressure as required.

OPERATING PROCEDURE

1. Make sure wire is installed on spark plug and fuel valve is open.
2. Start the engine: refer to *Starting/Stopping* instructions.
3. Make sure coring head is in the up position.

4. Squeeze left interlock lever against handle.
5. Move shift lever to “L” (low) for Coring or “H” (high) for Transport.

Note: If you encounter resistance during gear selection, jog the clutch handle until the gears align. Do not shift gears while machine is moving. **DO NOT FORCE SHIFT LEVER AS DAMAGE WILL OCCUR.**

6. Move traction drive lever to engage position.
7. To engage and lower coring head, move coring head lever to down position and hold until coring head is completely lowered.

CHECK INTERLOCK SYSTEM

The safety interlock system’s purpose is to prevent the engine from cranking or starting unless the traction drive lever is disengaged and the coring head is raised. It also interrupts engine operation if a handle-mounted interlock lever is not activated when the coring head is lowered.

To check the interlock system:

1. Position the machine on a flat, open area. Start the engine; refer to *Starting and Stopping* instructions.
2. Check the clutch switch (Fig. 14) with a continuity tester or ohm meter and replace it if damaged. The switch must be closed when the gear shift lever is in a gear. The switch must open when shifting between Neutral, First, and Second gears.
3. To adjust the switch, loosen the mounting screws and reposition the switch as required.
4. If the coring head is in the raised position and the engine will not start, or continues to run when the coring head is down and the interlock lever(s) released, there is a defect in the interlock system, proceed to step 5.
5. Check the coring head switch (Fig. 15) with a continuity tester or ohm meter and replace if damaged. The switch plunger must be depressed when the coring head is in the raised position.

Note: Before coring head switch can be adjusted, coring head drive belt must be correctly adjusted..

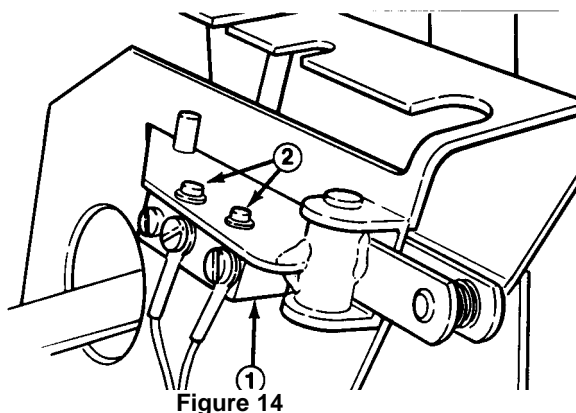

Figure 14

- 1. Traction switch
- 2. Mounting screws

6. If an adjustment to the switch is required, proceed as follows:
 - A. Stop the engine and lower the coring head onto the stand.
 - B. Remove the override pin from the storage bracket on the front of the coring head cover (Fig. 16).
 - C. Push down on the override lever (Fig. 14) until the holes in lever bracket and the coring bracket are aligned, then insert the pin through the holes.
 - D. Loosen the adjusting screw jam nut and (2) flange nuts (Fig. 12).
 - E. Turn the ignition switch to the START position, but do not start the engine.
 - F. While holding the ignition switch in the START position, tighten the adjusting screw until the engine cranks.
 - G. Release the ignition switch and tighten the adjusting screw one more turn.
 - H. Tighten the adjusting screw jam nut and (2) flange nuts.

- I. Restart the engine and raise the coring head.
- J. Stop the engine, remove the override pin and reinstall it in the storage bracket.
- K. Start the engine and check all modes of operation. The coring head should not run when on coring head lock-up brackets.

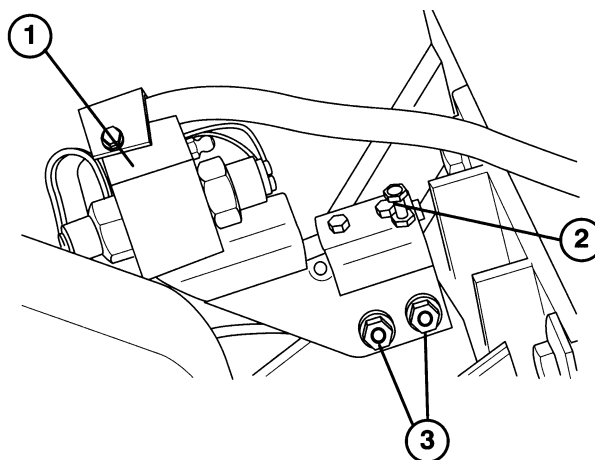

Figure 15

- 1. Coring head switches
- 2. Adjusting screw & jam nut
- 3. Mounting screws

VERRIDE SYSTEM

The coring head is equipped with a release mechanism that allows the engine to be started when the coring head is in the lowered position.

1. Remove override pin from storage bracket on front of coring head cover (Fig. 16).

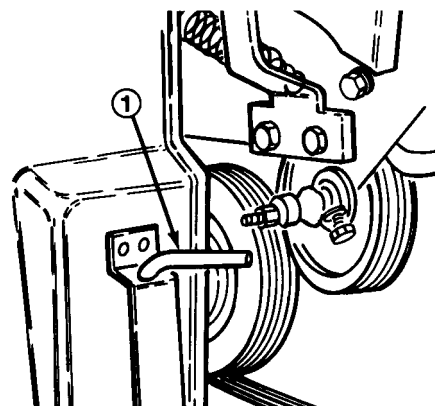

Figure 16

- 1. Override pin

2. Push down on override lever until holes in lever bracket and coring head are aligned, then insert pin through holes (Fig. 17).

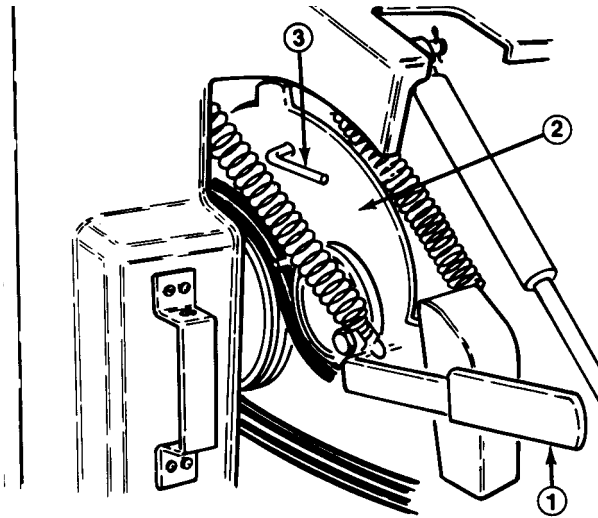

Figure 17

1. Override lever
2. Lever bracket
3. Override pin

3. Restart the engine and raise the coring head.
4. Stop the engine, remove the pin and reinstall in storage bracket.

TRAINING PERIOD

Before aerating greens with the Greens Aerator, find a clear area and practice starting and stopping, raising and lowering coring head, turning, etc. This training period will help the operator gain confidence in the performance of the Greens Aerator.

BEFORE AERATING

Inspect the green for debris and determine the best direction and pattern to operate machine.

AERATING PROCEDURES

1. Approach the green with the gear shift lever in the “L” (low) position.
2. Lower the coring head after you attain the desired starting position. Make sure the coring head is

engaged before the tines are within one inch of the turf.

3. Use the rubber guides hanging from front of chassis to align rows.

CAUTION

Always have the coring head fully raised when transporting and fully lowered when coring so the safety interlock system functions correctly. If the coring head lowers by itself, correct this malfunction before continuing operation.

TRANSPORT OPERATION

Make sure the coring head is in the up position and the coring head lock-up brackets are up. Set the gear shift lever in the “H” (high) position if faster ground speed is required. Use the service brake to slow the machine while going down steep hills to avoid loss of control. Always approach rough areas at a reduced speed and cross severe undulations carefully.

INSPECTION AND CLEAN-UP AFTER USE

At completing operation, thoroughly wash the machine with a garden hose *without a nozzle so excessive water pressure will not cause contamination and damage the seals and bearings*. After cleaning, inspect the machine for possible hydraulic fluid leaks, damage or wear to hydraulic and mechanical components and check the tines for sharpness.

Maintenance

Lubrication

The Greens Aerator has grease fittings that must be lubricated daily with No. 2 General Purpose Lithium Base Grease. Damper pivots must be lubricated every 4 hours of operation.

The bearings and bushings that must be lubricated are: front wheels (Fig. 18), rear wheel spindles (Fig. 19), front handle shaft (Fig. 20), damper pivots (4) (Fig. 21), traction roller latch pin (Fig. 22) speed control lever (Fig 23) and coring head switch (Fig. 24).

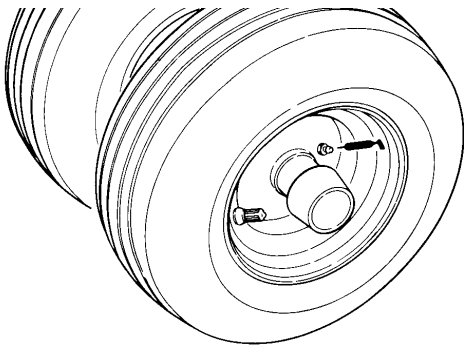

Figure 18

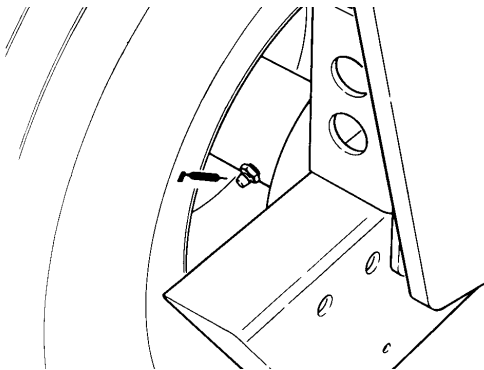

Figure 19

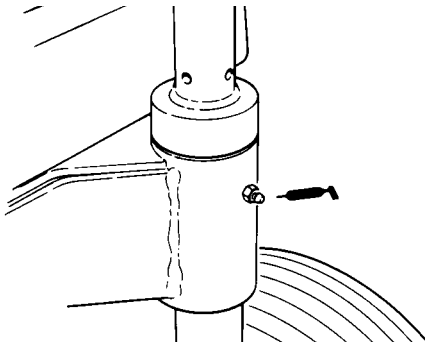

Figure 20

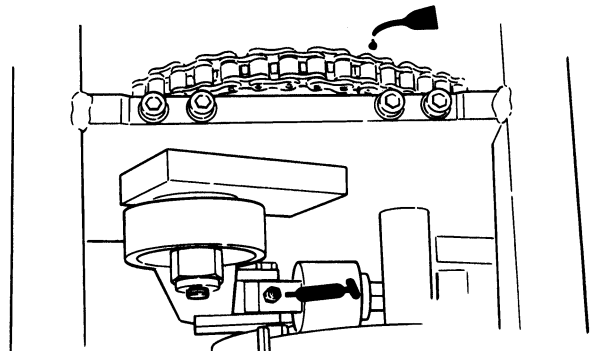

Figure 21

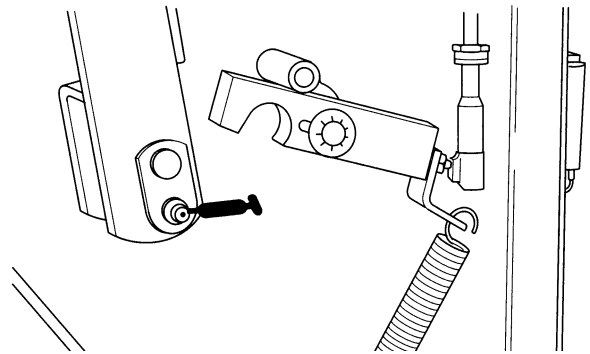

Figure 22

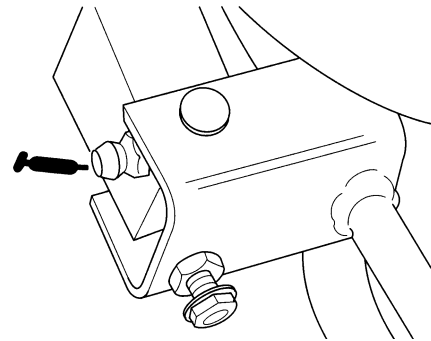

Figure 23

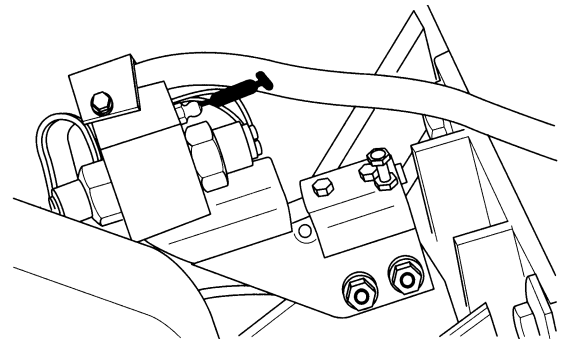

Figure 24

Minimum Recommended Maintenance Intervals

Maintenance Procedure	Maintenance Interval & Service			
Lubricate the Dampener Pivots Check the condition of the tines Check the engine oil level	Every 5hours	Every 25 hours	Every 50 hours	Every 100 hours
Service the Air Filter Pre-Cleaner				
†Change the engine oil Service the air filter cartridge Lubricate the coring head switch assembly				
Change the engine oil filter Service the spark plugs Grease the wheel bearing Grease the steering handle spindle Check the battery fluid level Check the battery cable connections Check the coring head chain tension Check the hydraulic pump belt tension				
†Initial break in at 8 hours				
Replace safety switches Change transaxle gear lubricant Replace the hydraulic oil Adjust the valves and torque the head bolts Decarbon the combustion chamber	Annual Recommendations: Items are recommended every 500 hours or one year, whichever occurs first.			

Check Daily:

- | | |
|--|--|
| <ul style="list-style-type: none"> ✓ Safety interlock operation ✓ Brake operation ✓ Fuel level ✓ Engine oil ✓ Frame height ✓ Air Filter/pre-cleaner condition ✓ Clean the engine cooling fins ✓ Hydraulic system oil level ✓ Unusual operating noises ✓ Tine & stomper arm condition ✓ Hydraulic hoses for damage | <ul style="list-style-type: none"> ✓ Fluid leaks ✓ Tire pressure ✓ Instrument operations ✓ Tighten loose fasteners ✓ Lubricate dampener pivots¹ ✓ Lubricate all grease fittings¹ ✓ Touch-up damaged paint |
|--|--|

¹ = Immediately after every washing, regardless of the interval listed

CAUTION

Before servicing or making adjustments to the machine, stop engine and remove key from the switch.

ENGINE CARE

The Engine Manual supplied with your Greens Aerator provides the maintenance procedures for service of the air cleaner, oil requirements, ignition components, etc.

Note: If the Greens Aerator is to be operated at altitudes of 3000 feet or above sea level, it may require a high altitude carburetor main jet. Order Part No. 8055537 from your Authorized Briggs & Stratton Service Dealer.

CHANGING HYDRAULIC SYSTEM OIL

The hydraulic system oil must be changed immediately when any contamination, sludge, water or condensation appears.

1. Remove the tines from the tine blocks and lower the coring head; refer to *Install Tines*.
2. Position a drain pan under the chassis below the pump assembly (Fig. 25).
3. Remove the hose clamp securing the return hose to the pump. Disconnect the hose from the pump, allowing oil to flow into the drain pan.
4. Connect the return hose to the pump and secure it with the hose clamp.

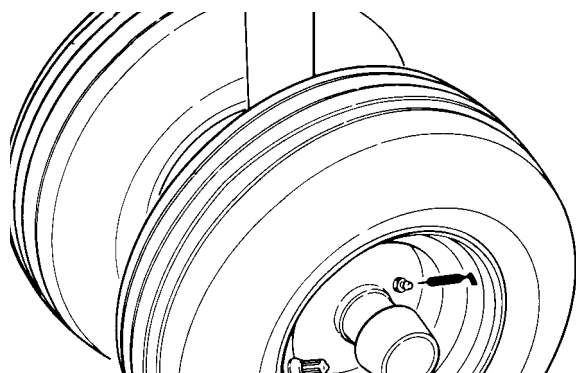

Figure 25

1. Pump reservoir

5. Fill pump reservoir; refer to *Checking Hydraulic System Fluid*.
6. Check all connections for possible leaks.

CHANGING TRANSAXLE OIL

Each year oil in transaxle must be changed. If possible, run the machine just before changing oil. Warm oil flows more freely and carries more contaminants than cold oil.

1. Place a drain pan below the drain plug on the axle. Clean the area around the drain plug (Fig. 26).

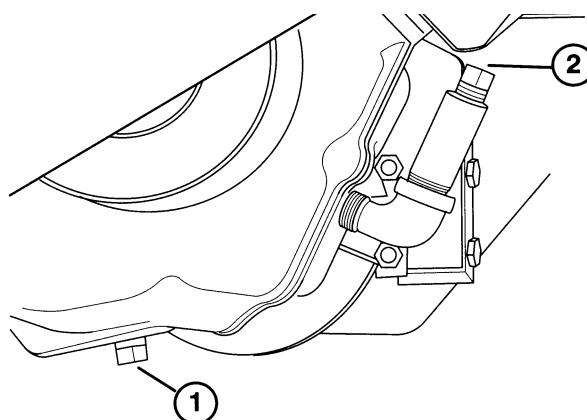

Figure 26

1. Drain plug
2. Fill plug

2. Remove the drain plug and allow oil to flow into the drain pan. After oil is drained, install the drain plug.
3. Remove the fill plug (Fig. 26) and pour approx. 1.89 l (64 oz.) of SAE E.P. 90 wt. oil into the extension tube. Stop when the oil level reaches the top of the tube.
4. To check the oil level in the future: remove the plug and add oil as required to bring the level to the top of the tube.

Hole Quality Trouble Shooting

