



Count on it.

Parts Catalog

**21in Heavy-Duty
Recycler®/Rear Bagger Lawn Mower**

Model No. 22298—Serial No. 40000000 and Up



Ordering Replacement Parts

To order replacement parts, please supply the part number, the quantity, and the description of each part desired.

Understanding Reference Numbers

Each identified part in an illustration has a reference number. The reference number for a part also appears in the parts list, along with other information about the part.

This catalog uses two special reference number formats, one to indicate parts in a service assembly and another to indicate the quantity of a given part in an illustration.

Service Assembly Reference Numbers

Parts in service assemblies have reference numbers in the form a:b. The a represents the reference number of the entire service assembly and the b represents a sequential number unique to each part within the service assembly.

For example, a wheel assembly might be identified by reference number 6, the tire by 6:1, the valve by 6:2, and the wheel by 6:3. When you order the assembly identified by reference number 6, you receive all parts identified by reference numbers 6:1, 6:2, and 6:3. However, you may also order any part individually. Reference numbers of this type appear in illustration and in parts lists.

Reference Numbers Indicating Quantity

In an illustration, if a reference number indicates more than one part, the reference number has the form nX y. The n represents the quantity of the part, the X is the multiplication symbol, and the y represents the reference number.

For example, in an illustration, the reference number 2X 37 means that two of the parts identified by reference number 37 are indicated.

Contents

Housing Assembly	4
Grass Bag Assembly	6
Engine, Fuel-Tank and Blade Assembly	8
Height-of-Cut and Wheel Assembly	10
Transmission and Rear Wheel Assembly	12
Transmission Assembly No. 131-5350	14
Handle and Control Assembly	16
Attachments and Accessories	18

Housing Assembly

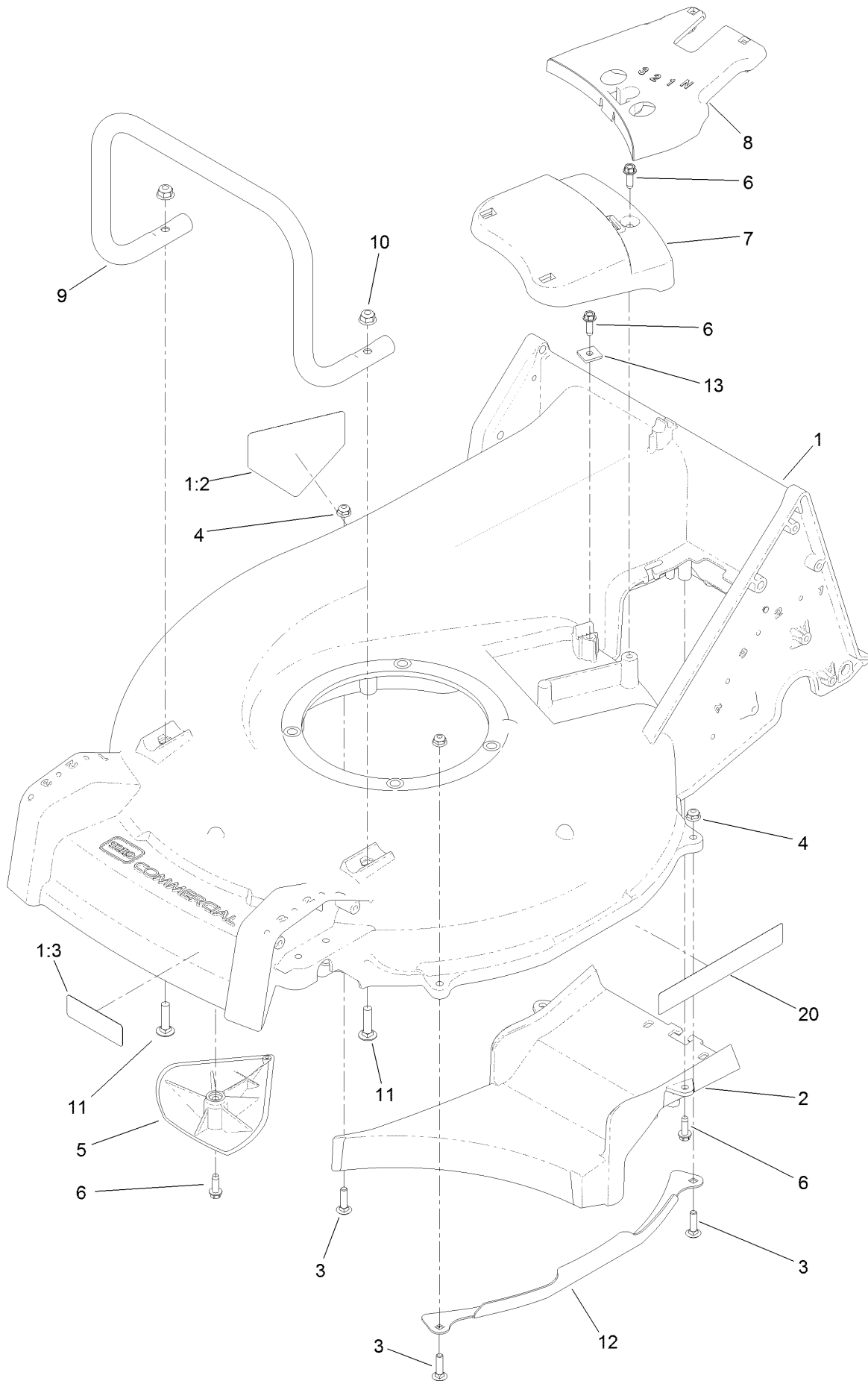

Housing Assembly (continued)

<i>Ref.</i>	<i>Part Number</i>	<i>Qty.</i>	<i>Description</i>	<i>Ref.</i>	<i>Part Number</i>	<i>Qty.</i>	<i>Description</i>
1	136-5896	1	Housing ASM	7	125-5038	1	Cover-Belt, Front
1:2	94-8072	1	Decal-Danger	8	125-5039	1	Cover-Belt, Rear
1:3	130-9670	1	Decal-Warning, Blade	9	125-1003-03	1	Guard-Engine
2	125-1002-01	1	Floor-Chute	10	104-8300	2	Nut-HF, NI
3	3229-2	4	Screw-CARR	11	3230-3	2	Screw-CARR
4	104-7201	4	Nut-HF	12	125-1047-03	2	Guard-Side, Deck
5	125-5041	2	Kicker	13	125-8387	1	Clamp-Cable
6	49-2040	6	Screw-HWHTF	20	119-2368	2	Decal-Recycler

Grass Bag Assembly

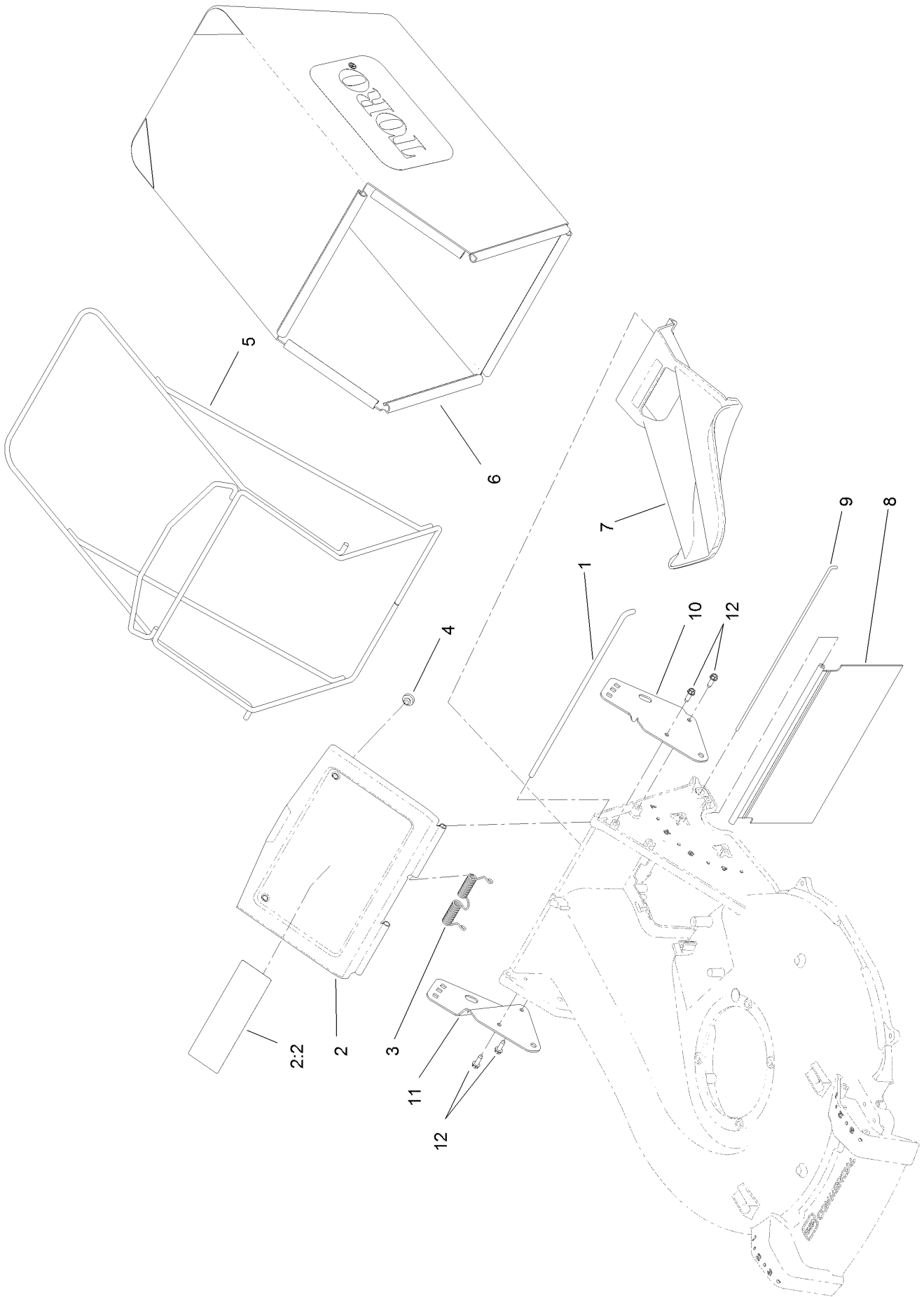

Grass Bag Assembly (continued)

<i>Ref.</i>	<i>Part Number</i>	<i>Qty.</i>	<i>Description</i>	<i>Ref.</i>	<i>Part Number</i>	<i>Qty.</i>	<i>Description</i>
1	125-1017	1	Rod-Door, Bag	7	125-1008	1	Plug-Mulch
2	125-8402	1	Bag Door ASM	8	125-1007	1	Shield-Trailing
2:2	116-7583	1	Decal-Warning	9	125-8413	1	Rod-Shield, Trailing
3	125-1019	1	Spring-Torsion	10	133-8193-03	1	Bracket-Mount, Handle (LH)
4	1-513658	2	Bumper	11	133-8194-03	1	Bracket-Mount, Handle (RH)
5	121-1399-03	1	Frame-Bag	12	32144-70	4	Screw-HWHTF
6	125-1030	1	Bag-Grass				

Engine, Fuel-Tank and Blade Assembly

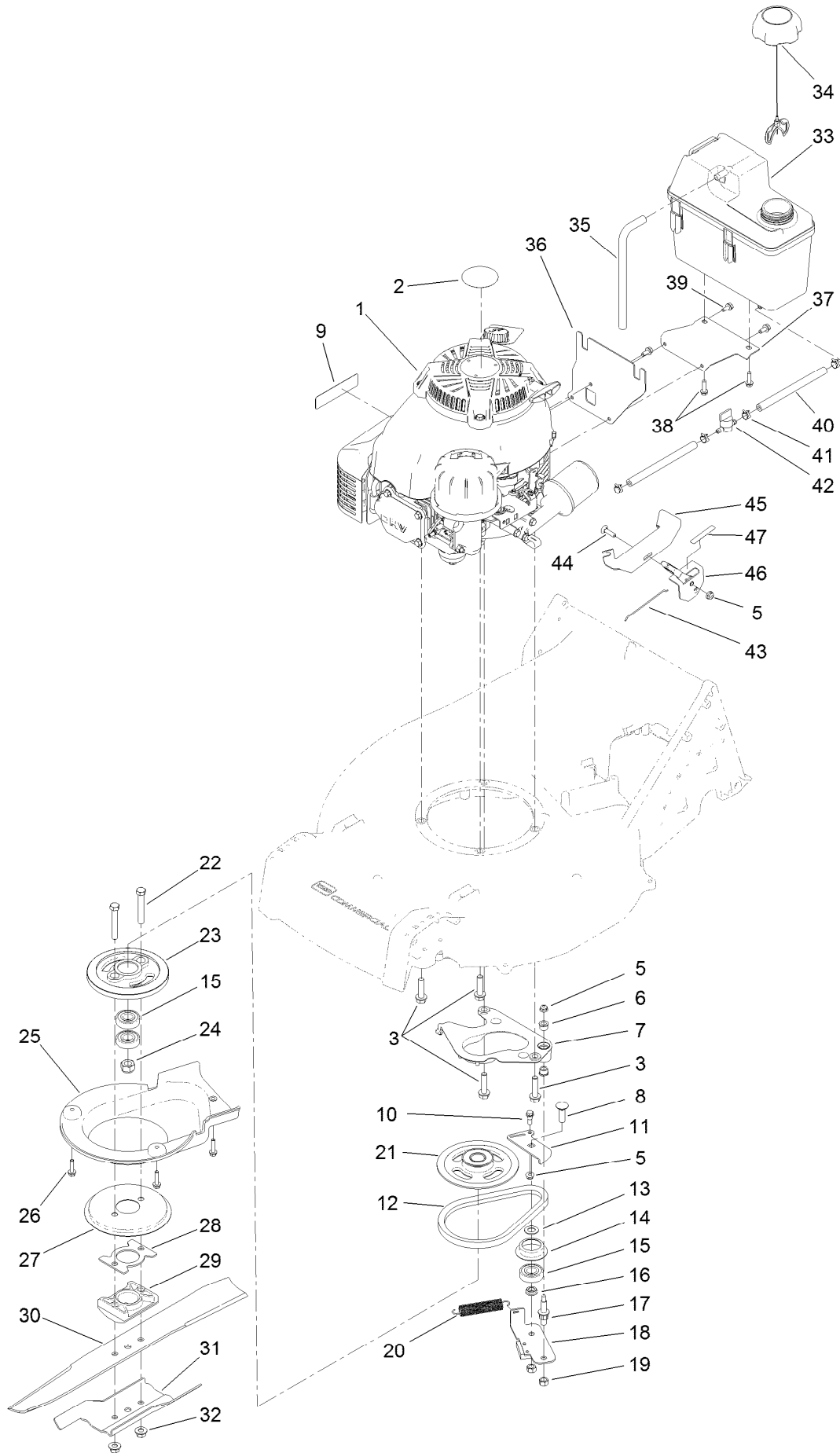

Engine, Fuel-Tank and Blade Assembly (continued)

<i>Ref.</i>	<i>Part Number</i>	<i>Qty.</i>	<i>Description</i>	<i>Ref.</i>	<i>Part Number</i>	<i>Qty.</i>	<i>Description</i>
1	121-1410	1	Engine-Kawasaki, Fj180V	25	125-1006	1	Cover
2	110-0520	1	Decal	26	32144-86	3	Screw-HWHTF
3	125-1073	4	Screw-HWH	27	108-3787	1	Disc
5	104-7201	3	Nut-HF	28	130-6405-03	1	Spacer-Driver, Blade
6	130-2377	2	Bushing-Flange	29	107-7487	1	Support-Blade
7	130-2375	1	Plate-Anchor	30	108-3762-03	1	Blade-Recycling
8	3231-25	1	Bolt-CARR	31	125-1069-03	1	Accelerator-Blade
9	117-2718	1	Decal-Arrester, Spark	32	127-6852	2	Nut-Flange, Lock
10	42-3560	1	Bolt-Shoulder	33	114-0280	1	Tank-Fuel
11	125-8446	1	Plate-Guide, BBC	34	115-7788	1	Cap-Fuel
12	110-1790	1	Belt	35	115-0962	1	Hose-Vent, Canister
13	605256	1	Washer-Plain	36	125-8381-03	1	Bracket-Tank, Mounting
14	108-3790	1	Retainer-Belt	37	125-8382-03	1	Bracket-Tank, Support
15	38-7820	3	Bearing-Ball	38	46-8091	2	Screw-HWH
16	107-0758	1	Spacer-Bearing	39	125-8383	3	Screw-HWH
17	130-9699	1	Bolt-Shoulder	40	107-0588	2	Hose-Fuel
18	125-1063	1	Plate-Brake	41	2412-98	4	Clamp-Hose
19	125-5069	2	Nut-Hex	42	1-603770	1	Valve-Fuel
20	108-3792	1	Spring-Tension, Brake	43	130-9654	1	Wire-Control
21	117-5970	1	Pulley	44	3229-30	1	Screw-CARR
22	3211-42	2	Screw-HH	45	130-6440-03	1	Bracket-Mount, Throttle
23	107-0754	1	Drum	46	130-9655	1	Control-Throttle
24	108-9342	1	Nut-Hex	47	130-9656	1	Decal-Throttle, Choke

Height-of-Cut and Wheel Assembly

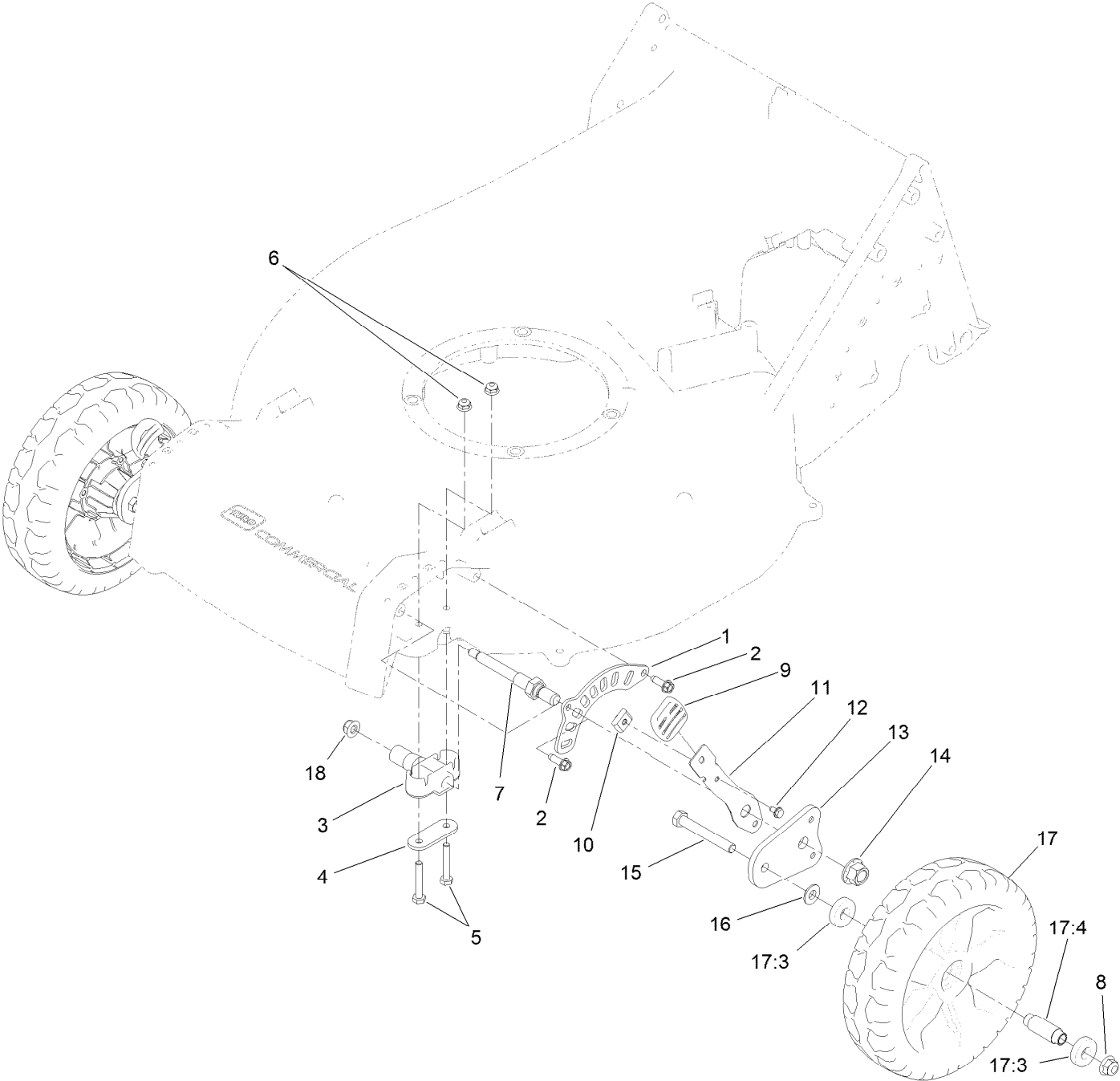

Height-of-Cut and Wheel Assembly (continued)

<i>Ref.</i>	<i>Part Number</i>	<i>Qty.</i>	<i>Description</i>	<i>Ref.</i>	<i>Part Number</i>	<i>Qty.</i>	<i>Description</i>
1	121-1439	2	Plate-HOC, Front	11	121-1431-03	2	Arm-Spring
2	49-2040	4	Screw-HWHTF	12	104-2065	2	Screw-HWH
3	136-5871	2	Bushing-Axle, Front HOC	13	130-6420	2	Arm-Pivot, Front
4	130-6434	2	Retainer-Bushing, Axle	14	99-5107	2	Nut-Lock
5	321-37	4	Screw-HH	15	323-13	2	Screw-HH
6	104-7201	4	Nut-HF	16	74-1671	2	Spacer-Cover, Wheel
7	133-2644	2	Axle-Front HOC	17	125-1080	2	Wheel
8	104-8301	2	Nut-HF, NI	17:3	133-2603	2	Bearing-Ball
9	125-1093	2	Knob-Lever, HOC	17:4	125-1077	1	Spacer
10	131-5377	2	Key-Arm, Spring	18	104-8300	2	Nut-HF, NI

Transmission and Rear Wheel Assembly

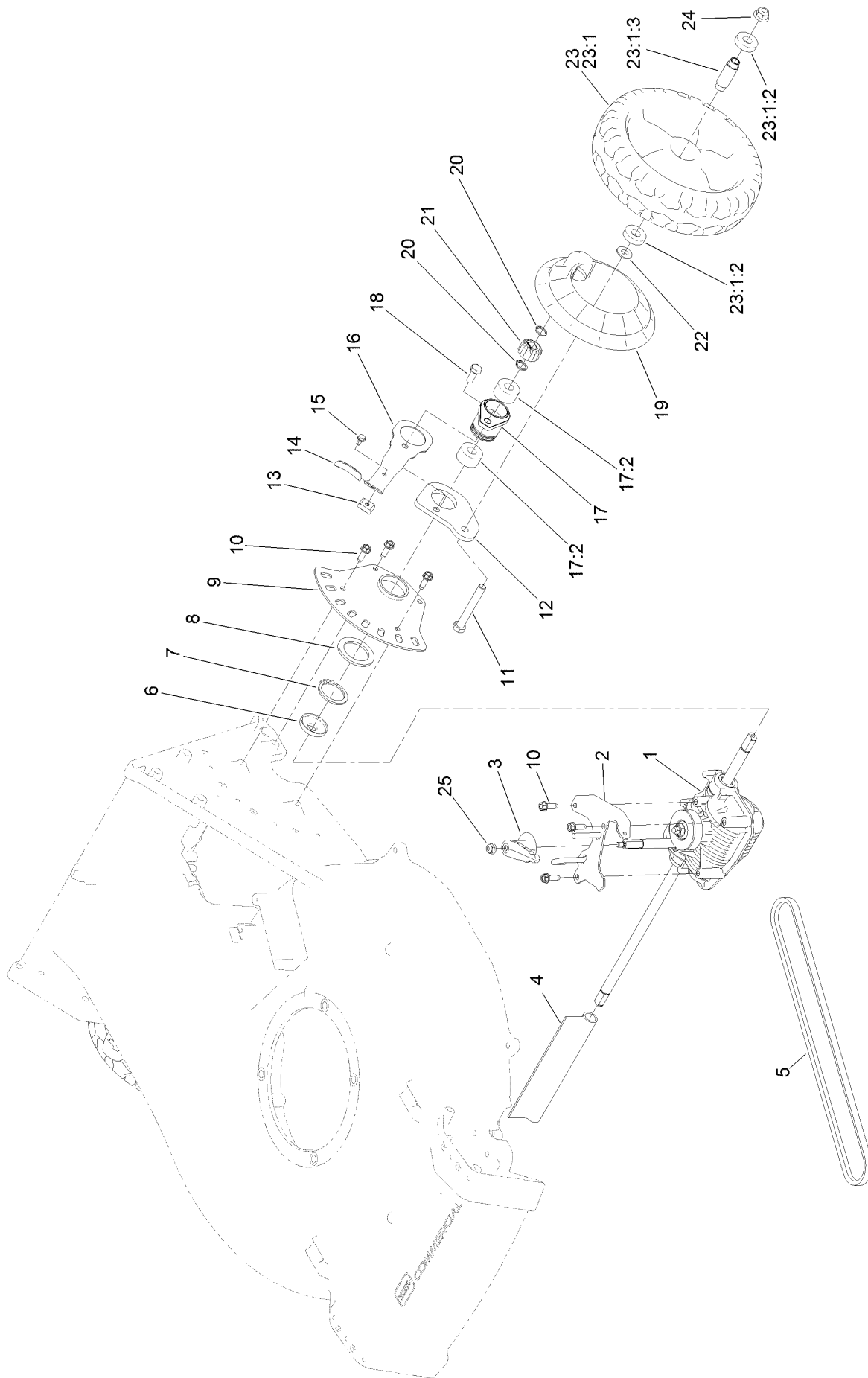

Transmission and Rear Wheel Assembly (continued)

<i>Ref.</i>	<i>Part Number</i>	<i>Qty.</i>	<i>Description</i>	<i>Ref.</i>	<i>Part Number</i>	<i>Qty.</i>	<i>Description</i>
1	131-5350	1	Transmission	16	121-1448-03	2	Arm-Spring, Rear
2	125-5090-03	1	Guide-Belt	17	136-5894	2	Bearing Retainer ASM
3	125-5040	1	Lever-Shift	17:2	133-2606	2	Bearing-Ball, Custom
4	130-9681	1	Cover-Shaft, Transmission	18	133-2668	2	Screw-HH
5	125-1011	1	Belt-V	19	133-2635	2	Cover-Wheel
6	127-6848	2	Cover-Bearing	20	32151-61	4	Ring-Retaining
7	32151-10	2	Ring-Retaining	21	131-5399	2	Gear-Pinion, 15T
8	98-1452	2	Washer-Thrust	22	74-1671	2	Spacer-Cover, Wheel
9	130-6422	2	Plate-HOC, Rear	23	133-2640	2	9-Inch Wheel ASM
10	49-2040	9	Screw-HWHTF	23:1		1	Wheel ●
11	323-13	2	Screw-HH	23:1:2	133-2603	2	Bearing-Ball
12	133-2641	2	Arm-Pivot, Rear	23:1:3	125-1077	1	Spacer
13	131-5377	2	Key-Arm, Spring	24	104-8301	2	Nut-HF, NI
14	125-1093	2	Knob-Lever, HOC	25	104-7201	1	Nut-HF
15	104-2065	2	Screw-HWH				

● Not serviced separately

Transmission Assembly No. 131-5350

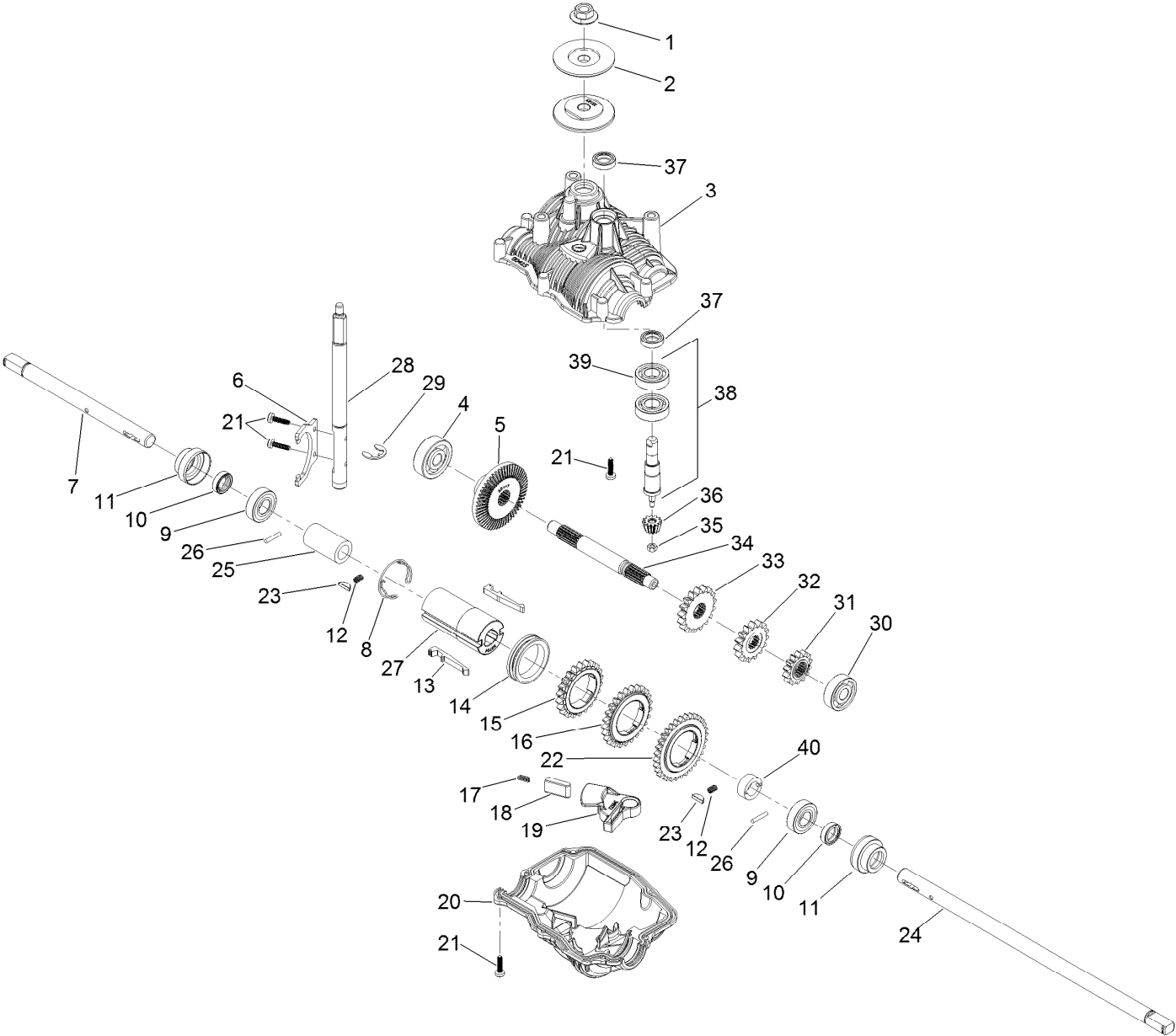

Transmission Assembly No. 131-5350 (continued)

<i>Ref.</i>	<i>Part Number</i>	<i>Qty.</i>	<i>Description</i>	<i>Ref.</i>	<i>Part Number</i>	<i>Qty.</i>	<i>Description</i>
1	130-2301	1	Nut-Flange	21	130-2302	10	Screw
2	130-2326	2	Flange-Pulley	22	130-2317	1	Gear-Output, 32 Tooth
3	130-2336	1	Case-Upper, Transmission	23	133-2614	2	Key
4	130-2318	1	Bearing-Ball	24	133-2612	1	Shaft-Output, Long
5	130-2311	1	Gear-Bevel, 53 Tooth	25	133-2617	1	Spacer-Long
6	130-2327	1	Fork-Shift	26	133-2616	2	Pin
7	133-2611	1	Shaft-Output, Short	27	133-2613	1	Hub-Gear, Output
8	130-2322	1	Spring-Retaining	28	130-2306	1	Shaft-Shift
9	130-9708	2	Bearing-Ball	29	130-2304	1	Ring-Retaining
10	130-2325	2	Seal	30	130-2319	1	Bearing-Ball
11	130-2333	2	Bushing-Shaft, Output	31	130-2314	1	Gear-Intermediate, 14 Tooth
12	133-2615	2	Spring	32	130-2313	1	Gear-Intermediate, 15 Tooth
13	130-2328	2	Key-Shift	33	130-2312	1	Gear-Intermediate, 17 Tooth
14	130-2329	1	Ring-Shift	34	130-2307	1	Shaft-Intermediate
15	130-2315	1	Gear-Output, 22 Tooth	35	130-2303	1	Nut-Shaft, Input
16	130-2316	1	Gear-Output, 25 Tooth	36	130-2310	1	Gear-Bevel, 12 Tooth
17	130-2321	1	Spring-Indexing, Shifter	37	130-2324	2	Seal
18	130-2332	1	Pin-Indexing, Shifter	38	130-2300	1	Shaft-Input
19	130-2331	1	Lever-Indexing, Shifter	39	130-9708	2	Bearing-Ball
20	130-2337	1	Case-Lower, Transmission	40	133-2618	1	Spacer-Short

Handle and Control Assembly

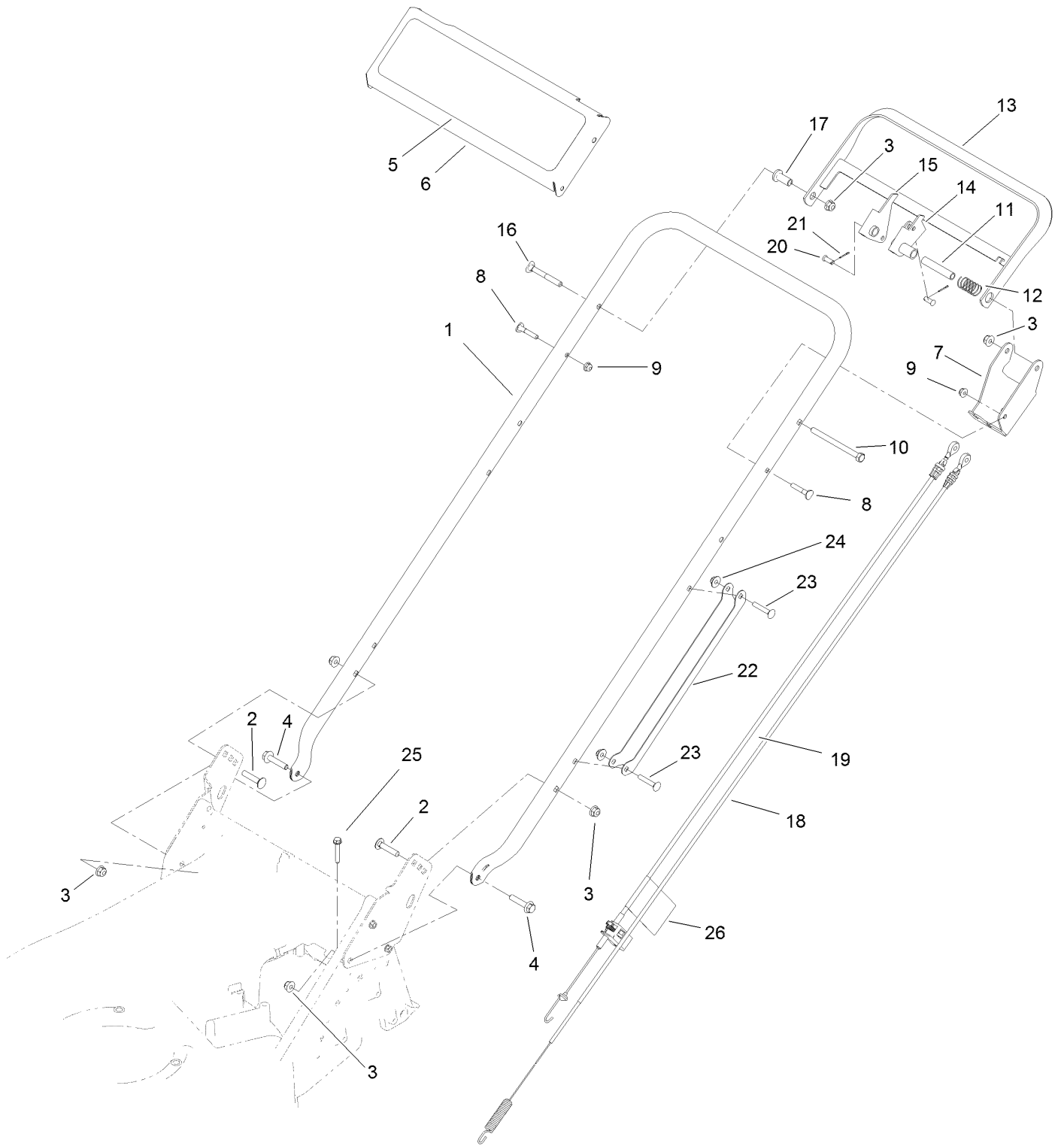

Handle and Control Assembly (continued)

<i>Ref.</i>	<i>Part Number</i>	<i>Qty.</i>	<i>Description</i>	<i>Ref.</i>	<i>Part Number</i>	<i>Qty.</i>	<i>Description</i>
1	125-1016-03	1	Handle	15	125-8354	1	Lever-Traction
2	3230-4	2	Bolt-CARR	16	125-8408	1	Screw-Handle
3	104-8300	6	Nut-HF, NI	17	125-8359	1	Spacer-Flange
4	115-1794	2	Screw-HHF	18	130-9702	1	Cable-BBC
5	125-8421	1	Decal-Toro, Commercial	19	130-9703	1	Cable-Traction, BBC
6	125-8350-01	1	Panel-Control	20	84-9040	2	Pin-Cable
7	125-8358-03	1	Bracket-Control	21	3272-1	2	Pin-Cotter
8	117-7737	2	Screw-Handle	22	127-6897-03	1	Guard-Cable, Handle
9	104-7201	2	Nut-HF	23	108-0988	2	Screw-CARR
10	322-19	1	Screw-HH	24	114-3778	2	Nut-Hex Flg
11	125-8424	1	Spacer	25	94-2691	1	Screw-HWH
12	85-6750	1	Spring-Control	26	130-6722	1	Decal-Adjust, Self Propel Drive
13	125-8357-03	1	Bar-Control				
14	125-8352	1	Lever-Control				

Attachments and Accessories

For 22298 21in Heavy-Duty Recycler/Rear Bagger Lawn Mower

Product Name	Model/Part
Blade-Bagging, 21 Inch	125-1072-03
Cup-Anti Scalp.....	125-8440
Rear Discharge Kit.....	130-9734

Notes:



Count on it.