



MODEL NO. 03502—50001 & UP
MODEL NO. 03504—50001 & UP
MODEL NO. 03530—50001 & UP
MODEL NO. 03531—50001 & UP

**OPERATOR'S
MANUAL**

REELMASTER® 5100-D, 5300-D

To understand this product, and for safety and optimum performance, read this manual before starting the engine. Pay special attention to **SAFETY INSTRUCTIONS** highlighted by this symbol.



It means **CAUTION**, **WARNING** or **DANGER**—personal safety instruction. Failure to comply with the instruction may result in personal injury.

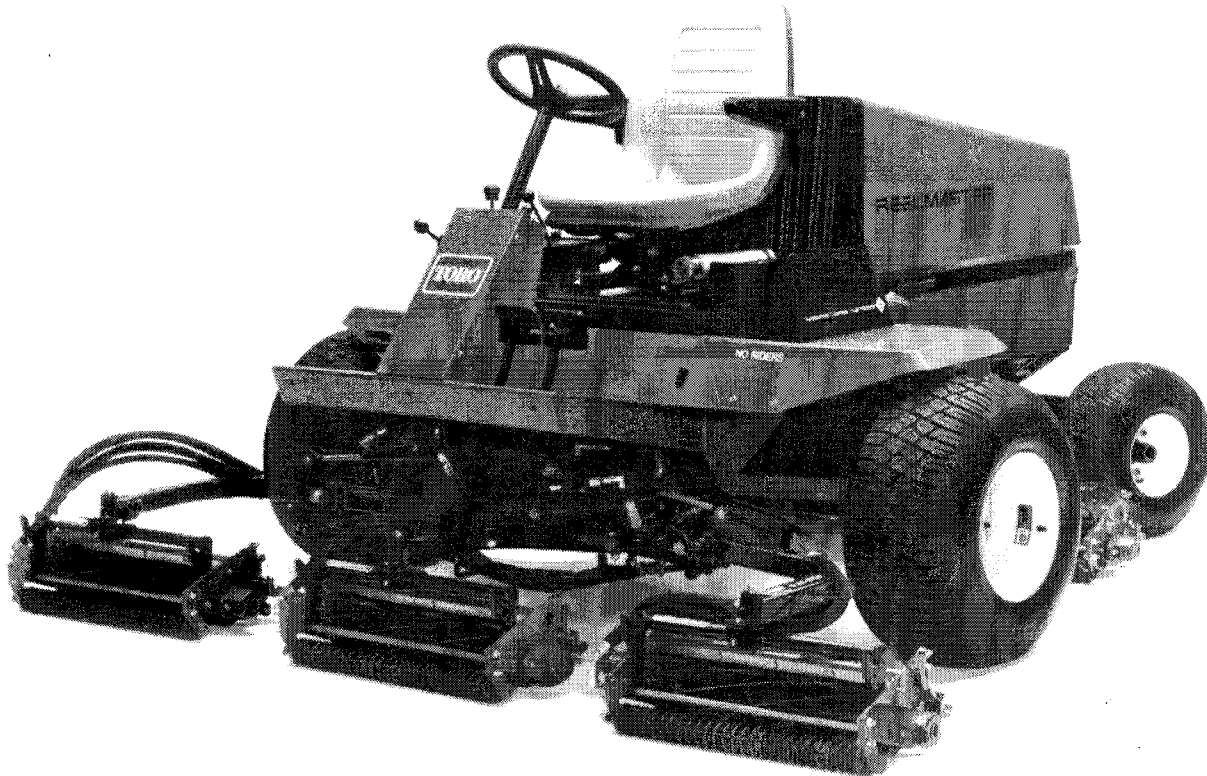

This operator's manual has instructions on safety, operation, and maintenance.

This manual emphasizes safety, mechanical and general product information. DANGER, WARNING and CAUTION identify safety messages. Whenever the triangular safety alert symbol appears, understand the safety message that follows. "IMPORTANT" highlights special mechanical information and "NOTE" emphasizes general product information worthy of special attention.

IDENTIFICATION AND ORDERING

MODEL AND SERIAL NUMBER

The model and serial number for the traction unit is on a plate that is mounted on the left front frame member. The model and serial number for the cutting unit is on a plate that is mounted on the top front of the center cutting unit. Use model and serial number in all correspondence and when ordering parts.

To order replacement parts from an authorized TORO Distributor, supply the following information:

1. Model and serial numbers of the machine.
2. Part number, description and quantity of parts desired.

NOTE: Do not order by reference number if a parts catalog is being used; use the part number.

Table of Contents

	Page
Safety	3
Specifications	9
Before Operating	10
Controls	13
First-Time Operation	16
Operating	20
Maintenance	22

Safety

Training

1. Read the instructions carefully. Be familiar with the controls and the proper use of the equipment.
2. Never allow children or people unfamiliar with these instructions to use the lawn mower. Local regulations may restrict the age of the operator.
3. Never mow while people, especially children, or pets are nearby.
4. Keep in mind that the operator or user is responsible for accidents or hazards occurring to other people or their property.
5. Do not carry passengers.
6. All drivers should seek and obtain professional and practical instruction. Such instruction should emphasize:
 - the need for care and concentration when working with ride-on machines;
 - control of a ride-on machine sliding on a slope will not be regained by the application of the brake. The main reasons for loss of control are:
 - insufficient wheel grip;
 - being driven too fast;
 - inadequate braking;
 - the type of machine is unsuitable for its task;
 - lack of awareness of the effects of ground conditions, especially slopes;
 - incorrect hitching and load distribution.

Preparation

1. While mowing, always wear substantial footwear and long trousers. Do not operate the equipment when barefoot or wearing open sandals.

2. Thoroughly inspect the area where the equipment is to be used and remove all objects which may be thrown by the machine.
3. **WARNING—Petrol is highly flammable.**
 - Store fuel in containers specifically designed for this purpose.
 - Refuel outdoors only and do not smoke while refueling.
 - Add fuel before starting the engine. Never remove the cap of the fuel tank or add petrol while the engine is running or when the engine is hot.
 - If petrol is spilled, do not attempt to start the engine but move the machine away from the area of spillage and avoid creating any source of ignition until petrol vapors have dissipated.
 - Replace all fuel tanks and container caps securely.
4. Replace faulty silencers.

Operation

1. Do not operate the engine in a confined space where dangerous carbon monoxide fumes can collect.
2. Mow only in daylight or in good artificial light.
3. Before attempting to start the engine, disengage all blade attachment clutches and shift into neutral.
4. Do not use on slopes of more than:
 - Never mow side hills over 5°
 - Never mow uphill over 10°
 - Never mow downhill over 15°
5. Remember there is no such thing as a “safe” slope. Travel on grass slopes requires particular

care. To guard against overturning:

- do not stop or start suddenly when going up or downhill;
 - engage the clutch slowly, and always keep the machine in gear, especially when travelling downhill;
 - machine speeds should be kept low on slopes and during tight turns;
 - stay alert for bumps and hollows and other hidden hazards;
 - never mow across the face of the slope, unless the lawn mower is designed for this purpose.
6. Use care when pulling loads or using heavy equipment.
 - Use only approved drawbar hitch points.
 - Limit loads to those you can safely control.
 - Do not turn sharply. Use care when reversing.
 - Use counterweight(s) or wheel weights when suggested in the instruction handbook.
 7. Watch out for traffic when crossing or near roadways.
 8. Stop the blades rotating before crossing surfaces other than grass.
 9. When using any attachments, never direct discharge of material toward bystanders nor allow anyone near the machine while in operation .
 10. Never operate the lawn mower with defective guards, shields or without safety protective devices in place.
 11. Do not change the engine governor settings or overspeed the engine. Operating the engine at excessive speeds may increase the hazard of personal injury.
 12. Before leaving the operator's position:
 - disengage the power take-off and lower the attachments;
 - change into neutral and set the parking brake;
 - stop the engine and remove the key.
 13. Disengage the drive to attachments when transporting or not in use.
 14. Stop the engine and disengage the drive to the attachment
 - before refueling;
 - before removing the grass catcher;
 - before making height adjustments unless the adjustment can be made from the operator's position.
 - before clearing blockages;
 - before checking, cleaning or working on the lawnmower;
 - after striking a foreign object. Inspect the lawnmower for damage and make repairs before restarting and operating the equipment.
 15. Reduce the throttle setting during engine runout and, if the engine is provided with a shutoff valve, turn the fuel off at the conclusion of mowing.

Maintenance and Storage

1. Keep all nuts, bolts and screws tight to be sure the equipment is in safe working condition.
2. Never store the equipment with petrol in the tank inside a building where fumes may reach an open flame or spark.
3. Allow the engine to cool before storing in any enclosure.
4. To reduce the fire hazard, keep the engine, silencer, battery compartment and petrol storage area free of grass, leaves, or excessive grease.
5. Check the grass catcher frequently for wear or deterioration.
6. Replace worn or damaged parts for safety.

7. If the fuel tank has to be drained, this should be done outdoors.
8. Be careful during adjustment of the machine to prevent entrapment of the fingers between moving blades and fixed parts of the machine.
9. On multi-bladed machines, take care as rotating one blade can cause other blades to rotate.
10. When the machine is to be parked, stored or left unattended, lower the cutting means unless a positive mechanical lock is used.

Symbol Glossary

Safety alert symbol



Dismemberment—Mower in rearward position.



Safety alert symbol



Stay a safe distance from the machine.

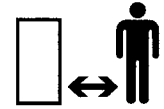

Read operator's manual



Stay a safe distance from the mower.

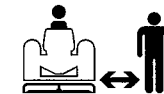

Consult technical manual for proper service procedures



Keep children a safe distance from the machine.

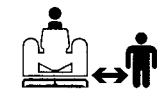

Thrown or flying objects—whole body exposure



Machine rollover—side hill



Thrown or flying objects—rotary side-mounted mower. Keep deflector shield in place.



Machine rollover—up hill



Severing toes or foot—mower blade



Machine rollover—down hill



Severing fingers or hand—mower blade



Machine rollover—roll over protection system





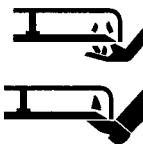



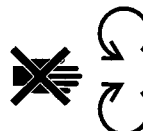



















Rotating blade can cut off toes or fingers. Stay clear of blade as long as the engine is running.



Do not open or remove safety shields while the engine is running.



Fast	
Slow	
Decreasing/increasing	
On/Run	
Off/Stop	
Engine	
Engine start	
Engine stop	
Choke	
Engine temperature	
Engine lubricating oil pressure	
Engine lubricating oil pressure	

Fuel	
Fuel level	
Volume empty	
Volume full	
Battery charging condition	
Head lights—Main/high beam	
Brake system	
Parking brake	
Clutch	
PTO (Power Take Off)	
Engage	
Disengage	
Unlock	
Lock	

Cutting element—basic symbol		Riding on this machine is allowed only on a passenger seat and only if the driver's view is not hindered.	
Cutting element—height adjustment		Crushing of fingers or hands—force applied from the side	
Cutting unit—lower		Kickback or upward motion—stored energy	
Cutting unit—raised		Shut off engine and remove key before performing maintenance or repair work.	
Cutting or entanglement of foot—rotating auger		Machine travel direction—combined	
Severing of fingers or hand—impeller blade		Low	L
Keep a safe distance from snowthrower.		High	
Stay a safe distance from snowthrower.		Reverse	R
Tractors must be equipped with 45 kg rear wheel wheel weight with this attachment installed.		Neutral	
Machine rollover protection system snowthrower		First gear	1
Severing of hand—rotating knives		Second gear	
Severing of foot—rotating knives		Third gear up to a maximum number of forward gears.	3

Specifications

Engine: Mitsubishi three-cylinder, liquid-cooled diesel.

5100-D: 17.2 kW (23 hp) @ governed maximum rpm of 3200; 952 cc (58.1 cu. in.) displacement.

5300-D: 20.9 kW (28 hp) @ governed maximum rpm of 3200; 1,318 cc (80.4 cu. in.) displacement

Heavy duty, 3-stage, remote-mounted air cleaner.
High water temperature shutdown switch.

Cooling System: Radiator capacity is 7.1 l (7.5 qt.) of 50/50 mixture of ethylene glycol anti-freeze. Remote mounted .9 l (1 qt.) expansion tank. A two-speed fan drive controls air flow.

Fuel System: Fuel tank capacity is 37.9 l (10 gal.) of #2 diesel fuel. 12-volt, electric fuel pump with replaceable fuel filter. Equipped with a fuel filter/water separator to capture water in the fuel.

Traction System: Foot pedal controls forward/reverse ground speed. Ground speed: 0–16.1 kmh (0–10 m.p.h.) forward and 0–6.4 kmh (0-4 mph) reverse. Hydrostatic transmission mounted directly on a 20.9:1 ratio front axle. Axle/reservoir capacity is 4.7 l (5 qts). Replaceable filter mounted directly on transmission housing. Models 03501, 03531 only: Mechanical rear axle is coupled to the front axle by a drive shaft and overrunning clutch.

Cutting Unit Drive System: Hydraulic reel motors feature quick disconnects to ease removal/installation on cutting units. Hydraulic fluid reservoir capacity is 32.2 l (8.5 gal.). System protected by a filter assembly with service indicator.

Seat: Deluxe high back seat with adjustable fore and aft travel, weight and height. Tool box at the left side of the seat.

Steering System: Power steering with dedicated power source.

Tires: Two rear tires: 19 x 8.508, tubeless, 4-ply rat-

ing. Two front tires: 26 x 12.0012 tubeless, 4-ply rating. Recommended tire pressure for the front and rear tires is 69–103 kPa (10–15 psi).

Brakes: Individual drum-type wheel brakes on the front traction wheels. Brakes controlled by individual pedals operated by the left foot. Hydrostatic braking through traction drive.

Electrical System: Automotive type electrical system. 12-volt, maintenance free battery with 530 cold cranking Amps @ –18°C (0° F) and 85 minute reserve capacity @ 29° C (85° F). 40-amp alternator with I.C. regulator/rectifier. Seat switch, reel and traction interlock switches. An electronic controller monitors and controls safety and operational functions.

Controls: Foot-operated traction and brake pedals. Hand-operated throttle, traction speed control lever, parking brake lock, ignition switch with automatic pre-heat cycle, single joy stick control for cutting unit on/off and lift/lower. Cutting unit backlap switch and reel speed controls located under the operator seat.

Gauges: Hour meter, speedometer, fuel gauge, temperature gauge. 4 warning lamps: oil pressure, water temperature, amps and glow plug.

General Specifications (approx.):

Width-of-Cut :	241 cm (95 in.)
Overall Width:	
Transport	220 cm (87 in.)
Outside of tires	208 cm (82 in.)
Overall Length:	
Without grass baskets:	263 cm (103.5 in.)
With grass baskets:	294 cm (116 in.)
Height:	
With Rollover protector:	214 cm (84.5 in.)
Without	142 cm (56 in.)
Recommended Height-of-Cut:	
5-Blade Cutting Unit:	1–1.9cm (1/2–3/4 in.)
8-Blade Cutting Unit:	0.4–1.6 cm (1/4–5/8 in.)

Specifications

Weight: Model 03502	821 kg (2,200 lbs.)*
Model 03504	952 kg (2,550 lbs.)*
Model 03530	868 kg (2,325 lbs.)*
Model 03531	998 kg (2,675 lbs.)*

**With 8-Blade Cutting Units, baskets & full fluid levels*

Optional Equipment

5-Blade Cutting Unit, Model No. 03505

8-Blade Cutting Unit, Model No. 03508

Grass Basket Kit, Model No. 03513

Rear Weight Kit, Part No. 75-6690

Rear Roller Scraper Kit, Model No. 03512

Front Roller Scraper Kit, Model No. 83-5400

High Height-of-Cut Kit, Model No. 83-5300

Scraper/Comb Kit, Model No. 03518

Armrest Kit, Model No. 30707

Front Scraper, HHOC Kit P/N 82-6920

Thatcher Unit, Model No. 03516

Precleaner Bowl Extension Tube, Part No. 43-3810
(Clamp, Part No. 20-4840 required to install extension tube)

4-Wheel Drive Kit, Model No. 03517 (For use with models 03502, 03530 only)

Before Operating

CHECK THE ENGINE OIL

1. Park the machine on a level surface. Open the hood.
2. Remove the dipstick, wipe it clean, then reinstall it. Remove it again and check the oil level on the dipstick; The oil level should be up to the FULL mark.

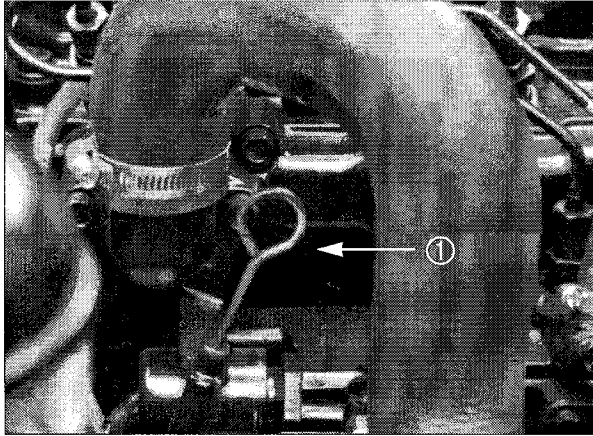

1. Dipstick

3. If the oil is below the FULL mark, remove the fill cap and add SAE 10W-30 CD classification oil until the level reaches the FULL mark on the dipstick. **DO NOT OVERFILL.** Crankcase capacity is 9.1 l with filter.

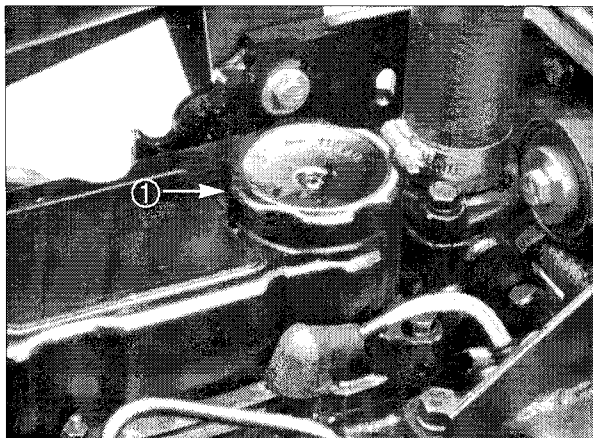

1. Oil Fill Cap

4. Install the oil fill cap and close the hood.

CHECK THE COOLING SYSTEM

Clean debris from the screen, oil cooler and the front of the radiator daily, more often if conditions are extremely dusty and dirty.

The cooling system is filled with a 50/50 solution of water and permanent ethylene glycol anti-freeze. Check the level of coolant in the expansion tank each day before starting the engine. Cooling system capacity is 5.7 l (6 quarts).

CAUTION

If the engine has been running, pressurized hot coolant can escape when the radiator cap is removed and cause burns.

1. Check the level of coolant in the expansion tank. It should be between the marks on the side of the tank.



1. Expansion Tank

2. If coolant level is low, remove the expansion tank cap and replenish the system. **DO NOT OVERFILL.**
3. Install the expansion tank cap.

FILL THE FUEL TANK

1. Remove the fuel tank cap.
2. Fill the tank to about 2.5 cm (one inch) below the top of the tank, not the filler neck, with No. 2 diesel fuel. Then install the cap.

DANGER

Because diesel fuel is flammable, use caution when storing or handling it. Do not smoke while filling the fuel tank. Do not fill the fuel tank while the engine is running, hot, or when the machine is in an enclosed area. Always fill the fuel tank outside and wipe up any spilled diesel fuel before starting the engine. Store the fuel in a clean, safety-approved container and keep the cap in place. Use Diesel fuel for the engine only; not for any other purpose.

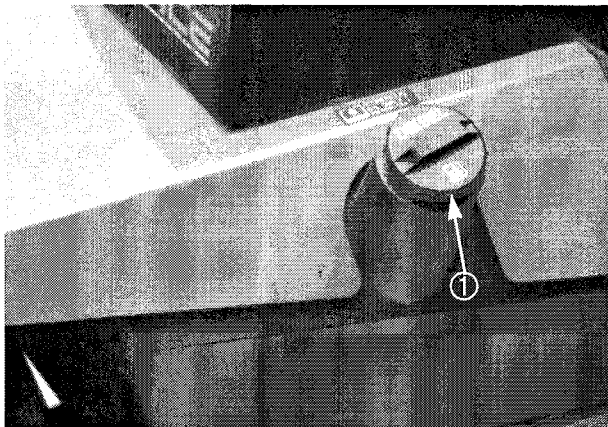

1. Fuel Tank Cap

Figure 4

CHECK THE TRANSMISSION FLUID

The front axle housing acts as the reservoir for the system. The transmission and axle housing are shipped from the factory with 4.7 l (5 quarts) of Mobil 424 engine oil. However, check the level of transmission oil before first starting the engine and daily thereafter.

1. Position the machine on a level surface, lower the

cutting units and stop the engine.

2. Unscrew the dipstick cap from the transmission filler neck and wipe it with a clean cloth. Screw the dipstick into the filler neck. Remove the dipstick and check the oil level. If the level is not within 1.2 cm (1/2 inch) from the groove in the dipstick, add enough oil to raise it to the groove mark. **DO NOT OVERFILL** by more than .6 cm (1/4 inch) above the groove.

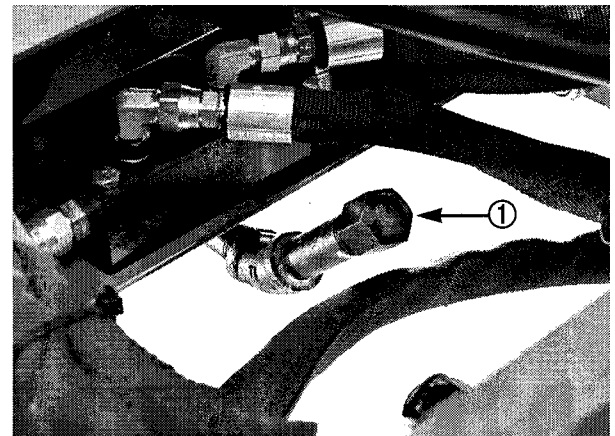

Figure 5
1. Transmission Dipstick Cap

3. Screw the dipstick filler cap finger-tight onto the filler neck. It is not necessary to tighten the cap with a wrench.

CHECK THE HYDRAULIC FLUID

The hydraulic system driving the reels is designed to operate on anti-wear hydraulic fluid. The machine's reservoir is filled at the factory with 32.2 l (8.5 gallons) of Mobil 424 hydraulic fluid. Check the level of hydraulic fluid before the first starting the engine and daily thereafter.

Group 1 Hydraulic Oil (Recommended for ambient temperatures consistently below 38° C (100° F):

ISO type 46/68 anti-wear hydraulic fluid

Mobil	Mobil Fluid 424
Amoco	Amoco 1000
International Harvester	Hy-Tran

Texaco	TDH
Shell	Donax TD
Union Oil	Hydraulic/Tractor Fluid
Chevron	Tractor Hydraulic Fluid
BP Oil	BP HYD TF
Boron Oil	Eldoran UTH
Exxon	Torque Fluid
Conoco	Power-Tran 3
Kendall	Hyken 052
Phillips	HG Fluid

Note: Oils within this group are interchangeable.

Group 2 Hydraulic Oil—Recommended for ambient temperatures consistently above 21° C (70° F):

ISO type 68 anti-wear hydraulic fluid

Mobil	DTE 26 or DTE 16
Shell	Tellus 68
Amoco	Rykon Oil 68
Arco	Duro AW S-315
Boron	Industron 53
BP Oil	Energol HLP68
Castrol	Hyspin AWS68
Chevron	Chevron EP68
Citgo	Citgo A/W68
Conoco	Super Hydraulic Oil 31
Exxon	Nuto H68
Gulf	68AW
Pennzoil	AW Hyd Oil 68
Phillips	Magnus A315
Standard	Industron 53
Texaco	Rando HD68
Union	Unax AW 315

Note: Oils within this group are interchangeable.

IMPORTANT: Two groups of hydraulic oil are specified to allow optimal operation of the machine in a wide range of temperatures encountered. The group 1 oils are a multi-viscosity hydraulic oil that allow operation at lower temperatures without the increased associated with straight viscosity oils.

The Mobil DTE 26 type oils are straight viscosity oils which remain slightly more viscous at higher tempera-

tures than the multi-viscosity oils.

Using the Mobil 424-type oils in the higher ambient temperatures may result in decreased efficiency in some hydraulic components compared to using the Mobil DTE 26 type oils.

Using the Mobil DTE 26 type oils in the lower ambient temperatures may result in harder starting, increased engine laboring while cold, sluggish or non-operating valve spools while cold and increased filter back pressure due to the higher oil viscosity.

Select the set of conditions (either ambient temperatures above 21° C (70° F) or below 38° C (100° F), and use that type of oil throughout the year, rather than changing oil types several times per year.

Note: When changing from one type of hydraulic oil to the other, remove all the old oil from the system, because some brands of one type are not completely compatible with some brands of the other type of hydraulic oil. If you always use Mobil products, the two types of oil are compatible and interchangeable.

IMPORTANT: Use only the types of hydraulic oils specified. Other fluids could cause system damage.

Note: A red dye additive for the hydraulic system oil is available in 20 ml bottles. One bottle is sufficient for 15–22 l of hydraulic oil. Order Part No. 44-2500 from your Authorized Toro Distributor

1. Position the machine on a level surface, lower the cutting units and stop the engine.
2. Clean the area around the filler neck and cap of the hydraulic tank. Remove the cap from the filler neck.
3. Remove the dipstick from the filler neck and wipe it with a clean cloth. Insert it into the filler neck; then remove it and check the fluid level. It should be within 6 mm (1/4 inch) of the mark on the dipstick.

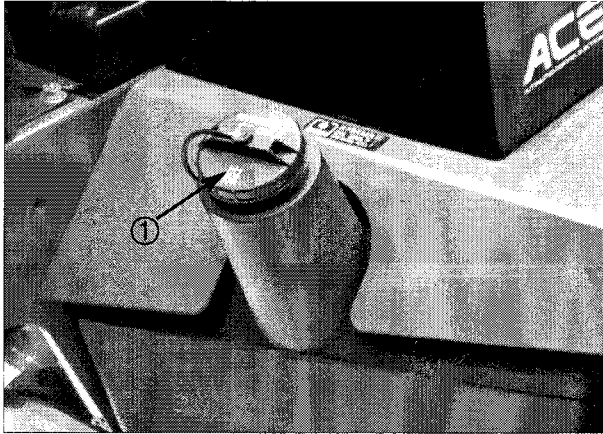

Figure 6

1. Hydraulic Tank Cap

4. If the level is low, add fluid to raise the level to the full mark.
5. Install the dipstick and cap onto the filler neck.

CHECK REAR AXLE LUBRICANT (Models 03504 and 03531 only)

The rear axle has three separate reservoirs which use SAE 80W90 weight gear lube. Although the axle is shipped with lubricant from the factory, check the level before operating the machine.

1. Position the machine on a level surface.
2. Remove a check plug from each end of axle and make sure the lubricant is up to bottom of the hole. If the level is low, remove a mounting bolt above each end plug and add enough lubricant to bring the level up to the bottom of the hole (Fig. 7).
3. Remove the plug in the center of the axle and check the level. If the level is low, add enough lubricant to bring it up to the bottom of the hole (Fig. 5).

CHECK REEL-TO-BEDKNIFE CONTACT

Each day before operating, check the reel-to-bedknife

contact, regardless of whether the quality of cut has been acceptable. There must be light contact across the full length of the reel and bedknife.

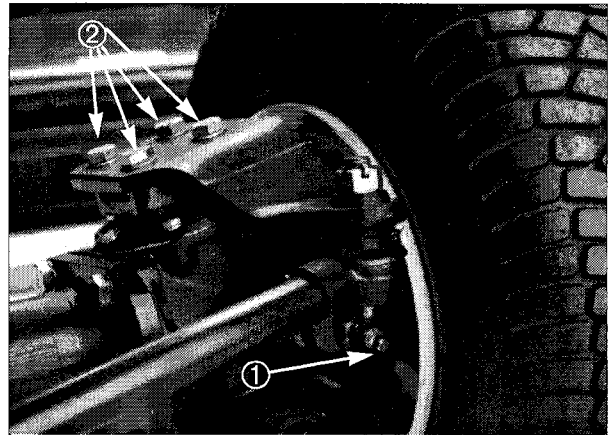

Figure 7.

1. Check Plugs (2)

2. Mounting Bolts

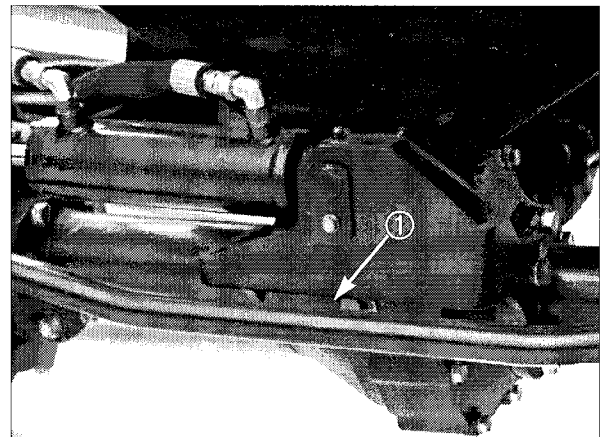

Figure 8.

1. Check/Fill Plug

CHECK WHEEL NUT TORQUE



WARNING

Tighten the wheel nuts to 45-55 lbs after 1-4 hours of operation and again after 10 hours of operation and every 250 hours thereafter. Failure to maintain correct torque could result in failure or loss of a wheel, which may result in personal injury.

Controls

Seat (Fig. 9)—The seat adjusting lever allows 10 cm (4 inches) fore and aft adjustment. The seat adjusting knob adjusts the seat for operators' weight. To adjust the seat fore and aft, pull lever on the left side of the seat assembly outward. After moving the seat to the desired location, release the lever to lock the seat into position. To adjust for the operator's weight, turn spring tension knob—clockwise to increase tension, counterclockwise to decrease spring tension.

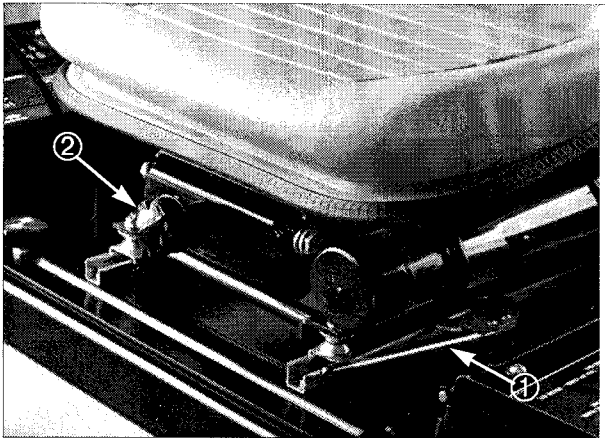

Figure 9

1. Seat adjusting level 2. Seat adjusting knob

Traction Pedal (Fig. 10)—Controls forward and reverse operation. Depress the top of the pedal to move forward and bottom to move backward. Ground speed depends on how far the pedal is depressed. For no load, maximum ground speed, fully depress the pedal while throttle is in FAST. To stop, reduce foot pressure on traction pedal and allow it to return to center position.

Traction Speed Limiter (Fig.10)—Preset this lever to limit the amount the traction pedal can be depressed in the forward direction to maintain a constant mowing speed.

Lower Mow / Raise Control Lever (Fig. 11)—The lever raises and lowers the cutting units and also starts and stops the reels.

Speedometer (Fig. 11)—Indicates ground speed at which the machine is traveling.

Fuel Gauge (Fig. 11)—Shows the amount of fuel in the tank.

Engine Oil Pressure Warning Light (Fig. 11)—Indicates dangerously low engine oil pressure.

Engine Coolant Temperature Warning Light (Fig. 11)—The light illuminates and the engine shuts down if the coolant reaches a dangerously high temperature.

Glow Plug Indicator Light (Fig. 11)—When lit, indicates glow plugs are on.

Charge Indicator (Fig. 11)—Illuminates when system charging circuit malfunctions.

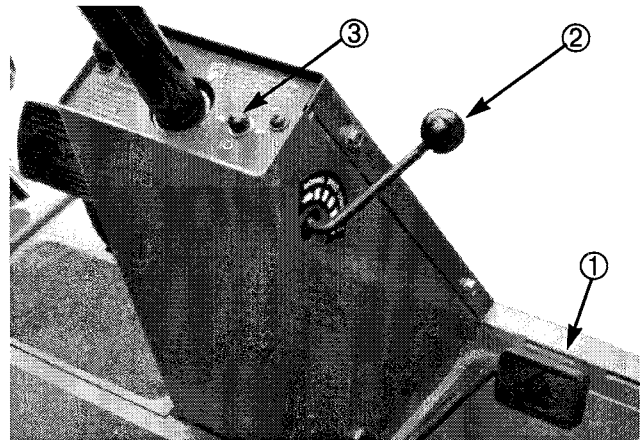

Figure 10

1. Traction pedal
2. Traction speed limiter
3. Reel control light

Key Switch (Fig. 11)—Three positions: OFF, ON/Preheat and START.

Throttle Control (Fig. 11)—Move the control forward to increase engine speed, rearward to decrease speed.

Enable/Disable Switch (Fig.11)—Used in conjunction

with lower mow / raise the control lever to operate reels.

Reel Control Light (Fig. 11)—When lit, indicates the machine is being operated in a way in which the automatic reel speed control cannot obtain the desired clip.

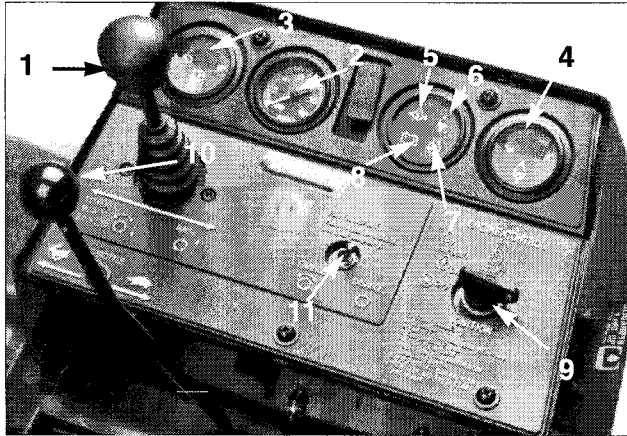

Figure 11

- 1. Lower Mow/Raise Control Lever
- 2. Speedometer
- 3. Fuel Gauge
- 4. Engine Coolant Temperature Gauge
- 5. Engine Oil Pressure Warning Light
- 6. Engine Coolant Temperature Warning Light.
- 7. Glow Plug Indicator Light
- 8. Charge Indicator
- 9. Key Switch
- 10. Throttle Control
- 11. Enable/Disable Switch
- 12. Reel Control

Backlap Switch (Fig. 12)—Used with lower mow / raise control lever for backlapping operation.

Height-of-Cut Selector Knob (Fig. 13)—Turning the knob to the appropriate setting informs the electronic controller at what height of cut the machine is being operated so desired clip may be obtained.

5 / 8 Blade Switch (Fig. 13)—Moving the switch to the correct setting informs the electronic controller whether the machine is equipped with a 5- or 8-blade cutting unit.

Hour Meter (Fig. 13)—Shows the total hours the machine has been operated.

Brake Pedals (Fig. 11)—Two foot pedals operate indi-

vidual wheel brakes for turning assistance, parking and to aid in sidehill traction. A Locking pin connects the pedals for parking brake operation and transport.

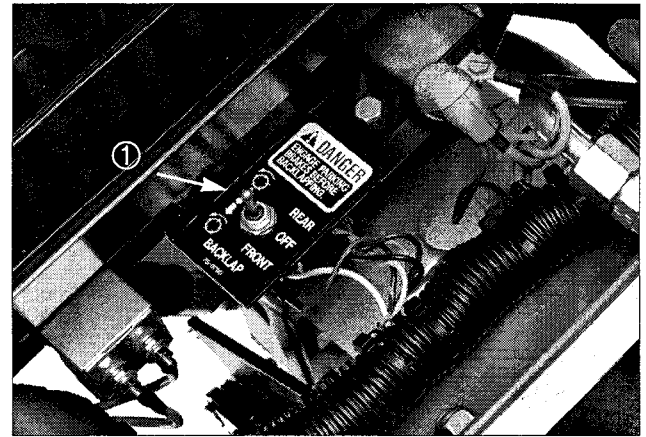

Figure 12

- 1. Backlap Switch

Parking Brake Latch (Fig. 14)—A knob on the left side of the console actuates the parking brake lock. To engage the parking brake, connect the pedals with the locking pin, push down on both pedals and pull the parking brake latch out. To release the parking brake, depress both pedals until the parking brake latch retracts.

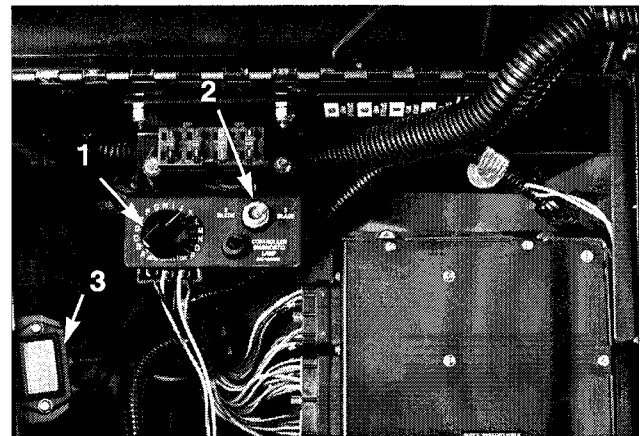

Figure 13

- 1. Height of Cut Selector Knob
- 2. 5 / 8 Blade Switch
- 3. Hour Meter

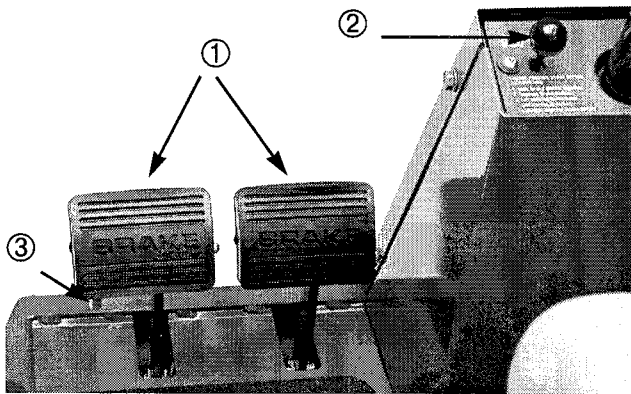

Figure 14

1. Brake Pedals
2. Parking Brake Latch
3. Locking Pin

Operation



CAUTION

Before servicing or making adjustments to the machine, stop the engine and remove the key from the switch.

STARTING AND STOPPING

IMPORTANT: The fuel system must be bled if any of the following situations have occurred.

- A. Initial start up of a new machine.
- B. The engine has ceased running due to lack of fuel.
- C. Maintenance has been performed upon fuel system components; i.e., filter replaced, separator serviced, etc.

Refer to *Bleeding The Fuel System*

1. Sit on the seat, keeping your foot off the traction pedal. Assure the parking brake is engaged, the traction pedal is in NEUTRAL, the throttle is in the SLOW position and the ENABLE / DISABLE switch is in the DISABLE position.

2. Turn the ignition switch to the ON/Preheat position. An automatic timer will control preheat for 6 seconds. After preheat, turn the key to START. **CRANK THE ENGINE FOR NO LONGER THAN 15 SECONDS.** Release the key when the engine starts. If additional preheat is required, turn the key to OFF then to the ON/Preheat position. Repeat the process as needed.
3. Run the engine at idle speed or partial throttle until the engine warms up.
4. To stop, move all controls to NEUTRAL and set the parking brake. Return the throttle to the idle position, turn the key to OFF and remove it from switch.

BLEEDING THE FUEL SYSTEM

1. Raise the hood over the engine.
2. Loosen the air bleed screw on top of the fuel filter/water separator (Fig. 15)

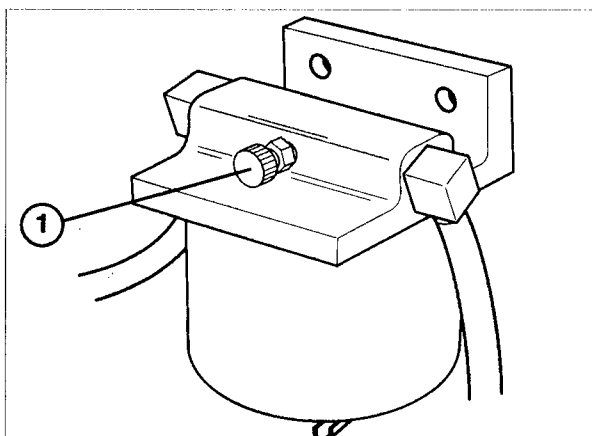

Figure 15

1. Air Bleed Screw

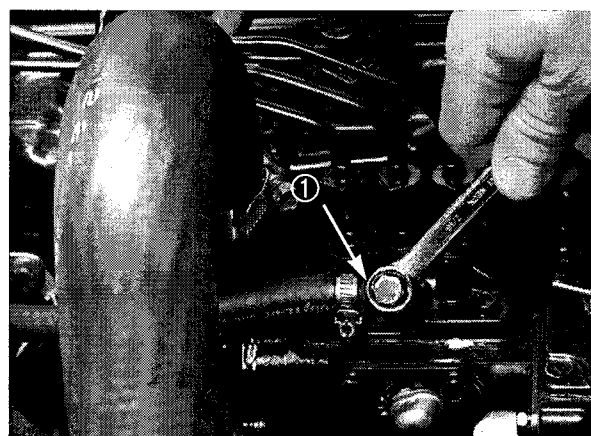

Figure 16

1. Fuel injection Pump Bleed Screw

3. Turn the key in the ignition switch to ON. The electric fuel pump will begin operation, forcing air out around the air bleed screw. Leave the key in the ON position until a solid stream of fuel flows out around the screw. Tighten the screw and turn the key to OFF.
4. Open the air bleed screw on the fuel injection pump with a 12 mm wrench.
5. Turn the key in the ignition switch to ON. The electric fuel pump will begin operation, forcing air out around the air bleed screw on the fuel injection pump. Leave the key in the ON position until a solid stream of fuel flows out around the screw. Tighten the screw and turn the key to OFF.

Note: Normally the engine should start after the above bleeding procedures. However, if the engine does not start, air may be trapped between the injection pump and the injectors; refer to *Bleeding Air From The Injectors*.

AUTOMATIC CLIP CONTROL

The RM 5100-D and 5300-D are equipped with an electronic controller which is programmed for automatic clip control. The machine will automatically adjust the reel speed to attain the desired clip as the traction speed changes. For the controller to know what clip is desired, the operator must input the number of blades on the reels and the height of cut setting of the machine.

The range of possible reel speeds is a minimum of about 600 RPM and a maximum of about 1,800 RPM. As long as the desired clip requires a reel speed within this range, the machine will maintain the desired clip. If the traction speed is too slow or too fast to allow the desired clip, the Reel Control light (on the front control panel) will illuminate, indicating that the desired clip is not being maintained. For example, if the traction speed is zero, the reels will still run at the minimum speed of about 600 RPM, which will result in a clip smaller than desired and cause the Reel Control light to illuminate. The ranges of traction speed that will result in the desired clip are as follows for several of

No. of Blades per C.U.	Height of Cut	Minimum Traction Speed	Maximum Traction Speed
8	6 mm (0.25 in.)	1.9 kmh (1.2 mph)	6.4 kmh (4.0 mph)
8	12 mm (0.50 in.)	4.0 kmh (2.5 mph)	12.9 kmh (8.0 mph)
5	12 mm (0.50 in.)	2.7 kmh (1.7 mph)	8 kmh (5.0 mph)
5	2 cm (0.88 in.)	4.3 kmh (2.7 mph)	13.4 kmh (8.3 mph)

the possible heights of cut:

SELECTING CLIP RATE (REEL SPEED)

To achieve a consistent, high quality of cut, and a uniform after-cut appearance, it is important that the reel speed be matched to the height of cut. The machine controller is programmed to automatically control the reel speed to give the correct clip, even as the traction speed changes. To control the reel speed as desired, the controller must know the height of cut of the machine, and whether the machine is equipped with 5- or 8-blade reels.

Adjust the height-of-cut selector knob as follows:

1. Set the 5 / 8 blade switch to the setting indicating the type of cutting units mounted on the machine.
2. Verify the height-of-cut settings on the cutting units. Using the column of the chart listing either 5- or 8-blade reels, look down the chart to find the height-of-cut listing nearest the actual height-of-cut setting. Look across the chart to find the letter corresponding to that height of cut.
3. Turn the height-of-cut selector knob to the letter setting determined in step 2.
4. Operate the machine for several days until the grass being cut is "conditioned" to being mowed with this machine. Then examine the cut to

ensure satisfaction with the quality of cut. The height-of-cut knob may be set one position on either side of the position shown on the chart to account for differences in grass condition, grass length removed, and the personal preference of the superintendent.

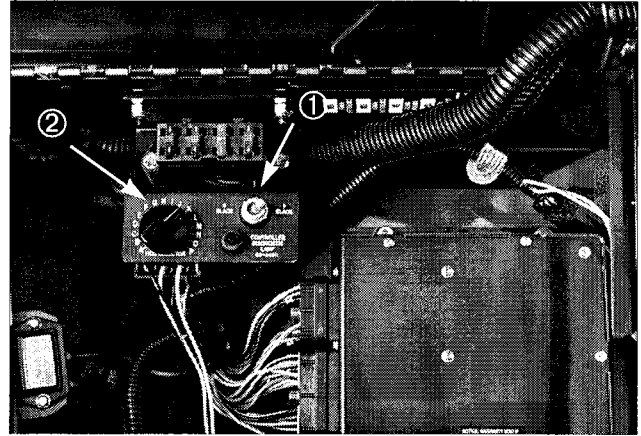

Figure 17

1. 5/8 blade switch
2. Height of cut selector knob

Full Speed—There may be times when it is desirable for the reels to run at full speed, regardless of the traction speed of the machine. Examples of this are vertical cutting or heavy scalping. In such cases, the height-of-cut selector knob may be set to position "A", which will direct the machine controller to run the reels at full speed at all times. Also, set the height-of-cut selector knob to position "A" when troubleshooting the electrical system.

CLIP RATE (REEL SPEED) SELECTIONS CHART

8-Blade Cutting Unit

Height of Cut Knob Position	Height of Cut
A	Full Speed
B	6.4 mm
C	7.6 mm
D	8.9 mm
E	10.2 mm
F	11.4 mm
G	12.7 mm
H	14.0 mm
I	15.2 mm
J	16.5 mm
K	17.8 mm
L	19.0 mm
M	20.3 mm
N	21.6 mm
O	22.9 mm
P	24.1 mm

5-Blade Cutting Unit

Height of Cut Knob Position	Height of Cut
A	Full Speed
B	12.7 mm
C	14.0 mm
D	15.2 mm
E	16.5 mm
F	17.8 mm
G	19.0 mm
H	20.3 mm
I	21.6 mm
J	22.9 mm
K	24.0 mm
L	25.4 mm
M	27.0 mm
N	30.0 mm
O	33.0 mm
P	36.0 mm

FULL SPEED—Cutting units always set to full speed in this position.

REEL CONTROL LIGHT

The Reel Control light on the front control panel is used to tell the operator that the machine controller is able to achieve the desired clip. If the machine is operated at a traction speed which is too low or too high, the machine controller may not be able to set the reel speed at the required value to achieve the desired clip. If this occurs, the Reel Control light will illuminate.

If the reel control light illuminates, it means one of the following things:

1. The machine is being operated at a traction speed

too slow to allow desired clip.

2. The machine is being operated at a traction speed too fast to allow desired clip. To correct the situation, change the traction speed until the light goes out.
3. A foreign object, such as a stick, piece of turf, etc., is stuck in the reel, restricting rotation.

If changing the traction speed does not cause the light to go out, and the reel control light remains illuminated regardless of traction speed, then a service issue is required. In this case contact your local authorized

Toro Distributor.

ADJUSTING LIFT ARM DOWN PRESSURE

The down pressure spring on each cutting unit lift arm can be adjusted to compensate for different turf conditions. Increased down pressure will help keep the cutting units on the ground when mowing at higher speeds and helps maintain a uniform height-of-cut in rough conditions or in areas of thatch build-up.

Each down pressure spring may be adjusted to one of four settings. Each increment increases or decreases down pressure on cutting unit by 3 kg (8 lbs.).

1. Position the machine on a level surface, lower the cutting units, stop the engine, engage the parking brakes and remove the key from the ignition switch.



Springs are under tension, use caution when adjusting.

2. Remove the floor plate in front of the seat and open the hood to gain access to all (5) springs.

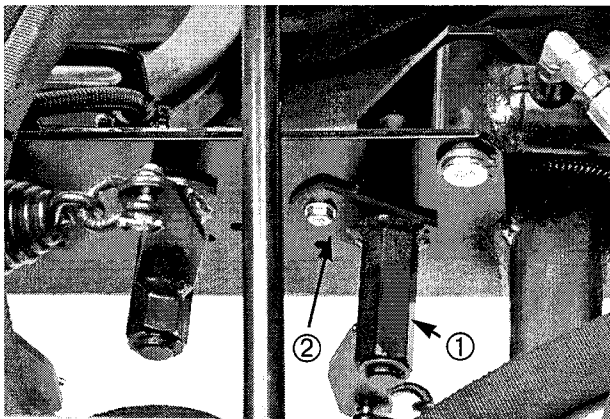

Figure 18

1. Spring Bracket Hex Shaft
2. Retaining Bracket

3. Place an open end wrench on the hex shaft of the spring bracket.

4. Remove the capscrew and locknut securing retaining bracket while rotating hex shaft to relieve spring tension.
5. Move the spring bracket to the desired location and install the capscrew and locknut, while turning the hex shaft to relieve spring tension.

TOWING THE TRACTION UNIT

If it becomes necessary to tow the machine, tow it forward only and at a speed no greater than 16 kmh (10 mph).

Note: If you exceed these towing limits, severe damage to the hydrostatic transmission may occur.

To tow a disabled machine:

1. Loosen and remove the capscrews securing the drive shaft to the engine. Loosen the capscrews clamping the drive shaft to transmission (Fig. 19). Remove the drive shaft.

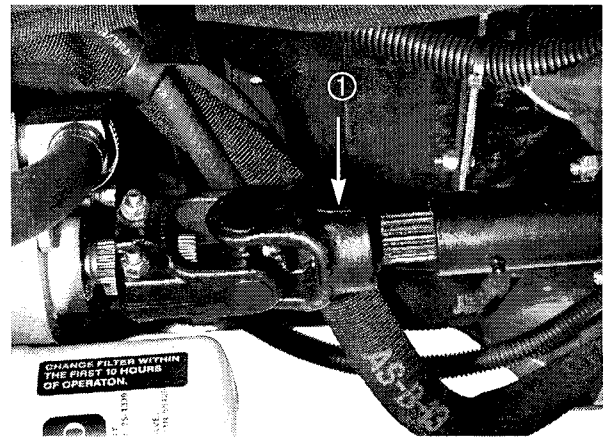

1. Antriebswelle

Bild 19

Important: If the drive shaft is not removed before towing, the transmission input shaft will not be able to rotate, not the allowing transmission to maintain its internal lubrication. Severe damage to the transmission may occur.

2. Attach a suitable chain, strap or cable to the center of the front frame member (Fig. 20).

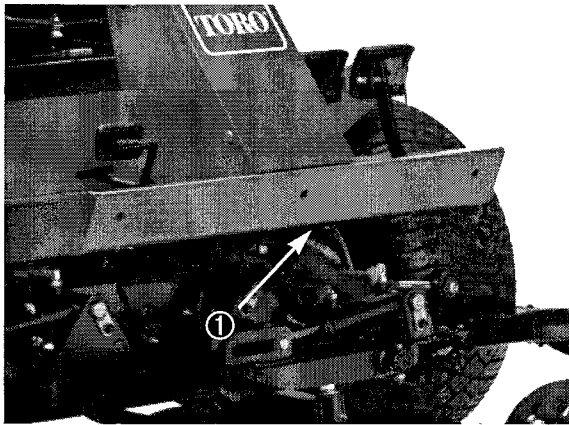

Figure 20

1. Center of Front Frame Member

HEIGHT-OF-CUT SELECTION POTENTIOMETER REPLACEMENT

The height-of-cut selection potentiometer is factory calibrated. If the height-of-cut selection potentiometer should be replaced for any reason, the new potentiometer must be calibrated to assure correct clip. If the potentiometer is not calibrated correctly, the clip may be as much as 2 or 3 settings different from the desired setting. This calibration must be done by your Toro distributor.

Note: Lock both brake pedals together before towing.

3. Attach the other end of the towing device to a vehicle that is capable of towing the machine safely at speeds below 16 kmh (10 mph).
4. An operator must be on the machine to steer it and keep the traction pedal fully depressed in the forward position while towing.
5. When towing is completed, reinstall the drive shaft as shown in Figure 19. (The splines are designed to allow assembly only when the two halves of the shaft are properly oriented.)

HYDRAULIC VALVE SOLENOID FUNCTIONS

Use the list below to identify and describe the different functions of the solenoids in the hydraulic manifold. Each solenoid must be energized for the function to occur.

Solenoid	Function
VS1,S1	Front reel circuit
VS2,S2	Rear reel circuit
S3	Lift / lower front wing cutting units
S4	Lift / lower center cutting unit
S5	Lift / lower rear cutting unit
S6	Lower any cutting units
S7	Lift any cutting units
S8,S9	Backlap any cutting units

OPERATING CHARACTERISTICS



CAUTION

When operating the machine, always use the seat belt and Roll-over Protection System together.

Familiarization—Before mowing grass, practice operating the machine in an open area. Start and stop the engine. Operate in forward and reverse. Lower and raise the cutting units and engage and disengage the reels. When you feel familiar with the machine, practice operating up and down slopes at different speeds.

The brakes can be used to assist in turning the machine. However, use them carefully, especially on soft or wet grass conditions because the turf may be torn accidentally. Individual turning brakes may also be used to help maintain traction. For example, in some slope conditions, the uphill wheel slips and loses traction. If this situation occurs, depress the uphill turn pedal gradually and intermittently until the uphill wheel stops slipping, thus, increasing traction on the downhill wheel.

Warning System—If a warning light comes on during operation, stop the machine immediately and correct the problem before continuing operation. Serious damage could occur if the machine is operated with a malfunction.

Mowing—Start the engine and move the throttle to FAST so the engine is running at maximum speed. Move the ENABLE / DISABLE switch to ENABLE and use the LOWER MOW / RAISE lever to control the cutting units (front cutting units are timed to lower before the rear cutting units). To move forward and cut grass, press the traction pedal forward. Maintain a speed which does not result in the Reel Control Light illuminating. Gradually increase or decrease traction speed to ensure proper clip.

Transport—Move the ENABLE / DISABLE switch to DISABLE and raise the cutting units to the transport position. Be careful when driving between objects so you do not accidentally damage the machine or cutting units. Use extra care when operating the machine on

slopes. Drive slowly and avoid sharp turns on slopes to prevent roll overs. The cutting units should be lowered when going downhill for steering control.

Selecting Clip Rate (Reel Speed)—The automatic clip control programmed into the machine controller requires that it be told at what height of cut the machine is being operated and whether the machine is equipped with 5- or 8-blade reels. Refer to Selecting Clip Rate (Reel Speed).

When the machine is being operated in such a way that it can control the reel speed to achieve the desired clip, the Reel Control light will not light. If the Reel Control light is illuminated, the traction speed is too low or too high to allow the machine to achieve the desired clip.

Maintenance

CAUTION

Before servicing or making adjustments to the machine, stop the engine and remove the key from the switch.

GREASING BEARINGS AND BUSHINGS

The machine has grease fittings that must be lubricated regularly with No. 2 General Purpose Lithium Base Grease. If the machine is operated under normal conditions, lubricate all bearings and bushings after every 25 hours of operation.

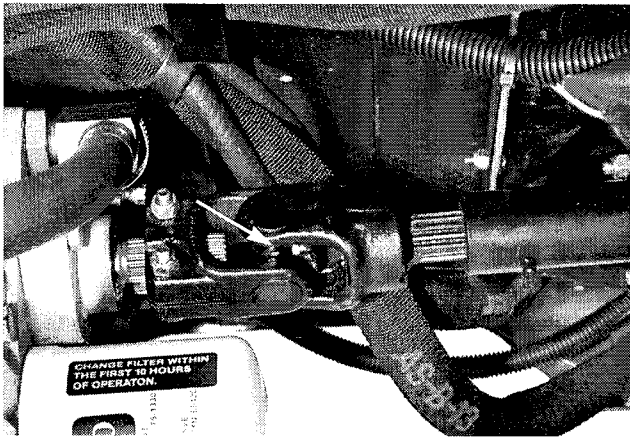

Figure 24

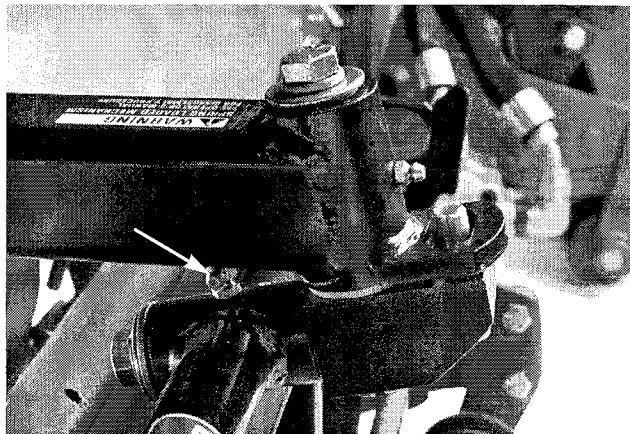

Figure 25

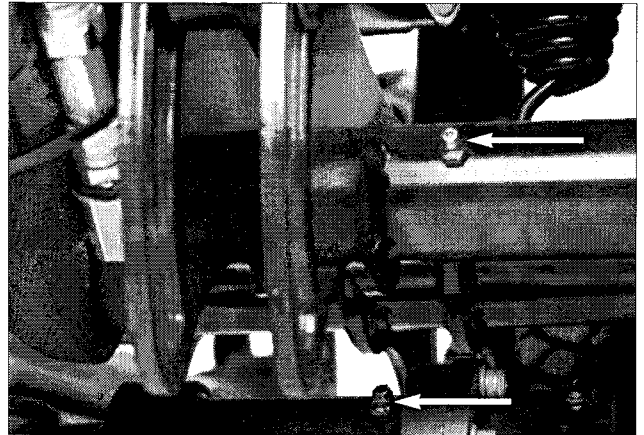

Figure 26

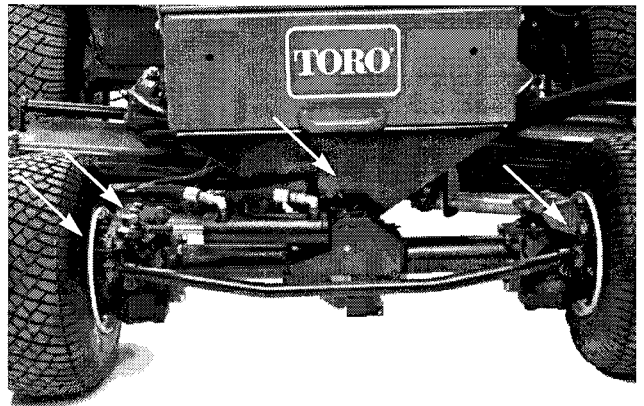

Figure 27

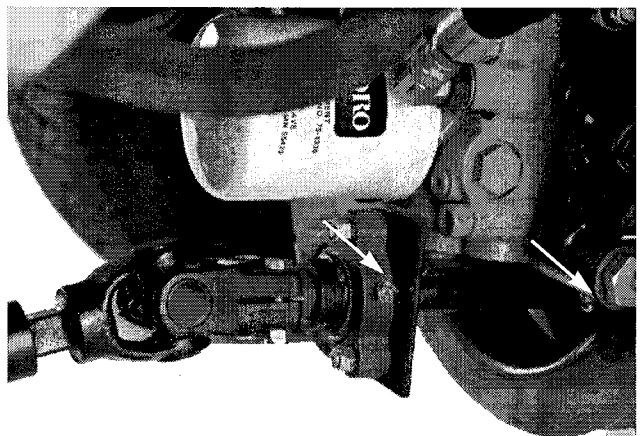

Figure 28

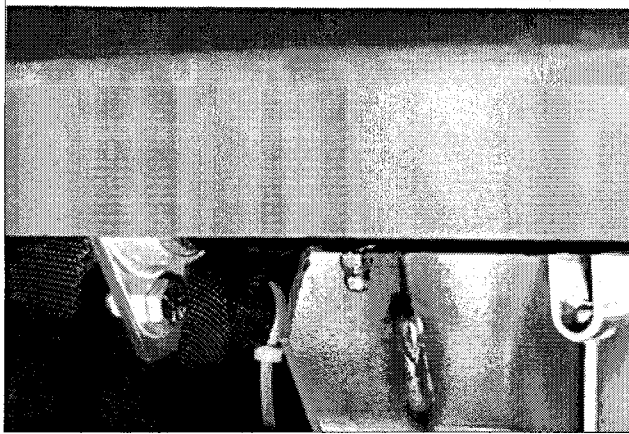

Figure 29

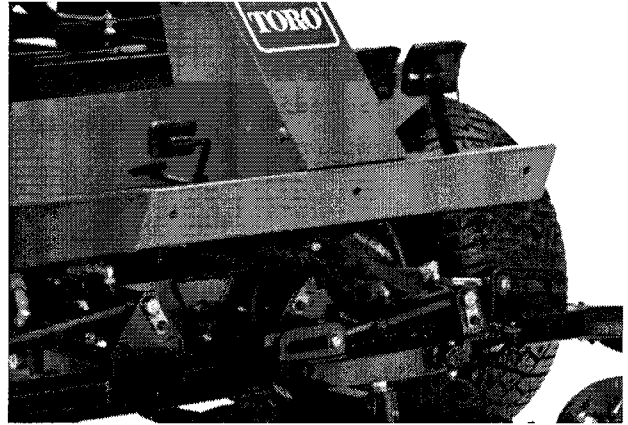
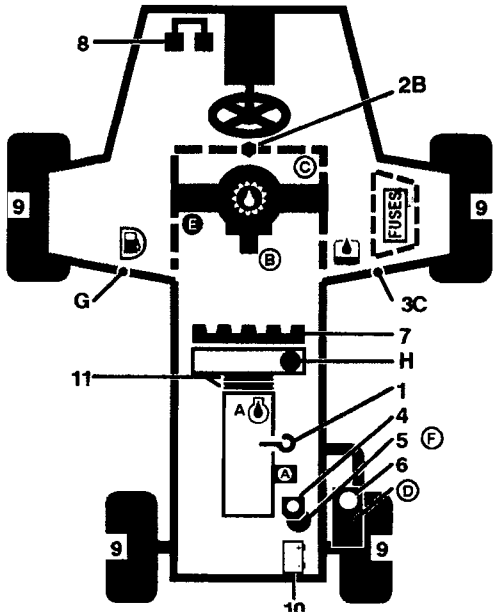

Figure 30



CHECK/SERVICE (DAILY)

- | | |
|------------------------------|----------------------|
| 1. Oil level, engine | 7. Radiator screen |
| 2. Oil level, transmission | 8. Brake function |
| 3. Oil level, hydraulic tank | 9. Tire pressure |
| 4. Coolant level, radiator | 10. Battery |
| 5. Fuel/Water separator | 11. Belts (Fan, alt) |
| 6. Precleaner—air cleaner | |

FLUID · SPECIFICATIONS/CHANGE · INTERVALS. ¶

	FLUID TYPE	CAPACITY	CHANGE FLUID-	INTERVAL FILTER	FILTER PART NO.
ENGINE OIL	SAE 10W-30	3.7 l	50 hours	100 hours	67-4330
TRANSMISSION OIL	Mobil 424	4.7 l*	800 hours	800 hours	75-1330
HYDRAULIC CIRCUIT OIL	Mobil 424	32.2 l*	800 hours	When indicator is in red zone	75-1310
AIR CLEANER				400 hours	27-7110
FUEL PUMP				400 hours	43-2550
WATERSEPARATOR				400 hours	63-8300
FUEL TANK	NO. 2-Diesel	37.9 l	Drain & Flush—	2 years	
COOLANT	50/50 Ethylene glycol/water	9.1 l	Drain & Flush—	2 years	

*including filter ¶



Figure 31

- 1. Pre Cleaner Bowl

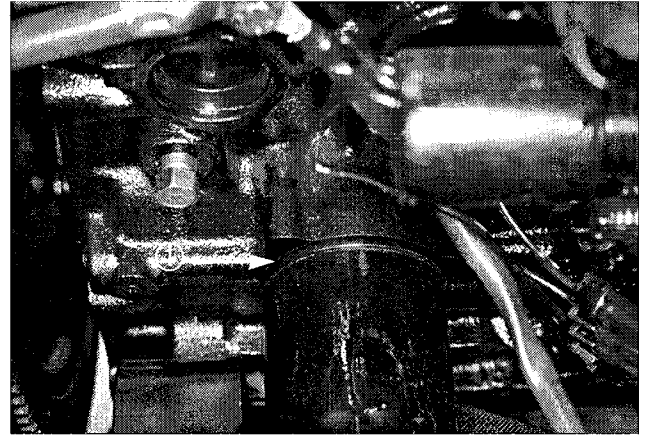

Figure 34

- 1. Engine Oil Filter

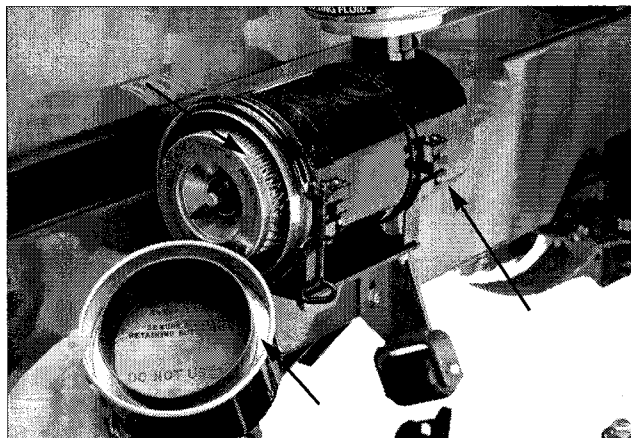

Figure 32

- 1. Dust Cup & Baffle
- 2. Filter Element
- 3. Air Cleaner Body

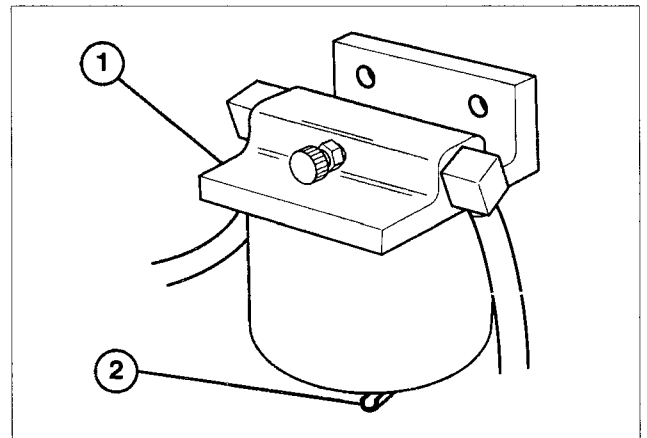

Figure 35

- 1. Fuel Filter/Water Separator
- 2. Drain plug

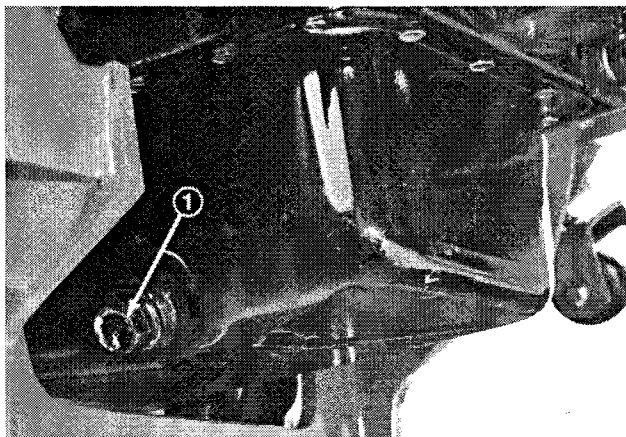

Figure 33

- 1. Engine Oil Drain Plug

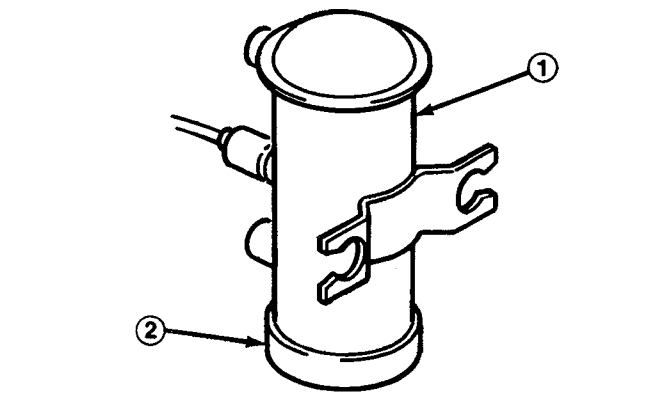

Figure 36

- 1. Fuel pump
- 2. Cover

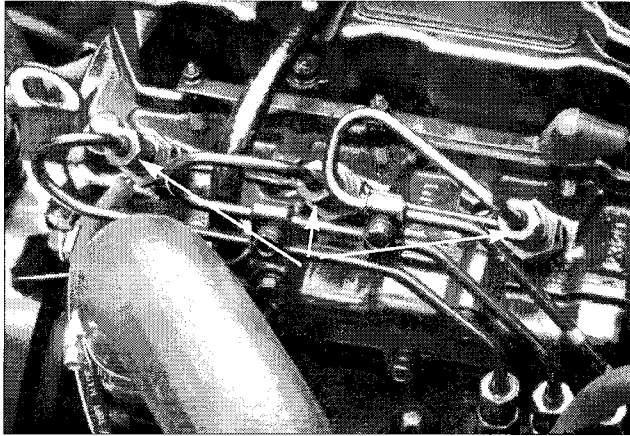

Figure 37

- 1. Fuel Injectors (3)

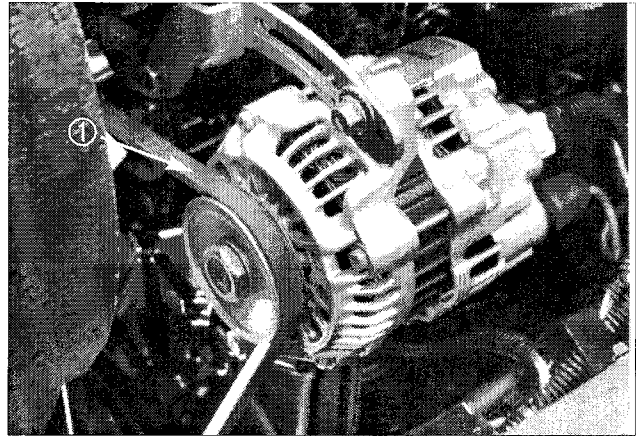

Figure 40

- 1. Alternator Belt

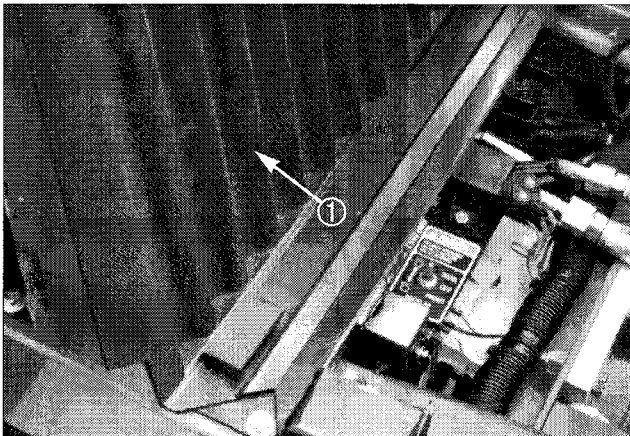

Figure 38

- 1. Pull up screen and slide it out of the mounting tracks. Clean it thoroughly with water or compressed air.

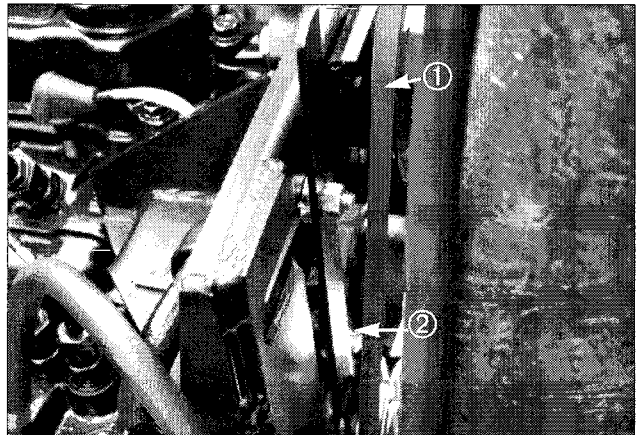

Figure 41

- 1. Cooling Fan Belt
- 2. Tensioner Lever

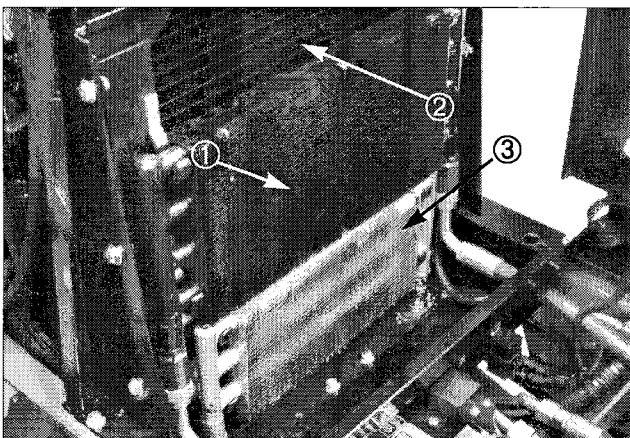

Figure 39

- 1. Oil Cooler
- 2. Radiator
- 3. Transmission Oil Cooler

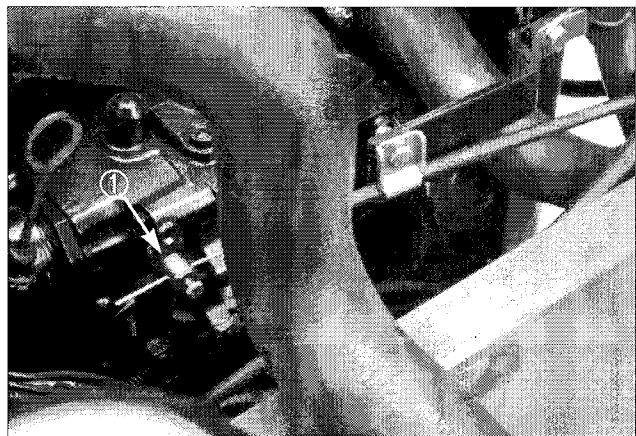

Figure 42

- 1. Injection Pump Lever Arm

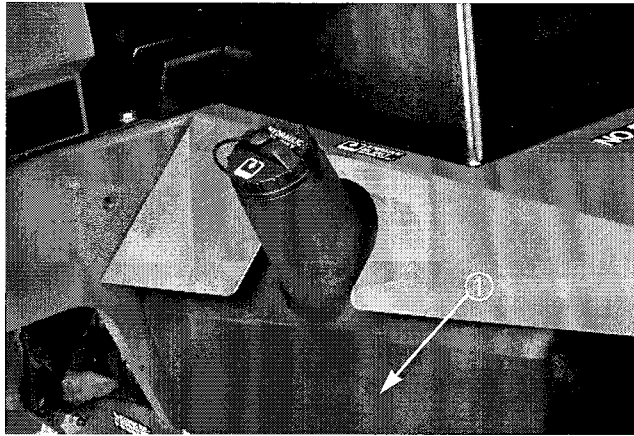

Figure 43

1. Hydraulic Reservoir

IMPORTANT: Use only hydraulic oils specified. Other fluids could cause system damage.

REPLACING THE HYDRAULIC FILTER

The hydraulic system filter head is equipped with a service interval indicator. With the engine running, view the indicator; it should be in the GREEN zone. When the indicator is in the RED zone, the filter element should be changed. Use the Toro replacement filter (Part No. 75-1310).

IMPORTANT: Use of any other filter may void the warranty on some components.

CHECKING HYDRAULIC LINES AND HOSES

After every 100 operating hours, check hydraulic lines and hoses for leaks, kinked lines, loose mounting supports, wear, loose fittings, weather deterioration and chemical deterioration. Make all necessary repairs before operating.

WARNING

Keep your body and hands away from pin-hole leaks or nozzles that eject high-pressure hydraulic fluid. Use cardboard or paper to find hydraulic leaks. Hydraulic fluid escaping under pressure can penetrate skin and cause injury. Fluid accidentally injected into the skin must be surgically removed within a few hours by a doctor familiar with this form of injury or gangrene may result.

ADJUSTING THE TRACTION DRIVE FOR NEUTRAL

The machine must not creep when traction pedal is released. If it does creep, an adjustment is required.

1. Park the machine on a level surface, shut the engine off and lower the cutting units to the floor. Depress only the right brake pedal and engage the parking brake.
2. Jack up the left side of the machine until the front tire is off the shop floor. Support the machine with jack stands to prevent it from falling accidentally.
3. Under the right side of the machine, loosen the locknut on the traction adjustment cam.

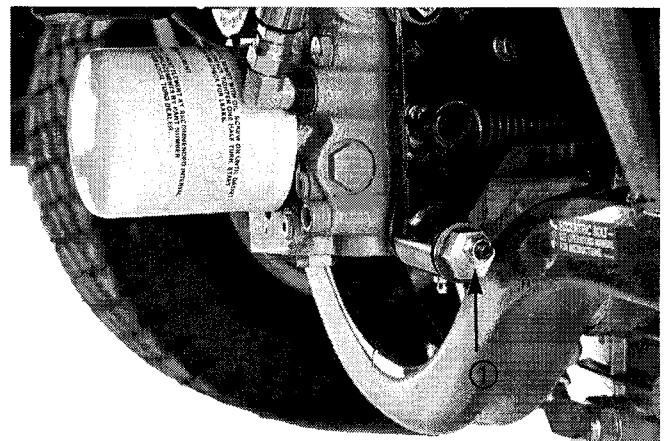

Figure 44

1. Traction Adjustment Cam

WARNING

The engine must be running for the final adjustment of the traction cam. To guard against possible personal injury, keep hands, feet, face and other parts of the body away from the muffler, other hot parts or the engine, and other rotating parts.

4. Start the engine and rotate the cam hex in either direction until the wheel ceases rotation.
5. Tighten the locknut securing adjustment.
6. Stop the engine and release the right brake. Remove the jack stands and lower the machine to the shop floor. Test drive the machine to make sure it does not creep.

ADJUSTING THE CUTTING UNIT LIFT RATE

The cutting unit lift circuit is equipped with (2) adjustable valves used to ensure the center and rear cuttings units do not raise too quickly and bang against lift stops. Adjust the cutting units as follows:

Center Cutting Unit

1. Locate the valve behind the access panel above the operator's platform.

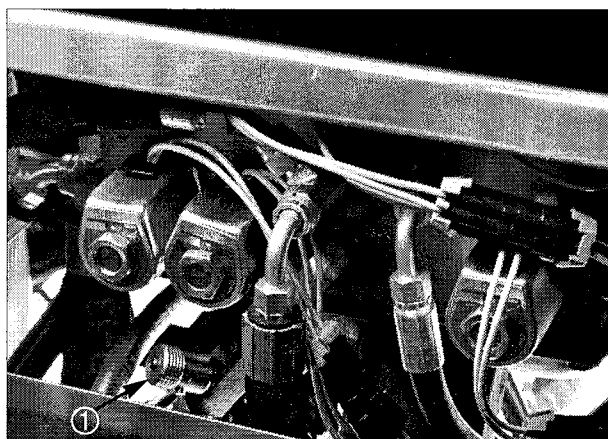

Figure 44

1. Center cutting unit adjustment valve.

2. Loosen the setscrew on the valve and rotate the valve approximately one turn clockwise.
3. Verify lift rate adjustment by raising and lowering the cutting unit several times. Readjust as required.
4. After the desired lift rate is attained, tighten the setscrew to lock adjustment.

Rear Cutting Units

1. Raise the hood and locate the valve on the left rear side of the machine.
2. Loosen the setscrew on the valve and rotate the valve approximately one turn clockwise.
3. Verify the lift rate adjustment by raising and lowering the cutting units several times. Readjust as required.
4. After the desired lift rate is attained, tighten the setscrew to lock adjustment.

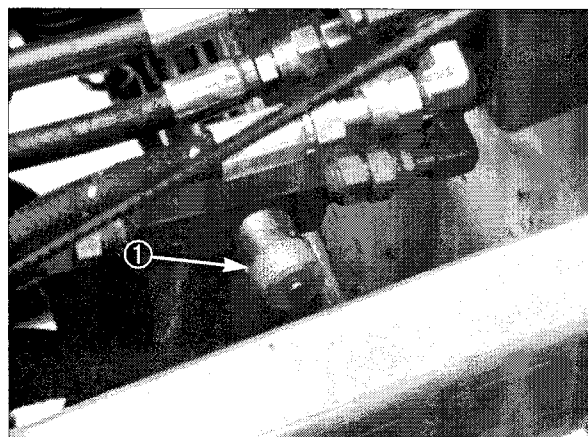

Figure 46

1. Rear cutting units adjustment valve.

CHECKING AND ADJUSTING TRACTION LINKAGE

Due to normal wear in the control linkage and hydrostatic transmission, an increased amount of force may be required to return the transmissions to neutral. Periodically check the machine.

To Check Traction Linkage

1. On a large, flat open area, drive the machine at full throttle and full traction speed.
2. Remove your foot from the traction pedal and measure the distance required for the machine to come to a stop.
3. If the distance required to stop is greater than 5.5 meters, (18 feet) an adjustment to the traction linkage is required. Go to the next step.

To Adjust Traction Linkage

1. Park the machine on a level surface, lower the cutting units to the floor and shut the engine off.
2. Connect the brake pedals together with the locking pin, push both pedals down and pull the parking brake latch out.
3. Loosen the outer hex nut securing the eye bolt to the spring anchor plate.

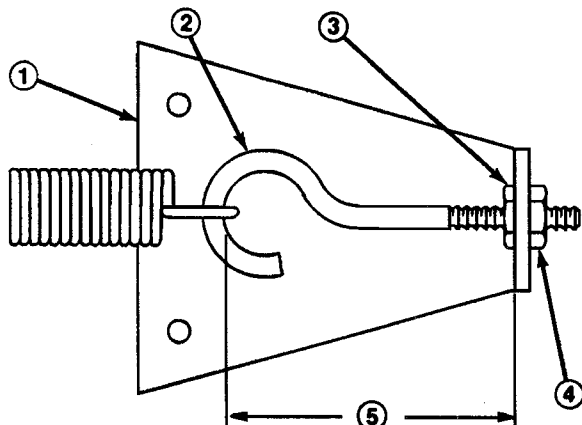

Figure 45

1. Spring Anchor Plate
2. Eye bolt
3. Inner locknut
4. Outer Locknut

4. Shorten the distance to decrease the time required to stop the machine.
5. Rotate clockwise, until the distance between inside of the eye bolt loop and inside of spring anchor plate is shortened 3 mm (1/8"). Tighten the

hex nut.

6. Operate the machine and check stopping distance. Repeat procedure if required.

Note: Shortening the distance between the inside of the eye bolt loop and the inside of the spring anchor plate increases the force on the traction pedal. Do not over adjust.

CHANGING TRANSMISSION OIL

Change the transmission oil after every 800 hours of operation, in normal conditions.

1. Position the machine on a level surface, lower the cutting units, stop the engine, engage the parking brakes and remove the key from the ignition switch.
2. Clean the area around the suction line on the bottom of the transmission. Place the drain pan under the line.
3. Remove the line from the transmission, allowing the oil to drain into the drain pan.

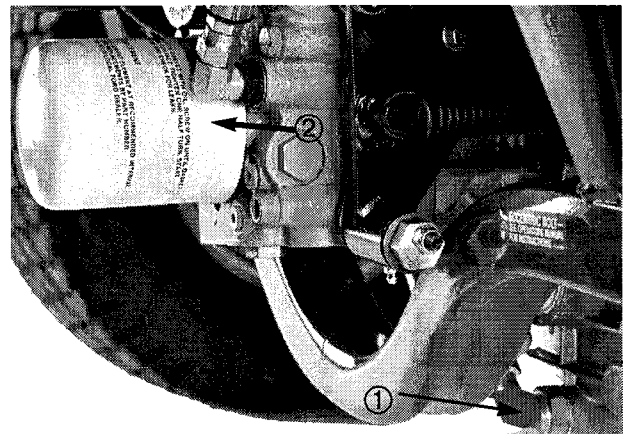

Figure 46

1. Transmission Suction Line
2. Transmission Oil Filter

4. Reinstall the suction line to the transmission.
5. Fill with oil.

- Before starting the engine after changing transmission oil, disconnect the run (ETR) solenoid on the engine, and crank the engine several times for 15 seconds. This allows the charge pump to fill the transmission with oil before the engine is started.

CHANGING REAR AXLE LUBRICANT (Models 03504 and 03531 only)

After every 500 hours of operation the oil in the rear axle must be changed.

- Position the machine on a level surface.
- Clean area around the (3) drain plugs, (1) on each end and (1) in the center.

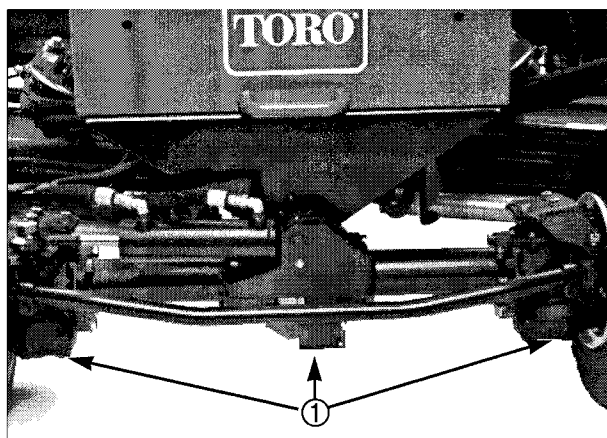

Figure 47

1. Drain Plugs (3)

- Remove plugs allowing the oil to drain into drain pans.
- After the oil is drained, apply thread locking compound on drain plug threads and reinstall in the axle.
- Fill the axle with lubricant.

REAR WHEEL TOE-IN

After every 800 operating hours or annually, check the rear wheel toe-in.

- Measure center-to-center distance (at axle height) at the front and rear of the steering tires. The front measurement must be 3 mm less than the rear measurement.
- To adjust, loosen the clamps at both ends of the tie rod.

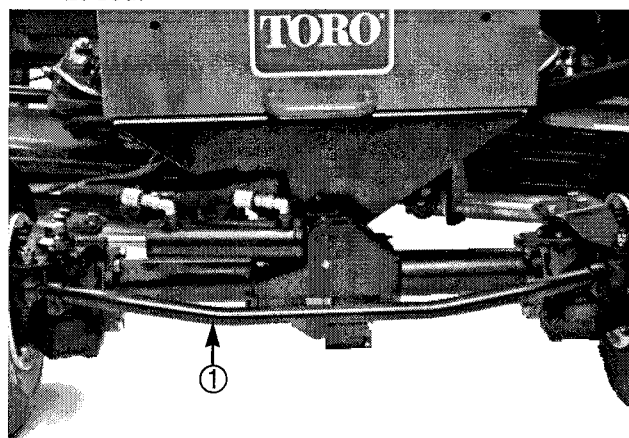

Figure 48

1. Tie Rod(s)

- Rotate the tie rod(s) to move the front of the tire inward or outward.
- Tighten the tie rod clamps when the adjustment is correct.

FUSES

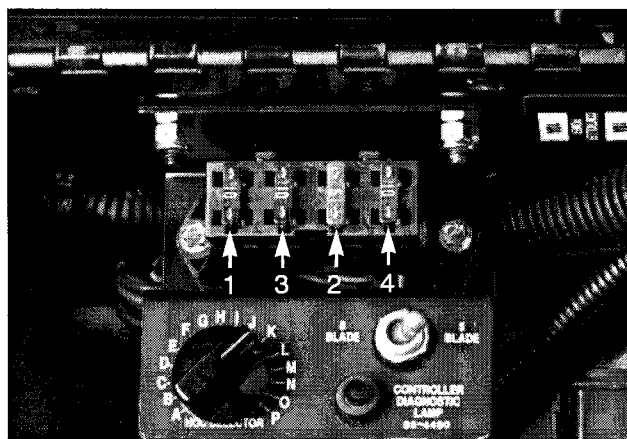

Figure 49

- Controller Power
- Ignition Switch
- Controller Power
- Controller Power

CUTTING UNIT MAINTENANCE

BACKLAPPING

Note: When backlapping, the front units all operate together, and the rear units operate together.

1. Position the machine on a level surface, lower the cutting units, stop the engine, engage the parking brake, and move the Enable/Disable switch to the Disable position.

DANGER

To avoid personal injury, never place hands or feet in the reel area while the engine is running. Changing engine speed while backlapping may cause reels to stall. Never change engine speed while backlapping. Only backlap at idle engine speed. Never attempt to turn reels by hand or foot while the engine is running.

DANGER

Reels may stall while backlapping. Do not attempt to restart reels by hand or while backlapping. Stop the engine and turn the height of cut knob one position toward "A".

2. Unlock and raise the seat to expose controls.
3. Open the control cover and turn the height-of-cut selection knob to position "P".
4. Make initial reel-to-bedknife adjustments appropriate for backlapping on all cutting units that are to be backlapped.
5. Start the engine and run at idle speed.
6. Select either the front or rear on the backlap switch to determine whether the front or rear reels will be backlapped.
7. Move Enable/Disable switch to the Enable position. Move the Lower Mow / Lift control forward to start back-lapping operation on designated reels.

DANGER

To avoid personal injury, be certain that you are clear of the cutting units before proceeding.

8. Apply lapping compound with the long handle brush supplied with the machine. Never use a short-handled brush.
9. If the reel to be backlapped turns too slowly, or erratically, stop the engine and turn height-of-cut knob one position toward "A". Repeat steps 5–9. (Position "P" will provide the slowest speed for backlapping. Position "A" will provide the fastest speed for backlapping. New motors will generally backlap at position "P", but with time, the set point may need to be moved closer to "A" to account for motor wear.)
10. To make an adjustment to the cutting units while backlapping, turn the reels OFF by moving the Lower Mow/Raise lever rearward; move the Enable/Disable switch to Disable and turn the engine OFF. After adjustments have been completed, repeat steps 5–9.
11. Repeat this procedure for all cutting units to be backlapped.
12. When backlap operation has been completed, return the backlap switch to OFF, lower the seat and tighten both locking bolts securely, and wash all lapping compound off the cutting units. Adjust cutting unit reel-to-bedknife as needed.

IMPORTANT: If the backlap switch is not returned to OFF position after backlapping, the cutting units will not raise or function properly.

IMPORTANT: If the cutting units are removed for backlapping (such as when bedknives are changed) the reel speed sensors must be removed from the left front and the left rear cutting units. Before backlapping, install and torque a 9.5 mm (3/8") capscrew in the left end of the reel shaft with which to drive the reel when backlapping. **DO NOT attempt to use the capscrew which attaches the magnet to drive the reel for backlapping, this cap-**

screw must be torqued to a maximum of 5 ft-lbs. to avoid damage to the magnet.

PREPARATION FOR SEASONAL STORAGE

Traction Unit

1. Thoroughly clean the traction unit, cutting units and the engine.
2. Check the tire pressure. Inflate all traction unit tires to 103–138 kPA (15–20 psi).
3. Check all fasteners for looseness; tighten as necessary.
4. Grease or oil all grease fittings and pivot points. Wipe up any excess lubricant.
5. Lightly sand and use touch-up paint on painted areas that are scratched, chipped, or rusted. Repair any dents in the metal body.
6. Service the battery and cables as follows:
 - a. Remove the battery terminals from the battery posts.
 - b. Clean the battery, terminals, and posts with a wire brush and baking soda solution.
 - c. Coat the cable terminals and battery posts with Grafo 112X skin-over grease (Toro Part No. 50547) or petroleum jelly to prevent corrosion.
 - d. Slowly recharge the battery every 60 days for 24 hours to prevent lead sulfation of the battery.

Engine

1. Drain the engine oil from the oil pan and replace the drain plug.
2. Remove and discard the oil filter. Install a new oil filter.

3. Refill the oil pan with 3.7 l (3.9 quarts) of SAE10W30 motor oil.
4. Start the engine and run at idle speed for approximately two minutes.
5. Stop the engine.
6. Thoroughly drain all fuel from the fuel tank, lines and the fuel filter/water separator assembly.
7. Flush the fuel tank with fresh, clean diesel fuel.
8. Resecure all fuel system fittings.
9. Thoroughly clean and service the air cleaner assembly.
10. Seal the air cleaner inlet and the exhaust outlet with weatherproof tape.
11. Check anti-freeze protection and add as needed for expected minimum temperature in your area.

IDENTIFICATION AND ORDERING

MODEL AND SERIAL NUMBER

The model and serial number is on a plate that is mounted on the left side of footrest. Use model and serial number in all correspondence and when ordering parts.

To order replacement parts from an authorized TORO Distributor, supply the following information:

1. Model and serial numbers of the machine.
2. Part number, description and quantity of parts desired.

Note: If using a parts catalog, do not order by reference number; use the part number instead..

