

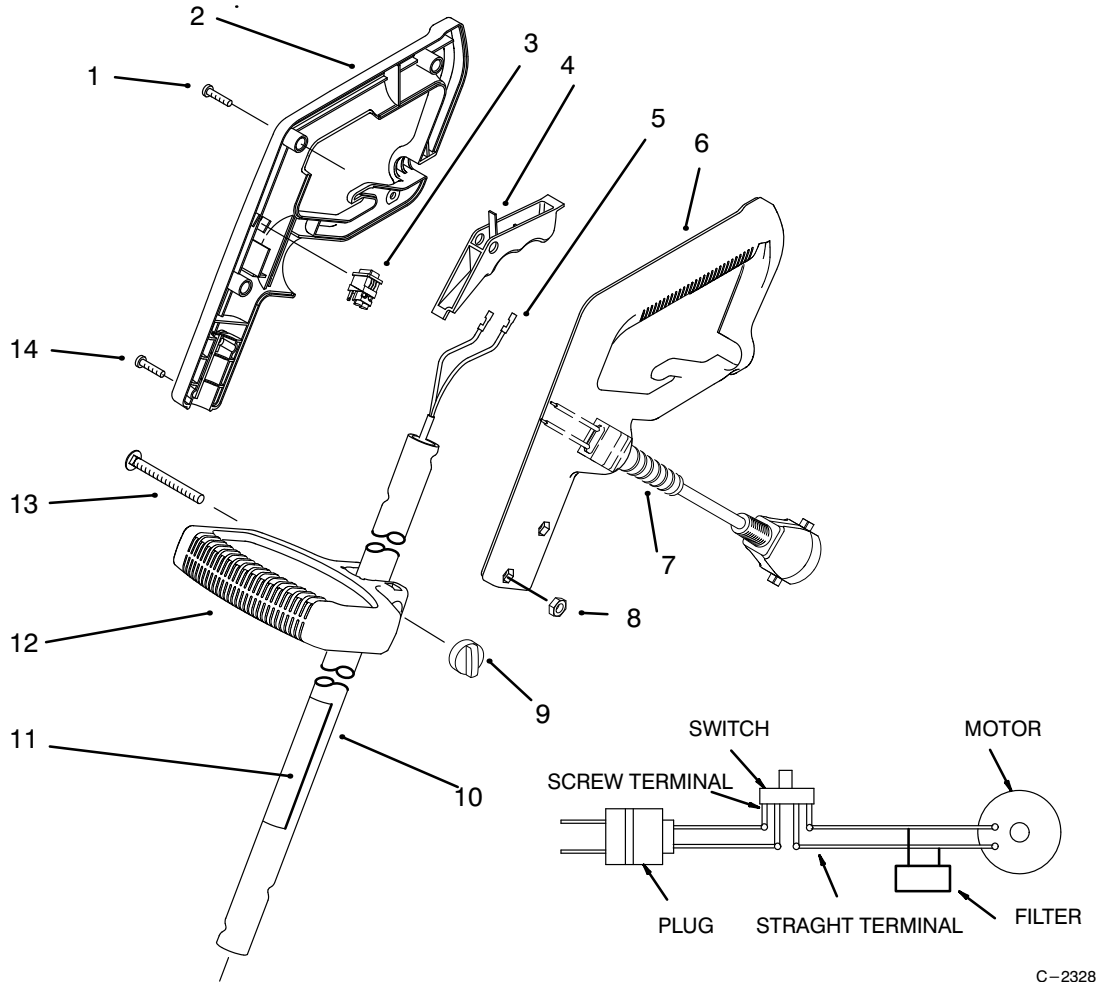

MODEL NO. 51449-590001 & UP

PARTS
CATALOG

35CM ELECTRIC TRIMMER



C-2328

HANDLE ASSEMBLY

Ref. No.	Part No.	Description	No. Used
1	32104-121	Screw - Pan Hd Tapping	4
2	73-8151	Grip - Hand R.H.	1
3	73-9950	Switch	1
4	73-8170	Trigger	1
5	93-4459	Harness - Wire	1
6	73-8161	Grip - Hand L.H.	1
7	93-0556	Cord - Power	1
8	3217-44	Nut - Lock	2

Ref. No.	Part No.	Description	No. Used
9	64-6660	Knob	1
10	93-4485	Tube Assembly (Incl. Ref. #11)	1
11		Decal - Safety	1
12	73-8310	Handle - Mid	1
13	3229-32	Screw - Carriage	1
14	3250-52	Screw - Pan Hd.	2

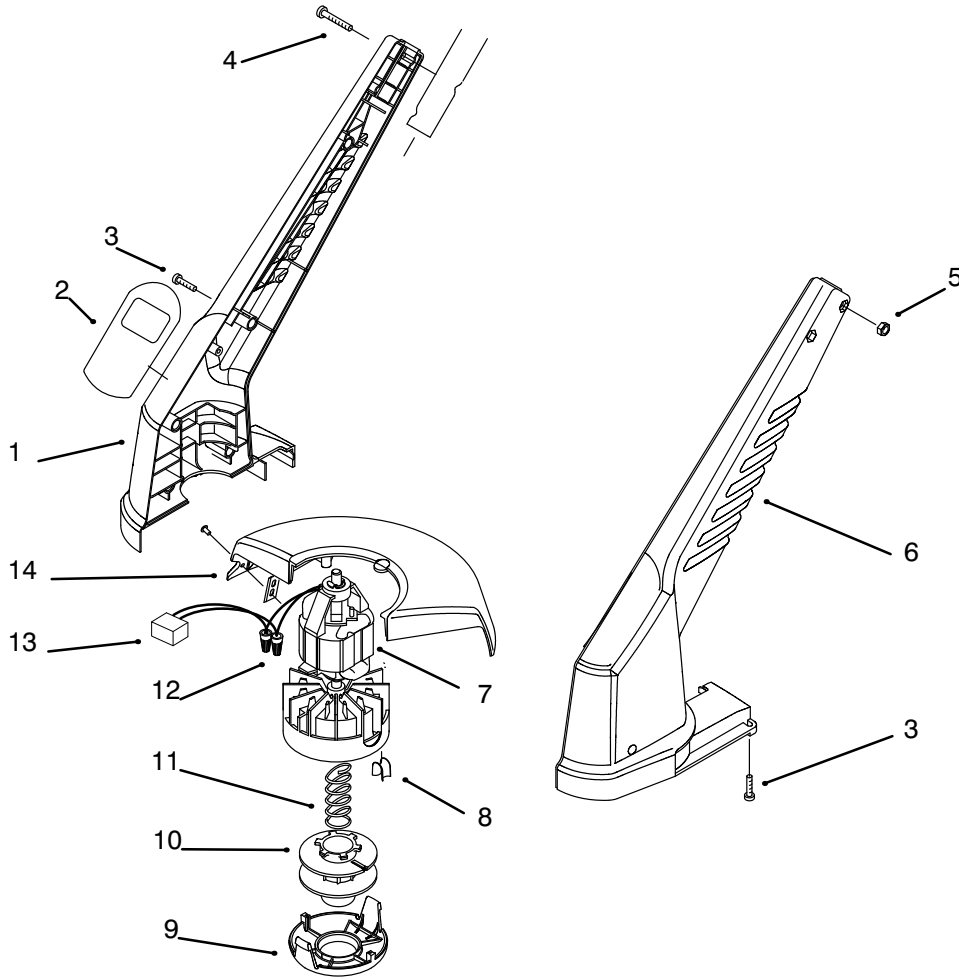

C-2329

MOTOR & HOUSING ASSEMBLY

Ref. No.	Part No.	Description	No. Used
1	73-9970	Housing R.H.	1
2	94-4455	Decal - 35CM Trimmer	1
3	32104-121	Screw - Pan Hd. Tapping	7
4	3250-52	Screw - Pan Hd.	2
5	3217-44	Nut - Hex	2
6	73-9980	Housing L.H.	1
7	93-8713	Motor - Trimmer (Incl. Ref. #8)	1
8	73-8210	Eyelet	1

Ref. No.	Part No.	Description	No. Used
9	73-8200	Cap	1
10	73-8190	Spool	1
11	73-8220	Spring	1
12	73-6570	Connector - Wire Nut	2
13	73-9960	Fliter	1
14	73-9092	Shield	1
*	93-4466	Spool & Line Assembly (Incl. Ref. #10)	1
*	88176	Spool & Line Assembly	1

*Not Illustrated