



Wheel Horse[®]

**44" Snowthrower
for Garden Tractors**

79361—200000001 & Up

Operator's Manual

Introduction

We want you to be completely satisfied with your new product, so feel free to contact your local Authorized Service Dealer for help with service, genuine replacement parts, or other information you may require.

Whenever you contact your Authorized Service Dealer or the factory, always know the model and serial numbers of your product. These numbers will help the Service Dealer or Service Representative provide exact information about your specific product. You will find the model and serial number plate located in a unique place on the product as shown below.

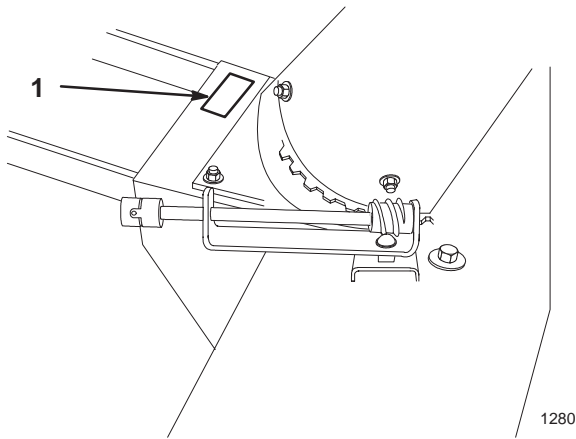

1. Model and Serial Number Plate

For your convenience, write the product model and serial numbers in the space below.

Model No: _____
Serial No. _____

The warning system in this manual identifies potential hazards and has special safety messages that help you and others avoid personal injury, even death. DANGER, WARNING and CAUTION are signal words used to identify the level of hazard. However, regardless of the hazard, be extremely careful.

DANGER signals an extreme hazard that will cause serious injury or death if the recommended precautions are not followed.

WARNING signals a hazard that may cause serious injury or death if the recommended precautions are not followed.

CAUTION signals a hazard that may cause minor or moderate injury if the recommended precautions are not followed.

Two other words are also used to highlight information. “Important” calls attention to special mechanical information and “Note” emphasizes general information worthy of special attention.

The left and right side of the machine is determined by sitting on the seat in the normal operator’s position.

Contents

	Page		Page
General Snowthrower Safety	2	Adjusting Dial-A-Height	20
Toro Snowthrower Safety	3	Adjusting Discharge Chute	20
Safety and Instruction Decals	5	Tips for Throwing Snow	21
Assembly	6	Maintenance	22
Loose Parts	6	Service Interval Chart	23
Assemble Snowthrower	8	Greasing and Lubrication	23
Install Snowthrower to Tractor	10	Adjusting Skids	23
Removing the Snowthrower	14	Replacing Scraper Blade	24
Operation	18	Adjusting Drive Chain Tension	25
Operating the Power Take Off (PTO)	18	Replace Drive Belt	25
Attachment Lift Lever	19	Storage	26
Attachment Power Lift	19	Troubleshooting	27

Safety

Improper use or maintenance by the operator or owner can result in injury. To reduce the potential for injury, comply with the safety instructions in the traction unit operator's manual and always pay attention to the safety alert  symbol, which means CAUTION, WARNING, or DANGER—"personal safety instruction." Failure to comply with the instruction may result in personal injury or death.

DANGER

POTENTIAL HAZARD

- The rotating impeller/auger can cut off fingers, hands, or other body parts.

WHAT CAN HAPPEN

- Contact with the rotating impeller/auger can cause severe injury or death.

HOW TO AVOID THE HAZARD

- Stay away from the discharge and auger openings while operating the snowthrower.
- Keep your hands, feet, and any other part of your body or clothing away from concealed, moving, or rotating parts.
- Use a stick, not your hand, to remove obstructions from the discharge chute or auger housing.
- Before adjusting, cleaning, repairing, and inspecting the snowthrower and before unclogging the discharge chute, stop the engine and wait for all moving parts to stop. Remove the key.

WARNING

POTENTIAL HAZARD

- Stones and other foreign objects may be picked up and thrown by the rotor blades.

WHAT CAN HAPPEN

- Thrown objects can cause serious personal injury to operator or bystanders.

HOW TO AVOID THE HAZARD

- Keep the work area free of all objects that could be thrown by the rotor blades.
- Keep all children and pets away from area of operation.

General Snowthrower Safety

The following instructions have been adapted from the ANSI/OPEI and ISO standards.

Preparation

- Thoroughly inspect the area where the equipment is to be used and remove all doormats, sleds, boards, wires, and other foreign objects.
- Do not operate the equipment without wearing adequate winter outer garments. Wear footwear that will improve footing on slippery surfaces.
- Adjust the auger housing height to clear gravel or crushed rock surface.
- Never attempt to make any adjustments while the engine is running, except when specifically recommended by Toro.

- Let engine and machine adjust to outdoor temperatures before starting to clear snow.
- The operation of any powered machine can result in foreign objects being thrown into the eyes. Always wear safety glasses or eye shields during operation or while performing an adjustment or repair.

Operation

- Do not put hands or feet near or under rotating parts. Keep clear of the discharge opening at all times.
- Exercise extreme caution when operating on or crossing gravel drives, walks, or roads. Stay alert for hidden hazards or traffic. Do not carry passengers.
- After striking a foreign object, stop the engine, remove the wire(s) from the spark plug(s), thoroughly inspect the snowthrower for any damage, and repair the damage before restarting and operating the snowthrower.
- If the unit should start to vibrate abnormally, stop the engine and check immediately for the cause. Vibration is generally a warning of trouble.
- Stop the engine whenever you leave the operating position, before unclogging the auger/impeller housing or discharge chute, and when making any repairs, adjustments, or inspections.
- When cleaning, repairing, or inspecting, make certain the auger/impeller and all moving parts have stopped. Disconnect the spark plug wire(s) and keep the wire away from the plug to prevent someone from accidentally starting the engine.
- Do not clear snow across the face of slopes. Exercise extreme caution when changing direction on slopes. Do not attempt to clear steep slopes.

- Never operate the snowthrower without proper guards, plates, or other safety protective devices in place.
- Never operate the snow thrower near glass enclosures, automobiles, window wells, drop-offs, and the like without proper adjustment of the snow discharge angle. Keep children and pets away.
- Do not overload the machine capacity by attempting to clear snow at too fast a rate.
- Never operate the machine at high transport speeds on slippery surfaces. Look behind and use care when moving in reverse.
- Never direct discharge at bystanders or allow anyone in front of the unit.
- Disengage power to the auger/impeller when the snowthrower is transported or not in use.
- Never operate the snowthrower without good visibility or light.

Maintenance and Storage

- Check fasteners at frequent intervals for proper tightness to be sure the equipment is in safe working condition.
- Always refer to the operator's manual for important details if the snowthrower is to be stored for an extended period.
- Maintain or replace safety and instruction labels, as necessary.
- Run the machine a few minutes after throwing snow to prevent freeze-up of the auger/impeller.

Toro Snowthrower Safety

The following list contains safety information specific to Toro products or other safety information that you must know that is not included in the ANSI or ISO standards.

- **The rotating auger/impeller or rotor blades can cut off or injure fingers or hands.** Stay in the operator's position and away from the discharge opening while operating the snowthrower. **Keep your face hands, feet, and any other part of your body or clothing away from concealed, moving, or rotating parts.**
- Before adjusting, cleaning, repairing, and inspecting the snowthrower, and before unclogging the discharge chute, **stop the engine, remove the key, and wait for all moving parts to stop.** Also, pull the wire(s) off of the spark plug(s) and keep it away from the plug(s) to prevent someone from accidentally starting the engine.
- Use a stick, **not your hands** to remove obstructions from the discharge chute.
- **Before** leaving the operator's position, stop the engine, remove the key, and wait for all moving parts to stop.
- Do not wear loose fitting clothing that could possibly get caught in moving parts.
- If a shield, safety device, or decal is damaged, illegible, or lost, repair or replace it before beginning operation. Also, tighten any loose fasteners.
- **Do not** use the snowthrower on a roof.
- Perform only those maintenance instructions described in this manual. Before performing any maintenance, service, or adjustment, stop the engine, remove the key and pull the wire(s) from the spark plug(s), keeping it away from the plug(s) to prevent someone from accidentally starting the engine. If major repairs are ever needed, contact your Authorized Toro Service Dealer.
- To ensure the best performance and safety, purchase only genuine Toro replacement parts and accessories to keep the Toro all Toro. **Do not use "Will Fit" replacement parts and accessories as they could cause a safety hazard.**

Safety and Instruction Decals



Safety decals and instructions are easily visible to the operator and are located near any area of potential danger. Replace any decal that is damaged or lost.

**ON BACK OF HOUSING
RIGHT SIDE
(Part No. 92-8652)**

⚠ WARNING





- ROTATING AUGER AND IMPELLER CAN CUT OR REMOVE BODY PARTS AND THROW OBJECTS.
- SHUT OFF ENGINE TO ADJUST, SERVICE, UNCLOG OR REMOVE DEBRIS.
- NEVER DISCHARGE AT OTHERS.
- READ OPERATOR'S MANUAL FOR OPERATING AND SAFETY INSTRUCTIONS.
- KEEP SAFETY DEVICES (SUCH AS GUARDS AND SWITCHES) IN PLACE AND WORKING.

63-8652

**ON BACK OF CHUTE
LEFT AND RIGHT SIDE (2)
(Part No. 94-8079)**

⚠ DANGER



- CONTACT WITH MOVING PARTS INSIDE CHUTE WILL CAUSE SERIOUS INJURY.
- SHUT OFF ENGINE BEFORE UNCLOGGING DISCHARGE CHUTE.
- NEVER PUT HAND IN CHUTE.

94-8079

**ON BACK OF HOUSING
LEFT AND RIGHT SIDE (2)
(Part No. 63-2380)**

⚠ DANGER



AVOID INJURY FROM ROTATING AUGER. KEEP HANDS, FEET AND CLOTHING AWAY. 63-2380

Assembly

Loose Parts

Note: Use the chart below to identify parts used for assembly.

DESCRIPTION	QTY.	USE
Housing	1	Install frame and pulley
Frame	1	
Bolt 3/8–16 x 1”	6	
Locknut 3/8”	6	
Spring	1	
Drive chain	1	
Chain cover	1	
Bolt 1/4–20 x 1/2”	2	
Rotor assembly	1	Install rotator and discharge chute assembly
Carriage bolt 5/16–18 x 1”	1	
Discharge chute-upper section	1	
Discharge chute-lower section	1	
Discharge cover	1	
Carriage bolt 5/16–18 x 5/8”	2	
Carriage bolt 5/16–18 x 3/4”	3	
Washer 5/16”	5	
Locknut 5/16”	6	
Belt guard bracket	1	Install belt guard and anti-sway brackets
Bolt 3/8–16 x 2”	2	
Locknut 3/8”	2	
Anti-sway bracket	1	
Clevis pin	1	
Belt cover	1	
Washer 3/8”	2	
Hairpin cotter	3	

DESCRIPTION	QTY.	USE
Snowthrower assembly	1	Mount snowthrower to tractor
Lift link	1	
Lift rod	1	
Lift assist spring	1	
Adjustable link	1	
Clevis pin	1	
Washer 9/32"	4	
Hairpin cotter	8	
Lift spring	1	
Retainers	2	
Belt	1	
Crank handle	1	
Handle support	1	
Clevis pin-locking	1	

Assemble Snowthrower

1. Place drive chain behind, not on, gearbox drive sprocket (Fig. 1).

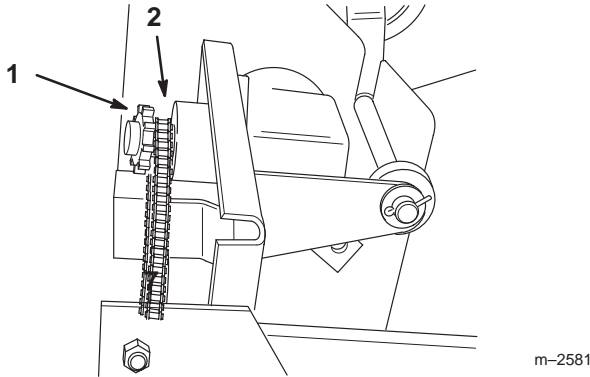

Figure 1

1. Drive sprocket
2. Drive chain

2. Remove cross bar from frame, secured by (2) bolts and lock washers (Fig. 2). Slide frame into housing and secure with cross bar, bolts and lock washers, previously removed and (6) 3/8 x 1" bolts (heads to the inside) and (4) 3/8" locknuts (Fig. 2).

3. Hook long end of spring between frame bolt and idler pulley bellcrank (Fig. 2).

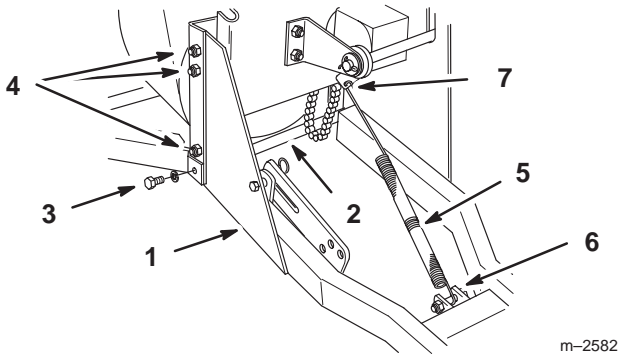

Figure 2

1. Frame
2. Cross bar
3. Bolt and lock washer
4. Bolt 3/8 x 1" and Locknut 3/8"
5. Spring
6. Frame bolt
7. Bellcrank

4. Place drive chain on gearbox and large sprockets (Fig. 3).

IMPORTANT: Check that sprockets are in line with each other. If not, loosen set screws and align.

5. Adjust chain tension block so chain deflects 3/8" to 5/8" between sprockets (Fig. 3).

IMPORTANT: Do not overtighten chain or excessive wear will occur.

6. Install chain cover with (2) 1/4 x 1/2" bolts (Fig. 3).

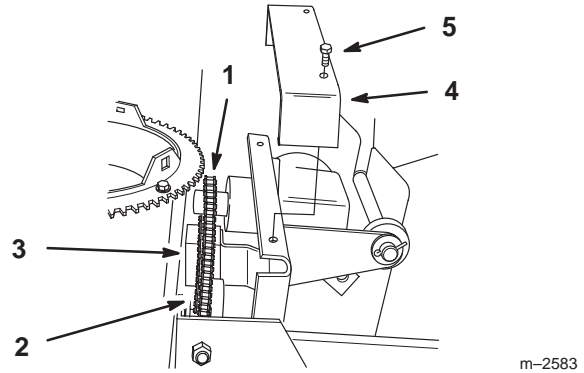

Figure 3

1. Chain
2. Large sprocket
3. Tension block
4. Chain cover
5. Bolt 1/4 x 1/2"

7. Install discharge chute rotator assembly into slot in housing with 5/16 x 1" carriage bolt (head to top) and 5/16" locknut (Fig. 4).
8. Adjust rotator assembly so that worm gear is at right angle with chute, the teeth mesh fully and the chute turns freely, tighten locknut securely.

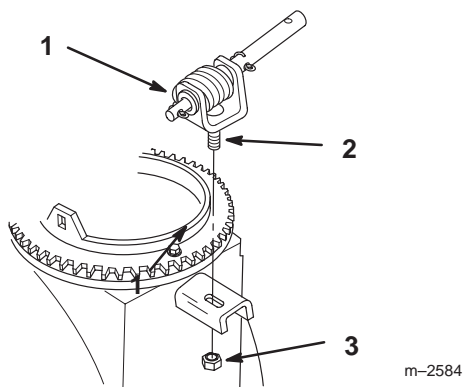

Figure 4

- | | |
|----------------------------|------------------|
| 1. Rotator assembly | 3. Locknut 5/16" |
| 2. Carriage bolt 5/16 x 1" | |

9. Assemble upper discharge chute section outside and on top of lower section with (2) 5/16 x 5/8" carriage bolts (heads on inside), (2) 5/16" washers and (2) 5/16" locknuts (Fig. 5).

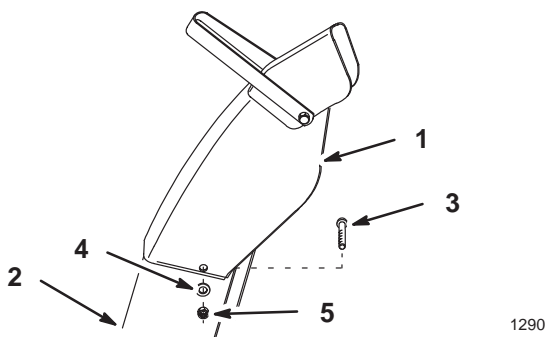

Figure 5

- | | |
|------------------------------|------------------|
| 1. Upper section | 4. Washer 5/16" |
| 2. Lower section | 5. Locknut 5/16" |
| 3. Carriage bolt 5/16 x 5/8" | |

10. Install discharge chute assembly and cover onto housing with (3) 5/16 x 3/4" carriage bolts (heads to inside), (3) 5/16" washers and (3) 5/16" locknuts (Fig. 6).

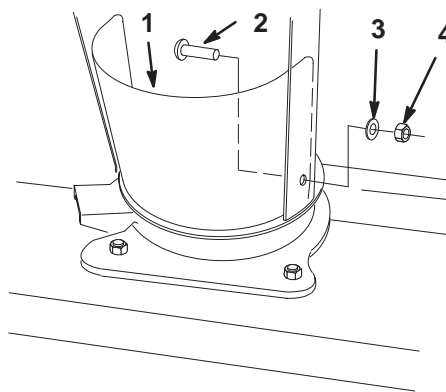

Figure 6

- | | |
|------------------------------|------------------|
| 1. Discharge chute cover | 3. Washer 5/16" |
| 2. Carriage bolt 5/16 x 3/4" | 4. Locknut 5/16" |

2241

Install Snowthrower to Tractor

DANGER

POTENTIAL HAZARD

- When snowthrower is attached to the tractor, without additional weight, the tractor may become unstable.

WHAT CAN HAPPEN

- Loss of traction and stability may cause loss of tractor control.

HOW TO AVOID THE HAZARD

- NEVER operate tractor, equipped with snowthrower, unless 100lb rear wheel weights are installed.

1. Park the machine on a level surface, disengage the power take off (PTO), set the parking brake, and turn the ignition key to "OFF" to stop the engine. Remove the key.
2. Remove the belt cover; refer to tractor Operator's Manual.
3. Install belt guard bracket to tractor frame with (2) 3/8 x 2" bolts and 3/8" locknuts (Fig. 7).

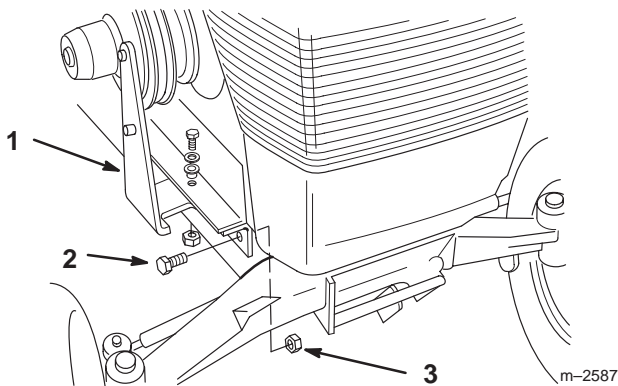

Figure 7

- | | |
|-----------------------|-----------------|
| 1. Belt guard bracket | 3. Locknut 3/8" |
| 2. Bolt 3/8 x 2" | |

4. Slide anti-sway bracket into guide slot in the front of the belt guard bracket and secure to frame with clevis pin and hairpin cotter (Fig. 8).

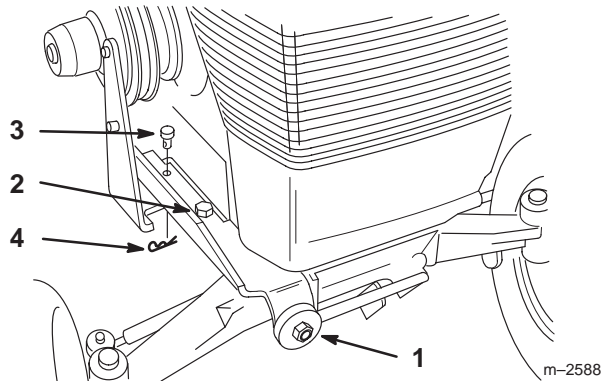

Figure 8

- | | |
|----------------------|-------------------|
| 1. Anti-sway bracket | 3. Clevis pin |
| 2. Guide | 4. Hairpin cotter |

5. Position tractor over rear of snowthrower frame. Open mid-mount hitch and lift frame rod into hitch. Close and lock hitch (Fig. 9).

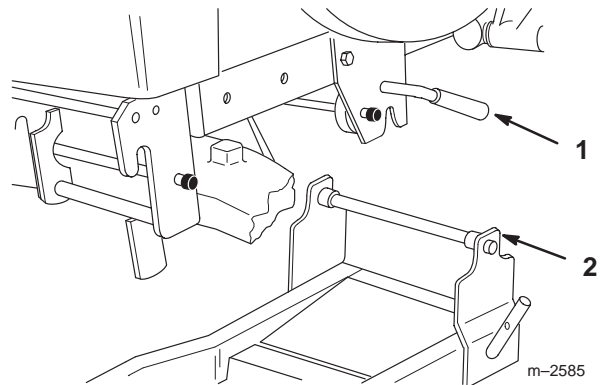

Figure 9

- | | |
|--------------------|--------------|
| 1. Mid-mount hitch | 2. Frame rod |
|--------------------|--------------|

6. Open front hitch on tractor and install lift link (Fig. 10).
7. Place lift rod into lower arm of lift link and secure with washer and hairpin cotter (Fig. 10).

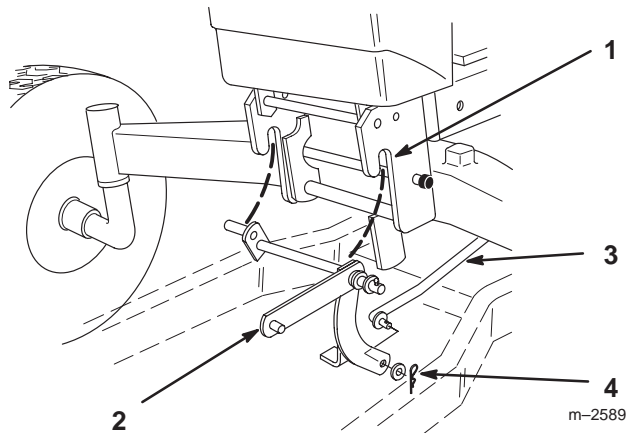

Figure 10

- | | |
|----------------|------------------------------|
| 1. Front hitch | 3. Lift rod |
| 2. Lift link | 4. Washer and hairpin cotter |

11. Install adjustment link between snowthrower frame, with clevis pin, and lift link arm. Secure with washers and hairpin cottes (Fig. 12).
12. Select upper hole in adjustment link depending on surface conditions; refer to Operation Section.

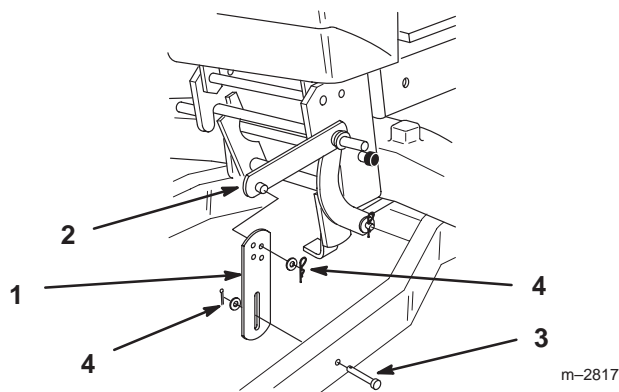

Figure 12

- | | |
|--------------------|------------------------------|
| 1. Adjustable link | 3. Clevis pin |
| 2. Lift link arm | 4. Washer and hairpin cotter |

8. Turn Dial-A-Height knob counterclockwise and lower attachment lift all the way down.
9. Place rear of lift rod into tractor lift arm and secure with washer and hairpin cotter (Fig. 11).
10. Hook lift assist spring between snowthrower frame rod and tab on lift rod (Fig. 11).

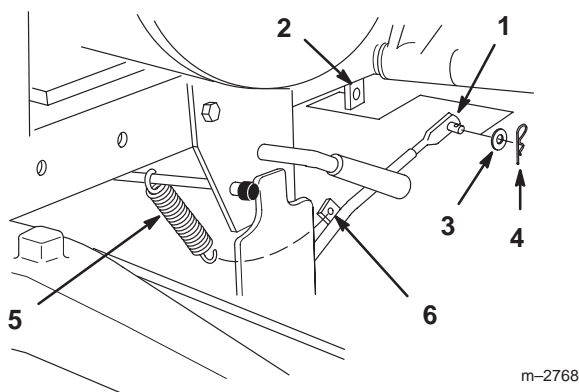

Figure 11

- | | |
|---------------------|-----------------------|
| 1. Lift rod | 4. Hairpin cotter |
| 2. Tractor lift arm | 5. Lift assist spring |
| 3. Washer | 6. Tab |

13. Raise tractor attachment lift to the transport position and place a block under snowthrower housing. Turn the Dial-A-Height knob counterclockwise, all the way, and lower the attachment to the mounting position; refer to Operation, Lowering Attachments.
14. Raise arm of lift link into the relaxed position (Fig. 13).
15. Install lift spring between frame and lift link with retainers, inside body of spring, and secure with hairpin cotters (Fig. 13).
16. Push arm of lift link down into locked position (Fig. 13).

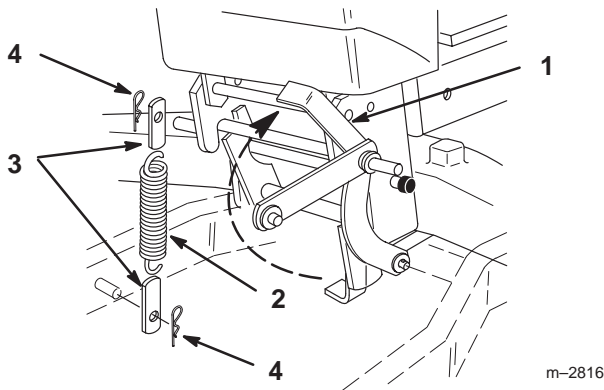

Figure 13

- | | |
|------------------|-------------------|
| 1. Lift link arm | 3. Retainer |
| 2. Lift spring | 4. Hairpin cotter |

17. Remove the two wing nuts and belt cover from the tractor (Fig. 14).

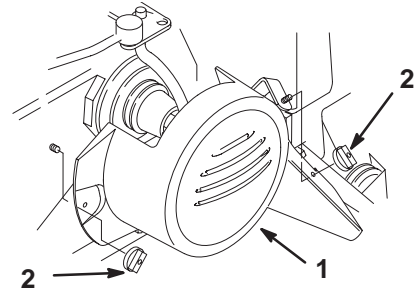

Figure 14

- | | |
|---------------|-------------|
| 5. Belt cover | 6. Wing nut |
|---------------|-------------|

18. Remove hairpin cotters from trunnion and bottom of yoke (Fig. 15).
19. Unlatch and remove locking clevis pin that secures yoke assembly to clutch shaft. Pivot yoke out and forward to remove from clutch shaft and engagement plate (Fig. 15).
20. Place snowthrower belt in outer pulley groove (Fig. 15).
21. Assemble yoke and engagement plate and attach locking clevis pin, trunnion and hairpin cotters to secure (Fig. 15).

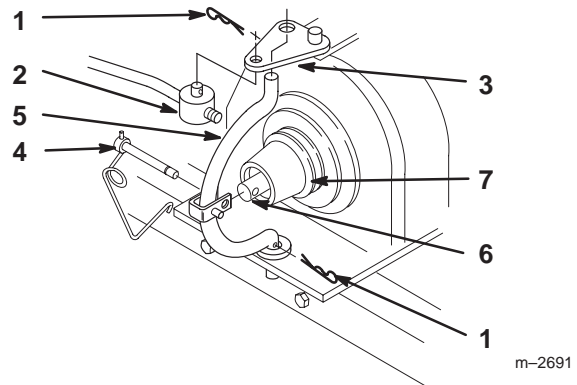

Figure 15

- | | |
|-----------------------|-----------------|
| 1. Hairpin cotter | 5. Yoke |
| 2. Trunnion | 6. Clutch shaft |
| 3. Engagement plate | 7. Outer groove |
| 4. Locking clevis pin | |

22. Route belt around idler pulleys (Fig. 16).
23. Rotate idler bracket to stretch spring and slip belt over snowthrower pulley (Fig. 16),

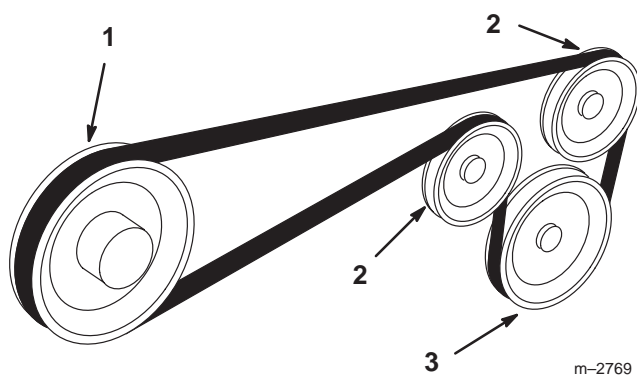

Figure 16

- | | |
|---|-----------------------|
| 1. Outer groove of (PTO) power take off | 2. Idler pulley |
| | 3. Snowthrower pulley |

24. Install belt cover to belt guard bracket and secure with washers and hairpin cotters (Fig. 17),

Note: Use inner holes for single cylinder engines and outer holes for twin cylinder engines.

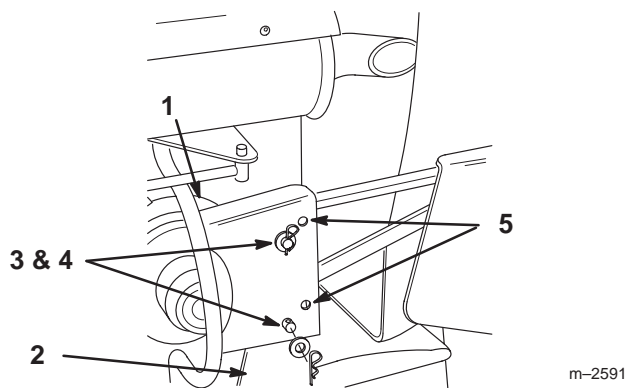

Figure 17

- | | |
|------------------------------|--------------------------|
| 1. Belt cover | 4. Single cylinder holes |
| 2. Belt guard bracket | 5. Twin cylinder holes |
| 3. Washer and hairpin cotter | |

25. Slide handle support over pin on frame and secure with locking clevis pin (Fig. 18).

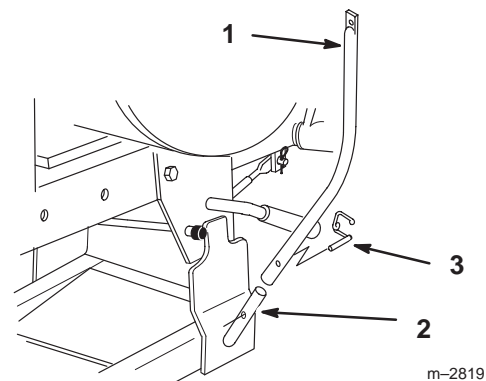

Figure 18

- | | |
|-------------------|-----------------------|
| 1. Handle support | 3. Locking clevis pin |
| 2. Pin | |

26. Slide crank handle through hole in support and secure handle to U-Joint with hairpin cotter (Fig. 19).

Note: Adjust rotor assembly if necessary so handle clears tractor hood, teeth mesh fully and chute turns freely.

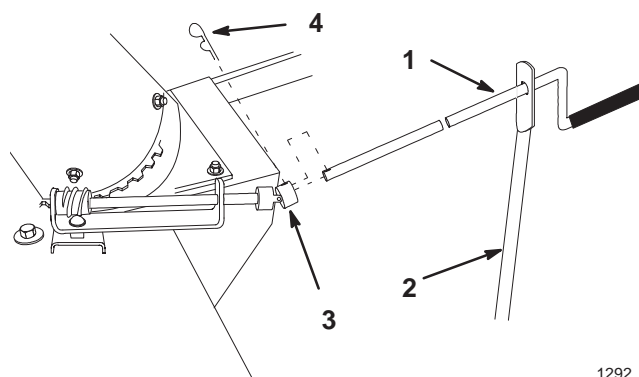

Figure 19

- | | |
|-----------------|-------------------|
| 1. Crank handle | 3. U-joint |
| 2. Support | 4. Hairpin cotter |

Removing the Snowthrower

Note: Save all hardware, washers and hairpin cotters for reuse when installing snowthrower.

1. Park the machine on a level surface, disengage the power take off (PTO), set the parking brake, and turn the ignition key to "OFF" to stop the engine. Remove the key.
2. Remove hairpin cotter at U-joint and slide crank handle out of support (Fig. 20).

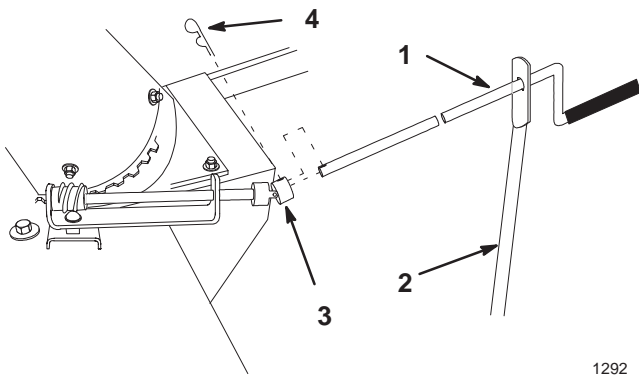

Figure 20

- | | |
|-----------------|-------------------|
| 1. Crank handle | 3. U-joint |
| 2. Support | 4. Hairpin cotter |

1292

3. Unlatch and remove locking clevis pin and handle support from frame (Fig. 21).

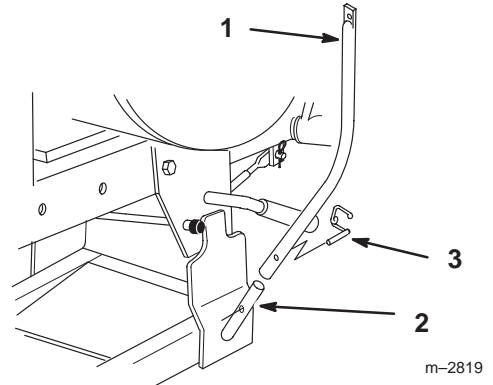

Figure 21

- | | |
|-------------------|-----------------------|
| 1. Handle support | 3. Locking clevis pin |
| 2. Pin | |

m-2819

4. Remove hairpin cotters, washers and belt cover from belt guard bracket (Fig. 22),

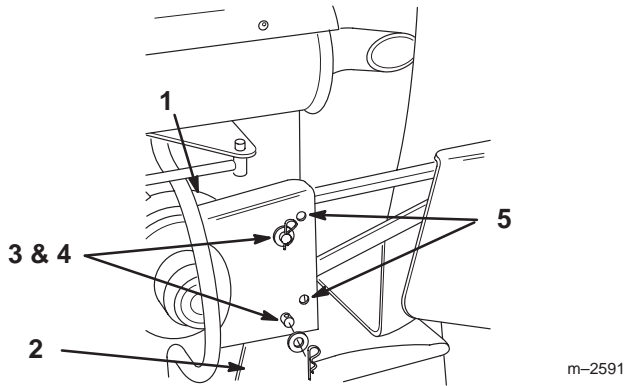

Figure 22

- | | |
|------------------------------|--------------------------|
| 1. Belt cover | 4. Single cylinder holes |
| 2. Belt guard bracket | 5. Twin cylinder holes |
| 3. Washer and hairpin cotter | |

m-2591

5. Rotate idler bracket to relax belt tension and slip belt off snowthrower pulley (Fig. 23),

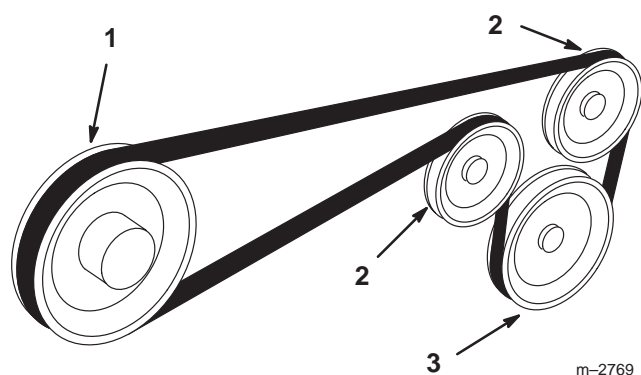

Figure 23

- | | |
|--|-----------------------|
| 1. Outer groove of (PTO)
power take off | 3. Belt guide |
| 2. Idler pulley | 4. Snowthrower pulley |

6. Remove hairpin cotters from trunnion and bottom of yoke (Fig. 24).
7. Unlatch and remove locking clevis pin that secures yoke assembly to clutch shaft. Pivot yoke out and forward to remove from clutch shaft and engagement plate (Fig. 24).
8. Remove snowthrower belt from pulley (Fig. 24).
9. Assemble yoke and engagement plate and attach locking clevis pin, trunnion and hairpin cotters to secure (Fig. 24).
10. Install the belt cover; refer to tractor Operator's Manual.

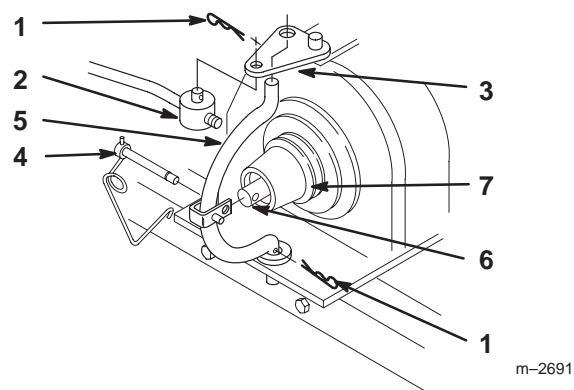

Figure 24

- | | |
|-----------------------|-----------------|
| 1. Hairpin cotter | 5. Yoke |
| 2. Trunnion | 6. Clutch shaft |
| 3. Engagement plate | 7. Pulley |
| 4. Locking clevis pin | |

11. Raise attachment lift to the transport position and place a block under snowthrower housing. Turn the Dial-A-Height knob counterclockwise, all the way, and lower the attachment to the mounting position; refer to Operation, Lowering Attachments.
12. Raise arm of lift link into the relaxed position (Fig. 25).
13. Remove lift spring from between frame and lift link (Fig. 25).

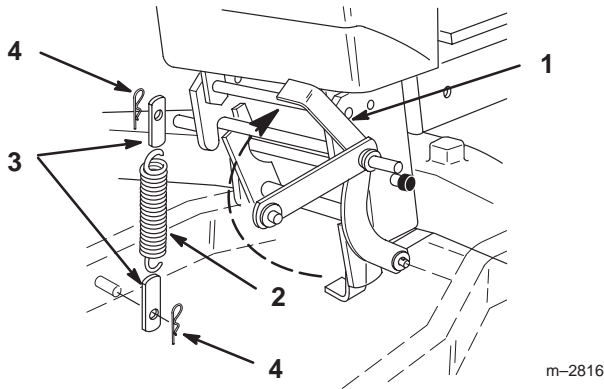

Figure 25

- | | |
|------------------|-------------------|
| 1. Lift link arm | 3. Retainer |
| 2. Lift spring | 4. Hairpin cotter |

14. Remove hairpin cotter, washer and adjustment link from lift link arm (Fig. 26).

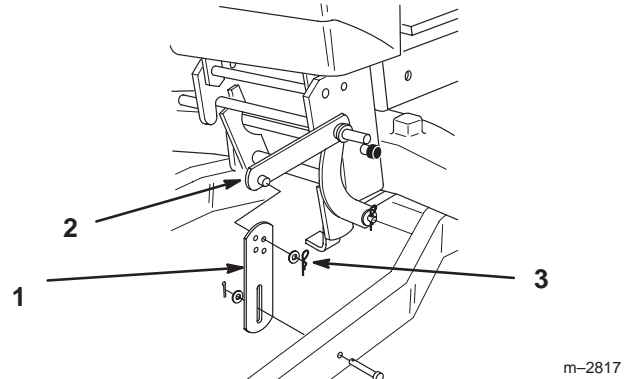

Figure 26

- | | |
|--------------------|------------------------------|
| 1. Adjustable link | 3. Washer and hairpin cotter |
| 2. Lift link arm | |

15. Remove hairpin cotter, washer and lift rod from lower arm of lift link (Fig. 27).

16. Open front hitch on tractor and remove lift link (Fig. 27).

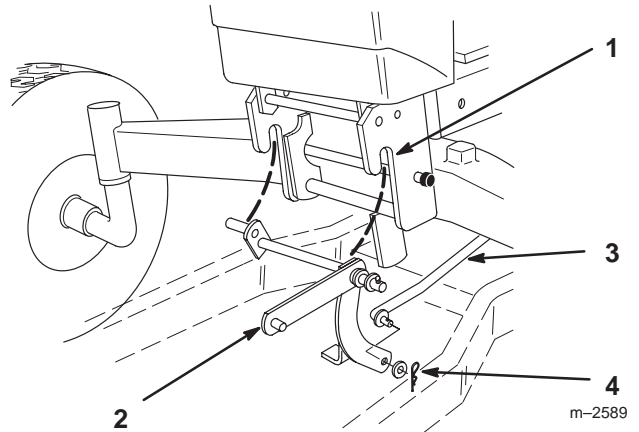

Figure 27

- | | |
|----------------|------------------------------|
| 1. Front hitch | 3. Lift rod |
| 2. Lift link | 4. Washer and hairpin cotter |

17. Turn Dial-A-Height knob counterclockwise and lower attachment lift all the way down.
18. Unhook lift assist spring between snowthrower frame rod and tab on lift rod (Fig. 28).
19. Remove hairpin cotter, washer and lift rod from tractor lift arm (Fig. 28).

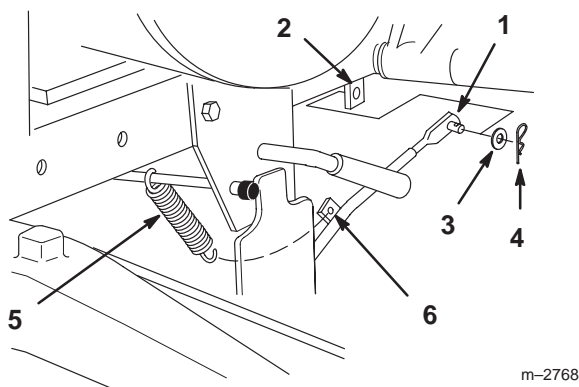

Figure 28

- | | |
|---------------------|-----------------------|
| 1. Lift rod | 4. Hairpin cotter |
| 2. Tractor lift arm | 5. Lift assist spring |
| 3. Washer | 6. Tab |

Operation

DANGER

POTENTIAL HAZARD

- When snowthrower is attached to the tractor, without additional weight, the tractor may become unstable.

WHAT CAN HAPPEN

- Loss of traction and stability may cause loss of tractor control.

HOW TO AVOID THE HAZARD

- NEVER operate tractor, equipped with snowthrower, unless 100lb rear wheel weights are installed.

DANGER

POTENTIAL HAZARD

- Rotating auger can cut off fingers, hands or other body parts and throw objects.

WHAT CAN HAPPEN

- Contact with rotating auger and thrown debris can cause severe injury or death.

HOW TO AVOID THE HAZARD

- Stay away from the discharge and auger openings while operating the snowthrower.
- Keep your hands, feet, and any other part of your body or clothing away from concealed, moving or rotating parts.
- Use a stick, not your hand, to remove obstructions from discharge chute or auger housing.
- Before adjusting, cleaning, repairing and inspecting the snowthrower and before unclogging the discharge chute, shut off the engine and wait for all moving parts to stop. Move the power take off (PTO) to “OFF” and rotate the ignition key to “OFF.” Remove the key.

Operating the Power Take Off (PTO)

The power take off (PTO) engages and disengages power to the electric clutch.

While the ignition key is in the “RUN” or “LIGHTS” positions and the power take off (PTO) is engaged “ON”, the PTO light, in the Indicator Module, will be “ON”. When this light is “ON” it is a reminder; the starter will not crank and to turn off the PTO before getting off.

Engaging the Power Take Off (PTO)

1. Depress the brake and/or clutch pedal(s) to stop the machine.
2. Push the power take off (PTO) to “ON” (Fig. 29).

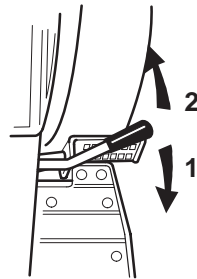

m-2519

Figure 29

1. Off-Disengaged
2. On-Engaged

Disengaging the Power Take Off (PTO)

1. Depress the brake and/or clutch pedal(s) to stop the machine.
2. Pull the power take off (PTO) to “OFF” (Fig.29).

Attachment Lift Lever

The attachment lift lever (Fig. 30) is used to manually raise and lower attachments.

Raising Attachments

1. Depress the clutch and/or brake pedal(s) to stop the machine.
2. Pull attachment lift lever rearward until latch locks. In this position the lift will hold the attachment in the up, or raised position.

Lowering Attachments

1. Depress the clutch and/or brake pedal(s) to stop the machine.
2. Pull attachment lift lever rearward, to release lift pressure, and push the button on top to release the latch. Move lift lever forward to lower attachment.

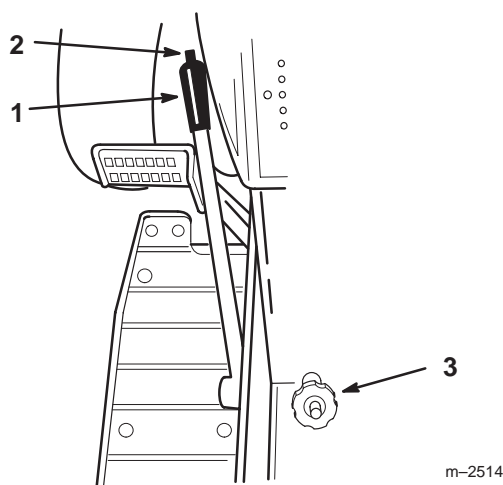

Figure 30

1. Lift lever
2. Button
3. Dial-A-Height

Attachment Power Lift

The attachment power lift (Fig. 31) is used to raise and lower attachments.

Raising Attachments

1. Start the engine, refer to; Starting and Stopping the Engine, in the Tractor Operator's Manual.
2. Pull the lift lever in the "UP" direction to raise the attachment lift (Fig. 31). This will lift and hold the attachment in the up, or raised position.

Lowering Attachments

1. Start the engine, refer to; Starting and Stopping the Engine, in the Tractor Operator's Manual.
2. Push the lift lever in the "DOWN" direction to lower the attachment lift (Fig. 31). This will lower the attachment lift.

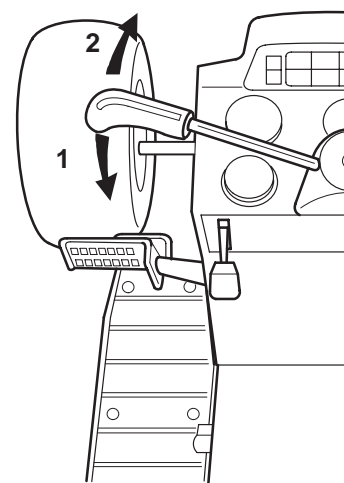

Figure 31

1. Lift lever UP
2. Lift lever DOWN

Adjusting Dial-A-Height

The Dial-A-Height control (Fig. 30) is used to limit the downward travel of the attachment. The Dial-A-Height knob is rotated to change the location of this stop, up or down.

1. Raise the attachment lift: Refer to Raising Attachments. In the raised position the Dial-A-Height knob (Fig. 30) can be rotated to change the stop location. Turn clockwise to raise and counterclockwise to lower the height of the attachment.
2. The Dial-A-Height indicator (Fig. 30) will show the change, high to low, in attachment lift height as adjustment is made.

Adjusting Discharge Chute

DANGER

POTENTIAL HAZARD

- Rotating auger can cut off fingers, hands or other body parts and throw objects.

WHAT CAN HAPPEN

- Contact with rotating auger and thrown debris can cause severe injury or death.

HOW TO AVOID THE HAZARD

- Stay away from the discharge and auger openings while operating the snowthrower.
- Keep your hands, feet, and any other part of your body or clothing away from concealed, moving or rotating parts.
- Use a stick, not your hand, to remove obstructions from discharge chute or auger housing.
- Before adjusting, cleaning, repairing and inspecting the snowthrower and before unclogging the discharge chute, shut off the engine and wait for all moving parts to stop. Move the power take off (PTO) to “OFF” and rotate the ignition key to “OFF.” Remove the key.

The discharge chute can be rotated 180° side to side. The direction is controlled by turning the crank handle (Fig. 32).

The chute deflector, on top of the discharge chute, can be moved up and down to control the height and distance snow is thrown (Fig. 32).

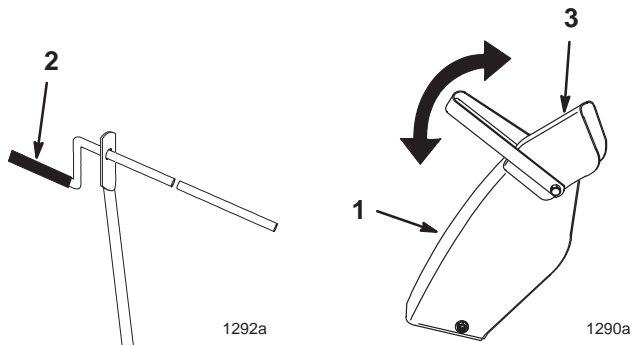

Figure 32

1. Discharge chute
2. Crank handle
3. Chute deflector

Tips for Throwing Snow

Remove snow as soon as possible after it falls. This produces best snow removal results.

Adjust skids to match the type of surface being cleaned; refer to Adjusting Skids.

The snowthrower is designed to clean snow down to the contact surface, but there are times when the front of the snowthrower may tend to ride up. If this happens, reduce forward speed.

Discharge snow downwind whenever possible, and overlap each pass to ensure complete snow removal. If wheels slip, shift into a lower gear to reduce forward speed.

Run snowthrower for a few minutes after clearing snow so moving parts do not freeze. Engage power take off (PTO) to clear any remaining snow from inside housing.

Do not overload snowthrower by clearing snow at too fast a rate. If engine slows down, reduce forward speed.

Always use full throttle (maximum engine speed) when throwing snow.

In wet or slushy conditions, clogging of the discharge chute will be reduced by maintaining maximum engine speed and by not overloading the engine.

In some snow and cold weather conditions, some controls and moving parts may freeze. Therefore, when any control becomes hard to operate, stop the machine and wait for all moving parts to stop; then check all parts for freeze up. **DO NOT USE EXCESSIVE FORCE AND TRY TO OPERATE THE CONTROLS WHEN FROZEN.** Free all controls and moving parts before operating.

Maintenance

Service Interval Chart

Service Operation	Each Use	5 Hours	25 Hours	Storage Service	Fall Service	Notes
Grease—drive shaft bearings			X	X	X	
Oil—drive chain			X	X	X	
Oil—check gear box				X	X	
Belt—check for wear/cracks				X	X	
Chipped Surfaces—paint				X		
Scraper—check for wear				X	X	

CAUTION

POTENTIAL HAZARD

- If you leave the key in the ignition switch, someone could start the engine.

WHAT CAN HAPPEN

- Accidental starting of the engine could seriously injure you or other bystanders.

HOW TO AVOID THE HAZARD

- Remove the key from the ignition switch and pull the wire off the spark plug before you do any maintenance. Also push the wire aside so it does not accidentally contact the spark plug.

Greasing and Lubrication

Service Interval/Specification

Grease and oil the machine after every 25 operating hours or once a year, whichever occurs first.

Grease Type: General-purpose grease.

Oil Type: SAE 10W or 10W30.

How to Grease

1. Disengage the power take off (PTO), set the parking brake, and turn the ignition key to "OFF" to stop the engine. Remove the key.
2. Clean the grease fittings with a rag. Make sure to scrape any paint off the front of the fitting(s).
3. Connect a grease gun to the fitting. Pump grease into the fittings.
4. Lubricate the impeller shaft bearing (Fig. 33).
5. Wipe up any excess grease.

Oil Drive Chain

1. Disengage the power take off (PTO), set the parking brake, and turn the ignition key to "OFF" to stop the engine. Remove the key.
2. Coat the entire chain with oil and allow to penetrate each roller (Fig. 33).
3. Place a few drops of oil on discharge chute rotator shaft and discharge chute mounting (Fig. 33).
4. Wipe off excess oil.

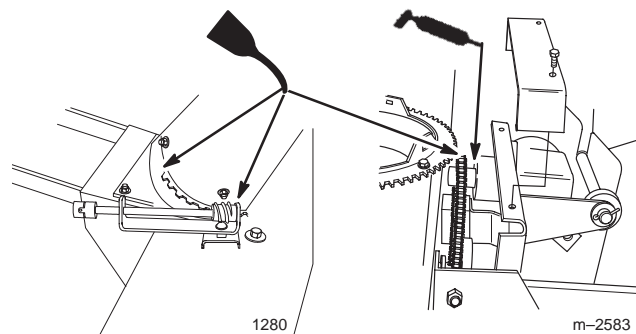

Figure 33

Check Gear Box Lubricant

1. Disengage the power take off (PTO), set the parking brake, and turn the ignition key to "OFF" to stop the engine. Remove the key.
2. Clean area around plug with a rag and remove plug (Fig. 34).
3. Add SAE 90 gear oil until level with bottom of hole in housing (Fig. 34).

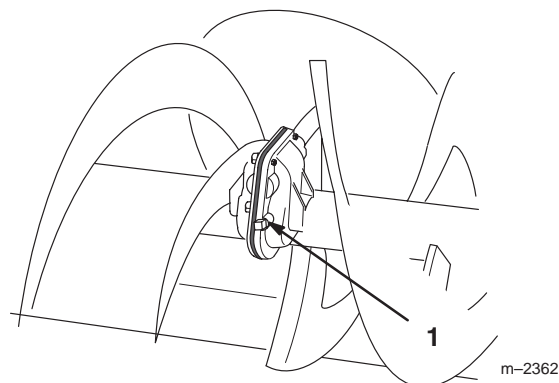

Figure 34

1. Plug

Adjusting Skids

The distance between the scraper blade and the ground is controlled by skids on each side of the housing. The height can be adjusted so the scraper blade will not catch on uneven surfaces

1. Disengage the power take off (PTO), set the parking brake, and turn the ignition key to "OFF" to stop the engine. Remove the key.
2. Move snowthrower to a level surface.
3. Loosen nuts securing skids to the housing until the skids slide up and down easily (Fig. 35).
4. Raise or lower skids equally on both sides, to obtain level scraping action, and tighten nuts (Fig. 35).

Note: On smooth, paved surfaces, scraper blade can be close to the surface. On uneven, gravel or crushed rock surfaces, adjust skids to raise scraper, to prevent catching or picking up rocks.

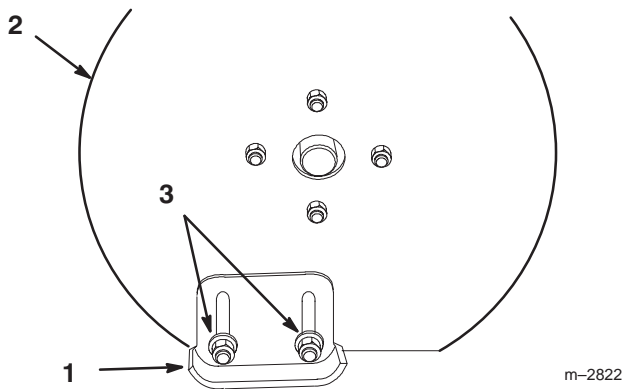

Figure 35

1. Skid
2. Housing
3. Nut

Replacing Scraper Blade

The scraper blade contacts the ground preventing damage to the snowthrower housing. Periodically inspect the scraper blade for wear. When scraper becomes worn, before working surface contacts the housing, replace the scraper blade.

1. Disengage the power take off (PTO), set the parking brake, and turn the ignition key to "OFF" to stop the engine. Remove the key.
2. Raise the attachment lift lever: Refer to Raising Attachments, and support the housing off the ground.
3. Remove nuts, washers, carriage bolts and scraper blade (Fig. 36).
4. Replace scraper blade and install with previously removed hardware (Fig. 36).

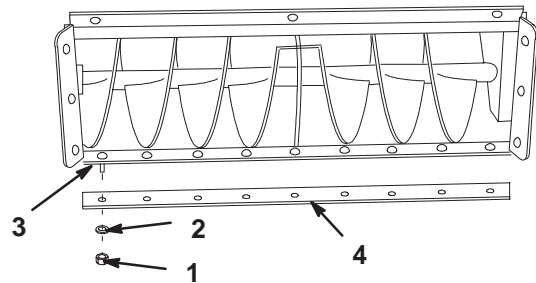

1281a

Figure 36

1. Nut
2. Washer
3. Carriage bolt
4. Scraper blade

IMPORTANT: The scraper should be higher above the pavement if the pavement surfaces on which the snowthrower will be used are cracked, rough or uneven.

Adjusting Drive Chain Tension

Check the drive chain tension after every 25 operating hours or once a year, whichever occurs first.
Adjustment as necessary to maintain proper tension.

1. Disengage the power take off (PTO), set the parking brake, and turn the ignition key to "OFF" to stop the engine. Remove the key.
2. Remove chain cover (Fig. 37).
3. Adjust chain tension block so chain deflects 3/8" to 5/8" between sprockets (Fig. 37).

IMPORTANT: Do not overtighten chain or excessive wear will occur.

4. Install chain cover with (2) 1/4 x 1/2" bolts (Fig. 37).

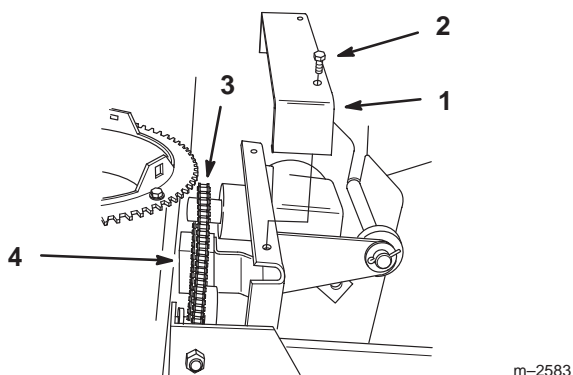

Figure 37

- | | |
|--------------------|------------------|
| 1. Chain cover | 3. Chain |
| 2. Bolt 1/4 x 1/2" | 4. Tension block |

Replace Drive Belt

1. Remove belt covers from tractor and snowthrower (Fig. 38),

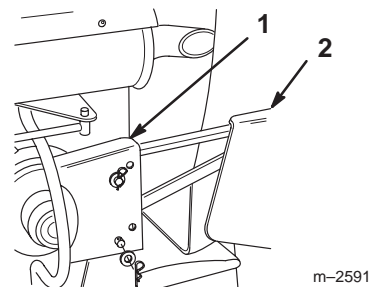

Figure 38

- | | |
|-----------------------|---------------------------|
| 1. Belt cover—tractor | 2. Belt cover—snowthrower |
|-----------------------|---------------------------|

2. Remove hairpin cotters from trunnion and bottom of yoke (Fig. 39).
3. Unlatch and remove locking clevis pin that secures yoke assembly to clutch shaft. Pivot yoke out and forward to remove from clutch shaft and engagement plate (Fig. 39).
4. Remove snowthrower belt from pulley (Fig. 39).
5. Assemble yoke and engagement plate and attach locking clevis pin, trunnion and hairpin cotters to secure (Fig. 39).

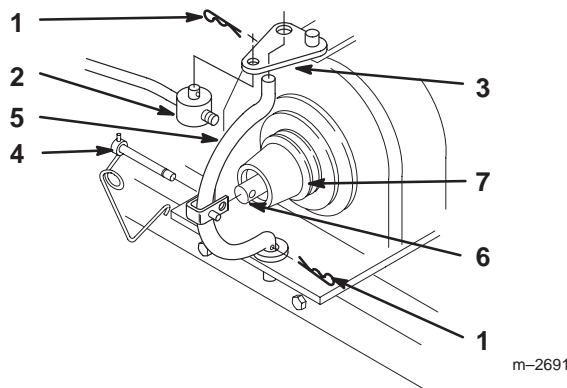

Figure 39

- | | |
|-----------------------|-----------------|
| 1. Hairpin cotter | 5. Yoke |
| 2. Trunnion | 6. Clutch shaft |
| 3. Engagement plate | 7. Pulley |
| 4. Locking clevis pin | |

6. Remove rear idler and replace belt (Fig. 40). Install rear idler.
7. Install belt covers on tractor and snowthrower (Fig. 38),

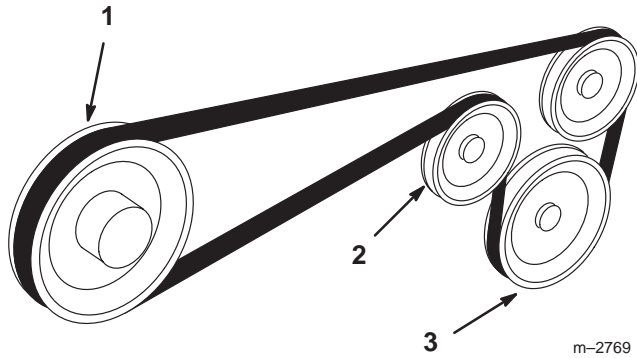

Figure 40

1. Outer groove of (PTO) power take off
2. Rear idler pulley
3. Snowthrower pulley

Storage

1. Before long term storage wash the machine with mild detergent and water to remove dirt and grime from the entire machine.
2. Check the condition of the scraper blade; refer to Reversing Scraper Blade, page 24.
3. Check the condition of the drive belt and chain.
4. Grease and oil the snowthrower; refer to Greasing and Lubrication, page 23.
5. Check and tighten all bolts, nuts, and screws. Repair or replace any part that is damaged or defective.
6. Paint all scratched or bare metal surfaces. Paint is available from your Authorized Service Dealer.
7. Coat inside auger housing and discharge chute with automotive wax to prevent rust and reduce the sticking of snow to these surfaces.
8. Store the machine in a clean, dry garage or storage area. Cover the machine to protect it and keep it clean.

Troubleshooting

PROBLEM	POSSIBLE CAUSES	CORRECTIVE ACTION
Snow does not discharge	<ol style="list-style-type: none"> 1. Discharge chute plugged. 2. Auger does not rotate. 3. Auger speed too low. 4. Forward speed too slow. 	<ol style="list-style-type: none"> 1. Clean chute with a stick. 2. See auger does not rotate. 3. Move throttle to "FAST". 4. Increase ground speed.
Auger does not rotate.	<ol style="list-style-type: none"> 1. Snow frozen to auger or housing. 2. Drive belt tension low. 3. Drive belt is worn, loose or broken. 4. Drive belt is off pulley. 5. Drive chain broken. 	<ol style="list-style-type: none"> 1. Scrape snow off with a stick. 2. Adjust belt tension. 3. Install new drive belt. 4. Install blade drive belt and check idler pulley and belt guides for correct position. 5. Replace or repair chain.
Abnormal vibration.	<ol style="list-style-type: none"> 1. Snow frozen to auger. 2. Drive belt off pulley. 3. Engine mounting bolts are loose. 4. Loose engine pulley, idler or snowthrower pulley. 5. Engine pulley is damaged. 	<ol style="list-style-type: none"> 1. Scrape snow off with stick. 2. Install drive belt and check idler pulley for correct position. 3. Tighten engine mounting bolts. 4. Tighten the appropriate pulley. 5. Contact Authorized Service Dealer.

