



44" or 52" SIDE DISCHARGE BAGGER

for
Proline Mid-Size Mowers
Model No. 30128 – 890001 & Up

Operator's Manual

IMPORTANT: Read this manual carefully. It contains information about your safety and the safety of others. Also become familiar with the controls and their proper use before you operate the product.

Introduction

We want you to be completely satisfied with your new product, so feel free to contact your local Authorized Service Dealer for help with service, genuine replacement parts, or other information you may require.

Whenever you contact your Authorized Service Dealer or the factory, always know the model and serial numbers of your product. These numbers will help the Service Dealer or Service Representative provide exact information about your specific product. You will find the model and serial number plate located in a unique place on the product as shown below.

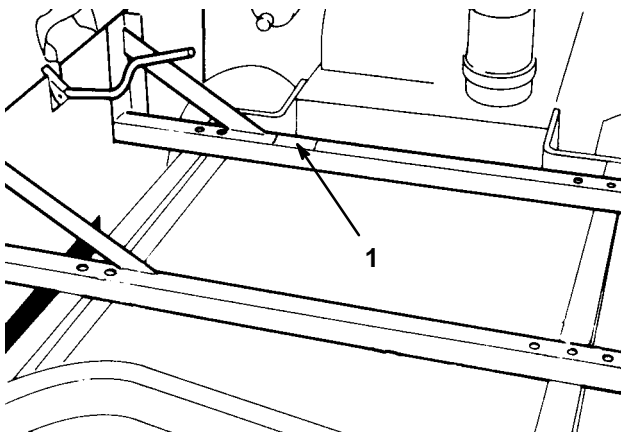

1. Model and Serial Number Plate

For your convenience, write the product model and serial numbers in the space below.

Model No: _____
Serial No. _____

The warning system in this manual identifies potential hazards and has special safety messages that help you and others avoid personal injury, even death. DANGER, WARNING and CAUTION are signal words used to identify the level of hazard. However, regardless of the hazard, be extremely careful.

DANGER signals an extreme hazard that will cause serious injury or death if the recommended precautions are not followed.

WARNING signals a hazard that may cause serious injury or death if the recommended precautions are not followed.

CAUTION signals a hazard that may cause minor or moderate injury if the recommended precautions are not followed.

Two other words are also used to highlight information. “Important” calls attention to special mechanical information and “Note” emphasizes general information worthy of special attention.

The left and right side of the machine is determined by sitting on the seat in the normal operator’s position.

Contents

	Page		Page
Installation	2	Maintenance	9
Loose Parts	2	Inspecting the Bagger	9
Installing the Bagger	3	Inspecting the Mower Blades	9
Removing the Bagger	7	Caring for the Grass Bag	9
Operation	8	Cleaning the Bagger	9
Emptying the Grass Bag	8	Storing the Bagger	9
Clearing Obstructions from the Bagger ...	8		
Operating and Bagging Tips	8		

Installation

Loose Parts

DESCRIPTION	QTY.	USE
Baffle (18"–for use on 44" deck)	1	Install baffle
Baffle (24"–for use on 52" deck)	1	
Screw (5/16" x 3/4")	2	
Seal Template–44" (for use with 44" deck)	1	Cut rubber extension
Seal Template–52" (for use with 52" deck)	1	
Back Panel	1	
Mounting Beam	2	Install mounting beams
Retainer Bolt	4	
Flange Nut (3/8"–16)	4	
Curved Bolt	2	Install mounting assembly on a 44" deck
Washer (3/8")	6	
Bolt (3/8" x 2 1/2")	2	
Locknut (3/8"–16)	4	
Bolt (3/8" x 2 1/2")	2	Install mounting assembly on a 52" deck
Washer (3/8")	8	
Bolt (3/8" x 4 1/2")	2	
Locknut (3/8"–16)	4	
Lockup Rod	1	Install lockup rod
Bolt (5/16" x 3/4")	2	
Flange Nut (5/16"–18)	2	
Grass Bag and Tray	1	Install grass bag and tray
Front Bag Support Tube	1	
Rear Bag Support Tube	1	
Truss Head Screw (5/16" 3/4")	10	
Flange Nut (5/16"–18)	10	

Attaching the Mounting Beams to the Back Panel

1. Secure the mounting beams to the back panel using four retainer bolts and four 3/8"-16 flange nuts (Fig. 3).

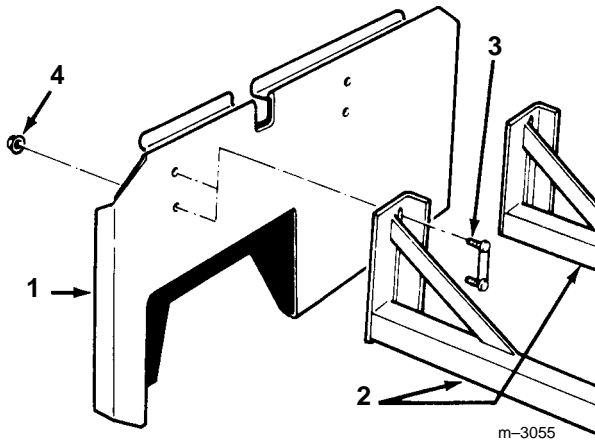

Figure 3

- | | |
|------------------|----------------------|
| 1 Back Panel | 3 Retainer Bolts |
| 2 Mounting Beams | 4 3/8"-16 Flange Nut |

Note: The back panel can be mounted onto the mounting beams in a range of vertical positions. When fully assembled, the back panel should be adjusted so that the grass bag tray is positioned slightly below the mower deck.

Preparing the Cutting Deck and Carrier Frames for Installation

1. Position the back panel and mounting beam assembly onto the cutting deck and carrier frame (Fig. 4). The rubber extension should be touching the back edge of the discharge opening (Fig. 5).

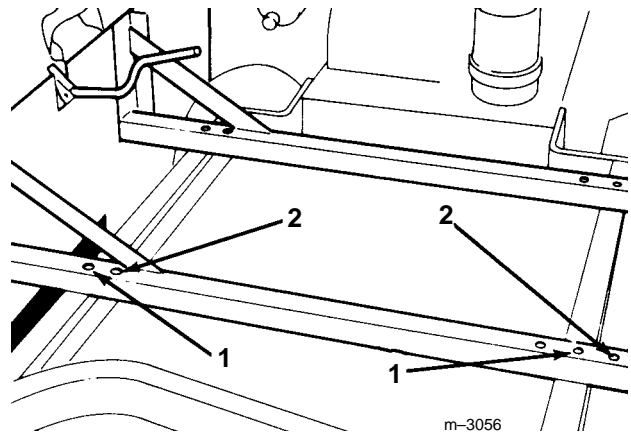

Figure 4

- | | |
|-------------------------------|-------------------------------|
| 1 Mounting Holes for 44" Deck | 2 Mounting Holes for 52" Deck |
|-------------------------------|-------------------------------|

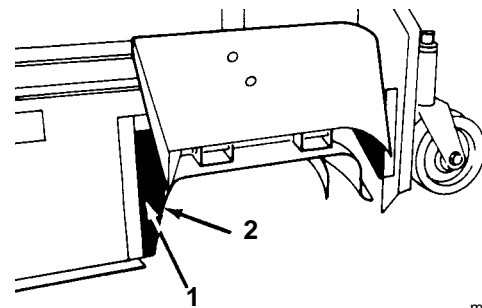

Figure 5

- | | |
|--------------------|----------------------------------|
| 1 Rubber Extension | 2 Back Edge of Discharge Opening |
|--------------------|----------------------------------|

2. Using each mounting beam as a template, locate and drill four 1/2" diameter holes in the carrier frame, if no holes already exist.

Installing the Mounting Assembly on a 44" Deck

Note: If you are installing the bagger on a 52" deck, skip this section.

1. Insert the flat end of the curved screw into one of the holes in the carrier frame for the rear mounting beam (Fig. 6).
2. Insert the threaded end of the curved bolt through the appropriate hole in the rear mounting beam and secure it with a 3/8" washer and 3/8"-16 locknut (Fig. 6).
3. Repeat steps 1 and 2 for the other hole in the rear mounting beam.

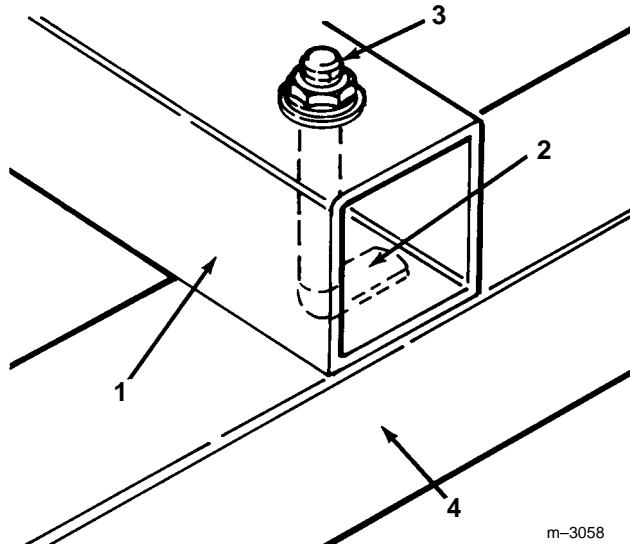

Figure 6

- | | |
|----------------------|-----------------------------------|
| 1 Rear Mounting Beam | 3 3/8" Washer and 3/8"-16 Locknut |
| 2 Curved Bolt | 4 Carrier Frame |

4. Secure the front mounting beam to the carrier frame with two 3/8" x 2 1/2" bolts, four 3/8" washers, and two 3/8" locknuts.

Note: The washers should be positioned on top of the beam and under the carrier frame.

Installing the Mounting Assembly on a 52" Deck

Note: If you are installing the bagger on a 44" deck, skip this section.

1. Secure the rear mounting beam to the carrier frame with two 3/8" x 4 1/2" bolts, four 3/8" washers, and two 3/8" locknuts.
- Note:** The washers should be positioned on top of the beam and under the carrier frame.
2. Secure the front mounting beam to the carrier frame with two 3/8" x 2 1/2" bolts, four 3/8" washers, and two 3/8" locknuts.

Note: The washers should be positioned on top of the beam and under the carrier frame.

Installing the Lockup Rod

1. Measure 7" (on a 44" deck) or 7 1/4" (on a 52" deck) from the edge of the deflector and make a mark parallel to the edge (Fig. 7).

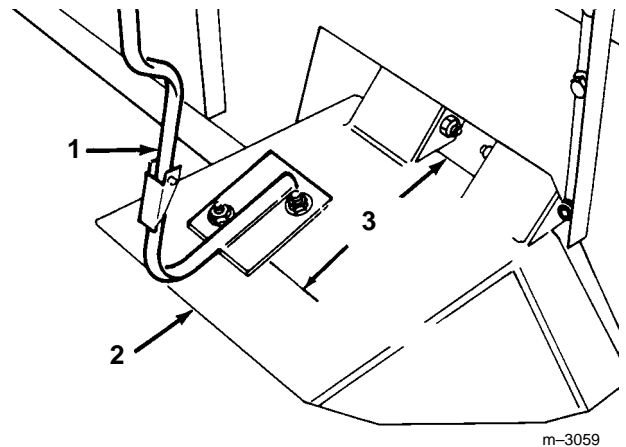

Figure 7

- | | |
|--------------------|--------------------------------------|
| 1 Lockup Rod | 3 7" (44" Deck) or 7 1/4" (52" Deck) |
| 2 Deflector Shield | |

2. Position the outside mounting hole on the lockup rod on the line you drew.

3. Raise the deflector and move the lockout rod back and forth along the course of the line you drew on the deflector until the rod is centered in the back panel slot (Fig. 8).

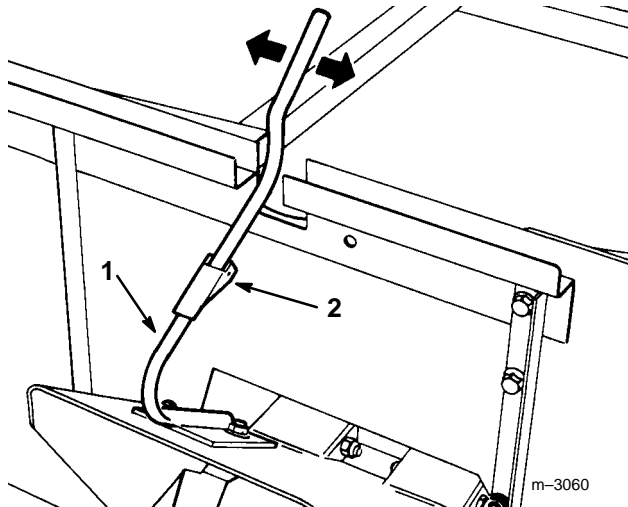

Figure 8

- 1 Lockup Rod 2 Lockup Latch

4. Using the lockup rod as a template, mark and drill two 11/32" diameter holes in the deflector.
5. Secure the lockup rod to the deflector using two 5/16" x 3/4" bolts and two 5/16"-18 flange nuts.

Note: The flange nuts should be on top of the deflector.

Assembling and Installing the Grass Bag

1. Position the rear bag support tube ends between the bag rods and the bag tray (Fig. 9).

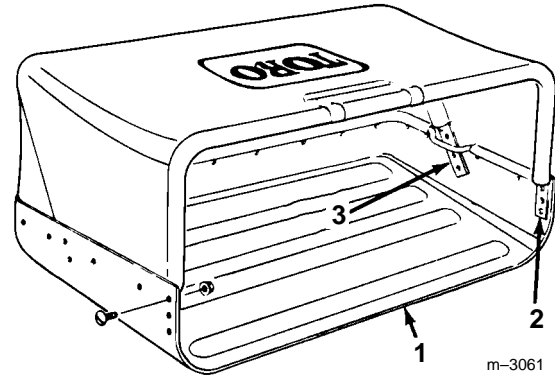

Figure 9

- 1 Grass Bag Tray 3 Rear Bag Support Tube
2 Front Bag Support Tube

2. Secure the front bag support tube to the grass bag tray using six 5/16" x 3/4" truss head screws and six 5/16"-18 flange nuts.
3. Secure the rear bag support tube to the grass bag tray using four 5/16" x 3/4" truss head screws and four 5/16"-18 flange nuts.

Note: Use only the bottom two mounting holes on each side of the rear bag support tube to secure it to the tray.

4. Move the lockup rod into the slot in the back panel.
5. Hook the front bag support tube into the lip on the top of the back panel and lower the bag tray against the back panel.
6. Hook the lockup latch (Fig. 8) on the bag tube.
7. Adjust the back panel height by sliding the retainer bolts up or down in the slots in the mounting beams (Fig. 3) so that the bag tray is slightly below the bottom of the deck.

Note: This adjustment may need to be made whenever you adjust the mower height of cut.

Removing the Bagger

DANGER

POTENTIAL HAZARD

- Sometimes people are tempted to operate the mower without the grass deflector or entire bagger in place. This exposes you and others to thrown debris and blade contact.

WHAT CAN HAPPEN

- You and others may die or be injured severely if you are hit by thrown debris or cut by the blade.

HOW TO AVOID THE HAZARD

- Always operate the mower with the complete grass bagger mounted in place or use the mower to side discharge, making sure that the grass deflector is in the down position.

1. Remove the grass bag from the back panel.
2. Remove the bolts, washers, and nuts securing the mounting beams to the carrier frame, remove the mounting assembly, and re-thread the bolts, washers, and nuts into the mounting beams (Fig. 4 and Fig. 6).
3. Remove screws and nuts securing the lockup rod and remove the lockup rod. Replace the screws and nuts into the holes in the deflector.
4. Remove the baffle screw closest to the opening in the deck (Fig. 1).
5. Pivot the baffle to the storage position and secure it with the screw (Fig 1).
6. Store all bagger parts in a convenient place.

Operation

CAUTION

To Avoid Personal Injury:

- **Become familiar with all operating and safety instructions in the operator's manual for your mower before using this attachment.**
- **Never do maintenance or repairs while the engine is running.**

Emptying the Grass Bag

1. Disengage the power take off (PTO) to stop the mower blades and release the traction drive or shift to NEUTRAL as applicable for your mower.
2. Remove and empty the grass bag.
3. Reinstall the grass bag and resume operation.

Clearing Obstructions from the Bagger

1. Disengage the power take off (PTO) to stop the mower blades and release the traction drive or shift to NEUTRAL as applicable for your mower.
2. Remove the grass bag and empty it if full.
3. Carefully remove and clear the obstruction from the mower.
4. Reinstall the grass bag and resume operation.

Operating and Bagging Tips

1. Remember that the mower is wider with the bagger installed. By turning too sharply in confined places you may damage the bagger.
2. Do not trim with the right side of the mower because you could damage the bagger.
3. When mowing rough or uncertain, use care to avoid damaging the bagger.
4. Air flow is required to cut grass and propel it into the bag. Setting the height-of-cut too low, especially in heavy or long grass can restrict the air flow and plug the mower or bagger.

To avoid plugging, double-cut the grass, first at a high height-of-cut and then lower the mower to the desired setting. Also, try to leave one side of the mower out of the uncut grass, allowing air to be drawn into the mower housing.

Maintenance

Inspecting the Bagger

Inspect the bagger after the first ten hours of operation and monthly thereafter.

1. Check the grass bag, back panel, and lockup rod for damage. Replace any damaged parts.

DANGER

POTENTIAL HAZARD

- The grass bag material may tear, wear, and eventually deteriorate.

WHAT CAN HAPPEN

- You or bystanders could be severely injured by flying debris or thrown objects that pass through a worn or deteriorated grass bag.

HOW TO AVOID THE HAZARD

- Frequently check the grass bag for holes, wear, and other deterioration. Do not wash the grass bag. If the bag has deteriorated, install a new grass bag.

2. Tighten all nuts bolts and screws.

Inspecting the Mower Blades

1. Inspect the mower blades regularly and whenever a blade strikes a foreign object.
2. If blades are badly worn or damaged, install new blades. Refer to your mower operator's manual for complete blade maintenance.

Caring for the Grass Bag

1. Do not wash the grass bag.
2. To prevent rapid deterioration of bag material, store the bag so it dries completely after each use.

CAUTION

POTENTIAL HAZARD

- If you store grass clippings in the grass bag, under the right conditions, spontaneous combustion (a fire-generating process that occurs without an external source of ignition) could occur.

WHAT CAN HAPPEN

- If a fire occurs, property could be damaged and/or someone could be injured.

HOW TO AVOID THE HAZARD

- The cloth grass bag is not a storage container. Never store grass clippings and debris in the grass bag.

Cleaning the Bagger

1. Frequently clean the inside and outside of the back panel and the mower deck, using water sprayed from a hose. Use a mild automotive detergent to remove stubborn dirt. Do not wash the grass bag.
2. Ensure you remove matted grass from all parts.
3. After washing let all parts dry thoroughly.

Storing the Bagger

1. Clean the bagger (refer to Cleaning the Bagger, page 9).
2. Inspect the bagger for damage (refer to Inspecting the Bagger, page 9).
3. Ensure the grass bag is empty and dry.
4. Store the bagger in a clean, dry place, out of direct sunlight. This extends the life of the bagger. If you must store the bagger outside, cover it with a weatherproof cover.

