



ProLine
14 HP – 48”
Mid-Size Mower

Model No. 30196 – 890001

Operator's Manual

IMPORTANT: Read this manual carefully. It contains information about your safety and the safety of others. Also become familiar with the controls and their proper use before you operate the product.

Introduction

Thank you for purchasing a Toro product.

All of us at Toro want you to be completely satisfied with your new product, so feel free to contact your local Authorized Service Dealer for help with service, genuine replacement parts, or other information you may require.

Whenever you contact your Authorized Service Dealer or the factory, always know the model and serial numbers of your product. These numbers will help the Service Dealer or Service Representative provide exact information about your specific product. You will find the model and serial number plate located in a unique place on the product as shown below.

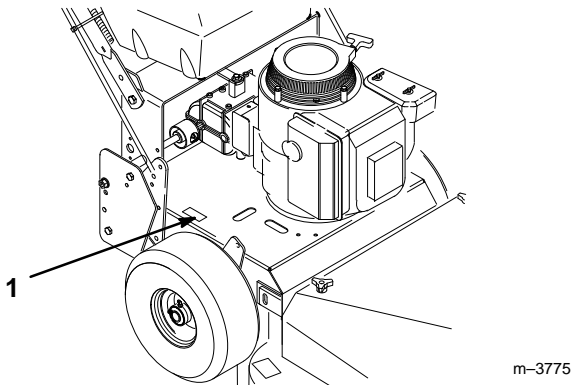

1. Model and Serial Number Plate

For your convenience, write the product model and serial numbers in the space below.

Model No: _____
Serial No. _____

Read this manual carefully to learn how to operate and maintain your product correctly. Reading this manual will help you and others avoid personal injury and damage to the product. Although we design, produce and market safe, state-of-the-art products, you are responsible for using the product properly and safely. You are also responsible for training persons, who you allow to use the product, about safe operation.

The warning system in this manual identifies potential hazards and has special safety messages that help you and others avoid personal injury, even death. **DANGER**, **WARNING** and **CAUTION** are signal words used to identify the level of hazard. However, regardless of the hazard, be extremely careful.

DANGER signals an extreme hazard that will cause serious injury or death if the recommended precautions are not followed.

WARNING signals a hazard that may cause serious injury or death if the recommended precautions are not followed.

CAUTION signals a hazard that may cause minor or moderate injury if the recommended precautions are not followed.

Two other words are also used to highlight information. “Important” calls attention to special mechanical information and “Note” emphasizes general information worthy of special attention.

The left and right side of the machine is determined by standing\sitting on the seat in the normal operator’s position.

!	WARNING:	!
The engine exhaust from this product contains chemicals known to the State of California to cause cancer, birth defects, or other reproductive harm.		

Contents

	Page		Page
Safety	2	Stopping the Machine	20
Safe Operating Practices	2	Adjusting Height-of-Cut	21
Slope Chart	5	Height-of-Cut Chart	22
Safety and Instruction Decals	7	Maintenance	23
Gasoline and Oil	9	Service Interval Chart	23
Recommended Gasoline	9	Air Cleaner	24
Stabilizer/Conditioner	9	Engine Oil	25
Filling the Fuel Tank	9	Spark Plug	27
Check Engine Oil Level	9	Cutting Blades	28
Assembly	10	Adjusting Blade Brake	31
Loose Parts	10	Tire Pressure	31
Install Front Castors	11	Cleaning the Cooling System	31
Install Upper Handle	11	Greasing and Lubrication	32
Connect Throttle Cable	13	Brake	33
Install Blade Control (PTO) Rod	14	Fuel Tank	34
Install Shift Lever	14	Fuel Filter	35
Mount Fuel Tank	15	Replacing the Wheel Belt	35
Operation	16	Replacing the Traction Belt	36
Think Safety First	16	Replacing the Mower Belts	36
Controls	16	Adjusting Grass\Mud Scraper	37
Parking Brake	17	Replacing the Grass Deflector	37
Starting and Stopping the Engine	18	Wiring Diagram	38
Operating Blade Control (PTO)	19	Cleaning and Storage	39
The Safety Interlock System	19	Troubleshooting	40
Driving Forward or Backward	20	Warranty	Back Cover

THE ENCLOSED ENGINE OWNER'S MANUAL IS SUPPLIED FOR CALIFORNIA EMISSION CONTROL REGULATION INFORMATION ON EMISSION SYSTEMS, MAINTENANCE AND WARRANTY.

KEEP THIS ENGINE OWNER'S MANUAL WITH YOUR UNIT. SHOULD THIS ENGINE OWNER'S MANUAL BECOME DAMAGED OR ILLEGIBLE, REPLACE IMMEDIATELY. REPLACEMENTS MAY BE ORDERED THROUGH THE ENGINE MANUFACTURER.

Safety

This machine meets or exceeds safety requirements B71.4–1990 of the American National Standards Institute for commercial mowers, in effect at time of production. However, improper use or maintenance by the operator or owner can result in injury. To reduce the potential for injury, comply with these safety instructions and always pay attention to the safety alert  symbol which means CAUTION, WARNING or DANGER—“personal safety instruction.” Failure to comply with the instruction may result in personal injury.

Safe Operating Practices

This product is capable of amputating hands and feet and throwing objects. Always follow all safety instructions to avoid serious injury or death.

WARNING

POTENTIAL HAZARD

- **Engine exhaust contains carbon monoxide, which is an odorless, deadly poison.**

WHAT CAN HAPPEN

- **Carbon monoxide can kill you and is also known to the State of California to cause birth defects.**

HOW TO AVOID THE HAZARD

- **Do not run engine indoors or in an enclosed area.**

This mower is designed for cutting and recycling grass or, when equipped with a grass bag, for catching cut grass. Any use for purposes other than these could prove dangerous to user or bystanders.

Note: This engine is NOT equipped with a spark arrester muffler. Use or operation of this mower in the State of California on any forest-covered, brush-covered or unimproved grass-covered land, without an approved spark arrester muffler, is a violation of the law. Other states may have similar laws.

General Operation

1. Read this manual carefully before operating the mower. Become familiar with the controls and proper use of the mower. Never allow children under 16 years of age to operate the mower. Never allow adults to operate mower without proper instructions.
2. The operator of the mower is responsible for keeping everyone, especially children and pets, away from area of operation. The operator is responsible for accidents or hazards occurring to other people or their property.
3. Thoroughly inspect area where mower will be used and remove sticks, stones, wire, and debris that could be picked up and thrown by mower. Watch for foreign objects while mowing.
4. Wear long pants and substantial shoes. Do not operate mower while wearing open-toed shoes, jewelry, loose clothing or when barefoot.
5. Check fuel level before starting engine. Because fuel is highly flammable, handle it carefully.
 - A. Use an approved fuel container.
 - B. Fill fuel tank outdoors, not indoors.
NEVER ADD FUEL TO AN ENGINE THAT IS RUNNING OR HOT.
 - C. Install gas cap on fuel container and gas tank, and wipe up any spilled gasoline before starting engine.

D. Do not smoke while refueling.

6. Keep all guards, shields, safety devices, cover-deflector assembly, optional grass catcher, optional side discharge chute or optional discharge tunnel plug in place. Repair or replace damaged parts, including decals. Check all safety devices before each use.
7. Engine, blade and self-propelled drive (self-propelled model) are designed to stop when control bails are released. Ensure control and brake function properly before each use of mower.
8. Disengage the self-propelled mechanism or drive clutch (self-propelled model) before starting the engine.
9. Before using, always visually inspect to see that the blades, blade fasteners and cutter assembly are not worn or damaged. Replace worn or damaged blades and fasteners in sets to preserve balance.

While Operating

1. Do not run engine indoors.
2. Start the engine carefully according to instructions and with feet well away from the blade.
3. Always maintain secure footing. Keep a firm grip on the handle and walk; never run. Never operate mower in wet grass. Mow only in daylight or in good artificial light.
4. Mow across the face of slopes; never up and down. Use extreme caution when changing direction on slopes. Do not mow excessively steep slopes. Wear skid resistant shoes on slopes.
5. Always wear safety glasses or eye shields during operation to protect eyes from foreign objects that may be thrown from the machine.
6. Keep face, hands, and feet away from the mower housing and cutter blade when the engine is running. Blade can cause injury to hands and feet. Stay behind the handle until the engine stops.
7. Use extreme caution when reversing or pulling the mower towards you.
8. Since the blade rotates for a few seconds after the control bar is released, stay behind the handle until all moving parts stop.
9. After striking a foreign object or if mower vibrates abnormally, stop engine and remove wire from spark plug. Check mower for damage and make all repairs before using mower again. If major repairs are ever needed or if assistance is desired, contact your local Authorized TORO Service Dealer.
10. Stop the engine and wait for all moving parts to stop before adjusting the height-of-cut.
11. Stop the blade when moving the mower outside the lawn area.
12. Stop engine before leaving the operator's position—behind the handle. Disconnect wire from spark plug if mower will be unattended.
13. Do not touch engine while it is running or shortly after it is stopped because engine will be hot enough to cause a burn.
14. Refuel only when engine is cool.
15. If mower must be transported, turn off engine and stay behind the handle until all moving parts stop. Disconnect spark plug wire.

Maintenance And Storage

1. Perform only those maintenance instructions described in this manual. If major repairs are ever needed or if assistance is desired, contact your local Authorized TORO Service Dealer.
2. Before mower is cleaned, inspected, serviced, or adjusted, stop engine and disconnect wire from spark plug. Keep wire away from plug to prevent accidental starting.
3. To ensure the mower is in safe operating condition, frequently check and keep all nuts, bolts, and screws tight. Ensure blade bolt is tightened to 85–110 ft-lb (115–149 N·m).
4. When servicing blade, refer to blade maintenance section for correct installation and servicing procedures.
5. To reduce fire hazard, keep engine free of excessive grease, grass, leaves, and accumulations of dirt.
6. Allow engine to cool before storing mower in any enclosure. Do not store mower with gasoline in fuel tank near any open flame or where gasoline fumes may be ignited by a spark.
7. Do not overspeed the engine by changing governor settings.
8. At the time of manufacture, the mower conformed to the safety standards in effect for rotary mowers. To assure best performance and continued safety certification of the mower, use genuine TORO replacement parts and accessories. Replacement parts and accessories made by other manufacturers may result in non-conformance with the safety standards, and that could be dangerous.

Slope Chart

Read all safety instructions on pages 2-7.

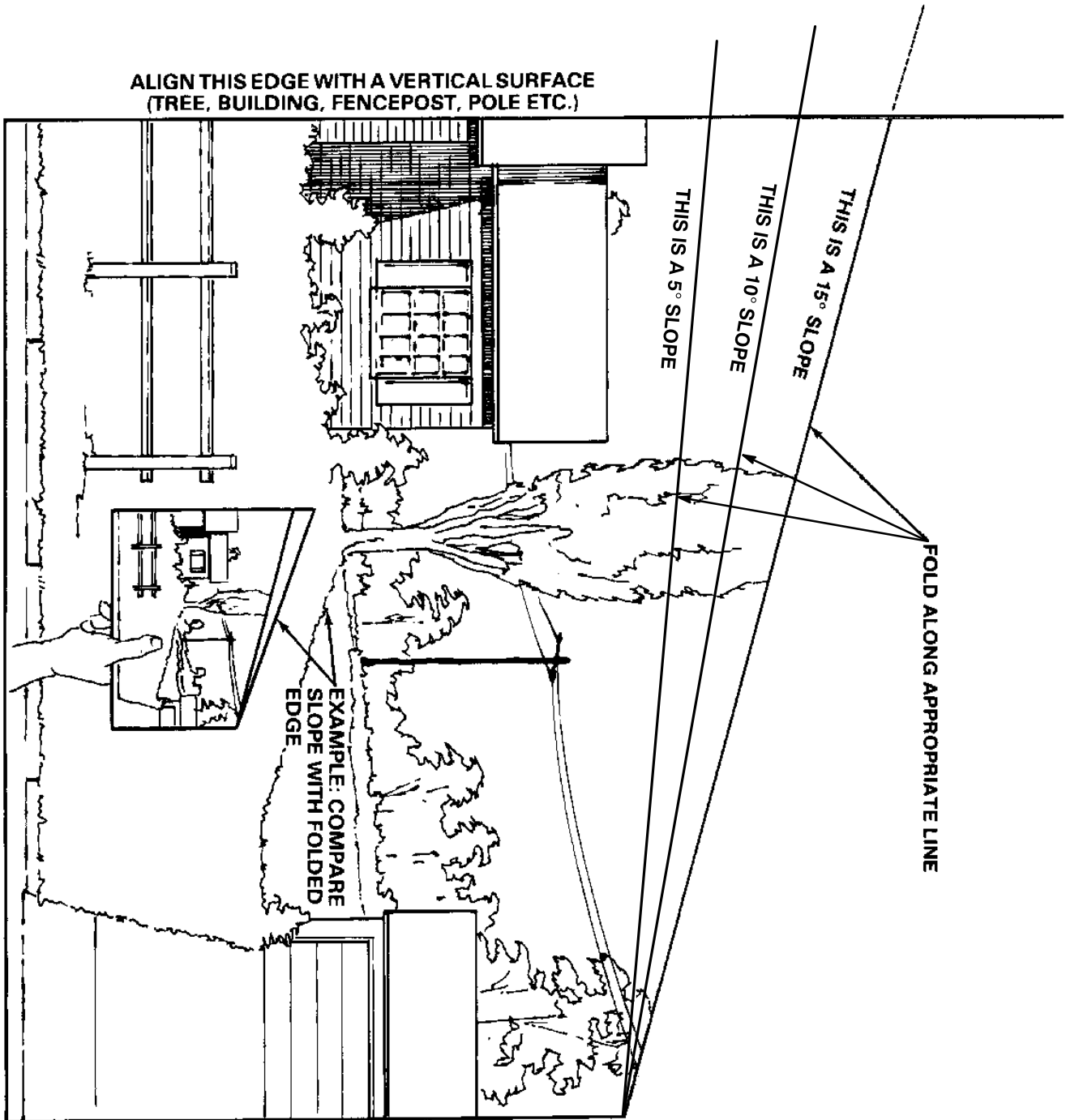

Safety and Instruction Decals



Safety decals and instructions are easily visible to the operator and are located near any area of potential danger. Replace any decal that is damaged or lost.

ON UPPER CONTROL BAR
(Part No. 82-2290)



ON LOWER CONTROL BAR
(Part No. 82-2280)

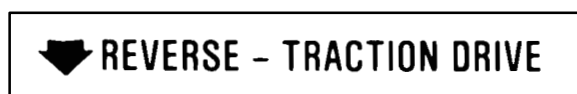

ON TOP-FRONT OF MOWER
(Part No. 66-1340)



ON CONTROL PANEL
(Part No. E323564)

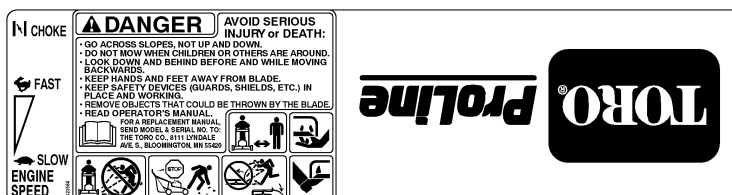

ON THE GEAR SELECTION PANEL
(Part No. E323560)

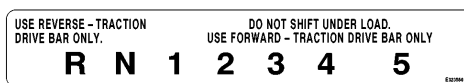

ABOVE MUFFLER
(Part No. 63-8440)



ABOVE GRASS DEFLECTOR
(Part No. 67-5360)



ON TOP-LEFT SIDE OF MOWER
(Part No. 43-8480)



ON GRASS DEFLECTOR
(Part No. 93-1122)



**ON REAR OF MOWER
(Part No. E324594)**

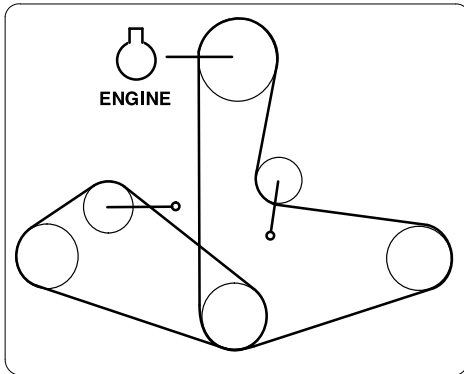

**ON PARKING BRAKE
(Part No. E323558)**

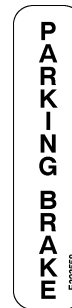

**ON LEFT SIDE OF HANDLE FRAME
(Part No. E323563)**

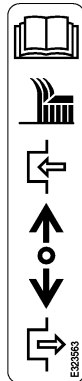

**ALONG LEFT SIDE OF FUEL TANK
(Part No. 95-2814)**

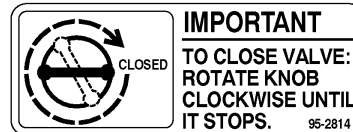

**ON REAR FRAME
(Part No. E323562)**



**ON REAR-LEFT CORNER OF MOWER
(Part No. 68-8340)**

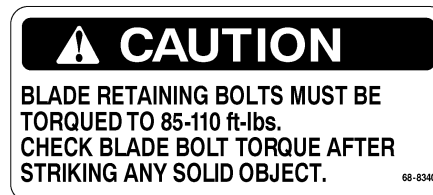

Gasoline and Oil

Recommended Gasoline

Use UNLEADED Regular Gasoline suitable for automotive use (85 pump octane minimum). Leaded regular gasoline may be used if unleaded regular is not available.

IMPORTANT: Never use methanol, gasoline containing methanol, or gasohol containing more than 10% ethanol because the fuel system could be damaged. Do not mix oil with gasoline.

DANGER

POTENTIAL HAZARD

- In certain conditions gasoline is extremely flammable and highly explosive.

WHAT CAN HAPPEN

- A fire or explosion from gasoline can burn you, others, and cause property damage.

HOW TO AVOID THE HAZARD

- Use a funnel and fill the fuel tank outdoors, in an open area, when the engine is cold. Wipe up any gasoline that spills.
- Do not fill the fuel tank completely full. Add gasoline to the fuel tank until the level is 1/4" to 1/2" (6 mm to 13 mm) below the bottom of the filler neck. This empty space in the tank allows gasoline to expand.
- Never smoke when handling gasoline, and stay away from an open flame or where gasoline fumes may be ignited by a spark.
- Store gasoline in an approved container and keep it out of the reach of children. Never buy more than a 30-day supply of gasoline.

Stabilizer/Conditioner

Add the correct amount of gas stabilizer/conditioner to the gas.

- Keeps gasoline fresh during storage
- Cleans the engine while it runs
- Eliminates gum-like buildup in the fuel system, which causes hard starting

IMPORTANT: Never use fuel additives containing methanol or ethanol.

Filling the Fuel Tank

1. Shut the engine off.
2. Clean around the fuel tank cap and remove the cap. Use a funnel and add unleaded regular gasoline to the fuel tank, until the level is 1/4 to 1/2 inch (6 mm to 13 mm) below the bottom of the filler neck. This space in the tank allows gasoline to expand. Do not fill the fuel tank completely full.
3. Install the fuel tank cap securely. Wipe up any gasoline that may have spilled.

Check Engine Oil Level

Before you start the engine and use the machine, check the oil level in the engine crankcase; refer to Checking Oil Level, page 26.

Assembly

Loose Parts

Note: Use the chart below to verify all parts have been shipped.

DESCRIPTION	QTY.	USE
Castor assemblies	2	Install front castors to mower
Bolt 3/8–16 x 3/4" (19 mm)	8	
Flange nut 3/8–16	8	
Upper handle	1	Install upper handle to frame
Bolt 3/8–16 x 1" (26 mm)	4	
Locknut 3/8–16	4	
Plastic terminal	1	
Wire tie	1	
Rod fitting	2	Install traction control rods
Clevis pin	2	
Washer 1/4"	2	
Hairpin cotter	4	
PTO rod	1	Install PTO rod
Hairpin cotter	2	
Shift lever	1	Install shift lever to transmission
Rubber seal	1	
Square hole washer	1	
Spring washer	1	
Locknut	1	

DESCRIPTION	QTY.	USE
Fuel tank	1	Install fuel tank
Bolt 5/16-1/ x 7/8" (22.5 mm)	2	
Lock washer 5/16"	2	
Washer 5/16"	4	
Stud	2	
Spring	2	
Hose clamp	1	
Operator's Manual	1	Read before operating machine
Engine Operator's Manual	1	
Parts Catalog	1	
Registration card	1	

Install Front Castors

- Align castors with holes on top and front of mower and insert (8) 3/8-16 x 3/4" (19 mm) bolts through mower. Secure with (8) 3/8-16 flange nuts below mower (Fig. 1).

Note: Tighten lower bolts first to pull castor against front, then top bolts last.

- Torque bolts to 30-35 ft. lb. (40-47 N•m).

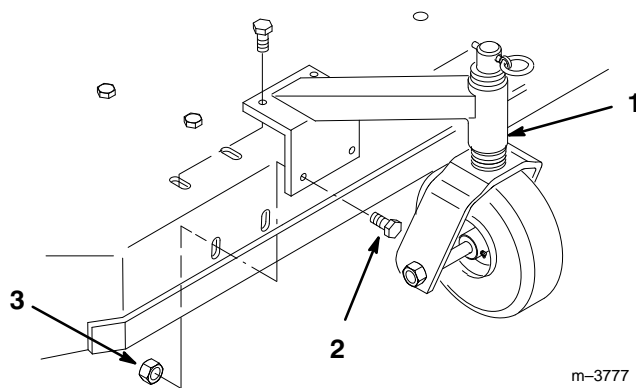

Figure 1

- Front castor
- Bolt 3/8-16 x 3/4" (19 mm)
- Flange nut 3/8-16

Install Upper Handle

- Position handle outside frame and align upper handle mounting holes with desired mounting holes in rear frame. High, medium or low according to operators height (Fig. 2).
- Secure each side with (2) 3/8-16 x 1" (26mm) bolts and (2) 3/8-16 locknuts (Fig. 2).
- Torque bolts to 25 ft. lbs. (34 N•m).

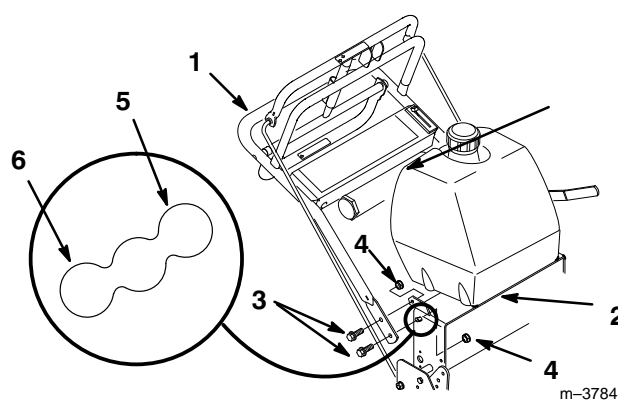

Figure 2

- Upper handle
- Rear frame
- Bolt 3/8-16 x 1" (26mm)
- Locknut 3/8
- Low
- High

Connect Wire Harness

4. Route wire harness inside of frame, along left handle and over throttle cable. Compress wire harness covering and press into lower and upper holes in rear of control panel (Fig. 3).
5. Thread harness up through rear tube of traction handle (Fig. 3).

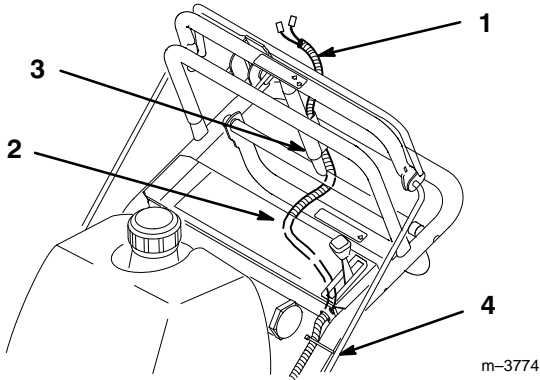

Figure 3

- | | |
|------------------|-------------|
| 1. Wire harness | 3. Tube |
| 2. Control panel | 4. Wire tie |

6. Insert terminals into plastic plug until the clips snap into position (Fig. 3). If they do not snap turn around.
7. Push plug onto switch so latch interlock (Fig. 3).
8. Secure wire harness and throttle cable to left handle, away from PTO lever, with wire tie (Fig. 3).

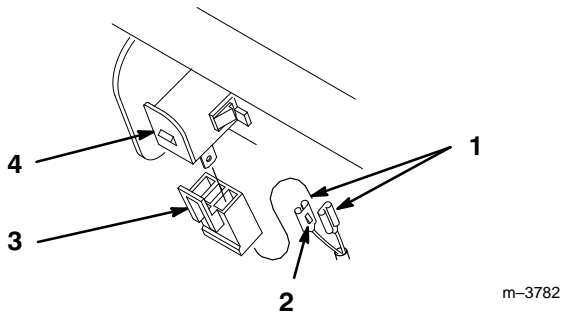

Figure 4

- | | |
|-------------|-----------------|
| 1. Terminal | 3. Plastic plug |
| 2. Clip | 4. Switch |

Install Traction Control Rods

1. Thread trunnions equal distance onto each control rod. For a starting point thread on approximately 2 in. (51 mm) (Fig. 5).
2. With trunnion rod up, slide clevis pins through rod fittings and mounting holes in idler brackets (from outside) (Fig. 5). Secure with 1/4" (6 mm) washers and hairpin cotters (Fig. 5).

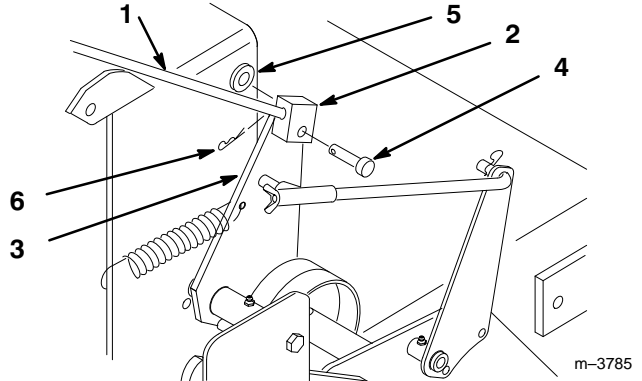

Figure 5

- | | |
|------------------|-----------------------|
| 1. Control rod | 4. Clevis pin |
| 2. Trunnion | 5. Washer 1/4" (6 mm) |
| 3. Idler bracket | 6. Hairpin cotter |

3. Check the gap between upper control bar and fixed bar with wheel drive fully engaged. Gap should be approximately 1 to 1-1/4 in. (25–32 mm) (Fig. 6).

Note: The upper control bar and fixed bar must be parallel in the engaged, relaxed and brake positions.

4. Check operation. If adjustment is required, remove hairpin cotter securing rod to upper control bar. Thread rod in or out of fitting for proper position and install into upper control bar with hairpin cotter.
5. After adjusting control rods, check parking brake adjustment, refer to: Brake page 33 for instructions.

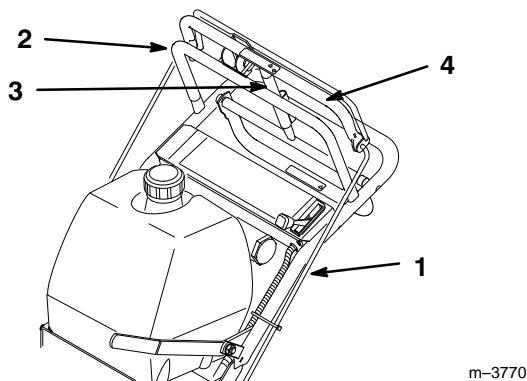

Figure 6

- | | |
|----------------------|------------------------|
| 1. Control rod | 3. Parking brake lever |
| 2. Fixed control bar | 4. Upper control bar |

Connect Throttle Cable

1. Place throttle control lever in FAST position.(Fig. 7).
2. Hook wire Z-bend into hole of speed control lever (Fig. 7).
3. Loosen cable clamp screw allowing cable installation, but do not tighten (Fig. 7).
4. Move control cable casing and wire until hole in speed control lever is aligned with hole in base plate. Insert a 1/4 in. (6.35 mm) diameter pin or bolt into aligned holes to hold adjustment.
5. Pull throttle cable slightly to remove any slack and tighten cable clamp screw to lock adjustment in place.
6. Remove alignment pin and check control operation.

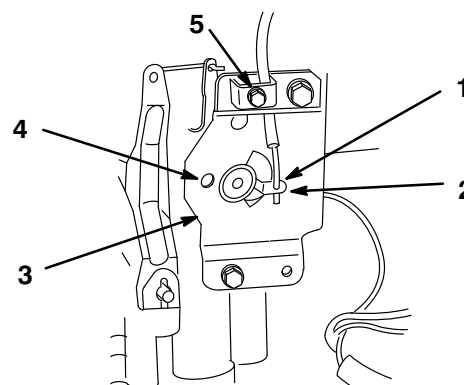

Figure 7

- | | |
|------------------------|-------------------------------------|
| 1. Wire Z-bend | 4. Alignment holes 1/4 in. (6.35mm) |
| 2. Speed control lever | 5. Cable clamp |
| 3. Base plate | |

Install Blade Control (PTO) Rod

1. Rotate blade control lever (PTO) vertical away from left handle so rod drops down.
2. Remove hairpin cotters from bottom end of blade control rod (PTO) (Fig. 8).
3. Secure blade control (PTO) rod through hole in bellcrank with hairpin cotters (Fig. 8).

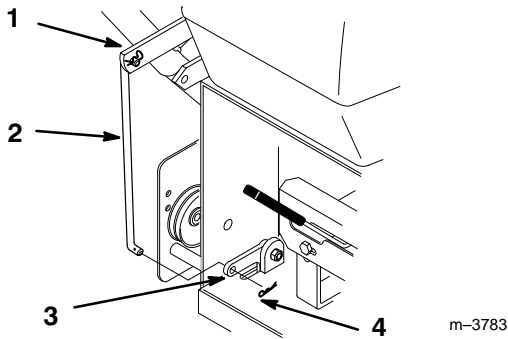

Figure 8

- | | |
|------------------------|-------------------|
| 1. Blade control lever | 3. Bellcrank |
| 2. Blade control rod | 4. Hairpin cotter |

Install Shift Lever

1. Remove the 3/8" locknut and spring disk washer from the stud on top of the transmission.

Note: Do not remove rubber seal washer and square hole washer from transmission shaft.

2. Slide shift lever through control panel and align mounting hole in lever with square on transmission shaft. Secure lever to transmission with previously removed spring washer and locknut (Fig. 9).
3. Replace the spring washer, dish down, and locknut (Fig. 8).
4. Torque nut to 35 ft. lbs. (47 N•m).
5. Shift lever to second gear and check alignment of lever in slot of shifter plate. Clearance between top of lever and the top of the slot should be about equal to the clearance between bottom of the lever and the bottom of the slot.
6. If clearance is not correct, remove lever and bend it slightly to adjust.

Note: Do not bend lever while attached to transmission shaft or damage may occur.

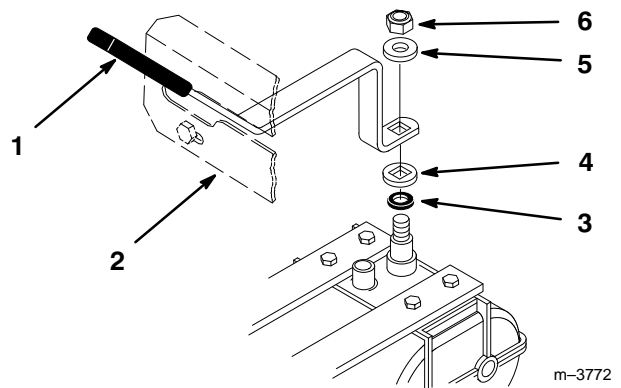

Figure 9

- | | |
|-----------------------|-----------------------|
| 1. Shift lever | 4. Square hole washer |
| 2. Control panel | 5. Spring washer |
| 3. Rubber seal washer | 6. Locknut 3/8 |

Mount Fuel Tank

1. Align fuel tank to top of rear frame and secure fuel tank right side with (2) 5/16–18 x 7/8 in. (22.5 mm) bolts, (2) 5/16 lock washers and (2) 5/16 washers (Fig. 10).
2. Secure fuel tank left side to frame with (2) 5/16–18 x 7/8 in. (22.5 mm) studs, (2) 5/16 washers and (2) 5/16 locknuts (Fig. 10).

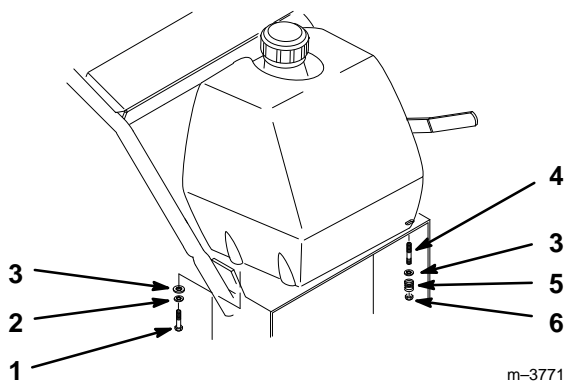
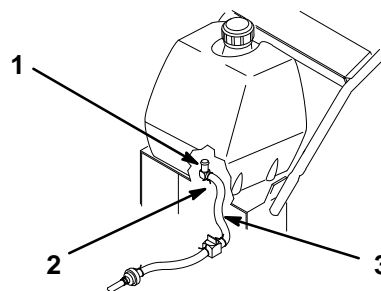

Figure 10

- | | |
|---------------------------------|------------|
| 1. Bolt 5/8–18 x 7/8" (22.5 mm) | 4. Stud |
| 2. Lock washer 5/16 | 5. Spring |
| 3. Washer 5/16 | 6. Locknut |

3. Push fuel line onto fuel tank fitting and secure with hose clamp (Fig. 11).



m-3778

Figure 11

- | | |
|---------------|-----------------|
| 1. Fuel line | 3. Fuel fitting |
| 2. Hose clamp | |

Operation

Think Safety First

Please carefully read all the safety instructions and symbols in the safety section. Knowing this information could help you, pets or bystanders avoid injury.

Controls

Become familiar with all the controls (Fig. 12) before you start the engine and operate the machine.

Throttle Control – The throttle control has CHOKE, FAST, SLOW and STOP positions.

Bail – The bail, in conjunction with the PTO switch, allows the engine to be started with the PTO disengaged. With the bail compressed the blade control (PTO) can be engaged. Release the bail with the PTO engaged and the engine stops.

Blade Control (PTO) – The blade control lever (PTO) engages and disengages power to the mower blades. Move the PTO lever forward to engage the blades. Pull rearward to stop driving mower blades

Gear Shift Lever – Transmission has five forward speeds, neutral and reverse, and has an in-line shift pattern. Do not shift while unit is moving, as transmission damage may occur.

Upper Control Bar – Shift to desired gear and push forward on control bar to engage forward traction operation and pull back to brake. Pull right side of control bar to turn right and left side to turn left.

Lower Control Bar – Shift transmission to reverse and pull rearward on lower control bar to engage rearward traction operation.

Parking Brake Lever – Pull back on upper control bar and swing brake lever up against the upper handle to keep brake engaged.

Recoil Starter – Pull recoil starter handle to start engine.

Fuel Shut-off Valve – (In fuel line) Close fuel shut-off valve when transporting or storing mower.

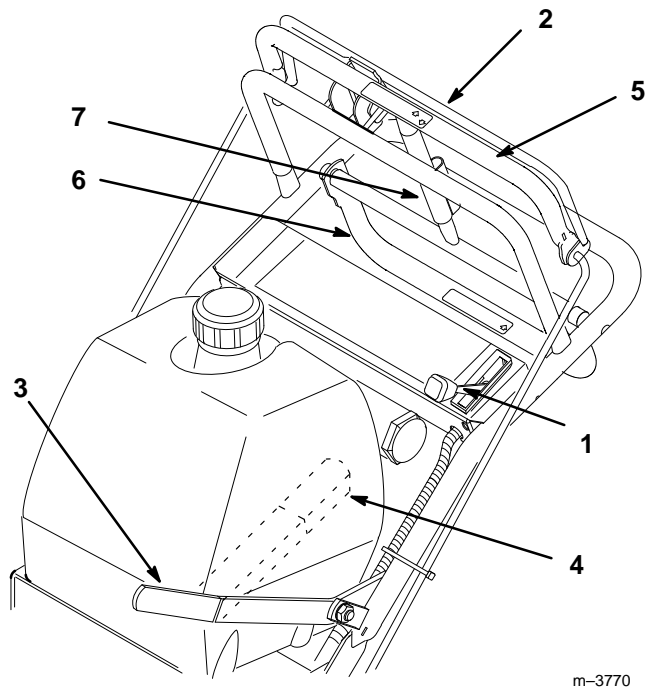

m-3770

Figure 12

- | | |
|------------------------|------------------------|
| 1. Throttle control | 5. Upper control bar |
| 2. Bail | 6. Lower control bar |
| 3. Blade control (PTO) | 7. Parking brake lever |
| 4. Gear shift lever | |

Parking Brake

Always set the parking brake when you stop the machine or leave it unattended.

Setting the Parking Brake

1. Pull the upper control bar rearward and hold it in this position (Fig. 13).
2. Lift the parking brake lock up and gradually release the upper control bar (Fig. 13). The brake lock should stay in the set (locked) position.

Releasing the Parking Brake

1. Pull rearward on the upper control bar (Fig. 13). Lower the parking brake lock to the released position.
2. Gradually release the upper control bar.

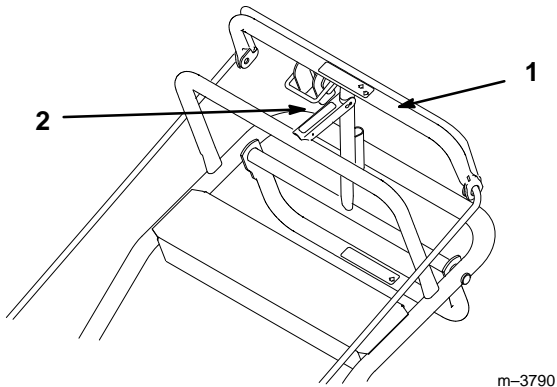

Figure 13

1. Upper control bar
2. Parking brake lock

Starting and Stopping the Engine

Starting

1. Make sure spark plug wire(s) are installed on spark plug(s) and fuel valve is open.
2. Move the blade control to off, the shift lever to neutral and set the parking.
3. Move the throttle control to CHOKE position before starting a cold engine.

Note: A warm or hot engine usually does not require any choking. To start a warm engine, move throttle control to FAST position.

4. Grasp recoil starter handle firmly and pull out until positive engagement results; then pull handle vigorously to start engine. Allow rope to recoil slowly.

IMPORTANT: Do not pull recoil rope to its limit or let go of the starter handle when rope is pulled out because rope may break or recoil assembly may be damaged.

Stopping

1. Move the throttle lever to “SLOW” (Fig. 14).

Note: If the engine has been working hard or is hot, let it idle for a minute before stopping. This helps cool the engine. In an emergency, the engine may be stopped by pulling the throttle all the way back, past SLOW.

2. To stop the engine pull the throttle all the way back, past SLOW(Fig. 14).

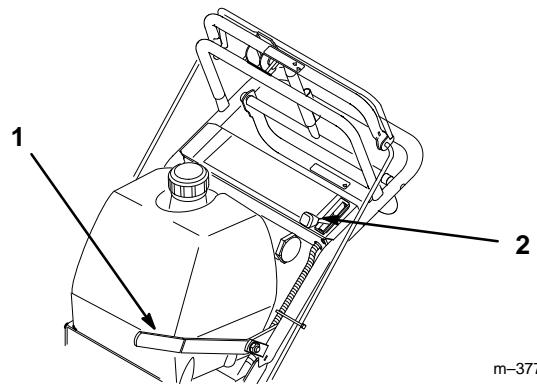

m-3770

Figure 14

1. Blade control (PTO)
 2. Throttle lever
-

3. Set the parking brake.
4. Pull wire off spark plug(s) to prevent possibility of accidental starting before storing machine.
5. Close fuel shut off valve before storing machine.

IMPORTANT: Make sure fuel shut off valve is closed before transporting or storing machine, or fuel leakage may occur.

Operating Blade Control (PTO)

The blade control (PTO) lever engages and disengages power to the mower blades.

Engaging the Mower Blades (PTO)

1. Pull on the upper control bar to stop the machine (Fig. 15).
2. Hold the bail against the upper control bar (Fig. 15).
3. To engage blade(s), push the blade control lever firmly forward, until it latches going over-center (Fig. 15).

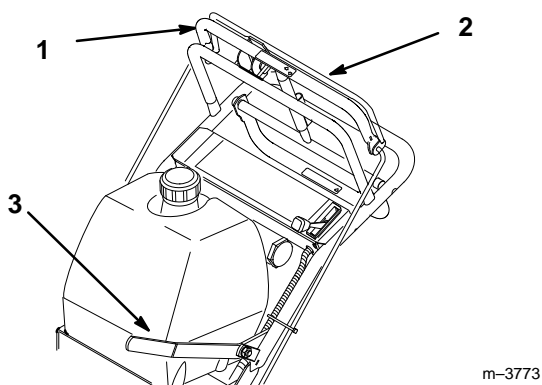

Figure 15

- | | |
|----------------------|------------------------|
| 1. Upper control bar | 3. Blade control (PTO) |
| 2. Bail | |

Disengaging the Mower Blades (PTO)

1. To disengage the blade(s), pull blade control lever rearward, all the way (Fig. 15).

The Safety Interlock System

Understanding the Safety Interlock System

The safety interlock system is designed to prevent the engine from starting if:

- The throttle lever is all the way back, past SLOW
- The blade control lever (PTO) is engaged

The safety interlock system is also designed to stop the engine if you released the bail with the PTO engaged or move the throttle all the way back, past SLOW.

Testing the Safety Interlock System

Test the safety interlock system before you use the machine each time. If the safety system does not operate as described below, have an Authorized Service Dealer repair the safety system immediately.

1. Set the parking brake, disengage the PTO and place the throttle forward. Start the engine. With the engine running squeeze the bail against upper control bar and push the mower blade control lever forward. The mower blades begin rotating.
2. With the engine running, release the bail. The engine should stop.
3. Start the engine again.
4. With the engine running, move the throttle lever is all the way back, past SLOW. The engine should stop.

Driving Forward or Backward

The throttle control regulates the engine speed as measured in rpm (revolutions per minute). Place the throttle control in the “FAST” position for best performance.

Forward

1. To go forward, move the shift lever to a forward gear.
2. Release the parking brake: refer to Releasing the Parking Brake, page 17.
3. Slowly press on the upper control bar to move forward (Fig. 16).

To go straight, apply equal pressure to both ends of the upper control bar (Fig. 16).

To turn, release pressure on the upper control bar side toward the direction you want to turn (Fig. 16).

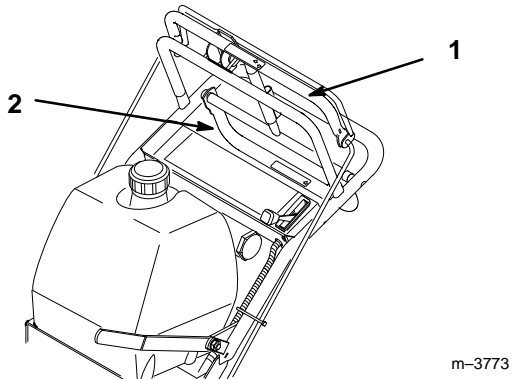

Figure 16

1. Upper control bar 2. Lower control bar

Backward

1. To go backward, move the shift lever to reverse gear.
2. Release the parking brake: refer to Releasing the Parking Brake, page 17.
3. Slowly pull on the lower control bar to move rearward (Fig. 16).

Stopping the Machine

To stop the machine apply the brakes, pull back on the upper control bar, release the bail and set the parking brake; refer to Setting the Parking Brake, page 17.

Adjusting Height-of-Cut

A 1" to 4-1/4" range for height-of-cut can be achieved by adjusting blade spacers, rear axle height and front castor spacers. Use the Height-of-Cut chart on page 22 to select the combination required

Adjust Blade Height

Blades are adjusted by using the four, 1/4" spacers found on the blade spindle bolts. This allows a range, in 1/4" increments, of cutting height in any axle position. The same number of blade spacers must be used on all blades to achieve a level cut (two above and two below, one above and three below, etc.).

1. Stop engine and remove spark plug wire(s).
2. Hold blade bolt and remove nut. Slide bolt down, through spindle, and change spacers as required (Fig. 17).
3. Insert bolt, add extra spacer(s), and secure with thin washer and nut (Fig. 17).
4. Torque blade bolt to 75–80 ft. lb. (101–108 N•m).

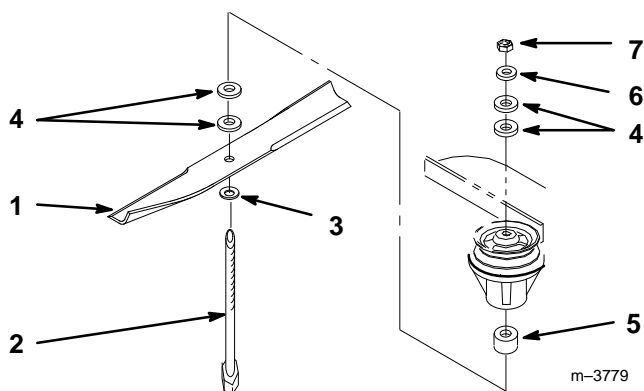

Figure 17

- | | |
|----------------|----------------|
| 1. Blade | 5. Tube |
| 2. Blade bolt | 6. Thin washer |
| 3. Cone washer | 7. Nut |
| 4. Spacer | |

Adjust Axle Height

Desired height-of-cut range can be obtained by adjusting the rear axle and placing caster spacers above or below the caster arm (see chart).

1. Stop engine and remove spark plug wire(s).
2. Loosen but do not remove the (2) axle pivot bolts and the (2) axle adjustment bolts (Fig. 18).
3. Place a jack under the rear center of the engine frame. Raise the back end of the engine frame up enough to remove front (2) axle adjustment bolts (Fig. 18).
4. Raise or lower the engine frame with the jack, so that front (2) axle adjustment bolts can be installed in the desired hole location (Fig. 18). A tapered punch can be used to help align the holes.
5. Tighten all (4) bolts and lower the unit.
6. Adjust control rods and brake linkages as required, refer to: Assembly and Brake.

IMPORTANT: It will be necessary to adjust control rods and brake linkage when changing axle positions for proper traction and brake function.

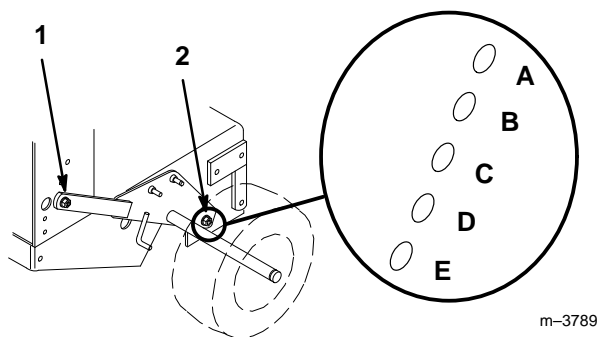
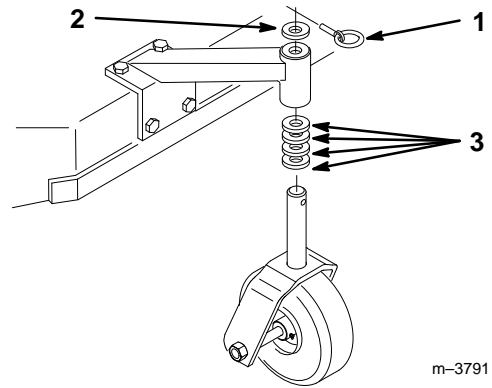

Figure 18

- | | |
|--------------------|-------------------------|
| 1. Axle pivot bolt | 2. Axle adjustment bolt |
|--------------------|-------------------------|

Adjust Caster Position

1. Using the height-of-cut chart, adjust the caster spacers to match with the axle hole selected (Fig. 19).
2. Remove clevis pin, slide caster from support and change spacers(Fig. 19).
3. Install caster in support and insert clevis pin(Fig. 19).



m-3791

Figure 19

1. Clevis pin
2. 3/16" (5 mm) spacer
3. 1/2" (13 mm) spacer

Height-of-Cut Chart

Axle Position	No. of Spacers Below Caster		Number of 1/4" Blade Spacers Below Spindle				
	1/2"	3/16"	4	3	2	1	0
A	0	0	1"	1-1/4"	1-1/2"	1-3/4"	2"
A	0	1	1-1/8"	1-3/8"	1-5/8"	1-7/8"	2-1/8"
A	1	0	1-3/8"	1-5/8"	1-7/8"	2-1/8"	2-3/8"
B	0	1	1-3/8"	1-5/8"	1-7/8"	2-1/8"	2-3/8"
B	1	0	1-5/8"	1-7/8"	2-1/8"	2-3/8"	2-5/8"
B	1	1	1-3/4"	2"	2-1/4"	2-1/2"	2-3/4"
B	2	0	2"	2-1/4"	2-1/2"	2-3/4"	3"
C	1	1	1-7/8"	2-1/8"	2-3/8"	2-5/8"	2-7/8"
C	2	0	2-1/8"	2-3/8"	2-5/8"	2-7/8"	3-1/8"
C	2	1	2-1/4"	2-1/2"	2-3/4"	3"	3-1/4"
C	3	0	2-1/2"	2-3/4"	3"	3-1/4"	3-1/2"
D	2	1	2-3/8"	2-5/8"	2-7/8"	3-1/8"	3-3/8"
D	3	0	2-1/2"	2-3/4"	3"	3-1/4"	3-1/2"
D	3	1	2-3/4"	3"	3-1/4"	3-1/2"	3-3/4"
D	4	0	3"	3-1/4"	3-1/2"	3-3/4"	4"
E	3	1	2-7/8"	3-1/8"	3-3/8"	3-5/8"	3-7/8"
E	4	0	3-1/8"	3-3/8"	3-5/8"	3-7/8"	4-1/8"
E	4	1	3-1/4"	3-1/2"	3-3/4"	4"	4-1/4"

Maintenance

Service Interval Chart

Service Operation	Each Use	8 Hours	25 Hours	50 Hours	100 Hours	200 Hours	Storage Service
Oil—check level	X						X
Oil—change*		Initial			X		X
Oil Filter—change (200 hours or every other oil change)						X	X
Safety System—check	X						X
Brakes—check	X						X
Cutting Blades – check		X			X		X
Wheel Bearings—grease*		X					X
All other fittings – grease			X				X
Foam Air Cleaner—service*			X				X
Paper Air Cleaner—replace*					X		X
Spark Plug(s)—check						X	X
Belts—check for wear/cracks				X			X
PTO Belt—check tension		Initial		X			X
Gasoline—drain							X
Engine—clean cooling system	X				X		X
Fuel Filter—replace						X	X
Tires—check pressure				X			X
Chipped Surfaces—paint							X
* More often in dusty, dirty conditions							

Air Cleaner

Service Interval/Specification

Foam Element: Clean and re-oil after every 25 operating hours.

Paper Element: Replace after every 100 operating hours.

Note: Service the air cleaner more frequently (every few hours) if operating conditions are extremely dusty or sandy.

Removing the Foam and Paper Elements

1. Disengage the power take off (PTO), set the parking brake, and turn the ignition key to "OFF" to stop the engine. Remove the key.
2. Clean around the air cleaner to prevent dirt from getting into the engine and causing damage. Unscrew the cover nuts and remove the air cleaner cover (Fig. 20).
3. Remove the air cleaner assembly (Fig. 20).
4. Carefully slide the foam element off the paper element (Fig. 20).

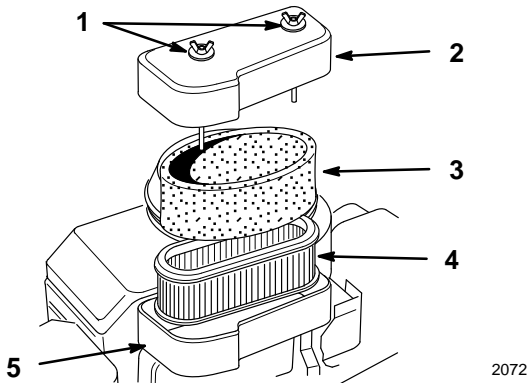

Figure 20

- | | |
|----------------------|---------------------|
| 1. Cover nut | 4. Paper element |
| 2. Air cleaner cover | 5. Air cleaner base |
| 3. Foam element | |

Cleaning the Foam and Paper Elements

1. Foam Element
 - A. Wash the foam element in liquid soap and warm water. When the element is clean, rinse it thoroughly.
 - B. Dry the element by squeezing it in a clean cloth.
 - C. Put one or two ounces of oil on the element (Fig. 21). Squeeze the element to distribute the oil.

IMPORTANT: Replace the foam element if it is torn or worn.

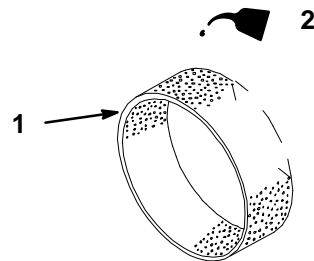

Figure 21

- | | |
|-----------------|--------|
| 1. Foam element | 2. Oil |
|-----------------|--------|

m-1213

2. Paper Element

- A. Lightly tap the element on a flat surface to remove dust and dirt (Fig. 22).
- B. Inspect the element for tears, an oily film, and damage to the rubber seal.

IMPORTANT: Never clean the paper element with pressurized air or liquids, such as solvent, gas, or kerosene. Replace the paper element if it is damaged, defective, or cannot be cleaned thoroughly.

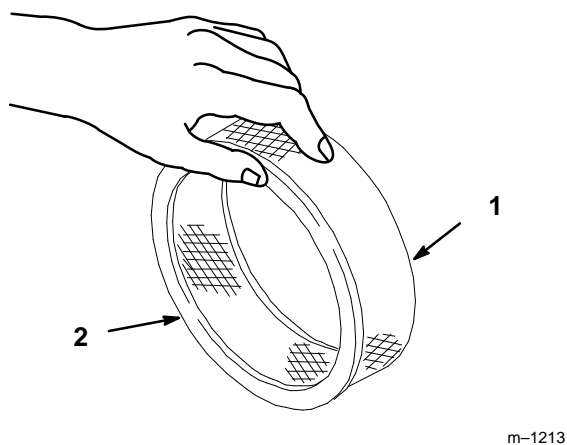

Figure 22

1. Paper element
2. Rubber seal

Installing the Foam and Paper Elements

1. Installing the Foam and Paper Elements

IMPORTANT: To prevent engine damage, always operate the engine with the complete foam and paper air cleaner assembly installed.

1. Carefully slide the foam element onto the paper air cleaner element (Fig. 20).
2. Place the air cleaner assembly onto the air cleaner base (Fig. 20).
3. Install the air cleaner cover and secure with cover nuts (Fig. 20).

Engine Oil

Service Interval/Specification

Change oil:

- After the first 8 operating hours.
- After every 100 operating hours.

Note: Change oil more frequently when operating conditions are extremely dusty or sandy.

Oil Type: Detergent oil (API service SC, SD, SE, SF, SG or SH)

Crankcase Capacity: w/filter, 54 oz. (1.6 l)

Viscosity: See table below

USE THESE SAE VISCOSITY OILS

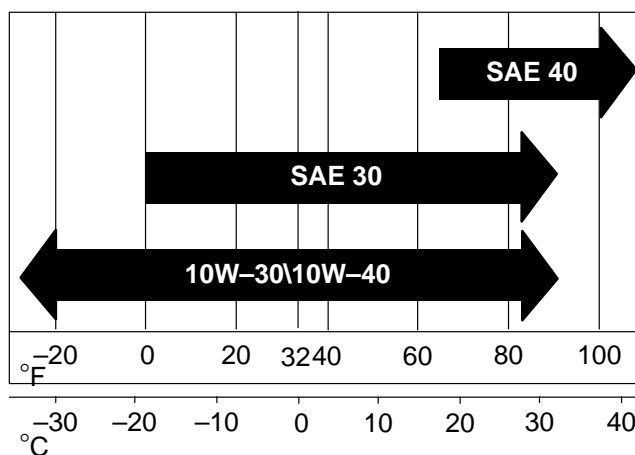

Checking Oil Level

1. Park the machine on a level surface, disengage the power take off (PTO), set the parking brake, and turn the ignition key to “OFF” to stop the engine. Remove the key.
2. Clean around the oil dipstick (Fig. 23) so dirt cannot fall into the filler hole and damage the engine.
3. Unscrew the oil dipstick and wipe the metal end clean (Fig. 23).
4. Slide the oil dipstick fully into the filler tube, do not thread onto tube (Fig. 23). Pull the dipstick out and look at the metal end. If oil level is low, slowly pour only enough oil into the filler tube to raise the level to the “FULL” mark.

IMPORTANT: Do not overfill the crankcase with oil because the engine may be damaged.

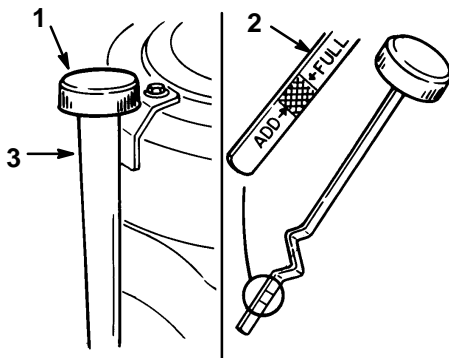

Figure 23

1. Oil dipstick
2. Metal end
3. Filler tube

Changing/Draining Oil

1. Start the engine and let it run five minutes. This warms the oil so it drains better.
2. Park the machine so that the drain side is slightly lower than the opposite side to assure the oil drains completely. Then disengage the power take off (PTO), set the parking brake, and turn the ignition key to “OFF” to stop the engine. Remove the key.
3. Place a pan below the oil drain. Remove the oil drain plug (Fig. 24).
4. When oil has drained completely, install the oil drain plug.

Note: Dispose of the used oil at a certified recycling center.

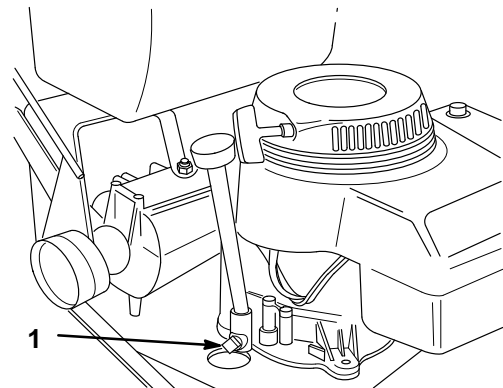

m-2068

Figure 24

1. Oil drain plug

5. Slowly pour approximately 80% of the specified amount of oil specified, page 25, into the filler tube (Fig. 23). Now check the oil level; refer to Checking Oil Level, page 26. Slowly add additional oil to bring to “FULL” mark on dipstick.

Change Oil Filter

Service Interval/Specification

Replace the oil filter every 200 hours or every other oil change.

Note: Change oil filter more frequently when operating conditions are extremely dusty or sandy.

1. Drain the oil from the engine; refer to Changing/Draining Oil, page 26.
2. Remove the old filter and wipe the filter adapter (Fig. 25) gasket surface.
3. Apply a thin coat of new oil to the rubber gasket on the replacement filter (Fig. 25).

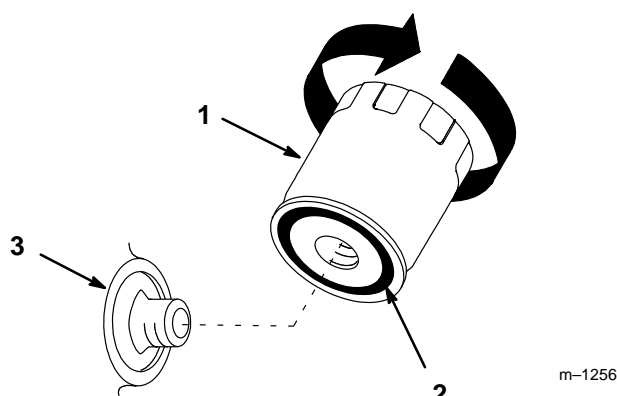

Figure 25

1. Oil filter
2. Gasket
3. Adapter

4. Install the replacement oil filter to the filter adapter. Turn the oil filter clockwise until the rubber gasket contacts the filter adapter, then tighten the filter an additional 3/4 turn (Fig. 25).
5. Fill the crankcase with the proper type of new oil; refer to Changing/Draining Oil, page 26.

Spark Plug

Service Interval/Specification

Check the spark plug(s) after every 200 operating hours. Make sure the air gap between the center and side electrodes is correct before installing the spark plug. Use a spark plug wrench for removing and installing the spark plug(s) and a gapping tool/feeler gauge to check and adjust the air gap. Install a new spark plug(s) if necessary.

Type: Champion RCJ-8
(or equivalent) Air Gap: 0.025 in. (0.65 mm)

Removing the Spark Plug(s)

1. Disengage the power take off (PTO), set the parking brake, and turn the ignition key to "OFF" to stop the engine. Remove the key.
2. Pull the wire(s) off the spark plug(s) (Fig. 26). Now clean around the spark plug(s) to prevent dirt from falling into the engine and potentially causing damage.
3. Remove the spark plug(s) and metal washer.

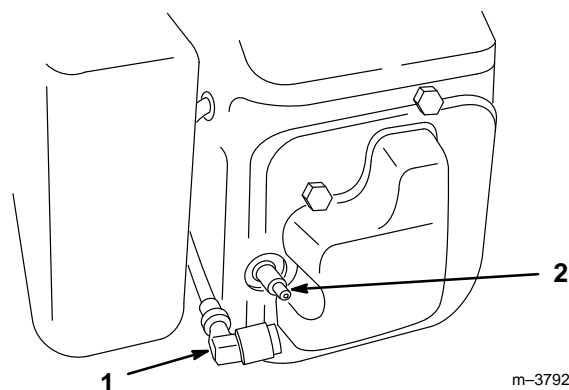

Figure 26

1. Spark plug wire
2. Spark plug

Checking the Spark Plug

1. Look at the center of the spark plug(s) (Fig. 27). If you see light brown or gray on the insulator, the engine is operating properly. A black coating on the insulator usually means the air cleaner is dirty.

IMPORTANT: Never clean the spark plug(s). Always replace the spark plug(s) when it has a black coating, worn electrodes, an oily film, or cracks.

2. Check the gap between the center and side electrodes (Fig. 27). Bend the side electrode (Fig. 27) if the gap is not correct.

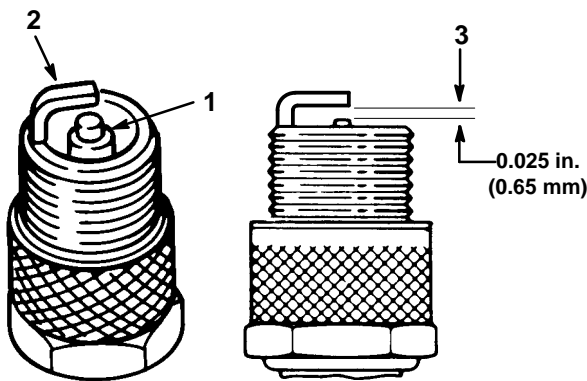

Figure 27

1. Center electrode insulator
2. Side electrode
3. Air gap (not to scale)

Installing the Spark Plug(s)

1. Install the spark plug(s) and metal washer. Make sure the air gap is set correctly.
2. Tighten the spark plug(s) to 18 ft-lb (24 N.m).
3. Push the wire(s) onto the spark plug(s) (Fig. 26).

Cutting Blades

To ensure a superior quality of cut, keep the blades sharp. For convenient sharpening and replacement, you may want to keep extra blades on hand.

WARNING

POTENTIAL HAZARD

- A blade that is worn or damaged could break apart and pieces could be thrown at bystanders or at you as you use the mower.

WHAT CAN HAPPEN

- Pieces of blade that may be thrown could seriously injure or kill you or bystanders.

HOW TO AVOID THE HAZARD

- Periodically inspect the blade for wear and damage. Immediately install a new blade if it is worn or damaged.

Before Inspecting or Servicing the Blades

Park the machine on a level surface, disengage the blade control (PTO) and set the parking brake.

Inspecting the Blades

1. Inspect the cutting edges (Fig 28). If the edges are not sharp or have nicks, remove and sharpen the blades. Refer to Sharpening the Blades on page 30.
2. Inspect the blades, especially the curved area (Fig. 28). If you notice any damage, wear, or a slot forming in this area (item 3 in Fig. 28), immediately install a new blade.

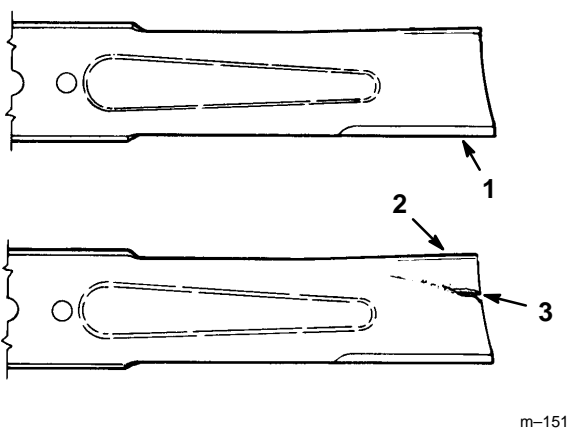

Figure 28

- | | |
|-----------------|----------------------|
| 1. Cutting Edge | 3. Wear/slot Forming |
| 2. Curved Area | |

Checking for Bent Blades

1. Rotate the blades until the ends face forward and backward (Fig. 29). Measure from a level surface to the cutting edge of the blades (Fig. 30). Note this dimension.

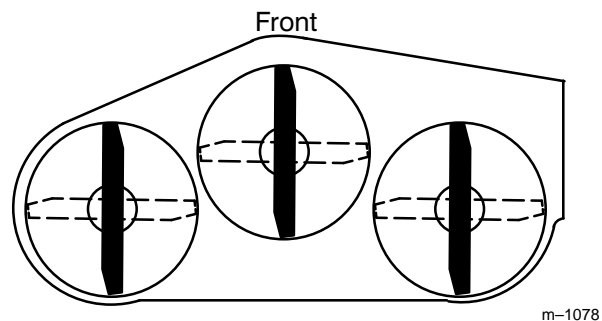

Figure 29

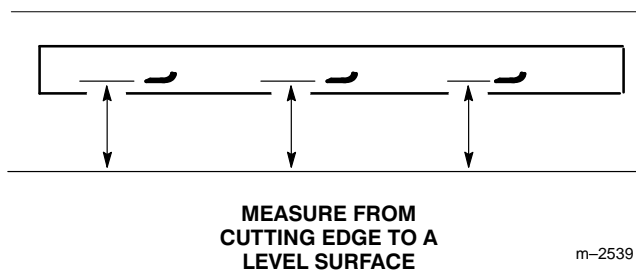

Figure 30

2. Rotate the opposite ends of the blades forward. Measure from a level surface to the cutting edge of the blades at the same position as in step 1 above. The difference between the dimensions obtained in steps 1 and 2 must not exceed 1/8" (3 mm). If this dimension exceeds 1/8" (3 mm), the blade is bent and must be replaced. Refer to Removing the Blades, and Installing the Blades on page 30.

! WARNING

POTENTIAL HAZARD

- A blade that is bent or damaged could break apart and pieces could be thrown at bystanders or at you as you use the mower.

WHAT CAN HAPPEN

- Pieces of blade that may be thrown could seriously injure or kill you or bystanders.

HOW TO AVOID THE HAZARD

- Always replace bent or damaged blade with a new blade.
- Never file or create sharp notches in the edges or surfaces of blade.

Removing the Blades

Blades must be replaced if a solid object is hit, if the blade is out of balance or is bent. To ensure optimum performance and continued safety conformance of the machine, use genuine TORO replacement blades. Replacement blades made by other manufacturers may result in non-conformance with safety standards.

Hold the blade bolt with a wrench. Remove the nut, blade bolt, cone washer, blade, spacers and thin washer from the spindle (Fig. 31).

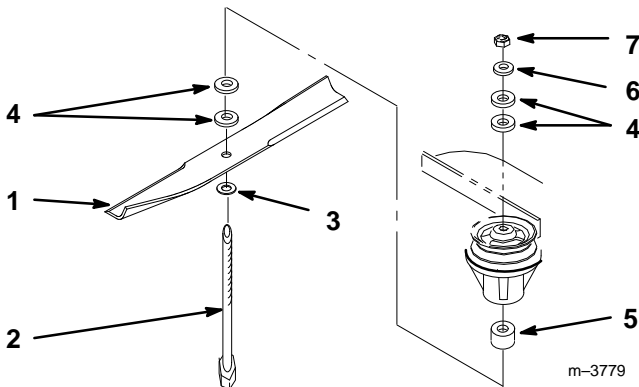

Figure 31

- | | |
|----------------|----------------|
| 1. Blade | 5. Tube |
| 2. Blade bolt | 6. Thin washer |
| 3. Cone washer | 7. Nut |
| 4. Spacer | |

Sharpening the Blades

1. Use a file to sharpen the cutting edge at both ends of the blade (Fig. 32). Maintain the original angle. The blade retains its balance if the same amount of material is removed from both cutting edges.

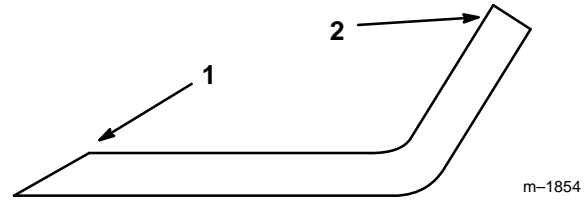

Figure 32

1. Sharpen at original angle
2. Sail

2. Check the balance of the blade by putting it on a blade balancer (Fig. 33). If the blade stays in a horizontal position, the blade is balanced and can be used. If the blade is not balanced, file some metal off the end of the sail area only (Fig. 32). Repeat this procedure until the blade is balanced.

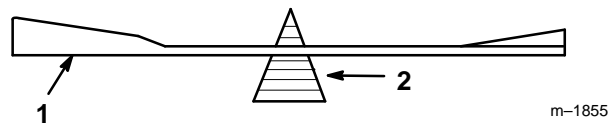

Figure 33

1. Blade
2. Balancer

Installing the Blades

1. Place the blade onto the bolt, over cone washer. Select proper number of spacer(s) for height-of-cut and slide bolt into spindle (Fig. 31).

IMPORTANT: The curved part of the blade must be pointing upward toward the inside of the mower to ensure proper cutting.

2. Install remaining spacer(s) and secure with thin washer and nut (Fig. 31).
3. Torque the blade bolt to 75–80 ft. lb. (101–108 N•m).

Adjusting Blade Brake

Before each use, check blade brake for proper operation.

The blade brake must be adjusted to stop the blade(s) when the blade control (PTO) lever is disengaged.

1. To adjust the blade brake, engage the blade control (PTO) lever.
2. Loosen nut at the brake spring so pad rubs against pulley. Then tighten nut until pad just clears the pulley (Fig. 34).
3. Disengage blade control (PTO) lever. Brake rod(s) must be loose (Fig. 34).
4. Both conditions must be achieved for proper adjustment.

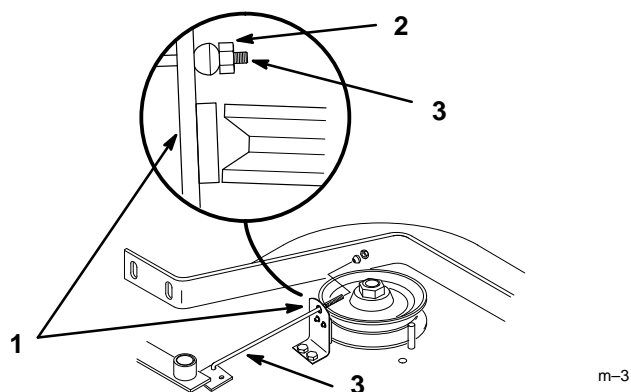

Figure 34

- | | |
|-----------------|--------|
| 1. Brake spring | 3. Rod |
| 2. Nut | |

m-3

Tire Pressure

Service Interval/Specification

Maintain the air pressure in the front and rear tires as specified. Check the pressure at the valve stem after every 50 operating hours or monthly, whichever occurs first (Fig. 35). Check the tires when they are cold to get the most accurate pressure reading.

Pressure: 15 psi (.103 kPa) rear and castor tires

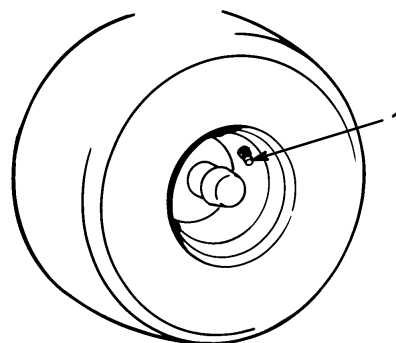

Figure 35

1. Valve stem

Cleaning the Cooling System

Service Interval/Specification

Before each use, check and clean engine cooling system. Remove any build-up of grass, dirt or other debris from the cylinder and cylinder head cooling fins, air intake screen on flywheel end, and carburetor-governor levers and linkage. This will help insure adequate cooling and correct engine speed and will reduce the possibility of overheating and mechanical damage to the engine.

Greasing and Lubrication

Service Interval/Specification

Grease the wheel bearings every 8 operating hours and all other grease fittings 25 operating hours. Grease more frequently when operating conditions are extremely dusty or sandy.

Grease Type: General-purpose grease.

How to Grease

1. Disengage the blade control (PTO) and set the parking brake.
2. Clean the grease fittings with a rag. Make sure to scrape any paint off the front of the fitting(s).
3. Connect a grease gun to the fitting. Pump grease into the fittings until grease begins to ooze out of the bearings.
4. Wipe up any excess grease.

Where to Add Grease

1. Lubricate the drive and castor wheel bearings and front spindles (Fig. 36).

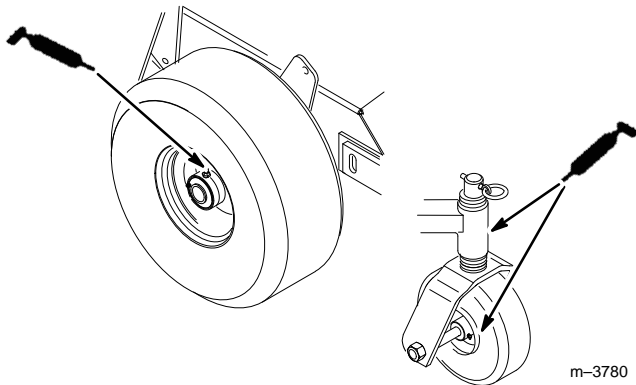

Figure 36

2. Lubricate the transmission couplers and idler arm pivots (Fig. 37).

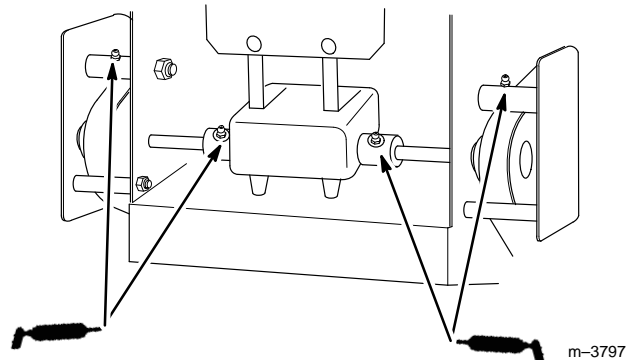

Figure 37

3. Lubricate the blade belt idler arm pivots and blade spindles (Fig. 38).

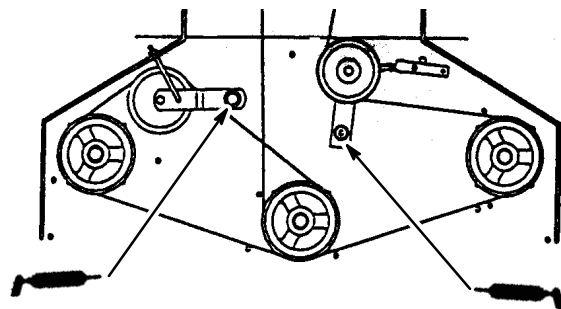

Figure 38

Brake

Service Interval/Specification

Before each use, check brakes for proper operation.

Always set the parking brake when you stop the machine or leave it unattended. If the parking brake does not hold securely, an adjustment is required.

Checking the Brake

1. Park the machine on a level surface, disengage the blade control (PTO) and set the parking brake.
2. Rear wheels must lock when you try to push the machine forward or backward. Adjustment is required if the wheels turn and do not lock; refer to Adjusting the Brake, page 33.
3. Release the brake and press upper control bar very lightly, approximately 1/2 in. (13 mm), wheels should rotate freely.
4. If both conditions are met no adjustment is required.

Adjusting the Brake

The brake lever is on the upper control bar (Fig. 12). If the parking brake does not hold securely, an adjustment is required.

1. Check the brake before you adjust it; refer to Checking the Brake, page 33.
2. Release the parking brake; refer to Releasing the Parking Brake, page 17.
3. To adjust brake set the parking brake latch, and rotate the wing nuts on the brake rods (Fig. 39). Clockwise to tighten the brake and counterclockwise to loosen the brake.

Note: Control bar should be parallel with reference bar when properly adjusted.

4. Check the brake operation again; refer to Checking the Brake, page 33.

IMPORTANT: With the parking brake released, the rear wheels must rotate freely when you push the mower. If brake action and free wheel rotation cannot be achieved contact your service dealer immediately.

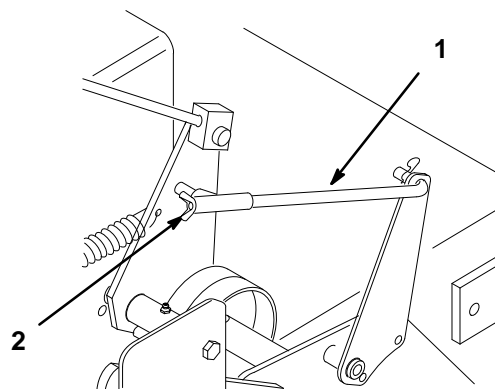

m-3773

Figure 39

1. Brake rod
2. Wing nut

Fuel Tank

Draining The Fuel Tank

DANGER

POTENTIAL HAZARD

- In certain conditions gasoline is extremely flammable and highly explosive.

WHAT CAN HAPPEN

- A fire or explosion from gasoline can burn you, others, and cause property damage.

HOW TO AVOID THE HAZARD

- Drain gasoline from the fuel tank when the engine is cold. Do this outdoors in an open area. Wipe up any gasoline that spills.
- Never drain gasoline near an open flame or where gasoline fumes may be ignited by a spark.
- Never smoke a cigarette, cigar or pipe.

1. Park the machine on a level surface, to assure fuel tank drains completely. Then disengage the blade control (PTO) and set the parking brake.
2. Close the fuel shut-off valve in fuel line (Fig. 40).
3. Squeeze the ends of the hose clamp together and slide it up the fuel line away from fuel filter (Fig. 40).

4. Pull the fuel line off the fuel filter (Fig. 40). Open fuel shut-off valve and allow gasoline to drain into a gas can or drain pan.

Note: Now is the best time to install a new fuel filter because the fuel tank is empty. Refer to Replacing the Fuel Filter; page 35.

5. Install the fuel line onto the fuel filter. Slide the hose clamp close to the filter to secure the fuel line.

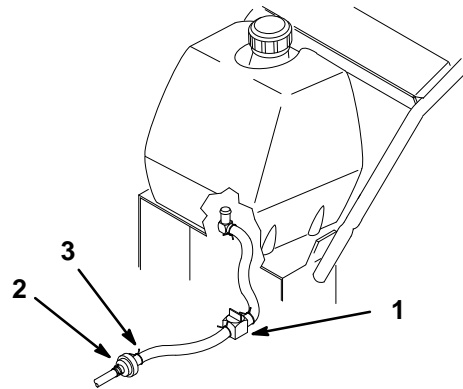

m-3778

Figure 40

1. Fuel shut-off valve
2. Fuel filter
3. Clamp

Fuel Filter

Service Interval/Specification

Replace the fuel filter after every 200 operating hours or yearly, whichever occurs first.

Replacing the Fuel Filter

Never install a dirty filter if it is removed from the fuel line.

1. Disengage the blade control (PTO) and set the parking brake. Stop engine.
2. Close fuel shut-off valve (Fig. 40).
3. Squeeze the ends of the hose clamps together and slide them away from the filter (Fig. 41).
4. Remove the filter from the fuel lines.
5. Install a new filter and move the hose clamps close to the filter.
6. Open fuel shut-off valve at fuel tank (Fig. 40).

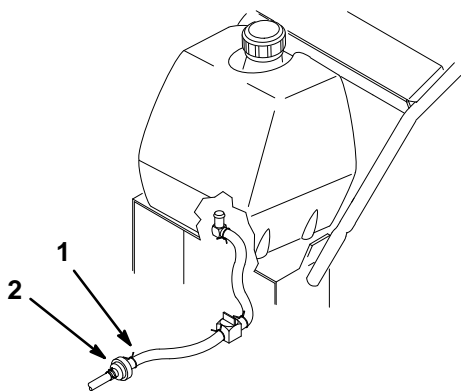

m-3778

Figure 41

1. Hose clamp 2. Filter

Replacing the Wheel Belt

Service Interval/Specification

Check all belts after every 50 operating hours or monthly, whichever occurs first. Look for dirt, wear, cracks and signs of overheating.

1. Remove hairpin cotter securing brake rod to brake arm to relax belt idler tension (Fig. 42).
2. Remove bottom and loosen top bolts of shield to rotate for belt clearance (Fig. 42).
3. Lift belt past idler and off drive pulley (Fig. 42).
4. Raise wheel off ground enough to allow belt removal.

Note: Ensure that the mud and grass scraper is adjusted properly and centered in the pulley grooves. The pointed part of the scraper should be centered and as deep in the pulley groove as possible, without rubbing at any point.

5. Replace drive belt and install brake rod clevis with E-ring (Fig. 42).

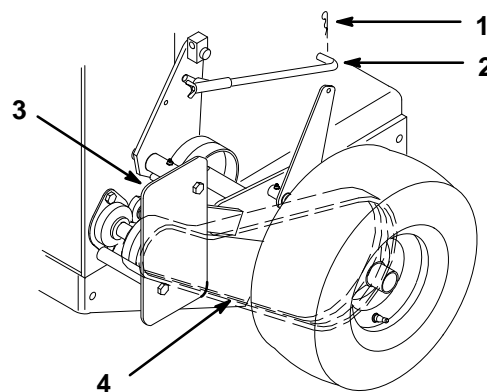

m-3793

Figure 42

1. Hairpin cotter 3. Shield
2. Brake rod 4. Drive belt

Replacing the Traction Belt

1. Stop the engine, set the parking brake and remove the spark plug wire(s).
2. Raise the rear of the machine and hold with jack stands.
3. Remove mower belt (Fig. 44).
4. Loosen pivot bolt enough to slide idler pulley in slot and remove traction belt from the engine and drive pulleys.
5. Install new belt around engine and drive pulleys (Fig. 43).
6. Slide idler pulley in engine frame to tension traction belt (Fig. 43).
7. Install the mower belt (Fig. 44).
8. Check the belt guides under the engine frame for proper adjustment (Fig. 43). Adjust as necessary. The disengaged belt should not drag or fall off pulley when guides are properly adjusted.

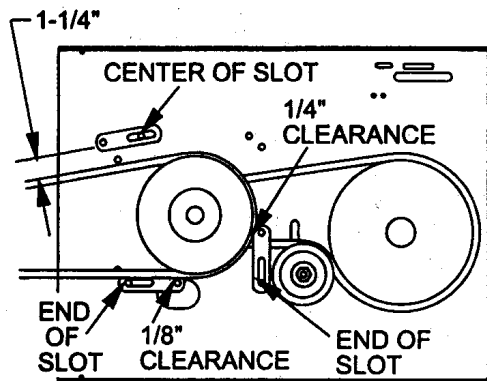

Figure 43

Replacing the Mower Belts

Service Interval/Specification

Check belt tension after the first hour of operation and at least twice during the first 24 hours of operation. Belt must be tight enough to not slip during heavy loads while cutting grass. Over tensioning will reduce belt and spindle bearing life.

1. Stop the engine, set the parking brake and remove the spark plug wire(s).
2. Remove the knobs and belt cover atop mower.
3. Loosen locknut and turnbuckle on idler arm. Remove worn belt (Fig. 44).
4. Install new belt and adjust belt tension, loosen the 5/16" locknut on turnbuckle and rotate the turnbuckle toward the rear of mower to tighten or toward the front of mower to loosen belt tension (Fig. 44).

Note: Proper belt tension will require about 20 lbs. side pull on belt, halfway between pulleys, to deflect belt 1/2".

5. Check belt guide clearance on the mower belt. The four welded belt guides on the mower should be located 1/8" from the belt. Adjust if necessary.

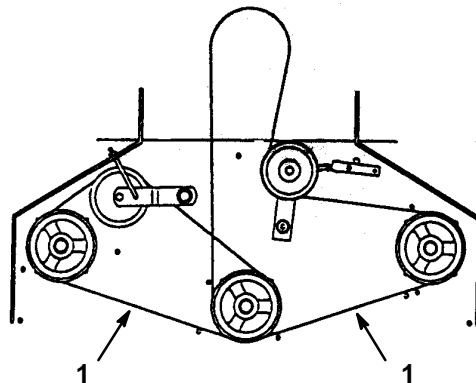

Figure 44

1. 1/2" (13 mm) deflection here

Adjusting Grass\Mud Scraper

1. Loosen the locknut holding scraper to the engine frame (Fig. 45).
2. Rotate scraper until they align with center of pulley grooves (Fig. 45).
3. Tighten the locknut (Fig. 45).

Note: The scraper must not contact the pulley on the sides or bottom of grooves. Re-adjust if necessary.

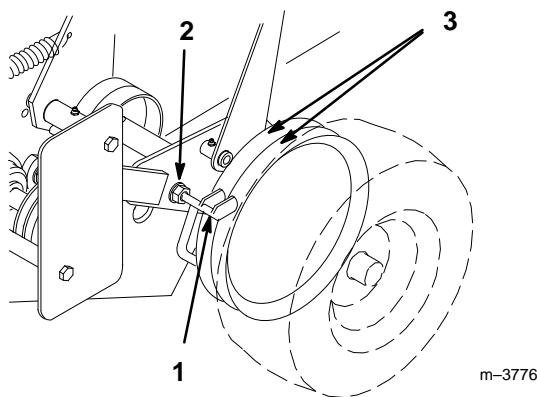

Figure 45

- | | |
|------------|-----------|
| 1. Scraper | 3. Pulley |
| 2. Locknut | |

Replacing the Grass Deflector

1. Remove the locknut, bolt, spring and spacer holding deflector to the mounts (Fig. 46).
2. Straighten deflector mounts if they are bent (Fig. 46).
3. Install new deflector between mounts with spacer and spring. Hook the front end of the spring around the front deflector mount. Insert bolt through spacer and secure with locknut. Confirm there is downward spring force on deflector (Fig. 46).
4. Tighten the bolt and locknut until they lightly contact the pivot brackets (Fig. 46).

IMPORTANT: The grass deflector must be spring-loaded in the down position. Lift the deflector up to test that it snaps to the full down position.

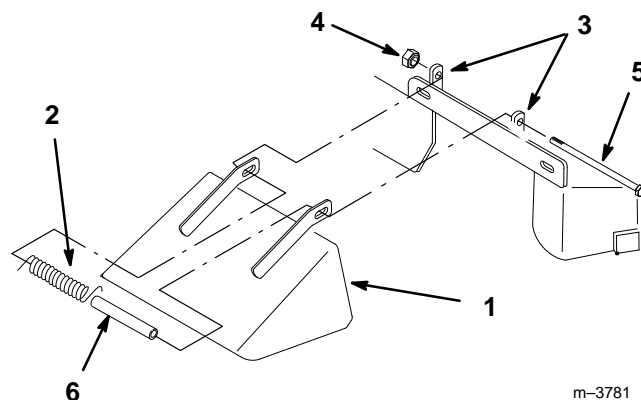
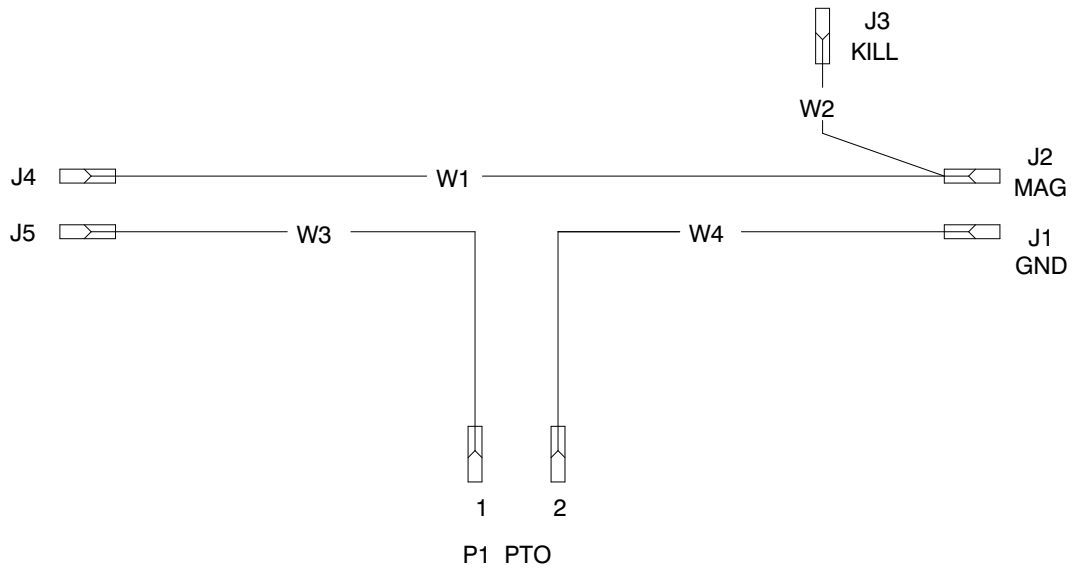

Figure 46

- | | |
|--------------------|------------|
| 1. Deflector | 4. Spring |
| 2. Bolt | 5. Spacer |
| 3. Deflector mount | 6. Locknut |

Wiring Diagram



Cleaning and Storage

1. Disengage the blade control (PTO), set the parking brake, and turn the ignition key to “OFF” to stop the engine. Remove the key.
2. Remove grass clippings, dirt, and grime from the external parts of the entire machine, especially the engine. Clean dirt and chaff from the outside of the engine’s cylinder head fins and blower housing.

IMPORTANT: You can wash the machine with mild detergent and water. Do not pressure wash the machine. Avoid excessive use of water, especially near the control panel, and engine.

3. Check the brake; refer to Brake, page 33.
4. Service the air cleaner; refer to Air Cleaner, page 24.
5. Grease the machine; refer to Greasing and Lubrication, page 32.
6. Change the crankcase oil; refer to Engine Oil, page 25.
7. Remove the spark plug(s) and check its condition; refer to Spark Plug, page 27. With the spark plug(s) removed from the engine, pour two tablespoons of engine oil into the spark plug hole. Now use the starter to crank the engine and distribute the oil inside the cylinder. Install the spark plug(s). Do not install the wire on the spark plug(s).
8. Check the tire pressure; refer to Tire Pressure, page 31.

9. For long-term storage (more than 90 days) add stabilizer/conditioner additive to fuel in the tank (1 oz. per gallon).
 - A. Run engine to distribute conditioned fuel through the fuel system (5 minutes).
 - B. Stop engine, allow to cool and drain the fuel tank; refer to Fuel Tank, page 34, or operate engine until it stops.
 - C. Restart engine and run until it stops. Repeat, on “CHOKE” until engine will not restart.
 - D. Dispose of fuel properly. Recycle as per local codes.

Note: Do not store stabilizer/conditioned gasoline over 90 days.

10. Check and tighten all bolts, nuts, and screws. Repair or replace any part that is damaged or defective.
11. Paint all scratched or bare metal surfaces. Paint is available from your Authorized Service Dealer.
12. Store the machine in a clean, dry garage or storage area. Remove the key from the ignition switch and keep it in a memorable place. Cover the machine to protect it and keep it clean.

Troubleshooting

PROBLEM	POSSIBLE CAUSES	CORRECTIVE ACTION
Engine will not start, starts hard, or fails to keep running.	<ol style="list-style-type: none"> 1. Fuel tank is empty. 2. Choke is not ON. 3. Air cleaner is dirty. 4. Spark plug wire is loose or disconnected. 5. Spark plug is pitted, fouled, or gap is incorrect. 6. Dirt in fuel filter. 7. Dirt, water, or stale fuel is in fuel system. 	<ol style="list-style-type: none"> 1. Fill fuel tank with gasoline. 2. Move choke lever to ON. 3. Clean or replace air cleaner element. 4. Install wire on spark plug. 5. Install new, correctly gapped spark plug. 6. Replace fuel filter. 7. Contact Authorized Service Dealer.
Engine loses power.	<ol style="list-style-type: none"> 1. Engine load is excessive. 2. Air cleaner is dirty. 3. Oil level in crankcase is low. 4. Cooling fins and air passages under engine blower housing are plugged. 5. Spark plug is pitted, fouled, or gap is incorrect. 6. Vent hole in fuel cap is plugged. 7. Dirt in fuel filter. 8. Dirt, water, or stale fuel is in fuel system. 	<ol style="list-style-type: none"> 1. Reduce ground speed. 2. Clean air cleaner element. 3. Add oil to crankcase. 4. Remove obstruction from cooling fins and air passages. 5. Install new, correctly gapped spark plug. 6. Clean or replace the fuel cap. 7. Replace fuel filter. 8. Contact Authorized Service Dealer.
Engine overheats.	<ol style="list-style-type: none"> 1. Engine load is excessive. 2. Oil level in crankcase is low. 3. Cooling fins and air passages under engine blower housing are plugged. 	<ol style="list-style-type: none"> 1. Reduce ground speed. 2. Add oil to crankcase. 3. Remove obstruction from cooling fins and air passages.
Abnormal vibration.	<ol style="list-style-type: none"> 1. Engine mounting bolts are loose. 2. Loose engine pulley, idler pulley, or blade pulley. 3. Engine pulley is damaged. 	<ol style="list-style-type: none"> 1. Tighten engine mounting bolts. 2. Tighten the appropriate pulley. 3. Contact Authorized Service Dealer.

PROBLEM	POSSIBLE CAUSES	CORRECTIVE ACTION
Machine does not drive.	<ol style="list-style-type: none"> 1. Shift lever is in NEUTRAL. 2. Traction belt is worn, loose or broken. 3. Traction belt is off pulley. 	<ol style="list-style-type: none"> 1. Move shift lever to a drive gear position. 2. Change Belt. 3. Change Belt.
Abnormal vibration.	<ol style="list-style-type: none"> 1. Cutting blade(s) is/are bent or unbalanced. 2. Blade mounting bolt is loose. 3. Engine mounting bolts are loose. 4. Loose engine pulley, idler pulley, or blade pulley. 5. Engine pulley is damaged. 6. Blade spindle bent. 	<ol style="list-style-type: none"> 1. Install new cutting blade(s). 2. Tighten blade mounting bolt. 3. Tighten engine mounting bolts. 4. Tighten the appropriate pulley. 5. Contact Authorized Service Dealer. 6. Contact Authorized Service Dealer.
Uneven cutting height.	<ol style="list-style-type: none"> 1. Blade(s) not sharp. 2. Cutting blade(s) is/are bent. 3. Mower is not level. 4. Underside of mower is dirty. 5. Tire pressure is incorrect. 6. Blade spindle bent. 	<ol style="list-style-type: none"> 1. Sharpen blade(s). 2. Install new cutting blade(s). 3. Level mower from side-to-side and front-to-rear. 4. Clean the underside of the mower. 5. Adjust tire pressure. 6. Contact Authorized Service Dealer.
Blades do not rotate.	<ol style="list-style-type: none"> 1. Drive belt is worn, loose or broken. 2. Drive belt is off pulley. 3. Deck belt is worn, loose or broken. 4. Deck belt is off pulley. 	<ol style="list-style-type: none"> 1. Check belt tension. 2. Install drive belt and check adjusting shafts and belt guides for correct position. 3. Install new deck belt. 4. Install deck pulley and check the idler pulley, idler arm and spring for correct position and function.



THE TORO TOTAL COVERAGE GUARANTEE

A One-Year Limited Warranty
(A Two-Year Full Warranty for Residential Use)

What Is Covered By This Express Warranty?

The Toro Company promises to repair any TORO Product used for commercial, institutional, or rental purposes if defective in materials or workmanship for a period of one year from the date of purchase. The cost of parts and labor are included, but the customer pays the transportation cost. Transportation within a 15-mile radius of a TORO ProLine Service Dealer is covered under this warranty for Riding Products, Mid-size Mowers and Turf Maintenance Equipment.

What Products Are Covered By This Warranty?

The following products and their attachments are covered by this warranty:

- Z-Master Zero Radius Tractors
- ProLine Mid-size Mowers
- Groundsmaster Riding Mowers
- ProLine Hand-held Gas Products
- Backpack Blowers
- Commercial WPM
- Turf Maintenance Equipment
- Debris Management Equipment

How About Residential Use?

TORO Products used for residential use are covered by a full two-year warranty.

How Do You Get Warranty Service?

Should you feel your TORO Product contains a defect in materials or workmanship, contact the dealer who sold you the product or any TORO ProLine Service Dealer. The Yellow Pages of your telephone directory is a good reference source; look under TORO Commercial Service Dealers. The Service Dealer will either arrange service at his/her dealership or recommend another authorized Service Dealer who may be more convenient. You may need proof of purchase (copy of registration card, sales receipt, etc.) for warranty validation.

If for any reason you are dissatisfied with a Service Dealer's analysis of the defect in materials or workmanship or if you need a referral to a TORO ProLine Service Dealer, please feel free to contact us at the following address:

Toro Customer Service Department
8111 Lyndale Avenue South
Bloomington, MN 55420-1196
612-888-8801 or 800-348-2424

What Must You Do To Keep The Warranty In Effect?

You must maintain your TORO Product by following the maintenance procedures described in the operator's manual. Such routine maintenance, whether performed by a dealer or by you, is at your expense.

What Does This Warranty Not Cover? and

How Does Your State Law Relate To This Warranty?

There is no other express warranty except for special emission system coverage on some products and as described above. This express warranty does not cover:

- Cost of regular maintenance service or parts, such as filters, fuel, lubricants, tune-up parts, blade sharpening, brake and clutch adjustments.
- Any product or part which has been altered or misused or required replacement or repair due to normal wear, accidents, or lack of proper maintenance.
- Repairs necessary due to improper fuel, contaminants in the fuel system, or failure to properly prepare the fuel system prior to any period of non-use over three months.
- Pickup and delivery charges for distances beyond a 15-mile radius from a TORO ProLine Service Dealer.

All repairs covered by this warranty must be performed by a TORO Service Dealer using Toro approved replacement parts.

The Toro Company is not liable for indirect or consequential damages in connection with the use of the TORO Products covered by this warranty, including any cost or expense of providing substitute equipment or service during reasonable periods of malfunction or non-use pending completion of repairs under this warranty. Some states do not allow exclusions of incidental or consequential damages, so the above exclusion may not apply to you.

This warranty gives you specific legal rights, and you may also have other rights which vary from state to state.

COUNTRIES OTHER THAN THE UNITED STATES OR CANADA

Customers who have purchased TORO products exported from the United States or Canada should contact their TORO Distributor (Dealer) to obtain guarantee policies for your country, province, or state. If for any reason you are dissatisfied with your Distributor's service or have difficulty obtaining guarantee information, contact the TORO importer. If all other remedies fail, you may contact us at The Toro Company.