



**Count on it.**

**Operator's Manual**

**Groundsmaster® 360 2-Wheel Drive, 4-Wheel Drive, or 4-Wheel Drive with Cab Multi-Purpose Machine**

Model No. 31200—Serial No. 40000000 and Up

Model No. 31202—Serial No. 40000000 and Up

Model No. 31203—Serial No. 40000000 and Up



## ⚠ WARNING

### CALIFORNIA Proposition 65 Warning

This product contains a chemical or chemicals known to the State of California to cause cancer, birth defects, or reproductive harm.

Diesel engine exhaust and some of its constituents are known to the State of California to cause cancer, birth defects, and other reproductive harm.

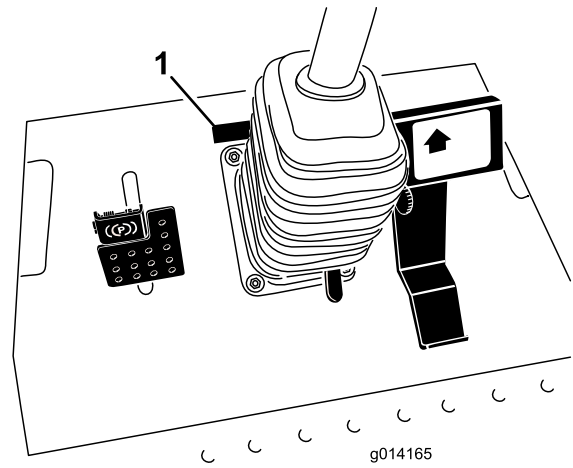

Figure 1

1. Model and serial number location

Model No. \_\_\_\_\_  
Serial No. \_\_\_\_\_

This manual identifies potential hazards and has safety messages identified by the safety-alert symbol (Figure 2), which signals a hazard that may cause serious injury or death if you do not follow the recommended precautions.



Figure 2

1. Safety-alert symbol

This manual also uses 2 words to highlight information. **Important** calls attention to special mechanical information and **Note** emphasizes general information worthy of special attention.

## Introduction

This machine is a ride-on, multi-purpose machine intended to be used by professional, hired operators in commercial applications. It is primarily designed for maintaining grass on well-maintained lawns in parks, sports fields, and on commercial grounds. It is not designed for cutting brush, mowing grass and other growth alongside highways, or for agricultural uses.

Read this information carefully to learn how to operate and maintain your product properly and to avoid injury and product damage. You are responsible for operating the product properly and safely.

You may contact Toro directly at [www.Toro.com](http://www.Toro.com) for product safety and operation training materials, accessory information, help finding a dealer, or to register your product.

Whenever you need service, genuine Toro parts, or additional information, contact an Authorized Service Dealer or Toro Customer Service and have the model and serial numbers of your product ready. Figure 1 identifies the location of the model and serial numbers on the product. Write the numbers in the space provided.

# Contents

Safety .....	4	Engine Safety .....	48
General Safety .....	4	Servicing the Air Cleaner .....	48
Safety and Instructional Decals .....	4	Servicing the Engine Oil.....	49
Setup .....	11	Servicing the Diesel-Oxidation Catalyst (DOC) and the Soot Filter .....	50
1 Installing the PTO Driveshaft to an Optional Mower Deck or QAS.....	11	Fuel System Maintenance .....	51
2 Using the Optional Mower-Deck-Mounting Hardware .....	12	Servicing the Water Separator .....	51
3 Adjusting the Roll Bar.....	12	Servicing the Engine Fuel Filter .....	52
4 Checking the Tire Pressure .....	13	Checking the Fuel Lines and Connections.....	52
5 Checking the Fluid Levels .....	13	Cleaning the Fuel Pick-Up Tube Screen.....	52
Product Overview .....	14	Electrical System Maintenance .....	52
Controls .....	14	Electrical System Safety .....	52
Cab Controls .....	15	Checking the Fuses .....	52
Specifications .....	20	Servicing the Battery.....	53
Attachments/Accessories .....	21	Storing the Battery .....	53
Before Operation .....	21	Drive System Maintenance .....	54
Before Operation Safety .....	21	Checking the Tire Pressure.....	54
Adding Fuel .....	22	Correcting Steering Misalignment.....	54
Checking the Engine-Oil Level.....	23	Cooling System Maintenance .....	55
Checking the Cooling System.....	23	Cooling System Safety .....	55
Checking the Hydraulic System .....	23	Checking the Cooling System .....	55
Think Safety First.....	23	Cleaning the Radiator .....	56
Using the Safety-Interlock System .....	23	Brake Maintenance .....	57
Positioning the Standard Seat .....	24	Adjusting the Service Brakes .....	57
Raising and Lowering the Seat .....	25	Adjusting the Parking Brake.....	57
During Operation .....	26	Belt Maintenance .....	58
During Operation Safety .....	26	Checking the Alternator Belt .....	58
Using the Rollover-Protection System (ROPS)—2-Wheel Drive with ROPS and 4-Wheel Drive with ROPS Models Only .....	27	Controls System Maintenance .....	58
Starting and Shutting Off the Engine .....	28	Adjusting the Traction Drive for Neutral .....	58
Driving the Machine .....	28	Adjusting the Maximum Ground Speed.....	59
Stopping the Machine .....	29	Hydraulic System Maintenance .....	60
Selecting the Steering Mode .....	29	Hydraulic System Safety.....	60
Operating the Mower .....	29	Checking the Hydraulic System .....	60
Adjusting the Height of Cut .....	30	Changing the Hydraulic Fluid And Filter.....	61
Cutting Grass with the Machine .....	30	Cab Maintenance .....	62
Diesel Particulate Filter Regeneration.....	31	Filling the Washer-Fluid Bottle .....	62
Operating Tips .....	39	Cleaning the Cab Air Filters .....	62
After Operation .....	40	Cleaning the Air-Conditioning Coil .....	63
After Operation Safety .....	40	Cleaning .....	64
Pushing the Machine by Hand .....	40	Cleaning the Cab .....	64
Hauling the Machine .....	40	Disposing of Waste .....	64
Locating the Tie-Down Points .....	41	Storage .....	64
Maintenance .....	42	Preparing the Engine .....	64
Recommended Maintenance Schedule(s) .....	42	Preparing the Machine.....	64
Daily Maintenance Checklist.....	43		
Pre-Maintenance Procedures .....	44		
Pre-Maintenance Safety .....	44		
Preparing the Machine for Maintenance.....	45		
Using the Hood-Prop Rod .....	45		
Lubrication .....	46		
Greasing the Bearings and Bushings.....	46		
Engine Maintenance .....	48		

# Safety

This machine has been designed in accordance with EN ISO 5395:2013 and ANSI B71.4-2012.

## General Safety

This product is capable of amputating hands and feet and of throwing objects. Always follow all safety instructions to avoid serious personal injury.

Using this product for purposes other than its intended use could prove dangerous to you and bystanders.

- Read and understand the contents of this *Operator's Manual* before starting the engine.
- Do not put your hands or feet near moving components of the machine.
- Do not operate the machine without all guards and other safety protective devices in place and working on the machine.

- Keep clear of any discharge opening. Keep bystanders and pets a safe distance away from the machine.
- Keep children out of the operating area. Never allow children to operate the machine.
- Stop the machine and shut off the engine before servicing, fueling, or unclogging the machine.

Improperly using or maintaining this machine can result in injury. To reduce the potential for injury, comply with these safety instructions and always pay attention to the safety-alert symbol, which means Caution, Warning, or Danger—personal safety instruction. Failure to comply with these instructions may result in personal injury or death.

You can find additional safety information where needed throughout this *Operator's Manual*.

## Safety and Instructional Decals



Safety decals and instructions are easily visible to the operator and are located near any area of potential danger. Replace any decal that is damaged or missing.

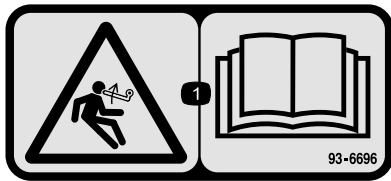

93-6696

decal93-6696

1. Stored energy hazard—read the *Operator's Manual*.



117-3276

decal117-3276

1. Engine coolant under pressure
2. Explosion hazard—read the *Operator's Manual*.
3. Warning—do not touch the hot surface.
4. Warning—read the *Operator's Manual*.

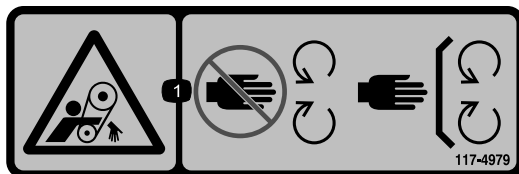

117-4979

decal117-4979

1. Rotating belt—keep guard in place.

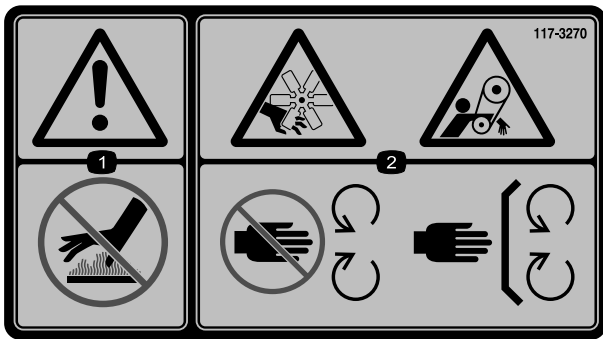

117-3270

decal117-3270

1. Warning—do not touch the hot surface.
2. Cutting/dismemberment hazard, hand; entanglement hazard, belt—stay away from moving parts; keep all guards and shields in place.

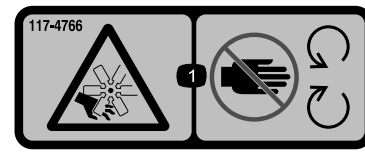

117-4766

decal117-4766

1. Cutting/dismemberment hazard; fan—stay away from moving parts; keep all guards and shields in place.



98-4387

decal98-4387

1. Warning—wear hearing protection.



117-3272

decal117-3272

1. Warning—read the *Operator's Manual*; failure to use the rollover protection system (ROPS) can result in injury in the event of a rollover; wear a seat belt when a roll bar is in place, do not wear a seat belt when the roll bar is lowered.

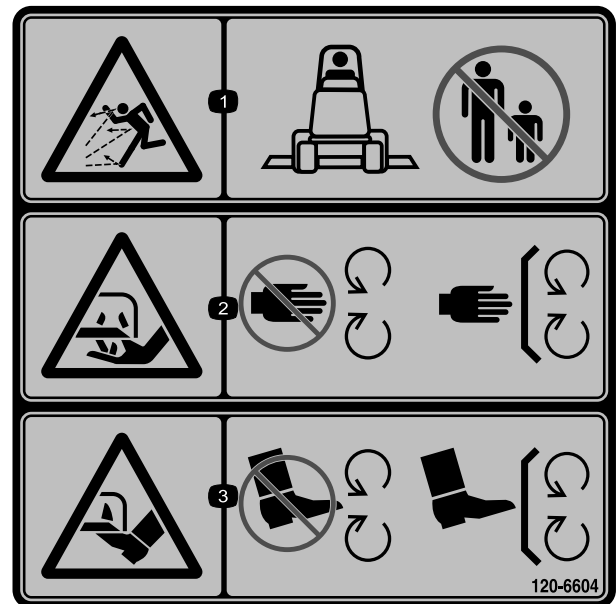

120-6604

decal120-6604

1. Thrown object hazard—keep bystanders away from the machine.
2. Cutting/dismemberment hazard of hand, mower blade—stay away from moving parts; keep all guards and shields in place.
3. Cutting/dismemberment hazard of foot, mower blade—stay away from moving parts; keep all guards and shields in place.

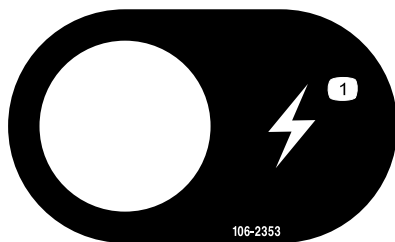

106-2353

decal106-2353

1. Electrical power point

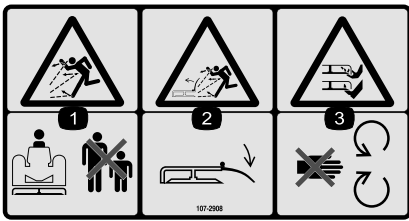

107-2908

decal107-2908

1. Thrown object hazard—keep bystanders a safe distance away from the machine.
2. Thrown object hazard—do not operate the mower with the deflector up or removed; keep the deflector in place.
3. Cutting/dismemberment hazard of hand or foot, mower blade—stay away from moving parts.

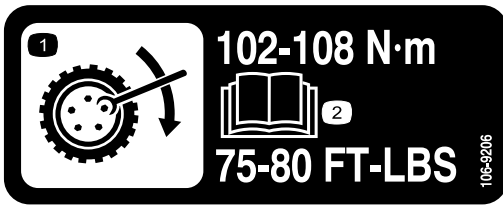

106-9206

decal106-9206

1. Wheel torque specifications
2. Read the *Operator's Manual*.

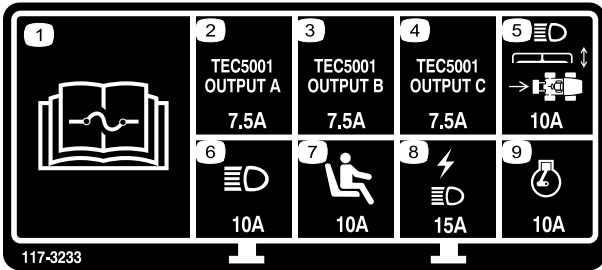

117-3233

decal117-3233

1. Read the *Operator's Manual* for information on fuses.
2. 4-wheel steer solenoid (7.5 A)
3. PTO enable, 4-wheel-steer lamp, deck lift, deck float (7.5 A)
4. Glow indicator, fuel-run solenoid, diagnostic light, start (7.5 A)
5. Headlights, deck actuator, power takeoff (10 A)
6. Lights (15 A)
7. Operator-presence switch (10 A)
8. Power point, lights (15 A)
9. Engine (10 A)

### CALIFORNIA SPARK ARRESTER WARNING

Operation of this equipment may create sparks that can start fires around dry vegetation. A spark arrester may be required. The operator should contact local fire agencies for laws or regulations relating to fire prevention requirements. 117-2718

decal117-2718

117-2718



decalbatterysymbols

### Battery Symbols

Some or all of these symbols are on your battery.

1. Explosion hazard
2. No fire, open flame, or smoking
3. Caustic liquid/chemical burn hazard
4. Wear eye protection.
5. Read the *Operator's Manual*.
6. Keep bystanders a safe distance away from the battery.
7. Wear eye protection; explosive gases can cause blindness and other injuries.
8. Battery acid can cause blindness or severe burns.
9. Flush eyes immediately with water and get medical help fast.
10. Contains lead; do not discard.

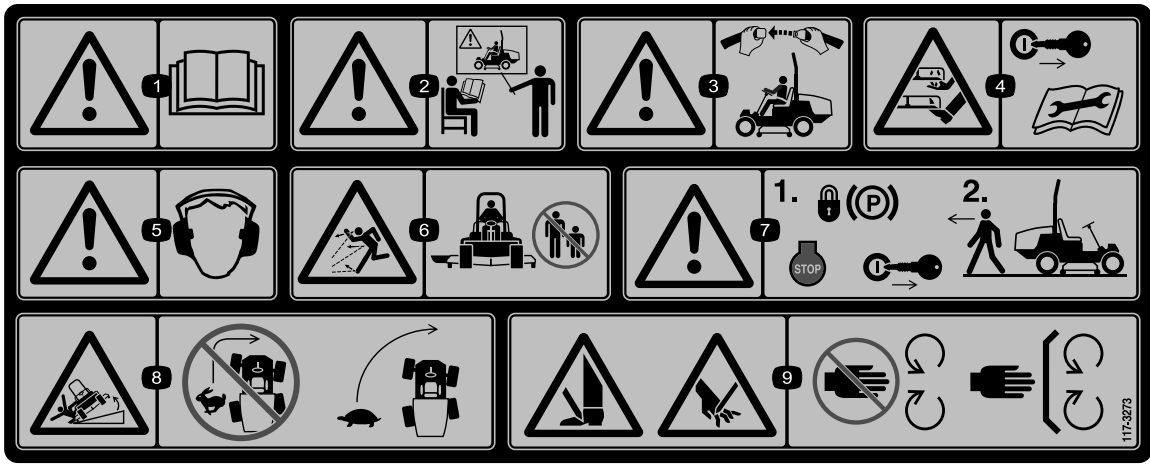

decal117-3273

**117-3273**

- |  |   |
|--|---|
| 1. Warning—read the <i>Operator's Manual</i> .   | 6. Thrown object hazard—keep bystanders a safe distance away from the machine.  |
| 2. Warning—do not operate this machine unless you are trained.   | 7. Warning—engage the parking brake, shut off the engine, and remove the key from the key switch before leaving the machine.    |
| 3. Warning—wear the seat belt when seated in the operator's position.  | 8. Tipping hazard—lower the cutting unit when driving down slopes; slow the machine before turning, do not turn at high speeds. |
| 4. Cutting/dismemberment hazard of hand or foot—remove the key from the key switch and read the instructions before servicing or performing maintenance. | 9. Cutting hazard of hand or foot—stay away from moving parts; keep all guards in place.  |
| 5. Warning—wear hearing protection.  |   |

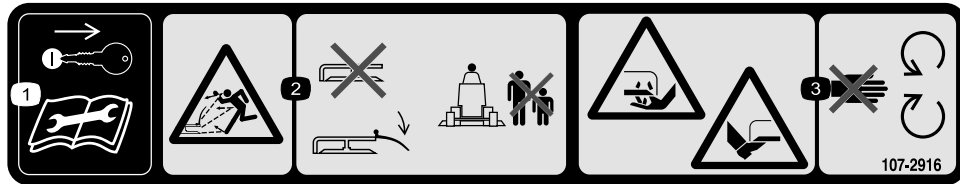

decal107-2916

**107-2916**

- |   |  |   |
|---|--|---|
| 1. Remove the key from the key switch and read the <i>Operator's Manual</i> before servicing or performing maintenance. | 2. Thrown object hazard—do not operate the mower with the deflector up or removed; keep the deflector in place; keep bystanders a safe distance away from the machine. | 3. Cutting/dismemberment hazard of hand or foot, mower blade—stay away from moving parts. |
|---|--|---|

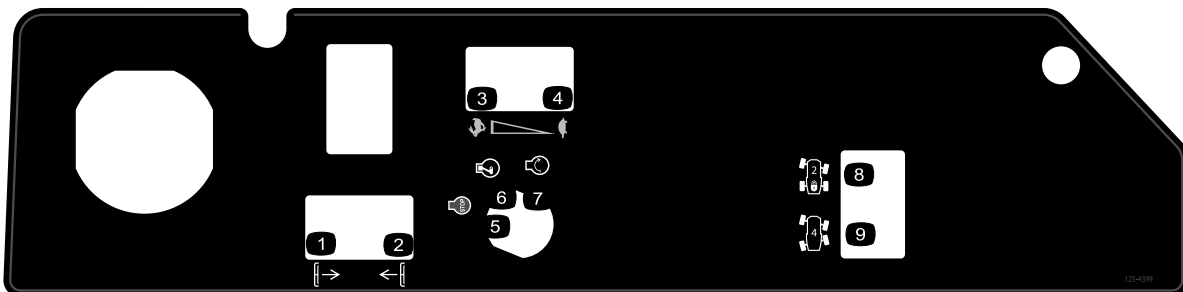

decal125-4399

**125-4399**

- |                   |                    |                     |
|-------------------|--------------------|---------------------|
| 1. Lower the deck | 4. Slow            | 7. Engine—start     |
| 2. Raise the deck | 5. Engine—shut off | 8. 2-wheel steering |
| 3. Fast           | 6. Engine—run      | 9. 4-wheel steering |

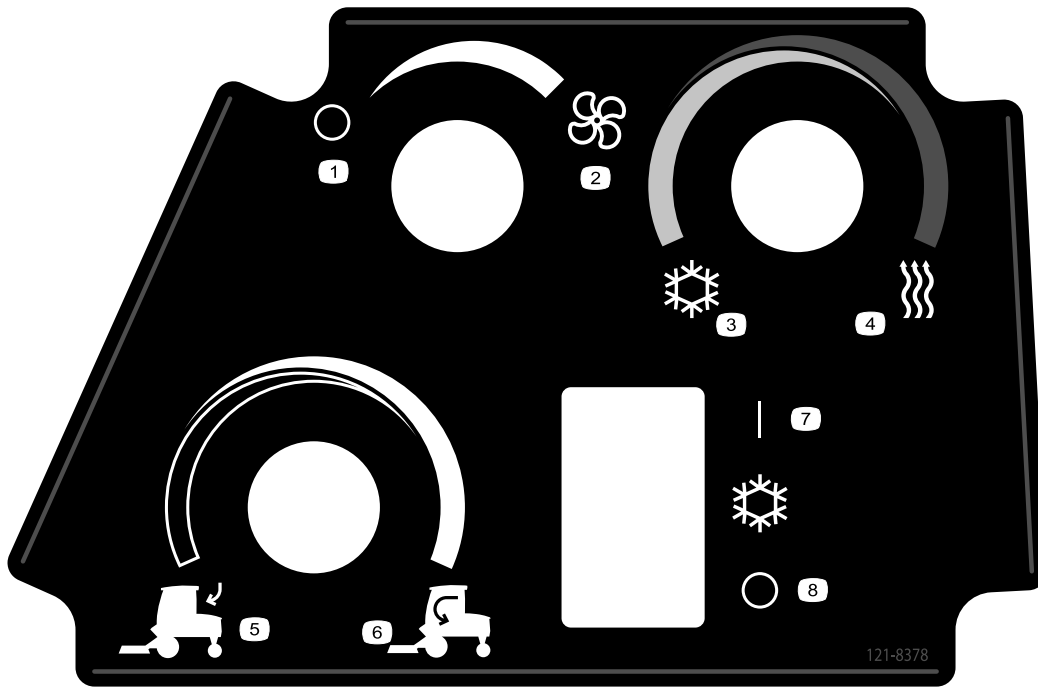

121-8378

decal121-8378

**121-8378**

Model with Cab Only

- |                |                        |
|----------------|------------------------|
| 1. Fan—off     | 5. External air        |
| 2. Fan—on full | 6. Internal air        |
| 3. Cold air    | 7. Air conditioner—off |
| 4. Hot air     | 8. Air conditioner—on  |

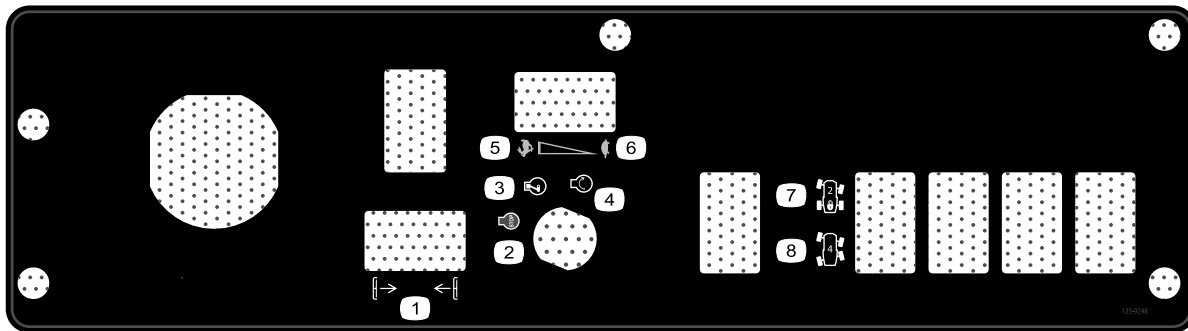

125-9248

decal125-9248

**125-9248**

Model with Cab Only

- |                      |                     |
|----------------------|---------------------|
| 1. Raise/Lower decks | 5. Fast             |
| 2. Engine—stop       | 6. Slow             |
| 3. Engine—run        | 7. 2-wheel steering |
| 4. Engine—start      | 8. 4-wheel steering |



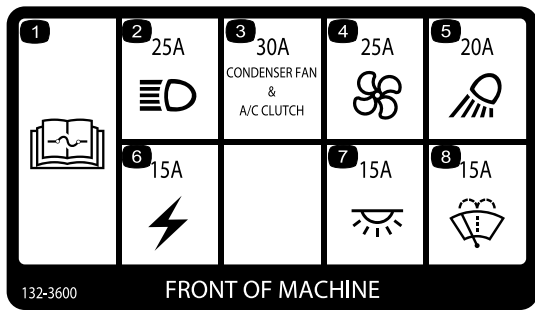

132-3600

FRONT OF MACHINE

decal132-3600

**132-3600**

Model with Cab Only

- |   |                             |
|---|-----------------------------|
| 1. Read the <i>Operator's Manual</i> for more information on fuses. | 5. Working light (20 A)     |
| 2. Headlight (25 A)   | 6. Auxiliary power (15 A)   |
| 3. Condenser fan and A/C clutch (30 A)                              | 7. Cab light (15 A)         |
| 4. Fan (25 A)   | 8. Windshield wipers (15 A) |

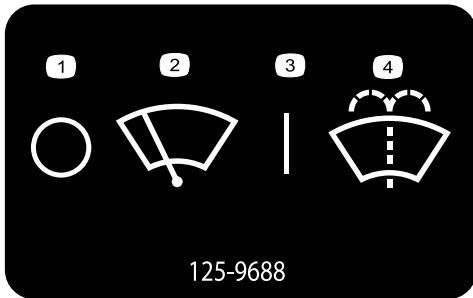

125-9688

decal125-9688

**125-9688**

Model with Cab Only

- |                          |                                  |
|--------------------------|----------------------------------|
| 1. Windshield wipers—off | 3. Windshield wipers—on          |
| 2. Windshield wipers     | 4. Spray windshield washer fluid |

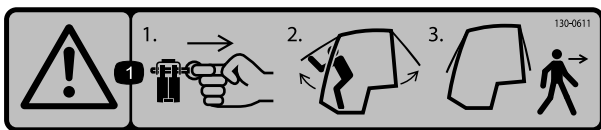

decal130-0611

**130-0611**

Model with Cab Only

1. Warning—1) Remove the pin; 2) Raise the doors; 3) Exit the cab

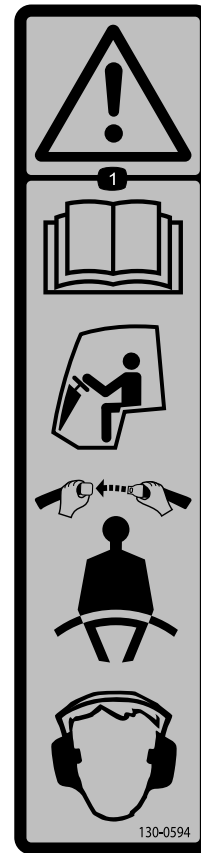

130-0594

decal130-0594

**130-0594**

Model with Cab Only

1. Warning—read the *Operator's Manual*; when sitting in the cab, always wear a seat belt; wear hearing protection.

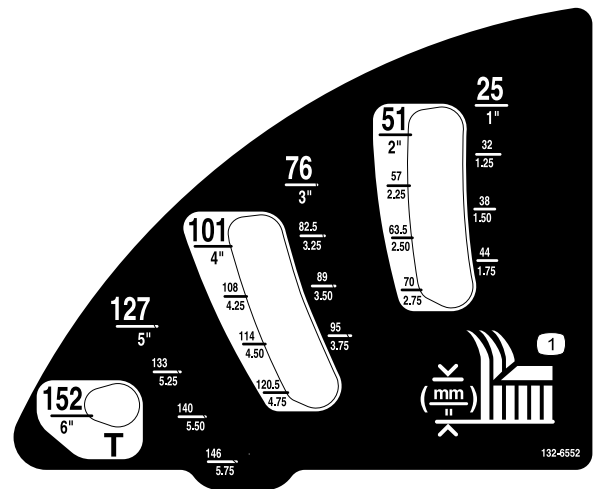

132-6552

decal132-6552

**132-6552**

2-Wheel Drive with ROPS and 4-Wheel Drive with ROPS Models Only

1. Height of cut

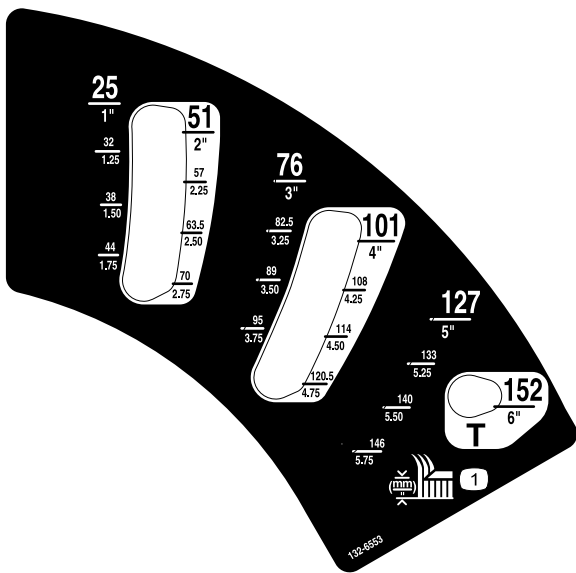

132-6553

Model with Cab Only

decal132-6553

1. Height of cut

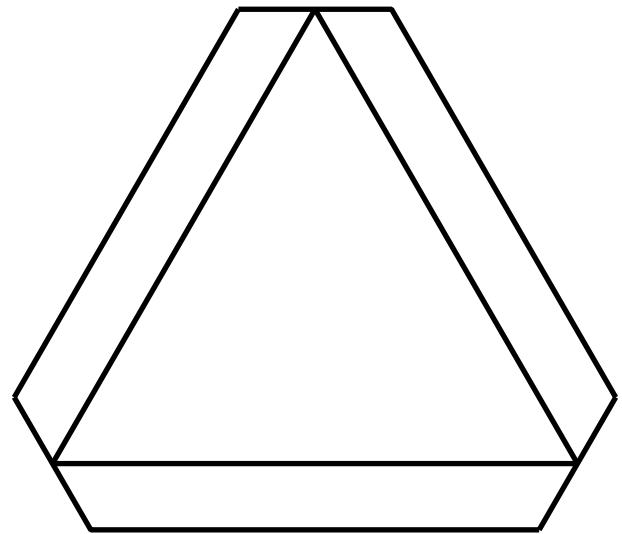

120-0250

decal120-0250

1. Slow-moving vehicle

# GROUNDMASTER 360

## QUICK REFERENCE AID

CHECK/SERVICE (daily)

1. OIL LEVEL, ENGINE
2. OIL LEVEL, HYDRAULIC TANK
3. COOLANT LEVEL, RADIATOR
4. FUEL /WATER SEPARATOR
5. PRECLEANER - AIR CLEANER

6. RADIATOR SCREEN
  7. BRAKE FUNCTION
  8. TIRE PRESSURE
  9. BATTERY
  10. BELTS - DECK, FAN, ALTERNATOR
  11. GEARBOX
- GREASING - SEE OPERATOR'S MANUAL

### FLUID SPECIFICATIONS/CHANGE INTERVALS

SEE OPERATOR'S MANUAL FOR INITIAL CHANGES.	FLUID TYPE	CAPACITY	CHANGE INTERVAL*		FILTER PART NO.
			FLUID	FILTER	
A. ENGINE OIL	15W-40 CJ-4	5.5 QTS.	250 HRS.	250 HRS.	125-7025
B. HYDRAULIC CIRCUIT OIL	MOBIL 424	4.5 GALS. (7.7 LITERS)	800 HRS.	800 HRS.	108-5194
C. AIR CLEANER				SEE INDICATOR	108-3810
D. WATER SEPARATOR				400 HRS.	125-2915
E. FUEL TANK	NO. 2-DIESEL	13.5 GALS. (51.1 LITERS)	DRAIN AND FLUSH, 2 YRS.		
F. COOLANT	50/50 ETHYLENE GLYCOL/WATER	8 QTS. (7.5 LITERS)	DRAIN AND FLUSH, 2 YRS.		
G. GEARBOX	80W-90 GEAR OIL SYNTH: Mobilube SHC 75W-90	14 fl oz. (414 mL)	400 HRS.		

\*SEE OPERATOR'S MANUAL FOR INITIAL CHANGES / WINTER USE.

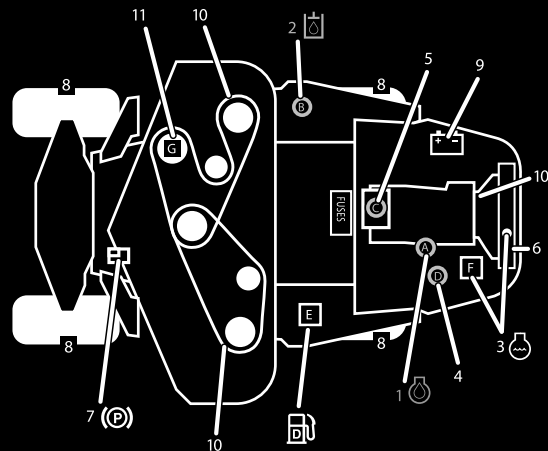

131-1946

131-1946

decal131-1946

1. Read the *Operator's Manual* for more information on servicing the machine.

# Setup

## Loose Parts

Use the chart below to verify that all parts have been shipped.

Procedure	Description	Qty.	Use
<b>1</b>	PTO driveshaft	1	Install the PTO driveshaft to a optional deck or QAS.
	Bolt (5/16 x 1-3/4 inches)	4	
	Locknut (5/16 inch)	4	
	Roll pin (3/16 x 1-1/2 inches)	2	
<b>2</b>	Retainer pin	2	Use the hardware to install the optional mower deck.
	Grease fitting	2	
	Washer head screw (5/16 x 7/8 inch)	2	
<b>3</b>	No parts required	–	Adjust the roll bar.
<b>4</b>	No parts required	–	Check the tire pressure.
<b>5</b>	No parts required	–	Check the levels of the hydraulic fluid, engine oil, and coolant.

## Media and Additional Parts

Description	Qty.	Use
Operator's Manual	1	Read the manual before operating the machine.
Engine owner's manual	1	Read the manual before operating the machine.
Parts Catalog	1	Use the Parts Catalog to reference part numbers.
Operator training material	1	Review before operating machine

# 1

## Installing the PTO Driveshaft to an Optional Mower Deck or QAS

Parts needed for this procedure:

1	PTO driveshaft
4	Bolt (5/16 x 1-3/4 inches)
4	Locknut (5/16 inch)
2	Roll pin (3/16 x 1-1/2 inches)

## Procedure

**Note:** Installing the PTO driveshaft is easier if you position the machine on a hoist.

1. Park the machine on a level surface, engage the parking brake, shut off the engine, and remove the key from the key switch.

### **⚠ WARNING**

**Do not start the engine and engage the PTO switch when the PTO driveshaft is disconnected from the cutting deck. If you start the engine and the PTO shaft is allowed to rotate, serious personal injury and machine damage could result. Before the PTO driveshaft is disconnected from the cutting deck, disconnect the PTO solenoid-valve-coil connector from the wire harness to prevent unintentionally engaging the PTO clutch.**

2. Disconnect the wire-harness connector from the PTO solenoid-valve-coil connector ([Figure 3](#)).

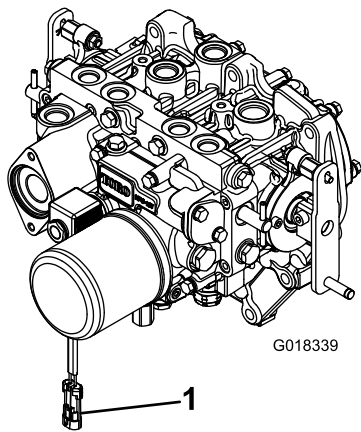

Figure 3

1. Wire-harness connector

3. Position the PTO driveshaft under the front of the machine. Ensure that the slip-shaft yoke of the driveshaft is positioned toward the transmission driveshaft (Figure 4).

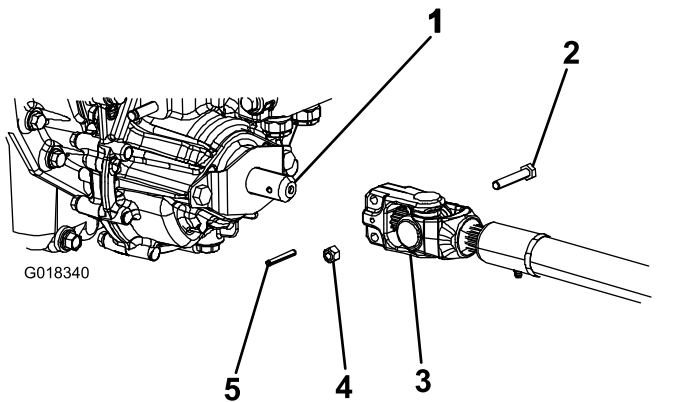

Figure 4

1. Transmission driveshaft
2. Bolt
3. PTO driveshaft
4. Locknut
5. Roll pin

4. Align the spline and roll-pin hole of the driveshaft yoke with the transmission driveshaft.
5. Slide the PTO driveshaft end yoke onto the transmission driveshaft.
6. Secure the end yoke of the PTO driveshaft as follows:
  - A. Install the roll pin in the end yoke and shaft.
  - B. Install the bolts through the driveshaft end yoke.
  - C. Install and tighten the locknuts to secure the end yoke to the PTO driveshaft.

**Note:** Retain the remaining bolts, locknuts, and roll pin to secure the other end of the driveshaft to the attachment gearbox shaft.

D. Torque the locknuts to 20 to 25 N-m (175 to 225 in-lb).

7. Lubricate the grease fittings on the PTO driveshaft.
8. After you connect the other end of the driveshaft to the attachment gearbox shaft, connect the wire-harness connector to the PTO solenoid-valve-coil connector (Figure 3).

## 2

### Using the Optional Mower-Deck-Mounting Hardware

Parts needed for this procedure:

2	Retainer pin
2	Grease fitting
2	Washer head screw (5/16 x 7/8 inch)

### Procedure

**Note:** These components and procedure are required only if a mower deck that requires retainer pins is mounted to the traction unit. Refer to the mower deck *Operator's Manual* for the installation instructions.

**Note:** If you are not installing a mower deck on the traction unit, remove or tie up the 4 deck-lift chains from the lift suspension.

## 3

### Adjusting the Roll Bar

No Parts Required

### Procedure

1. Remove the hairpin cotters and the pins from the roll bar (Figure 5).
2. Raise the roll bar to the upright position and install the 2 pins and secure them with the hairpin cotters (Figure 5).

**Note:** If you must lower the roll bar, push the bar forward to relieve pressure on the pins, remove the pins, lower the bar slowly, and secure it with the pins so that it does not damage the hood.

Do not wear the seat belt when the roll bar is folded down.

3. Check the cooling system before starting the engine; refer to [Checking the Cooling System \(page 55\)](#).

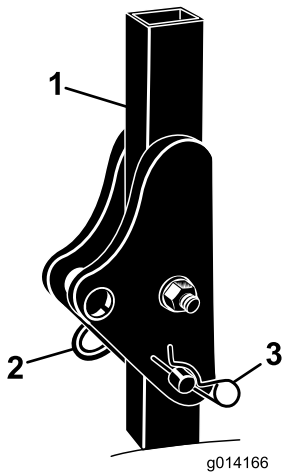

**Figure 5**

g014166

1. Roll bar
2. Pin
3. Hairpin cotter

# 4

## Checking the Tire Pressure

No Parts Required

### Procedure

The tires are overinflated for shipping. Therefore, release some of the air to reduce the pressure. Check the tire pressure; refer to [Checking the Tire Pressure \(page 54\)](#).

# 5

## Checking the Fluid Levels

No Parts Required

### Procedure

1. Check the level of the hydraulic fluid before starting the engine; refer to [Checking the Hydraulic System \(page 60\)](#).
2. Check the level of the engine oil before starting the engine; refer to [Checking the Engine-Oil Level \(page 49\)](#).

# Product Overview

## Controls

Become familiar with all the controls before you start the engine and operate the machine.

### Traction Pedal

The traction pedal (Figure 6) controls the forward and reverse operation. Press the top of the pedal to move forward and the bottom to move rearward. The ground speed depends on how far you press the pedal. For no load, maximum ground speed, fully press the pedal while the throttle is in the FAST position.

To stop the machine, reduce the foot pressure on the traction pedal and allow it to return to the center position.

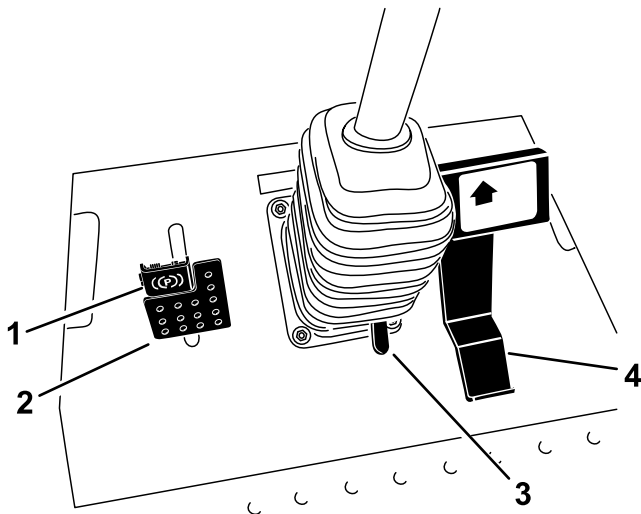

Figure 6

- |                  |                        |
|------------------|------------------------|
| 1. Parking brake | 3. Tilt-steering pedal |
| 2. Brake pedal   | 4. Traction pedal      |

### Brake Pedal

Use the brake pedal with the brake-pedal latch to engage and disengage the parking brake (Figure 6). To stop the machine, release the traction pedal and allow it to return to the center position. You can use the brake to assist in stopping the machine in an emergency situation.

### Parking Brake

To engage the parking brake, push down on the brake pedal and press the top forward to latch it (Figure 6). To disengage the parking brake, press the brake pedal until the parking-brake latch retracts.

### Tilt-Steering Pedal

To tilt the steering wheel toward you, press the foot pedal down and pull the steering tower toward you to the most comfortable position and then release the pedal (Figure 6).

### Engine-Speed Switch

The engine-speed switch (Figure 7) has 2 modes to change the engine speed. By momentarily tapping the switch, you can increase or decrease the engine speed in increments of 100 rpm. Press and hold the switch to set the engine speed directly to high or low idle, depending on which end of the switch you press.

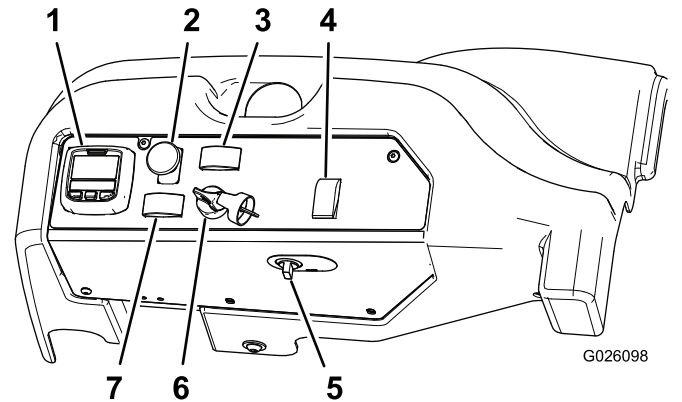

Figure 7

- |                               |                     |
|-------------------------------|---------------------|
| 1. InfoCenter                 | 5. Power point      |
| 2. Power-takeoff (PTO) switch | 6. Key switch       |
| 3. Engine-speed switch        | 7. Deck-lift switch |
| 4. Steering selector switch   |                     |

### InfoCenter

The InfoCenter LCD display shows the operating status, various diagnostics, and other information about the machine (Figure 7).

### Key Switch

The key switch has 3 positions: OFF, ON/PREHEAT, and START (Figure 7).

### Power-Takeoff (PTO) Switch

The power-takeoff (PTO) switch starts and stops the attachment (Figure 7).

### Steering Selector Switch

#### 4-Wheel Drive Machines Only

Press the steering selector switch to the rear to engage 4-wheel steering and forward to return to 2-wheel steering (Figure 7).

## Power Point

The power point provides a 12 V power supply for electronic devices (Figure 7).

**Important:** If the mower deck shuts down and the InfoCenter temperature-warning icon is on, push the PTO knob down; drive to a safe, flat area; move the throttle lever to the SLOW position; allow the traction pedal to move to the NEUTRAL position; and engage the parking brake. Allow the engine to idle for several minutes while it cools to a safe level. Shut off the engine and check the cooling system; refer to [Checking the Cooling System](#) (page 55).

## Fuel Gauge

The fuel gauge (Figure 8) indicates the fuel level remaining in the fuel tank.

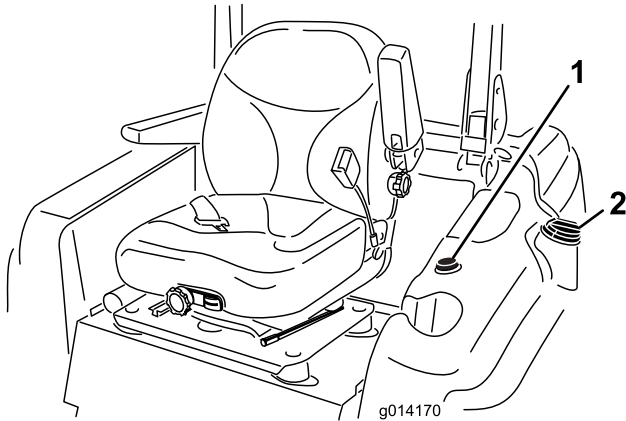

Figure 8

1. Fuel gauge
2. Fuel-tank cap

## Cab Controls

### Model with Cab Only

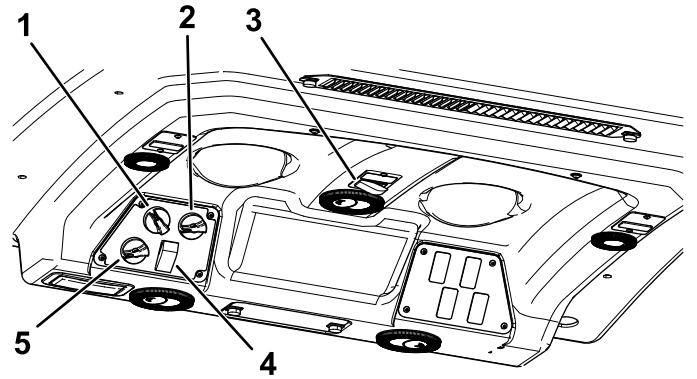

Figure 9

1. Fan control
2. Temperature control
3. Windshield-wiper switch
4. Air-conditioning switch
5. Air-recirculation control

### Air-Recirculation Control

Sets the cab to either recirculate the air in the cabin or to draw air into the cabin from outside (Figure 9).

- Set it to recirculate the air when using the air-conditioning.
- Set it to draw air in when using the heater or fan.

### Fan-Control Knob

Rotate the fan-control knob to regulate the speed of the fan (Figure 9).

### Temperature-Control-Knob

Rotate the temperature-control knob to regulate the air temperature in the cab (Figure 9).

### Windshield-Wiper Switch

Use this switch to turn the wind shield wipers on or off (Figure 9).

### Air-Conditioning Switch

Use this switch to turn the air conditioning on or off (Figure 9).

### Windshield Latch

Lift up the latch to open the windshield (Figure 10). Press in the latch to lock the windshield in the open position. Pull out and down on the latch to close and secure the windshield.

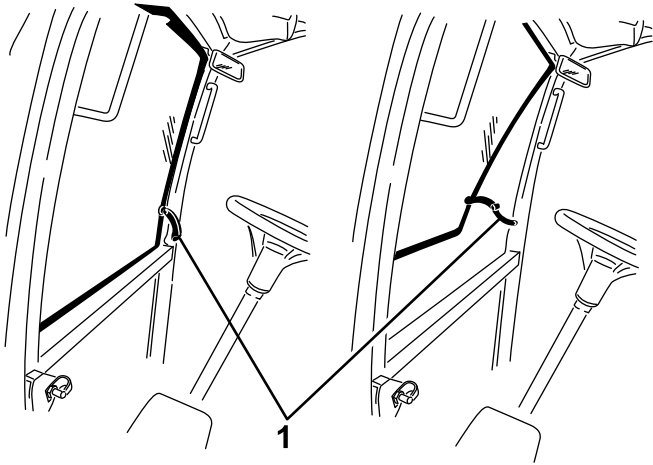

**Figure 10**

g196911

1. Windshield latch

### Rear Window Latch

Lift up the latches to open the rear window. Press in the latch to lock the window in the open position. Pull out and down on the latch to close and secure the window (Figure 10).

**Important:** You must close the rear window before opening the hood; otherwise, damage may occur.

## Using the InfoCenter LCD Display

The InfoCenter LCD display shows information about your machine, such as the operating status, various diagnostics, and other information about the machine (Figure 11). There is a splash screen and main information screen of the InfoCenter. You can switch between the splash screen and main information screen at any time by pressing any of the InfoCenter buttons and then selecting the appropriate directional arrow.

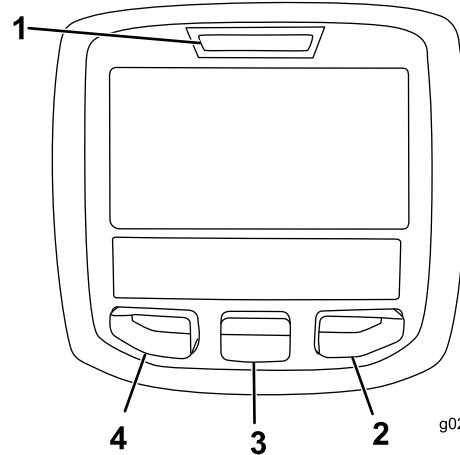

g020650

g020650

**Figure 11**





















- |                    |                  |
|--------------------|------------------|
| 1. Indicator light | 3. Middle button |
| 2. Right button    | 4. Left button   |

- Left button, menu access/back button—press this button to access the InfoCenter menus. You can use it to back out of any menu that you are currently using.
- Middle button—use this button to scroll down menus.
- Right button—use this button to open a menu where a right arrow indicates additional content.











**Note:** The purpose of each button may change depending on what is required at the time. Each button is labeled with an icon displaying its current function.



## InfoCenter Icon Description

<b>SERVICE DUE</b>	Indicates when scheduled service should be performed
	Engine rpm/status—indicates the engine rpm
	Hour meter
	Info icon
	Fast
	Slow
	Stationary regeneration required
	Glow plugs are active
	AC
	2-wheel steer
	4-wheel steer
	Operator must sit in seat
	Parking brake indicator—indicates when the parking brake is set
	Coolant Temperature—indicates the engine coolant temperature in either °C or °F
	Temperature (hot)
	PTO is engaged
	Denied or not allowed
	Engine start
	Stop or shutdown
	Engine
	Key switch
<b>PIN</b>	PIN code
<b>CAN</b>	CAN bus

## InfoCenter Icon Description (cont'd.)

	InfoCenter
<b>Bad</b>	Bad or failed
	Bulb
<b>OUT</b>	Output of TEC controller or control wire in harness
	Switch
	Operator must release switch
	Operator should change to indicated state
Symbols are often combined to form sentences. Some examples are shown below	
	Operator should put machine in Neutral
	Engine start denied
	Engine shutdown
	Engine coolant too hot
	DPF ash accumulation notification. Refer to <a href="#">Servicing the Diesel-Oxidation Catalyst (DOC) and the Soot Filter (page 50)</a> for details.
	Sit down or engage parking brake

## Using the Menus

To access the InfoCenter menu system, press the menu access button while at the main screen. This brings you to the main menu. Refer to the following tables for a synopsis of the options available from the menus:

Main Menu	
Menu Item	Description

Faults	The Faults menu contains a list of the recent machine faults. Refer to the Service Manual or your Authorized Toro Distributor for more information on the Faults menu and the information contained there.
Service	The Service menu contains information on the machine such as hours of use counters and other similar numbers.
Diagnostics	The Diagnostics menu displays the state of each machine switch, sensor and control output. You can use this to troubleshoot certain issues as it will quickly tell you which machine controls are on and which are off.
Settings	The Settings menu allows you to customize and modify configuration variables on the InfoCenter display.
About	The About menu lists the model number, serial number, and software version of your machine.

Service	
Menu Item	Description
Hours	Lists the total number of hours that the machine, engine, and PTO have been on, as well as the number of hours the machine has been transported and service due
Counts	Lists numerous counts the machine has experienced

Diagnostics	
Menu Item	Description
PTO	Indicates the inputs, qualifiers, and outputs for enabling the PTO circuit
Engine Run	Indicates the inputs, qualifiers, and outputs for starting the engine
Decks	Indicates the inputs, qualifiers, and outputs for lifting and lowering the deck
Steer Mode	Indicates the inputs, qualifiers, and outputs for switching between 2-wheel steer and 4-wheel steer
Machine Input	Indicates the state of other machine inputs such as accessories and A/C clutch

Settings	
Menu Item	Description
Units	Controls the units used on the InfoCenter; The menu choices are English or Metric.
Language	Controls the language used on the InfoCenter*
LCD Backlight	Controls the brightness of the LCD display
LCD Contrast	Controls the contrast of the LCD display
Protected Menu	Allows a person authorized by your company with the PIN code to access protected menus.
Auto Idle	Controls the amount of time allowed before returning the engine to low idle when the machine is stationary

Only operator-faced text is translated. Faults, Service, and Diagnostics screens are service-faced. The titles are in the selected language, but the menu items are in English.

About	
Menu Item	Description
Model	Lists the model number of the machine
SN	Lists the serial number of the machine
Machine Controller Revision	Lists the software revision of the master controller
InfoCenter Revision	Lists the software revision of the InfoCenter
CAN Bus	Lists the machine communication bus status

## Protected Menu

There are 2 operating configuration settings that are adjustable within the Settings Menu of the InfoCenter: Auto Idle time delay and Stationary Regeneration; refer to [Diesel Particulate Filter Regeneration \(page 31\)](#). You can lock these settings by using the Protected Menu.

**Note:** At the time of delivery, the initial password code is programmed by your distributor.

## Accessing Protected Menus

**Note:** The factory default PIN code for you machine is either 0000 or 1234.

If you changed the PIN code and forgot the code, contact your Authorized Toro Distributor for assistance.

1. From the MAIN MENU, use the center button to scroll down to the SETTINGS MENU and press the right button (Figure 12).

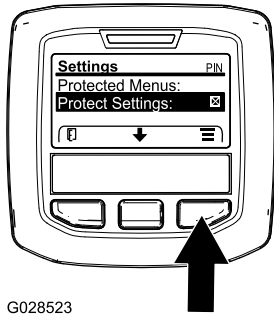

G028523

g028523

Figure 12

2. In the SETTINGS MENU, use the center button to scroll down to the PROTECTED MENU and press the right button (Figure 13A).

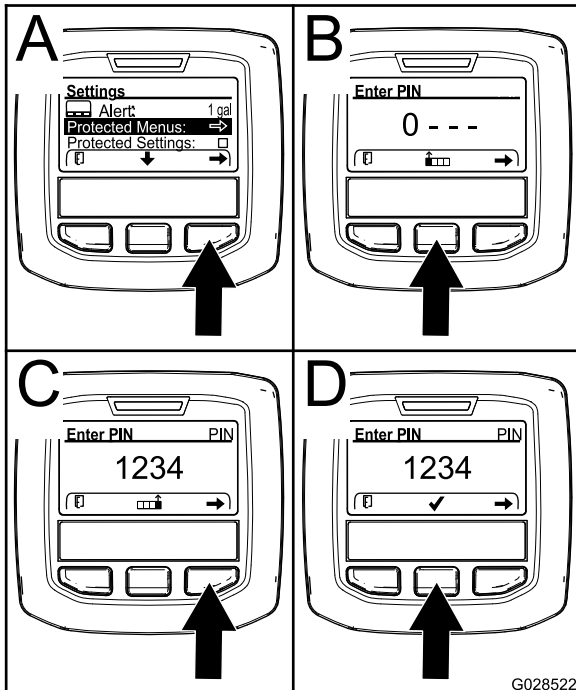

G028522

g028522

Figure 13

3. To enter the PIN code, press the center button until the correct first digit appears, then press the right button to move on to the next digit (Figure 13B and Figure 13C). Repeat this step until the last digit is entered and press the right button once more.
4. Press the middle button to enter the PIN code (Figure 13D).

Wait until the red indicator light of the InfoCenter illuminates.

**Note:** If the InfoCenter accepts the PIN code and the protected menu is unlocked, the word

“PIN” displays in the upper right corner of the screen.

**Note:** Rotate the key switch to the OFF position and then to the ON position locks the protected menu.

You have the ability to view and change the settings in the Protected Menu. Once you access the Protected Menu, scroll down to Protect Settings option. Use the right button to change the setting. Setting the Protect Settings to OFF allows you to view and change the settings in the Protected Menu without entering the PIN code. Setting the Protect Settings to ON hides the protected options and requires you to enter the PIN code to change the setting in the Protected Menu. After you set the PIN code, rotate the key switch OFF and back to the ON position to enable and save this feature.

## Setting the Auto Idle

- In the Settings Menu, scroll down to Auto Idle.
- Press the right button to change the Auto Idle time between OFF, 8S, 10S, 15S, 20S, and 30S.

# Specifications

**Note:** Specifications and design are subject to change without notice.

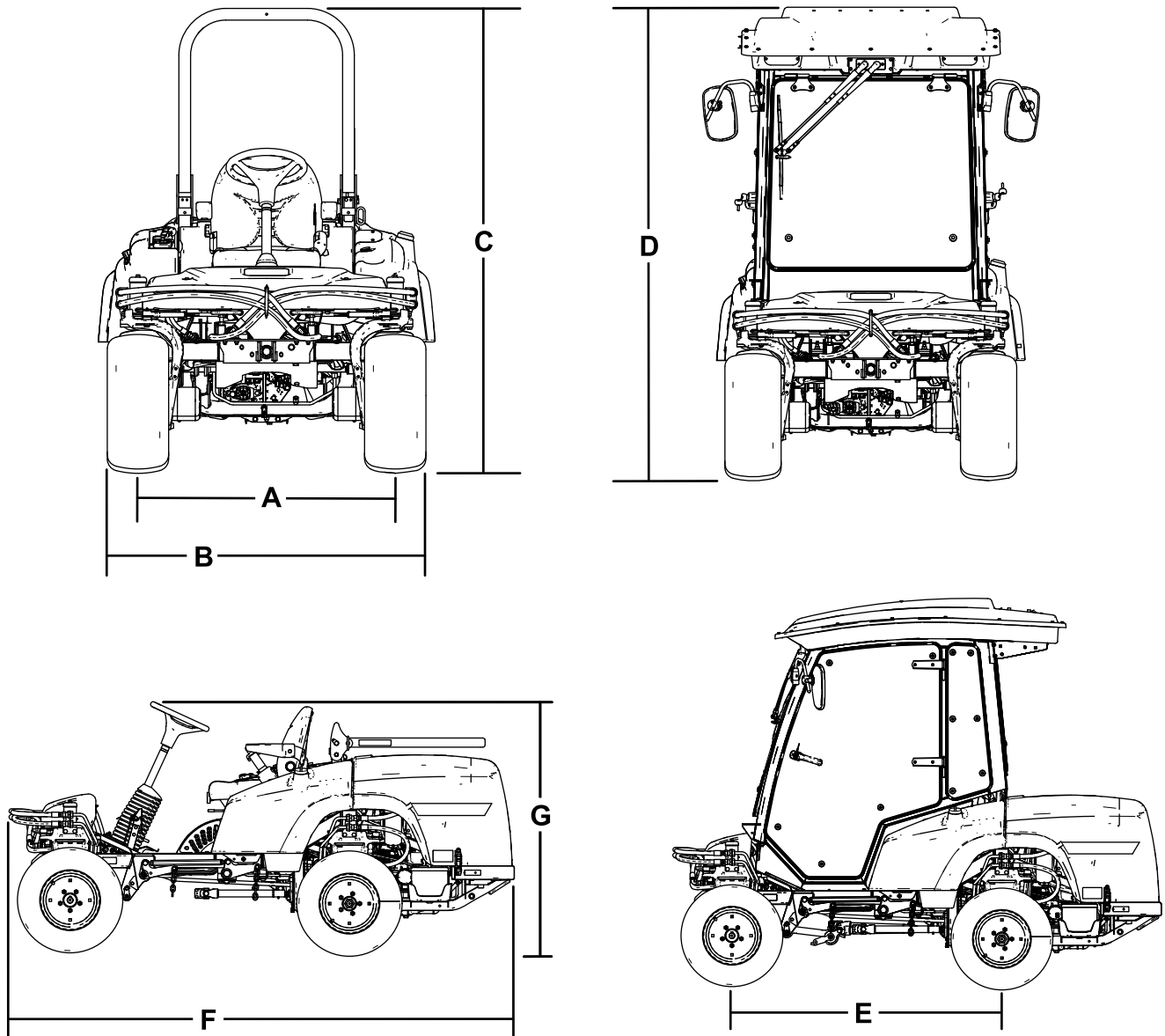

**Figure 14**

g198083

Description	Figure 14 Reference	Dimension or Weight
Height with roll bar up	C	202 cm (80 inches)
Height with roll bar down	G	140 cm (55 inches)
Height with cab	D	225 cm (88-1/2 inches)
Overall length	F	276 cm (108-1/2 inches)
Overall width	B	138 cm (54 inches)
Wheel base	E	155 cm (61 inches)
Wheel tread (tire center to center) rear	A	112 cm (44 inches)
Ground clearance		15 cm (6 inches)

## Weight of the Machine with Mower Decks

	4-Wheel Drive Machine with ROPS	Machine with Cab	2-Wheel Drive Machine with ROPS
No mower deck	1,152 kg (2,540 lb)	1,435 kg (3,163 lb)	1,130 kg (2,492 lb)
72 inch side discharge mower deck	1,363 kg (3,004 lb)	1,645 kg (3,627 lb)	1,341 kg (2,956 lb)
72 inch base mower deck	1,341 kg (2,956 lb)	1,623 kg (3,579 lb)	1,319 kg (2,908 lb)
62 inch base mower deck	1,324 kg (2,918 lb)	1,606 kg (3,541 lb)	1,302 kg (2,870 lb)
100 inch rear discharge mower deck	1,510 kg (3,330 lb)	1,793 kg (3,953 lb)	1,489 kg (3,282 lb)

## Attachments/Accessories

A selection of Toro approved attachments and accessories is available for use with the machine to enhance and expand its capabilities. Contact your Authorized Service Dealer or Distributor or go to [www.Toro.com](http://www.Toro.com) for a list of all approved attachments and accessories.

# Operation

**Note:** Determine the left and right sides of the machine from the normal operating position.

## Before Operation

### Before Operation Safety

#### General Safety

- Never allow children or untrained people to operate or service the machine. Local regulations may restrict the age of the operator. The owner is responsible for training all operators and mechanics.
- Become familiar with the safe operation of the equipment, operator controls, and safety signs.
- Know how to stop the machine and engine quickly.
- Check that operator-presence controls, safety switches, and shields are attached and functioning properly. Do not operate the machine unless they are functioning properly.
- Before mowing, always inspect the machine to ensure that the blades, blade bolts, and cutting assemblies are in good working condition. Replace worn or damaged blades and bolts in sets to preserve balance.
- Inspect the area where you will use the machine and remove all objects that the machine could throw.

#### Fuel Safety

- Use extreme care in handling fuel. It is flammable and its vapors are explosive.
- Extinguish all cigarettes, cigars, pipes, and other sources of ignition.
- Use only an approved fuel container.
- Never remove the fuel cap or fill the fuel tank while the engine is running or hot.
- Never refuel the machine in an enclosed space.
- Never store the machine or fuel container where there is an open flame, spark, or pilot light, such as on a water heater or other appliance.
- If you spill fuel, do not attempt to start the engine; avoid creating any source of ignition until the fuel vapors have dissipated.

# Adding Fuel

## Fuel Specification

**Important:** Use only ultra-low sulphur diesel fuel. Fuel with higher rates of sulfur degrades the diesel oxidation catalyst (DOC), which causes operational problems and shortens the service life of engine components.

**Failure to observe the following cautions may damage the engine.**

- Never use kerosene or gasoline instead of diesel fuel.
- Never mix kerosene or used engine oil with the diesel fuel.
- Never keep fuel in containers with zinc plating on the inside.
- Do not use fuel additives.

## Petroleum Diesel

**Cetane rating:** 45 or higher

**Sulfur content:** Ultra-low sulfur (<15 ppm)

## Fuel Table

Diesel fuel specification	Location
ASTM D975 No. 1-D S15 No. 2-D S15	USA
EN 590	European Union
ISO 8217 DMX	International
JIS K2204 Grade No. 2	Japan
KSM-2610	Korea

- Use only clean, fresh diesel fuel or biodiesel fuels.
- Purchase fuel in quantities that can be used within 180 days to ensure fuel freshness.

Use summer-grade diesel fuel (No. 2-D) at temperatures above -7°C (20°F) and winter-grade fuel (No. 1-D or No. 1-D/2-D blend) below that temperature.

**Note:** Use of winter-grade fuel at lower temperatures provides lower flash point and cold flow characteristics which eases starting and reduces fuel filter plugging. Using summer-grade fuel above -7°C (20°F) contributes toward longer fuel pump life and increased power compared to winter-grade fuel.

## Biodiesel

This machine can also use a biodiesel blended fuel of up to B20 (20% biodiesel, 80% petroleum diesel).

**Sulfur content:** Ultra-low sulfur (<15 ppm)

**Biodiesel fuel specification:** ASTM D6751 or EN14214

**Blended fuel specification:** ASTM D975, EN590, or JIS K2204

**Important:** The petroleum diesel portion must be ultra-low sulfur.

Observe the following precautions:

- Biodiesel blends may damage painted surfaces.
- Use B5 (biodiesel content of 5%) or lesser blends in cold weather.
- Monitor seals, hoses, gaskets in contact with fuel as they may be degraded over time.
- Fuel filter plugging may be expected for a time after converting to biodiesel blends.
- Contact your Authorized Toro Distributor if you wish for more information on biodiesel.

## Fuel Tank Capacity

51 L (13.5 US gallons)

## Filling the Fuel Tank

**Note:** If possible, fill the fuel tank after each use. This minimizes possible buildup of condensation inside the fuel tank.

1. Park the machine on a level surface.
2. Shut off the engine and engage the parking brake.
3. Clean around the fuel-tank cap and remove the cap (Figure 15).

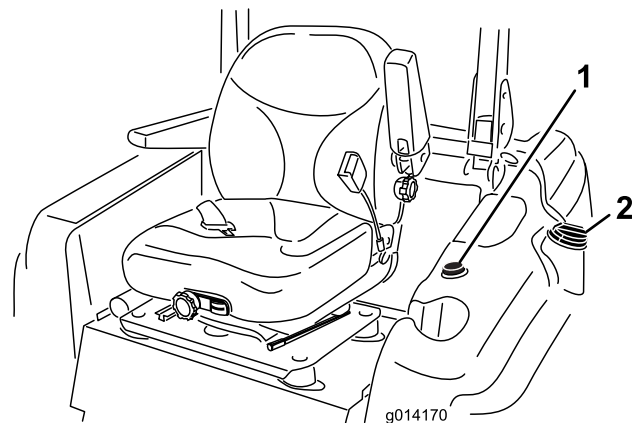

**Figure 15**

1. Fuel gauge
2. Fuel-tank cap

**Important:** Do not open the fuel tank when parked on a hill. The fuel could spill out.

4. Add fuel to the fuel tank until the level is even with the bottom of the filler neck. **Do not overfill the fuel tank.**
5. Install the fuel-tank cap and secure. Wipe up any spilled fuel.

## Checking the Engine-Oil Level

Before you start the engine and use the machine, check the oil level in the engine crankcase; refer to [Checking the Engine-Oil Level \(page 49\)](#).

## Checking the Cooling System

Before you start the engine and use the machine, check the cooling system; refer to [Checking the Cooling System \(page 55\)](#).

## Checking the Hydraulic System

Before you start the engine and use the machine, check the hydraulic system; refer to [Checking the Hydraulic System \(page 60\)](#).

## Think Safety First

Please read all safety instructions and symbols in the safety section. Knowing this information could help you or bystanders avoid injury.

### ⚠ CAUTION

This machine produces sound levels in excess of 85 dBA at the operator's ear and can cause hearing loss through extended periods of exposure.

**Wear hearing protection when operating this machine.**

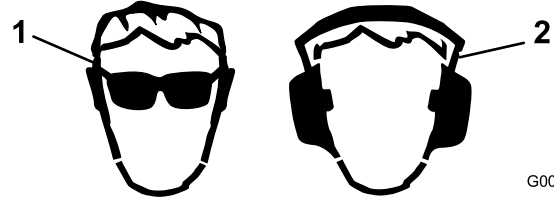

Figure 16

1. Warning— wear eye protection.
2. Warning— wear hearing protection

## Using the Safety-Interlock System

### ⚠ CAUTION

If the safety-interlock switches are disconnected or damaged the machine could operate unexpectedly and cause personal injury.

- Do not tamper with the interlock switches.
- Check the operation of the interlock switches daily and replace any damaged switches before operating the machine.

## Understanding the Safety-Interlock System

The safety-interlock system is designed to prevent the engine from starting unless the following occurs:

- You are sitting on the seat or the parking brake is engaged.
- The power takeoff (PTO) is disengaged.
- The traction pedal is in the NEUTRAL position.
- The engine temperature is below the maximum operating temperature.

The safety-interlock system also is designed to shut off the engine when the traction pedal moves from the

NEUTRAL position with the parking brake engaged. If you rise from the seat when the PTO is engaged, there is a 1-second delay and then the engine shuts off.

## Testing the Safety-Interlock System

**Service Interval:** Before each use or daily

Test the safety interlock system before you use the machine each time. If the safety system does not operate as described below, have an Authorized Service Dealer repair the safety system immediately.

1. Sitting on the seat, engage the parking brake and move the PTO to the ON position. Try starting the engine; the engine should not start.
2. Sitting on the seat, engage the parking brake and move the PTO to the OFF position. Press the traction pedal. Try starting the engine; the engine should not start.
3. Sitting on the seat, engage the parking brake, move the PTO switch to the OFF position, and allow the traction pedal to return to the NEUTRAL position. Now start the engine. While the engine is running, disengage the parking brake, engage the PTO and rise slightly from the seat. On 2-wheel-drive machines, the engine should stop within 2 seconds. On 4-wheel-drive machines, the mower deck shuts off and the engine continues to run.
4. Without sitting on the seat, engage the parking brake, move the PTO switch to the OFF position, and move the traction pedal to the NEUTRAL position. Now start the engine. While the engine is running, press the traction pedal; the engine should shut off within 2 seconds.
5. Without an operator on the seat, disengage the parking brake, move the PTO switch to off, and allow the traction pedal to return to the NEUTRAL position. Try starting the engine; the engine should not start.

## Positioning the Standard Seat

### Changing the Seat Position

The seat can move forward and backward. Position the seat where you have the best control of the machine and are most comfortable.

1. To adjust the seat, move the lever sideways to unlock the seat (Figure 17).

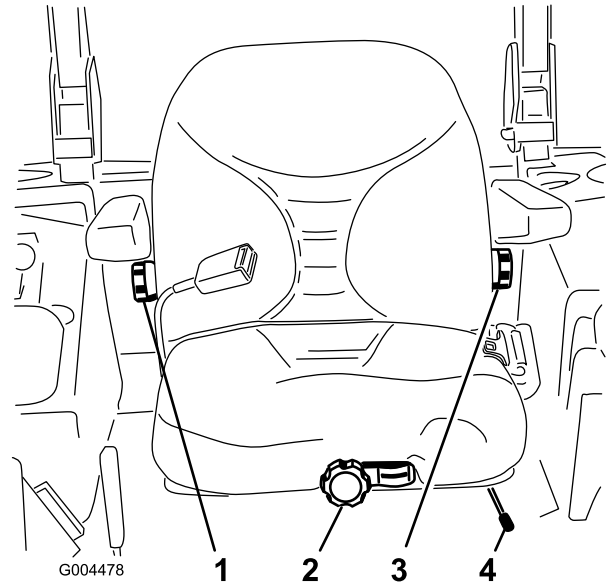

Figure 17

- |                         |                                   |
|-------------------------|-----------------------------------|
| 1. Backrest knob        | 3. Lumbar-support-adjustment knob |
| 2. Seat-suspension knob | 4. Seat-position-adjustment lever |

2. Slide the seat to the desired position and release the lever to lock the seat in position.
3. Verify that the seat has locked into place by attempting to move it back and forth.

### Changing the Seat Suspension

You can adjust the seat to provide a smooth and comfortable ride. Position the seat where you are most comfortable.

Without sitting on the seat, turn the knob in front in either direction to provide the best comfort (Figure 17).



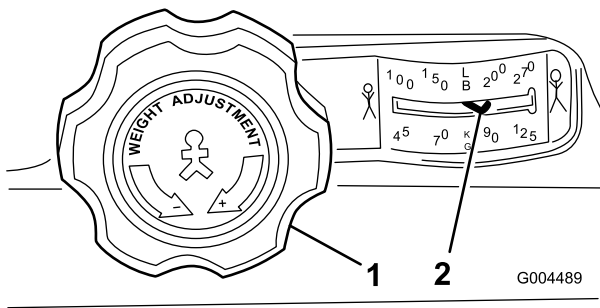

**Figure 18**

1. Seat-suspension knob
2. Operator-weight setting

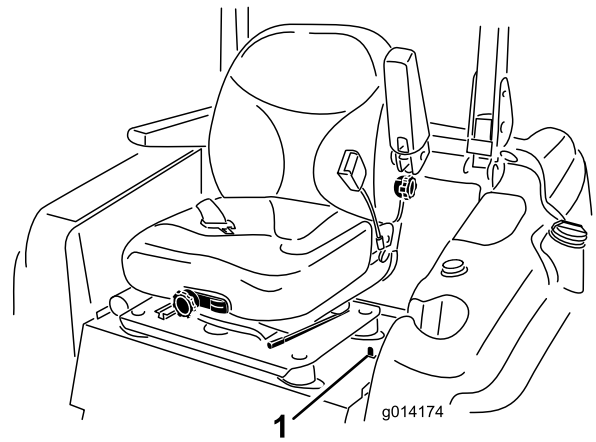

**Figure 19**

1. Seat latch
2. To lower the seat, pull up the seat-latch-release bar and lower the seat into the locked position.

## Changing the Back Position

You can adjust the back of the seat to provide a comfortable ride. Position the back of the seat where it is most comfortable.

To adjust the back of the seat, turn the knob, located under the right-side armrest, in either direction to provide the best comfort (Figure 17).

## Changing the Lumbar Support

You can adjust the back of the seat to provide a customized lumbar support for your lower back.

To adjust the back of the seat, turn the knob, under the left-side armrest, in either direction to provide the best comfort (Figure 17).

## Raising and Lowering the Seat

To access the hydraulic and other systems under the seat, you must unlatch the seat and swing it forward.

1. Move the seat latch, located on the left side of the seat, rearward to unlatch the seat and pull forward on the top of the seat (Figure 19).

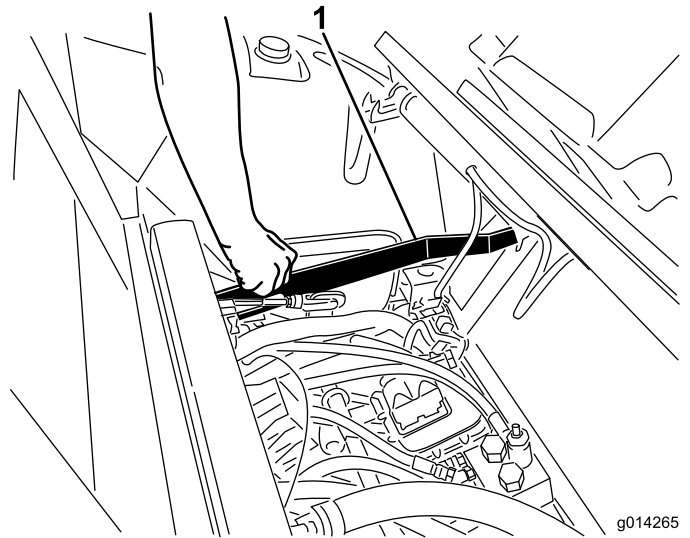

**Figure 20**

1. Seat-latch-release bar

# ***During Operation***

## **During Operation Safety**

### **General Safety**

- The owner/operator can prevent and is responsible for accidents that may cause personal injury or property damage.
- Wear appropriate clothing, including eye protection; slip-resistant, substantial foot protection; and hearing protection. Tie back long hair and do not wear jewelry.
- Do not operate the machine while ill, tired, or under the influence of alcohol or drugs.
- Never carry passengers on the machine and keep bystanders and pets away from the machine during operation.
- Operate the machine only in good visibility to avoid holes or hidden hazards.
- Avoid mowing on wet grass. Reduced traction could cause the machine to slide.
- Before you start the engine, ensure that all drives are in neutral, the parking brake is engaged, and you are in the operating position.
- Keep your hands and feet away from the cutting units. Keep clear of the discharge opening at all times.
- Look behind and down before backing up to be sure of a clear path.
- Use care when approaching blind corners, shrubs, trees, or other objects that may obscure your vision.
- Stop the blades whenever you are not mowing.
- Stop the machine and inspect the blades after striking an object or if there is an abnormal vibration in the machine. Make all necessary repairs before resuming operation.
- Slow down and use caution when making turns and crossing roads and sidewalks with the machine. Always yield the right-of-way.
- Disengage the drive to the cutting unit and shut off the engine before adjusting the height of cut (unless you can adjust it from the operating position).
- Never run an engine in an area where exhaust gasses are enclosed.
- Never leave a running machine unattended.
- Before leaving the operating position (including to empty the catchers or to unclog the chute), do the following:
  - Park the machine on level ground.
  - Disengage the power takeoff and lower the attachments.
  - Engage the parking brake.
  - Shut off the engine and remove the key from the key switch.
  - Wait for all moving parts to stop.
- Do not operate the machine when there is the risk of lightning.
- Do not use the machine as a towing vehicle.
- Use accessories, attachments, and replacement parts approved by The Toro® Company only.

### **Rollover Protection System (ROPS) Safety**

- **Do not** remove the ROPS from the machine.
- Ensure that the seat belt is attached and that you can release it quickly in an emergency.
- Check carefully for overhead obstructions and do not contact them.
- Keep the ROPS in safe operating condition by thoroughly inspecting it periodically for damage and keeping all the mounting fasteners tight.
- Replace a damaged ROPS. Do not repair or alter it.

### **Machines with Cabs**

- The ROPS is an integral and effective safety device.
- A cab installed by Toro is a roll bar.
- Always wear your seat belt.

### **Machines with a Foldable Roll Bar**

- Always use the seat belt with the roll bar in the raised position.
- The ROPS is an integral safety device. Keep a folding roll bar in the raised and locked position, and use the seat belt when operating the machine with the roll bar in the raised position.
- Lower a folding roll bar temporarily only when necessary. Do not wear the seat belt when the roll bar is folded down.
- Be aware that there is no rollover protection when a folded roll bar is in the down position.
- Check the area that you will be mowing and never fold down a folding roll bar in areas where there are slopes, drop-offs, or water.

### **Slope Safety**

- Establish your own procedures and rules for operating on slopes. These procedures must include surveying the site to determine which slopes are safe for machine operation. Always

use common sense and good judgment when performing this survey.

- Slopes are a major factor related to loss-of-control and tip-over accidents, which can result in severe injury or death. Operating the machine on any slope requires extra caution.
- Operate the machine at a lower speed when you are on a slope.
- If you feel uneasy operating the machine on a slope, do not do it.
- Watch for holes, ruts, bumps, rocks, or other hidden objects. Uneven terrain could overturn the machine. Tall grass can hide obstacles.
- Choose a low ground speed so you will not have to stop or shift while on a slope.
- A rollover can occur before the tires lose traction.
- Avoid operating the machine on wet grass. Tires may lose traction; regardless if the brakes are available and functioning.
- Avoid starting, stopping, or turning the machine on a slope.
- Keep all movement on slopes slow and gradual. Do not suddenly change the speed or direction of the machine.
- Do not operate the machine near drop-offs, ditches, embankments, or bodies of water. The machine could suddenly roll over if a wheel goes over the edge or the edge caves in. Establish a safety area between the machine and any hazard (2 machine widths).

## Using the Rollover-Protection System (ROPS)—2-Wheel Drive with ROPS and 4-Wheel Drive with ROPS Models Only

- Keep the roll bar in the raised and locked position and use the seat belt when operating the machine.
- Ensure that you can release the seat belt quickly in an emergency situation.
- Check the area that you will mow and never fold the roll bar in areas where there are slopes, drop-offs, or water.

### **⚠ WARNING**

To avoid injury or death from rollover, keep the roll bar in the raised locked position and use the seat belt.

Ensure that the seat plate is secured with the seat latch.

### **⚠ WARNING**

You have no rollover protection when the roll bar is in the down position.

- Lower the roll bar only when necessary.
- Do not wear the seat belt when the roll bar is in the down position.
- Drive slowly and carefully.
- Raise the roll bar as soon as clearance permits.
- Check carefully for overhead clearances (i.e., branches, doorways, electrical wires) before driving under any objects and do not contact them.

1. To lower the roll bar, remove the hairpin cotters, push the roll bar forward against the springs, and remove the 2 pins (Figure 21).

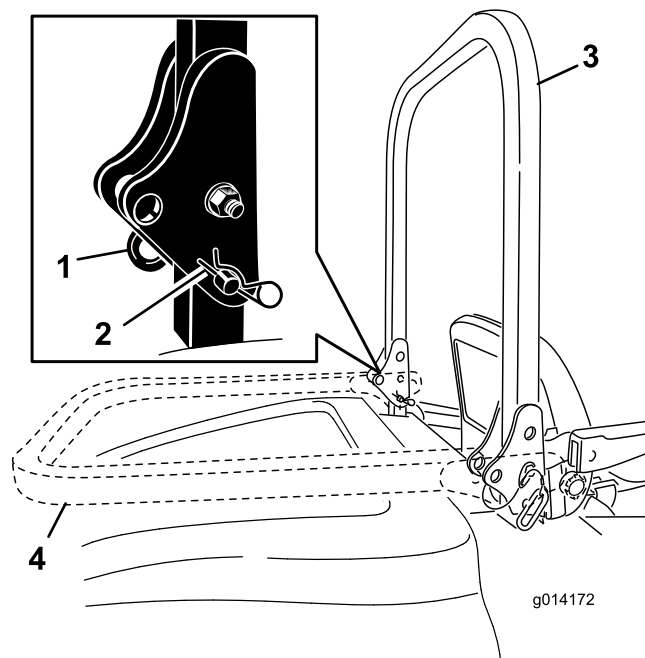

Figure 21

1. Pin
2. Hairpin cotter
3. Roll bar (raised position)
4. Roll bar (lowered position)

2. Lower the roll bar to the down position (Figure 21).

3. Install the 2 pins and secure them with the hairpin cotters (Figure 21).

**Important:** Ensure that the seat is secured with the seat latch.

4. To raise the roll bar, remove the hairpin cotter pins and remove the 2 pins (Figure 21).
5. Raise the roll bar to the upright position and install the 2 pins and secure them with the hairpin cotters (Figure 21).

**Important:** Always use the seat belt when the roll bar is in the raised and locked position. Do not use the seat belt when the roll bar is in the lowered position.

## Starting and Shutting Off the Engine

### Starting the Engine

1. Park the machine on a level surface.
2. Raise the roll bar up and lock it into place, sit on the seat, and fasten the seat belt.
3. Make sure that the traction pedal is in the NEUTRAL position.
4. Engage the parking brake.
5. Move the power-takeoff (PTO) switch to the OFF position (Figure 22).

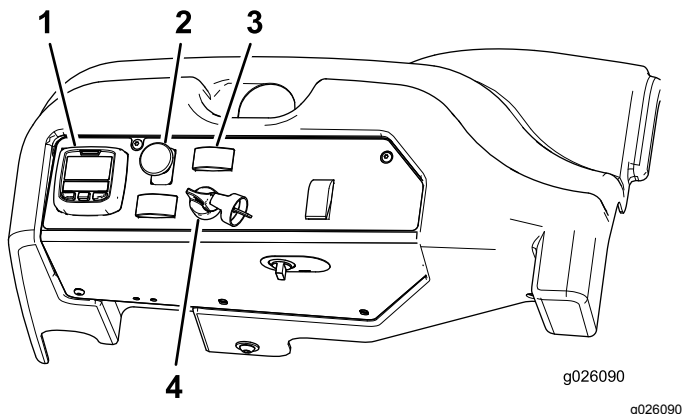

Figure 22

- |                               |                        |
|-------------------------------|------------------------|
| 1. InfoCenter                 | 3. Engine-speed switch |
| 2. Power-takeoff (PTO) switch | 4. Key switch          |

6. Turn the key clockwise to the RUN position.

**Note:** The InfoCenter glow-plug icon turns on in 6 seconds.

7. After the InfoCenter glow-plug icon goes out, turn the key to the START position. When the engine starts, release the key.

**Important:** Use starting cycles of no more than 15 seconds per minute to avoid overheating the starter motor.

**Note:** Additional starting cycles may be required when starting the engine for the first time after the fuel system has been completely drained.

**Important:** When you start the engine for the first time, or after an engine oil change or an overhaul of the engine, the transmission, or a wheel motor, operate the machine with the engine-speed switch in the Slow position in both the forward and reverse directions for 1 to 2 minutes. Also operate the deck lift switch and the PTO switch to ensure proper operation of all the parts. Then shut the engine off and check the fluid levels and check for oil leaks, loose parts, and any other noticeable malfunctions.

### Shutting Off the Engine

1. Park the machine on a level surface.
2. Disengage the PTO, make sure that the traction pedal is in the NEUTRAL position, engage the parking brake, and move the engine-speed switch to the idle position.
3. Let the engine idle for 60 seconds.
4. Turn the key to the OFF position.
5. Remove the key from the key switch before transporting or storing machine.

**Important:** Remove the key from the key switch; otherwise, the fuel pump or accessories may run and cause the battery to lose charge.

### CAUTION

Children or bystanders may be injured if they move or attempt to operate the machine while it is unattended.

Always remove the key from the key switch and engage the parking brake when leaving the machine unattended, even if just for a few minutes.

## Driving the Machine

The throttle control regulates the engine speed as measured in rpm (revolutions per minute). Place the throttle control in the FAST position for best performance. Always operate the throttle in the FAST position when mowing.

# Stopping the Machine

To stop the machine, release the traction pedal to the NEUTRAL position.

Engage the parking brake whenever you leave the machine. Remove the key from the key switch.

# Selecting the Steering Mode

For maximum trimming and minimum turf damage, operate the machine in the 4-wheel-steering mode. However, when transporting the machine on roads or trails, switch the machine into 2-wheel-steering mode.

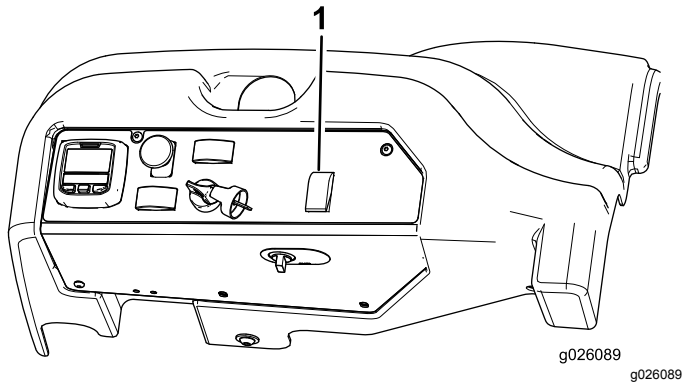

Figure 23

1. Steering selector switch

# Switching from 4-Wheel Steering to 2-Wheel Steering

Press the steering selector switch (Figure 23) to the forward position. When the wheels are not aligned in the forward position, the green light flashes and the machine remains in the 4-wheel-steering mode until the 4 tires point straight ahead. Turn the steering wheel slowly to straighten out the wheels until the green light stops flashing and remains on. When the switch light is solid green, the machine is in 2-wheel steering.

**Note:** If you turn the steering wheel too briskly, steering misalignment may occur.

# Switching from 2-Wheel Steering to 4-Wheel Steering

Press the steering selector switch (Figure 23) to the rearward position. When the front wheels are not aligned in the forward position, the green light flashes and the machine remains in 2-wheel-steering mode until the 4 tires point straight ahead. Turn the steering wheel slowly to straighten out the wheels until the green light stops flashing and remains off. When the

switch light is continuously off, the machine is in the 4-wheel-steering mode.

**Note:** If you turn the steering wheel too briskly, steering misalignment may occur.

**Note:** If the steering system is misaligned after repeated 2-wheel-steering to 4-wheel-steering engagements, refer to [Correcting Steering Misalignment](#) (page 54).

# Operating the Mower

## Raising and Lowering the Mower

The deck lift switch raises and lowers the mower deck (Figure 24). The engine must be running for you to use this switch.

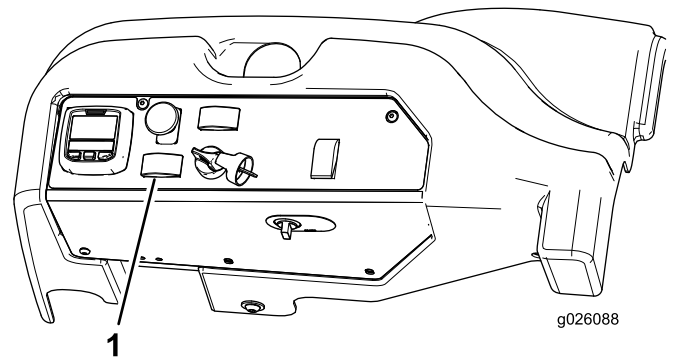

Figure 24

1. Deck lift switch

- To lower the mower deck, push the switch forward.
- To raise the mower deck, push the switch rearward.

**Important:** Do not continue to hold the switch back after the mower has fully raised. Doing so will damage the hydraulic system.

**Note:** To lock the mower deck in a raised position, raise the deck past the 15 cm (6 inch) position, remove the height-of-cut pin, and place the pin in the 15 cm (6 inches) height-of-cut position.

## Engaging the Power Takeoff (PTO)

The power-takeoff (PTO) switch starts and stops the mower blades and some powered attachments.

1. If the engine is cold, allow the engine to warm up 5 to 10 minutes before engaging the PTO.
2. While seated in the seat, make sure that the traction pedal is in the Neutral position and the engine is at full throttle.
3. Pull up on the PTO switch to engage it (Figure 25).

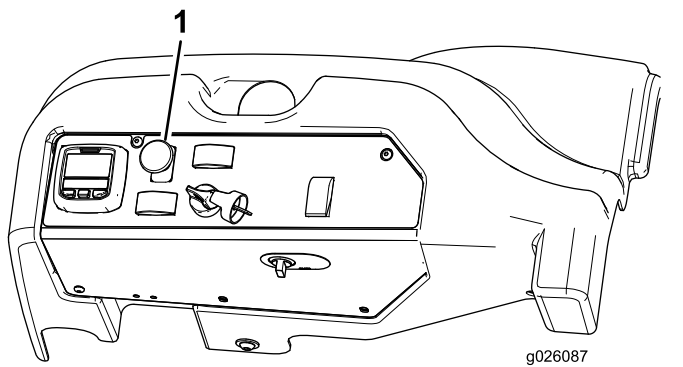

**Figure 25**

1. PTO switch

## Disengaging the PTO

To disengage the PTO, push the switch to the OFF position.

## Adjusting the Height of Cut

You can adjust the height of cut from 2.5 to 15.8 cm (1 to 6 inches) in 6 mm (1/4 inch) increments by relocating the height-of-cut pin into different hole locations.

1. With the engine running, push back the deck-lift switch until the mower deck is fully raised, and **release the switch immediately** as shown in [Figure 26](#).
2. Rotate the height-of-cut pin until the nub on it lines up with the slots in the holes in the height-of-cut bracket and remove it ([Figure 26](#)).
3. Select a hole in the height-of-cut bracket corresponding to the desired height of cut, insert the pin, and rotate it down to lock it in place ([Figure 26](#)).

**Note:** There are 4 rows of hole positions ([Figure 26](#)). The top row gives you the height of cut listed above the pin. The second row down gives you the height listed plus 6 mm (1/4 inch). The third row down gives you the height listed plus 12 mm (1/2 inch). The bottom row gives you the height listed plus 18 mm (3/4 inch). For the 15.8 cm (6 inches) position, there is only 1 hole, located in the second row. This does not add 6 mm (1/4 inch) to the 15.8 cm (6 inches) position.

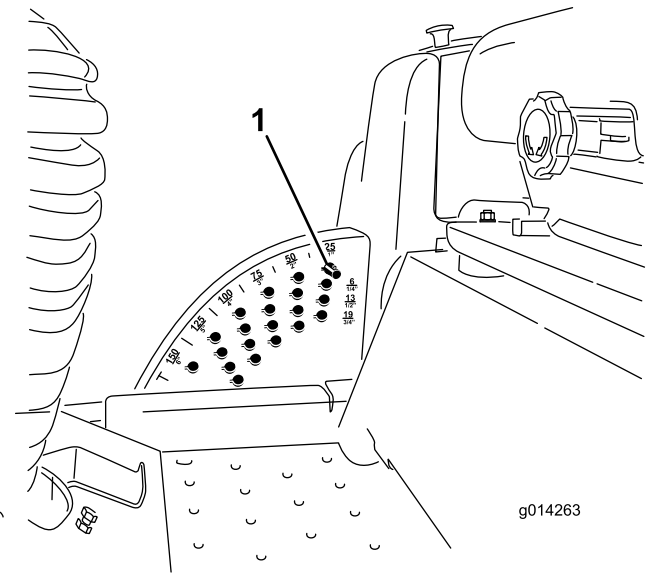

**Figure 26**

1. Height-of-cut pin

4. Adjust the anti-scalp rollers and skids as required.

## Cutting Grass with the Machine

**Note:** Cutting grass at a rate that loads the engine promotes DPF regeneration.

1. Move the machine to the job site.
2. Whenever possible, set the engine-speed switch to high idle.
3. Engage the PTO switch.
4. Gradually move the traction pedal forward and slowly drive the machine over the mowing area.
5. Once the front of the cutting units are over the mowing area, lower the cutting units.
6. Cut grass so that the blades can cut and discharge clippings at a high rate while producing a good quality of cut.

**Note:** If the cutting rate is too high, the quality of cut may deteriorate. Reduce the ground speed of the machine or reduce the width of cut to regain high idle engine speed.

7. When the cutting units are over the far edge of the mowing area, lift the cutting units.
8. Perform a tear-shaped turn to quickly line up for your next pass.

# Diesel Particulate Filter Regeneration

The diesel particulate filter (DPF) is part of the exhaust system. The diesel-oxidation catalyst of the DPF reduces harmful gasses and the soot filter removes soot from the engine exhaust.

The DPF regeneration process uses heat from the engine exhaust to incinerate the soot accumulated on the soot filter, converting the soot to ash, and clears the channels of the soot filter so that filtered engine exhaust flows out the DPF.

The engine computer monitors the accumulation of soot by measuring the back pressure in the DPF. If the back pressure is too high, soot is not incinerating in the soot filter through normal engine operation. To keep the DPF clear of soot, remember the following:

- Passive regeneration occurs continuously while the engine is running—run the engine at full engine speed when possible to promote DPF regeneration.
- If the back pressure is too high, the engine computer signals you through the InfoCenter when additional processes (assist and reset regeneration) are running.
- Allow the assist and reset regeneration process to complete before shutting off the engine.

Operate and maintain your machine with the function of the DPF in mind. Engine load at high idle engine speed generally produce adequate exhaust temperature for DPF regeneration.

## Engine Warning Messages—Soot Accumulation

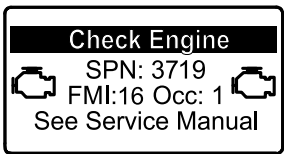
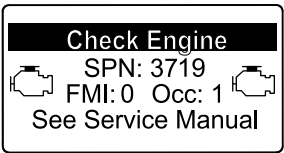
Indication Level	Fault Code	Engine Power Rating	Recommended Action
Level 1: Engine Warning	 <p><b>Figure 27</b> Check Engine SPN 3719, FMI 16</p>	The computer de-rates the engine power to 85%	Perform a parked regeneration as soon as possible; refer to <a href="#">Parked Regeneration (page 35)</a> .
Level 2: Engine Warning	 <p><b>Figure 28</b> Check Engine SPN 3719, FMI 0</p>	The computer de-rates the engine power to 50%	Perform a recovery regeneration as soon as possible; refer to <a href="#">Recovery Regeneration (page 38)</a> .

**Important:** Minimize the amount of time that you idle the engine or operate the engine at low-engine speed to help reduce the accumulation of soot in the soot filter.

### ⚠ CAUTION

The exhaust temperature is hot (approximately 600°C (1112°F) during DPF parked regeneration or recovery regeneration. Hot exhaust gas can harm you or other people.

- Never operate the engine in an enclosed area.
- Make sure that there are no flammable materials around the exhaust system.
- Never touch a hot exhaust system component.
- Never stand near or around the exhaust pipe of the machine.



## DPF Soot Accumulation

- Over time, the DPF accumulates soot in the soot filter. The computer for the engine monitors the soot level in the DPF.
- When enough soot accumulates, the computer informs you that it is time to regenerate the diesel particulate filter.
- DPF regeneration is a process that heats the DPF to convert the soot to ash.
- In addition to the warning messages, the computer reduces the power produced by the engine at different soot-accumulation levels.

# DPF Ash Accumulation

- The lighter ash is discharged through the exhaust system; the heavier ash collects in the soot filter.
- Ash is a residue of the regeneration process. Over time, the diesel particulate filter accumulates ash that does not discharge with the engine exhaust.
- The computer for the engine calculates the amount of ash accumulated in the DPF.
- When enough ash accumulates, the engine computer sends information to the InfoCenter in the form of a system advisory or an engine fault to indicate the accumulation of ash in the DPF.
- The advisory and faults are indications that it is time to service the DPF.
- In addition to the warnings, the computer reduces the power produced by the engine at different ash-accumulation levels.

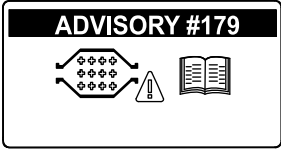
## InfoCenter Advisory and Engine Warning Messages—Ash Accumulation

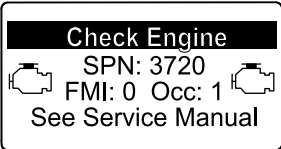
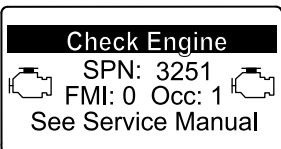
Indication Level	Advisory or Fault Code	Engine Speed Reduction	Engine Power Rating	Recommended Action
Level 1: System Advisory	 <p style="text-align: center;">g213865 <b>Figure 29</b> Advisory #179</p>	None	100%	Notify your service department that advisory #179 displays in the InfoCenter.
Level 2: Engine Warning	 <p style="text-align: center;">g213863 <b>Figure 30</b> Check Engine SPN 3720, FMI 16</p>	None	The computer de-rates the engine power to 85%	Service the DPF; refer to <a href="#">Servicing the Diesel-Oxidation Catalyst (DOC) and the Soot Filter (page 50)</a>
Level 3: Engine Warning	 <p style="text-align: center;">g213864 <b>Figure 31</b> Check Engine SPN 3720, FMI 0</p>	None	The computer de-rates the engine power to 50%	Service the DPF; refer to <a href="#">Servicing the Diesel-Oxidation Catalyst (DOC) and the Soot Filter (page 50)</a>
Level 4: Engine Warning	 <p style="text-align: center;">g214715 <b>Figure 32</b> Check Engine SPN 3251, FMI 0</p>	Engine speed at max torque + 200 rpm	The computer de-rates the engine power to 50%	Service the DPF; refer to <a href="#">Servicing the Diesel-Oxidation Catalyst (DOC) and the Soot Filter (page 50)</a>



# Types of Diesel Particulate Filter Regeneration

## Types of diesel particulate filter regeneration that are performed while the machine is operating:

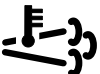
Type of Regeneration	Conditions for DPF regeneration	DPF description of operation
<b>Passive</b>	Occurs during normal operation of the machine at high-engine speed or high-engine load	<p>The InfoCenter does not display an icon indicating passive regeneration.</p> <p>During passive regeneration, the DPF processes high-heat exhaust gasses; oxidizing harmful emissions and burning soot to ash.</p> <p>Refer to <a href="#">Passive DPF Regeneration (page 34)</a>.</p>
<b>Assist</b>	Occurs as a result of low-engine speed, low-engine load, or after the computer detects back pressure in the DPF	<p>When the assist/reset-regeneration icon  is displayed in the InfoCenter, an assist regeneration is in progress.</p> <p>During assist regeneration, the computer controls the intake throttle to increase the exhaust temperature, enabling assist regeneration to occur.</p> <p>Refer to <a href="#">Assist DPF Regeneration (page 34)</a>.</p>
<b>Reset</b>	<p>Occurs after assist regeneration only if the computer detects that assist regeneration did not sufficiently reduce the soot level</p> <p>Also occurs every 100 hours to reset baseline sensor readings</p>	<p>When the assist/reset-regeneration icon  is displayed in the InfoCenter, a regeneration is in progress.</p> <p>During reset regeneration, the computer controls the intake throttle and fuel injectors to increase the exhaust temperature during regeneration.</p> <p>Refer to <a href="#">Reset Regeneration (page 35)</a>.</p>

## Types of diesel particulate filter regeneration that require you to park the machine:

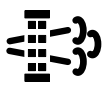
Type of Regeneration	Conditions for DPF regeneration	DPF description of operation
<b>Parked</b>	<p>Soot buildup occurs as a result of prolonged operation at low-engine speed or low-engine load. May also occur as a result of using incorrect fuel or oil</p> <p>The computer detects back pressure due to soot buildup and requests a parked regeneration</p>	<p>When the parked-regeneration icon  is displayed in the InfoCenter, a regeneration is requested.</p> <ul style="list-style-type: none"> <li>• Perform the parked regeneration as soon as possible to avoid needing a recovery regeneration.</li> <li>• A parked regeneration requires 30 to 60 minutes to complete.</li> <li>• You must have at least a 1/4 tank of fuel in the tank.</li> <li>• You must park the machine to perform a recovery regeneration.</li> </ul> <p>Refer to <a href="#">Parked Regeneration (page 35)</a>.</p>

## Types of diesel particulate filter regeneration that require you to park the machine: (cont'd.)

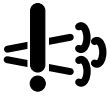
Type of Regeneration	Conditions for DPF regeneration	DPF description of operation
<b>Recovery</b>	Occurs as a result of ignoring parked regeneration requests and continuing operation, adding more soot when the DPF is already in need of a parked regeneration	 <p>When the recovery-regeneration icon is displayed in the InfoCenter, a recovery regeneration is requested.</p> <p>Contact your Authorized Toro Distributor to have a service technician perform the recovery regeneration.</p> <ul style="list-style-type: none"> <li>• A recovery regeneration requires up to 4 hours to complete.</li> <li>• You must have at least a 1/2 tank of fuel in the machine.</li> <li>• You must park the machine to perform a recovery regeneration.</li> </ul> <p>Refer to <a href="#">Recovery Regeneration (page 38)</a>.</p>

## Passive DPF Regeneration

- Passive regeneration occurs as part of normal engine operation.
- While operating the machine, run the engine at full-engine speed when possible to promote DPF regeneration.

- While operating the machine, run the engine at full engine speed when possible to promote DPF regeneration.

## Assist DPF Regeneration

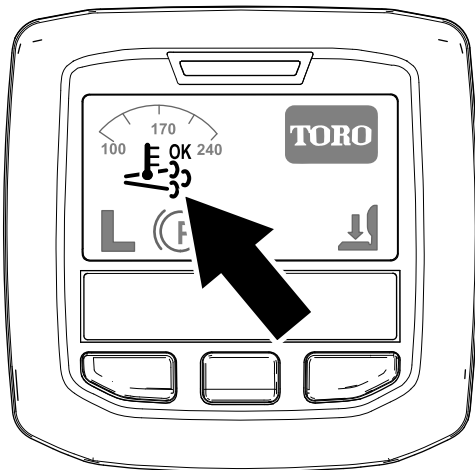

**Figure 33**

Assist/reset-regeneration icon

g214711

- The  icon displays in the InfoCenter while the assist regeneration is processing.
- Whenever possible, do not shut off the engine or reduce engine speed while the assist regeneration is processing.

**Important:** Allow the machine to complete the assist regeneration process before shutting off the engine.

**Note:** The assist regeneration is finished

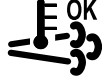
processing when the  icon disappears from the InfoCenter.

- The assist/reset-regeneration icon displays in the InfoCenter ([Figure 33](#)).
- The computer takes control of the intake throttle to increase the temperature of the engine exhaust.

## Reset Regeneration

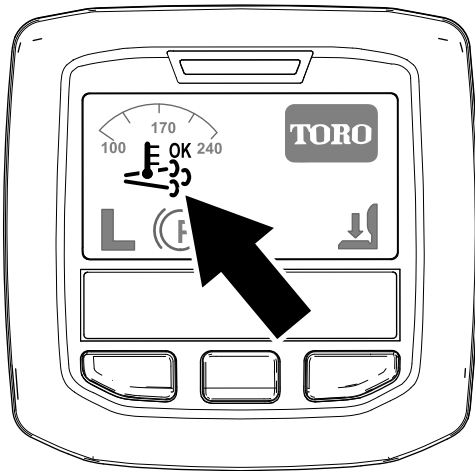

g214711

**Figure 34**

Assist/reset-regeneration icon

## Parked Regeneration

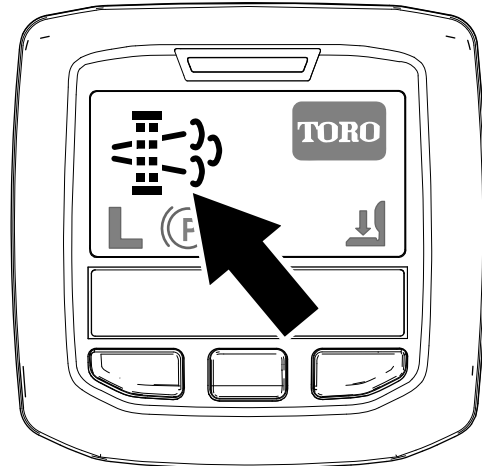

g214713

**Figure 35**

Parked-regeneration request icon

- The assist/reset-regeneration icon displays in the InfoCenter (Figure 34).
- The computer takes control of the intake throttle and changes the fuel injection operation to increase the temperature of the engine exhaust.

**Important:** The assist/reset-regeneration icon indicates that the exhaust temperature discharged from of your machine may be hotter than during regular operation.

- While operating the machine, run the engine at full engine speed when possible to promote DPF regeneration.

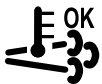

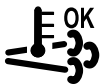
- The  icon displays in the InfoCenter while the reset regeneration is processing.
- Whenever possible, do not shut off the engine or reduce engine speed while the reset regeneration is processing.

**Important:** Allow the machine to complete the reset regeneration process before shutting off the engine.

**Note:** The reset regeneration is finished

processing when the  icon disappears from the InfoCenter.

- The parked-regeneration requested icon displays in the InfoCenter (Figure 35).
- If a parked regeneration is needed, the InfoCenter displays engine warning SPN 3719, FMI 16 (Figure 36) and the engine computer derates engine power to 85%.

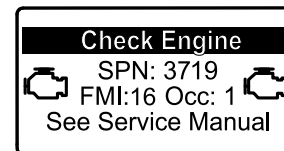

g213866

**Figure 36**

**Important:** If you do not complete a parked regeneration within 2 hours, the engine computer derates engine power to 50%.

- A parked regeneration requires 30 to 60 minutes to complete.
- If you are authorized by your company, you need the PIN code to perform the parked-regeneration process.

### Preparing to Perform a Parked or Recovery Regeneration

1. Ensure that the machine has at least 1/4 tank of fuel.
2. Move the machine outside to an area away from combustible materials.
3. Park the machine on a level surface.
4. Ensure that the traction control or motion-control levers are in the NEUTRAL position.
5. If applicable, lower the cutting units and shut them off.

6. Engage the parking brake.
7. Set the throttle to the low IDLE position.

## Performing a Parked Regeneration

**Note:** For instructions on unlocking protected menus, refer to [Accessing Protected Menus \(page 18\)](#).

1. Access the protected menu and unlock the protected settings submenu ([Figure 37](#)); refer to [Accessing Protected Menus \(page 18\)](#).

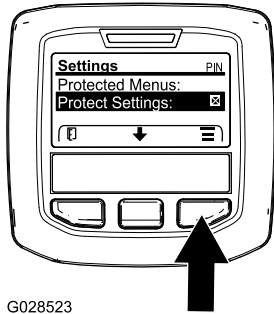

G028523

**Figure 37**

g028523

2. Navigate to the MAIN MENU, press the center button to scroll down to the SERVICE MENU, and press the right button to select the SERVICE option ([Figure 38](#)).

**Note:** The InfoCenter should display the PIN indicator in the upper right corner of the display.

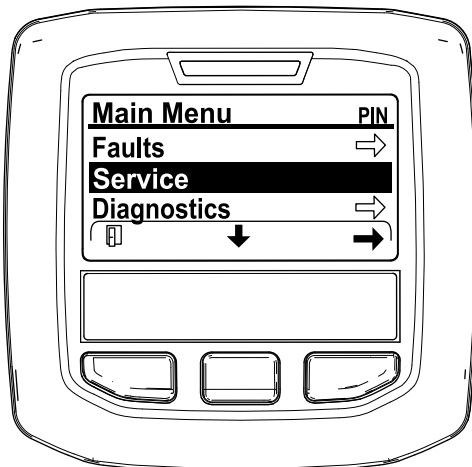

**Figure 38**

g212371

3. In the SERVICE MENU, press the middle button until the DPF REGENERATION options displays, and press the right button to select the DPF REGENERATION option ([Figure 39](#)).

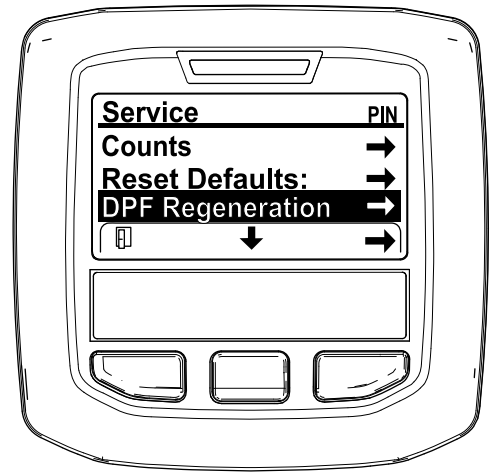

**Figure 39**

g212138

4. When the "Initiate DPF Regen. Are you sure?" message displays, press the center button ([Figure 40](#)).

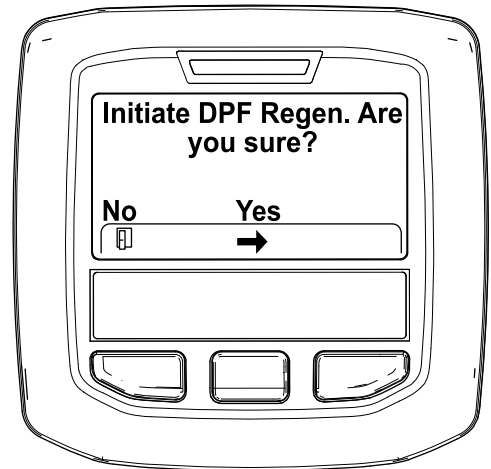

**Figure 40**

g212125

5. If the coolant temperature is below 60°C (140°F) the "Insure  is running and above 60C/140F" message displays. ([Figure 41](#)).

Observe the temperature in the display, and run the machine at full throttle until the temperature reaches 60°C (140°F), then press the center button.

**Note:** If the coolant temperature is above 60°C (140°F) this screen is skipped.

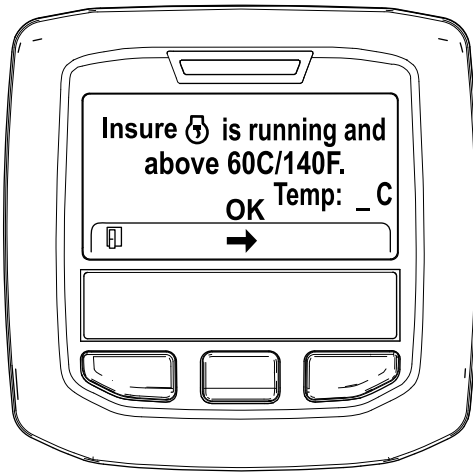

Figure 41

g211986

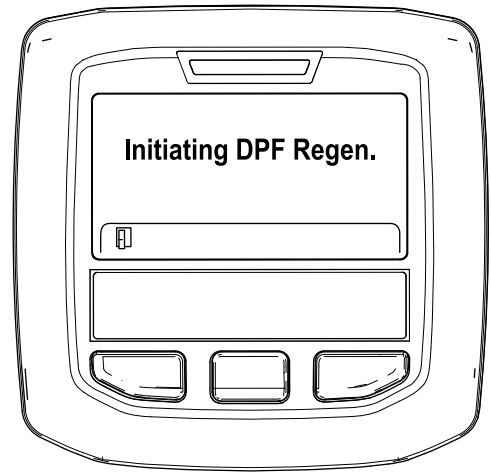

Figure 43

g212405

6. Move the throttle control to LOW IDLE and press the center button (Figure 42).

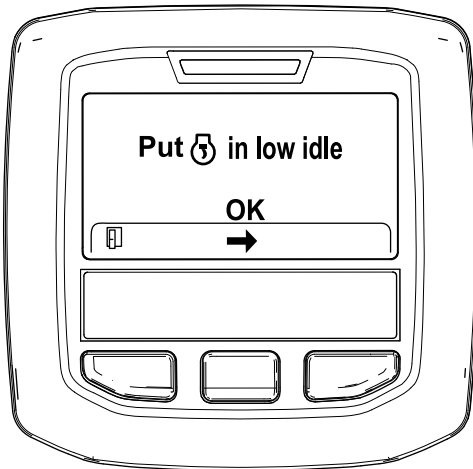

Figure 42

g212372

- B. The "Waiting on [engine icon]" message displays (Figure 44).



Figure 44

g212406

7. The following messages display as the parked regeneration process begins:

- A. The "Initiating DPF Regen." message displays (Figure 43).

- C. The computer determines whether the regeneration runs. One of the following messages displays in the InfoCenter:
- If the regeneration is allowed, the "Regen Initiated. Allow up to 30 minutes for completion" message displays in the InfoCenter, wait for the machine to complete the parked regeneration process (Figure 45).

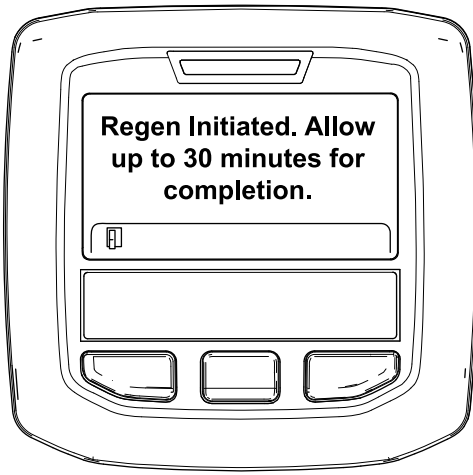

Figure 45

g213424



The engine is cold—wait.



The engine is warm—wait.



30%

The engine hot—regeneration in progress (percent complete).

9. The parked regeneration is complete when the “Regen Complete” message displays in the InfoCenter. Press the left button to exit to the home screen (Figure 47).

- If the regeneration process is not allowed by the engine computer, the “DPF Regen Not Allowed” message displays in the InfoCenter (Figure 46). Press the left button to exit to the home screen

**Important:** If you did not meet all the requirements for regeneration or if less than 50 hours have passed since the last regeneration, the “DPF Regen Not Allowed” message appears.

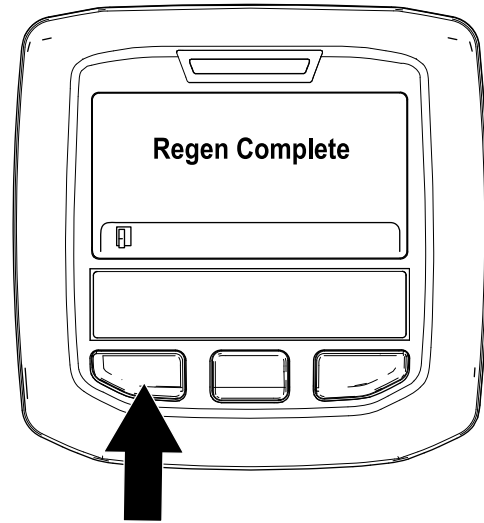

Figure 47

g212404

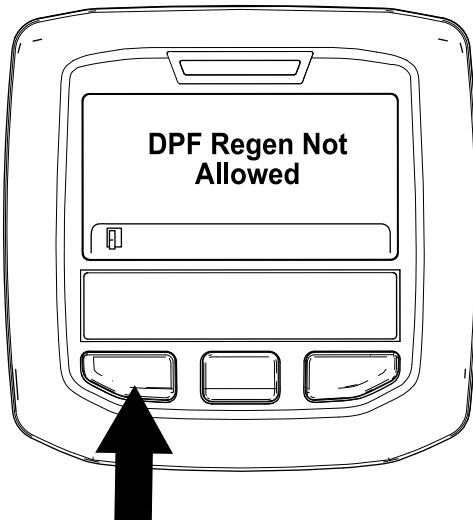

Figure 46

g212410

8. While the regeneration is running, the InfoCenter returns to the home screen and shows the following icons:

## Recovery Regeneration

- If you ignore the request for a parked regeneration (displayed in the InfoCenter) and continue to operate the machine, a critical amount of soot builds up in the DPF.
- If a recovery regeneration is needed, the InfoCenter displays engine warning SPN 3719, FMI 16 (Figure 48) and the engine computer derates engine power to 85%.

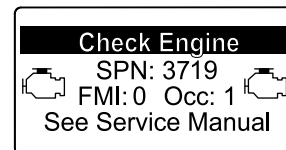

Figure 48

g213867

**Important:** If you do not complete a recovery regeneration within 15 minutes, the engine computer derates engine power to 50%.

- Perform a recovery-regeneration whenever there is a loss of engine power and a parked regeneration cannot effectively clean the DPF of soot.
- A recovery regeneration requires up to 4 hours to complete.
- You need a distributor technician to perform the recovery regeneration process; contact your Authorized Toro Distributor.

## Operating Tips

### Using the Fast Throttle Setting

To maintain enough power for the machine and deck while mowing, operate the engine at the fast throttle position and adjust your ground speed for conditions.

### Selecting the Ground Speed

To improve cut quality, use a slower ground speed. Decrease the ground speed as the load on the cutting blades increases, and increase ground speed as load on the blades decreases.

### Alternating Mowing Direction

Alternate mowing direction to avoid making ruts in the turf over time. This also helps disperse clippings which enhances decomposition and fertilization.

### Avoiding Cutting Too Low

If the cutting width of the mower is wider than the mower you previously used, raise the cutting height to ensure that uneven turf is not cut too short.

### Selecting the Proper Height of Cut to Suit Conditions

Remove approximately 25 mm (1 inch) or no more than 1/3 of the grass blade when cutting. In exceptionally lush and dense grass, you may have to slow down the forward speed and/or raise the height of cut to the next higher setting.

**Important:** If cutting more than 1/3 of the grass blade off, or in sparse long grass or dry conditions, the use of flat sail blades is recommended to reduce air-borne chaff, debris, and unnecessary strain on deck-drive components.

### Cutting Long Grass

If the grass is ever allowed to grow slightly longer than normal, or if it contains a high degree of moisture,

raise the cutting height higher than usual and cut the grass at this setting. Then cut the grass again using the lower, normal setting.

## Keeping the Mower Clean

Clean clippings and dirt from the underside of the mower after each use. If grass and dirt build up inside the mower, cutting quality will eventually become unsatisfactory.

To reduce the risk of fire, keep the engine, muffler, battery compartment, parking brake, cutting units, and fuel storage compartment free of grass, leaves, or excessive grease. Clean up any spilled oil or fuel.

## Maintaining the Blades

Maintain sharp blades throughout the cutting season because sharp blades cut cleanly without tearing or shredding the grass blades. Tearing and shredding turns grass brown at the edges, which slows growth and increases the chance of disease. Check the blades daily for sharpness and for any wear or damage. Sharpen the blades as necessary. If a blade is damaged or worn, replace it immediately with a genuine Toro replacement blade. Refer to Servicing the Cutting Blades in the mower-deck manual.

# After Operation

## After Operation Safety

- Clean grass and debris from the cutting units, mufflers, and engine compartment to help prevent fires. Clean up oil or fuel spills.
- If the cutting units are in the transport position, use the positive mechanical lock (if available) before you leave the machine unattended.
- Allow the engine to cool before storing the machine in any enclosure.
- Shut off the fuel before storing or transporting the machine.
- Never store the machine or fuel container where there is an open flame, spark, or pilot light, such as on a water heater or on other appliances.
- Keep all parts of the machine in good working condition and all hardware tightened, especially blade-attachment hardware.
- Replace all worn or damaged decals.

## Pushing the Machine by Hand

If the machine stalls or runs out of fuel, you may need to push it. You must first open both of the hydraulic bypass valves.

**Important:** Always push the machine by hand and never a long distance. Never tow the machine, because damage to the hydraulic system may occur.

## Pushing the Machine

1. Disengage the power takeoff (PTO), turn the key to the OFF position, and engage the parking brake.
2. Remove the key from the key switch. **You must open both bypass valves.**
3. Lift the seat.
4. Rotate each bypass valve counterclockwise 1 turn (Figure 49).

**Note:** This allows hydraulic fluid to bypass the pump, enabling the wheels to turn.

**Important:** Do not rotate the bypass valves more than 1 turn. This prevents the valves from coming out of the body and causing fluid to run out.

5. Disengage the parking brake before pushing the machine.

## Changing to Machine Operation

1. Rotate each bypass valve clockwise 1 turn and hand tighten them (Figure 49).
- Note:** Do not overtighten the bypass valves.
2. Torque the valves approximately 8 N·m (71 in-lb) as shown in Figure 49.

**Note:** The machine does not drive unless the bypass valves are turned in.

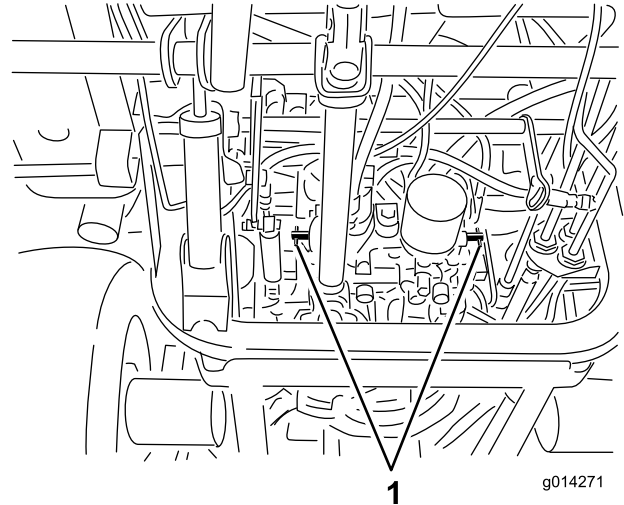

Figure 49

1. Bypass valves

## Hauling the Machine

- Use care when loading or unloading the machine into a trailer or a truck.
- Use full-width ramps for loading the machine into a trailer or a truck.
- Tie the machine down securely using straps, chains, cable, or ropes. Both front and rear straps should be directed down and outward from the machine.



# Locating the Tie-Down Points

There are tie downs located at the front and rear sides of the machine (Figure 50).

**Note:** Use properly-rated DOT-approved straps in 4 corners to tie down the machine.

- 2 on the front of the operator's platform
- Rear tire

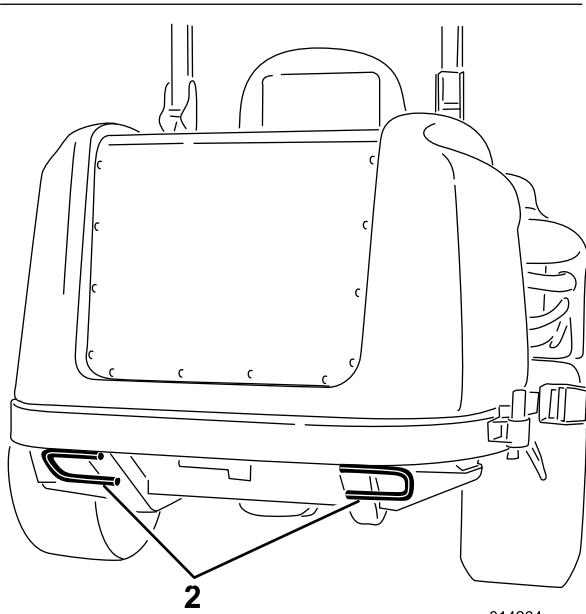
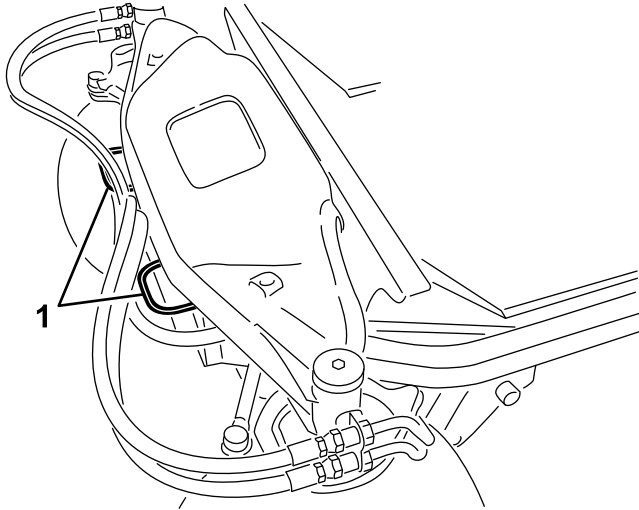

g014264

g014264

**Figure 50**

1. Tie-down point

# Maintenance

**Note:** Determine the left and right sides of the machine from the normal operating position.

## Recommended Maintenance Schedule(s)

Maintenance Service Interval	Maintenance Procedure
After the first 10 hours	<ul style="list-style-type: none"> <li>• Check the tension of the alternator belt.</li> <li>• Torque the wheel lug nuts.</li> </ul>
After the first 200 hours	<ul style="list-style-type: none"> <li>• Change the hydraulic fluid and filter.</li> </ul>
Before each use or daily	<ul style="list-style-type: none"> <li>• Test the safety system.</li> <li>• Check the air-cleaner indicator.</li> <li>• Drain water or other contaminants from the water separator.</li> <li>• Check the engine-coolant level.</li> <li>• Clean the radiator with compressed air (do not use water). Clean the radiator more frequently in extremely dusty and dirty conditions.</li> <li>• Check the level of the hydraulic fluid.</li> </ul>
Every 50 hours	<ul style="list-style-type: none"> <li>• Grease the bearing and bushing grease fittings. Grease the bearing and bushing grease fittings more frequently in extremely dusty and dirty conditions.</li> <li>• Check the connections of the battery cable.</li> <li>• Check the tire pressure.</li> <li>• Clean the air-conditioning coil. Clean the air-conditioning coil more frequently in extremely dusty or dirty conditions.</li> </ul>
Every 100 hours	<ul style="list-style-type: none"> <li>• Check the tension of the alternator belt.</li> </ul>
Every 200 hours	<ul style="list-style-type: none"> <li>• Inspect the cooling-system hoses and seals. Replace them if they are cracked or torn.</li> <li>• Torque the wheel lug nuts.</li> </ul>
Every 250 hours	<ul style="list-style-type: none"> <li>• Change the engine oil and filter.</li> <li>• Clean the cab air filters. Replace the cab air filters if they are torn or excessively dirty.</li> </ul>
Every 400 hours	<ul style="list-style-type: none"> <li>• Service the air cleaner (earlier if the air cleaner indicator shows red, and more frequently in extremely dirty or dusty conditions).</li> <li>• Replace the fuel-filter canister.</li> <li>• Replace the engine fuel filter.</li> <li>• Check the fuel lines and connections.</li> </ul>
Every 800 hours	<ul style="list-style-type: none"> <li>• Change the hydraulic fluid and filter.</li> <li>• Inspect the engine valve clearance; refer to your engine owner's manual.</li> </ul>
Every 1,500 hours	<ul style="list-style-type: none"> <li>• Replace any moving hoses.</li> </ul>
Every 6,000 hours	<ul style="list-style-type: none"> <li>• Disassemble, clean, and assemble the soot filter of the DPF, or clean the soot filter if engine faults SPN 3720 FMI 16, SPN 3720 FMI 0, or SPN 3720 FMI 16 display in the InfoCenter.</li> </ul>
Every 2 years	<ul style="list-style-type: none"> <li>• Flush and replace the cooling-system fluid.</li> </ul>

**Important:** Refer to your engine owner's manual for additional maintenance procedures. A detailed Service Manual is also available for purchase from your Authorized Toro Distributor.

**Note:** To obtain an electrical schematic or a hydraulic schematic for your machine, visit [www.Toro.com](http://www.Toro.com).

# Daily Maintenance Checklist

Duplicate this page for routine use.

Maintenance Check Item	For the week of:						
	Monday	Tuesday	Wednesday	Thursday	Friday	Saturday	Sunday
Check the safety-interlock operation.							
Check the brake operation.							
Check the engine-oil level.							
Check the cooling-system-fluid level.							
Drain the water/fuel separator.							
Check the air filter, dust cup, and burp valve.							
Check for unusual engine noises. <sup>2</sup>							
Check the radiator and screen for debris							
Check for unusual operating noises.							
Check the hydraulic-system-oil level.							
Check the hydraulic hoses for damage.							
Check for fluid leaks.							
Check the fuel level.							
Check the tire pressure.							
Check the instrument operation.							
Check the height-of-cut adjustment.							
Lubricate all the grease fittings. <sup>2</sup>							
Touch up any damaged paint.							
Check the air-filter restriction indicator <sup>3</sup>							

<sup>1</sup>Check the glow plug and injector nozzles if starting is hard, there is excess smoke, or the engine is running rough.

<sup>2</sup>Immediately **after every** washing, regardless of the interval listed

<sup>3</sup>If the indicator shows red

## Notation for Areas of Concern

Inspection performed by:		
<b>Item</b>	<b>Date</b>	<b>Information</b>

### **⚠ CAUTION**

If you leave the key in the key switch, someone could accidentally start the engine and seriously injure you or other bystanders.

Remove the key from the key switch before you do any maintenance.

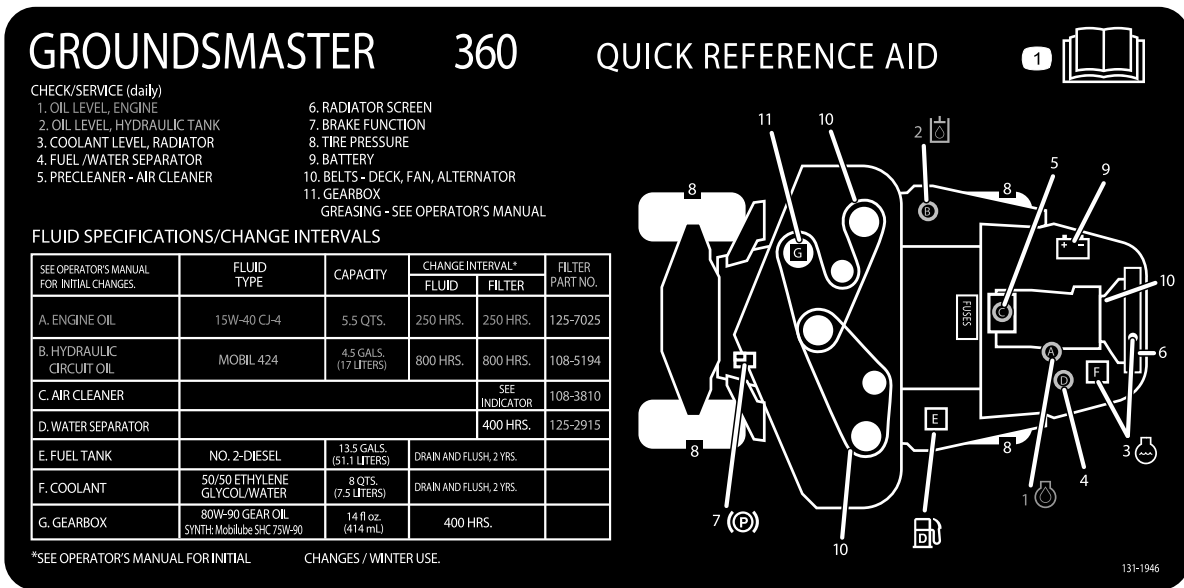

**Figure 51**  
Service Interval Chart

decal131-1946

## Pre-Maintenance Procedures

### Pre-Maintenance Safety

- Before adjusting, cleaning, repairing, or leaving the machine, do the following:
  - Park the machine on a level surface.
  - Move the throttle switch to the low-idle position.
  - Disengage the cutting units.
  - Lower the cutting units.
  - Ensure that the traction is in neutral.
  - Engage the parking brake.
- Shut off the engine and remove the key.
- Wait for all moving parts to stop.
- Allow machine components to cool before performing maintenance.
- If the cutting units are in the transport position, use the positive mechanical lock (if available) before you leave the machine unattended.
- If possible, do not perform maintenance while the engine is running. Keep away from moving parts.
- Use jack stands to support the machine or components when required.
- Carefully release pressure from components with stored energy.

# Preparing the Machine for Maintenance

1. Ensure that the PTO is disengaged.
2. Park the machine on a level surface.
3. Engage the parking brake.
4. Lower the mower deck(s) if necessary.
5. Shut off the engine and wait for all moving parts to stop.
6. Turn the key to the STOP position and remove it.
7. Allow machine components to cool before performing maintenance.

## Using the Hood-Prop Rod

1. Release the hood latches.
2. Lift up the hood until you can position the prop rod behind the frame tube (Figure 52).
3. Lower the hood until the prop rod is in front of and resting against the frame tube.
4. To lower the hood, raise the hood until you can raise the prop rod above the frame tube, then lower the hood.
5. Secure the hood latches.

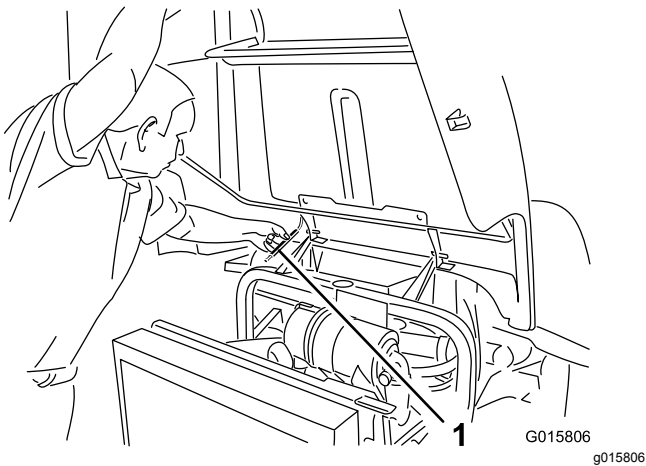

**Figure 52**

1. Prop rod
-

# Lubrication

## Greasing the Bearings and Bushings

**Service Interval:** Every 50 hours Grease the bearing and bushing grease fittings more frequently in extremely dusty and dirty conditions.

The machine has grease fittings that you must lubricate regularly with No. 2 lithium grease. Lubricate the grease fittings immediately after every washing, regardless of interval specified.

1. Wipe the grease fittings clean so that foreign matter cannot be forced into the bearing or bushing ([Figure 53](#)).
2. Pump the grease into the fittings.
3. Wipe off any excess grease.

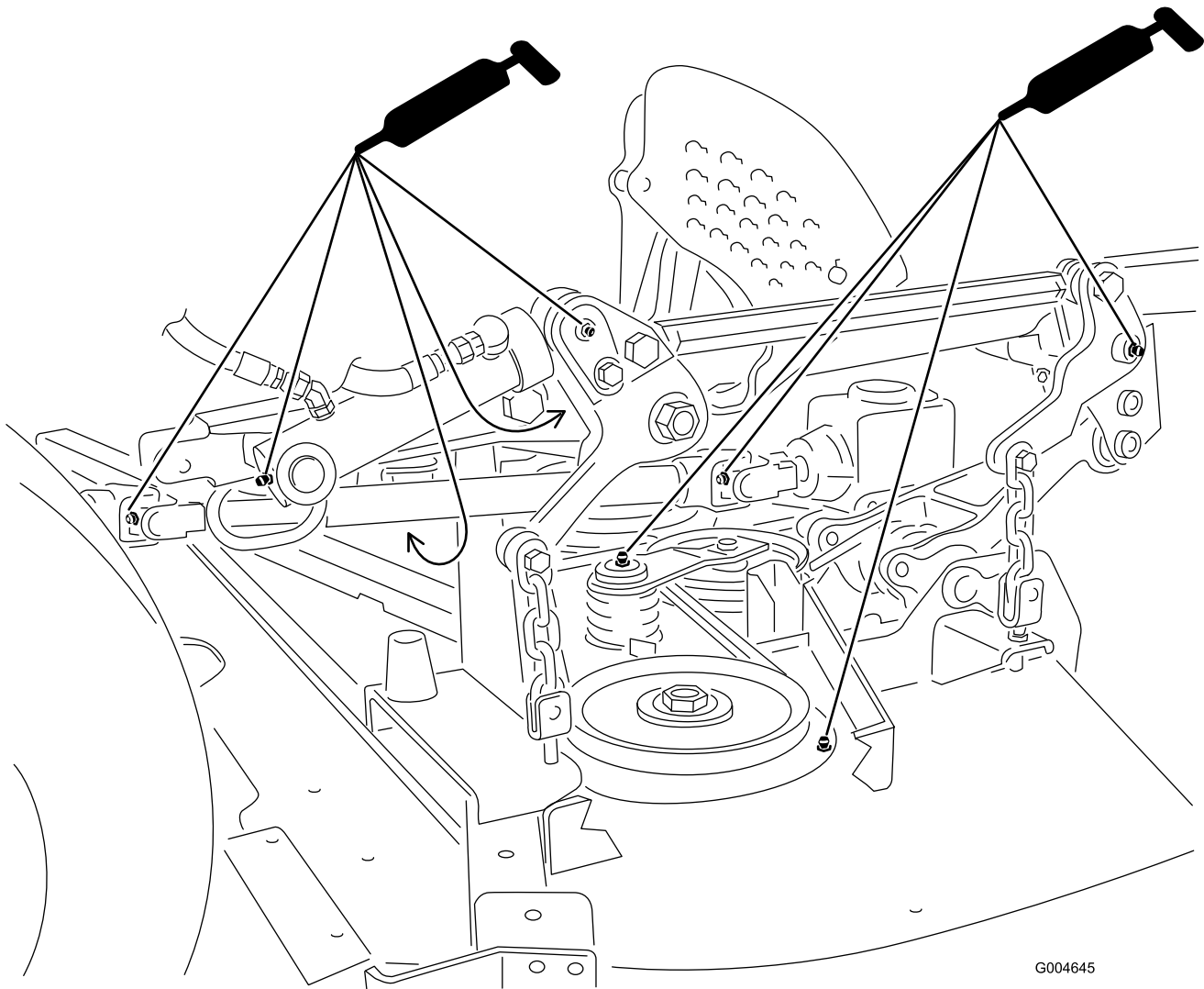

**Figure 53**  
Shown with mower deck installed

**Note:** To access the grease fittings for the rear-steering linkage, remove the storage compartment.

**Note:** Raise the machine off the floor to allow better grease migration through both the upper and lower king-pin bushings. You should see grease purging out of both the top and the bottom of the axle casting/bushing assembly areas of all 4 kingpin assemblies (Figure 54).

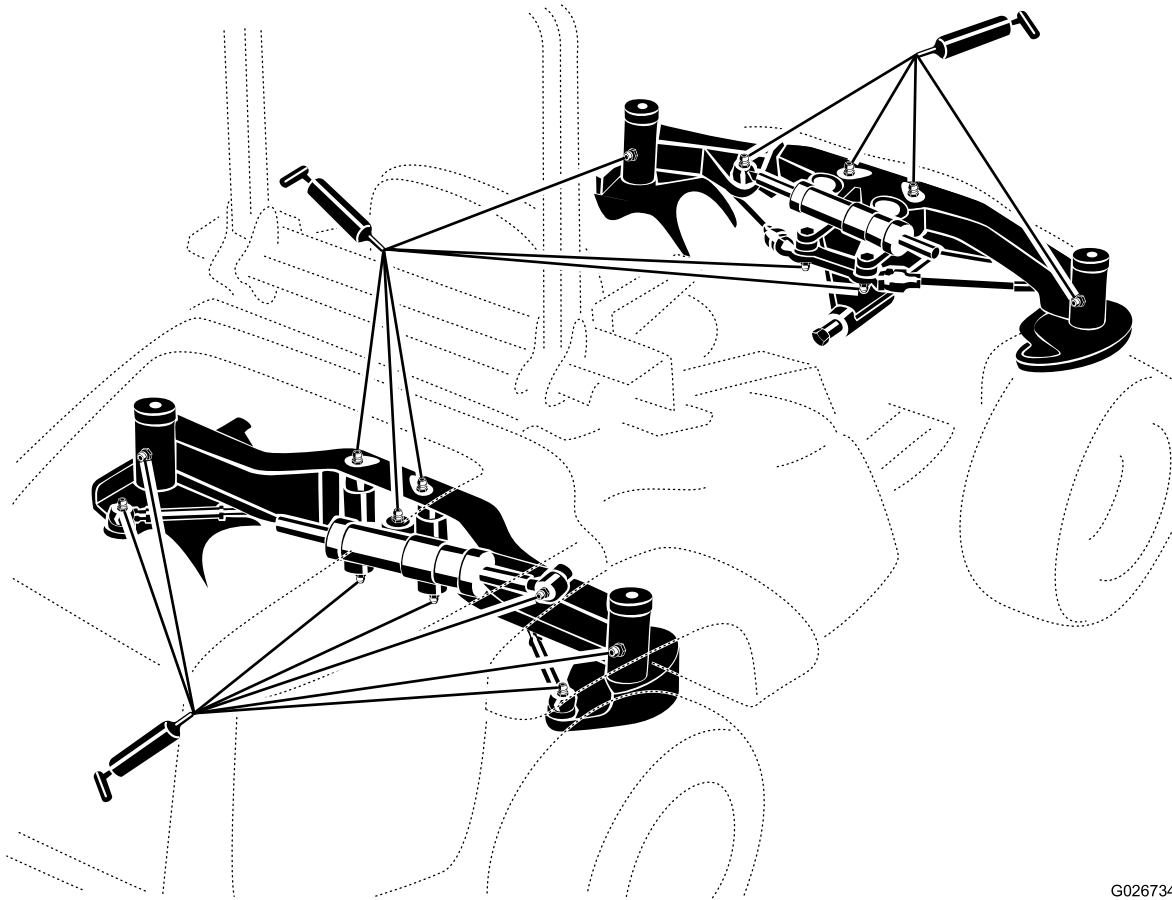

G026734

g026734

**Figure 54**

---

**Note:** The bearing life can be negatively affected by improper washing procedures. Do not wash the machine when it is still hot and avoid directing high-pressure or high-volume spray at the bearings or seals.

# Engine Maintenance

## Engine Safety

- Shut off the engine before checking the oil or adding oil to the crankcase.
- Do not change the governor speed or overspeed the engine.

## Servicing the Air Cleaner

**Service Interval:** Before each use or daily—Check the air-cleaner indicator.

Every 400 hours—Service the air cleaner (earlier if the air cleaner indicator shows red, and more frequently in extremely dirty or dusty conditions).

Check the air-cleaner body for damage, which could cause an air leak. Replace it if it is damaged. Check the whole intake system for leaks, damage, or loose hose clamps.

Service the air-cleaner filter only when the service indicator requires it (Figure 55). Changing the air filter before it is necessary only increases the chance of dirt entering the engine when you remove the filter.

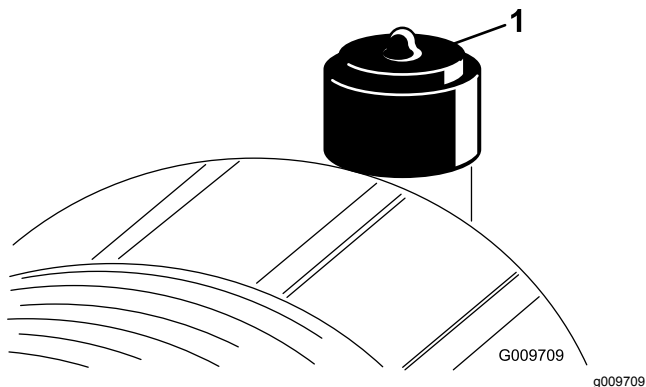

Figure 55

1. Air-cleaner indicator

**Important:** Be sure that the cover is seated correctly and seals with the air-cleaner body.

1. Replace the air cleaner (Figure 56).

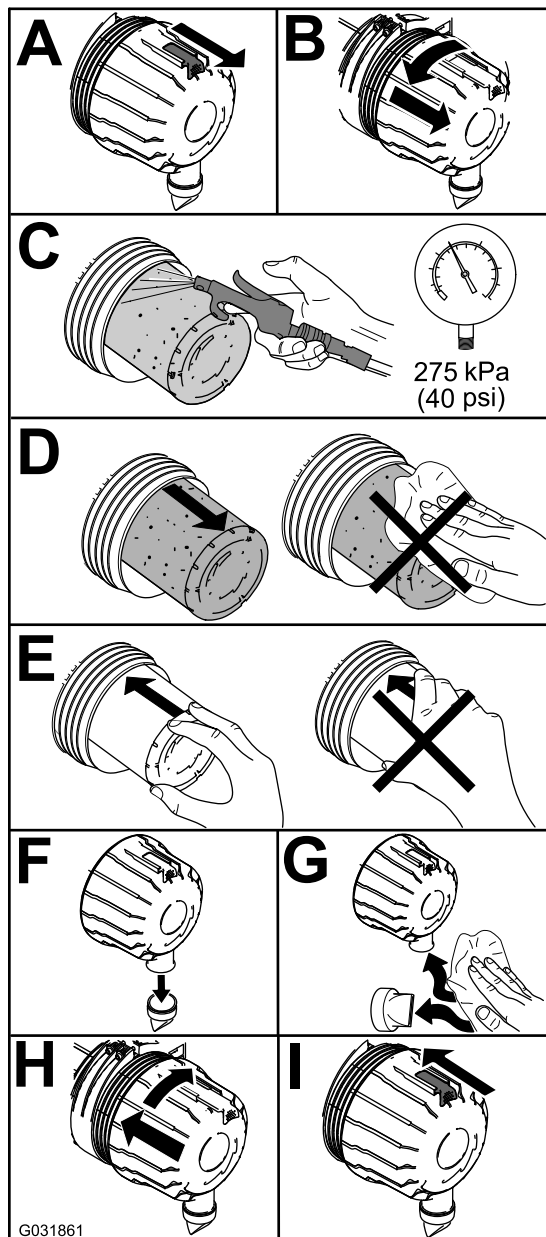
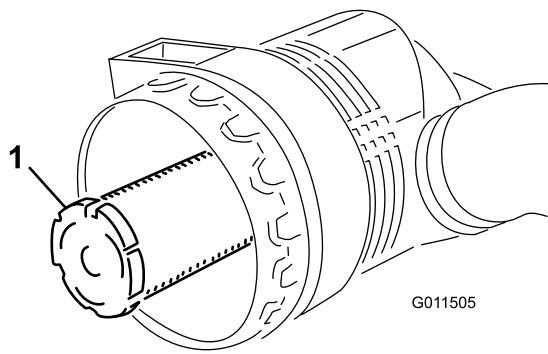

Figure 56

**Note:** Do not clean the used element due to the possibility of damage to the filter media.

**Important:** Never attempt to clean the safety filter (Figure 57). Replace the safety filter after every 3 primary filter services.





**Figure 57**

1. Air-cleaner safety filter

2. Reset the indicator (Figure 55) if it shows red.

## Servicing the Engine Oil

### Oil Specification

Use high-quality, low-ash engine oil that meets or exceeds the following specifications:

- API service category CJ-4 or higher
- ACEA service category E6
- JASO service category DH-2

**Important:** Using engine oil other than API CJ-4 or higher, ACEA E6, or JASO DH-2 may cause the diesel particulate filter to plug or cause engine damage.

Use the following engine oil viscosity grade:

- Preferred oil: SAE 15W-40 (above 0°F)
- Alternate oil: SAE 10W-30 or 5W-30 (all temperatures)

Toro Premium Engine Oil is available from your Authorized Toro Distributor in either 15W-40 or 10W-30 viscosity grades. See the parts catalog for part numbers.

### Checking the Engine-Oil Level

The engine is shipped with oil in the crankcase; however, the oil level must be checked before and after the engine is first started.

**Important:** Check the engine oil daily. If the engine-oil level is above the Full mark on the dipstick, the engine oil may be diluted with fuel; If the engine oil level is above the Full mark, change the engine oil.

The best time to check the engine oil is when the engine is cool before it has been started for the day. If it has already been run, allow the oil to drain back down to the sump for at least 10 minutes before

checking. If the oil level is at or below the Add mark on the dipstick, add oil to bring the oil level to the Full mark. **Do not overfill the engine with oil.**

**Important:** Keep the engine oil level between the upper and lower limits on the dipstick; the engine may fail if you run it with too much or too little oil.

1. Park the machine on a level surface, engage the parking brake, shut off the engine, remove the key from the key switch.
2. Remove the dipstick, wipe it clean, install the dipstick into the tube, and pull it out again. The oil level should be between the Full and Add marks (Figure 58).

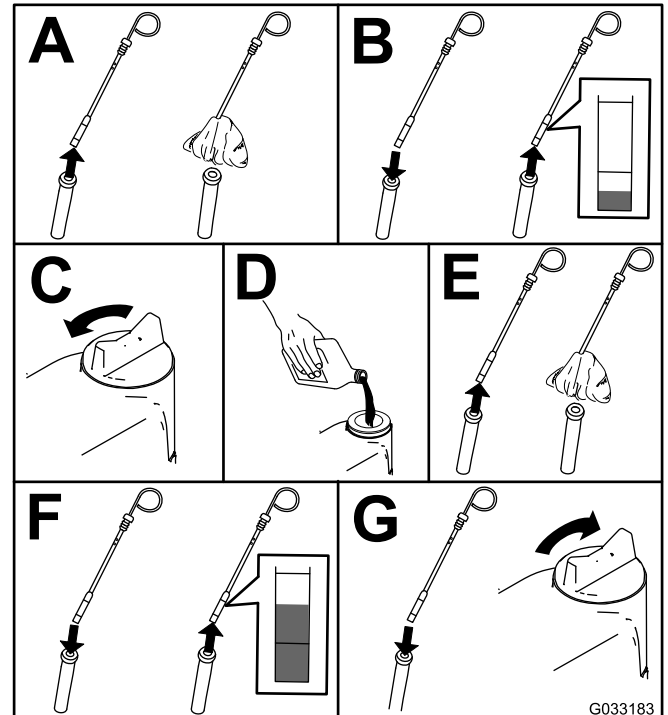

**Figure 58**

1. Dipstick
2. Oil-fill cap

### Crankcase Oil Capacity

5.2 L (5.5 US qt) with the filter.

### Changing the Engine Oil and Filter

**Service Interval:** Every 250 hours

1. Start the engine and let it run 5 minutes to allow the oil to warm up.
2. Park the machine on a level surface, engage the parking brake, shut off the engine, remove the key from the key switch.
3. Replace the engine oil and filter (Figure 59).

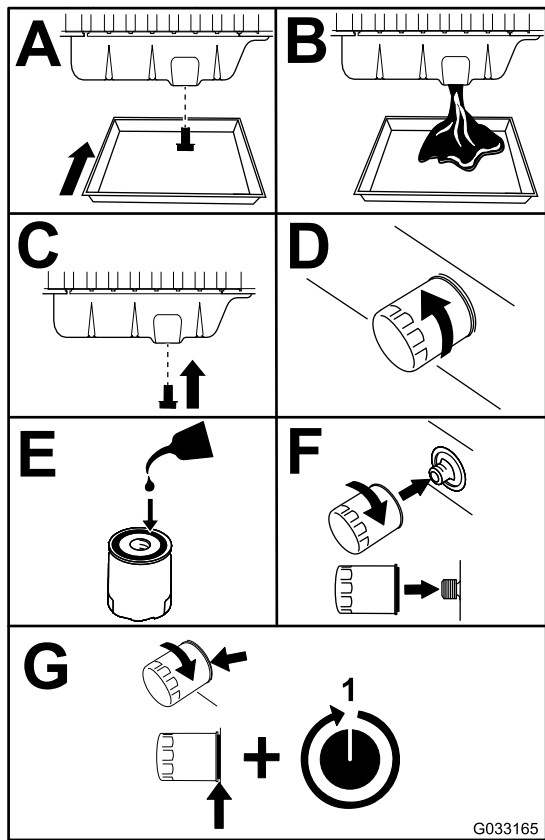
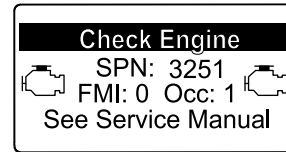

Figure 59

g033165

SPN 3720 FMI 16 in the InfoCenter (Figure 61) display in the InfoCenter, clean the soot filter using the steps that follow:



g214715



g213864



g213863

Figure 61

4. Add oil to the crankcase; refer to [Checking the Engine-Oil Level](#) (page 49).

## Servicing the Diesel-Oxidation Catalyst (DOC) and the Soot Filter

**Service Interval:** Every 6,000 hours or clean the soot filter if engine faults SPN 3720 FMI 16, SPN 3720 FMI 0, or SPN 3720 FMI 16 display in the InfoCenter.

- If advisory message ADVISORY 179 displays in the InfoCenter, the DPF is nearing the recommended point for servicing the diesel-oxidation catalyst and the soot filter.

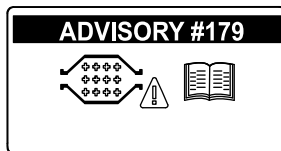

Figure 60

g213865

- If engine faults CHECK ENGINE SPN 3251 FMI 0, CHECK ENGINE SPN 3720 FMI 0, or CHECK ENGINE

# Fuel System Maintenance

Note: Refer to [Fuel Specification \(page 22\)](#) for the proper fuel recommendations.

## **⚠ DANGER**

Under certain conditions, diesel fuel and fuel vapors are highly flammable and explosive. A fire or explosion from fuel can burn you and others and can cause property damage.

- Use a funnel and fill the fuel tank outdoors, in an open area, when the engine is off and is cold. Wipe up any fuel that spills.
- Do not fill the fuel tank completely full. Add fuel to the fuel tank until the level is to the bottom of the filler neck.
- Never smoke when handling fuel and stay away from an open flame or where a spark may ignite fuel fumes.
- Store fuel in a clean, safety-approved container and keep the cap in place.

## Servicing the Water Separator

Service Interval: Before each use or daily  
Every 400 hours

Service the water separator as shown in [Figure 62](#).

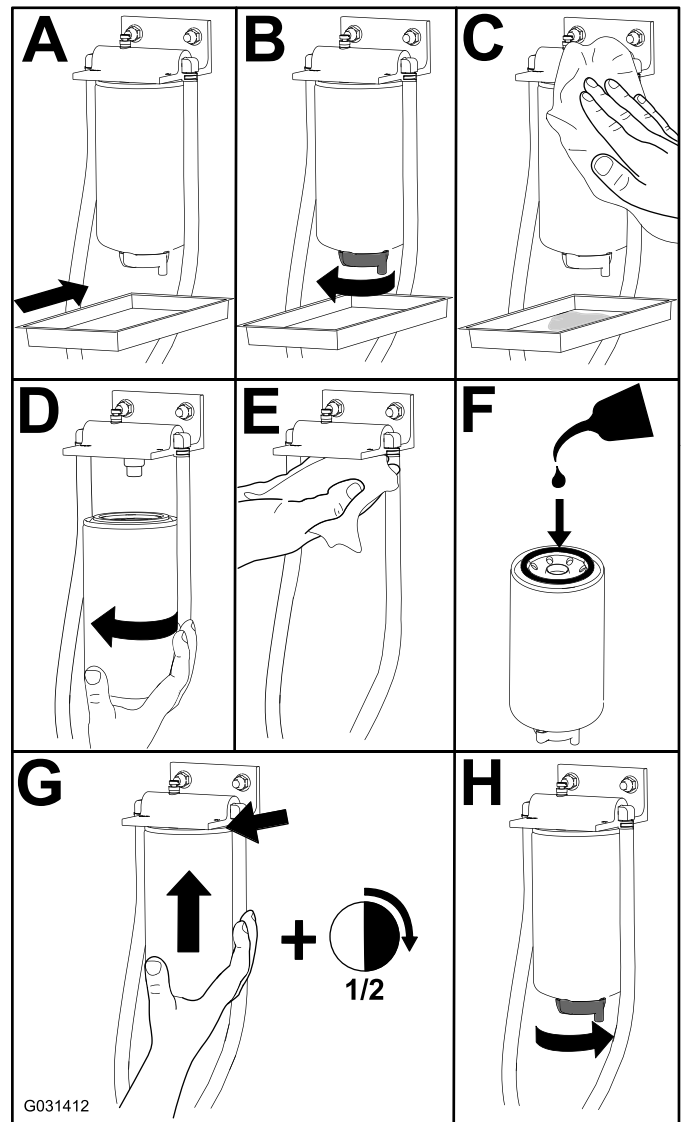

Figure 62

# Servicing the Engine Fuel Filter

Service Interval: Every 400 hours

1. Clean the area around the filter head (Figure 63).

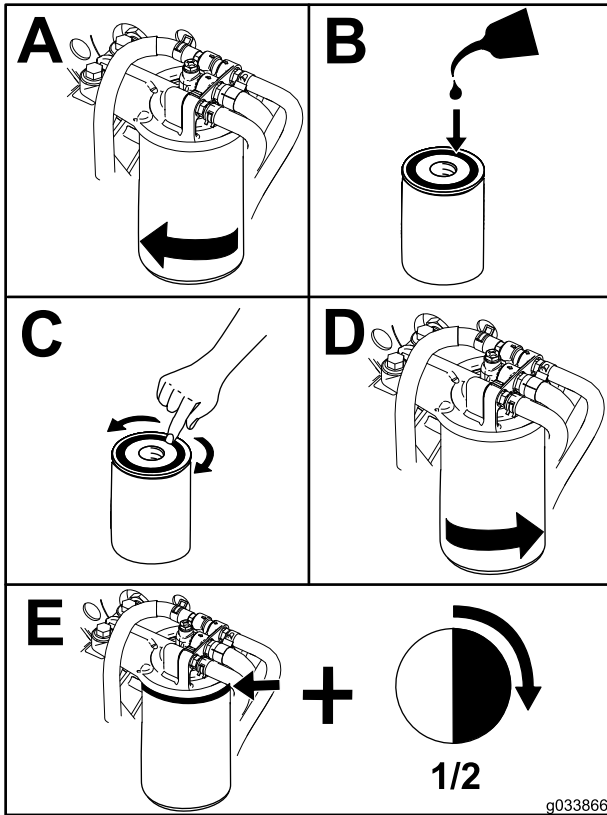

Figure 63

2. Start the engine and check for fuel leaks around the filter head.

## Checking the Fuel Lines and Connections

Service Interval: Every 400 hours

Inspect the fuel lines and connections for deterioration, damage, or loose connections.

## Cleaning the Fuel Pick-Up Tube Screen

The fuel pick-up tube, located inside the fuel tank, is equipped with a screen to help prevent debris from entering the fuel system. Remove the fuel pick-up tube and clean the screen as required.

# Electrical System Maintenance

**Important:** Whenever working with the electrical system, always disconnect the battery cables, negative (-) cable first, to prevent possible wiring damage from short-outs.

## Electrical System Safety

- Disconnect the battery before repairing the machine. Disconnect the negative terminal first and the positive last. Connect the positive terminal first and the negative last.
- Charge the battery in an open, well-ventilated area, away from sparks and flames. Unplug the charger before connecting or disconnecting the battery. Wear protective clothing and use insulated tools.

### WARNING

**CALIFORNIA**  
Proposition 65 Warning

Battery posts, terminals, and related accessories contain lead and lead compounds, chemicals known to the State of California to cause cancer and reproductive harm. Wash hands after handling.

## Checking the Fuses

If the machine stops or has other electrical-system issues, check the fuses. Grasp each fuse in turn and remove them 1 at a time, checking to see if any are blown. If you need to replace a fuse, always use the **same type and amperage rated fuse** as the 1 you are replacing; **otherwise, you could damage the electrical system** (refer to the decal next to the fuses for a diagram of each fuse and its amperage).

Tilt the seat forward, and pull the panel off to access the fuses (Figure 64).

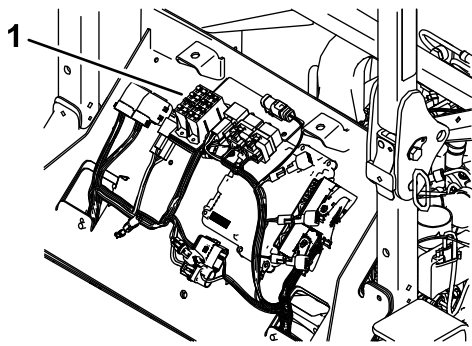

Figure 64

g198812

1. Fuse block

The fuse block for attachments are located under the seat (Figure 65).

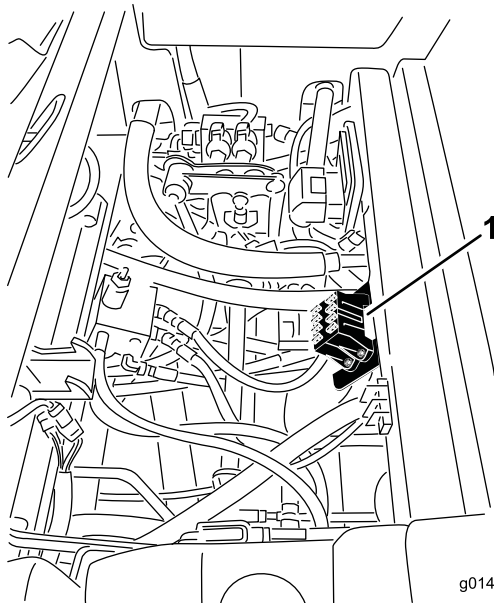

Figure 65

g014186

g014186

1. Location of the fuse block

The cab fuses are located in the fuse box on the cab headliner (Figure 66).

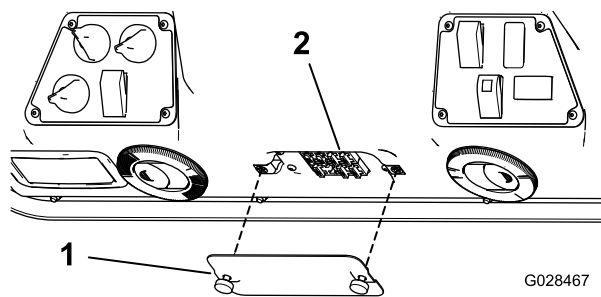

Figure 66

G028467

g028467

1. Cover
2. Fuses

## Servicing the Battery

**Service Interval:** Every 50 hours

Keep the top of the battery clean. If you store the machine in a location where temperatures are extremely high, the battery will run down more rapidly than if the machine is stored in a location where temperatures are cool.

Keep the top of the battery clean by washing it periodically with a brush dipped in ammonia or baking-soda solution. Flush the top surface with water after cleaning it. Do not remove the fill caps while cleaning the battery.

The battery cables must be tight on the terminals to provide good electrical contact.

If corrosion occurs at the terminals, disconnect the cables, negative (-) cable first, and scrape the clamps and terminals separately. Connect the cables, positive (+) cable first, and coat the terminals with petroleum jelly.

### ⚠ WARNING

**Battery terminals or metal tools could short against metal machine components, causing sparks. Sparks can cause the battery gasses to explode, resulting in personal injury.**

- When removing or installing the battery, do not allow the battery terminals to touch any metal parts of the machine.
- Do not allow metal tools to short between the battery terminals and metal parts of the machine.

### ⚠ WARNING

**Incorrect battery cable routing could damage the machine and cables causing sparks. Sparks can cause the battery gasses to explode, resulting in personal injury.**

- Always disconnect the negative (black) battery cable before disconnecting the positive (red) cable.
- Always connect the positive (red) battery cable before connecting the negative (black) cable.

## Storing the Battery

If the machine will be stored more than 30 days, remove the battery and charge it fully. Either store it on a shelf or on the machine. Leave the cables disconnected if it is stored on the machine. Store the battery in a cool atmosphere to avoid quick

deterioration of the charge in the battery. To prevent the battery from freezing, make sure that it is fully charged. The specific gravity of a fully charged battery is 1.265 to 1.299.

## Drive System Maintenance

### Checking the Tire Pressure

**Service Interval:** Every 50 hours

Maintain the air pressure in the front and rear tires. The correct air pressure is 172 kPa (25 psi) in the rear tires and 103 kPa (15 psi) in the front tires. If a cab is installed on the machine, the front and rear tires should be inflated to 172 kPa (25 psi). Uneven tire pressure can cause an uneven cut. Check the tires when they are cold to get the most accurate pressure reading.

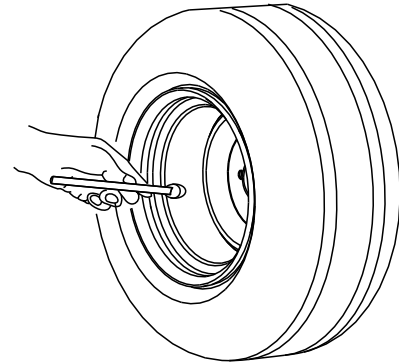

G001055

Figure 67

g001055

---

### Correcting Steering Misalignment

1. Press the steering selector switch to the rearward 4-wheel-steer position (Figure 68).

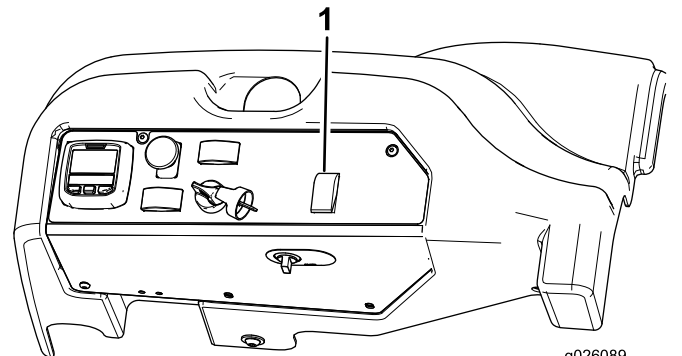

g026089

g026089

Figure 68

1. Steering-selector switch

2. On a paved or dirt surface, turn the steering wheel to the left or right and continue turning until all 4 wheels have stopped turning. Automatic

synchronization of wheel alignment should occur.

**Important:** Doing this procedure on turf can result in turf directly under each of the turning tires.

# Cooling System Maintenance

## Cooling System Safety

- Swallowing engine coolant can cause poisoning; keep out of reach from children and pets.
- Discharge of hot, pressurized coolant or touching a hot radiator and surrounding parts can cause severe burns.
  - Always allow the engine to cool at least 15 minutes before removing the radiator cap.
  - Use a rag when opening the radiator cap, and open the cap slowly to allow steam to escape.

## Checking the Cooling System

**Service Interval:** Before each use or daily

### **⚠ DANGER**

The rotating fan and drive belt can cause personal injury.

- Do not operate the machine without the covers in place.
- Keep your fingers, hands and clothing clear of rotating fan and drive belt.
- Shut off the engine and remove the key from the key switch before performing maintenance.

The cooling system is filled with a 50/50 solution of water and permanent ethylene glycol anti freeze. Check the level of the coolant in the expansion tank at the beginning of each day before starting the engine. The capacity of the cooling system is 7.5 L (6 US qt).

1. Check the level of the coolant in the expansion tank (Figure 69). The coolant level should be between the marks on the side of the tank.
2. If coolant level is low, remove the expansion tank cap and replenish the system. **Do not overfill.**

3. Install the expansion-tank cap.

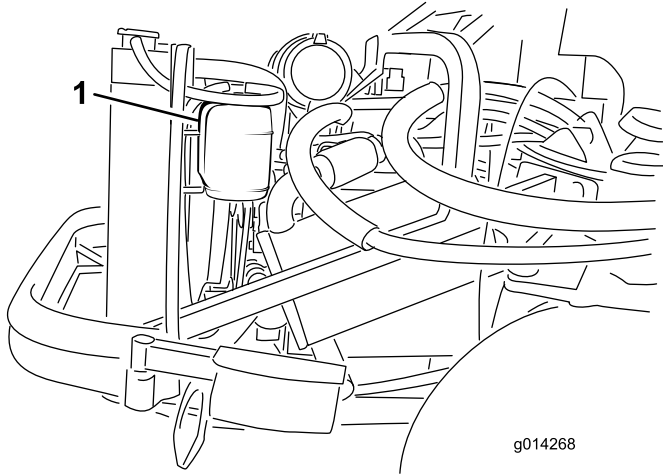

**Figure 69**

1. Expansion tank

compressed air (**do not use water**). Repeat this step from the front of the radiator, again from the fan side.

4. After you have thoroughly cleaned the radiator, remove any debris from the channel at the radiator base and around the frame.
5. Clean the engine compartment and the brake linkage.
6. Close the clean-out cover and secure the flange nut.
7. Close the hood.

---

## Cleaning the Radiator

**Service Interval:** Before each use or daily Clean the radiator more frequently in extremely dusty and dirty conditions.

Keep the radiator clean to prevent the engine from overheating.

**Note:** If the attachment or engine shuts off due to overheating, first check the radiator for an excessive buildup of debris.

1. Open the hood and secure the prop rod.
2. Loosen the flange nut securing the clean-out cover to the underside of the rear frame ([Figure 70](#)). Rotate the cover to the side to expose the clean-out hole in the frame.

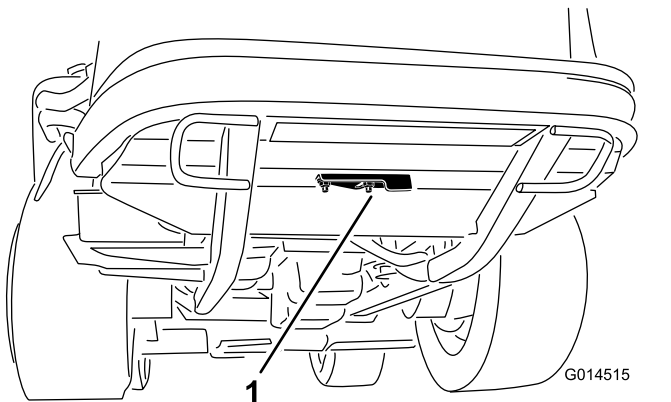

**Figure 70**

1. Clean-out cover

3. Working from the fan side of the radiator, blow out debris with low-pressure (50 psi)



# Brake Maintenance

## Adjusting the Service Brakes

Adjust the service brakes when there is more than 25 mm (1 inch) of free travel of the brake pedal, or when the brakes do not work effectively. Free travel is the distance that the brake pedal moves before you feel braking resistance.

**Note:** Use the wheel-motor backlash to rock the drums back and forth to ensure that the drums are free prior to and after adjustment.

1. To reduce free travel of the brake pedals, tighten the brakes by loosening the front nut on the threaded end of the brake cable (Figure 71).

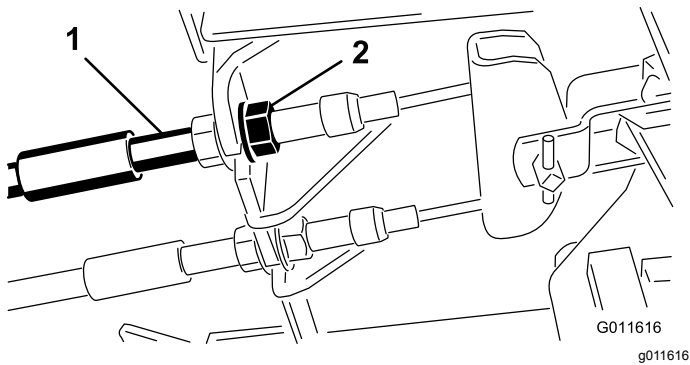

Figure 71

1. Brake cables
2. Front nuts

2. Tighten the rear nut to move the cable backward until brake pedals have 1.27 to 1.9 cm (1/2 to 3/4 inch) of free travel before the wheels lock up.
3. Tighten the front nuts, ensuring that both cables actuate the brakes simultaneously.

## Adjusting the Parking Brake

If the parking brake fails to engage, an adjustment to the brake pawl is required.

1. Loosen the 2 screws securing the parking-brake pawl to the frame (Figure 72).

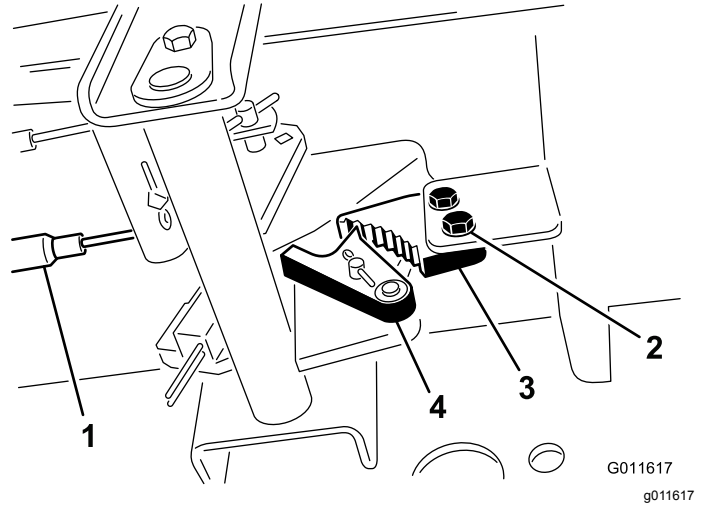

Figure 72

1. Brake cables
2. Screws (2)
3. Parking-brake pawl
4. Brake detent

2. Press the parking-brake pedal forward until the brake detent completely engages on the brake pawl (Figure 72).
3. Tighten the 2 screws to lock the adjustment.
4. Press the brake pedal to release the parking brake.
5. Check the adjustment and adjust it again as required.

# Belt Maintenance

## Checking the Alternator Belt

**Service Interval:** After the first 10 hours

Every 100 hours

Check the condition and tension of the belt (Figure 73) after every 100 operating hours.

1. Ensure that the proper tension allows 10 mm (3/8 inch) deflection when a force of 4.4 kg (10 lb) is applied on the belt midway between the pulleys.
2. If the deflection is not 10 mm (3/8 inch), loosen the alternator mounting bolts (Figure 73). Increase or decrease the tension of the alternator belt and tighten the bolts. Check the deflection of the belt again to ensure that the tension is correct.

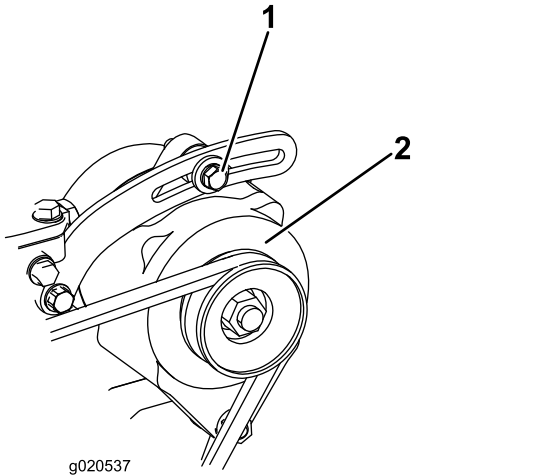

Figure 73

1. Mounting bolt
2. Alternator

# Controls System Maintenance

## Adjusting the Traction Drive for Neutral

**Note:** If the machine has recently had the hydraulic fluid changed or the traction motors or hoses replaced, work out any air trapped in the system prior to performing this procedure. To do this, operate the machine in forward and reverse for a few minutes and then replenish the oil as required.

**Note:** When positioned on a level surface, the machine must not creep when you release the traction pedal.

1. Park the machine on a level surface, engage the parking brake, lower the cutting unit to the floor, and shut off the engine.
2. Jack up the rear of the machine until the rear tires are off the shop floor. Support the machine with jack stands to prevent it from falling.

**Note:** On 4-wheel-drive models, the front tires must also be off the shop floor and supported by jack stands.

### ⚠ WARNING

The engine must be running so that you can perform this adjustment. This could cause personal injury.

Keep your hands, feet, face, and other body parts away from any hot parts of the engine and any rotating parts.

3. Start the engine, set the throttle to the SLOW position, and observe which direction the rear tires rotate.

**Important:** Make sure that the traction pedal is in the NEUTRAL position.

- If the left rear tire is rotating, loosen the jam nuts on the left side transmission control rod (Figure 74).

**Note:** The forward end of the control rod has a left-hand thread. The rear end of the rod, which is connected to the transmission, has a right-hand thread.

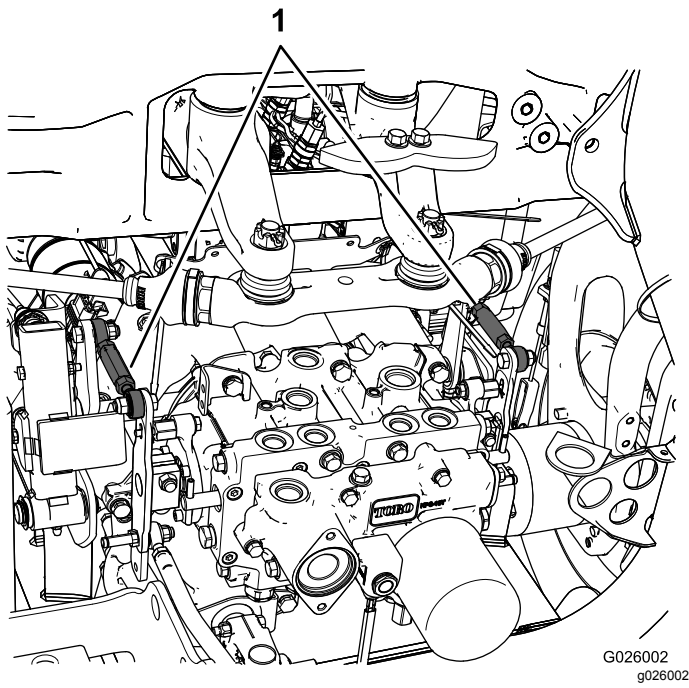

**Figure 74**

1. Transmission control rods

- If the left rear tire is rotating in reverse, lengthen the rod by slowly turning the rod counterclockwise (as viewed from the front) until the left rear tire stops rotating or has minimal rotation in reverse.
  - If the left rear tire is rotating forward, shorten the rod by slowly turning the rod clockwise (as viewed from the front) until the left rear tire stops rotating.
4. Move the throttle to the FAST position. Make sure that the wheel remains stopped or has minimal rotation in reverse. Adjust it as required.
  5. Tighten the jam nuts.
  6. Repeat the procedure for the right rear tire, if required, by using the right-side transmission control rod.
  7. Shut off the engine, remove the jack stands, and lower the machine to the shop floor.
  8. Test drive the machine to make sure that it does not creep.

## Adjusting the Maximum Ground Speed

1. Park the machine on a level surface, disengage the PTO, release the traction pedal to the NEUTRAL position, and engage the parking brake.
2. Move the throttle lever to the SLOW position, shut off the engine, remove the key from the key switch, and wait for all moving parts to stop before leaving the operating position.
3. Loosen the jam nut on the stop bolt for the traction pedal (Figure 75).

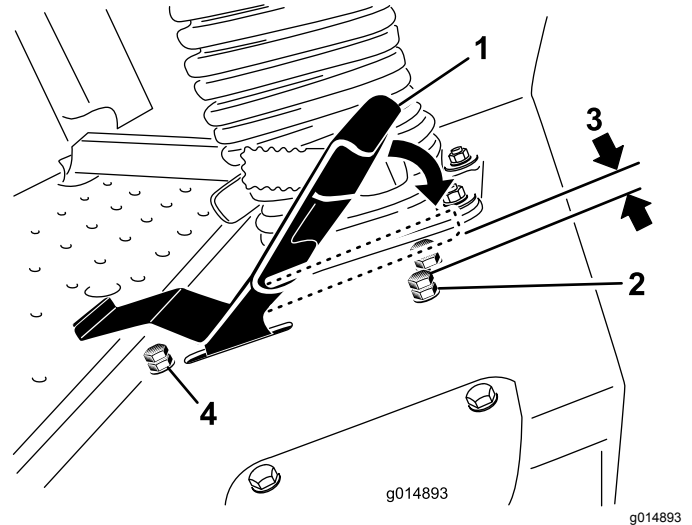

**Figure 75**

- |                                     |                                     |
|-------------------------------------|-------------------------------------|
| 1. Traction pedal                   | 3. 1.5 mm (0.060 inch)              |
| 2. Stop bolt with jam nut (forward) | 4. Stop bolt with jam nut (reverse) |

4. Adjust the stop bolt all the way in (away from the traction pedal).
5. Using your hand, push the traction pedal all the way forward, with light pressure, until it stops and hold it there.
 

**Note:** Maintain only light pressure on the pedal when pushing it to the full forward position.
6. With the seat in the raised position, verify that you are not over loading the linkage by making sure the transmission does not move when you press the pedal to the stop.
7. Adjust the stop bolt out (toward the traction pedal) until there is a gap of 1.5 mm (0.060 inch) between the head of the stop bolt and the bottom of the traction pedal.
8. Tighten the jam nut to secure the stop bolt in place.
9. To change the reverse speed, you can adjust the reverse stop bolt. To increase the reverse

speed, adjust the stop bolt in; to decrease the reverse speed, adjust the stop bolt out.

# Hydraulic System Maintenance

## Hydraulic System Safety

- Ensure that all hydraulic-fluid hoses and lines are in good condition and all hydraulic connections and fittings are tight before applying pressure to the hydraulic system.
- Keep your body and hands away from pinhole leaks or nozzles that eject high-pressure hydraulic fluid.
- Use cardboard or paper to find hydraulic leaks.
- Safely relieve all pressure in the hydraulic system before performing any work on the hydraulic system.
- Seek immediate medical attention if fluid is injected into skin. Injected fluid must be surgically removed within a few hours by a doctor.

## Checking the Hydraulic System

**Service Interval:** Before each use or daily

The reservoir is filled at the factory with approximately 17 L (18 US qt) of high-quality tractor transmission/hydraulic fluid. The recommended replacement fluid is as follows:

**Toro Premium Transmission/Hydraulic Tractor Fluid** (Available in 19 L (5 gallon) pails or 208 L (55 gallon) drums. See the *Parts Catalog* or your Toro Distributor for part numbers).

Alternate fluids: If the Toro fluid is not available, Mobil® 424 hydraulic fluid may be used.

**Note:** Toro will not assume responsibility for damage caused by improper substitutions.

**Note:** Many hydraulic fluids are almost colorless, making it difficult to spot leaks. A red dye additive for the hydraulic system oil is available in 20 ml (2/3 fl oz) bottles. One bottle is sufficient for 15 to 22 L (4 to 6 US gallons) of hydraulic fluid. Order Part No. 44-2500 from your authorized Toro distributor.

1. Park the machine on a level surface, release the traction pedal to the NEUTRAL position, and start the engine.
2. Run the engine at the lowest possible speed to purge the system of air.

**Important:** Do not engage the PTO.

3. Raise the deck to extend the lift cylinders, shut off the engine, and remove the key from the key switch.
4. Remove the hydraulic-filler cap (Figure 76) from the filler neck.
5. Remove the dipstick and wipe it with a clean rag (Figure 76).
6. Screw the dipstick all the way into the filler neck; then remove it, and check the level of the fluid (Figure 76).

If the level is not within the notched area of the dipstick, add enough high-quality hydraulic fluid to raise the level to within the notched area. **Do not overfill the hydraulic system.**

7. Replace the dipstick and thread the fill cap finger-tight onto the filler neck.
8. Check all hoses and fittings for leaks.

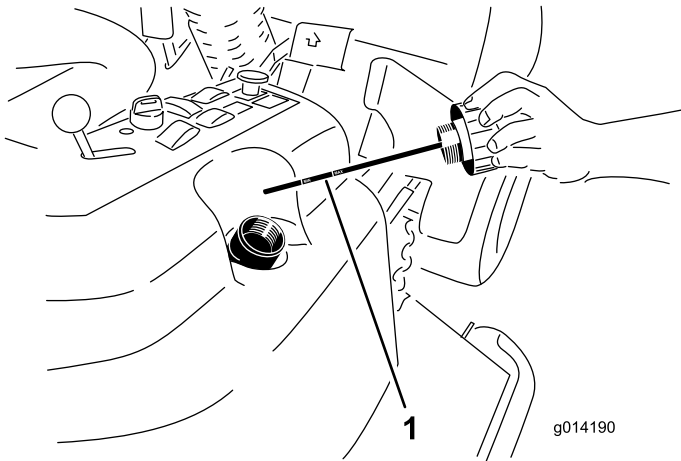

Figure 76

1. Dipstick

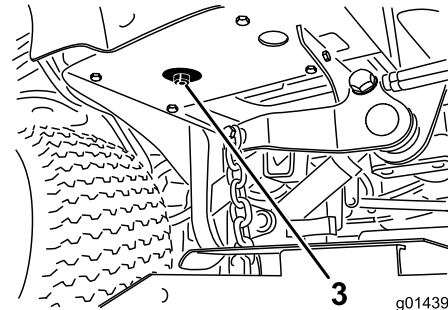
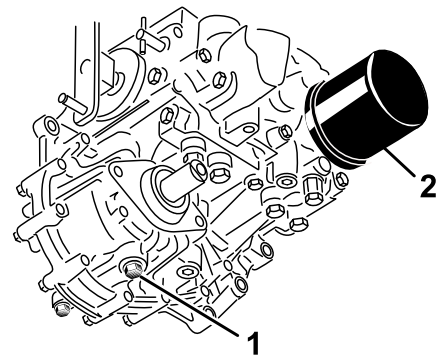

Figure 77

1. Transmission-case drain plug
2. Filter
3. Hydraulic-reservoir drain plug

4. Clean the area around the hydraulic-fluid filter and remove the filter (Figure 77).
5. Immediately install a new hydraulic-fluid filter.
6. Install the drain plugs in the hydraulic reservoir and the transmission case.
7. Fill the reservoir to the proper level; refer to [Checking the Hydraulic System \(page 60\)](#).
8. Start the engine and check for fluid leaks. Allow the engine to run for about 5 minutes, then shut it off.
9. After 2 minutes, check the level of the hydraulic fluid; refer to [Checking the Hydraulic System \(page 60\)](#).

## Changing the Hydraulic Fluid And Filter

**Service Interval:** After the first 200 hours

Every 800 hours

1. Disengage the PTO, release the traction pedal to the NEUTRAL position, and engage the parking brake.
2. Move the throttle lever to the SLOW position, shut off the engine, remove the key from the key switch, and wait for all moving parts to stop before leaving the operating position.
3. Place a large pan under the hydraulic reservoir and transmission case and remove the plugs, draining all of the hydraulic fluid (Figure 77).

# Cab Maintenance

## Filling the Washer-Fluid Bottle

1. Perform the pre-maintenance procedure; refer to [Preparing the Machine for Maintenance](#) (page 45).
2. Open the hood and locate the washer-fluid bottle (Figure 78).

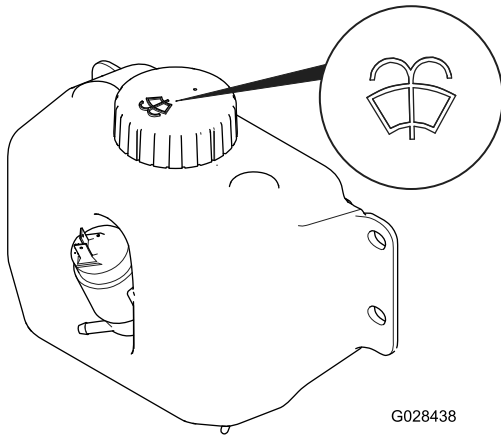

**Figure 78**

Washer-Fluid Bottle with Washer-Fluid Symbol

3. Fill the bottle with washer fluid as needed.
4. Close the hood.

## Cleaning the Cab Air Filters

**Service Interval:** Every 250 hours Replace the cab air filters if they are torn or excessively dirty.

1. Remove the screws and grates from over both the in-cab and rear cab air filters ([Figure 79](#) and [Figure 80](#)).

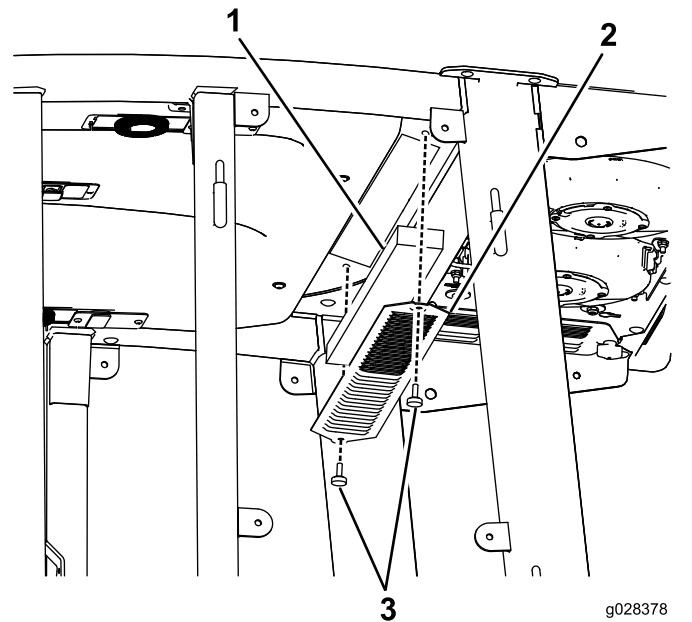

**Figure 79**

1. Filter
2. Grate
3. Screw

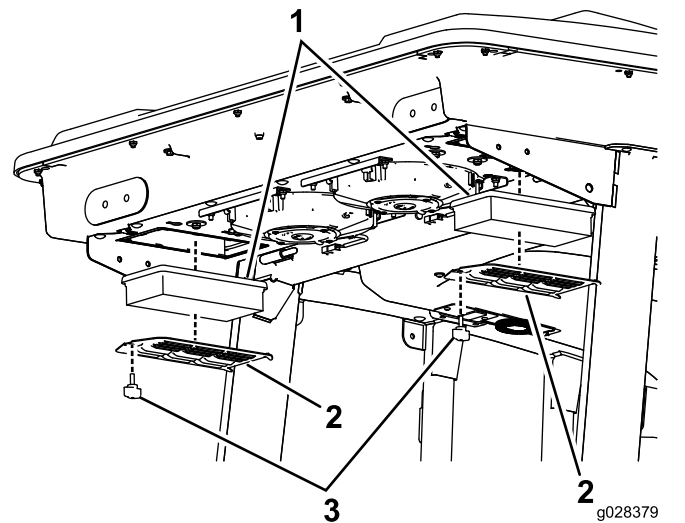

**Figure 80**

1. Filter
2. Grate
3. Screw

2. Clean the filters by blowing clean, oil-free, compressed air through them.

**Important:** If either filter has a hole, tear, or other damage, replace it.

3. Install the filters and grate, securing them with the thumbscrews.

# Cleaning the Air-Conditioning Coil

**Service Interval:** Every 50 hours Clean the air-conditioning coil more frequently in extremely dusty or dirty conditions.

1. Perform the pre-maintenance procedure; refer to [Preparing the Machine for Maintenance \(page 45\)](#).
2. Lift the 4 tabs on the air-conditioning screen ([Figure 81](#)) and remove the screen from the top of the cab.

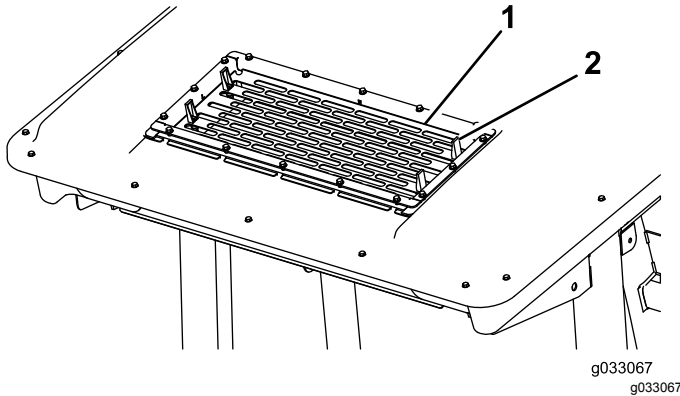

**Figure 81**

1. Screen
2. Tab (4)

3. Disconnect the plug and cord for the fans from the outlet ([Figure 82](#)).

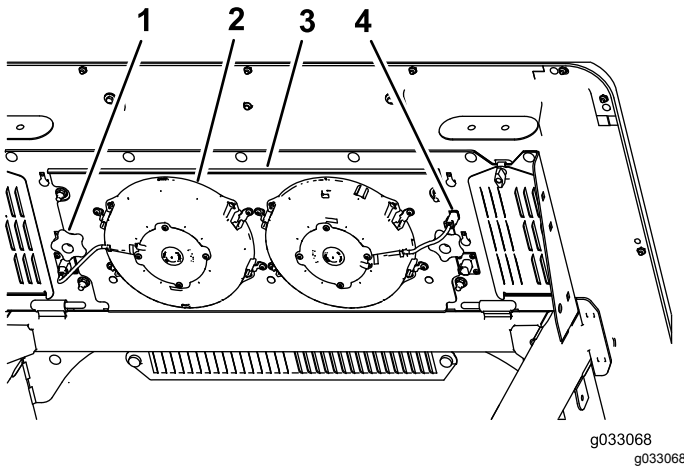

**Figure 82**

1. Knob (2)
2. Fan (2)
3. Fan panel
4. Plug and cord (2)

4. Remove the 2 knobs that secure the fan-panel assembly and fans to the underside of the cab top ([Figure 82](#)) and remove the assembly.

5. Clean the screen, air-conditioning duct, fans, and fan panel using low-pressure air no greater than 276 kPa (40 psi).

**Important:** Do not use water to clean the condenser because moisture on the components attracts dirt and dust, which make the components more difficult to clean.

6. Install the fan-panel assembly and fans to the underside of the cab top with the 2 knobs that you loosened and removed in step 4.
7. Connect the cord for the fans that you disconnected in step 3 into the outlet.
8. Install the air-conditioning screen in the opening in the top of the cab and secure it by closing the 4 tabs on the screen.

# Cleaning

## Cleaning the Cab

**Important:** Use care around the cab seals and lights (Figure 83). If you are using a pressure washer, keep the washer wand at least 0.6 m (2 ft) away from the machine. Do not use the pressure washer directly on the cab seals and lights or under the rear overhang.

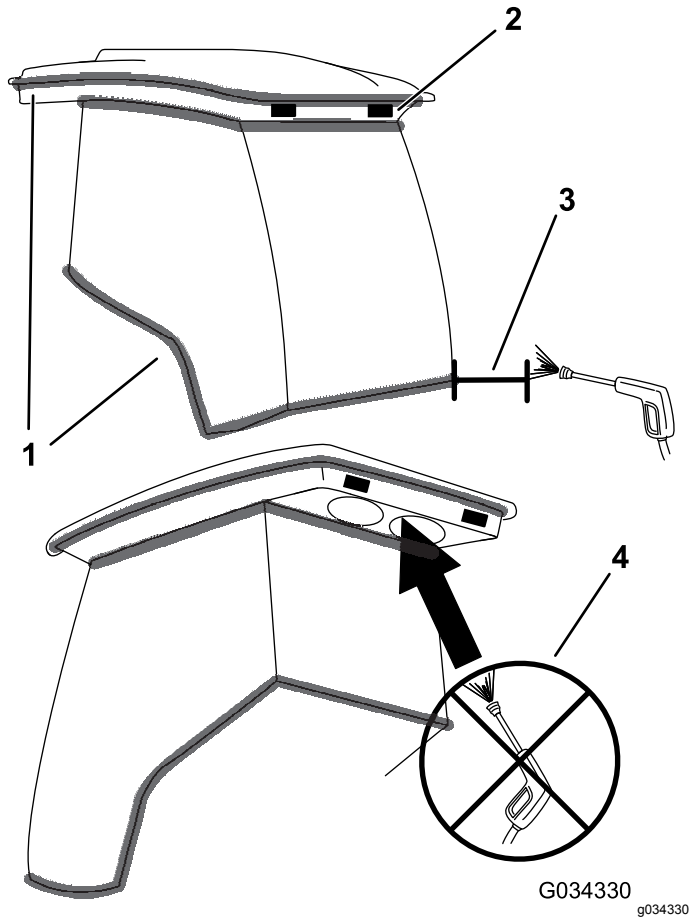

Figure 83

1. Seal
2. Light
3. Keep wand 0.6 m (2 ft) away.
4. Do not pressure-wash under the rear overhang.

## Disposing of Waste

Engine oil, batteries, hydraulic fluid, and engine coolant are pollutants to the environment. Dispose of these according to your state and local regulations.

# Storage

## Preparing the Engine

1. Drain the engine oil from the oil pan and install the drain plug.
2. Change the engine oil and filter; refer to [Changing the Engine Oil and Filter \(page 49\)](#).
3. Fill the engine with the designated quantity of engine oil; refer to [Checking the Engine-Oil Level \(page 49\)](#).
4. Start the engine and run it at idle speed for 2 minutes.
5. Drain the fuel from the fuel tank, fuel lines, pump, filter, and separator. Flush the fuel tank with clean diesel fuel and connect all fuel lines.
6. Thoroughly clean and service the air-cleaner assembly.
7. Seal the air-cleaner inlet and the exhaust outlet with weatherproof masking tape.
8. Check the oil-filler cap and fuel-tank cap to ensure that they are securely in place.

## Preparing the Machine

1. Thoroughly clean the machine, the deck, and the engine, paying special attention to the following areas:
  - Radiator and radiator screen
  - Counterbalance springs
  - PTO-shaft assembly
  - All grease fittings and pivot points
  - Inside of the control box (Remove the control panel for access.)
  - Beneath the seat plate and the top of the transmission
2. Check and adjust the tire pressure; refer to [Checking the Tire Pressure \(page 54\)](#).
3. Check all fasteners for looseness and tighten them as necessary.
4. Grease or oil all grease fittings, pivot points, and transmission bypass-valve pins. Wipe off any excess lubricant.
5. Lightly sand and use touch-up paint on painted areas that are scratched, chipped, or rusted. Repair any dents in the metal body.
6. Service the battery and cables as follows:
  - A. Remove the battery terminals from the battery posts.
  - B. Clean the battery, terminals, and posts with a wire brush and baking-soda solution.



- C. Coat the cable terminals and battery posts with Grafo 112X skin-over grease (Toro Part No. 505-47) or petroleum jelly to prevent corrosion.
- D. Slowly charge the battery for 24 hours every 60 days to prevent lead sulfation of the battery.

# Notes:

# Notes:



# The Toro Warranty

## A Two-Year Limited Warranty

### Conditions and Products Covered

The Toro Company and its affiliate, Toro Warranty Company, pursuant to an agreement between them, jointly warrant your Toro Commercial product ("Product") to be free from defects in materials or workmanship for two years or 1500 operational hours\*, whichever occurs first. This warranty is applicable to all products with the exception of Aerators (refer to separate warranty statements for these products). Where a warrantable condition exists, we will repair the Product at no cost to you including diagnostics, labor, parts, and transportation. This warranty begins on the date the Product is delivered to the original retail purchaser.

\* Product equipped with an hour meter.

### Instructions for Obtaining Warranty Service

You are responsible for notifying the Commercial Products Distributor or Authorized Commercial Products Dealer from whom you purchased the Product as soon as you believe a warrantable condition exists. If you need help locating a Commercial Products Distributor or Authorized Dealer, or if you have questions regarding your warranty rights or responsibilities, you may contact us at:

Toro Commercial Products Service Department  
Toro Warranty Company  
8111 Lyndale Avenue South  
Bloomington, MN 55420-1196  
952-888-8801 or 800-952-2740  
E-mail: commercial.warranty@toro.com

### Owner Responsibilities

As the Product owner, you are responsible for required maintenance and adjustments stated in your *Operator's Manual*. Failure to perform required maintenance and adjustments can be grounds for disallowing a warranty claim.

### Items and Conditions Not Covered

Not all product failures or malfunctions that occur during the warranty period are defects in materials or workmanship. This warranty does not cover the following:

- Product failures which result from the use of non-Toro replacement parts, or from installation and use of add-on, or modified non-Toro branded accessories and products. A separate warranty may be provided by the manufacturer of these items.
- Product failures which result from failure to perform recommended maintenance and/or adjustments. Failure to properly maintain your Toro product per the Recommended Maintenance listed in the *Operator's Manual* can result in claims for warranty being denied.
- Product failures which result from operating the Product in an abusive, negligent, or reckless manner.
- Parts subject to consumption through use unless found to be defective. Examples of parts which are consumed, or used up, during normal Product operation include, but are not limited to, brake pads and linings, clutch linings, blades, reels, rollers and bearings (sealed or greasable), bed knives, spark plugs, castor wheels and bearings, tires, filters, belts, and certain sprayer components such as diaphragms, nozzles, and check valves, etc.
- Failures caused by outside influence. Conditions considered to be outside influence include, but are not limited to, weather, storage practices, contamination, use of unapproved fuels, coolants, lubricants, additives, fertilizers, water, or chemicals, etc.
- Failure or performance issues due to the use of fuels (e.g. gasoline, diesel, or biodiesel) that do not conform to their respective industry standards.

### Countries Other than the United States or Canada

Customers who have purchased Toro products exported from the United States or Canada should contact their Toro Distributor (Dealer) to obtain guarantee policies for your country, province, or state. If for any reason you are dissatisfied with your Distributor's service or have difficulty obtaining guarantee information, contact the Toro importer.

- Normal noise, vibration, wear and tear, and deterioration.
- Normal "wear and tear" includes, but is not limited to, damage to seats due to wear or abrasion, worn painted surfaces, scratched decals or windows, etc.

### Parts

Parts scheduled for replacement as required maintenance are warranted for the period of time up to the scheduled replacement time for that part. Parts replaced under this warranty are covered for the duration of the original product warranty and become the property of Toro. Toro will make the final decision whether to repair any existing part or assembly or replace it. Toro may use remanufactured parts for warranty repairs.

### Deep Cycle and Lithium-Ion Battery Warranty:

Deep cycle and Lithium-Ion batteries have a specified total number of kilowatt-hours they can deliver during their lifetime. Operating, recharging, and maintenance techniques can extend or reduce total battery life. As the batteries in this product are consumed, the amount of useful work between charging intervals will slowly decrease until the battery is completely worn out. Replacement of worn out batteries, due to normal consumption, is the responsibility of the product owner. Battery replacement may be required during the normal product warranty period at owner's expense. Note: (Lithium-Ion battery only): A Lithium-Ion battery has a part only prorated warranty beginning year 3 through year 5 based on the time in service and kilowatt hours used. Refer to the *Operator's Manual* for additional information.

### Maintenance is at Owner's Expense

Engine tune-up, lubrication, cleaning and polishing, replacement of filters, coolant, and completing recommended maintenance are some of the normal services Toro products require that are at the owner's expense.

### General Conditions

Repair by an Authorized Toro Distributor or Dealer is your sole remedy under this warranty.

**Neither The Toro Company nor Toro Warranty Company is liable for indirect, incidental or consequential damages in connection with the use of the Toro Products covered by this warranty, including any cost or expense of providing substitute equipment or service during reasonable periods of malfunction or non-use pending completion of repairs under this warranty. Except for the Emissions warranty referenced below, if applicable, there is no other express warranty. All implied warranties of merchantability and fitness for use are limited to the duration of this express warranty.**

Some states do not allow exclusions of incidental or consequential damages, or limitations on how long an implied warranty lasts, so the above exclusions and limitations may not apply to you. This warranty gives you specific legal rights, and you may also have other rights which vary from state to state.

### Note regarding engine warranty:

The Emissions Control System on your Product may be covered by a separate warranty meeting requirements established by the U.S. Environmental Protection Agency (EPA) and/or the California Air Resources Board (CARB). The hour limitations set forth above do not apply to the Emissions Control System Warranty. Refer to the Engine Emission Control Warranty Statement supplied with your product or contained in the engine manufacturer's documentation for details.