



Z-Master
48" Collection System OFZ
Model No. 79434 – 890523 & Up

Parts Catalog

ORDERING REPLACEMENT PARTS

To order replacement parts, please supply: the part number, the quantity, and the description of each part desired.

Contents

Description	Page	Description	Page
Plenum And Discharge Bracket	1	Grass Bin And Chute Asm	4
Blower Assembly	2	Note:	
Bumper Asm	3		

Part Description Abbreviations

Part descriptions in this catalog may include the following abbreviations.

Abbreviation	Meaning	Abbreviation	Meaning
AR	as required	HWHTF	hex washer head thread forming
ASM	assembly	INC	incorporated
CARR	carriage	LH	left hand
DEG	degrees	PH	pan head
FH	flat head	PPH	Phillips pan head
GA	gauge	PTO	power take off
HF	hex flange	RH	right hand
HFW	hex flange washer	SFH	slotted fillister head
HH	hex head	SH	square head
HHF	hex head flange	SHWH	slotted hex washer head
HHST	hex head self tapping	SPH	slotted pan head
HJ	hex jam	STD	standard
HOC	height-of-cut	TAP	self tapping
HS	hex socket	TH	truss head
HSBH	hex socket button head	TTH	Torx truss head
HSFH	hex socket flat head	WH	wing head
HSH	hex socket head		
HWH	hex washer head		

Important Format Explanations

This catalog uses special formats to convey information in illustrations and parts lists. Specifically, one format is used in conjunction with service assemblies and another with quantities associated with reference numbers.

Service Assemblies

Parts within service assemblies have reference numbers in the form X:Y. X is the reference number of the service assembly and Y is a sequential number unique to each part within the service assembly.

For example, a wheel assembly might be identified by reference number 6, the tire by 6:1, the valve by 6:2, and the wheel by 6:3. When you order the assembly identified by reference number 6, you receive all parts identified by reference numbers 6:1, 6:2, and 6:3. However, you may also order any part individually.

Reference numbers of this type appear in part lists and as callouts in illustrations.

Reference Numbers with Quantities

Illustrations may have a quantity in parentheses next to a reference number, in the form X (Y). X is the reference number. Y in parentheses is the quantity of the part identified by the reference number.

For example, the illustration callout 4 (2) indicates that two parts are used in that instance.

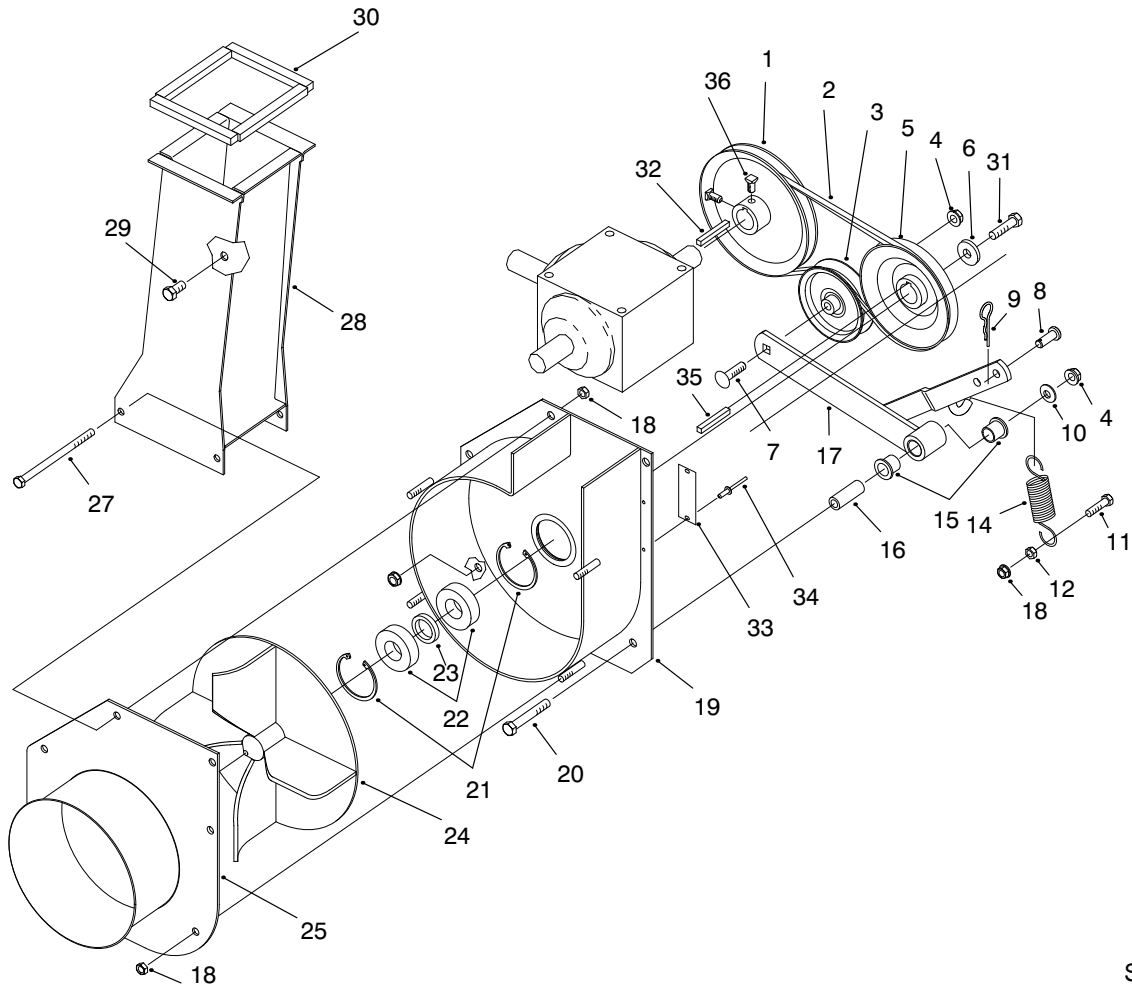

Blower Assembly

Ref. No.	Part No.	Qty.	Description
1	94-4630	1	Pulley-Cast
2	19-2650	1	V-Belt
3	56-4920	1	Pulley-Idler
4	32128-21	4	Nut-HF
5	95-6438	1	Pulley-Impeller
6	65-8680	1	Washer
7	3231-4	1	Bolt-CARR
8	283-2	1	Pin-Clevis
9	3290-467	1	Pin-Cotter
10	3256-3	1	Washer-Flat
11	322-6	1	Screw-HH
12	3217-6	1	Nut-Hex
14	67-1440	1	Spring-Ext
15	256-90	2	Bushing-Flange
16	95-6448	1	Spacer
17	95-6437	1	Idler Arm ASM
18	32128-25	7	Nut-Hex Flange
19	95-6435	1	Housing ASM
20	323-12	1	Screw
21	32120-8	2	Snap Ring (N5000-206)
22	251-82	2	Bearing-Ball
23	95-6427	1	Spacer-Bearing
24	95-6434	1	Impeller ASM
25	95-6436	1	Cover ASM
27	322-29	2	Screw-HH

Ref. No.	Part No.	Qty.	Description
28	95-4345	1	Impeller Chute ASM
29	323-4	1	Screw-HH
30	98-0824	4	Strip-Foam
31	323-5	1	Screw-HH
32	67-7490	1	Key
33	3-5584	1	Plate-Serial Number
34	3290-271	2	Rivet-Pop
35	10-7070	1	Key-Sq
36	3242-4	2	Screw-Set

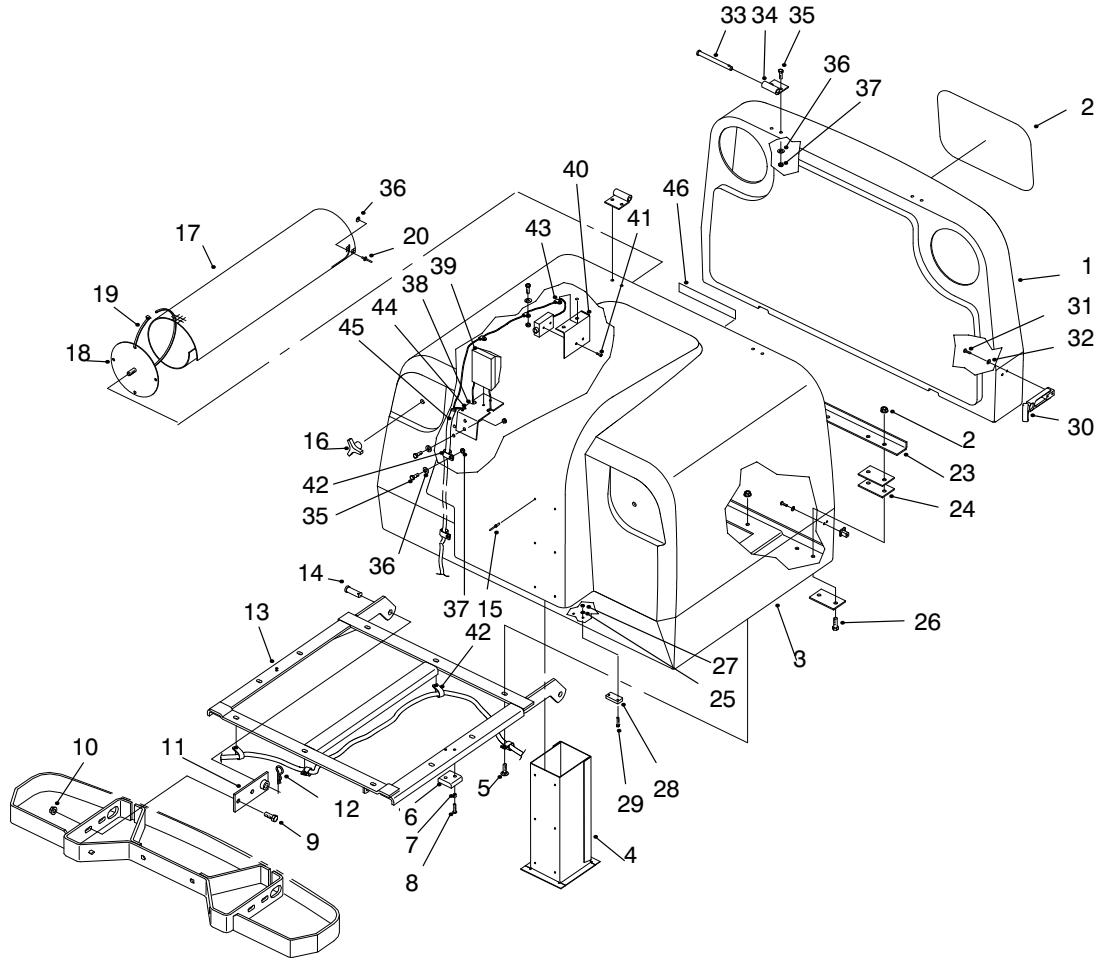

Sheet No.: 5

Grass Bin And Chute Asm

Ref. No.	Part No.	Qty.	Description
1	95-6423	1	Cover-Bin
2	32128-25	14	Nut-Hex Flange
3	95-6422	1	Bin-Grass
4	95-6482	1	Chute ASM
5	3230-16	6	Screw-CARR
6	98-3031	2	Cushion
9	323-6	4	Screw-HH
10	32128-21	4	Nut-HF
11	95-6431	2	Pivot ASM
12	3290-355	2	Pin-Hair
13	95-6418	1	Frame ASM
14	283-68	2	Pin-Clevis
15	98-7310	4	Rivet
16	233-52	2	Knob-Black
17	95-6441	2	Screen
18	95-6444	2	Plate ASM
19	3290-378	8	Tie-Cable
20	3290-412	8	Pop Rivet-.25
22	67-7310	1	Decal-Toro Logo
23	98-0849	1	Flange-Bin
24	98-3004	6	Spacer
25	3256-12	2	Washer-Flat
26	322-6	4	Screw-HH
27	3296-9	2	Nut-Lock 6-32
28	98-3006	1	Actuator
29	3290-124	2	Screw-HH

Ref. No.	Part No.	Qty.	Description
30	94-5626	2	Latch-Draw
31	3290-359	6	Screw-Rd
32	3256-21	6	Washer-Flat
34	98-3027	4	Hinge
35	321-4	16	Screw-HH
36	3256-22	20	Washer-Flat
37	3296-42	16	Nut-Lock
38	98-3000	1	Bracket-Receiver
39	98-2367	1	Module-Obstruction Detec
40	98-3001	1	Bracket-Emitter
41	3250-19	4	Screw-Phm 8-32 X .375
42	2412-93	6	R-Clamp
43	2412-127	3	Clip
44	3290-381	3	Tie-Cable
45	98-3009	1	Conduit-Convuluted
46	3234-17	4	Screw-Hfh 5/16-18x1
47	98-3036	1	Angle-Bin
48	323-16	2	Screw-HH
49	3296-39	2	Nut-Lock
50	2412-138	1	Clamp-R .56id X .75

Toro Part Number Index

Part No.	Page No.	Ref. No.	Qty.	Description
3-5584	2	33	1	Plate-Serial Number
10-7070	2	35	1	Key-Sq
19-2650	2	2	1	V-Belt
56-4920	2	3	1	Pulley-Idler
65-8680	2	6	1	Washer
67-1440	2	14	1	Spring-Ext
67-7310	4	22	1	Decal-Toro Logo
67-7490	2	32	1	Key
79-0360	3	12	1	Decal-Danger
88-6770	3	5	2	Stud-Ball
94-4630	2	1	1	Pulley-Cast
94-5626	3	16	1	Latch-Draw
94-5626	4	30	2	Latch-Draw
95-4323	1	1	1	Plenum
95-4345	2	28	1	Impeller Chute ASM
95-6414	3	1	1	Bumper ASM
95-6418	4	13	1	Frame ASM
95-6422	4	3	1	Bin-Grass
95-6423	4	1	1	Cover-Bin
95-6427	2	23	1	Spacer-Bearing
95-6431	4	11	2	Pivot ASM
95-6434	2	24	1	Impeller ASM
95-6435	2	19	1	Housing ASM
95-6436	2	25	1	Cover ASM
95-6437	2	17	1	Idler Arm ASM
95-6438	2	5	1	Pulley-Impeller
95-6441	4	17	2	Screen
95-6444	4	18	2	Plate ASM
95-6448	2	16	1	Spacer
95-6482	4	4	1	Chute ASM
95-7669	3	9	1	Switch-Reed
98-0823	3	8	1	Bracket-Switch
98-0824	2	30	4	Strip-Foam
98-0843	1	11	1	Guard-Plenum
98-0849	4	23	1	Flange-Bin
98-2367	4	39	1	Module-Obstruction Detec
98-3000	4	38	1	Bracket-Receiver
98-3001	4	40	1	Bracket-Emitter
98-3002	1	4	1	Bracket-Discharge
98-3003	1	8	1	Bracket-Discharge
98-3004	4	24	6	Spacer
98-3006	4	28	1	Actuator
98-3009	4	45	1	Conduit-Convoluted
98-3015	1	12	1	Baffle-LH
98-3016	1	13	1	Baffle-RH
98-3027	4	34	4	Hinge
98-3031	4	6	2	Cushion
98-3032	3	13	1	Bracket-Latch
98-3035	1	16	1	Bracket-Spring
98-3036	4	47	1	Angle-Bin
98-3037	1	15	1	Spring-Extension
98-3043	3	4	1	Spring-Gas
98-3044	3	19	2	Clip-Safety
98-7310	4	15	4	Rivet
98-7316	1	2	1	Bracket-Plenum
98-7317	1	6	1	Bracket-Hinge
233-52	4	16	2	Knob-Black
2412-93	4	42	6	R-Clamp
2412-127	4	43	3	Clip
2412-138	4	50	1	Clamp-R .56id X .75
251-82	2	22	2	Bearing-Ball
256-90	2	15	2	Bushing-Flange

*Not Illustrated

Toro Part Number Index (cont.)

Part No.	Page No.	Ref. No.	Qty.	Description
283-2	2	8	1	Pin-Clevis
283-49	1	17	1	Pin-Clevis
283-68	4	14	2	Pin-Clevis
321-4	4	35	16	Screw-HH
322-6	2	11	1	Screw-HH
322-6	4	26	4	Screw-HH
322-29	2	27	2	Screw-HH
323-4	2	29	1	Screw-HH
323-5	2	31	1	Screw-HH
323-6	4	9	4	Screw-HH
323-12	2	20	1	Screw
323-16	4	48	2	Screw-HH
325-4	3	14	1	Screw-HH
325-5	3	7	2	Screw-HH
325-11	3	6	2	Screw-HH
3217-6	2	12	1	Nut-Hex
3229-25	1	5	2	Screw-CARR
3230-16	4	5	6	Screw-CARR
3230-23	1	9	10	Bolt-CARR
3231-2	3	20	1	Screw-CARR
3231-4	2	7	1	Bolt-CARR
3234-17	4	46	4	Screw-Hfh 5/16-18x1
3242-4	2	36	2	Screw-Set
3250-19	4	41	4	Screw-Phm 8-32 X .375
3256-3	2	10	1	Washer-Flat
3256-12	4	25	2	Washer-Flat
3256-21	3	18	1	Washer-Flat
3256-21	4	32	6	Washer-Flat
3256-22	4	36	20	Washer-Flat
3256-26	3	15	1	Washer-Flat
3269-4	1	14	4	Rivet-Pop
3269-25	1	3	3	Rivet-Pop
3290-124	4	29	2	Screw-HH
3290-250	1	18	1	Pin-Cotter
3290-271	2	34	2	Rivet-Pop
3290-313	3	10	2	Screw-PH
3290-355	4	12	2	Pin-Hair
3290-359	3	17	3	Screw-Rd
3290-359	4	31	6	Screw-Rd
3290-378	4	19	8	Tie-Cable
3290-381	4	44	3	Tie-Cable
3290-412	4	20	8	Pop Rivet-.25
3290-467	2	9	1	Pin-Cotter
3296-9	4	27	2	Nut-Lock 6-32
3296-39	4	49	2	Nut-Lock
3296-42	4	37	16	Nut-Lock
3296-52	3	11	2	Nut-Lock
32120-8	2	21	2	Snap Ring (N5000-206)
32128-13	1	10	10	Nut-Lock Flange
32128-21	2	4	4	Nut-HF
32128-21	4	10	4	Nut-HF
32128-23	3	3	5	Nut-Lock
32128-25	2	18	7	Nut-Hex Flange
32128-25	4	2	14	Nut-Hex Flange
32128-32	1	7	2	Nut-Hex Flange
32152-1	3	2	2	Nut-Lock

*Not Illustrated