

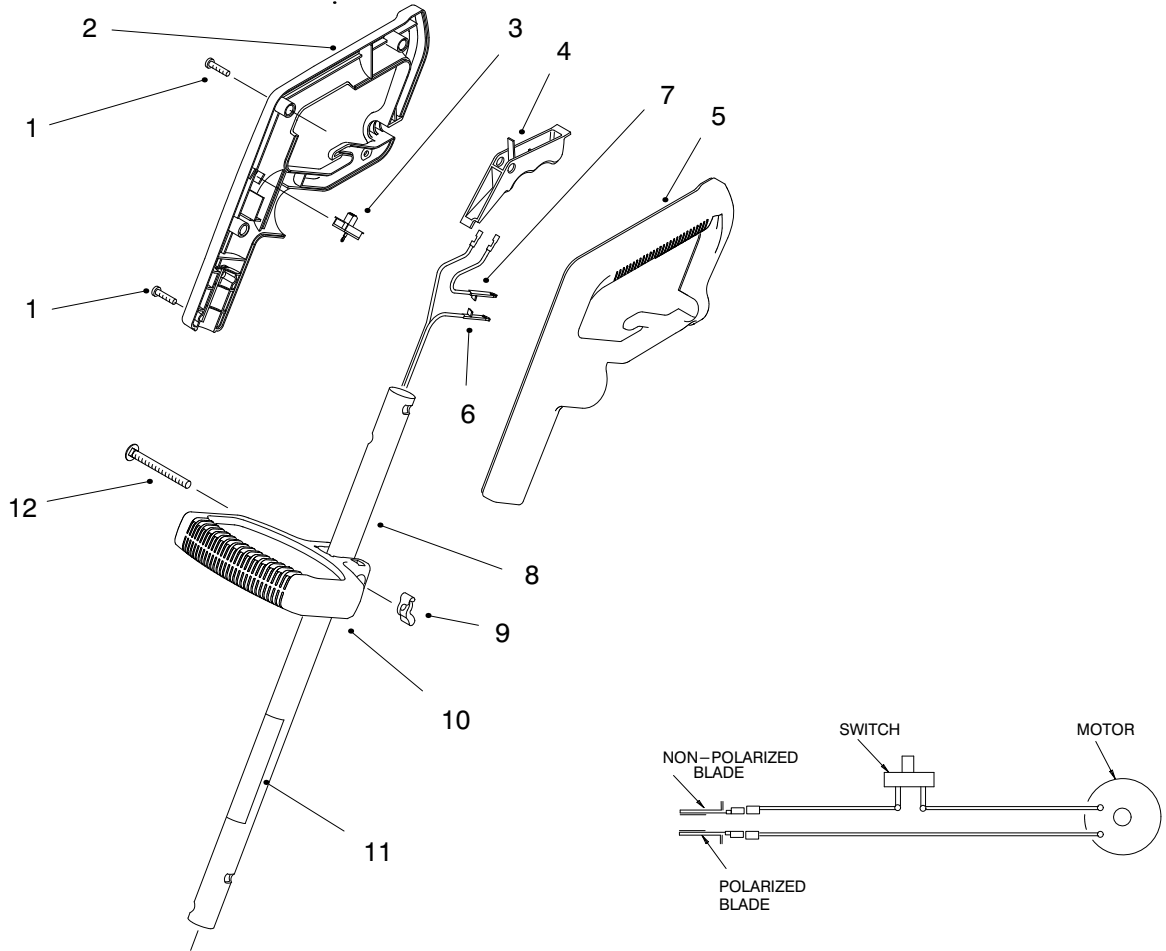

MODEL NO. 51302-8900001 & UP
 MODEL NO. 51305-8900001 & UP

PARTS
 CATALOG

13" ELECTRIC TRIMMER



HANDLE ASSEMBLY

| Ref. No. | Part No. | Description | No. Used |
|----------|----------|-----------------------|----------|
| 1 | 94-4496 | Screw | 6 |
| 2 | 98-1839 | Grip - Hand R.H. | 1 |
| 3 | 73-5600 | Switch - Single Speed | 1 |
| 4 | 73-8170 | Trigger | 1 |
| 5 | 98-1840 | Grip - Hand L.H. | 1 |
| 6 | 98-1849 | Harness - Wire | 1 |
| 7 | 98-1837 | ASM-Wire | 2 |

| Ref. No. | Part No. | Description | No. Used |
|----------|----------|-----------------------------------|----------|
| 8 | 98-7183 | Tube Assembly (Incl. Ref. #11) | 1 |
| 9 | 32103-30 | Nut - Wing | 1 |
| 10 | 73-8310 | Handle - Mid | 1 |
| 11 | 98-7184 | Decal - Safety | 1 |
| 12 | 73-8740 | Screw - Carriage | 1 |

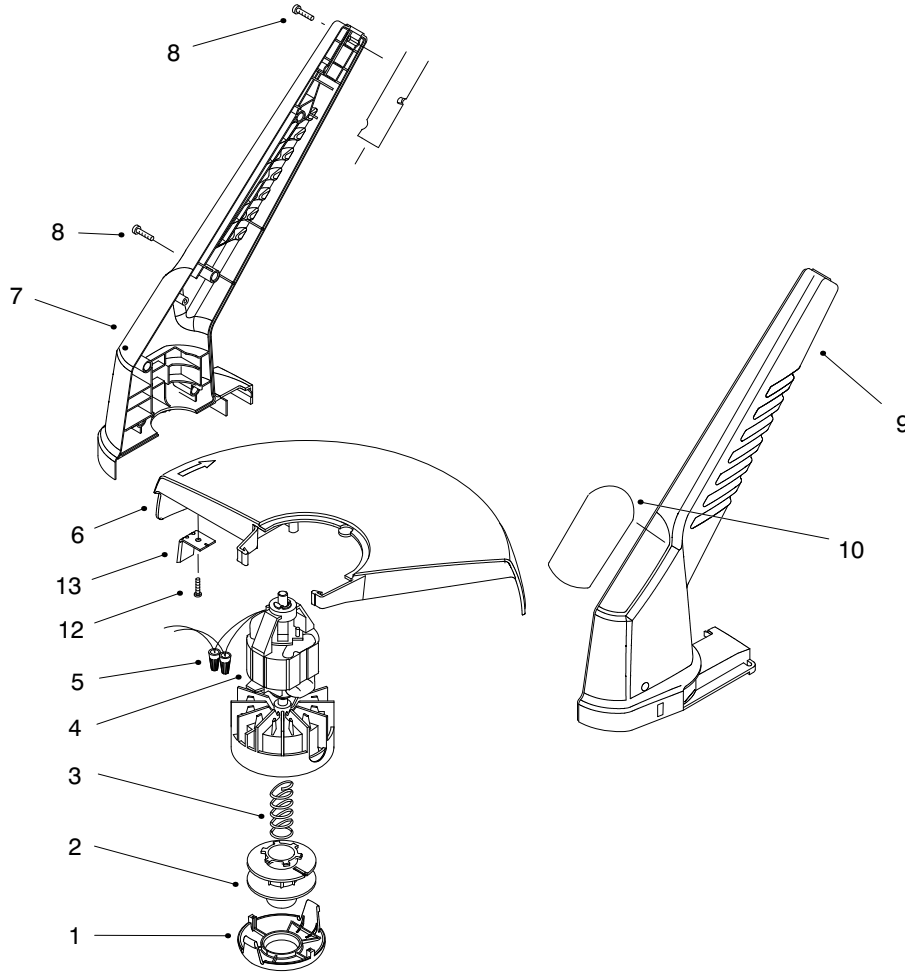

MOTOR & HOUSING ASSEMBLY

| Ref. No. | Part No. | Description | No. Used |
|----------|----------|--|----------|
| 1 | 73-8200 | Cap | 1 |
| 2 | 73-8190 | Spool | 1 |
| 3 | 73-8220 | Spring | 1 |
| 4 | 73-9051 | Motor Assembly | 1 |
| 5 | 73-6570 | Connector - Wire Nut | 2 |
| 6 | 98-9275 | Shield Asm. - 13" (Incl. Ref. #12 and 13) | 1 |
| 7 | 98-1841 | Housing R.H. | 1 |

| Ref. No. | Part No. | Description | No. Used |
|----------|----------|---|----------|
| 8 | 94-4496 | Screw - Pan Hd. | 6 |
| 9 | 98-1842 | Housing L.H. | 1 |
| 10 | 98-3306 | Decal - 13" Trimmer | 1 |
| 12 | 94-6961 | Screw | 1 |
| 13 | 98-1848 | Blade | 1 |
| * | 88175 | Spool & Line Assembly (Whole Goods) (Incl. Ref. #2 and 30 ft of .065 line) | 1 |

*Not Illustrated