



HoverPro 450 Machine

Model No. 02612—Serial No. 315000001 and Up

Operator's Manual

Introduction

Read this information carefully to learn how to operate and maintain your product properly and to avoid injury and product damage. You are responsible for operating the product properly and safely. Keep this manual for future reference.

You may contact Toro directly at www.Toro.com for product safety and operation training materials, accessory information, help finding a dealer, or to register your product.

Whenever you need service, genuine Toro parts, or additional information, contact an Authorized Service Dealer or Toro Customer Service and have the model and serial numbers of your product ready. **Figure 1** identifies the location of the model and serial numbers on the product.

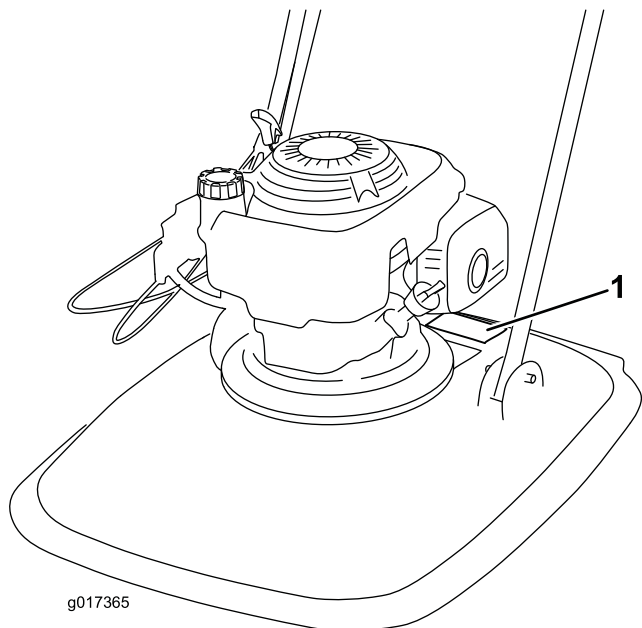

Figure 1

1. Model and serial number plate

Write the product model and serial numbers in the space below:

Model No. _____
Serial No. _____

This manual identifies potential hazards and has safety messages identified by the safety alert symbol (**Figure 2**), which signals a hazard that may cause serious injury or death if you do not follow the recommended precautions.



Figure 2

g000502

1. Safety alert symbol

This manual uses 2 words to highlight information. **Important** calls attention to special mechanical information and **Note** emphasizes general information worthy of special attention.

This product complies with all relevant European directives. For details, see the separate product specific Declaration of Conformity (DOC) sheet.

Net Torque: The gross or net torque of this engine was laboratory rated by the engine manufacturer in accordance with the Society of Automotive Engineers (SAE) J1349. As configured to meet safety, emission, and operating requirements, the actual engine torque on this class of machine will be significantly lower. Go to www.Toro.com to view specifications on your machine model.

Do not tamper with the engine controls or alter the governor speed; doing so may create an unsafe condition resulting in personal injury.

Contents

Introduction	1
Safety	2
General Machine Safety	2
Sound Pressure	4
Sound Power	4
Vibration	4
Safety and Instructional Decals	5
Setup	6
1 Assembling the Handle	6
2 Installing the Footstop	7
3 Filling the Engine with Oil	7
Product Overview	8



Specifications	9
Operation	9
Filling the Fuel Tank	9
Checking the Engine-Oil Level	10
Adjusting the Cutting Height	10
Starting the Engine	11
Adjusting the Choke	12
Stopping the Engine	12
Operating Tips	13
Maintenance	14
Recommended Maintenance Schedule(s)	14
Preparing for Maintenance	15
Replacing the Air Cleaner	15
Changing the Engine Oil	15
Servicing the Spark Plug	16
Replacing the Flexi Blade	16
Cleaning the Machine	17
Storage	17
Preparing the Machine for Storage	17
Troubleshooting	18

Safety

This machine has been designed in accordance with EN 14910.

Improperly using or maintaining this machine can result in injury. To reduce the potential for injury, comply with these safety instructions.

Toro designed and tested this machine to offer reasonably safe service; however, failure to comply with the following instructions may result in personal injury.

To ensure maximum safety and best performance, and to gain knowledge of the product, it is essential that you and any other operator of the machine read and understand the contents of this manual before the engine is ever started. Pay particular attention to the safety alert symbol (Figure 2) which means Caution, Warning, or Danger—“personal safety instruction.” Read and understand the instruction because it has to do with safety. Failure to comply with the instruction may result in personal injury.

General Machine Safety

This cutting machine is capable of amputating hands and feet and of throwing objects. Failure to observe the following safety instructions could result in serious injury or death.

Training

- Read the instructions carefully. Be familiar with the controls and the proper use of the equipment.
- Never allow children or people unfamiliar with these instructions to use the machine. Local regulations can restrict the age of the operator.
- Keep in mind that the operator or user is responsible for accidents or hazards occurring to other people or their property.
- Understand explanations for all pictograms used on the machine or in the instructions.

Gasoline

WARNING-Gasoline is highly flammable. Take the following precautions.

- Store fuel in containers specifically designed for this purpose.
- Refuel outdoors only and do not smoke while refueling.
- Add fuel before starting the engine. Never remove the cap of the fuel tank or add gasoline while the engine is running or when the engine is hot.

- If gasoline is spilled, do not attempt to start the engine but move the machine away from the area of spillage and avoid creating any source of ignition until gasoline vapors have dissipated.
- Replace all fuel tank and container caps securely.

Preparation

- While cutting, always wear substantial, slip-resistant footwear and long trousers. Do not operate the equipment when barefoot or wearing open sandals.
- Thoroughly inspect the area where the equipment is to be used and remove all stones, sticks, wires, bones and other foreign objects.
- Before using, always visually inspect to see that guards and safety devices, such as deflectors, are in place and working correctly.
- Before using, always visually inspect to see that the lines, retaining bolts, and flexi blade assembly are not worn or damaged. Replace worn or damaged lines in sets to preserve balance.
- Wear safety glasses or goggles at all times when operating the trimmer.
- Wear hearing protection.

Starting

- Do not tilt the machine unless the machine must be tilted for starting. In this case, do not tilt it more than absolutely necessary and lift only the part which is away from the operator.
- Start the engine carefully according to instructions and with feet well away from the flexi blade.

Operation

- Never cut while people, especially children, or pets are nearby.
- Cut only in daylight or in good artificial light.
- Avoid operating the trimmer in wet grass, or take additional precautions to avoid slipping.
- Stay alert for holes in the terrain and other hidden hazards.
- Do not put hands or feet near or under rotating parts.
- Never pick up or carry a machine while the engine is running.
- Use extreme caution when reversing or pulling a pedestrian-controlled machine toward you.
- Walk, never run.
- Slopes:
 - Do not cut excessively steep slopes.
 - Watch for holes, ruts, bumps, rocks, or other hidden objects. Uneven terrain could cause

a slip and fall accident. Tall grass can hide obstacles.

- Use caution near drop-offs, ditches, or embankments. You could lose your footing or balance.
- When using the machine, always keep both hands on the handlebar.
- When cutting steep slopes from the top of the slope and a longer reach is needed, never tie the machine to a rope; use the extended handlebar kit option.
- Exercise extreme caution when on slopes.
- Always be sure of your footing on slopes.
- Stop the engine if the machine must be tilted for transportation when crossing surfaces other than grass and when transporting the machine to and from the area to be cut.
- Do not operate the engine in a confined space where dangerous carbon monoxide and other exhaust gasses can collect.
- Stop the engine
 - whenever you leave the machine.
 - before refueling.
 - before making height adjustment unless adjustment can be made from the operating position.
- Stop the engine and disconnect the spark-plug wire.
 - before clearing blockages.
 - before checking, cleaning or working on the machine.
 - after striking a foreign object, inspect the machine for damage and make repairs before restarting and operating the machine.
 - if the machine starts to vibrate abnormally (check immediately).
- Lightning can cause severe injury or death. If you see lightning or hear thunder in the area, do not operate the machine; seek shelter.
- Watch out for traffic when crossing or near roadways.

Maintenance and Storage

- Keep all nuts, bolts, and screws tight to be sure that the equipment is in safe working condition.
- Do not use pressure-cleaning equipment on the machine.
- Never store the equipment with gasoline in the tank and inside a building where fumes can reach an open flame or spark.
- Allow the engine to cool before storing in any enclosure.

- To reduce the fire hazard, keep the engine, silencer, battery compartment and gasoline storage area free of grass, leaves, or excessive grease.
- Replace worn or damaged parts for safety.
- Replace faulty silencers.
- If the fuel tank has to be drained, do this outdoors.
- Do not change the engine governor settings or overspeed the engine. Operating an engine at excessive speed can increase the hazard of personal injury.
- Be careful while adjusting the machine to prevent entrapment of the fingers between the moving flexi blade and fixed parts of the machine.
- **To ensure the best performance and safety, purchase only genuine Toro replacement parts and accessories. Do not use *will fit* parts and accessories; they may cause a safety hazard.**

Measured vibration level for the left hand = 5.5 m/s²

Uncertainty Value (K) = 3 m/s²

The measured values were determined according to the procedures outlined in EN 14910.

⚠ CAUTION

Long-term exposure to vibration while operating the machine may cause some numbness in the hands and wrists.

Wear gloves that dampen the vibration whenever you operate the machine for an extended period of time.

Hauling

- Use care when loading or unloading the machine into a trailer or a truck.
- Tie the machine down securely using straps, chains, cable, or ropes.

Sound Pressure

This machine has a sound pressure level at the operator's ear of 90 dBA. This includes an Uncertainty Value (K) of 2 dBA. The sound pressure level was determined according to the procedures outlined in EN 14910.

Sound Power

This machine has a guaranteed sound power level of 100 dBA. This includes an Uncertainty Value (K) of 2 dBA. The sound power level was determined according to the procedures outlined in ISO 11094.

⚠ CAUTION

Long-term exposure to noise while operating the machine may cause some hearing loss.

Wear adequate hearing protection whenever you operate the machine for an extended period of time.

Vibration

Measured vibration level for the left hand = 7.7 m/s²

Safety and Instructional Decals

Important: Safety and instruction decals are located near areas of potential danger. Replace damaged decals.

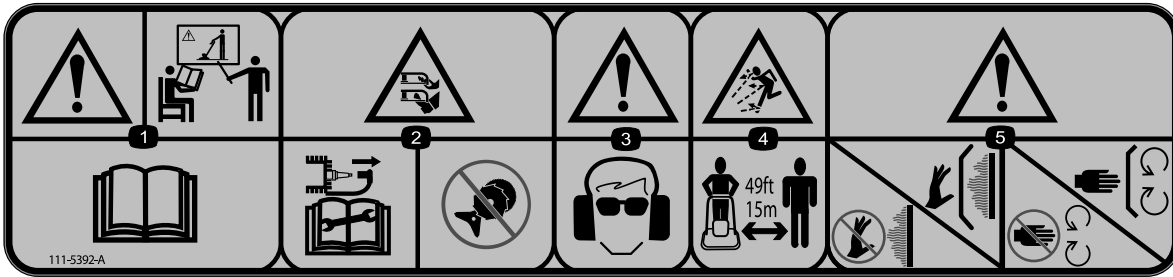

111-5392-A

decal111-5392

111-5392

1. Warning—Receive training on the product; read the *Operator's Manual*.
2. Cutting/dismemberment hazard of hand or foot, Flexi blade line; disconnect the wire from the spark plug before working on the machine; never fit metal cutting parts.
3. Warning—wear eye and hearing protection.
4. Thrown object hazard; keep bystanders at least 15m (49ft) from the machine.
5. Warning—do not touch hot surfaces; keep guards in place; Stay away from moving parts; keep guards in place.



94-8072

decal94-8072

1. Warning—cutting/dismemberment hazard of hand or foot, cutting mechanism.



g017410

g017410

H295159

1. Engine stop



g017409

H295124

g017409

1. Instruction for orientation of the machine for servicing the cutting mechanism and draining oil.



g017414

g017414

1. Choke
2. Engine symbol
3. Run

Setup

1

Assembling the Handle

No Parts Required

Procedure

1. Slide 2 bushings into the frame.

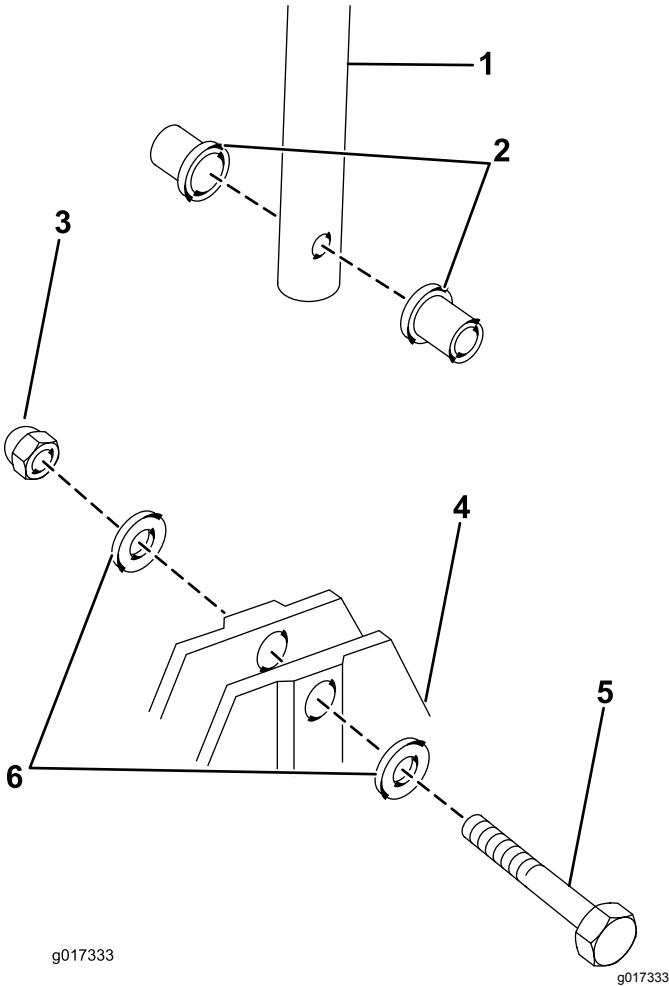

Figure 3

- | | |
|-----------------|------------|
| 1. Lower handle | 4. Frame |
| 2. Bushes | 5. Bolt |
| 3. Nut | 6. Washers |

2. Place the lower handle between the bushes and secure it with 1 handlebar bolt, 2 washers, and 1 nut.

Note: Place the lower handle between the bushes with the kick stop assembly on the right hand side.

3. Repeat for the opposite side.
4. Align the holes on the upper handle with the lower handle.

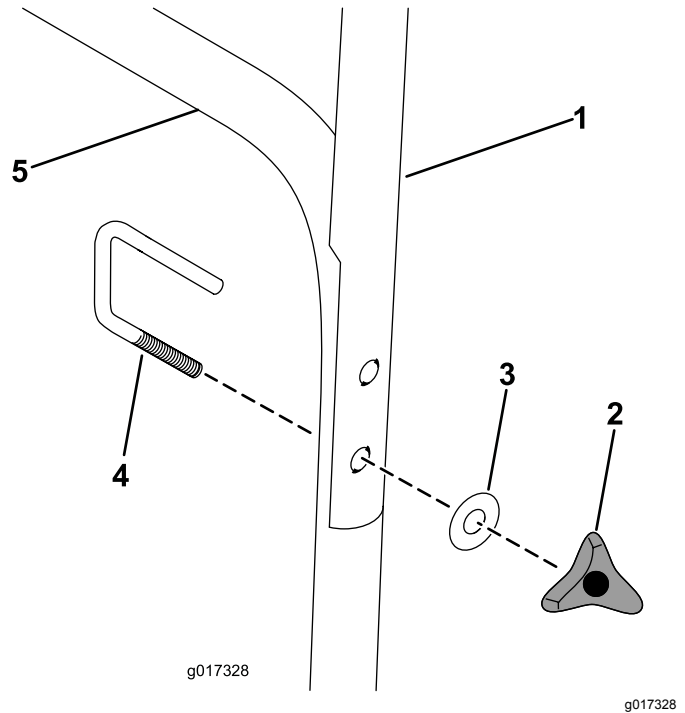

Figure 4

- | | |
|-----------------|-----------------|
| 1. Upper handle | 4. U-bolt |
| 2. Hand wheel | 5. Lower handle |
| 3. Washer | |

5. Fit the U-bolt through the upper and lower handle and secure it with a washer and a hand wheel.
6. Attach the throttle assembly to the outside of the handlebar and secure it with a nut and a pan screw.

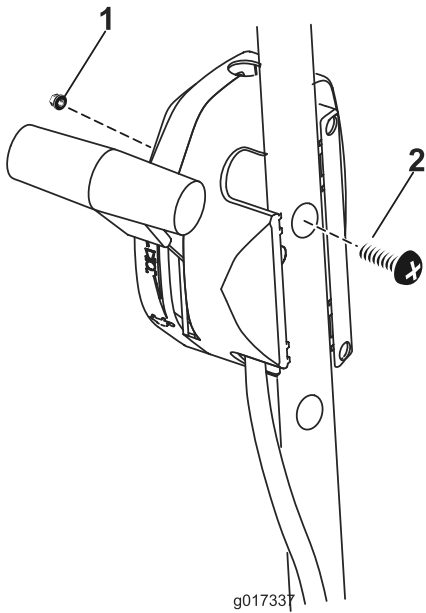

Figure 5

1. Nut
2. Pan Screw

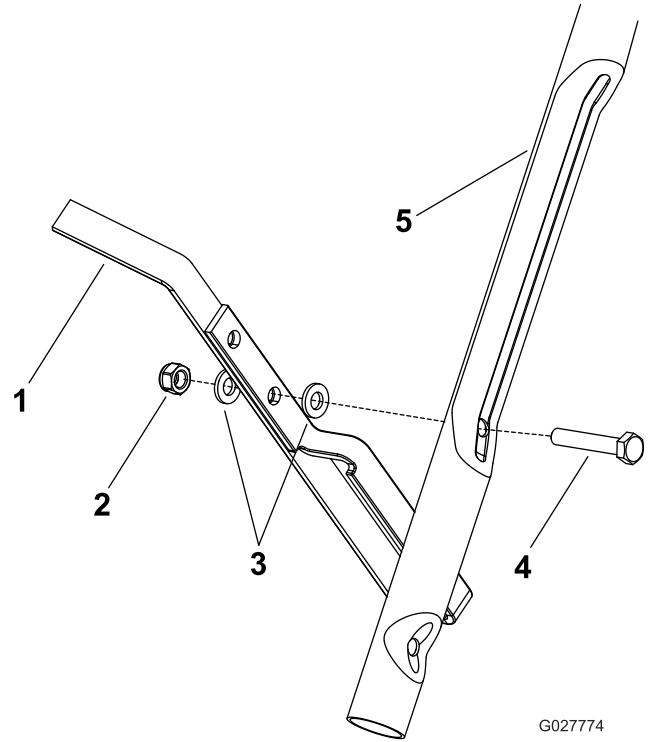

Figure 6

1. Footstop
2. Nut
3. Washer
4. Bolt
5. Lower handle

2

Installing the Footstop

No Parts Required

Procedure

Secure the footstop to the bolt on the right side of the lower handle using a nut and 2 washers (Figure 6).

Note: Install the footstop using the lower hole in the footstop as shown in Figure 6.

3

Filling the Engine with Oil

No Parts Required

Procedure

Important: Your machine does not come with oil in the engine. Before starting the engine, fill the engine with oil.

Max. fill: 0.59 L (20 oz), type: Multigrade Mineral 10W-30 oil with an API service classification of SF, SG, SH, SJ, SL, or higher.

1. Move the machine to a level surface.
2. Remove the dipstick (Figure 7).

Product Overview

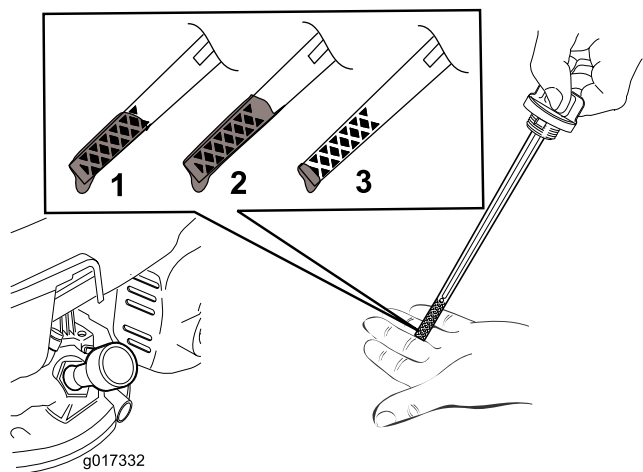

Figure 7

1. Full
2. High
3. Low

3. **Slowly** pour oil into the oil fill hole, wait 3 minutes, and check the oil level on the dipstick by wiping the dipstick clean and then inserting, **but not screwing in**, the oil fill cap into the hole (Figure 8).

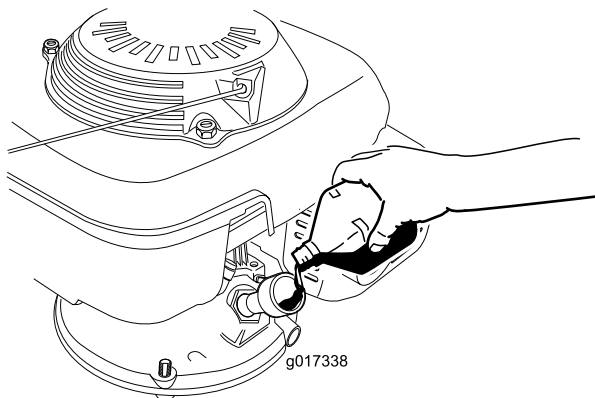

Figure 8

Note: Fill the engine crankcase with oil until the dipstick indicates that the engine oil level is correct as shown in Figure 7. If you overfill the engine with oil, remove the excess oil as directed in Changing the Engine Oil.

4. Install the dipstick and hand tighten it securely.

Important: Change the engine oil after the first 5 operating hours; change it yearly thereafter. Refer to Changing the Engine Oil.

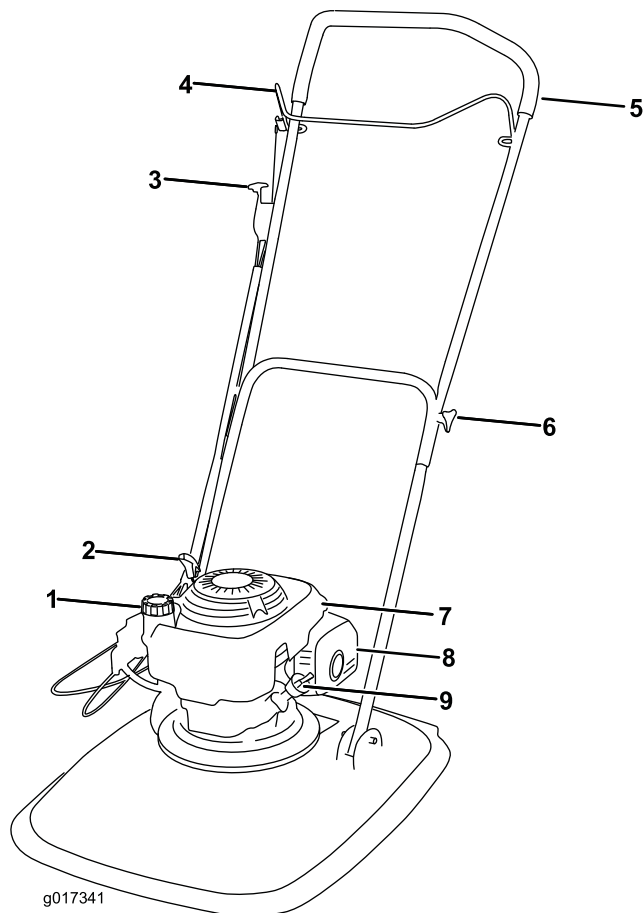

Figure 9

- | | |
|-----------------------|-------------------|
| 1. Fuel cap | 6. Handlebar knob |
| 2. Engine start | 7. Exhaust guard |
| 3. Throttle control | 8. Engine cover |
| 4. Engine stop handle | 9. Dipstick |
| 5. Handlebar | |

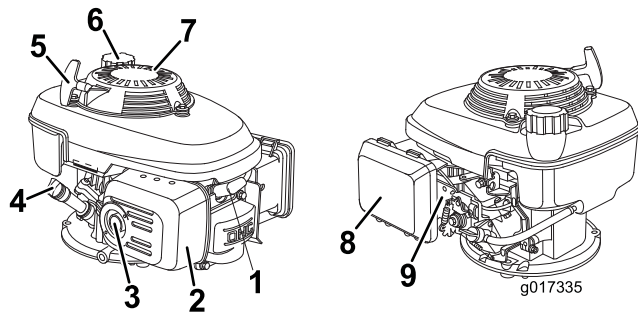

Figure 10

- | | |
|------------------|-----------------|
| 1. Spark plug | 6. Fuel cap |
| 2. Exhaust guard | 7. Finger guard |
| 3. Exhaust | 8. Air cleaner |
| 4. Dipstick | 9. Carburetor |
| 5. Starter grip | |

Specifications

Model	Cutting width	Product width	Product height	Length	Weight	Engine rpm	Cutting height range
02612	457 mm (18 inches)	574 mm (22.6 inches)	1000 mm (39.3 inches)	1,400 mm (55 inches)	17.7 kg (39 lbs)	3,150 +0/-100	16 mm – 36 mm (0.6 inches – 1.4 inches)

Operation

Filling the Fuel Tank

⚠ DANGER

Gasoline is extremely flammable and explosive. A fire or explosion from gasoline can burn you and others.

- To prevent a static charge from igniting the gasoline, place the container and/or machine directly on the ground before filling, not in a vehicle or on an object.
- Fill the tank outdoors when the engine is cold. Wipe up spills.
- Do not handle gasoline when smoking or around an open flame or sparks.
- Store gasoline in an approved fuel container, out of the reach of children.

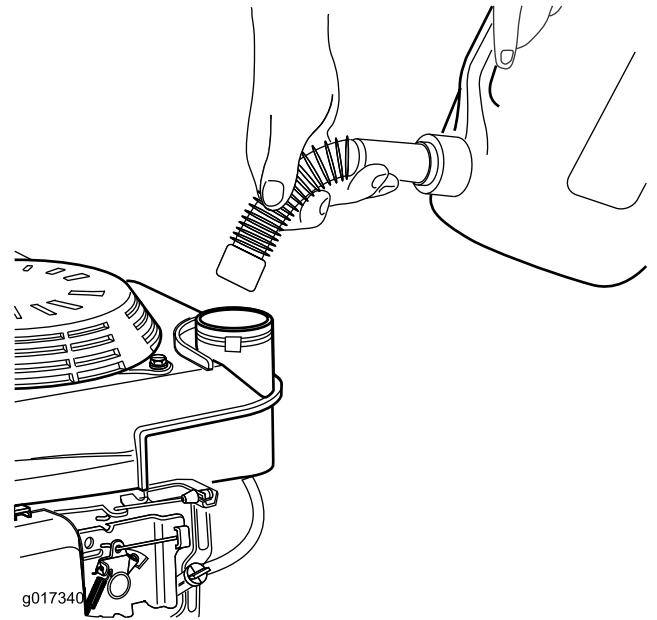

Figure 11

g017340

Recommended Fuel:

- For best results, use only clean, fresh (less than 30 days old), unleaded gasoline with an octane rating of 87 or higher ((R+M)/2 rating method).
- **Ethanol:** Gasoline with up to 10% ethanol (gasohol) or 15% MTBE (methyl tertiary butyl ether) by volume is acceptable. Ethanol and MTBE are not the same. Gasoline with 15% ethanol (E15) by volume is not approved for use. **Never use** gasoline that contains more than 10% ethanol by volume, such as E15 (contains 15% ethanol), E20 (contains 20% ethanol), or E85 (contains 85% ethanol). Using unapproved gasoline may cause performance problems and/or engine damage which may not be covered under warranty.
- **Do not** use gasoline containing methanol.
- **Do not** store fuel either in the fuel tank or fuel containers over the winter unless a fuel stabilizer is used.
- **Do not** add oil to gasoline.

Checking the Engine-Oil Level

Service Interval: Before each use or daily

1. Move the machine to a level surface.
2. Remove the dipstick and wipe it with a clean cloth.
3. Insert, **but do not screw in**, the dipstick into the oil fill hole.
4. Remove the dipstick and check it.
5. To determine the proper oil level on the dipstick, refer to [Figure 12](#)).

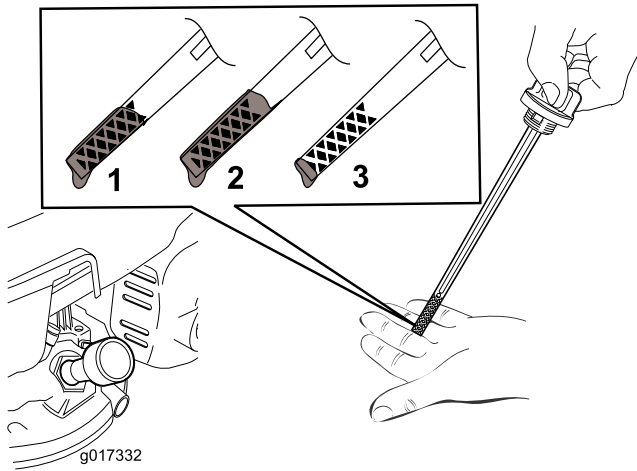

Figure 12

1. The oil level is at its maximum.
2. The oil level is too high—remove oil from the crankcase.
3. The oil level is too low—add oil to the crankcase.

6. If the oil level is low, **slowly** pour oil into the oil fill hole, wait 3 minutes, and check the oil level on the dipstick by wiping the dipstick clean and then inserting, **but not screwing in**, the oil fill cap into the hole.

Note: Max. fill: 0.59 L (20 oz) Multigrade Mineral 10W-30 oil with an API service classification of SF, SG, SH, SJ, SL, or higher.

Note: Fill the engine crankcase with oil until the dipstick indicates that the engine oil level is correct as shown in [Figure 12](#). If you overfill the engine with oil, remove the excess oil as directed in Changing the Engine Oil.

7. Install the dipstick and hand tighten it securely.

Important: Change the engine oil after the first 5 operating hours; change it yearly thereafter. Refer to [\(page \)](#).

Adjusting the Cutting Height

⚠ WARNING

Adjusting the cutting height may bring you into contact with moving parts, causing serious injury.

- Stop the engine and wait for all moving parts to stop.
- Wear gloves while handling the flexi blade.

⚠ CAUTION

If the engine has been running, the muffler will be hot and can severely burn you. Keep away from the hot muffler.

Adjust the cutting height as desired.

1. Turn the fuel switch to the Off position.
2. Disconnect the wire from the spark plug.
3. Tilt the machine on its left side.
4. **Wearing protective gloves**, remove the flexi blade.
5. Remove the retaining bolt.
6. Reposition the spacers to the desired height, then reinstall the flexi blade ([Figure 13](#)).

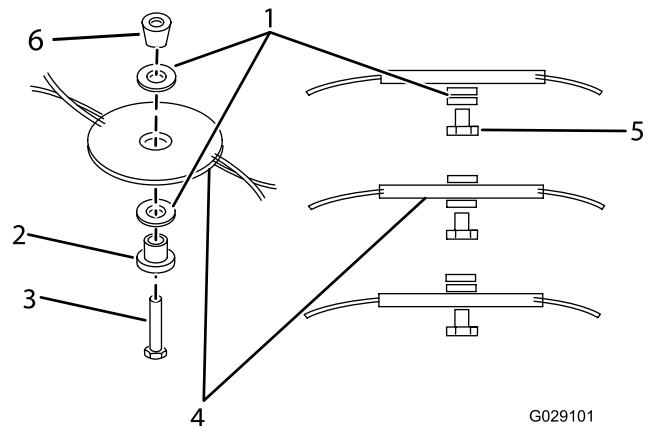

Figure 13

1. Spacers
2. Retainer
3. Bolt
4. Flexi blade
5. Retainer
6. Large spacer

Note: The large spacer must be positioned directly below the impeller at all times.

Starting the Engine

1. Place the throttle control to the choke position, ensure that the fuel switch is in the On position.

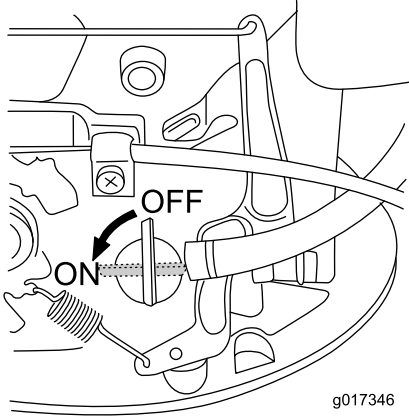

Figure 14



Figure 16

2. Hold the engine-stop handle against the handle.

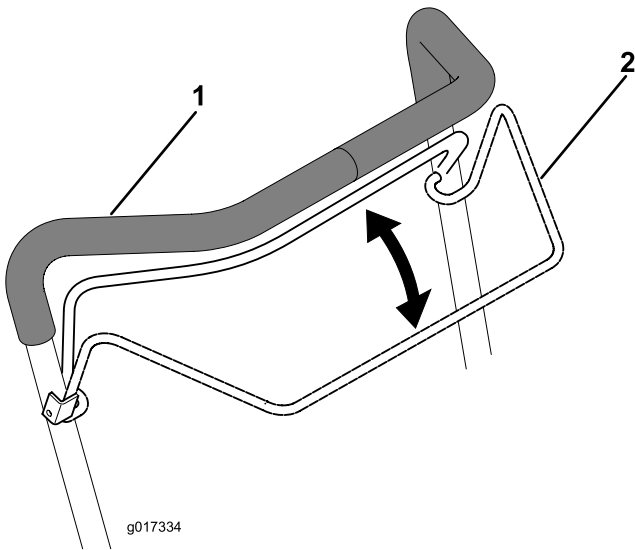

Figure 15

1. Handle
2. Engine stop handle

3. Place your foot on the deck and tilt the machine towards you (Figure 16).

4. Pull the recoil start handle.

Note: If the machine does not start after several attempts, contact an Authorized Service Dealer.

Adjusting the Choke

Use the throttle assembly to adjust the choke (Figure 17).

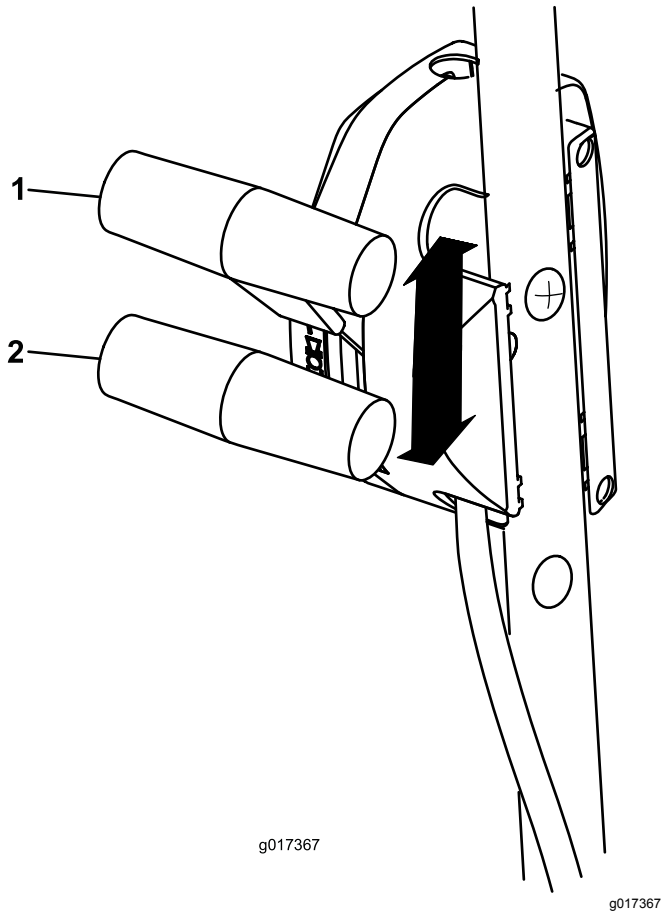

Figure 17

- 1. Choke on
- 2. Choke off

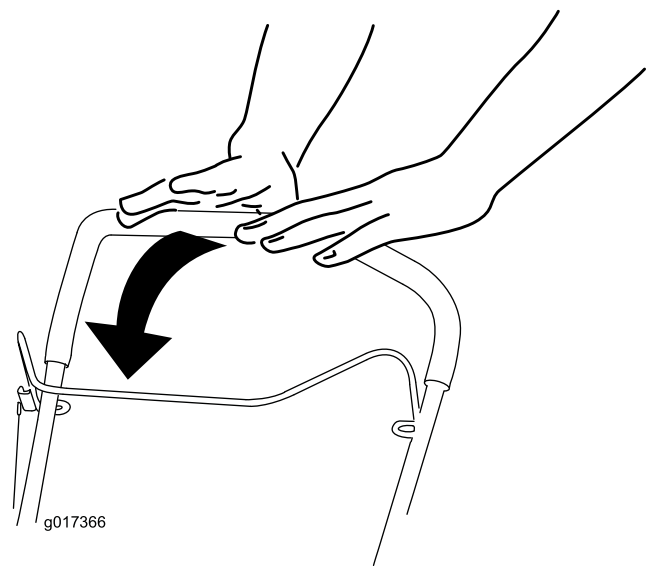

Figure 18

Stopping the Engine

Service Interval: Before each use or daily

To stop the engine, release the control bar (Figure 18).

Important: When you release the engine stop handle, both the engine and flexi blade should stop within 3 seconds. If they do not stop properly, stop using your machine immediately and contact an Authorized Service Dealer.

Operating Tips

General Cutting Tips

⚠ WARNING

Operating the machine on slopes of greater than 45° will cause severe engine damage due to a lack of lubrication. Some of the potential damage could include stuck valves, scored pistons, or burned crank bearings.

- **Before operating on any slope, complete a site survey to determine the actual slope where you will operate the machine.**
- **Do not operate the machine on slopes greater than 45°.**
- Clear the area of sticks, stones, wire, branches, and other debris that the flexi blade could hit.
- Avoid striking solid objects with the flexi blade. Never deliberately trim over any object.
- If the machine strikes an object or starts to vibrate, immediately stop the engine, disconnect the wire from the spark plug, and examine the machine for damage.
- For best performance, install a new flexi blade before the cutting season begins.
- Replace the flexi blade when necessary with a Toro replacement flexi blade.

Cutting Grass

- Cut only about a third of the grass blade at a time. Do not cut below the 30 mm (1.2 inch) setting (02602/02604) or 32 mm (1.25 inch) setting (02606) unless the grass is sparse or it is late fall when grass growth begins to slow down. Refer to Adjusting the Cutting Height.
- Cutting grass over 15 cm (6 inches) in length is **not** recommended. If the grass is too long, the machine may plug and cause the engine to stall.
- Cut only dry grass or leaves. Wet grass and leaves tend to clump on the yard and can cause the machine to plug or the engine to stall.

⚠ WARNING

Wet grass or leaves can cause serious injury if you slip and contact the flexi blade.

Trim only in dry conditions.

- Alternate the cutting direction. This helps disperse the clippings over the lawn for even fertilization.
- If the finished lawn appearance is unsatisfactory, try one or more of the following:

- Replace the flexi blade.
- Walk at a slower pace while cutting.
- Raise the cutting height on your machine.
- Cut the grass more frequently.
- Overlap cutting swaths instead of cutting a full swath with each pass.

Cutting Leaves

- After cutting the lawn, ensure that half of the lawn shows through the cut leaf cover. You may need to make more than one pass over the leaves.
- Slow down your cutting speed if the machine does not cut the leaves finely enough.

Maintenance

Note: Determine the left and right sides of the machine from the normal operating position.

Recommended Maintenance Schedule(s)

Maintenance Service Interval	Maintenance Procedure
After the first 5 hours	<ul style="list-style-type: none">• Change the engine oil.
Before each use or daily	<ul style="list-style-type: none">• Check the engine oil level.• Ensure that the engine stops within 3 seconds after releasing the control bar.• Clean grass clippings and dirt from the entire machine.
After each use	<ul style="list-style-type: none">• Clean grass clippings and dirt from the entire machine.
Every 100 hours	<ul style="list-style-type: none">• Check the spark plug and replace it if necessary.
Before storage	<ul style="list-style-type: none">• Empty the fuel tank before repairs as directed and before annual storage.• Clean the cooling system; remove grass clippings, debris, or dirt from the engine air cooling fins and starter. Clean the system more frequently in dirty or high-chaff conditions.
Yearly	<ul style="list-style-type: none">• Replace the air filter; replace it more frequently in dusty operating conditions.• Change the engine oil.• Replace the flexi blade.

Preparing for Maintenance

1. Stop the engine and wait for all moving parts to stop.
2. Disconnect the spark-plug wire from the spark plug ([Figure 19](#)) before performing any maintenance procedure.

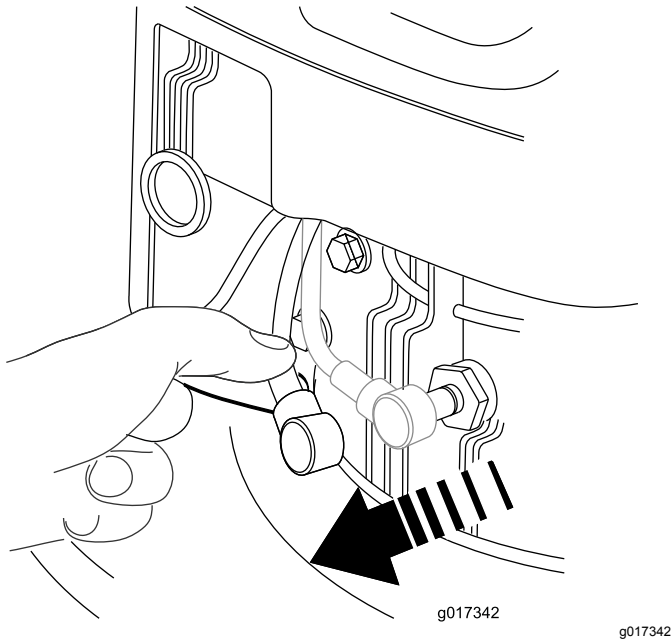

Figure 19

1. Spark plug wire

3. After performing the maintenance procedure(s), connect the spark plug wire to the spark plug.

⚠ WARNING

Tipping the machine may cause the fuel to leak. Gasoline is flammable, explosive and can cause personal injury.

Run the engine dry or remove the gasoline with a hand pump; never siphon.

Important: Always tip the machine onto its side with the dipstick down.

Replacing the Air Cleaner

Service Interval: Yearly

1. Press down on the latch tabs on top of the air cleaner cover ([Figure 20](#)).

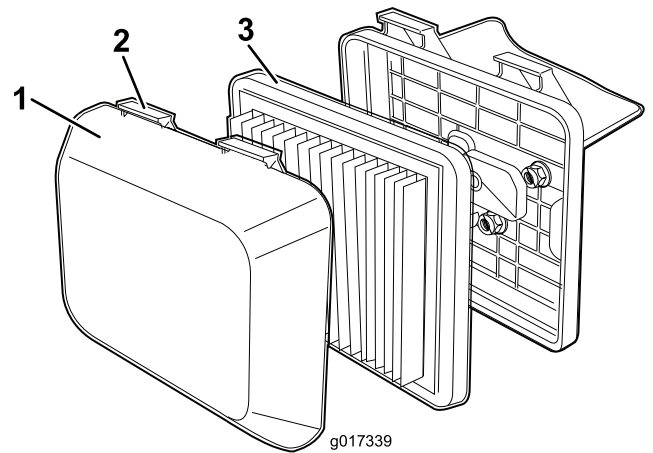

Figure 20

1. Cover
2. Latch tabs
3. Filter

2. Open the cover.
 3. Remove the filter ([Figure 20](#)).
 4. Inspect the filter, and replace it if it is damaged or excessively dirty.
 5. Inspect the paper air filter.
 - A. If the filter is damaged or is wet with oil or fuel, replace it.
 - B. If the filter is dirty, tap it on a hard surface several times or blow compressed air less than 207 kPa (30 psi) through the side of the filter that faces the engine.
- Note:** Do not brush the dirt off the filter; brushing forces dirt into the fibers.
6. Remove dirt from the air cleaner body and cover using a moist rag. **Do not wipe dirt into the air duct.**
 7. Insert the filter into the air cleaner.
 8. Install the cover.

Changing the Engine Oil

Service Interval: After the first 5 hours

Yearly

1. Ensure that the fuel tank contains little or no fuel so that fuel does not leak out when you tip the machine onto its side.
2. Run the engine a few minutes before changing the oil to warm it.

Note: Warm oil flows better and carries more contaminants.
3. Disconnect the wire from the spark plug. Refer to [Preparing for Maintenance \(page 15\)](#).
4. Remove the dipstick.

5. Tip the machine onto its side, with the dipstick down, to drain the used oil out through the oil fill tube.
6. Return the machine to the operating position.
7. **Slowly** pour oil into the oil fill hole, wait 3 minutes, and check the oil level on the dipstick by wiping the dipstick clean and then inserting, **but not screwing in**, the oil fill cap into the hole.

Note: Max. fill: 0.59 L (20 oz), type: Multigrade Mineral 10W-30 oil with an API service classification of SF, SG, SH, SJ, SL, or higher.

Note: Fill the engine crankcase with oil until the dipstick indicates that the engine oil level is correct as shown in (Figure 21). If you overfill the engine with oil, remove the excess oil as directed in 5.

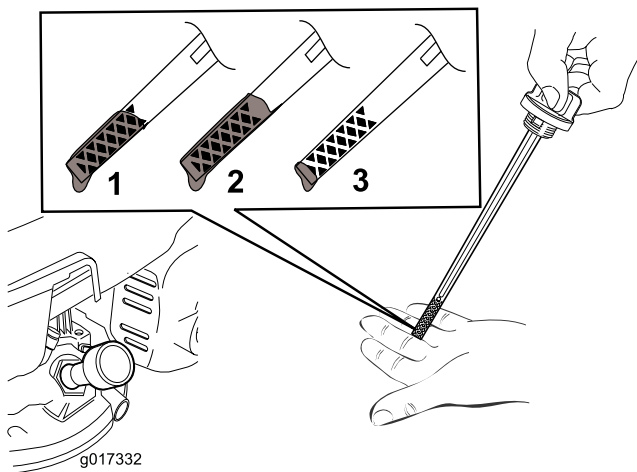

Figure 21

1. The oil level is at its maximum.
2. The oil level is too high—remove oil from the crankcase.
3. The oil level is too low—add oil to the crankcase.

8. Install the dipstick and hand tighten it securely.
9. Dispose of the used oil properly at a local recycling center.

Servicing the Spark Plug

Service Interval: Every 100 hours

Check the spark plug after every 100 operating hours. Use an **Champion RN9YC** spark plug or equivalent.

1. Stop the engine and wait for all moving parts to stop.
2. Disconnect the wire from the spark plug.
3. Clean around the spark plug.

4. Remove the spark plug from the cylinder head.

Important: Replace a cracked, fouled, or dirty spark plug. Do not clean the electrodes because grit entering the cylinder can damage the engine.
5. Set the gap on the plug to 0.76 mm (0.030 inch) (Figure 22).

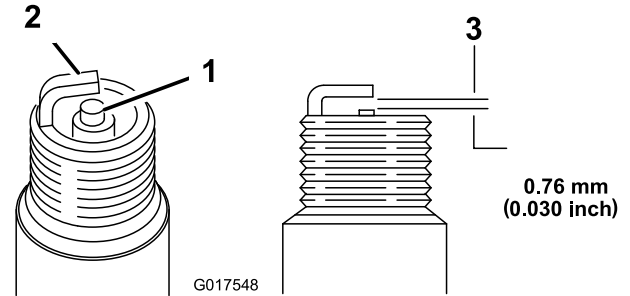

Figure 22

1. Center electrode insulator
2. Side electrode
3. Air gap (not to scale)

6. Install the spark plug and the gasket seal.
7. Torque the plug to 20 N-m (15 ft-lb).
8. Connect the wire to the spark plug.

Replacing the Flexi Blade

Service Interval: Yearly

Important: You will need a torque wrench to install the flexi blade assembly properly. If you do not have a torque wrench or are uncomfortable performing this procedure, contact an Authorized Service Dealer.

Examine the flexi blade assembly whenever you run out of gasoline. If the flexi blade assembly is damaged, replace it immediately.

1. Disconnect the spark plug wire from the spark plug. Refer to Preparing for Maintenance.
2. Tip the machine onto its side, with the air filter up.
3. Use a block of wood to hold the flexi blade steady.
4. Remove the flexi blade by turning the bolt counterclockwise (Figure 23), saving all the mounting hardware.

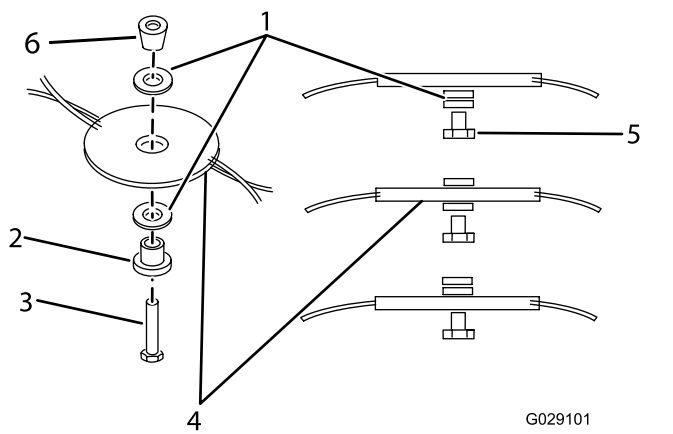

Figure 23

- | | |
|-------------|-----------------|
| 1. Spacers | 4. Flexi blade |
| 2. Retainer | 5. Retainer |
| 3. Bolt | 6. Large spacer |

5. Install the new flexi blade by turning the bolt clockwise (Figure 23), and install all the mounting hardware.
6. **Use a torque wrench to tighten the bolt to 25 N-m (18 ft-lb).**

Important: A bolt torqued to 25 N-m (18 ft-lb) is very tight. While holding the flexi blade with a block of wood, put your weight behind the ratchet or wrench and tighten the bolt securely. This bolt is very difficult to overtighten.

Cleaning the Machine

Service Interval: Before each use or daily

After each use

⚠ WARNING

The machine may dislodge material from under the machine housing.

- Wear eye protection.
- Stay in the operating position (behind the handle).
- Do not allow bystanders in the area.

1. Tip the machine on its side.
2. Use a brush or compressed air to remove grass and debris from the exhaust guard, the top cowl, and the surrounding deck areas.

Storage

Store the machine in a cool, clean, dry place.

Preparing the Machine for Storage

⚠ WARNING

Gasoline vapors can explode.

- Do not store gasoline more than 30 days.
- Do not store the machine in an enclosure near an open flame.
- Allow the engine to cool before storing it.

1. On the last refueling of the year, add fuel stabilizer to the fuel as directed by the engine manufacturer.
2. Run the machine until the engine stops from running out of fuel.
3. Prime the engine and start it again.
4. Allow the engine to run until it stops. When you can no longer start the engine, it is sufficiently dry.
5. Disconnect the wire from the spark plug.
6. Remove the spark plug, add 30 ml (1 oz) of oil through the spark plug hole, and pull the starter rope **slowly** several times to distribute oil throughout the cylinder to prevent cylinder corrosion during the off-season.
7. Install the spark plug and tighten it with a torque wrench to 20 N-m (15 ft-lb).
8. Tighten all nuts, bolts, and screws.

Troubleshooting

Problem	Possible Cause	Corrective Action
The engine does not start	<ol style="list-style-type: none"> 1. The wire is not connected to the spark plug. 2. The fuel cap vent hole is plugged. 3. The spark plug is pitted, fouled, or the gap is incorrect. 4. The fuel tank is empty or the fuel system contains stale fuel. 	<ol style="list-style-type: none"> 1. Connect the wire to the spark plug. 2. Clean the fuel cap vent hole or replace the fuel cap. 3. Check the spark plug and adjust the gap if necessary. Replace the spark plug if it is pitted, fouled, or cracked. 4. Drain and/or fill the fuel tank with fresh gasoline. If the problem persists, contact an Authorized Service Dealer.
The engine starts hard or loses power	<ol style="list-style-type: none"> 1. The fuel cap vent hole is plugged. 2. The air filter element is dirty and is restricting the air flow. 3. The underside of the machine housing contains clippings and debris. 4. The spark plug is pitted, fouled, or the gap is incorrect. 5. The engine oil level is too low, too high, or excessively dirty. 6. The fuel tank contains stale fuel. 	<ol style="list-style-type: none"> 1. Clean the fuel cap vent hole or replace the fuel cap. 2. Clean the air filter pre-cleaner and/or replace the paper air filter. 3. Clean under the machine housing. 4. Check the spark plug and adjust the gap if necessary. Replace the spark plug if it is pitted, fouled, or cracked. 5. Check the engine oil. Change the oil if it is dirty; add or drain the oil to adjust the oil level to the Full mark on the dipstick. 6. Drain and fill the fuel tank with fresh gasoline.
The engine runs rough	<ol style="list-style-type: none"> 1. The wire is not connected to the spark plug. 2. The spark plug is pitted, fouled, or the gap is incorrect. 3. The air filter element is dirty and is restricting the air flow. 	<ol style="list-style-type: none"> 1. Connect the wire to the spark plug. 2. Check the spark plug and adjust the gap if necessary. Replace the spark plug if it is pitted, fouled, or cracked. 3. Clean the air filter pre-cleaner and/or replace the paper air filter.
The machine or engine vibrates excessively	<ol style="list-style-type: none"> 1. The underside of the machine housing contains clippings and debris. 2. The engine mounting bolts are loose. 3. The mounting bolt is loose. 	<ol style="list-style-type: none"> 1. Clean under the machine housing. 2. Tighten the engine mounting bolts. 3. Tighten the mounting bolt.
There is an uneven cutting pattern	<ol style="list-style-type: none"> 1. You are cutting in the same pattern repeatedly. 2. The underside of the machine housing contains clippings and debris. 	<ol style="list-style-type: none"> 1. Change the cutting pattern. 2. Clean under the machine housing.

International Distributor List

Distributor:	Country:	Phone Number:	Distributor:	Country:	Phone Number:
Agrolanc Kft	Hungary	36 27 539 640	Maquiver S.A.	Colombia	57 1 236 4079
Balama Prima Engineering Equip.	Hong Kong	852 2155 2163	Maruyama Mfg. Co. Inc.	Japan	81 3 3252 2285
B-Ray Corporation	Korea	82 32 551 2076	Mountfield a.s.	Czech Republic	420 255 704 220
Casco Sales Company	Puerto Rico	787 788 8383	Mountfield a.s.	Slovakia	420 255 704 220
Ceres S.A.	Costa Rica	506 239 1138	Munditol S.A.	Argentina	54 11 4 821 9999
CSSC Turf Equipment (pvt) Ltd.	Sri Lanka	94 11 2746100	Norma Garden	Russia	7 495 411 61 20
Cyril Johnston & Co.	Northern Ireland	44 2890 813 121	Oslinger Turf Equipment SA	Ecuador	593 4 239 6970
Cyril Johnston & Co.	Republic of Ireland	44 2890 813 121	Oy Hako Ground and Garden Ab	Finland	358 987 00733
Equivar	Mexico	52 55 539 95444	Parkland Products Ltd.	New Zealand	64 3 34 93760
Femco S.A.	Guatemala	502 442 3277	Perfetto	Poland	48 61 8 208 416
ForGarder OU	Estonia	372 384 6060	Pratoverde SRL.	Italy	39 049 9128 128
G.Y.K. Company Ltd.	Japan	81 726 325 861	Prochaska & Cie	Austria	43 1 278 5100
Geomechaniki of Athens	Greece	30 10 935 0054	RT Cohen 2004 Ltd.	Israel	972 986 17979
Golf international Turizm	Turkey	90 216 336 5993	Riversa	Spain	34 9 52 83 7500
Guandong Golden Star	China	86 20 876 51338	Lely Turfcare	Denmark	45 66 109 200
Hako Ground and Garden	Sweden	46 35 10 0000	Solvret S.A.S.	France	33 1 30 81 77 00
Hako Ground and Garden	Norway	47 22 90 7760	Spypros Stavrinides Limited	Cyprus	357 22 434131
Hayter Limited (U.K.)	United Kingdom	44 1279 723 444	Surge Systems India Limited	India	91 1 292299901
Hydroturf Int. Co Dubai	United Arab Emirates	97 14 347 9479	T-Markt Logistics Ltd.	Hungary	36 26 525 500
Hydroturf Egypt LLC	Egypt	202 519 4308	Toro Australia	Australia	61 3 9580 7355
Irrimac	Portugal	351 21 238 8260	Toro Europe NV	Belgium	32 14 562 960
Irrigation Products Int'l Pvt Ltd.	India	0091 44 2449 4387	Valtech	Morocco	212 5 3766 3636
Jean Heybroek b.v.	Netherlands	31 30 639 4611	Victus Emak	Poland	48 61 823 8369

European Privacy Notice

The Information Toro Collects

Toro Warranty Company (Toro) respects your privacy. In order to process your warranty claim and contact you in the event of a product recall, we ask you to share certain personal information with us, either directly or through your local Toro company or dealer.

The Toro warranty system is hosted on servers located within the United States where privacy law may not provide the same protection as applies in your country.

BY SHARING YOUR PERSONAL INFORMATION WITH US, YOU ARE CONSENTING TO THE PROCESSING OF YOUR PERSONAL INFORMATION AS DESCRIBED IN THIS PRIVACY NOTICE.

The Way Toro Uses Information

Toro may use your personal information to process warranty claims, to contact you in the event of a product recall and for any other purpose which we tell you about. Toro may share your information with Toro's affiliates, dealers or other business partners in connection with any of these activities. We will not sell your personal information to any other company. We reserve the right to disclose personal information in order to comply with applicable laws and with requests by the appropriate authorities, to operate our systems properly or for our own protection or that of other users.

Retention of your Personal Information

We will keep your personal information as long as we need it for the purposes for which it was originally collected or for other legitimate purposes (such as regulatory compliance), or as required by applicable law.

Toro's Commitment to Security of Your Personal Information

We take reasonable precautions in order to protect the security of your personal information. We also take steps to maintain the accuracy and current status of personal information.

Access and Correction of your Personal Information

If you would like to review or correct your personal information, please contact us by email at legal@toro.com.

Australian Consumer Law

Australian customers will find details relating to the Australian Consumer Law either inside the box or at your local Toro Dealer.



Toro General Commercial Product Warranty

A Two-Year Limited Warranty

Conditions and Products Covered

The Toro Company and its affiliate, Toro Warranty Company, pursuant to an agreement between them, jointly warrant your Toro Commercial product ("Product") to be free from defects in materials or workmanship for two years or 1500 operational hours*, whichever occurs first. This warranty is applicable to all products with the exception of Aerators (refer to separate warranty statements for these products). Where a warrantable condition exists, we will repair the Product at no cost to you including diagnostics, labor, parts, and transportation. This warranty begins on the date the Product is delivered to the original retail purchaser.

* Product equipped with an hour meter.

Instructions for Obtaining Warranty Service

You are responsible for notifying the Commercial Products Distributor or Authorized Commercial Products Dealer from whom you purchased the Product as soon as you believe a warrantable condition exists. If you need help locating a Commercial Products Distributor or Authorized Dealer, or if you have questions regarding your warranty rights or responsibilities, you may contact us at:

Toro Commercial Products Service Department
Toro Warranty Company
8111 Lyndale Avenue South
Bloomington, MN 55420-1196
952-888-8801 or 800-952-2740
E-mail: commercial.warranty@toro.com

Owner Responsibilities

As the Product owner, you are responsible for required maintenance and adjustments stated in your *Operator's Manual*. Failure to perform required maintenance and adjustments can be grounds for disallowing a warranty claim.

Items and Conditions Not Covered

Not all product failures or malfunctions that occur during the warranty period are defects in materials or workmanship. This warranty does not cover the following:

- Product failures which result from the use of non-Toro replacement parts, or from installation and use of add-on, or modified non-Toro branded accessories and products. A separate warranty may be provided by the manufacturer of these items.
- Product failures which result from failure to perform recommended maintenance and/or adjustments. Failure to properly maintain your Toro product per the Recommended Maintenance listed in the *Operator's Manual* can result in claims for warranty being denied.
- Product failures which result from operating the Product in an abusive, negligent, or reckless manner.
- Parts subject to consumption through use unless found to be defective. Examples of parts which are consumed, or used up, during normal Product operation include, but are not limited to, brake pads and linings, clutch linings, blades, reels, rollers and bearings (sealed or greasable), bed knives, spark plugs, castor wheels and bearings, tires, filters, belts, and certain sprayer components such as diaphragms, nozzles, and check valves, etc.
- Failures caused by outside influence. Conditions considered to be outside influence include, but are not limited to, weather, storage practices, contamination, use of unapproved fuels, coolants, lubricants, additives, fertilizers, water, or chemicals, etc.
- Failure or performance issues due to the use of fuels (e.g. gasoline, diesel, or biodiesel) that do not conform to their respective industry standards.

Countries Other than the United States or Canada

Customers who have purchased Toro products exported from the United States or Canada should contact their Toro Distributor (Dealer) to obtain guarantee policies for your country, province, or state. If for any reason you are dissatisfied with your Distributor's service or have difficulty obtaining guarantee information, contact the Toro importer.

- Normal noise, vibration, wear and tear, and deterioration.
- Normal "wear and tear" includes, but is not limited to, damage to seats due to wear or abrasion, worn painted surfaces, scratched decals or windows, etc.

Parts

Parts scheduled for replacement as required maintenance are warranted for the period of time up to the scheduled replacement time for that part. Parts replaced under this warranty are covered for the duration of the original product warranty and become the property of Toro. Toro will make the final decision whether to repair any existing part or assembly or replace it. Toro may use remanufactured parts for warranty repairs.

Deep Cycle and Lithium-Ion Battery Warranty:

Deep cycle and Lithium-Ion batteries have a specified total number of kilowatt-hours they can deliver during their lifetime. Operating, recharging, and maintenance techniques can extend or reduce total battery life. As the batteries in this product are consumed, the amount of useful work between charging intervals will slowly decrease until the battery is completely worn out. Replacement of worn out batteries, due to normal consumption, is the responsibility of the product owner. Battery replacement may be required during the normal product warranty period at owner's expense. Note: (Lithium-Ion battery only): A Lithium-Ion battery has a part only prorated warranty beginning year 3 through year 5 based on the time in service and kilowatt hours used. Refer to the *Operator's Manual* for additional information.

Maintenance is at Owner's Expense

Engine tune-up, lubrication, cleaning and polishing, replacement of filters, coolant, and completing recommended maintenance are some of the normal services Toro products require that are at the owner's expense.

General Conditions

Repair by an Authorized Toro Distributor or Dealer is your sole remedy under this warranty.

Neither The Toro Company nor Toro Warranty Company is liable for indirect, incidental or consequential damages in connection with the use of the Toro Products covered by this warranty, including any cost or expense of providing substitute equipment or service during reasonable periods of malfunction or non-use pending completion of repairs under this warranty. Except for the Emissions warranty referenced below, if applicable, there is no other express warranty. All implied warranties of merchantability and fitness for use are limited to the duration of this express warranty.

Some states do not allow exclusions of incidental or consequential damages, or limitations on how long an implied warranty lasts, so the above exclusions and limitations may not apply to you. This warranty gives you specific legal rights, and you may also have other rights which vary from state to state.

Note regarding engine warranty:

The Emissions Control System on your Product may be covered by a separate warranty meeting requirements established by the U.S. Environmental Protection Agency (EPA) and/or the California Air Resources Board (CARB). The hour limitations set forth above do not apply to the Emissions Control System Warranty. Refer to the Engine Emission Control Warranty Statement supplied with your product or contained in the engine manufacturer's documentation for details