



**Count on it.**

**Parts Catalog**

**Super Recycler®**

**Lawn Mower**

Model No. 20382—Serial No. 315000001 and Up



# Ordering Replacement Parts

To order replacement parts, please supply the part number, the quantity, and the description of each part desired.

## Understanding Reference Numbers

Each identified part in an illustration has a reference number. The reference number for a part also appears in the parts list, along with other information about the part.

This catalog uses two special reference number formats, one to indicate parts in a service assembly and another to indicate the quantity of a given part in an illustration.

## Service Assembly Reference Numbers

Parts in service assemblies have reference numbers in the form a:b. The a represents the reference number of the entire service assembly and the b represents a sequential number unique to each part within the service assembly.

For example, a wheel assembly might be identified by reference number 6, the tire by 6:1, the valve by 6:2, and the wheel by 6:3. When you order the assembly identified by reference number 6, you receive all parts identified by reference numbers 6:1, 6:2, and 6:3. However, you may also order any part individually. Reference numbers of this type appear in illustration and in parts lists.

## Reference Numbers Indicating Quantity

In an illustration, if a reference number indicates more than one part, the reference number has the form nX y. The n represents the quantity of the part, the X is the multiplication symbol, and the y represents the reference number.

For example, in an illustration, the reference number 2X 37 means that two of the parts identified by reference number 37 are indicated.

# Contents

Housing Assembly .....	4
Housing Assembly No. 115-2854 .....	6
Rear Door and Mulch Plug Assembly .....	8
Bag Assembly .....	10
Engine and Blade Assembly .....	12
Front Wheel and Height-of-Cut Assembly .....	14
Rear Wheel and Height-of-Cut Assembly .....	16
Handle Assembly .....	18
Attachments and Accessories .....	20

# Housing Assembly

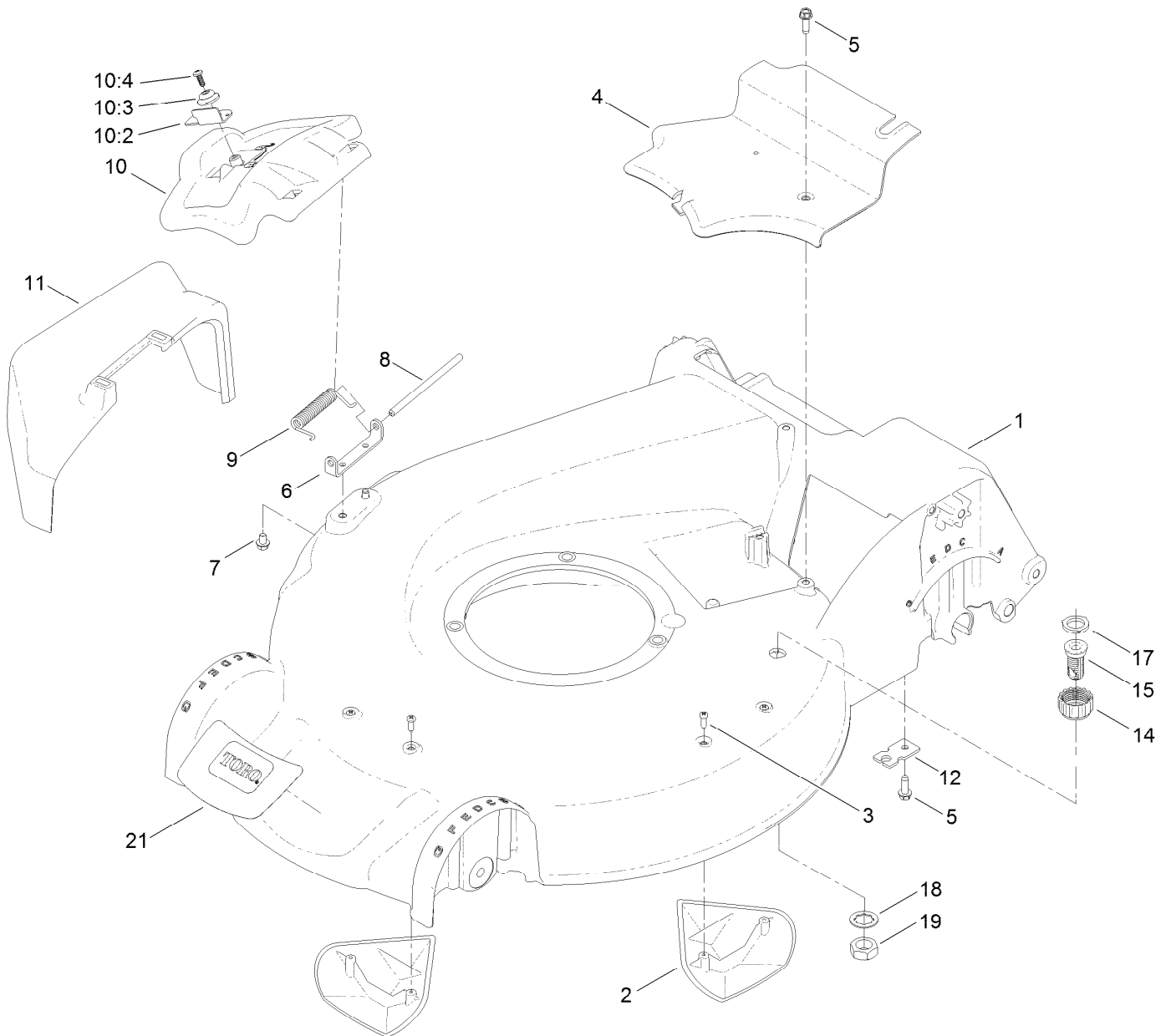

## Housing Assembly (continued)

<i>Ref.</i>	<i>Part Number</i>	<i>Qty.</i>	<i>Description</i>	<i>Ref.</i>	<i>Part Number</i>	<i>Qty.</i>	<i>Description</i>
1	115-2854	1	Housing ASM	10:3	107-7456	1	Cap-Door
2	108-3798	2	Kicker-Housing	10:4	107-7461	1	Screw-Plastite
3	32144-111	4	Screw-PPH	11	108-3753	1	Chute-Discharge, Side
4	107-7494	1	Cover-Belt	12	107-7497	1	Bracket-Cable, Traction
5	49-2040	2	Screw-HWHTF	14	112-6401	1	Coupling-Hose, Washout Port
6	112-6416	1	Bracket-Cover	15	112-6400	1	Port-Washout
7	99-8445	2	Screw-HWH	17	112-6438	1	Washer-Seal, Washout Port
8	99-5291	1	Rod-Cover	18	3254-5	1	Washer-Tooth, Internal
9	99-5293	1	Spring-Torsion	19	3218-6	1	Nut-Jam
10	107-3717	1	Discharge Door ASM	21	121-5758	1	Decal-Deck
10:2	107-0795	1	Latch-Door				

# Housing Assembly No. 115-2854

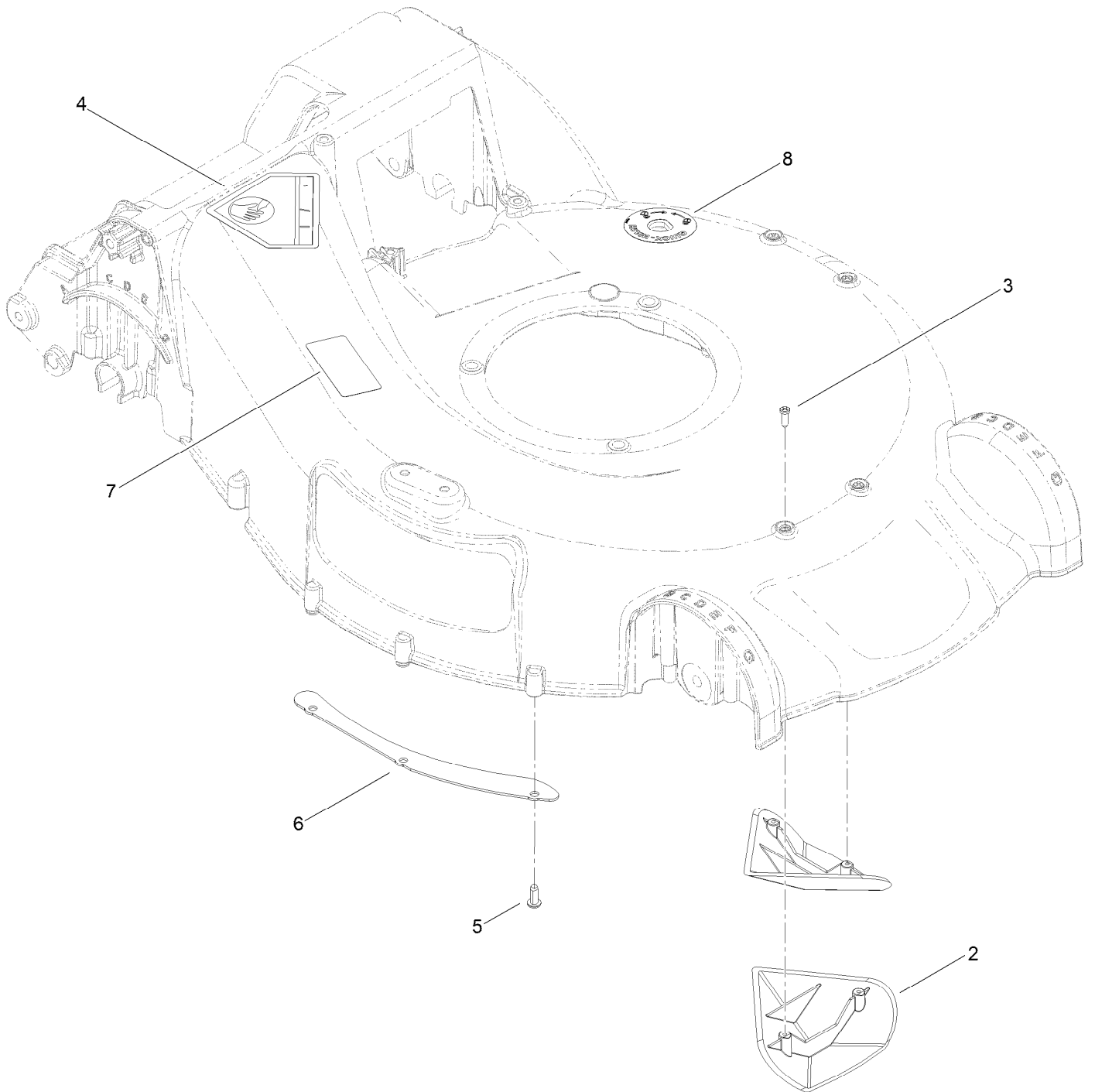

# Housing Assembly No. 115-2854 (continued)

<i>Ref.</i>	<i>Part Number</i>	<i>Qty.</i>	<i>Description</i>
2	108-3798	2	Kicker-Housing
3	32144-111	4	Screw-PPH
4	94-8072	1	Decal-Danger
5	63-8590	3	Screw

<i>Ref.</i>	<i>Part Number</i>	<i>Qty.</i>	<i>Description</i>
6	105-1316-03	1	Sheet-Lip
7	125-5092	1	Decal-Placement, Foot
8	112-8867	1	Decal-Port, Washout

# Rear Door and Mulch Plug Assembly

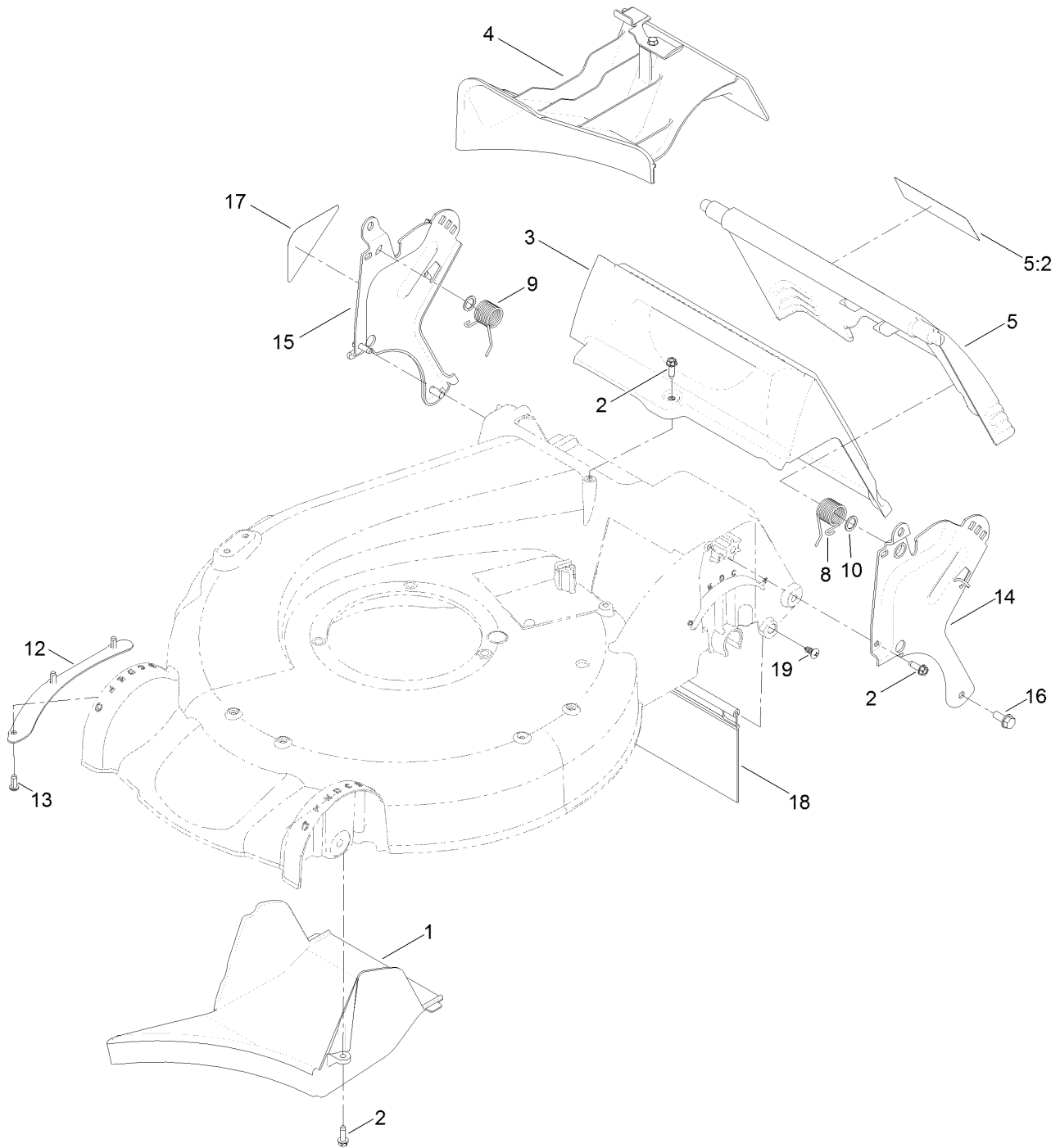



## Rear Door and Mulch Plug Assembly (continued)

<i>Ref.</i>	<i>Part Number</i>	<i>Qty.</i>	<i>Description</i>	<i>Ref.</i>	<i>Part Number</i>	<i>Qty.</i>	<i>Description</i>
1	107-7495	1	Tunnel-Discharge	12	105-1316-03	1	Sheet-Lip
2	49-2040	5	Screw-HWHTF	13	63-8590	3	Screw
3	114-2668	1	Chute	14	114-2671-03	1	Bracket-Handle, LH
4	115-8413	1	Mulch Plug ASM	15	114-2672-03	1	Bracket-Handle, RH
5	121-5776	1	Rear Door ASM	16	32144-11	2	Screw-HWHTF
5:2	131-4514	1	Decal-Warning	17	115-2884	1	Decal-Instruction
8	115-2859	1	Spring-Torsion	18	120-7011	1	Shield-Trailing
9	114-7924	1	Spring-Torsion	19	117-1092	2	Screw-PTH
10	94-8196	2	Washer-Nylon				

# Bag Assembly

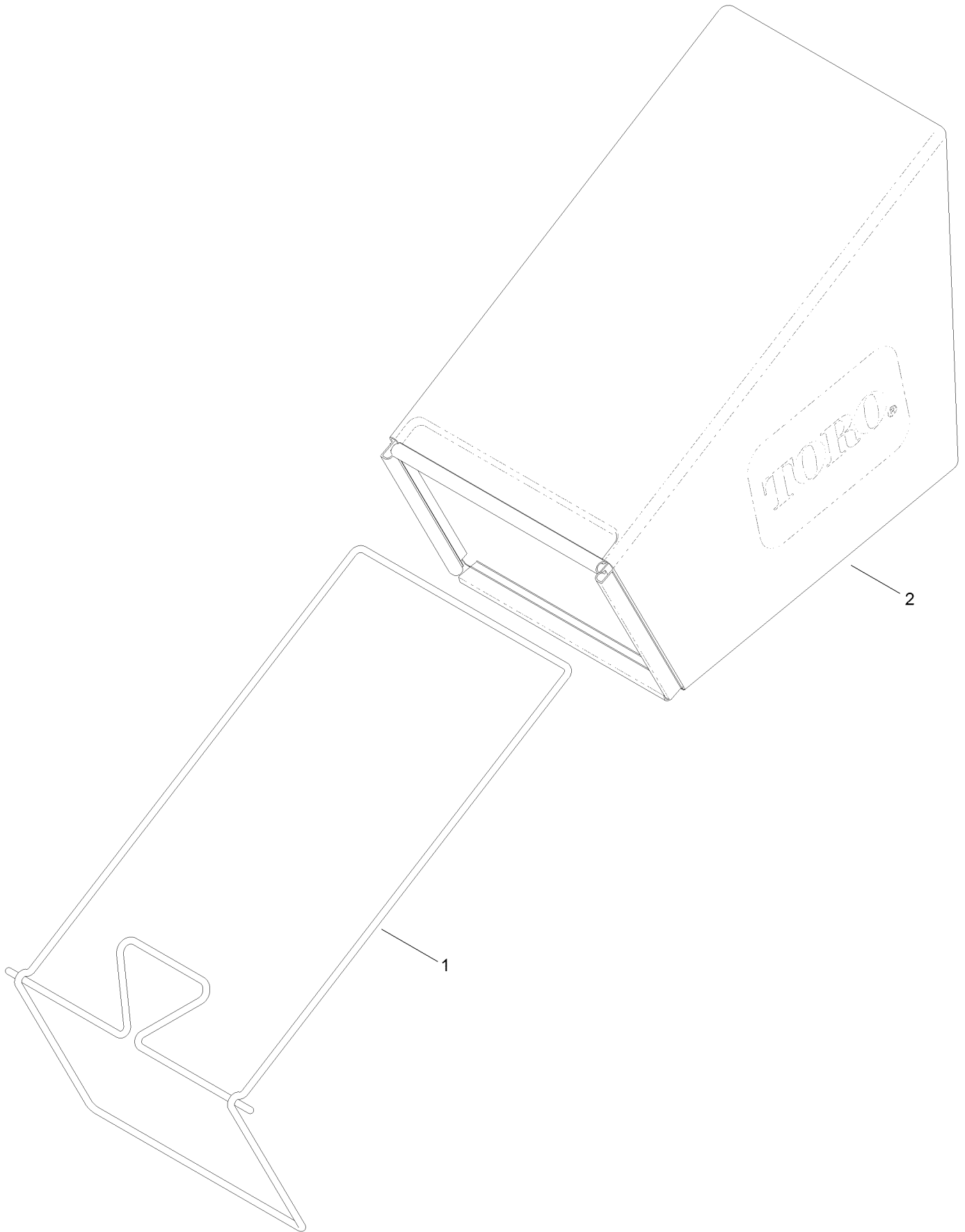

## Bag Assembly (continued)

<i>Ref.</i>	<i>Part Number</i>	<i>Qty.</i>	<i>Description</i>
1	121-2333-03	1	Frame-Bag
2	114-2664	1	Grass Bag ASM

# Engine and Blade Assembly

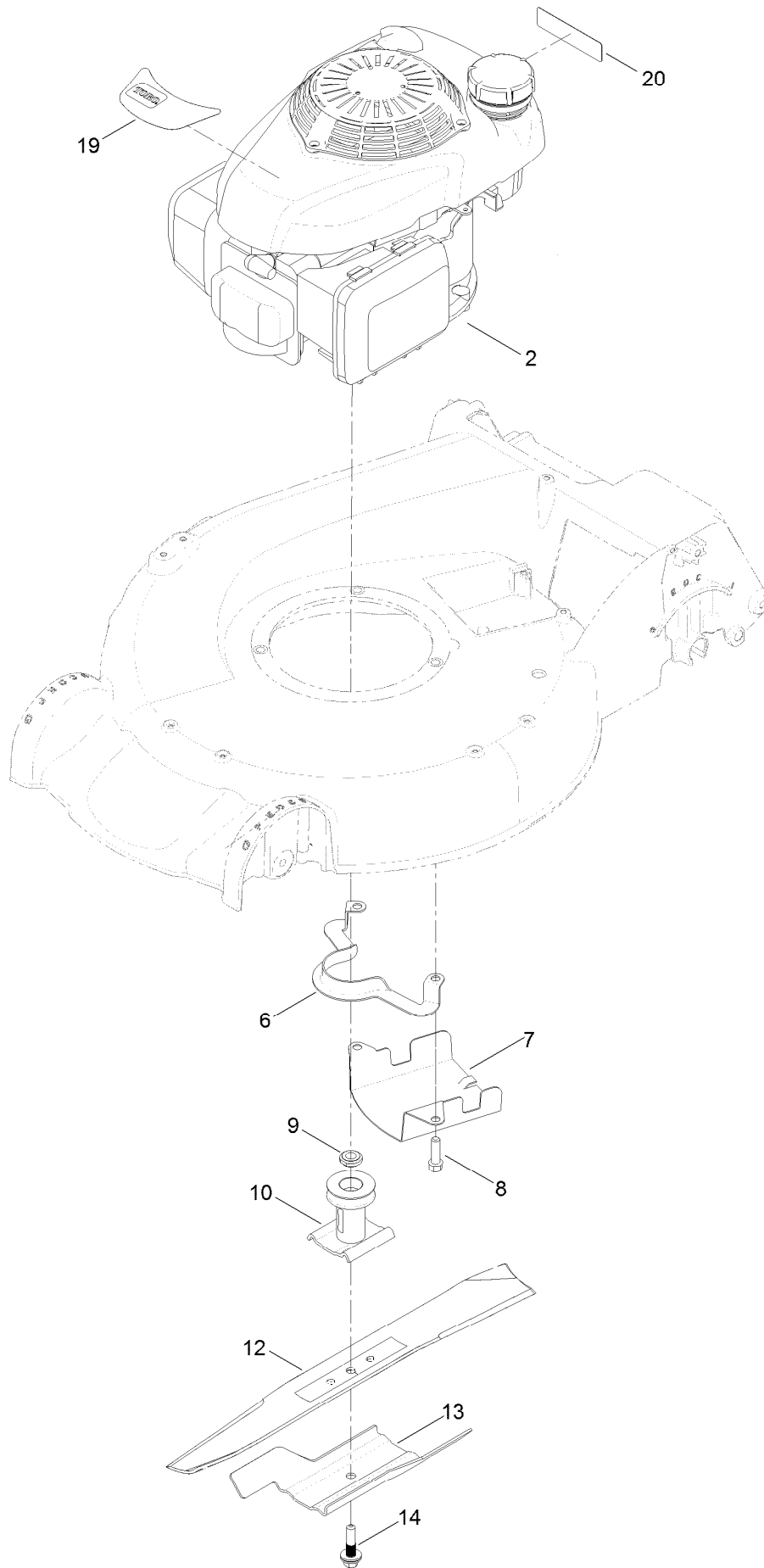

## Engine and Blade Assembly (continued)

<i>Ref.</i>	<i>Part Number</i>	<i>Qty.</i>	<i>Description</i>	<i>Ref.</i>	<i>Part Number</i>	<i>Qty.</i>	<i>Description</i>
2		1	Engine-Honda, Gcv160La0 S3B ●■	10	114-2774	1	Driver-Blade
6	108-8110-03	1	Guide-Belt	12	108-3762-03	1	Blade-Recycling
7	107-7489-03	1	Shield-Grass	13	105-6848-03	1	Accelerator-Blade
8	95-1727	3	Screw-Taptite	14	117-5270	1	Bolt-Blade
9	106-3999	1	Spacer-Driver	19	131-0854	1	Decal-Shroud, Honda
				20	117-2718	1	Decal-Arrester, Spark

● Not serviced separately

■ Obtain parts from [www.honda-engines.com](http://www.honda-engines.com)

# Front Wheel and Height-of-Cut Assembly

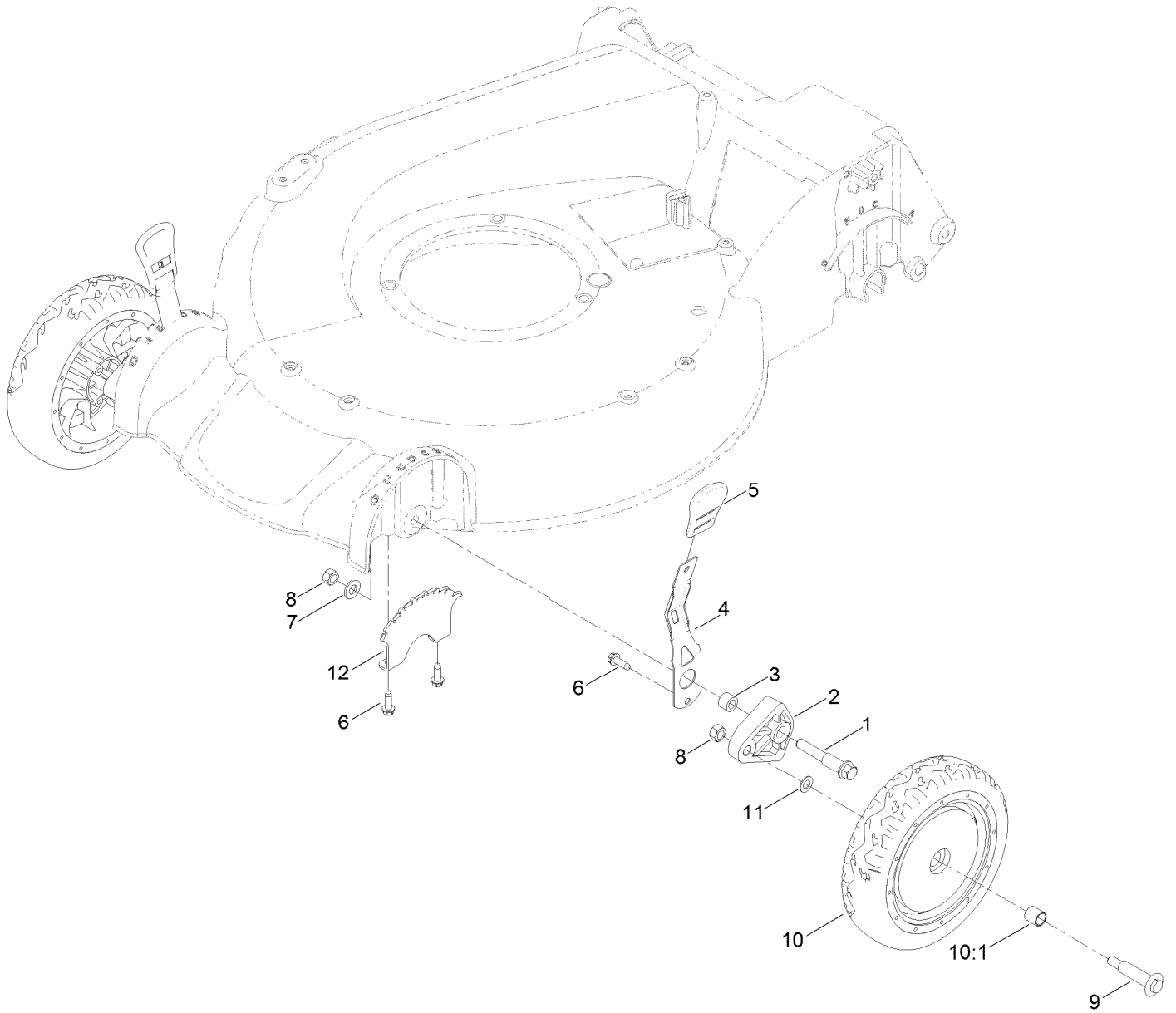

## Front Wheel and Height-of-Cut Assembly (continued)

<i>Ref.</i>	<i>Part Number</i>	<i>Qty.</i>	<i>Description</i>	<i>Ref.</i>	<i>Part Number</i>	<i>Qty.</i>	<i>Description</i>
1	114-3467	2	Screw-Shoulder	8	125-5069	4	Nut-Hex
2	107-7492	2	Arm-Pivot	9	92-1057	2	Bolt-Shoulder
3	52-2480	2	Spacer-Wheel	10	107-3708	2	Wheel ASM
4	107-7491	2	Arm-Spring	10:1	27-6250	2	Bushing
5	110-0549	2	Knob-HOC	11	40-1940	2	Washer
6	49-2040	6	Screw-HWHTF	12	107-7478	2	Plate-HOC
7	3256-24	2	Washer-Flat				

# Rear Wheel and Height-of-Cut Assembly

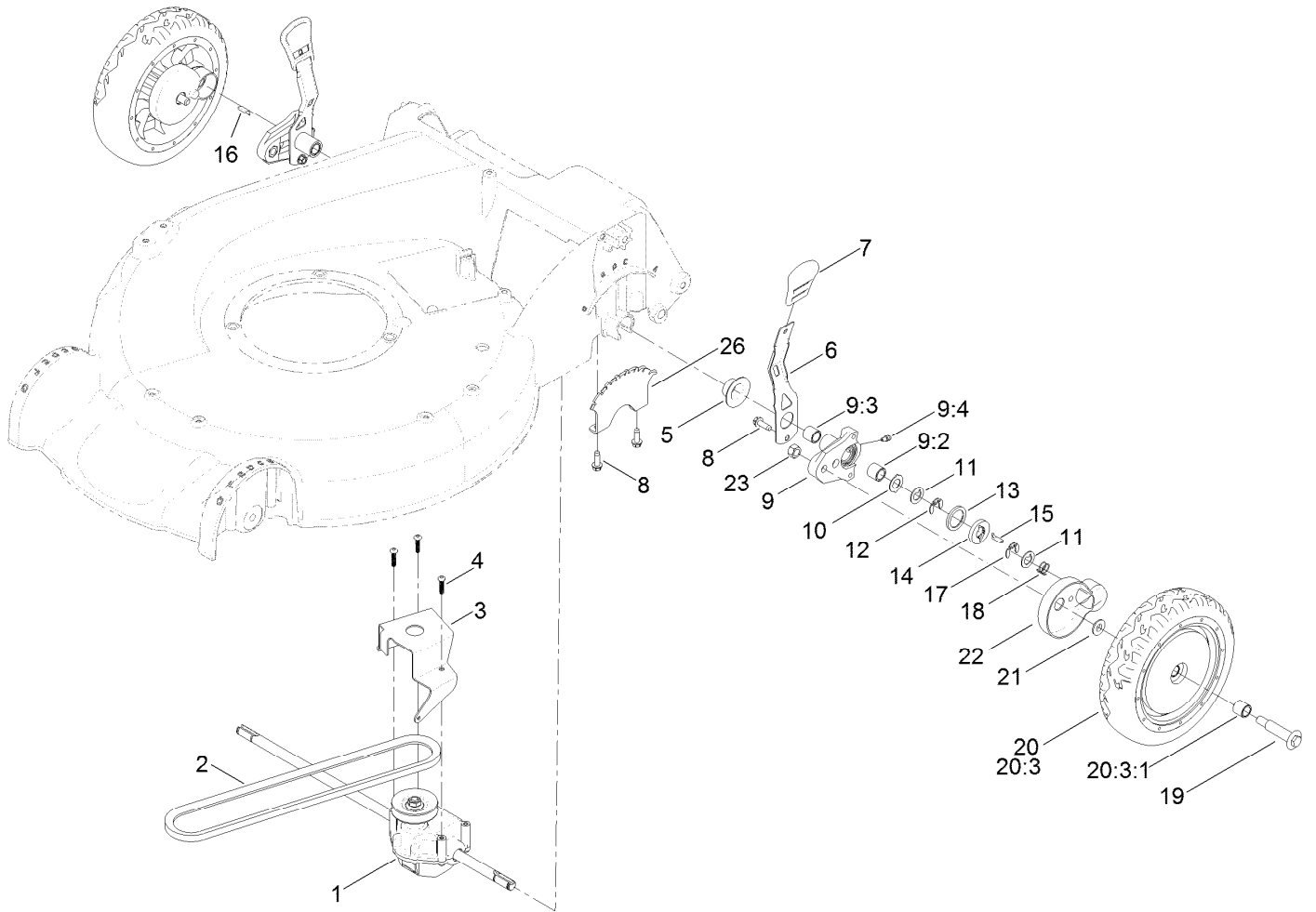



## Rear Wheel and Height-of-Cut Assembly (continued)

<i>Ref.</i>	<i>Part Number</i>	<i>Qty.</i>	<i>Description</i>	<i>Ref.</i>	<i>Part Number</i>	<i>Qty.</i>	<i>Description</i>
1	121-9184	1	Transmission ASM	13	65-4710	2	Ring-Friction
2	92-1043	1	V-Belt	14	65-4760	2	Washer-Clutch
3	114-7977-03	1	Bracket-Transmission	15	66-6050	1	Key-Rocking, LH
4	108-7476	3	Screw-Plastite	16	66-6040	1	Key-Rocking, RH
5	42-3520	2	Cap-End	17	65-4750	2	Gear-Pinion
6	107-7491	2	Arm-Spring	18	65-4720	2	Spring-Compression
7	110-0549	2	Knob-HOC	19	92-1057	2	Bolt-Shoulder
8	49-2040	6	Screw-HWHTF	20	107-3709	2	Wheel Gear ASM
9	100-8774	2	Pivot Arm ASM	20:3		1	Wheel ASM ●
9:2	47-2900	1	Bushing	20:3:1	27-6250	2	Bushing
9:3	70-9760	1	Bushing	21	74-1671	2	Spacer-Cover, Wheel
9:4	302-56	1	Fitting-Grease	22	74-1660	2	Cover-Wheel
10	65-4730	2	Washer-Arm, Pivot	23	125-5069	2	Nut-Hex
11	65-4740	4	Washer-Thrust, Keyed	26	107-7478	2	Plate-HOC
12	65-2720	4	Ring-Clip, Locking				

● Not serviced separately

# Handle Assembly

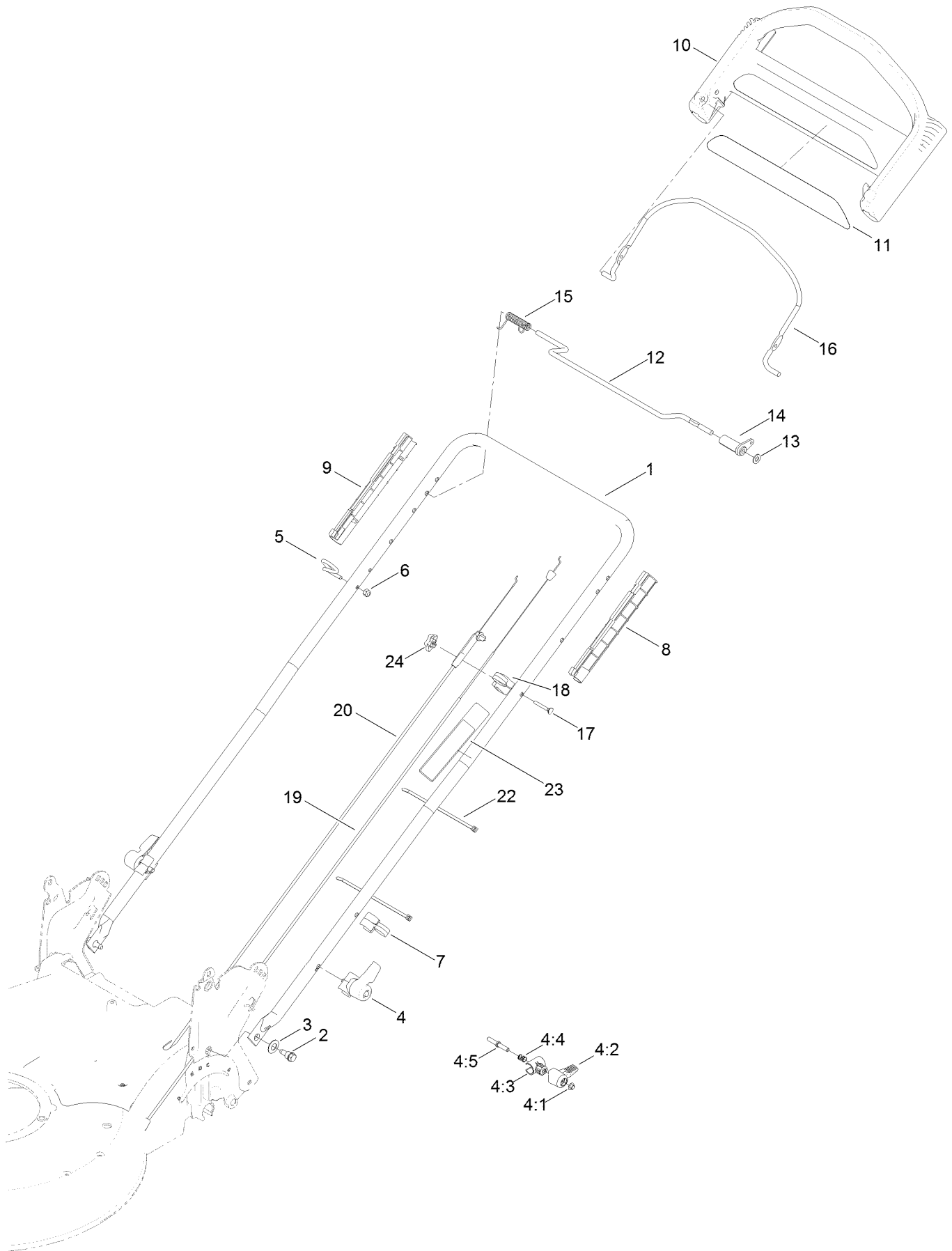

## Handle Assembly (continued)

<i>Ref.</i>	<i>Part Number</i>	<i>Qty.</i>	<i>Description</i>	<i>Ref.</i>	<i>Part Number</i>	<i>Qty.</i>	<i>Description</i>
1	121-9167-05	1	Handle	10	104-8678	1	Handle-Control
2	115-1958	2	Bolt-Shoulder	11	117-1019	1	Decal
3	112-9972	2	Washer-Spring, Conical	12	99-1588	1	Bar-Control, Traction
4	115-2860	2	Quick Release ASM	13	3256-23	1	Washer-Plain
4:1	109-0917	1	Nut-Push	14	99-1589	1	Lever-Traction
4:2	114-7995	1	Lever	15	121-9118	1	Spring-Torsion
4:3	114-7996	1	Anchor-Spring	16	104-8679-03	1	Bail-Brake
4:4	115-2858	1	Spring-Compression	17	95-4453	1	Screw
4:5	114-2675	1	Rod-Release	18	99-5239	1	Anchor-Cable
5	86-9671	1	Guide-Rope	19	108-8158	1	Cable-Traction
6	3296-73	1	Nut-Lock, NI	20	120-3921	1	Cable-Brake
7	114-7988	1	Guide-Cable	22	614249	3	Tie-Cable
8	105-6842	1	Guide-LH	23	131-0894	1	Decal-Traction, Adjust
9	105-6841	1	Guide-RH	24	131-0897	1	Knob-Handle, Locking

# Attachments and Accessories

## For 20382 Super Recycler Lawn Mower

<b>Product Name</b>	<b>Model/Part</b>
Bagging Blade .....	108-3759-03
Traction Assist Handle Kit.....	108-8120
WPM Maintenance Kit, 2014 and Newer .....	130-8134
Lawnmower Cover.....	490-7462

**Notes:**

**Notes:**

**Notes:**



**Count on it.**