



**Count on it.**

**Parts Catalog**

**22in Recycler®**

**Lawn Mower**

Model No. 20374—Serial No. 314000001 and Up



# Ordering Replacement Parts

To order replacement parts, please supply the part number, the quantity, and the description of each part desired.

## Understanding Reference Numbers

Each identified part in an illustration has a reference number. The reference number for a part also appears in the parts list, along with other information about the part.

This catalog uses two special reference number formats, one to indicate parts in a service assembly and another to indicate the quantity of a given part in an illustration.

## Service Assembly Reference Numbers

Parts in service assemblies have reference numbers in the form a:b. The a represents the reference number of the entire service assembly and the b represents a sequential number unique to each part within the service assembly.

For example, a wheel assembly might be identified by reference number 6, the tire by 6:1, the valve by 6:2, and the wheel by 6:3. When you order the assembly identified by reference number 6, you receive all parts identified by reference numbers 6:1, 6:2, and 6:3. However, you may also order any part individually. Reference numbers of this type appear in illustration and in parts lists.

## Reference Numbers Indicating Quantity

In an illustration, if a reference number indicates more than one part, the reference number has the form nX y. The n represents the quantity of the part, the X is the multiplication symbol, and the y represents the reference number.

For example, in an illustration, the reference number 2X 37 means that two of the parts identified by reference number 37 are indicated.

# Contents

Deck, Side Chute and Rear Door Assembly .....	4
Rear Bag Assembly .....	6
Engine and Blade Assembly .....	8
Shroud, Flywheel and Fuel Tank Assembly .....	10
Dipstick, Brake and Governor Arm Assembly .....	12
Carburetor, Muffler, Air Cleaner and Valve Cover Assembly .....	14
Front Wheel and Height-of-Cut Assembly .....	16
Transmission and Rear Wheel Drive Assembly .....	18
Handle Assembly .....	20
Electrical Assembly .....	22
Attachments and Accessories .....	24

# Deck, Side Chute and Rear Door Assembly

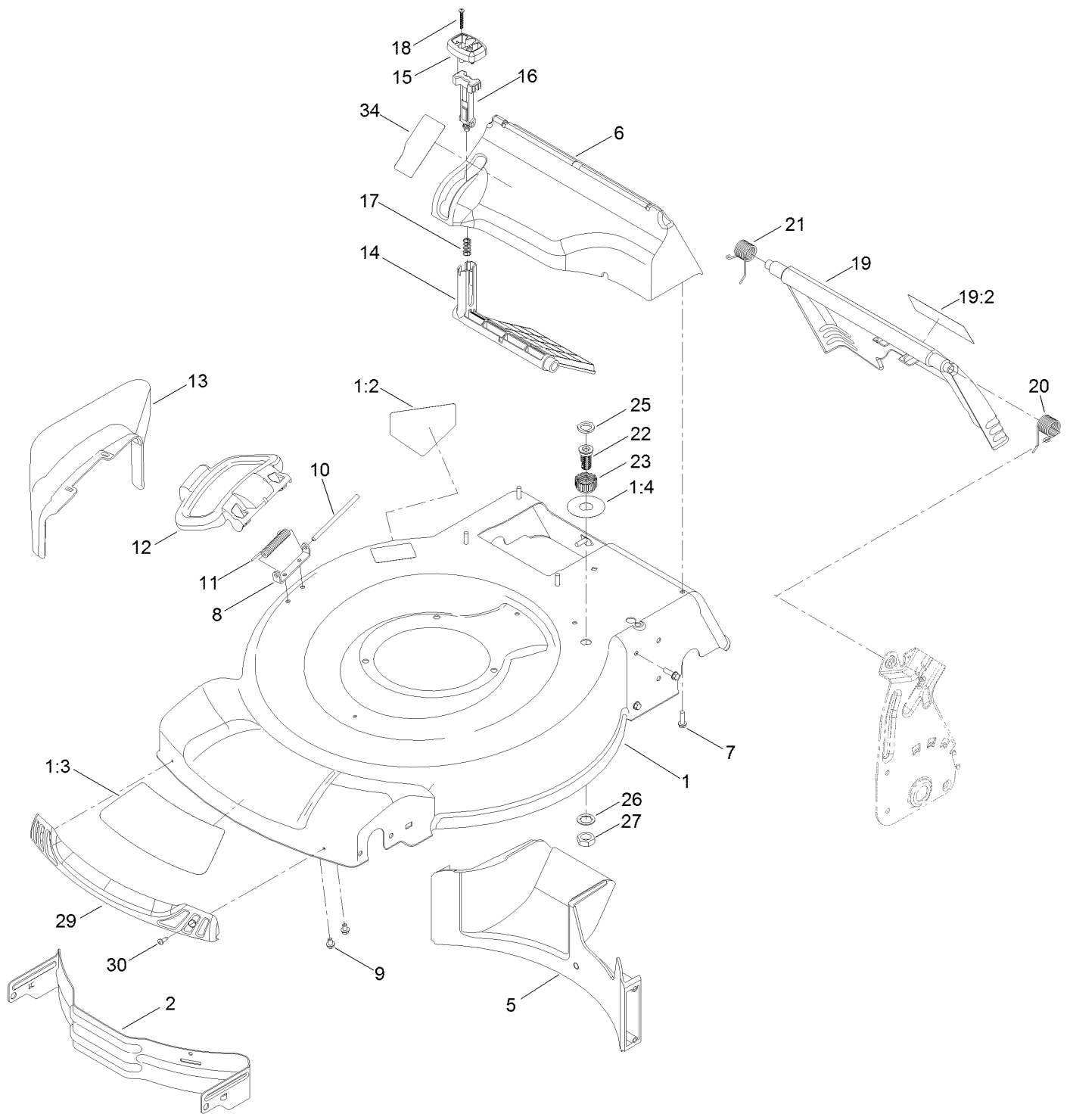

## Deck, Side Chute and Rear Door Assembly (continued)

<i>Ref.</i>	<i>Part Number</i>	<i>Qty.</i>	<i>Description</i>	<i>Ref.</i>	<i>Part Number</i>	<i>Qty.</i>	<i>Description</i>
1	130-2389	1	Housing ASM	16	114-7959	1	Latch-Recycle
1:2	94-8072	1	Decal-Danger	17	117-1031	1	Spring-Compression
1:3	115-4676	1	Decal-Recycler	18	32104-120	2	Screw-PPH
1:4	112-8867	1	Decal-Port, Washout	19	121-5776	1	Rear Door ASM
2	114-7963-01	1	Baffle-Front	19:2	114-7982	1	Decal-Warning
5	114-7961	1	Baffle-Rear	20	115-2859	1	Spring-Torsion
6	114-7957	1	Chute-Recycle	21	114-7924	1	Spring-Torsion
7	46-8091	9	Screw-HWH	22	112-6400	1	Port-Washout
8	112-6416	1	Bracket-Cover	23	112-6401	1	Coupling-Hose, Washout Port
9	99-8445	2	Screw-HWH	25	112-6438	1	Washer-Seal, Washout Port
10	99-5291	1	Rod-Cover	26	3254-5	1	Washer-Tooth, Internal
11	99-5293	1	Spring-Torsion	27	3218-6	1	Nut-Jam
12	115-8449	1	Deflector-Side	29	114-7987	1	Bumper
13	115-8447	1	Chute-Discharge, Side	30	105-6849	2	Screw-Forming, Thread
14	114-7960	1	Deflector-Recycle	34	125-5026	1	Decal
15	114-7958	1	Knob-Recycle				

# Rear Bag Assembly

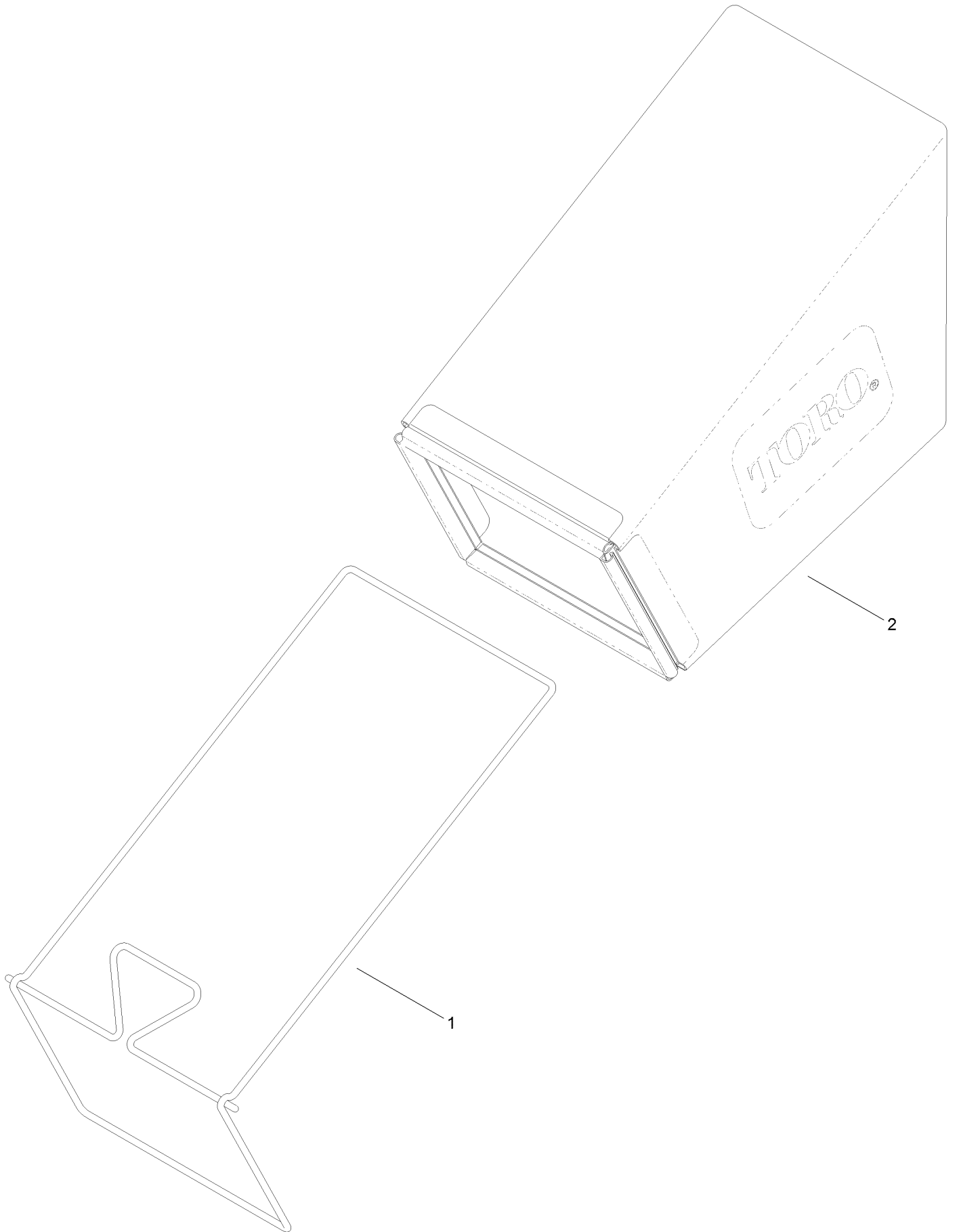

## Rear Bag Assembly (continued)

<i>Ref.</i>	<i>Part Number</i>	<i>Qty.</i>	<i>Description</i>
1	114-2679-03	1	Frame-Bag
2	115-4673	1	Grass Bag ASM

# Engine and Blade Assembly

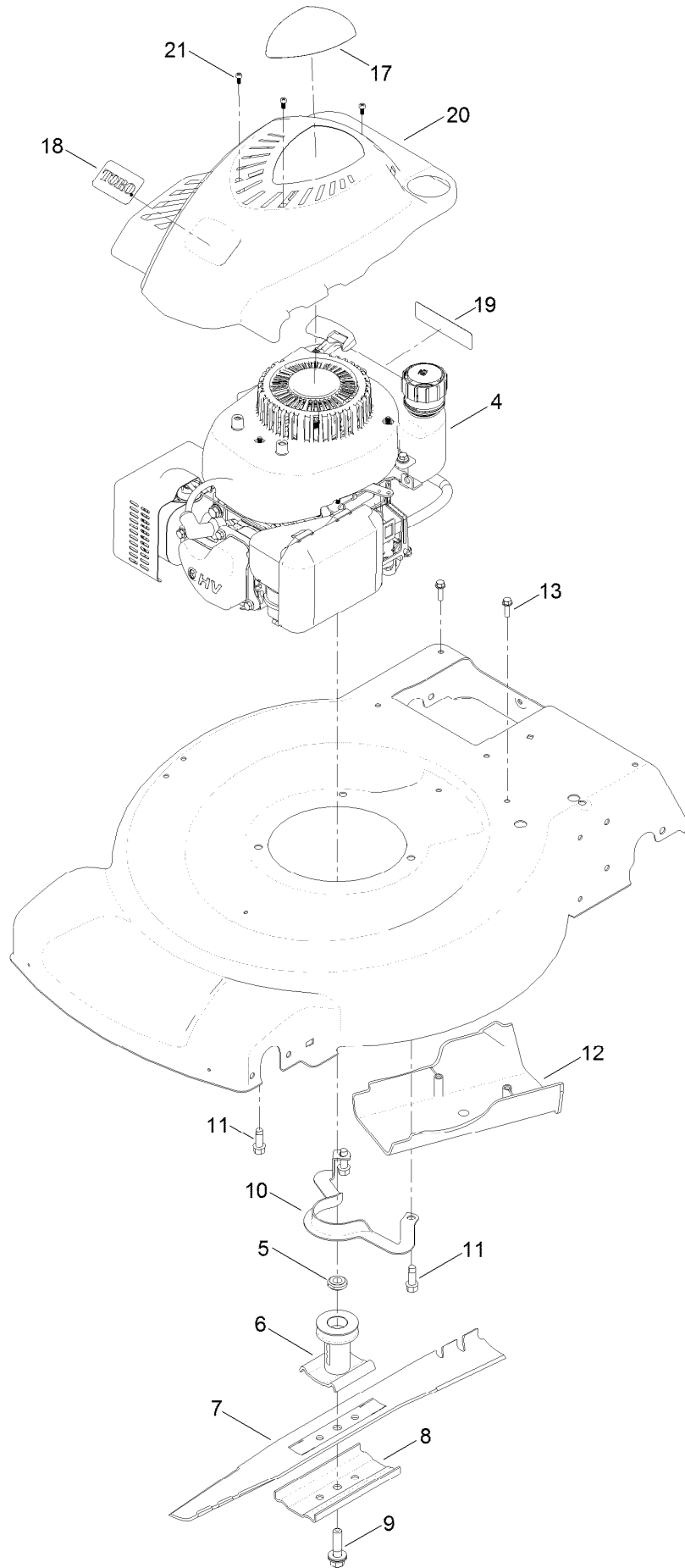



## Engine and Blade Assembly (continued)

<i>Ref.</i>	<i>Part Number</i>	<i>Qty.</i>	<i>Description</i>	<i>Ref.</i>	<i>Part Number</i>	<i>Qty.</i>	<i>Description</i>
4	120-4413	1	Engine-1P65Fc	12	114-7937	1	Cover-Belt
5	106-3999	1	Spacer-Driver	13	46-8091	2	Screw-HWH
6	106-3987	1	Driver-Blade	17	130-2360	1	Decal-Shroud
7	108-9764-03	1	Blade-22 Inch	18	125-2505	1	Decal
8	108-3766-03	1	Support-Blade	19	117-2718	1	Decal-Arrester, Spark
9	125-2466	1	Bolt-Blade	20	121-0443	1	Shroud
10	105-3030-03	1	Guide-Belt	21	121-4155	3	Screw-PPH
11	95-1726	3	Screw-Taptite				

# Shroud, Flywheel and Fuel Tank Assembly

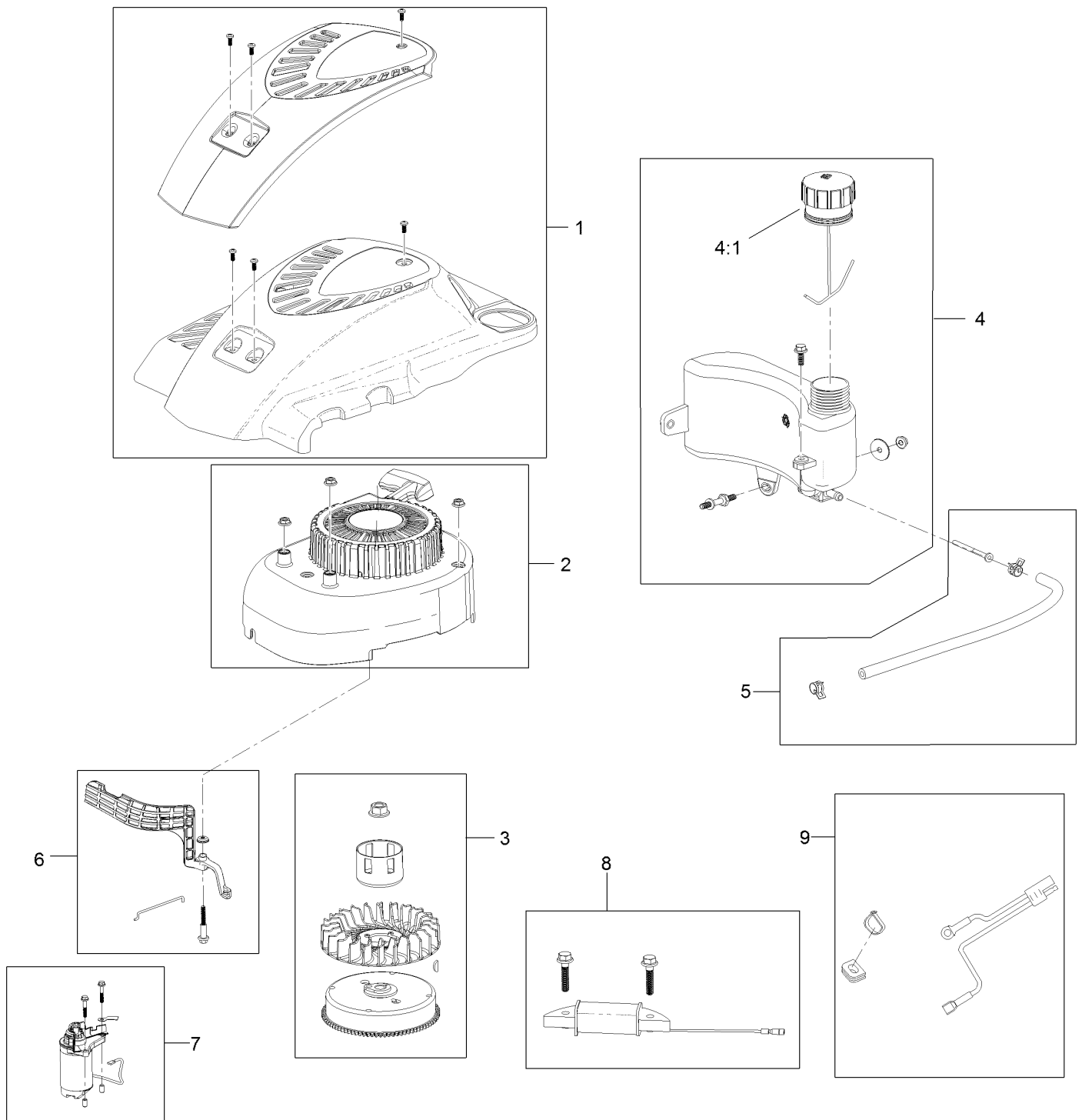

## Shroud, Flywheel and Fuel Tank Assembly (continued)

<i>Ref.</i>	<i>Part Number</i>	<i>Qty.</i>	<i>Description</i>	<i>Ref.</i>	<i>Part Number</i>	<i>Qty.</i>	<i>Description</i>
1	119-1990	1	Shroud ASM	5	121-4167	1	Fuel Line Kit
2	121-4160	1	Recoil And Blower Shroud Kit	6	121-4168	1	Air Vane Kit
3	121-0391	1	Flywheel And Fan Kit	7	121-0393	1	Starter Kit
4	121-4162	1	Fuel Tank Kit	8	121-0392	1	Alternator Kit
4:1	121-4163	1	Cap-Fuel	9	121-0395	1	Wire Harness Kit

# Dipstick, Brake and Governor Arm Assembly

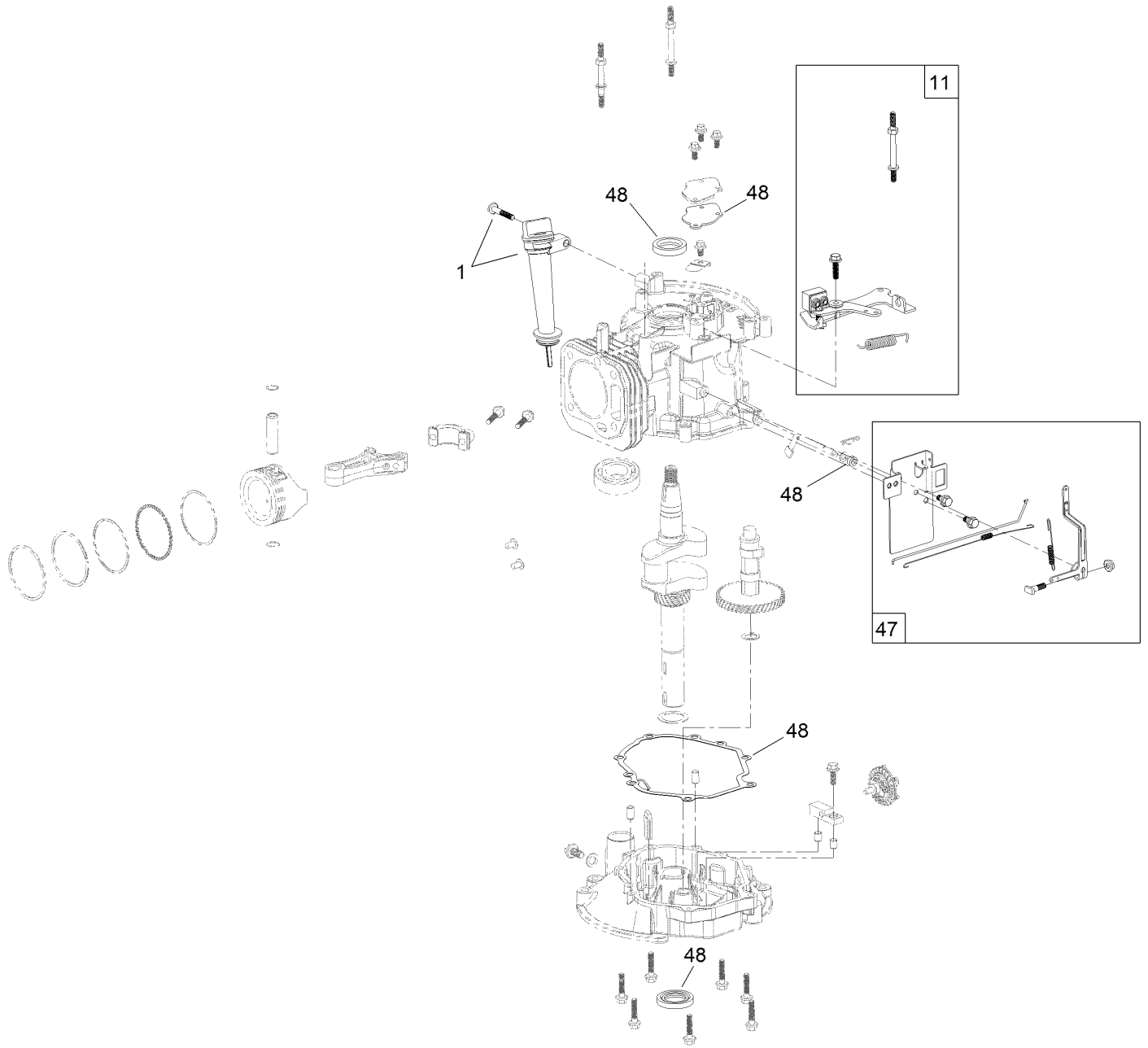

# Dipstick, Brake and Governor Arm Assembly (continued)

<i>Ref.</i>	<i>Part Number</i>	<i>Qty.</i>	<i>Description</i>
1	121-4279	1	Dipstick And Fill Tube Kit
11	121-4205	1	Brake Kit

<i>Ref.</i>	<i>Part Number</i>	<i>Qty.</i>	<i>Description</i>
47	119-1968	1	Governor Arm Kit
48	127-9144	1	Seal And Gasket Kit

# Carburetor, Muffler, Air Cleaner and Valve Cover Assembly

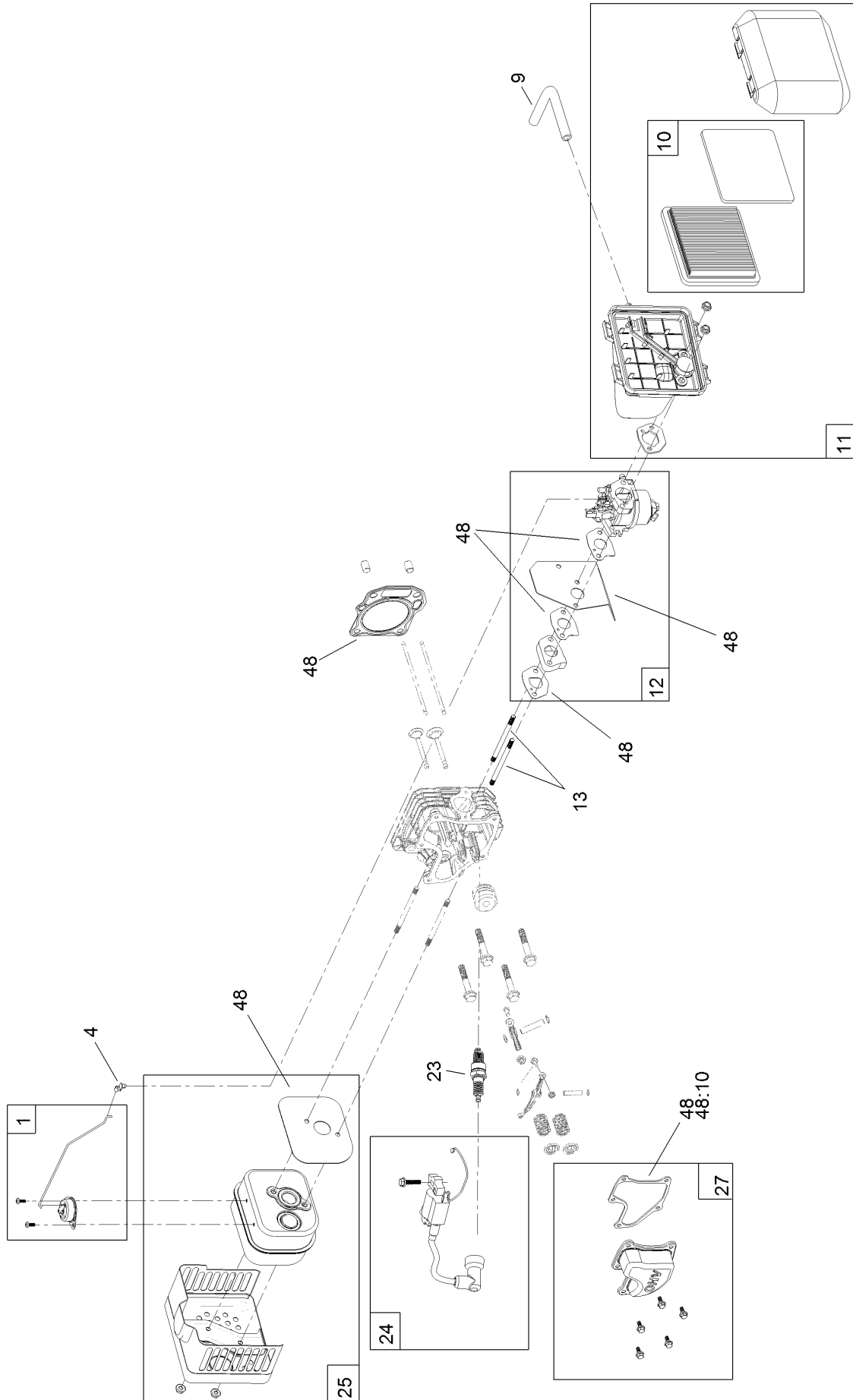

## Carburetor, Muffler, Air Cleaner and Valve Cover Assembly (continued)

<i>Ref.</i>	<i>Part Number</i>	<i>Qty.</i>	<i>Description</i>	<i>Ref.</i>	<i>Part Number</i>	<i>Qty.</i>	<i>Description</i>
1	121-4175	1	Thermal Control Kit	13	121-0367	2	Stud-Intake
4	120-4451	1	Lock-Throttle	23	121-4199	1	Spark Plug
9	119-1902	1	Tube-Breather	24	121-4186	1	Ignition Kit
10	119-1909	1	Air Filter And Prefilter Kit	25	121-4277	1	Muffler And Shield Kit
11	121-4177	1	Air Cleaner ASM Kit	27	121-4188	1	Valve Cover Kit
12	120-4405	1	Carburetor Repair Kit	48	127-9144	1	Seal And Gasket Kit
12	121-4181	1	Carburetor Complete Kit	48:10	121-4190	1	Gasket-Valve Cover

# Front Wheel and Height-of-Cut Assembly

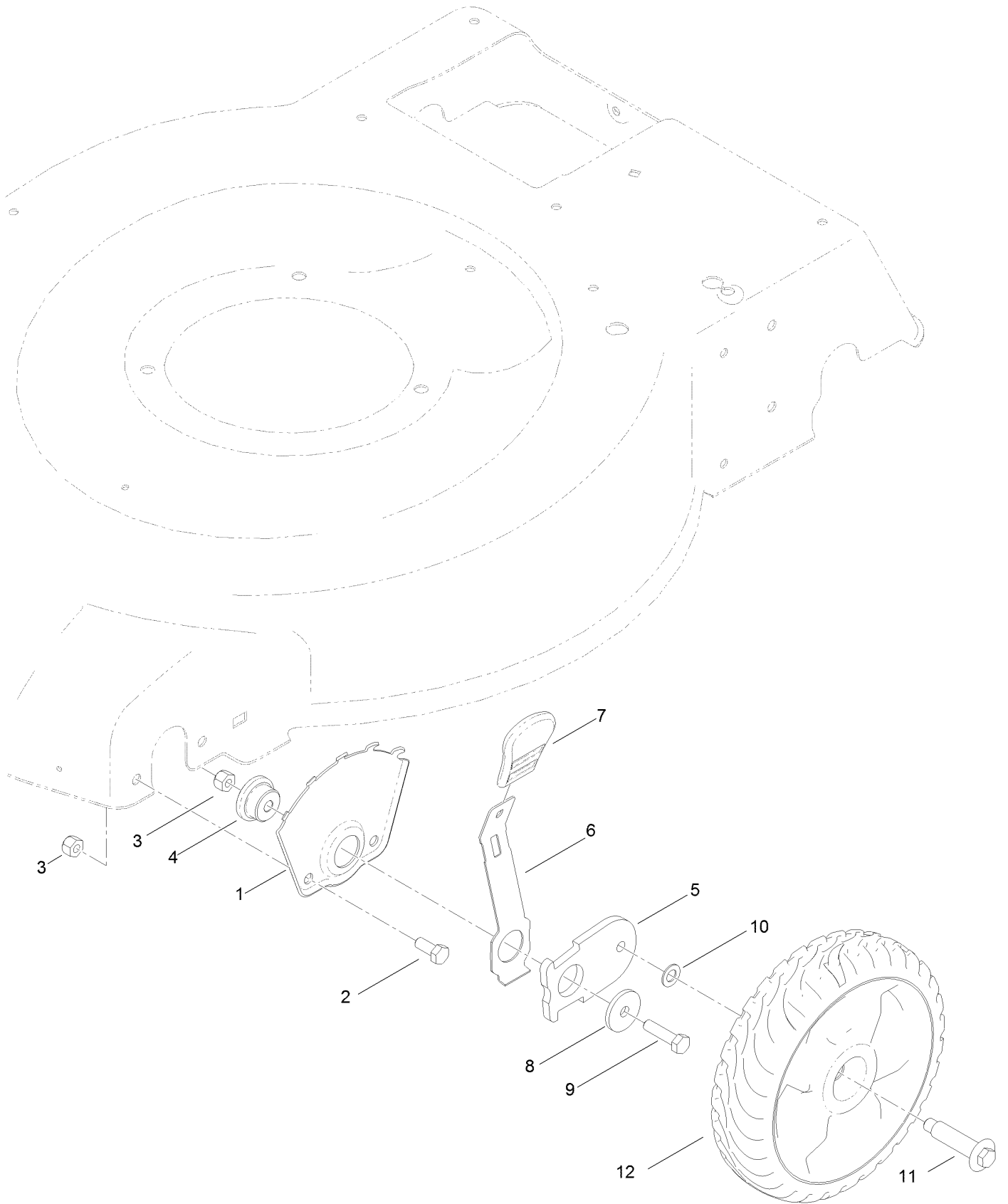



## Front Wheel and Height-of-Cut Assembly (continued)

<i>Ref.</i>	<i>Part Number</i>	<i>Qty.</i>	<i>Description</i>	<i>Ref.</i>	<i>Part Number</i>	<i>Qty.</i>	<i>Description</i>
1	115-1956-03	2	Plate-HOC, Front	7	110-0549	2	Knob-HOC
2	322-3	4	Screw-HH	8	105-3048	2	Washer-Flat
3	3296-29	6	Nut-Lock, NI	9	322-6	2	Screw-HH
4	105-1818	2	Bushing-Mount, HOC	10	40-1940	2	Washer
5	105-1807	2	Arm-Pivot, Front	11	614650	2	Bolt-Shoulder
6	105-1809	2	Arm-Spring	12	115-2894	2	8 Inch Wheel ASM

# Transmission and Rear Wheel Drive Assembly

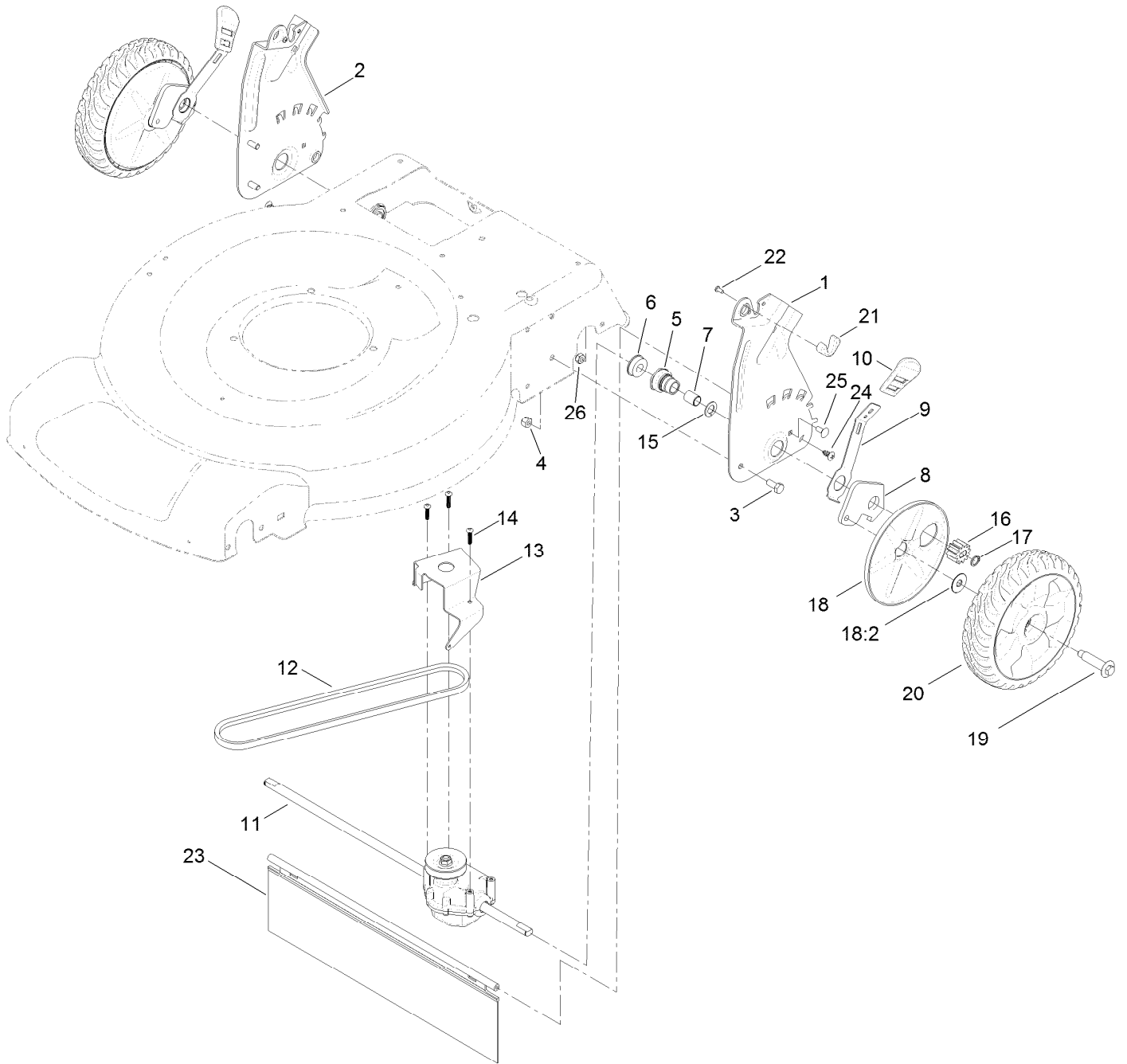

## Transmission and Rear Wheel Drive Assembly (continued)

<i>Ref.</i>	<i>Part Number</i>	<i>Qty.</i>	<i>Description</i>	<i>Ref.</i>	<i>Part Number</i>	<i>Qty.</i>	<i>Description</i>
1	127-6877-03	1	Plate-Rear, LH (HOC)	15	110-7191	2	Washer-Thrust
2	127-6878-03	1	Plate-Rear, RH (HOC)	16	110-9417	2	Gear-Pinion, 15T
3	322-3	4	Screw-HH	17	32151-61	2	Ring-Retaining
4	3296-29	4	Nut-Lock, NI	18	110-1792	2	Wheel Cover ASM
5	108-9779	2	Retainer-Bushing, HOC	18:2	614426	1	Washer-Stepped
6	104-8699	2	Bearing-Ball	19	614650	2	Bolt-Shoulder
7	108-9782	2	Bushing-Sleeve	20	119-3822	2	8 Inch Wheel Gear ASM
8	108-9781	2	Arm-Pivot, Rear	21	115-8406	2	Anchor-Bag
9	108-9780	2	Arm-Spring	22	105-9437	2	Screw-PPH
10	110-0549	2	Knob-HOC	23	120-7012	1	Shield-Trailing
11	121-9178	1	Transmission ASM	24	117-1092	2	Screw-PTH
12	115-4669	1	Belt-V	25	3229-11	2	Screw-CARR
13	114-7977-03	1	Bracket-Transmission	26	3296-16	2	Nut-Lock, NI
14	108-7476	3	Screw-Plastite				

# Handle Assembly

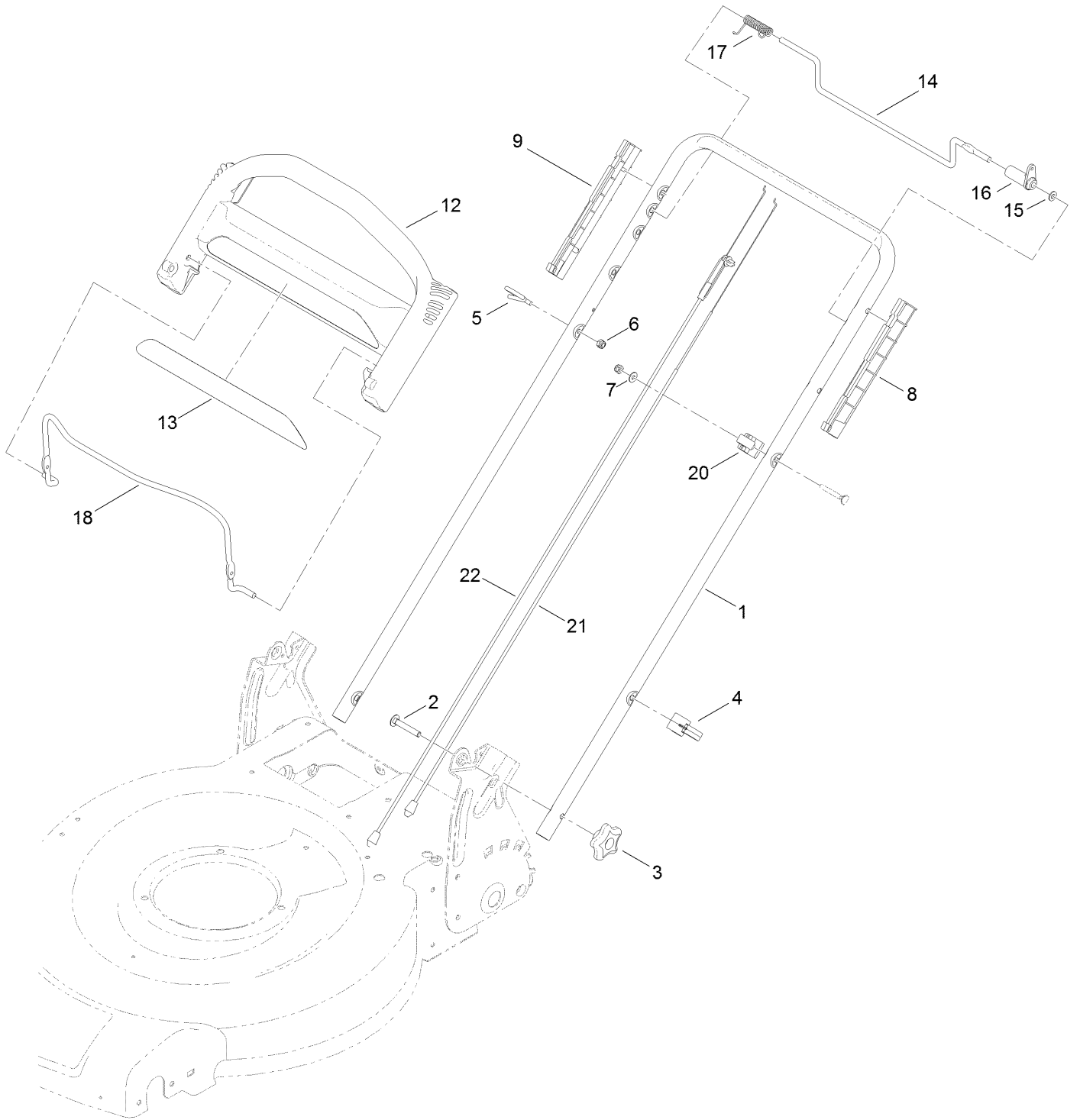

## Handle Assembly (continued)

<i>Ref.</i>	<i>Part Number</i>	<i>Qty.</i>	<i>Description</i>	<i>Ref.</i>	<i>Part Number</i>	<i>Qty.</i>	<i>Description</i>
1	119-3810-05	1	Handle	13	117-1019	1	Decal
2	3230-6	2	Screw-CARR	14	99-1588	1	Bar-Control, Traction
3	117-5976	2	Knob-Handle	15	3256-23	1	Washer-Plain
4	114-7988	1	Guide-Cable	16	99-1589	1	Lever-Traction
5	86-9671	1	Guide-Rope	17	121-9118	1	Spring-Torsion
6	3296-73	2	Nut-Lock, NI	18	104-8679-03	1	Bail-Brake
7	3256-1	1	Washer-Flat	20	99-5239	1	Anchor-Cable
8	105-6842	1	Guide-LH	21	115-8435	1	Cable-Traction
9	105-6841	1	Guide-RH	22	115-8437	1	Cable-Brake
12	104-8678	1	Handle-Control				

# Electrical Assembly

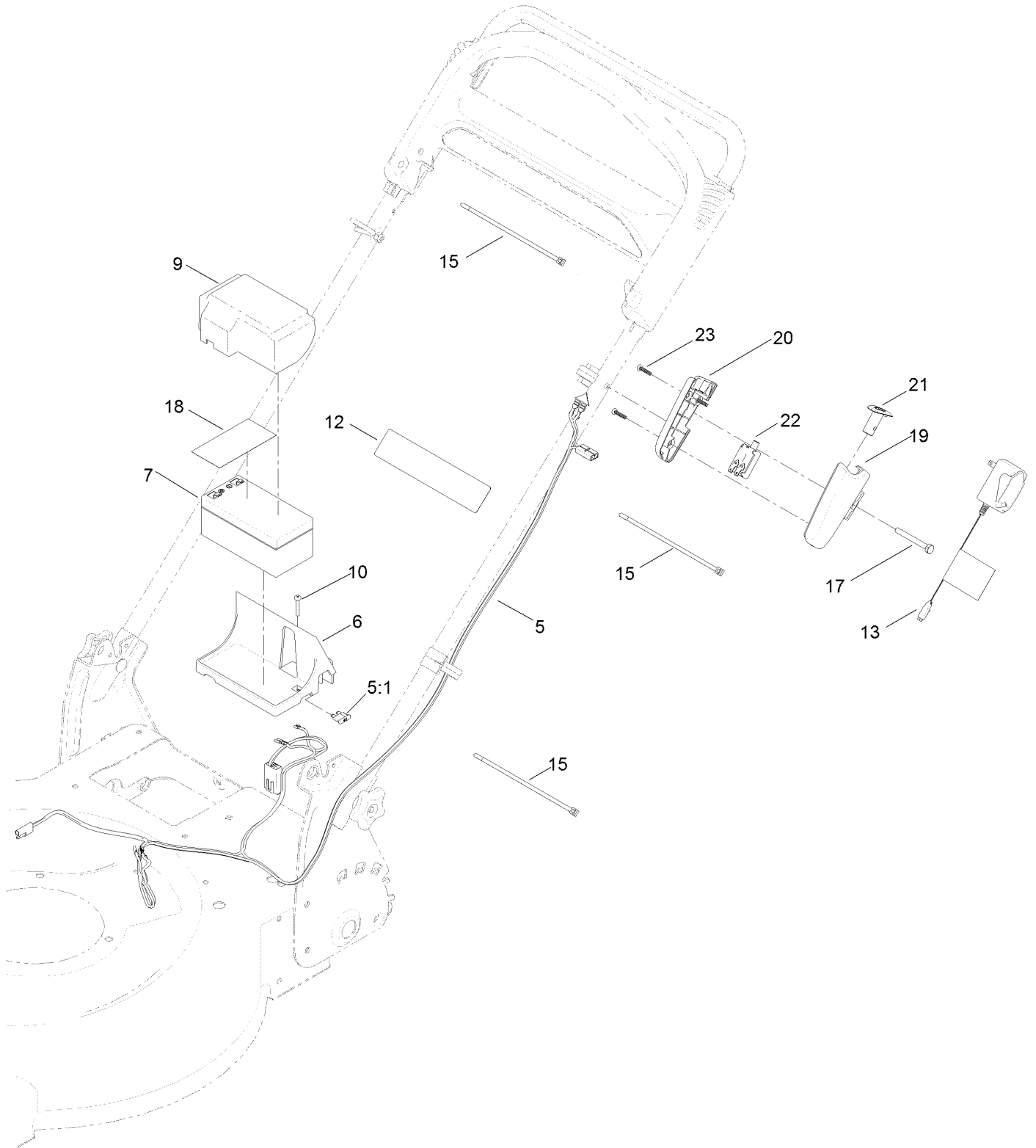

## Electrical Assembly (continued)

<i>Ref.</i>	<i>Part Number</i>	<i>Qty.</i>	<i>Description</i>	<i>Ref.</i>	<i>Part Number</i>	<i>Qty.</i>	<i>Description</i>
5	125-5024	1	Harness-Wire	15	614249	3	Tie-Cable
5:1	99-6124	1	Fuse-40 Amp	17	321-50	1	Screw-HH
6	114-7936	1	Tray-Battery	18	112-8763	1	Decal-Terminal, Battery
7	106-8397	1	Battery-Wet	19	125-2468	1	Housing-Switch, LH
9	120-3329	1	Cover-Battery	20	125-2469	1	Housing-Switch, RH
10	32144-97	1	Screw-PPH, Plastite	21	125-2470	1	Button-Switch
12	104-7953	1	Decal-Warning	22	121-9173	1	Switch-Push Button
13	114-1588	1	Charger-Battery	23	94-4496	3	Screw-PPH

# Attachments and Accessories

## For 20374 22in Recycler Lawn Mower

<b>Product Name</b>	<b>Model/Part</b>
Traction Assist Handle Kit.....	108-8120
High-Altitude Kit.....	121-4242
Engine Maintenance Kit.....	20240
Replacement Bag.....	59310
Replacement Frame and Bag Kit.....	59312
22 Inch Atomic Blade.....	59534P



**Notes:**

**Notes:**

**Notes:**



**Count on it.**