



**Count on it.**

**Parts Catalog**

**Dust-Control 66in Rake-O-Vac®  
Sweeper**

Model No. 07055—Serial No. 313000001 and Up



# Ordering Replacement Parts

To order replacement parts, please supply the part number, the quantity, and the description of each part desired.

## Understanding Reference Numbers

Each identified part in an illustration has a reference number. The reference number for a part also appears in the parts list, along with other information about the part.

This catalog uses two special reference number formats, one to indicate parts in a service assembly and another to indicate the quantity of a given part in an illustration.

## Service Assembly Reference Numbers

Parts in service assemblies have reference numbers in the form a:b. The a represents the reference number of the entire service assembly and the b represents a sequential number unique to each part within the service assembly.

For example, a wheel assembly might be identified by reference number 6, the tire by 6:1, the valve by 6:2, and the wheel by 6:3. When you order the assembly identified by reference number 6, you receive all parts identified by reference numbers 6:1, 6:2, and 6:3. However, you may also order any part individually. Reference numbers of this type appear in illustration and in parts lists.

## Reference Numbers Indicating Quantity

In an illustration, if a reference number indicates more than one part, the reference number has the form nX y. The n represents the quantity of the part, the X is the multiplication symbol, and the y represents the reference number.

For example, in an illustration, the reference number 2X 37 means that two of the parts identified by reference number 37 are indicated.

# Contents

Frame and Tire Assembly .....	4
Frame Decal Assembly .....	5
Wheel Hub Assembly .....	6
Blower and Throat Assembly .....	7
Blower Fan and Throat Flap Assembly .....	8
Blower and Throat Housing Assembly .....	9
Rake and Trailing Arm Assembly .....	10
LH Trailing Arm Assembly No. 117-8470 .....	11
Rake Assembly .....	12
Right Hand Trailing Arm Assembly .....	13
RH Trailing Arm Assembly No. 117-8460 .....	14
Engine, Clutch and Muffler Assembly .....	15
Centrifugal Clutch Assembly No. 107-1050 .....	17
Clutch Assembly No. 107-1070 .....	18
Guard Assembly .....	19
Battery and Fuel System Assembly .....	20
Fuel Tank Assembly No. 115-9047 .....	21
Hopper Assembly .....	22
Hopper and Hood Assembly .....	24

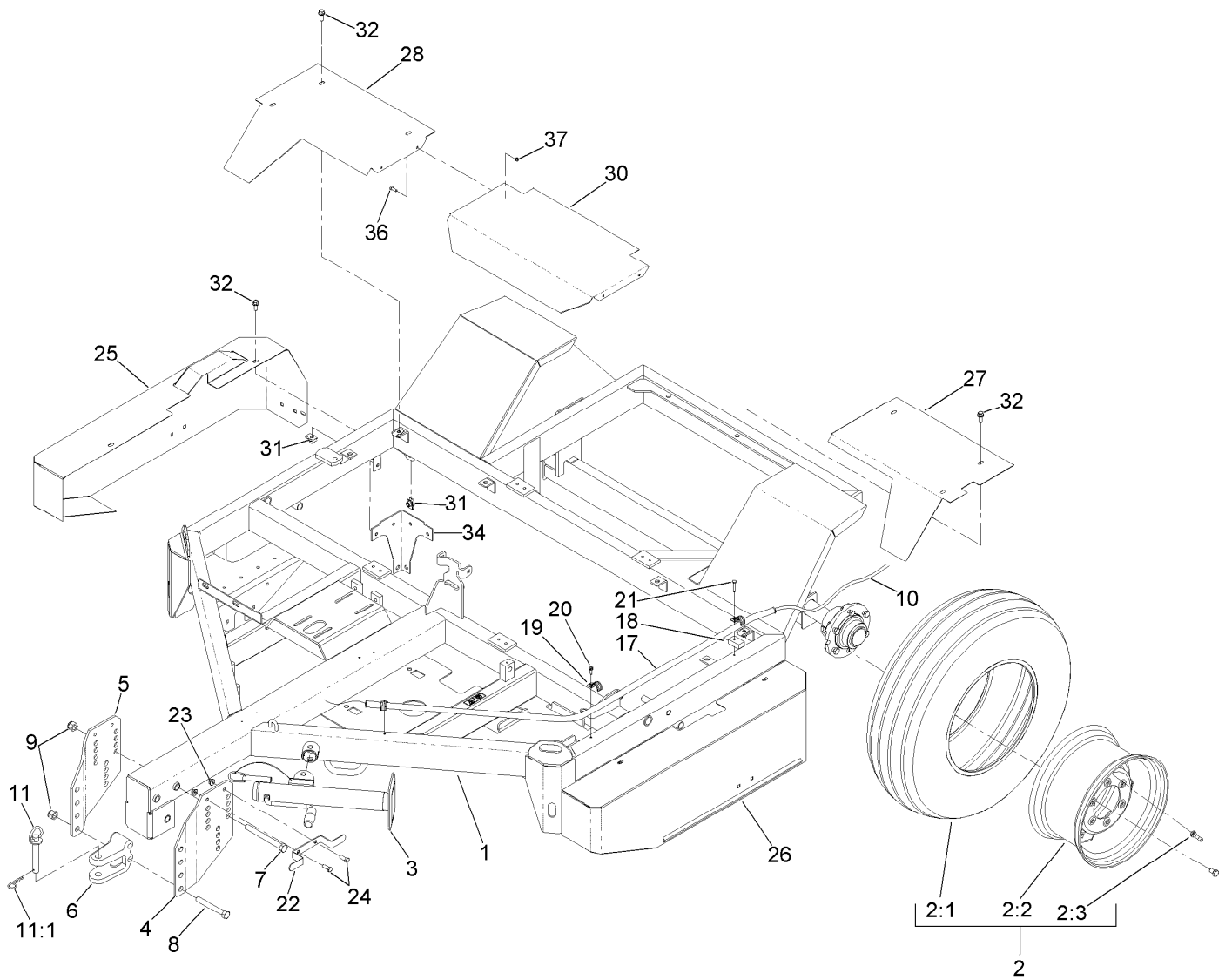

## Frame and Tire Assembly

Ref.	Part Number	Qty.	Description	Ref.	Part Number	Qty.	Description
1	120-6049	1	Frame And Axle ASM	19	2412-40	3	Clamp-Conduit
2	119-6224	2	Wheel And Tire ASM	20	32104-95	2	Screw-HWH
2:1	119-6225	1	Tire	21	32104-96	1	Screw-HH
2:2	119-6226	1	Wheel	22	106-0262-01	1	Mount-Harness
2:3	232-27	1	Stem-Valve	23	104-8301	6	Nut-HF, NI
3	106-9699	1	Jack	24	323-6	2	Screw-HH
4	110-7518-03	1	Plate-Hitch, LH	25	121-2778-03	1	Guard-Belt
5	110-7519-03	1	Plate-Hitch, RH	26	121-2784-03	1	Guard-Foot
6	47-3550-03	1	Hitch-Clevis	27	121-2682-03	1	Guard-Brush, LH
7	327-17	3	Screw-HH	28	121-2683-03	1	Cover-Brush, RH
8	327-12	2	Screw-HH	30	121-2686-03	1	Cover-Brush, Center
9	3296-53	5	Nut-Lock, NI	31	105-4886	12	Nut-Tinnerman
10	20-9580	1	Latch-Rope	32	110-5052	16	Screw-HHF
11	13-6200	1	Pin-Hitch, Pointed	34	121-2706-03	2	Support-Cover
11:1	3290-343	1	Pin-Hair	36	321-4	4	Screw-HH
17	13-6890-01	1	Guide-Rope	37	104-7201	4	Nut-HF
18	13-6910-01	1	Spacer-Guide, Rope				

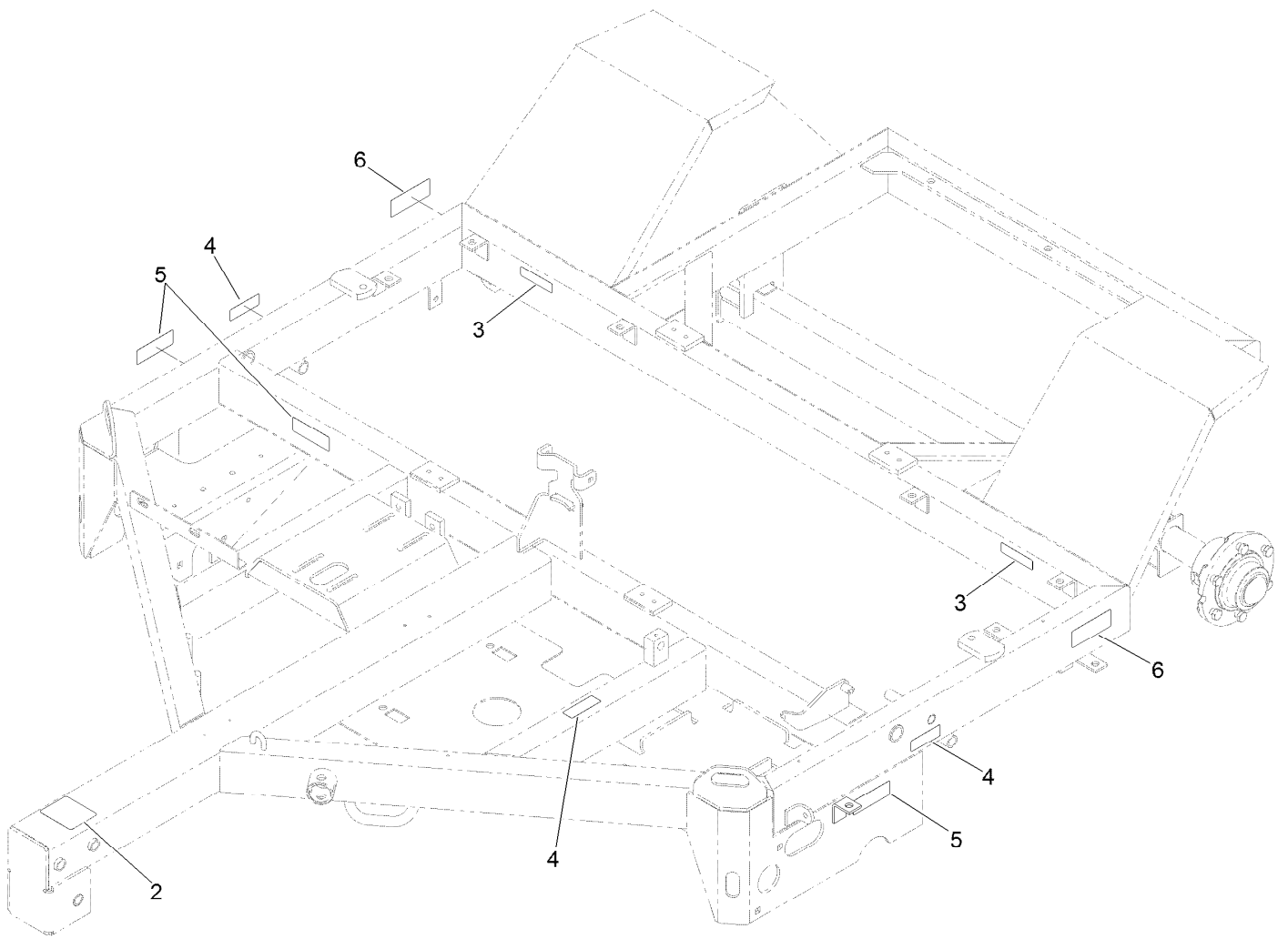

## Frame Decal Assembly

<i>Ref.</i>	<i>Part Number</i>	<i>Qty.</i>	<i>Description</i>
2	121-2836	1	Plate-Hitch, Caution
3	119-0217	2	Decal-Danger
4	120-0625	3	Decal-Warning, Pinch Point
5	117-4979	3	Decal-Warning, Shields
6	121-2840	2	Decal-Caution

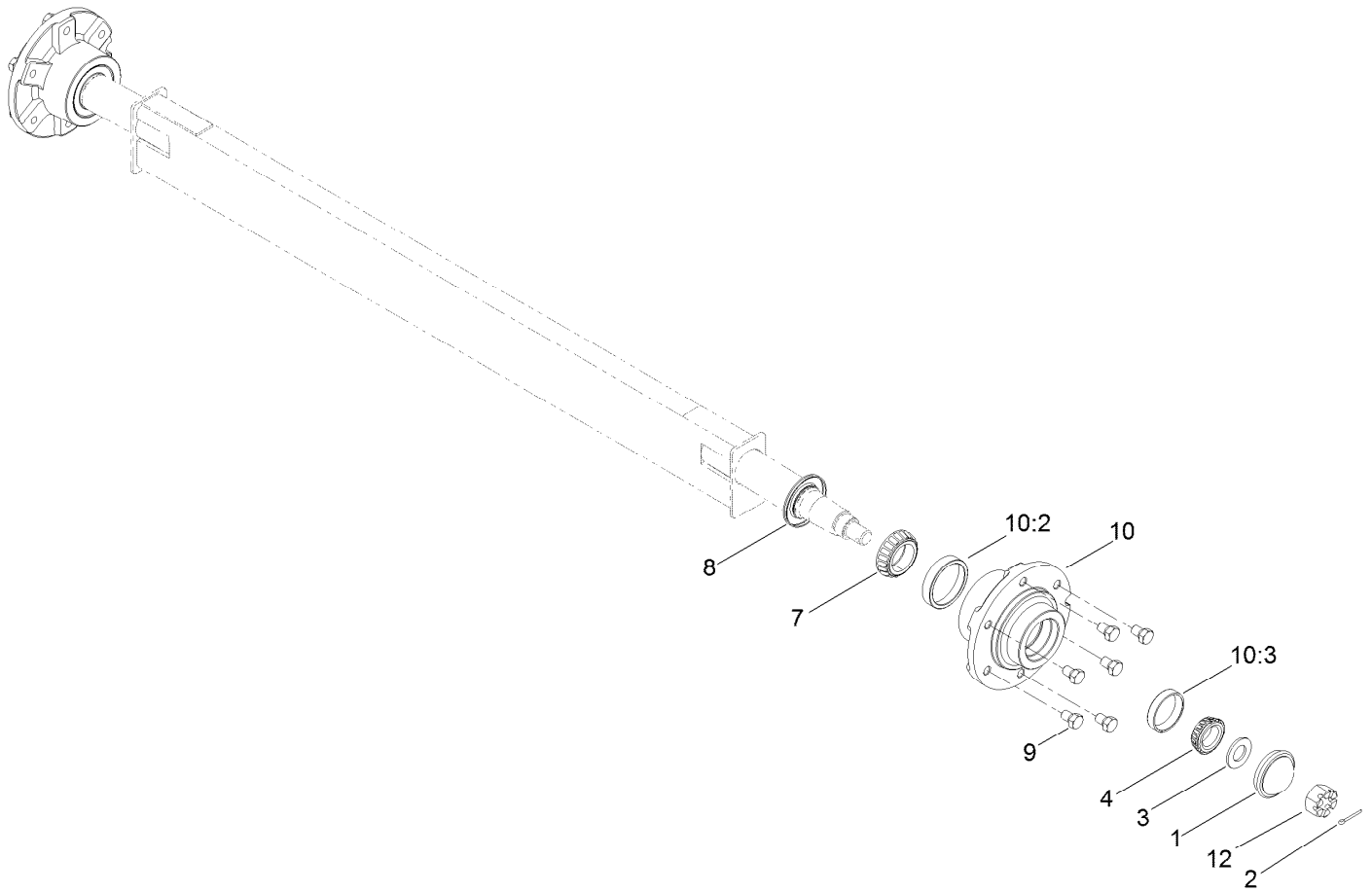

## Wheel Hub Assembly

<i>Ref.</i>	<i>Part Number</i>	<i>Qty.</i>	<i>Description</i>
1	217-111	2	Cap-Hub
2	3272-17	2	Pin-Cotter
3	3256-29	2	Washer-Flat
4	254-62	2	Bearing-Roller, Cone
7	254-65	2	Bearing-Roller, Cone
8	253-127	2	Seal
9	217-103	12	Bolt-Wheel
10	117-8535	2	Hub-Cupped
10:2	254-66	1	Cup-Bearing, Roller
10:3	254-61	1	Cup-Bearing, Roller
12	32136-1	2	Nut-Slotted

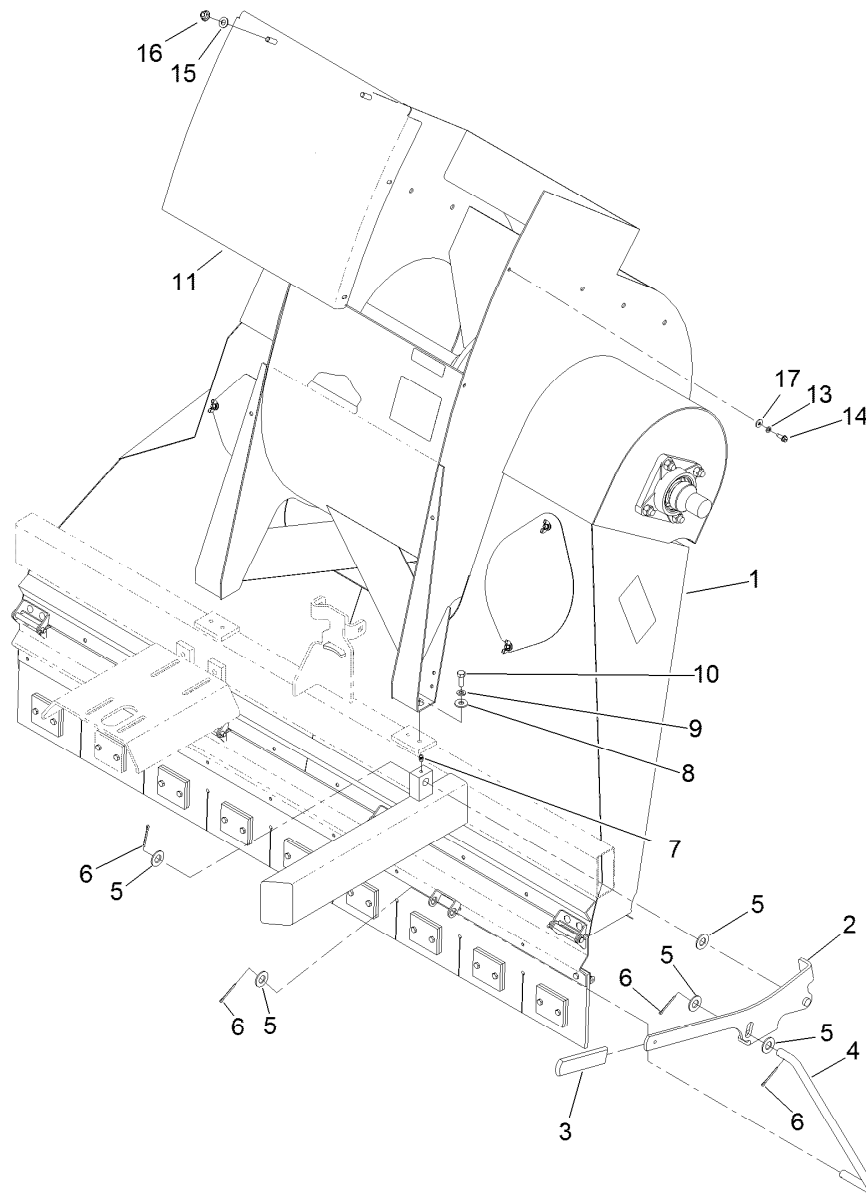

## Blower and Throat Assembly

<i>Ref.</i>	<i>Part Number</i>	<i>Qty.</i>	<i>Description</i>	<i>Ref.</i>	<i>Part Number</i>	<i>Qty.</i>	<i>Description</i>
1		1	Blower And Throat ASM ●	9	3253-21	8	Washer-Lock
2	120-5965-03	1	Handle-Flap	10	323-6	8	Screw-HH
3	105-3450	1	Grip-Lever, Lift	11	119-6442-01	1	Door-Access
4	120-5966	1	Rod-Flap Lift	13	3253-3	4	Washer-Lock
5	3256-27	5	Washer-Flat	14	32104-95	4	Screw-HWH
6	3272-13	4	Pin-Cotter	15	3256-24	2	Washer-Flat
7	302-5	1	Fitting-Grease	16	104-8301	2	Nut-HF, NI
8	80-6990	8	Washer-Hardened	17	3256-22	4	Washer-Flat

● Not serviced separately

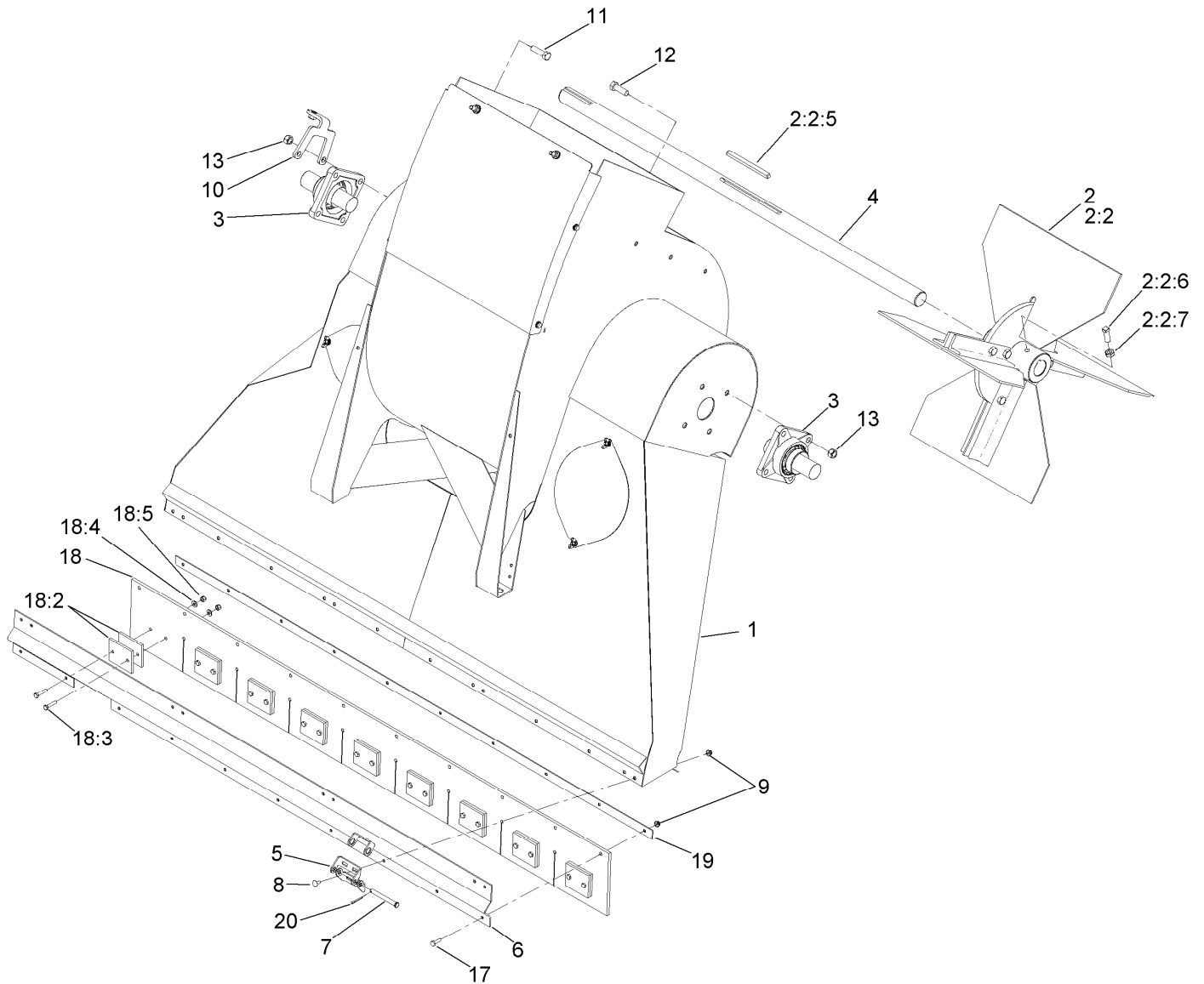

## Blower Fan and Throat Flap Assembly

Ref.	Part Number	Qty.	Description	Ref.	Part Number	Qty.	Description
1	119-6263	1	Blower And Throat ASM	10	108-0893-03	1	Mount-Guard, Fan
2	13-3420-03	1	Fan ASM	11	325-7	4	Screw-HH
2:2		1	Fan ●	12	325-6	4	Screw-HH
2:2:5	13-2810	1	Square Key	13	32153-5	8	Nut-Hex
2:2:6	3244-14	4	Screw-Set, SQH	17	321-5	10	Screw-HH
2:2:7	3218-5	4	Nut-Jam	18	13-4700	1	Lower Flap ASM
3	56-6220	2	Bearing	18:2	13-4560-03	18	Weight-Flap
4	13-3790	1	Fan Shaft	18:3	321-8	18	Screw-HH
5	107-1549	8	Hinge-Half	18:4	3256-22	18	Washer-Flat
6	120-5960-03	1	Flap-Blade, Lower	18:5	3296-42	18	Nut-Lock, NI
7	80-2570	4	Pin-Clevis	19	13-1390-03	1	Flap Retainer
8	3229-11	16	Screw-CARR	20	3272-11	4	Pin-Cotter
9	104-7201	26	Nut-HF				

● Not serviced separately



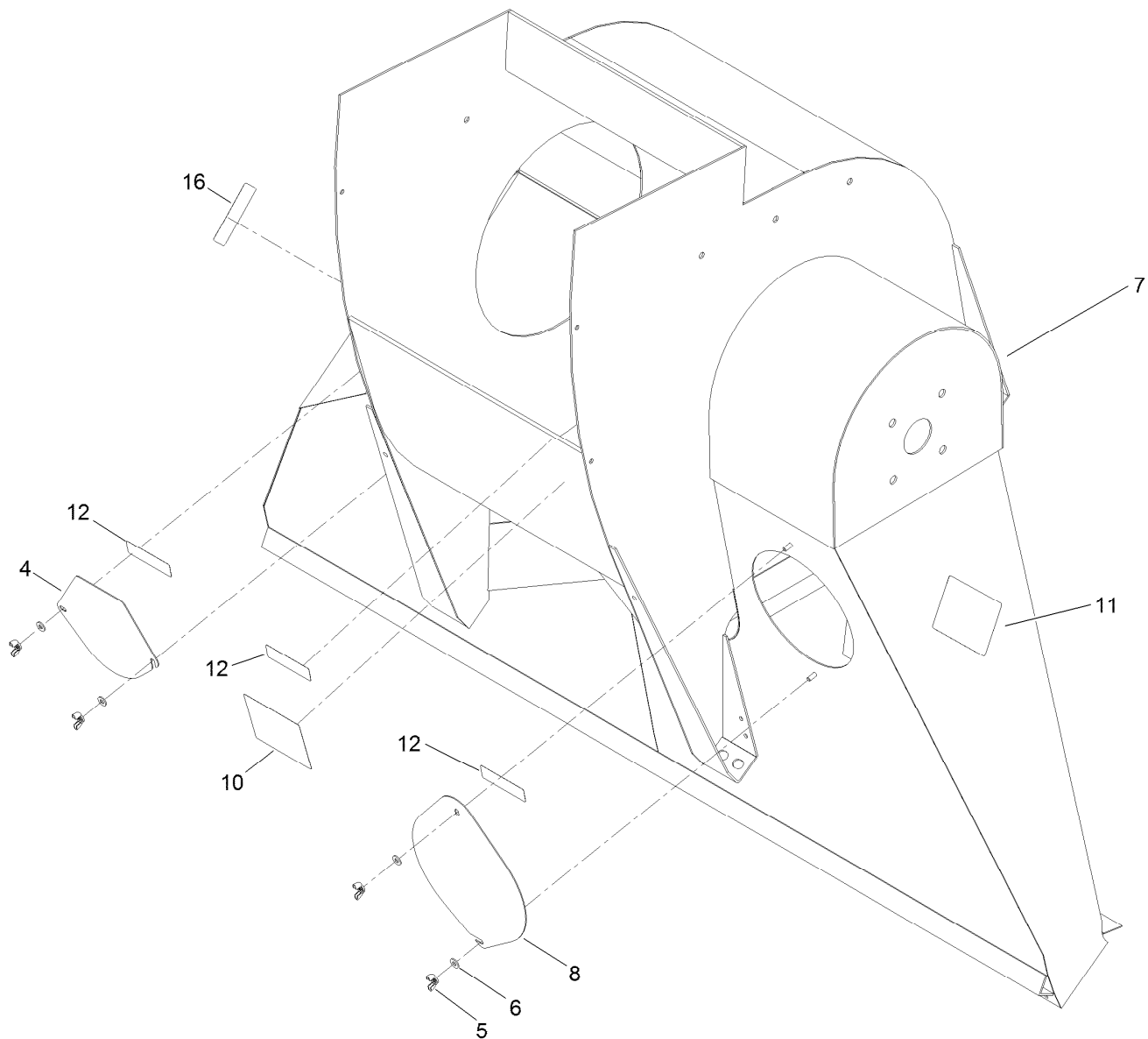

## Blower and Throat Housing Assembly

<i>Ref.</i>	<i>Part Number</i>	<i>Qty.</i>	<i>Description</i>
4	13-1420-01	1	Cover-Inspection
5	32103-12	4	Nut-Wing
6	3256-22	4	Washer-Flat
7	93-4010-01	1	Blower And Throat ASM
8	93-4020-01	1	Cover-Inspection
10	121-2839	1	Decal-Caution
11	121-2842	1	Decal-Instruction
12	121-2843	3	Decal-Warning
16	117-4979	1	Decal-Warning, Shields

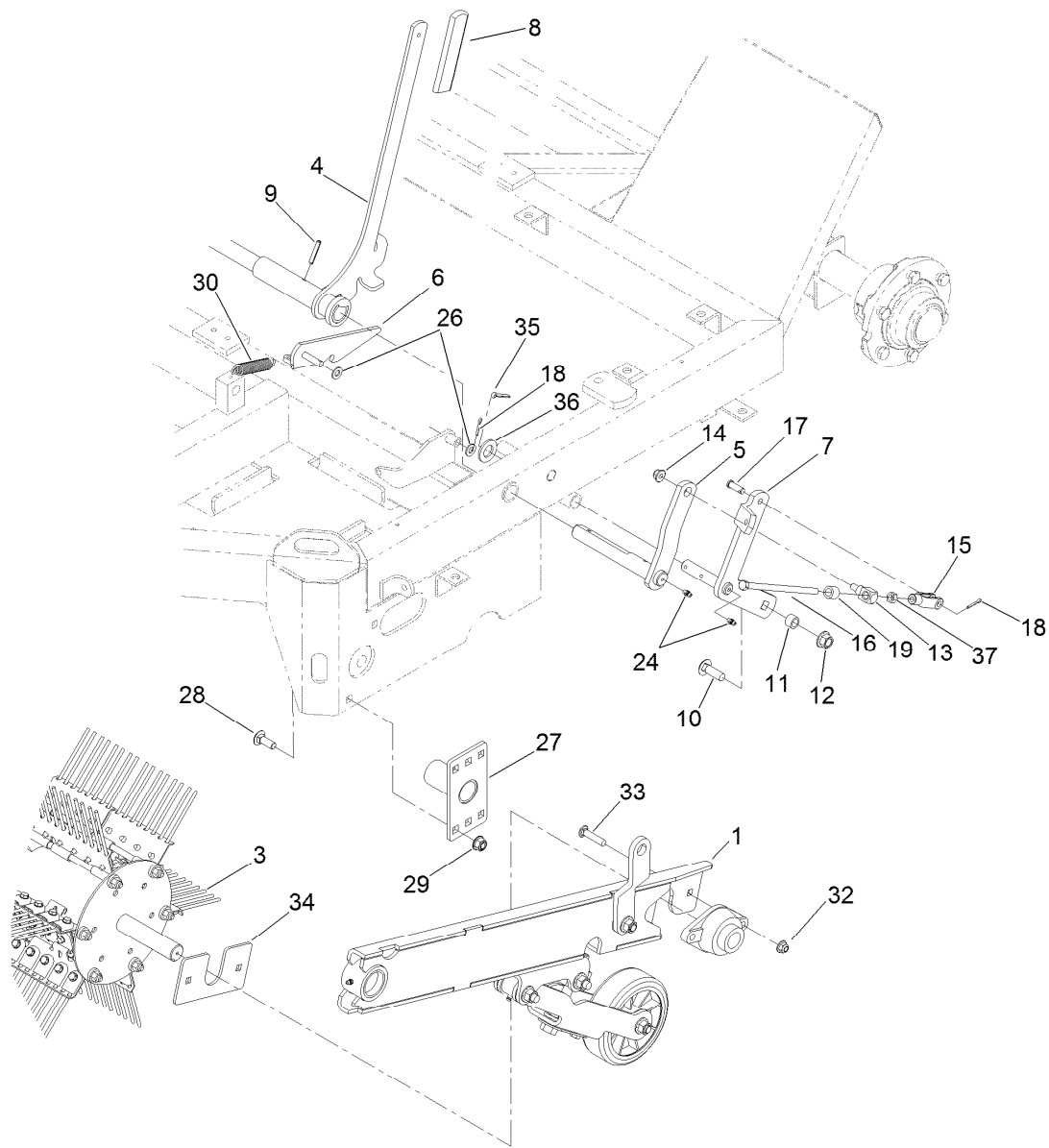

## Rake and Trailing Arm Assembly

Ref.	Part Number	Qty.	Description	Ref.	Part Number	Qty.	Description
1	117-8470	1	LH Trailing Arm ASM	17	283-2	2	Pin-Clevis
3		1	Flex Tip Reel ASM ●	18	3272-10	3	Pin-Cotter
4	119-6200-03	1	Handle-Lift	19	95-8603	2	Spacer
5	119-2994	2	Crank-Lifting, Rake	24	302-5	4	Fitting-Grease
6	117-8490-03	1	Handle-Trip	26	3256-24	2	Washer-Flat
7	117-8503-03	1	Crank-Bell, Lifting LH	27	117-8506-03	1	Mount-Guard
8	105-3450	1	Grip-Lever, Lift	28	3232-3	2	Bolt-CARR
9	32121-15	2	Pin-Roll	29	114-8417	2	Nut-HF, NI
10	3233-2	1	Screw-CARR	30	13-0480	1	Spring
11	119-6188	1	Tube-Pivot	32	104-8301	2	Nut-HF, NI
12	99-5107	1	Nut-Lock	33	3231-29	2	Screw-CARR
13	13-0100	2	Pivot-Link, Rake Lift	34	119-6217-03	1	Support-Arm, Trailing
14	104-8301	2	Nut-HF, NI	35	3272-22	1	Pin-Cotter
15	282-22	2	Clevis	36	3256-28	1	Washer-Flat
16	27-7900	2	Screw-Adjusting	37	3219-3	2	Nut-Hex

● Not serviced separately

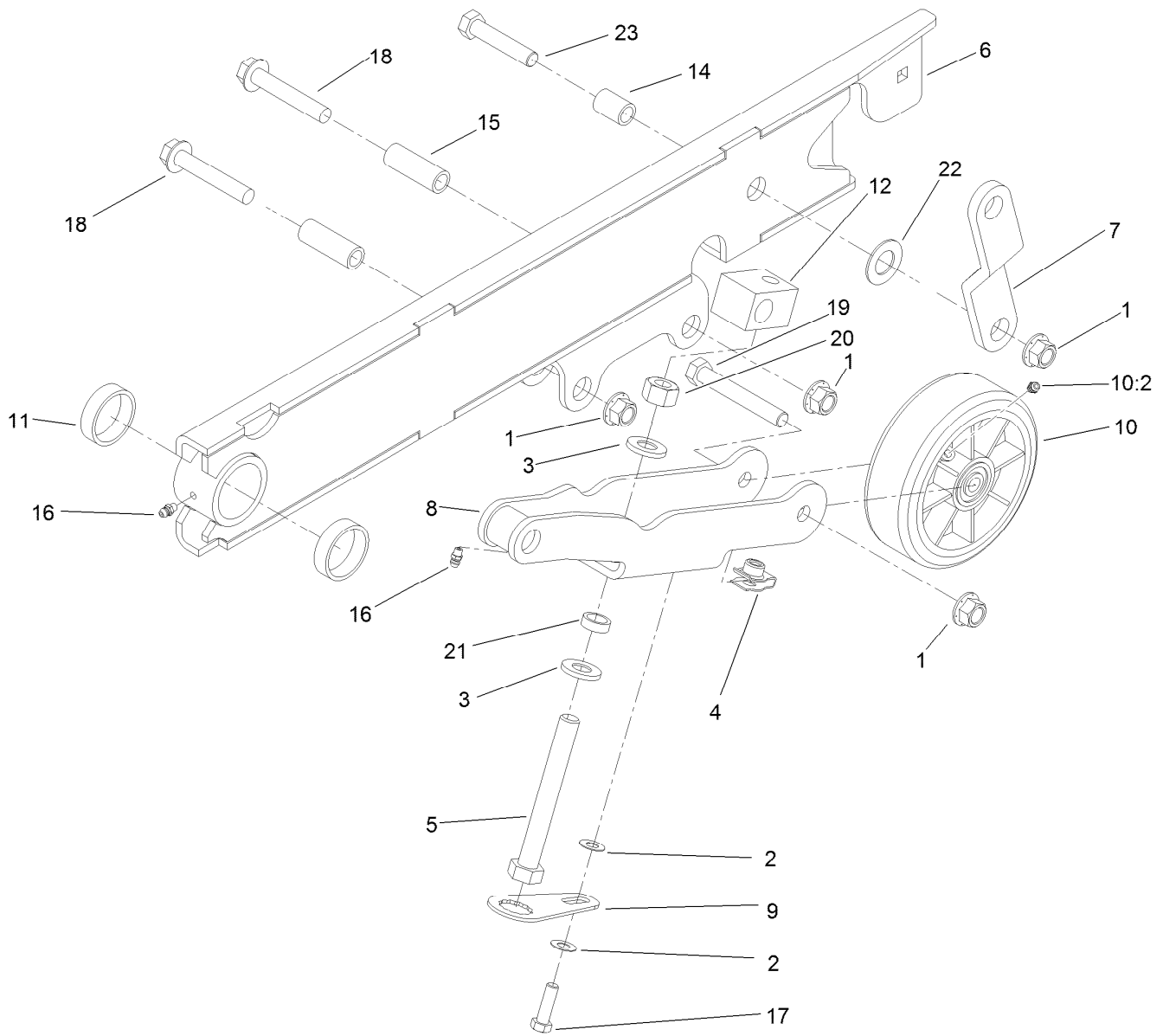

## LH Trailing Arm Assembly No. 117-8470

<i>Ref.</i>	<i>Part Number</i>	<i>Qty.</i>	<i>Description</i>	<i>Ref.</i>	<i>Part Number</i>	<i>Qty.</i>	<i>Description</i>
1	99-5107	4	Nut-Lock	12	119-6184	1	Block-Pivot
2	108-1438	2	Washer-Hardened	14	119-6191	1	Tube-Pivot
3	99-7667	2	Washer-Flat	15	119-6192	2	Tube-Pivot
4	112-4576	1	Nut-Clip, U	16	302-5	2	Fitting-Grease
5	112-4874	1	Screw-HH, TAP	17	323-6	1	Screw-HH
6	120-5905-03	1	Arm-Trailing	18	3234-40	2	Screw-HF
7	117-8465-03	1	Link-Lift	19	325-14	1	Screw-HH
8	119-6301-03	1	Arm-Gauge, Wheel	20	3217-11	1	Nut-Hex
9	117-8484	1	Tab-Locking	21	119-6253	1	Spacer-Limiter
10	117-8544	1	Wheel-Caster	22	69-8930	1	Washer
10:2	302-5	1	Fitting-Grease	23	325-10	1	Screw-HH
11	119-2985	2	Bushing				

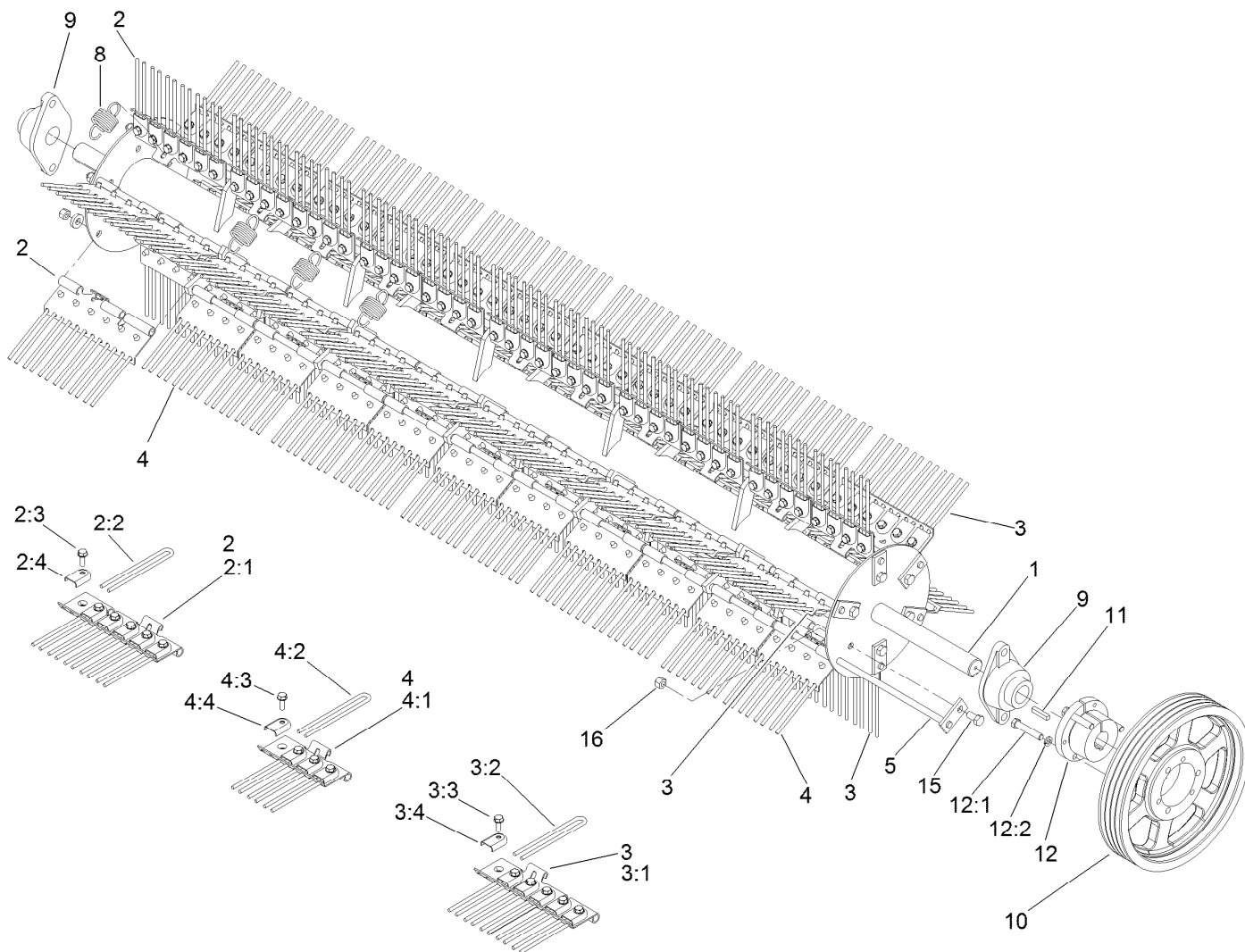

## Rake Assembly

Ref.	Part Number	Qty.	Description
1	93-0197-01	1	Reel ASM
2		3	Left Plate ASM ●
2:1	115-9028	1	End Plate ASM
2:2	115-9022	6	Finger-Plastic
2:3	32140-94	6	Screw-HH, Sems
2:4	115-9023	6	Clamp-Finger
3		3	Right Plate ASM ●
3:1	115-9026	1	End Plate ASM
3:2	115-9022	6	Finger-Plastic
3:3	32140-94	6	Screw-HH, Sems
3:4	115-9023	6	Clamp-Finger
4		60	Center Plate ASM ●
4:1	115-9024	1	Plate-Center

Ref.	Part Number	Qty.	Description
4:2	115-9022	4	Finger-Plastic
4:3	32140-94	4	Screw-HH, Sems
4:4	115-9023	4	Clamp-Finger
5	13-4960	6	Shaft-Plate, Finger
8	13-3090	66	Spring-Finger
9	56-6230	2	Bearing-Roller
10	93-4001	1	Pulley-4 Groove
11	13-2840	1	Key-Square
12	13-2680	1	Bushing
12:1	120-6000	3	Bolt-TAP, HH
12:2	3253-4	3	Washer-Lock
15	323-4	6	Screw-HH
16	32152-2	12	Nut-Lock, Cone

● Not serviced separately

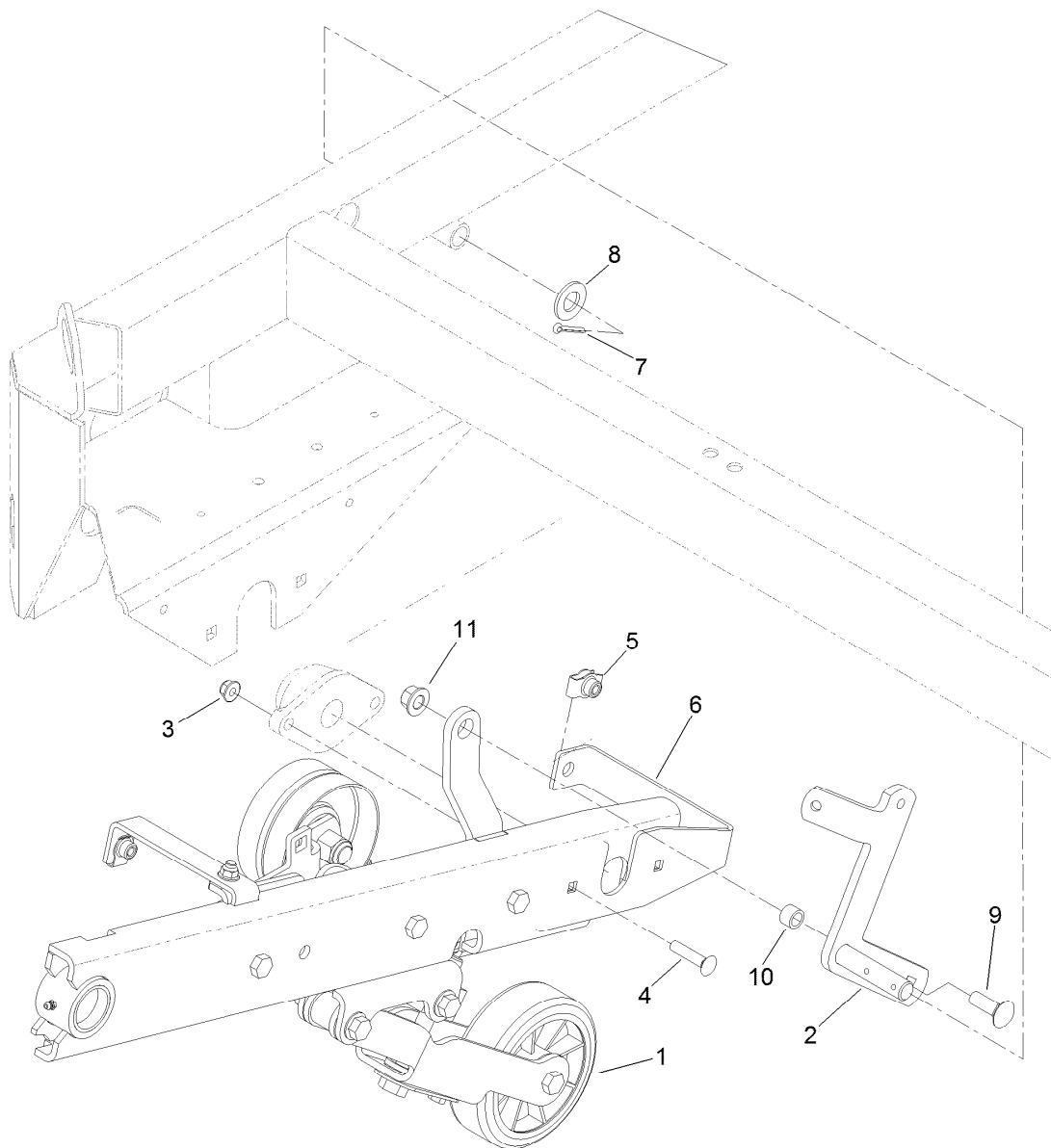

## Right Hand Trailing Arm Assembly

<i>Ref.</i>	<i>Part Number</i>	<i>Qty.</i>	<i>Description</i>
1	117-8460	1	RH Trailing Arm ASM
2	117-8504-03	1	Crank-Bell, Lifting RH
3	104-8301	2	Nut-HF, NI
4	3231-29	2	Screw-CARR
5	112-4576	1	Nut-Clip, U
6	121-2771-03	1	Brace-Cover, Belt
7	3272-22	1	Pin-Cotter
8	3256-28	1	Washer-Flat
9	3233-2	1	Screw-CARR
10	119-6188	1	Tube-Pivot
11	99-5107	1	Nut-Lock

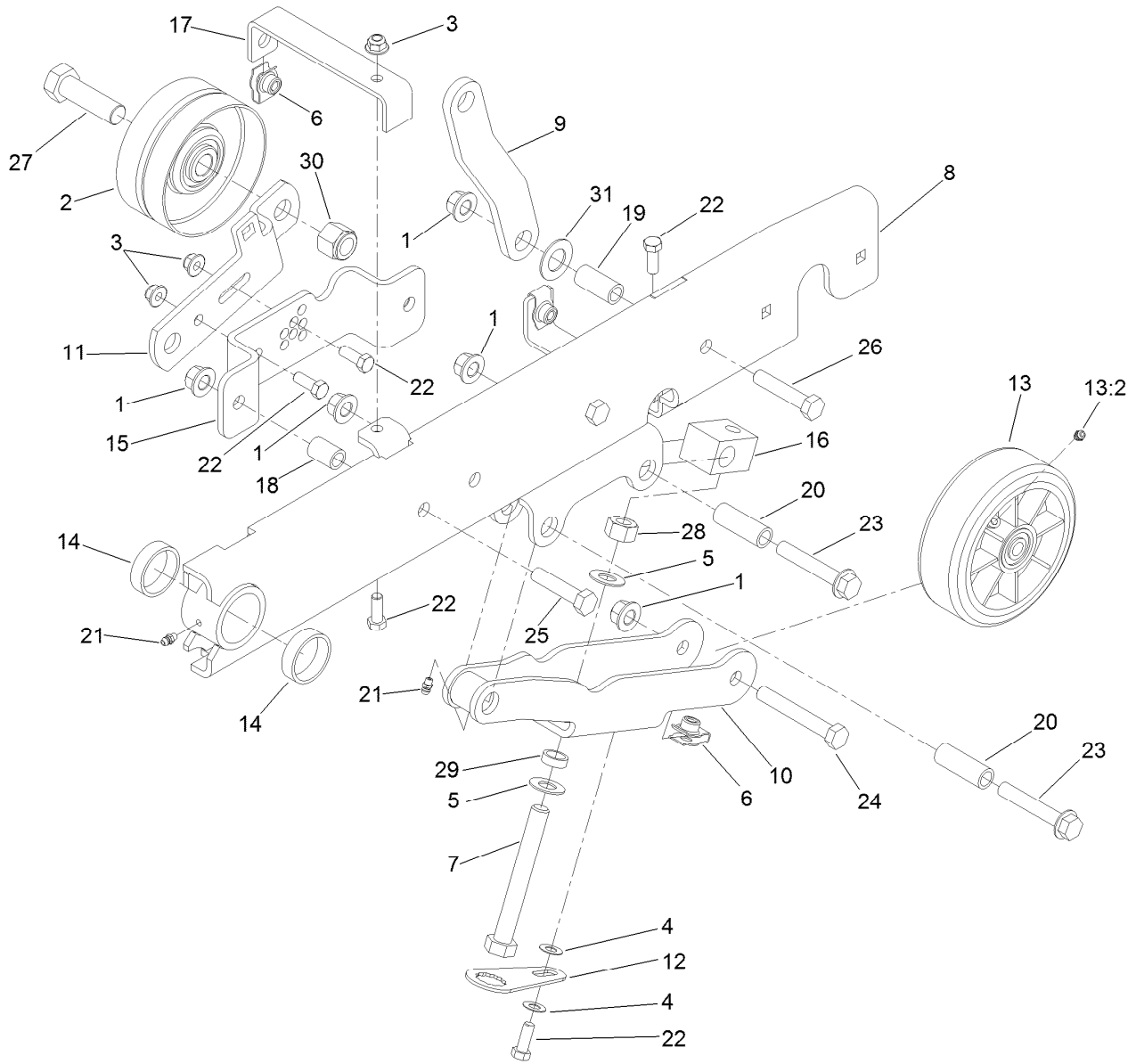

## RH Trailing Arm Assembly No. 117-8460

Ref.	Part Number	Qty.	Description	Ref.	Part Number	Qty.	Description
1	99-5107	6	Nut-Lock	16	119-6184	1	Block-Pivot
2	100-7631	1	Pulley-Idler	17	121-2772-03	2	Support-Cover, Belt
3	104-8301	4	Nut-HF, NI	18	119-6189	2	Tube-Pivot
4	108-1438	2	Washer-Hardened	19	119-6191	1	Tube-Pivot
5	99-7667	2	Washer-Flat	20	119-6192	2	Tube-Pivot
6	112-4576	3	Nut-Clip, U	21	302-5	2	Fitting-Grease
7	112-4874	1	Screw-HH, TAP	22	323-6	5	Screw-HH
8	117-8461-03	1	Arm-Trailing	23	3234-40	2	Screw-HF
9	117-8465-03	1	Link-Lift	24	325-14	1	Screw-HH
10	119-6301-03	1	Arm-Gauge, Wheel	25	325-9	2	Screw-HH
11	117-8469-03	1	Bracket-Pulley	26	325-10	1	Screw-HH
12	117-8484	1	Tab-Locking	27	328-2	1	Screw-HH
13	117-8544	1	Wheel-Caster	28	3217-11	1	Nut-Hex
13:2	302-5	1	Fitting-Grease	29	119-6253	1	Spacer-Limiter
14	119-2985	2	Bushing	30	3296-51	1	Nut-Lock, NI
15	119-2992-03	1	Bracket-Adjust, Tension	31	69-8930	1	Washer

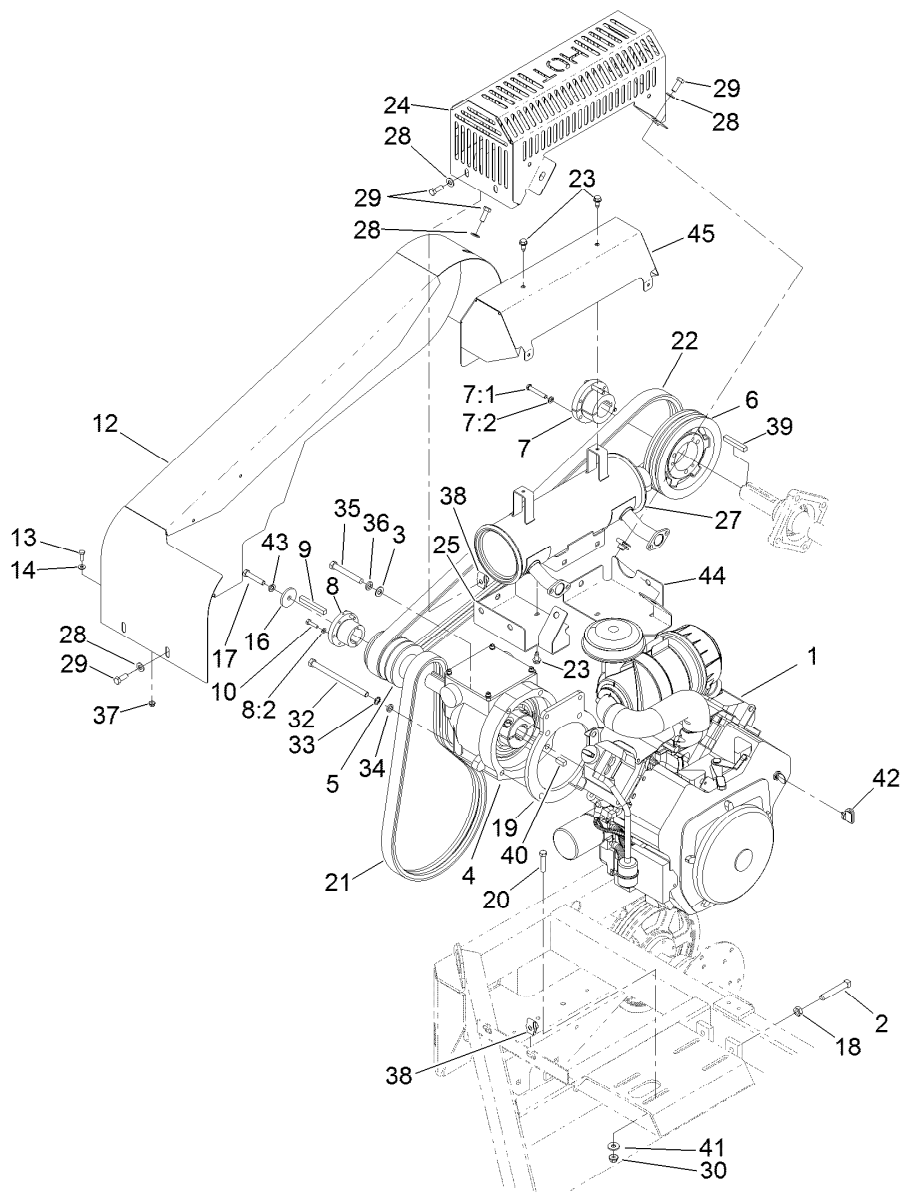

## Engine, Clutch and Muffler Assembly

Ref.	Part Number	Qty.	Description	Ref.	Part Number	Qty.	Description
1		1	Engine-Kohler, Ch680-Ps660062 ■▲	16	4-1920	1	Washer
1:1	108-3847	1	Filter-Oil ●	17	323-10	1	Screw-HH
2	3244-21	2	Screw-SQH	18	3218-5	2	Nut-Jam
3	3256-25	2	Washer-Flat	19	119-6137-03	1	Plate-Adapter
4	107-1050	1	Clutch-Centrifugal	20	323-9	4	Screw-HH
5	13-3320	1	Sheave	21	13-2650	1	Belt-V
6	13-2800	1	Sheave	22	93-0183	1	Belt-V, Impeller
7	13-2970	1	Bushing	23	32104-32	6	Screw-HWH
7:1	120-6000	3	Bolt-TAP, HH	24	121-2850-03	1	Shield-Muffler
7:2	3253-4	3	Washer-Lock	25	121-2851-03	1	Shield-Heat, Front Bottom
8	13-3330	1	Bushing	27	120-5956	1	Muffler ASM
8:2	3253-3	3	Washer-Lock	28	3256-24	10	Washer-Flat
9	3-9155	1	Key-Square	29	323-6	10	Screw-HH
10	321-6	3	Screw-HH	30	104-8301	4	Nut-HF, NI
12	117-8510-03	1	Guard-Belt	32	324-31	2	Screw-HH
13	321-4	2	Screw-HH	33	3255-16	2	Washer-Lock/EXT
14	3256-22	2	Washer-Flat	34	37-4700	2	Spacer-Wheel
				35	324-13	2	Screw-HH

● Not illustrated

▲ Obtain parts from [www.kohlerplus.com](http://www.kohlerplus.com)

■ Not serviced separately

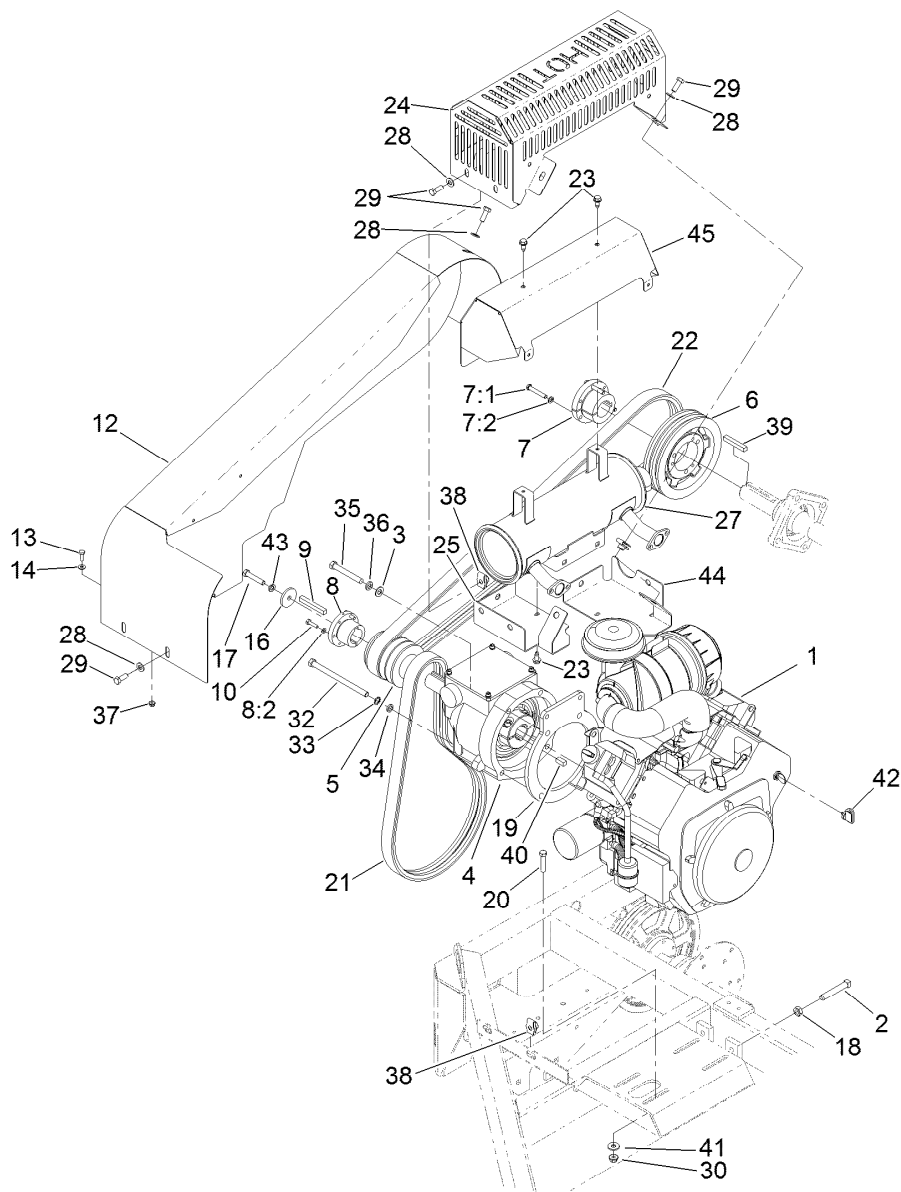

## Engine, Clutch and Muffler Assembly (continued)

<i>Ref.</i>	<i>Part Number</i>	<i>Qty.</i>	<i>Description</i>	<i>Ref.</i>	<i>Part Number</i>	<i>Qty.</i>	<i>Description</i>
36	3253-6	2	Washer-Lock	41	80-6990	4	Washer-Hardened
37	104-7201	2	Nut-HF	42	63-8360	1	Key-Ignition
38	105-4886	9	Nut-Tinnerman	43	3253-21	1	Washer-Lock
39	13-2240	1	Key-Square	44	121-2848-03	1	Shield-Heat, Back Bottom
40	105-7864	1	Key-Square	45	121-2865-03	1	Shield-Heat, Inner

● Not illustrated  
▲ Obtain parts from [www.kohlerplus.com](http://www.kohlerplus.com)

■ Not serviced separately



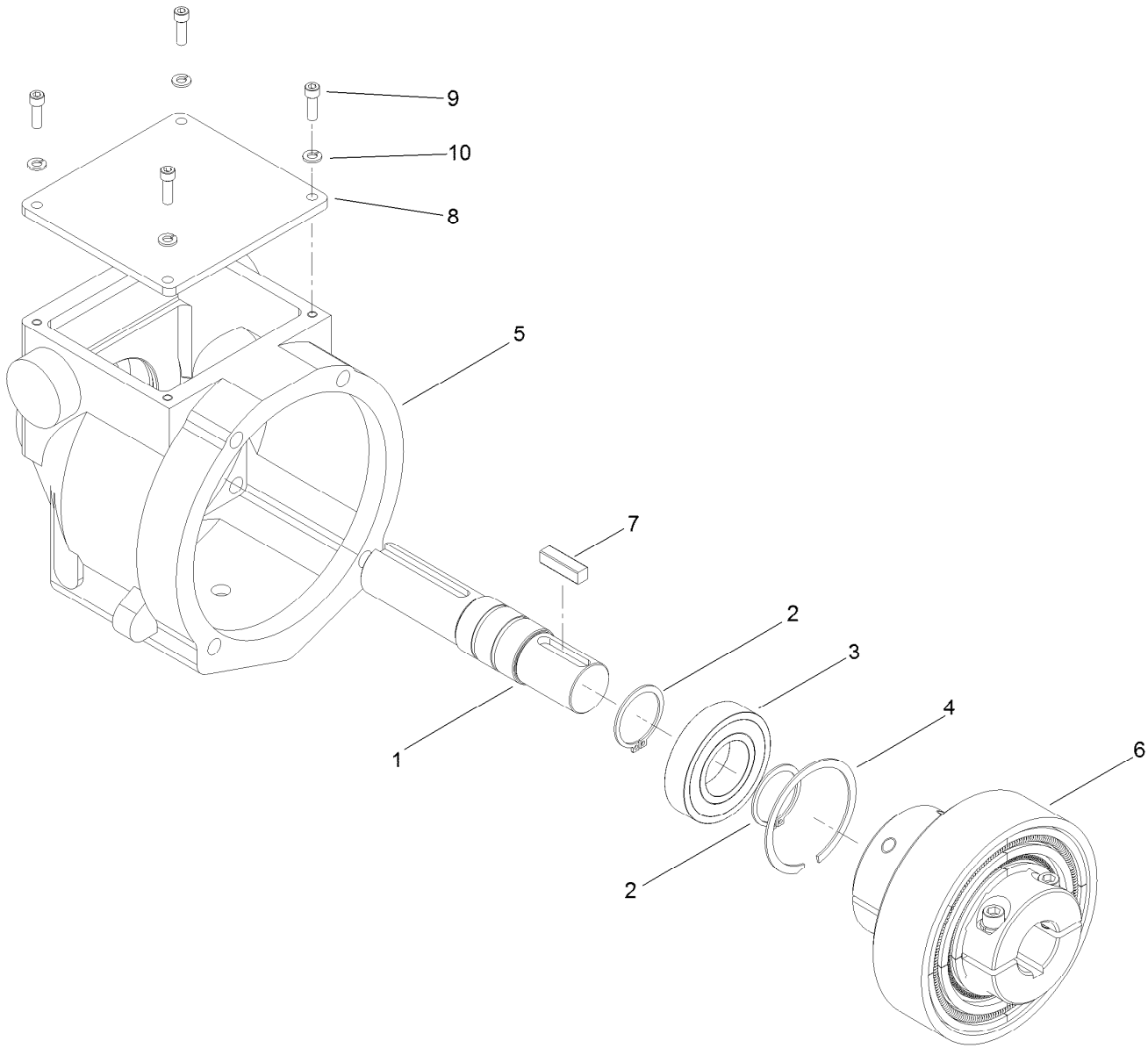

## Centrifugal Clutch Assembly No. 107-1050

<i>Ref.</i>	<i>Part Number</i>	<i>Qty.</i>	<i>Description</i>
1	107-1052	1	Shaft
2	107-1053	2	Ring-Retaining
3	107-1054	1	Bearing
4	107-1055	1	Ring-Retaining
5		1	Housing ●
6	107-1070	1	Centrifugal Clutch ASM
7	107-1057	1	Key
8	107-1058	1	Cover
9	3274-8	4	Screw-HSH
10	3253-3	4	Washer-Lock

● Not serviced separately

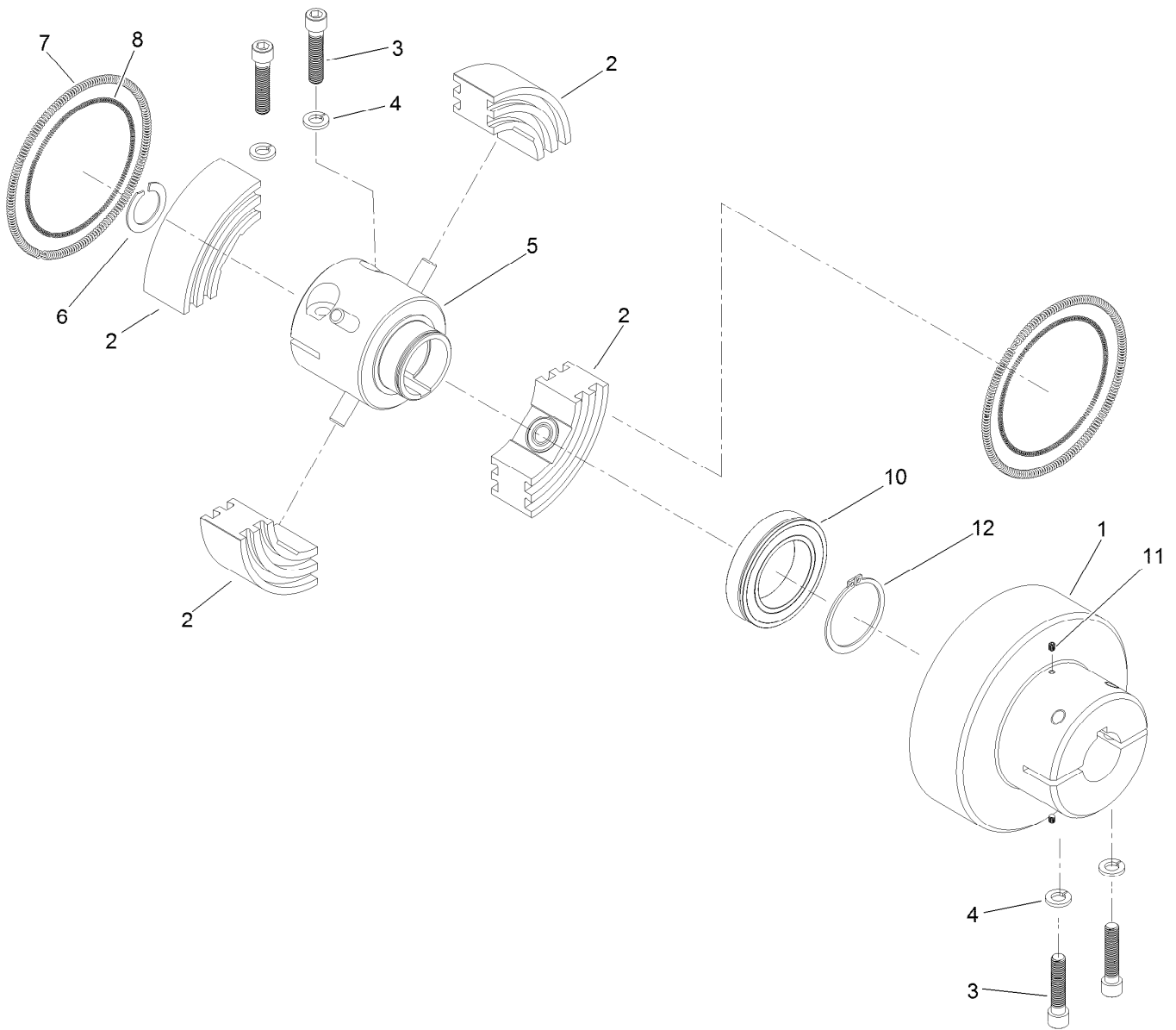

## Clutch Assembly No. 107-1070

Ref.	Part Number	Qty.	Description
1		1	Housing-Clutch ●
2	107-1072	4	Shoe ASM
3	3274-3	4	Screw-HSH
4	3253-21	4	Washer-Lock
5	107-1081	1	Hub ASM
6	107-1074	1	Ring-Retaining
7	107-1075	2	Spring
8	107-1076	2	Spring
10	107-1078	1	Bearing
11	107-1079	2	Point-Cone
12	107-1080	1	Ring-Retaining

● Not serviced separately

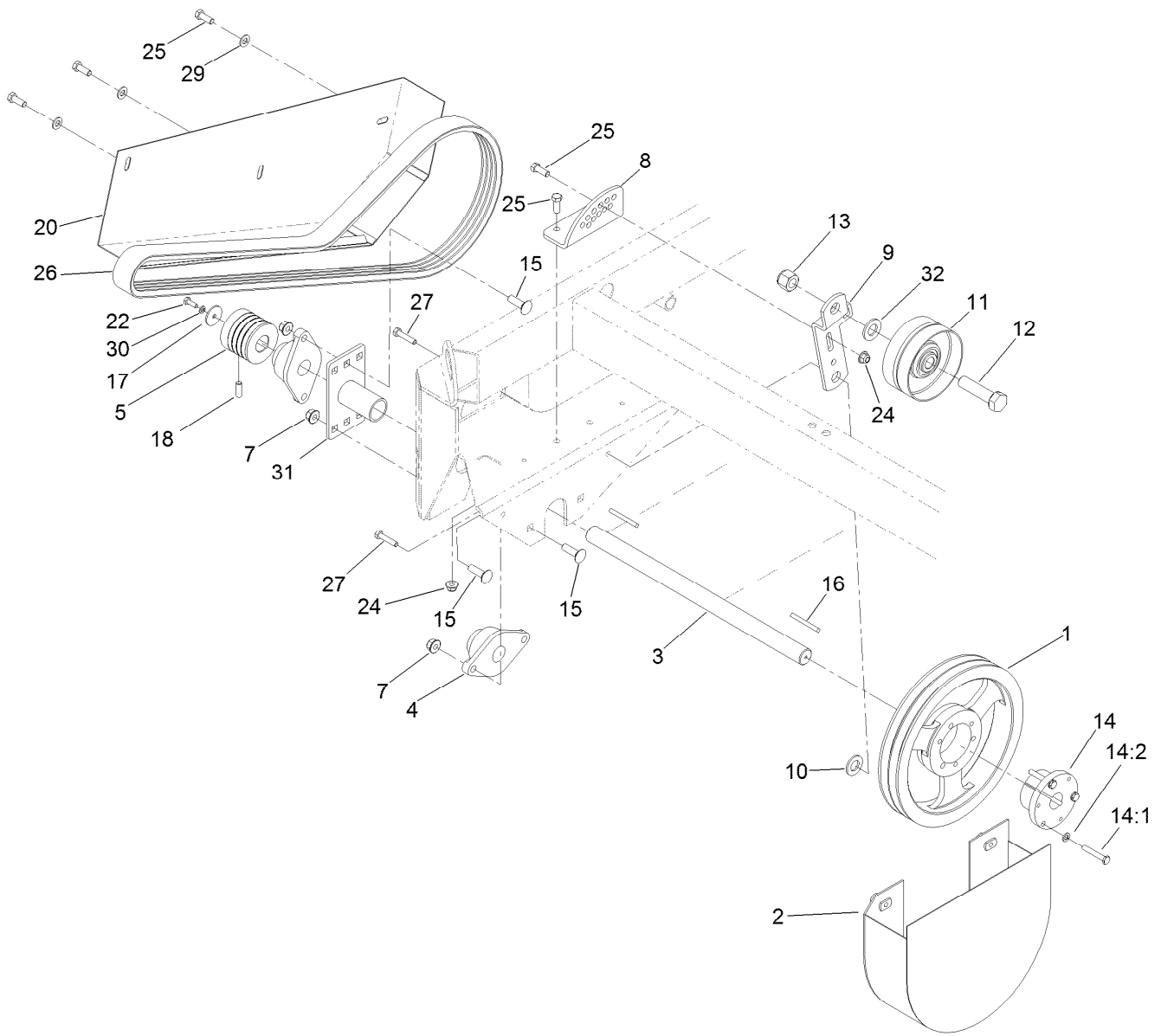

## Guard Assembly

<i>Ref.</i>	<i>Part Number</i>	<i>Qty.</i>	<i>Description</i>	<i>Ref.</i>	<i>Part Number</i>	<i>Qty.</i>	<i>Description</i>
1	13-2670	1	Sheave	15	3232-3	6	Bolt-CARR
2	120-5914-03	1	Guard-Sheave	16	68-3220	2	Key-Stock
3	93-4032	1	Shaft-Jack	17	13-3710	1	Washer
4	56-6230	2	Bearing-Roller	18	3247-6	2	Screw-Set
5	93-4033-01	1	Pulley-Driver	20	121-2780-03	1	Guard-Lower, Belt
7	114-8417	6	Nut-HF, NI	22	321-4	1	Screw-HH
8	117-8538-03	1	Bracket-Idler Arm	24	104-8301	3	Nut-HF, NI
9	117-8469-03	1	Bracket-Pulley	25	323-6	6	Screw-HH
10	3-8448	1	Washer-Thrust	26	93-4034	1	V-Belt
11	100-7631	1	Pulley-Idler	27	322-7	2	Screw-HH
12	328-25	1	Screw-HH	29	3256-24	3	Washer-Flat
13	3296-51	1	Nut-Lock, NI	30	3253-3	1	Washer-Lock
14	13-2680	1	Bushing	31	117-8506-03	1	Mount-Guard
14:1	120-6000	3	Bolt-TAP, HH	32	3256-28	3	Washer-Flat
14:2	3253-4	3	Washer-Lock				

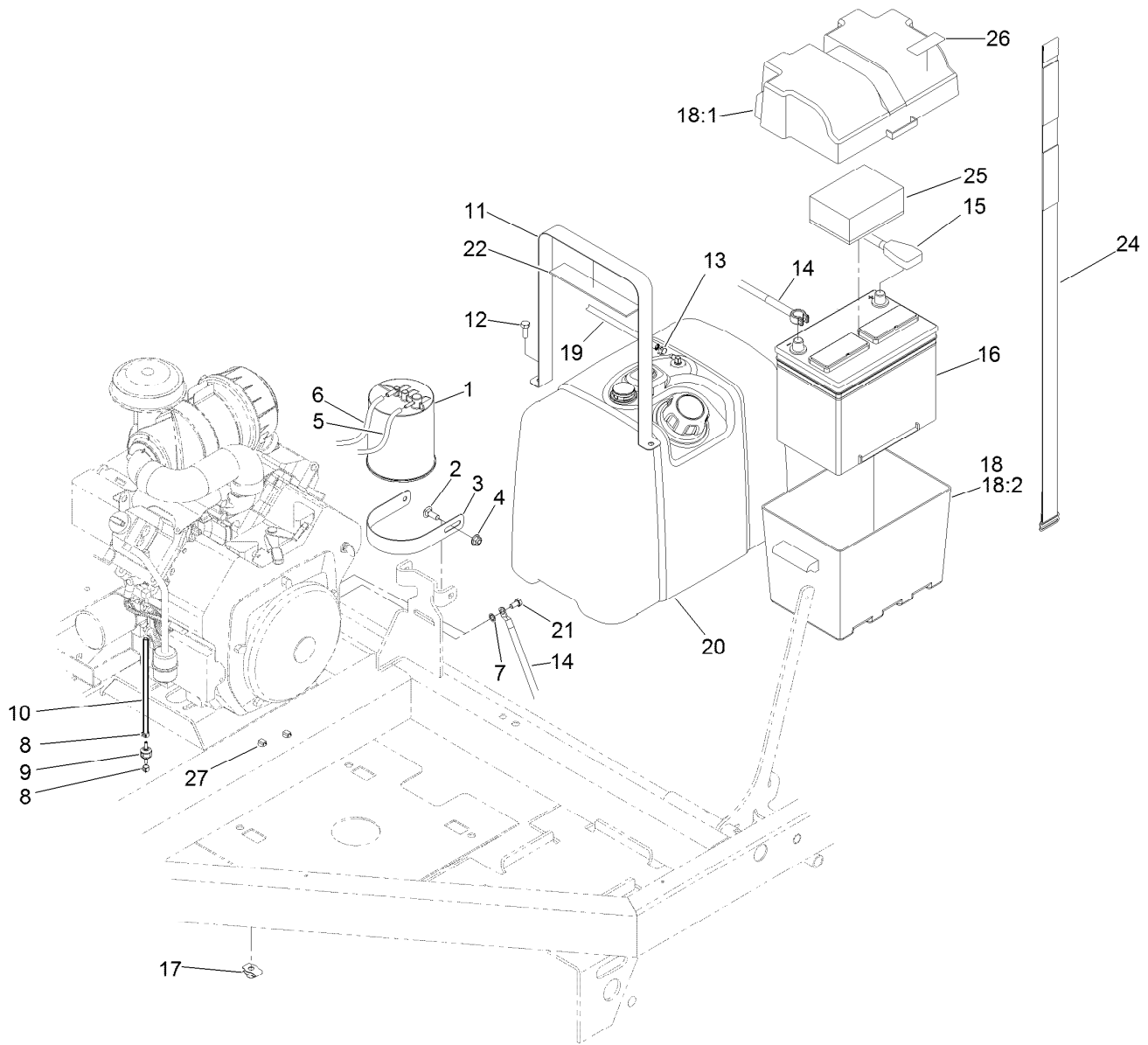

## Battery and Fuel System Assembly

<i>Ref.</i>	<i>Part Number</i>	<i>Qty.</i>	<i>Description</i>	<i>Ref.</i>	<i>Part Number</i>	<i>Qty.</i>	<i>Description</i>
1	114-0289	1	Canister-Carbon	15	112-6808	1	Cable-Battery, Positive
2	3231-2	2	Bolt-CARR	16	106-5190	1	Battery
3	117-8399	1	Strap-Mounting	17	105-4886	4	Nut-Tinnerman
4	104-8301	2	Nut-HF, NI	18	93-7595	1	Battery Box ASM
5	110-3254	1	Hose-Fuel	18:1	105-2914	1	Top-Battery Box
6	68-3630	1	Hose-Fuel	18:2	105-2915	1	Bottom-Battery Box
7	3254-2	1	Washer-Lock, Internal	19	109-1395	1	Hose-Fuel
8	2412-80	2	Clamp-Hose	20	115-9047	1	Fuel Tank ASM
9	115-7868	1	Valve-Check, Vacuum	21	33114-016	1	Screw-HH
10	115-7871	1	Hose-Fuel	22	104-7102	2	Pad-Battery
11	119-2965	2	Strap-Tank	24	94-1445	1	Strap-Battery
12	323-6	4	Screw-HH	25	93-7968	1	Pad-Foam
13	2412-98	2	Clamp-Hose	26	119-6807	1	Decal-Warning, Do Not Step
14	120-5908	1	Cable-Battery, Negative	27	32180-030	4	Clip-Tie

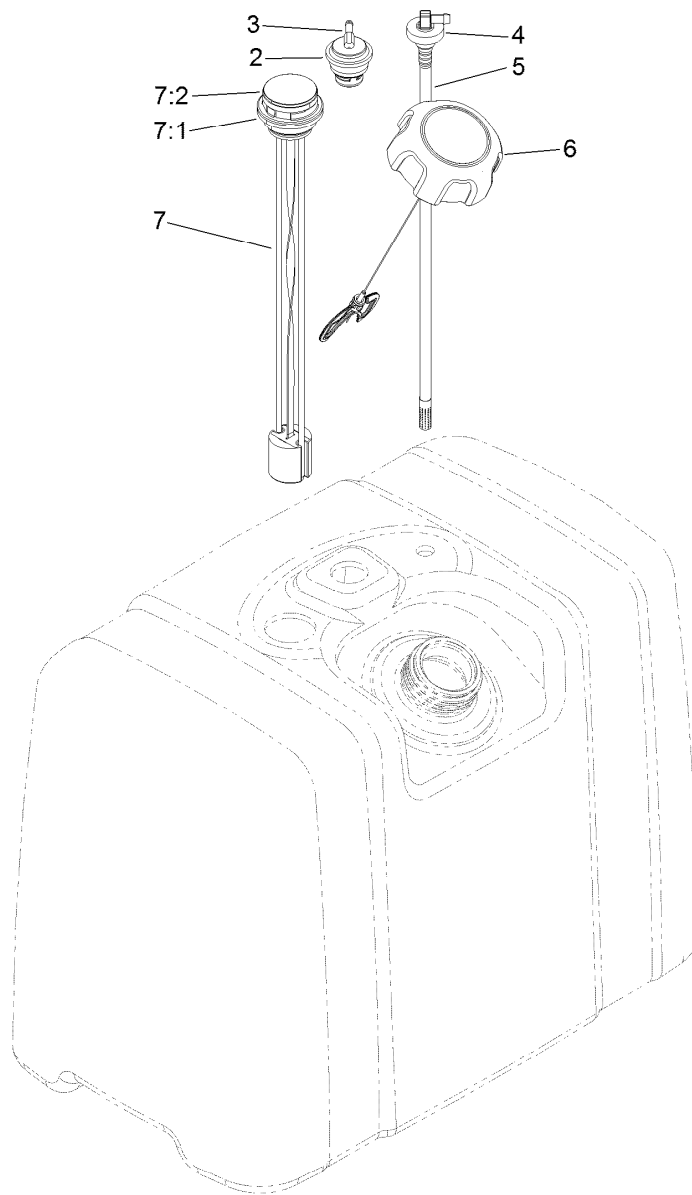

## Fuel Tank Assembly No. 115-9047

<i>Ref.</i>	<i>Part Number</i>	<i>Qty.</i>	<i>Description</i>
2	114-0284	1	Grommet
3	114-0285	1	Valve-Rollover
4	46-6560	1	Bushing
5	115-9046	1	Stand Pipe
6	115-7788	1	Cap-Fuel
7	119-0507	1	Gauge-Fuel
7:1	119-0508	1	Seal
7:2	117-8404	1	Dial-Gauge

# Hopper Assembly

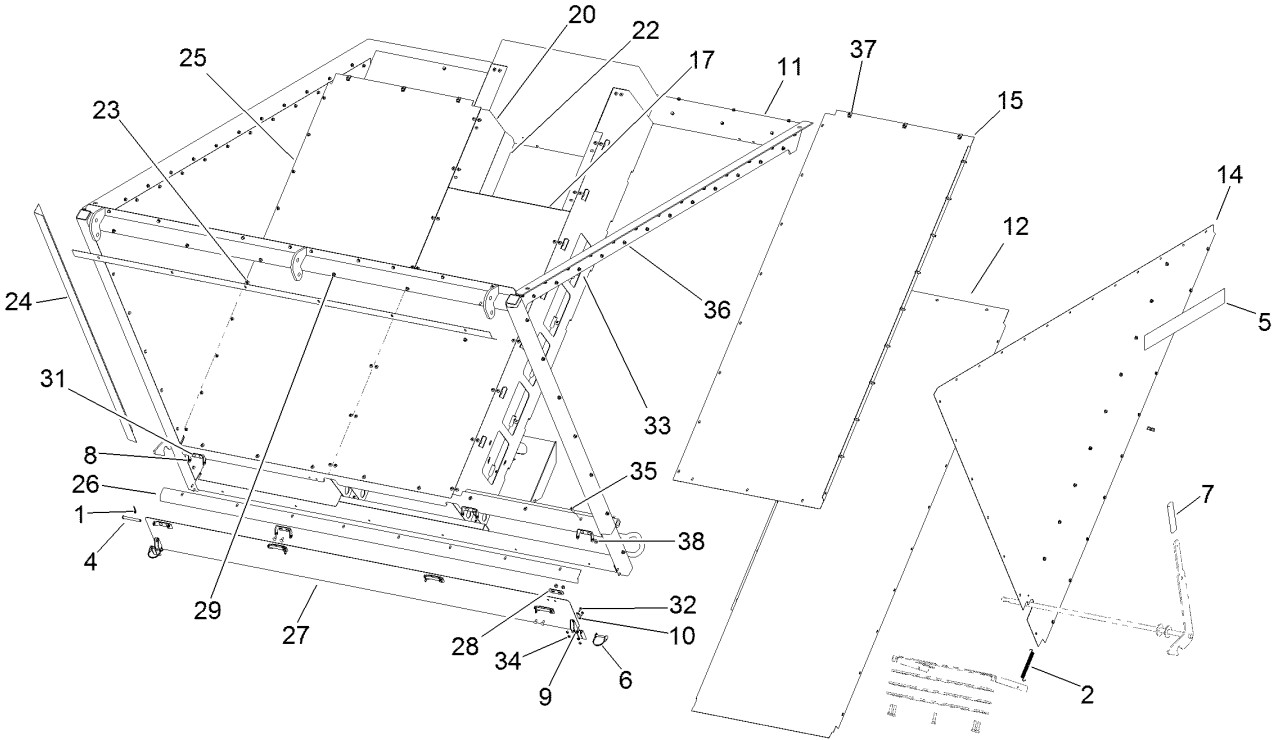
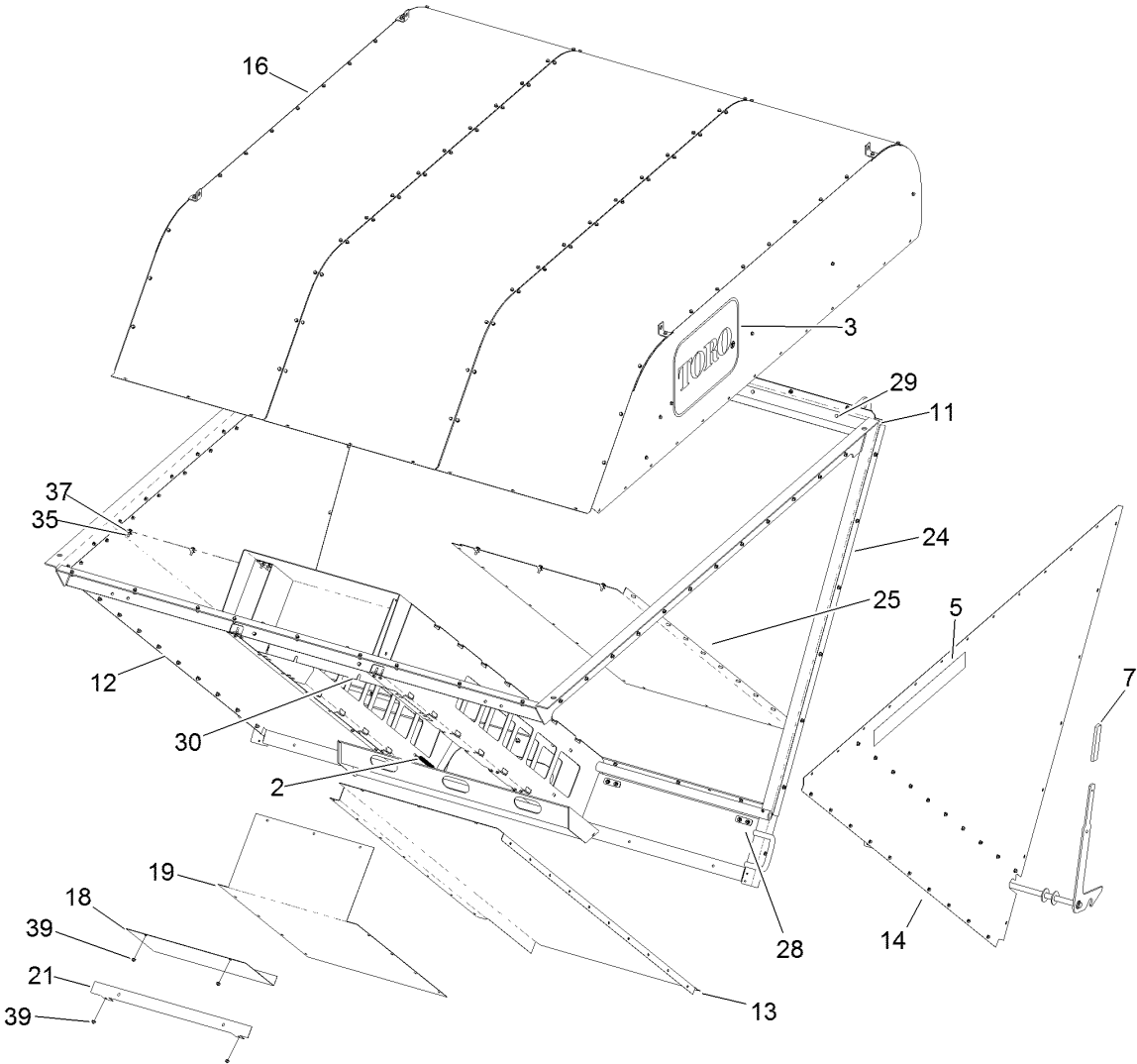

## Hopper Assembly (continued)

<i>Ref.</i>	<i>Part Number</i>	<i>Qty.</i>	<i>Description</i>	<i>Ref.</i>	<i>Part Number</i>	<i>Qty.</i>	<i>Description</i>
1	9335044	4	Pin-Hair	20	120-6164-01	2	Panel-Closeoff
2	12-8810	2	Spring-Extension	21	120-6166-01	1	Panel-Upper Closeoff
3	67-7920	2	Decal	22	120-6167-01	2	Seal-Chute, Side
4	80-2570	4	Pin-Clevis	23	120-6168-01	1	Seal-Door, Top
5	93-0184	2	Decal-Hopper	24	121-2877	2	Seal-Door, Side
6	100-1663	2	Pin-Hitch	25	120-6173	1	Panel-Floor, LH Side
7	105-3450	2	Grip-Lever, Lift	26	121-2767-01	1	Seal-Door, Bottom
8	107-1549	8	Hinge-Half	27	121-2768-01	1	Screen, Floor
9	119-6227	4	Bracket-Attachment, Chute Extension	28	121-2769	4	Plate-Hinge Backing
10	119-6230	2	Mount-Nozzle	29	321-15	20	Screw-HH
11	120-6150	1	Hopper Frame ASM	30	321-8	12	Screw-HH
12	120-6156-01	1	Panel-Bottom, RH	31	3229-11	16	Screw-CARR
13	120-6157-01	1	Panel-Bottom, LH	32	3229-34	8	Screw-CARR
14	120-6158-01	2	Panel-Side	33	3234-33	121	Screw-HHF
15	120-6159	1	Panel-Floor, RH Side	34	3296-2	8	Nut-Lock, NI
16	120-6160	1	Hopper Roof ASM	35	32105-32	53	Screw-TTH
17	120-6161	1	Panel-Center, Inside	36	32128-32	151	Nut-HHF
18	120-6162-01	1	Panel-Housing, Upper	37	107069	9	Clip
19	120-6163-01	1	Panel-Center, Lower	38	32128-33	8	Nut-HF
				39	104-7201	6	Nut-HF

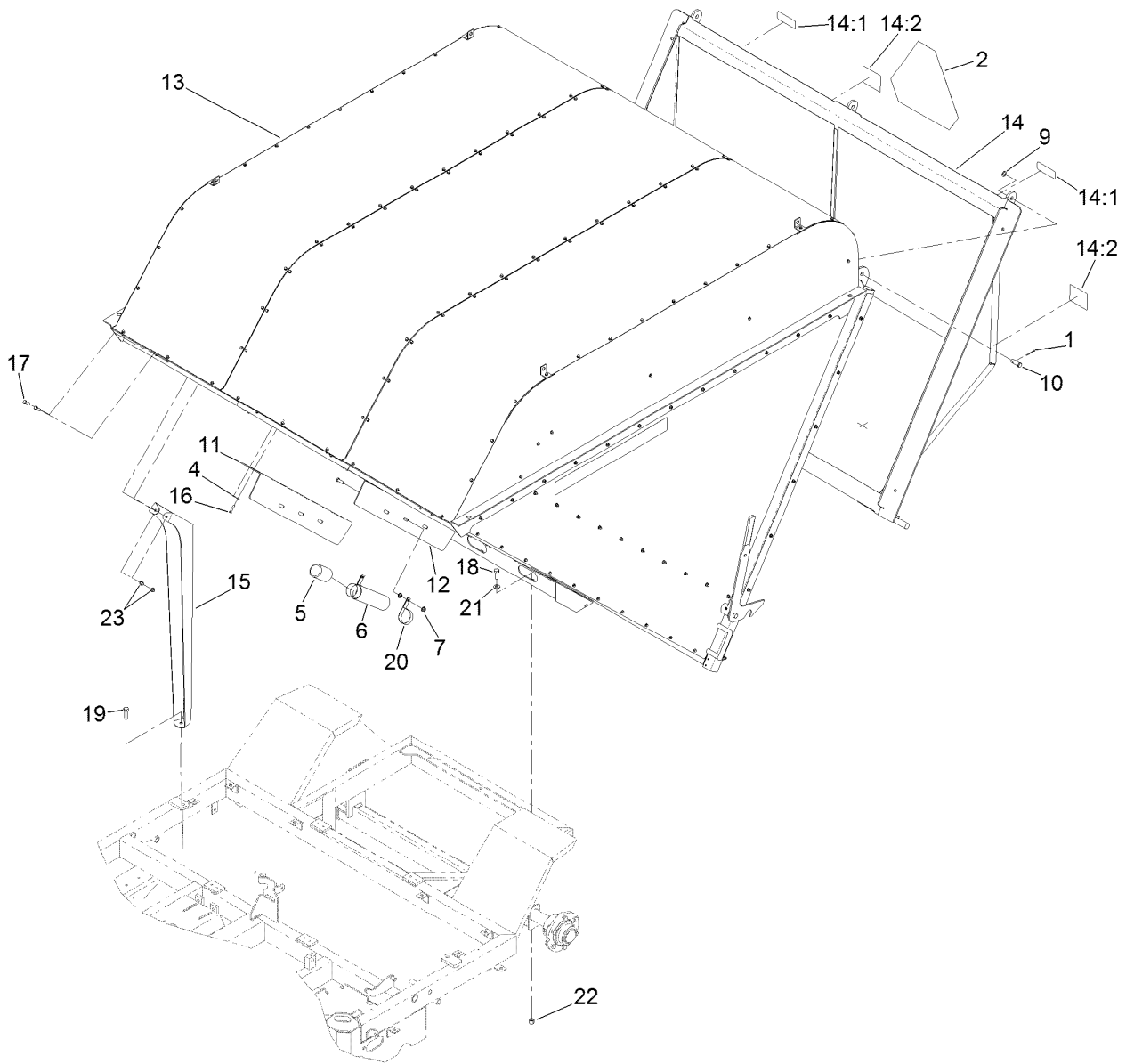

## Hopper and Hood Assembly

Ref.	Part Number	Qty.	Description	Ref.	Part Number	Qty.	Description
1	1-806800	3	Pin-Cotter	14:1	121-2840	2	Decal-Caution
2	13-2930	1	Decal	14:2	121-2841	2	Decal-Warning
4	100-2400	16	Washer	15	121-2654-01	2	Support-Hopper
5	104-7048	1	Cap-Housing	16	321-8	16	Screw-HH
6	104-7050	1	Tube-Manual	17	323-7	10	Screw-HH
7	104-8301	8	Nut-HF, NI	18	325-6	3	Screw-HH
9	107-3041	3	Washer-Flat	19	325-7	2	Screw-HH
10	119-6242	3	Pin-Hinge	20	2412-133	2	Clamp-R
11	120-6141-01	1	Bracket-Blower, RH	21	3256-26	3	Washer-Flat
12	120-6142-01	1	Bracket-Blower, LH	22	3296-23	5	Nut-Lock, NI
13	120-6170	1	Hopper ASM	23	104-8301	4	Nut-HF, NI
14	120-6175	1	Door-Hopper				



**Notes:**

**Notes:**

**Notes:**



**Count on it.**