



ProLine  
**60" MOWER**

for OUT FRONT Z  
TRACTION UNIT

Model No. 78478- 890220 & Up

---

# Operator's Manual

**IMPORTANT:** Read this manual carefully. It contains information about your safety and the safety of others. Also become familiar with the controls and their proper use before you operate the product.

# Introduction

We want you to be completely satisfied with your new product, so feel free to contact your local Authorized Service Dealer for help with service, genuine replacement parts, or other information you may require.

Whenever you contact your Authorized Service Dealer or the factory, always know the model and serial numbers of your product. These numbers will help the Service Dealer or Service Representative provide exact information about your specific product. You will find the model and serial number plate located in a unique place on the product as shown below.

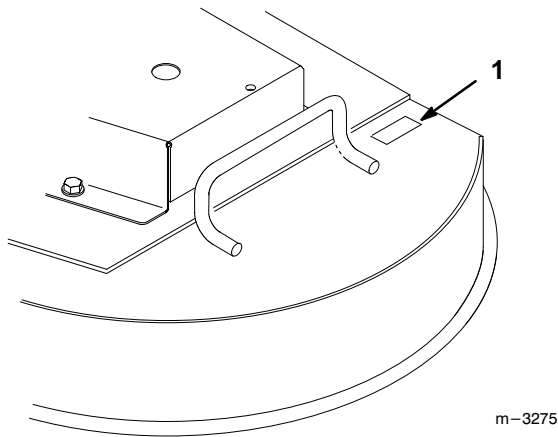

1. Model and Serial Number Plate

For your convenience, write the product model and serial numbers in the space below.

<b>Model No:</b> _____
<b>Serial No.</b> _____

The warning system in this manual identifies potential hazards and has special safety messages that help you and others avoid personal injury, even death. DANGER, WARNING and CAUTION are signal words used to identify the level of hazard. However, regardless of the hazard, be extremely careful.

**DANGER** signals an extreme hazard that will cause serious injury or death if the recommended precautions are not followed.

**WARNING** signals a hazard that may cause serious injury or death if the recommended precautions are not followed.

**CAUTION** signals a hazard that may cause minor or moderate injury if the recommended precautions are not followed.

Two other words are also used to highlight information. “Important” calls attention to special mechanical information and “Note” emphasizes general information worthy of special attention.

The left and right side of the machine is determined by sitting on the seat in the normal operator’s position.

# Contents

	<b>Page</b>		<b>Page</b>
Safety and Instruction Decals .....	2	Maintenance .....	13
Installation .....	3	Service Interval Chart .....	13
Loose Parts .....	3	Cutting Blades .....	13
Remove Carrier Frame .....	4	Correcting Cutting Unit Mismatch .....	16
Install Grass Deflector .....	4	Setting the Front-to-Rear Pitch .....	16
Install Castor Wheels .....	5	Setting the Side-to-Side Leveling .....	17
Installing Push Arms .....	5	Greasing and Lubrication .....	18
Installing Lift Springs .....	5	Replacing the Deck Belt .....	19
Reverse Gage Wheels .....	6	Replacing Blade Spindle and Bearings ...	20
Installing Mower .....	6	Replacing the Castor Wheel Fork Bushings	21
Removing the Mower .....	8	Servicing the Castor Wheels and Bearings	22
Operation .....	10	Replacing Push Arm Bushings .....	23
Operating the Power Take Off (PTO) ....	10	Replacing the Grass Deflector .....	24
Adjusting Height-of-Cut .....	11	Storage .....	24
Adjusting Gage Wheels .....	11	Troubleshooting .....	25
Tilting the Mower .....	12		

# Safety and Instruction Decals



Safety decals and instructions are easily visible to the operator and are located near any area of potential danger. Replace any decal that is damaged or lost.

(2) ON BOTH SIDES OF CUTTING UNIT  
(Part No. 66-1340)



UNDER DEFLECTOR  
(Part No. 66-6380)



ON DEFLECTOR  
(Part No. 93-1122)



(2) NEXT TO SPRING  
MOUNTS  
(Part No. 55-4300)



ON CENTER OF DECK,  
UNDER FOOTREST  
(Part No. 68-8340)



(3) NEXT TO EACH  
BLADE SPINDLE  
(Part No. 88-8950)



ON LEFT SIDE OF  
CUTTING UNIT  
(Part No. 68-3380)

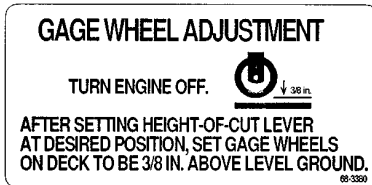

NEXT TO GEARBOX,  
UNDER FOOTREST  
(Part No. 70-2560)



ON SIDES OF CARRIER FRAME  
(Part No. 94-9585), Right Side  
(Part No. 94-9586), Left Side

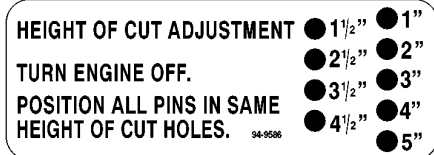

ON CENTER OF DECK,  
UNDER FOOTREST  
(Part No. 94-9547)

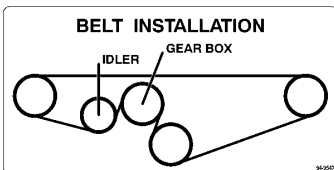

ON DRIVE SHAFT COVER  
(Part No. 98-1305)



ON FOOTREST  
(Part No. 98-1304)

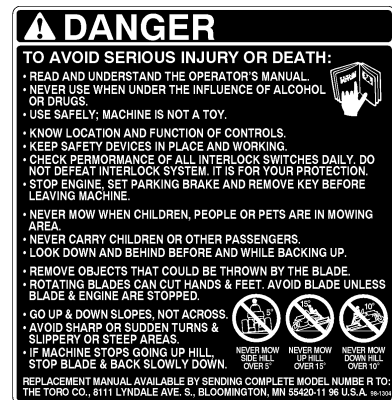

# Installation

## Loose Parts

**Note:** Use the chart below to identify parts used for assembly.

DESCRIPTION	QTY.	USE
Castor Wheel	2	Install castor wheels to carrier frame
Thrust Washer	8	
Retaining Ring	2	
Deflector	1	Install deflector to mower
Bolt 3/8–16 x 3-3/4" (95 mm)	2	
Spring	2	
Locknut 3/8–16	2	
Push Arms	2	Install push arms to carrier frame
Flat Washer 1-1/2" O.D. (38 mm)	2	
Retaining Ring	2	
Spring Assembly	2	Install springs to carrier frame
Shoulder Bolt 3/8"–16 x 7/8" (22 mm)	2	
Locknut 3/8"–16	2	
Shoulder Bolt 3/8"–16 x 7/8" (22 mm)	2	Install mower to traction unit
Locknut 3/8"–16	2	
Operator's Manual	1	Read before operating
Parts Catalog	1	Ordering parts

## Remove Carrier Frame

1. Remove hairpin cotters and clevis pins from mower hanger brackets and remove mower from carrier frame (Fig. 1).

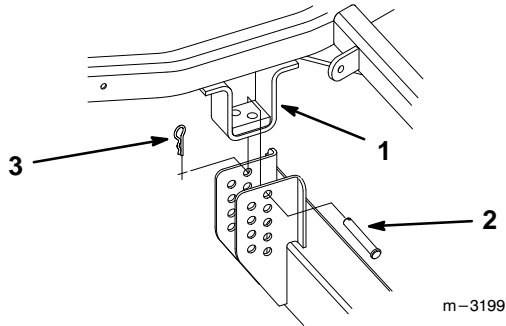

Figure 1

- |                         |                   |
|-------------------------|-------------------|
| 1. Mower Hanger Bracket | 3. Hairpin Cotter |
| 2. Clevis Pin           |                   |

### DANGER

#### POTENTIAL HAZARD

- Without the grass deflector, discharge cover, or complete grass catcher assembly mounted in place, you and others are exposed to blade contact and thrown debris.

#### WHAT CAN HAPPEN

- Contact with rotating mower blade(s) and thrown debris will cause injury or death.

#### HOW TO AVOID THE HAZARD

- NEVER remove the grass deflector from the mower because the grass deflector routes material down toward the turf. If the grass deflector is ever damaged, replace it immediately.
- Never put your hands or feet under the mower.
- Never try to clear discharge area or mower blades unless you move the power take off (PTO) to "OFF" and rotate the ignition key to "OFF." Also remove the key and pull the wire off the spark plug(s).

## Install Grass Deflector

1. Locate the deflector mounts over the pivot brackets and secure with the (2) 3/8–3-3/4" (95 mm) bolts, (2) springs and (2) 3/8" locknuts. Make sure the straight ends of the springs are positioned between the deflector mounts and the grass deflector (Fig. 2).
2. Tighten the locknuts until they contact the pivot brackets (Fig. 2).

**IMPORTANT: The grass deflector must be spring-loaded in the down position. Lift the deflector up to test that it snaps to the full down position.**

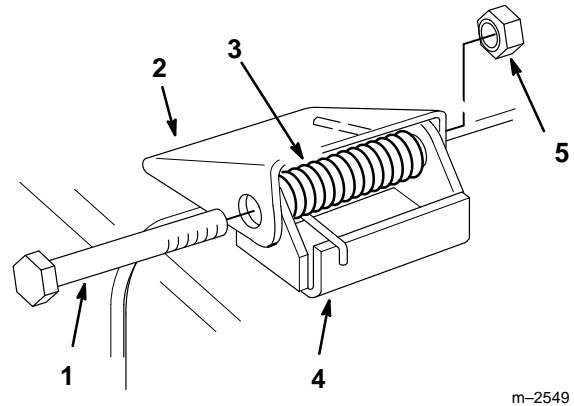

Figure 2

- |                                 |                  |
|---------------------------------|------------------|
| 1. Bolt 3/8–24 x 3-3/4" (95 mm) | 3. Spring        |
| 2. Deflector Mount              | 4. Pivot Bracket |
|                                 | 5. Locknut 3/8"  |

## Install Castor Wheels

1. Place (1) thrust washer on shaft and slide the castor wheel into the mounting tube (Fig. 3).
2. Place (3) thrust washers on top of shaft and secure with retaining ring (Fig. 3).

**Note:** The location of the thrust washers on each fork may need adjustment to maintain a level deck.

3. Grease the fitting on the carrier frame mounting tube using No. 2 general purpose lithium base or molybdenum base grease, refer to: Greasing and Lubrication.
4. Set the castor wheel tire pressure to 50 psi (345 kPa).

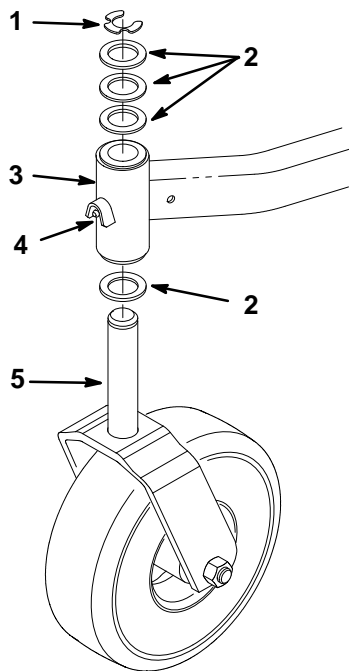

m-3191

**Figure 3**

- |                                |                      |
|--------------------------------|----------------------|
| 1. Retaining ring              | 4. Grease fitting    |
| 2. Thrust Washer (4)           | 5. Castor Wheel Fork |
| 3. Carrier Frame Mounting Tube |                      |

## Installing Push Arms

1. Place push arm onto carrier frame pin as shown (Fig. 4).
2. Secure with 1-1/2" (38 mm) flat washer and retaining ring (Fig. 4).

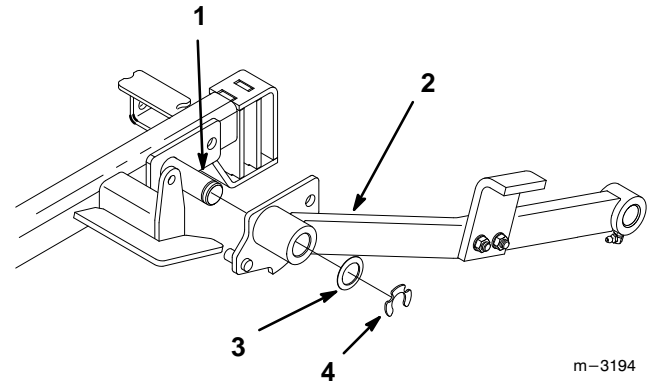

m-3194

**Figure 4**

- |             |                               |
|-------------|-------------------------------|
| 1. Pin      | 3. Flat washer 1-1/2" (38 mm) |
| 2. Push arm | 4. Retaining ring             |

## Installing Lift Springs

1. Secure spring end plate assembly to traction unit with 3/8" x 7/8" (23 mm) shoulder bolt and 3/8" locknut (Fig. 5).

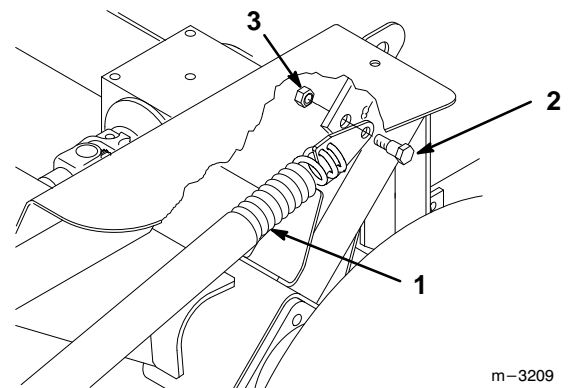

m-3209

**Figure 5**

- |                                      |                 |
|--------------------------------------|-----------------|
| 1. Spring Assembly                   | 3. Locknut 3/8" |
| 2. Shoulder Bolt 3/8" x 7/8" (22 mm) |                 |

## Reverse Gage Wheels

1. Remove hairpin cotter and pin to remove gage wheel from on mower mount (Fig. 6). Slide gage wheel out of mount and reverse location.
2. Select a hole position so the gage wheel is 3/8" (9.5 mm) off the ground for the height-of-cut to be used (Fig. 6).
3. Insert pin and secure with hairpin cotter.
4. Repeat adjustment on other gage wheel(s).

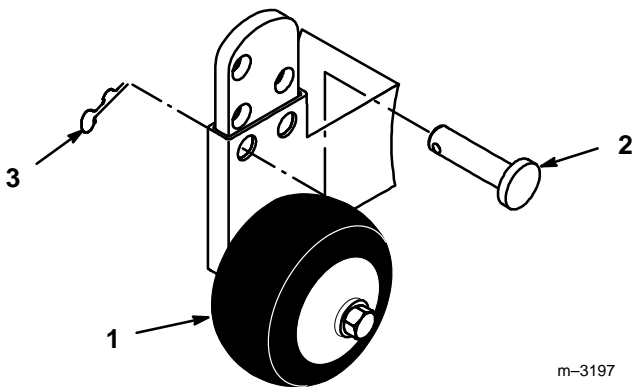

**Figure 6**

1. Wheel
2. Pin
3. Hair pin Cotter

m-3197

## Installing Mower

1. Position carrier frame in front of traction unit and place push arms into clevises (Fig. 7).
2. Retain push arms with pivot pin assemblies, aligned with flat against frame, and secure with hairpin cottes (Fig. 7).

**Note:** Pivot pin assemblies and hairpin cottes are part of traction unit.

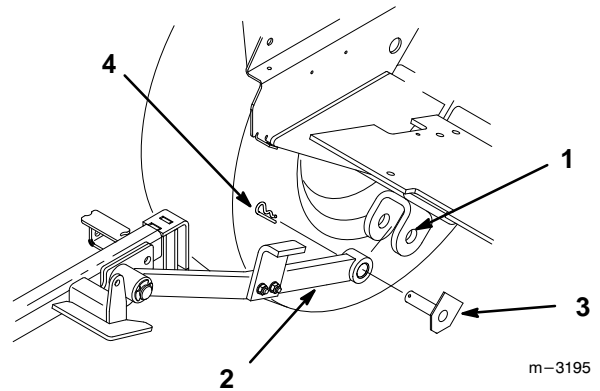
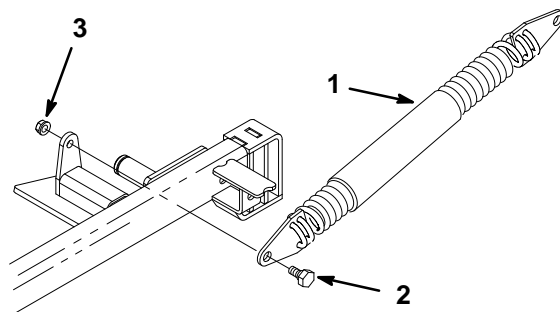

**Figure 7**

1. Clevis
2. Push Arm
3. Pivot Pin Assembly-flat
4. Hairpin Cotter

m-3195

3. Lift carrier frame into vertical position, refer to: Tilting the Mower.
4. Secure spring end plate assembly to carrier frame with 3/8" x 7/8" (23 mm) shoulder bolt and 3/8" locknut (Fig. 8).



**Figure 8**

1. Spring Assembly
2. Shoulder Bolt 3/8" x 7/8" (22 mm)
3. Locknut 3/8"

m-3193

5. Roll mower in front of traction unit.
6. Rotate PTO drive shaft so holes in universal joint align with hole in gearbox shaft and slide together (Fig. 9).
7. Drive roll pin through hole in universal joint to secure PTO drive shaft to gearbox shaft (Fig. 9).

**Note:** Drive shaft and roll pin are part of traction unit.

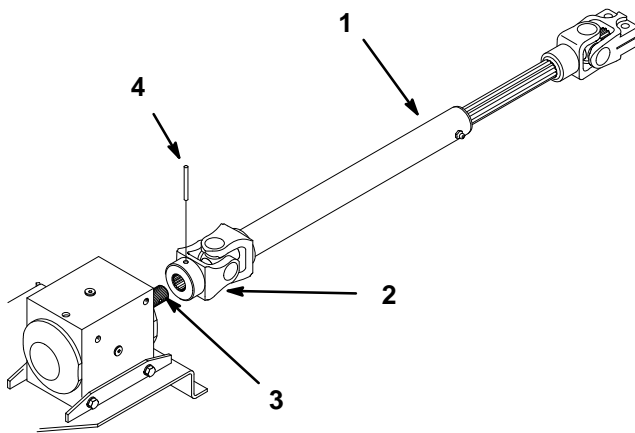

m-3196

**Figure 9**

- |                    |                  |
|--------------------|------------------|
| 1. PTO Driveshaft  | 3. Gearbox shaft |
| 2. Universal Joint | 4. Roll Pin      |

8. Release the latch levers and push carrier frame down. Latch pins should lock.
9. Select hole in mower hanger bracket corresponding to the height-of-cut desired. Lift on side and front handles to align holes and insert clevis pin (Fig. 10).
10. Secure clevis pin with hairpin cotter (Fig. 10).

**Note:** All four clevis pins should be in the same hole location for a level cut.

**HEIGHT OF CUT ADJUSTMENT**

● 1 1/2"	● 1"
● 2 1/2"	● 2"
● 3 1/2"	● 3"
● 4 1/2"	● 4"
● 5"	● 5"

**TURN ENGINE OFF.**

**POSITION ALL PINS IN SAME HEIGHT OF CUT HOLES.**

94-9086

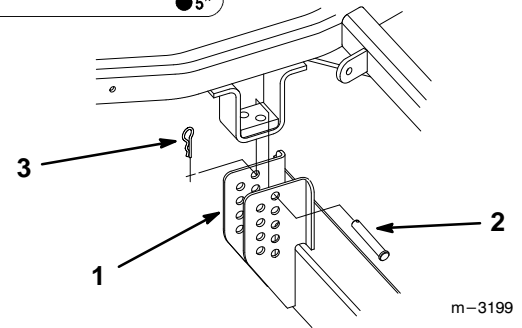

m-3199

**Figure 10**

- |                         |                   |
|-------------------------|-------------------|
| 1. Mower Hanger Bracket | 3. Hairpin Cotter |
| 2. Clevis Pin           |                   |

## Removing the Mower

1. Drive roll pin through hole in universal joint to remove PTO drive shaft from gearbox shaft (Fig. 9).

**Note:** Roll pin and drive shaft remain with traction unit.

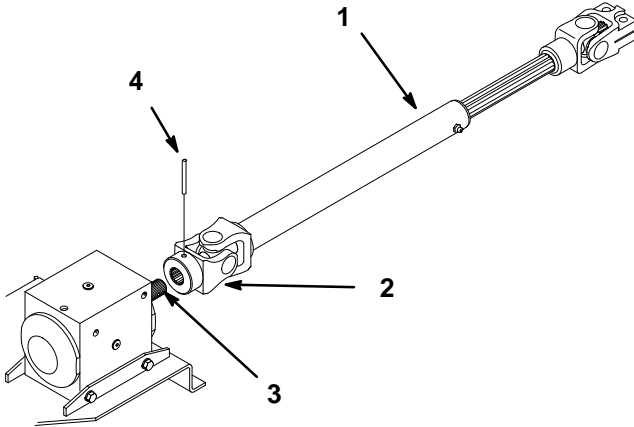

m-3196

**Figure 11**

- |                    |                  |
|--------------------|------------------|
| 1. PTO Driveshaft  | 3. Gearbox shaft |
| 2. Universal Joint | 4. Roll Pin      |

2. Tilt mower into raised position, refer to: Tilting the Mower.
3. Remove 3/8" x 7/8" (23 mm) shoulder bolt and 3/8" locknut securing spring end plate assembly to carrier frame (Fig. 12).

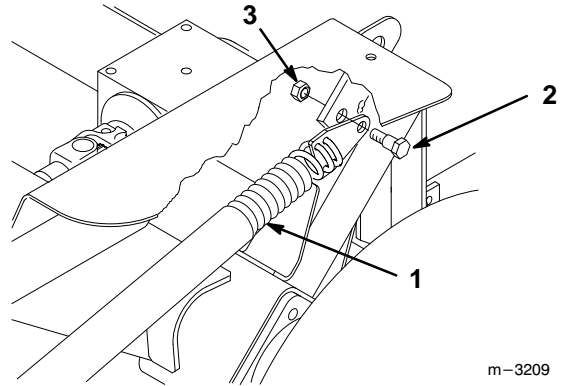

m-3209

**Figure 12**

- |   |                 |
|---|-----------------|
| 1. Spring Assembly                      | 3. Locknut 3/8" |
| 2. Shoulder Bolt 3/8" x 7/8"<br>(22 mm) |                 |

4. Carefully lower mower from vertical position using front lift handles, refer to: Tilting the Mower.
5. Remove hairpin cotters and clevis pins from mower hanger brackets and remove mower from carrier frame (Fig. 13).

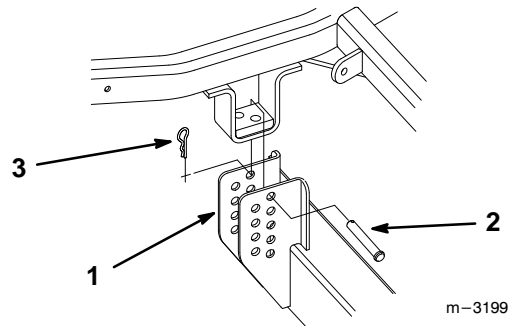

m-3199

**Figure 13**

- |                         |                   |
|-------------------------|-------------------|
| 1. Mower Hanger Bracket | 3. Hairpin Cotter |
| 2. Clevis Pin           |                   |

6. Raise the carrier frame and roll the mower away from traction unit.
7. Lower carrier frame and remove hairpin cotters and pivot pin assemblies securing push arms to traction unit clevises (Fig. 14).

**Note:** Save all hardware for use when installing mower.

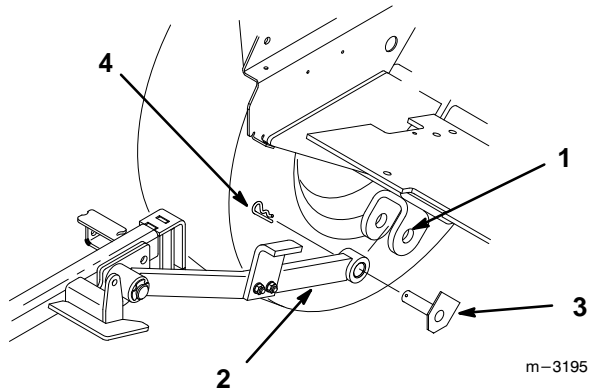
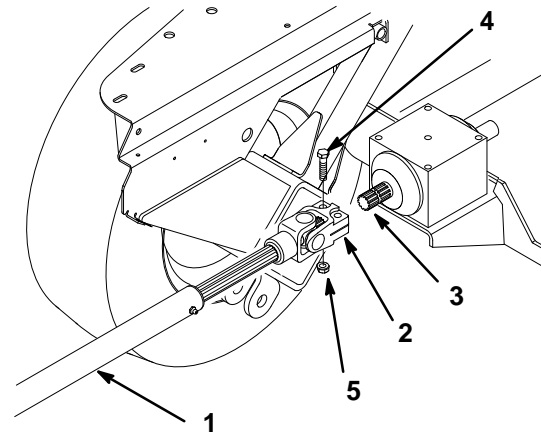

**Figure 14**

- |             |                            |
|-------------|----------------------------|
| 1. Clevis   | 3. Pivot Pin Assembly—flat |
| 2. Push Arm | 4. Hairpin Cotter          |

8. Remove (2) 3/8”–16 x 1-5/8” (41.5 mm) bolts and 3/8”–16 locknuts from universal joint and slide the driveshaft off gearbox shaft (Fig. 15).

**Note:** Save all hardware for use when installing mower.



**Figure 15**

- |                    |                                    |
|--------------------|------------------------------------|
| 1. PTO Driveshaft  | 4. Bolt 3/8”–16 x 1-5/8” (41.5 MM) |
| 2. Universal Joint | 5. Locknut 3/8”–16                 |
| 3. Gearbox shaft   |                                    |

# Operation

## Operating the Power Take Off (PTO)

The power take off (PTO) switch engages and disengages power to the electric clutch.

### Engaging the PTO

1. Release pressure on the traction control levers and place in neutral (Fig. 16).
2. Release the parking brake (Fig. 16).

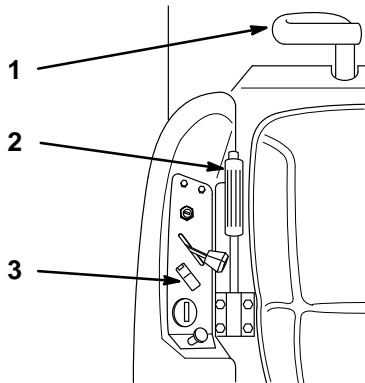

m-3180

**Figure 16**

1. Traction control lever
2. Parking brake
3. PTO-Switch

3. To engage lift cover and move the PTO switch to the "ON" position (Fig. 17).

### Disengaging the PTO

1. Closing the cover moves the PTO switch to the "OFF" position (Fig. 17).

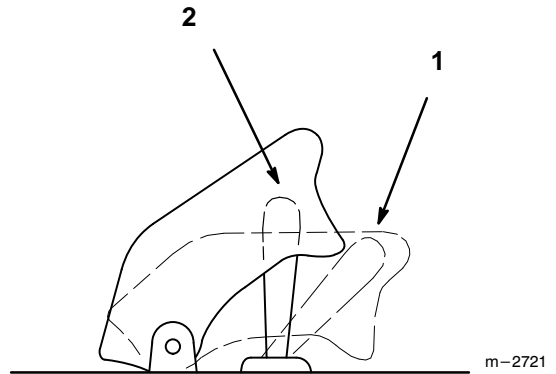

m-2721

**Figure 17**

1. PTO-Off
2. PTO-On

## Adjusting Height-of-Cut

The height-of-cut is adjusted from 1" to 5" (25 to 127 mm) in 1/2" (13 mm) increments by relocating four clevis pins in different hole locations.

1. To adjust, remove hairpin cotter and clevis pin from mower hanger bracket (Fig. 18).
2. Select hole in mower hanger bracket corresponding to the height-of-cut desired. Lift on side and front handles to align holes and insert clevis pin (Fig. 18).
3. Secure clevis pin with hairpin cotter (Fig. 18).

**Note:** All four clevis pins should be in the same hole location for a level cut.

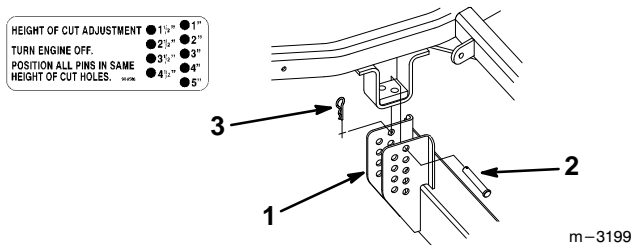

Figure 18

1. Mower Hanger Bracket
2. Clevis Pin
3. Hairpin Cotter

4. When using 1" (25 mm) height-of-cut front and rear rollers must be removed (Fig. 19).

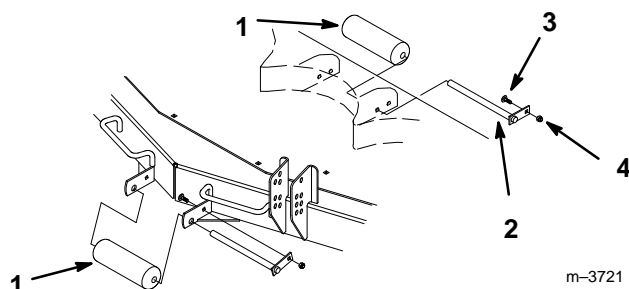

Figure 19

1. Roller
2. Rod
3. Bolt
4. Locknut

## Adjusting Gage Wheels

The gage wheels must be adjusted in the proper hole location for each height-of-cut position.

1. After adjusting height-of-cut, raise the attachment lift lever: Refer to Raising Attachments.
2. Remove hairpin cotter and pin to change hole location (Fig. 20).
3. Select a hole position so the gage wheel is 3/8" (9.5 mm) off the ground for the height-of-cut to be used (Fig. 20).
4. Insert pin and secure with hairpin cotter.
5. Repeat adjustment on other gage wheel.

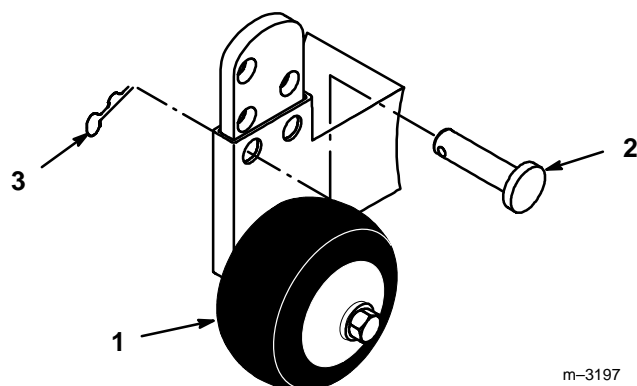

Figure 20

1. Wheel
2. Pin
3. Hair pin Cotter

## Tilting the Mower

The mower can be tilted up for ease of service or to shorten unit length for transport and storage.

### To Raise Mower

1. Set the parking brake and check that PTO cover is down against footrest (Fig. 16).
2. Lift on side handle to release weight on latch pin and pull out on latch pin to release (Fig. 21). Lower rear of mower onto anti-scalp rollers. Repeat on the other side.

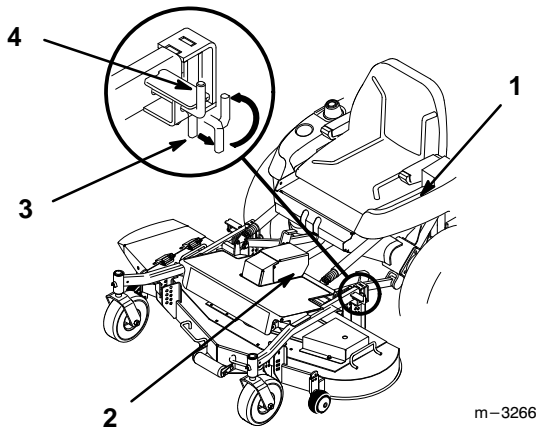

Figure 21

- |                  |               |
|------------------|---------------|
| 1. Parking brake | 3. Latch pin  |
| 2. PTO cover     | 4. Notch—open |

3. Standing in front of the mower, lift up and push rearward on front handles to raise mower (Fig. 22). Raise mower until it contacts stops and latch pins snap into locked position.

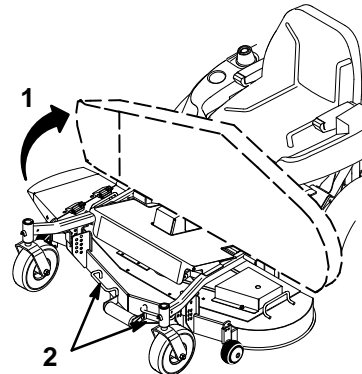

Figure 22

- |             |                 |
|-------------|-----------------|
| 1. Mower up | 2. Lift handles |
|-------------|-----------------|

### To Lower Mower

1. Pull out latch pins and rotate into notch to hold in the open position (Fig. 21). Standing in front of the mower, pull forward on front handles and lower mower (Fig. 22).
2. Rotate latch pins into released position and lift on side handles of mower until latch pins engage (Fig. 21). Repeat on the other side.

# Maintenance

## Service Interval Chart

Service Operation	Each Use	8 Hours	25 Hours	Storage Service	Notes
Cutting Blades – check		X		X	
Belts – check for wear/cracks				X	
Blade Spindle Bearings – grease		X			
Castor Wheels – grease			X		
Gear box – check			X		
Mower Housing – clean	X	X		X	
Chipped Surfaces – paint				X	

For ease of maintenance and service the mower can be tilted up, refer to: Tilting the Mower, in the Operation section for instructions.

## Cutting Blades

To ensure a superior quality of cut, keep the blades sharp. For convenient sharpening and replacement, you may want to keep extra blades on hand.

## Before Inspecting or Servicing the Blades

Park the machine on a level surface, disengage the blade control (PTO) and set the parking brake. Turn the ignition key to “OFF” to stop the engine. Remove the key and disconnect the spark plug wire(s) from the spark plug(s).

### WARNING

#### POTENTIAL HAZARD

- A blade that is worn or damaged could break apart and pieces could be thrown at bystanders or at you as you use the mower.

#### WHAT CAN HAPPEN

- Pieces of blade that may be thrown could seriously injure or kill you or bystanders.

#### HOW TO AVOID THE HAZARD

- Periodically inspect the blade for wear and damage. Immediately install a new blade if it is worn or damaged.

## Inspecting the Blades

1. Inspect the cutting edges (Fig 23). If the edges are not sharp or have nicks, remove and sharpen the blades. Refer to Sharpening the Blades on page 15.
2. Inspect the blades, especially the curved area (Fig. 23). If you notice any damage, wear, or a slot forming in this area (item 3 in Fig. 23), immediately install a new blade.

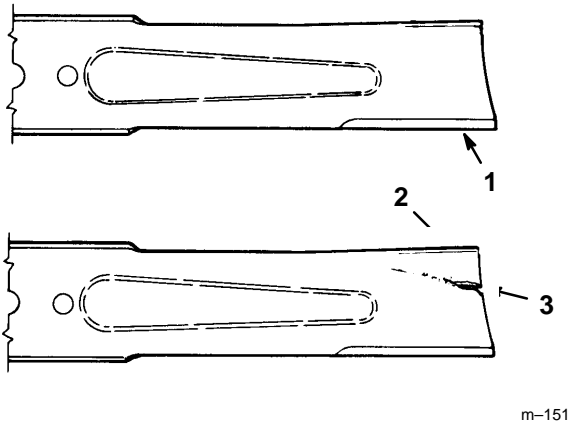
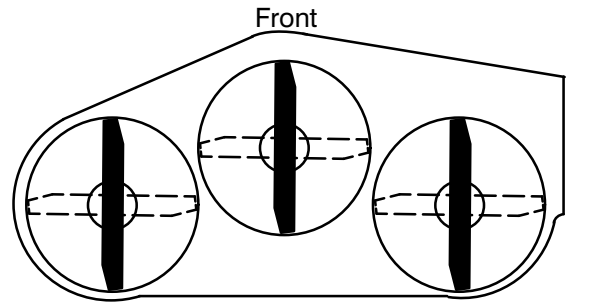

**Figure 23**

- |                 |                      |
|-----------------|----------------------|
| 1. Cutting Edge | 3. Wear/slot Forming |
| 2. Curved Area  |                      |

## Checking for Bent Blades

1. Rotate the blades until the ends face forward and backward (Fig. 24). Measure from a level surface to the cutting edge of the blades (Fig. 25). Note this dimension.
2. Rotate the opposite ends of the blades forward. Measure from a level surface to the cutting edge of the blades at the same position as in step 1 above. The difference between the dimensions obtained in steps 1 and 2 must not exceed 1/8" (3 mm). If this dimension exceeds 1/8" (3 mm), the blade is bent and must be replaced. Refer to Removing the Blades, and Installing the Blades on page 15.



**Figure 24**

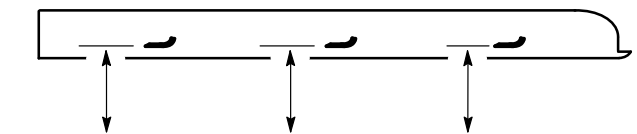

MEASURE FROM  
CUTTING EDGE TO A  
LEVEL SURFACE

m-2539

**Figure 25**

## ! WARNING

### POTENTIAL HAZARD

- A blade that is bent or damaged could break apart and pieces could be thrown at bystanders or at you as you use the mower.

### WHAT CAN HAPPEN

- Pieces of blade that may be thrown could seriously injure or kill you or bystanders.

### HOW TO AVOID THE HAZARD

- Always replace bent or damaged blade with a new blade.
- Never file or create sharp notches in the edges or surfaces of blade.

## Removing the Blades

Blades must be replaced if a solid object is hit, if the blade is out of balance or is bent. To ensure optimum performance and continued safety conformance of the machine, use genuine TORO replacement blades. Replacement blades made by other manufacturers may result in non-conformance with safety standards.

Hold the blade end using a rag or thickly-padded glove. Remove the blade bolt, washer and blade from the spindle shaft (Fig. 26).

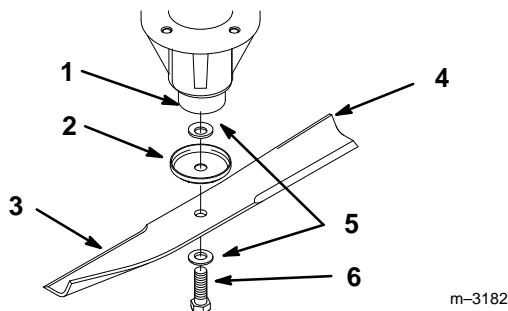

Figure 26

- |                |                       |
|----------------|-----------------------|
| 1. Spindle     | 4. Sail Area of Blade |
| 2. Spindle cup | 5. Washer             |
| 3. Blade       | 6. Blade Bolt         |

## Sharpening the Blades

1. Use a file to sharpen the cutting edge at both ends of the blade (Fig. 27). Maintain the original angle. The blade retains its balance if the same amount of material is removed from both cutting edges.



Figure 27

1. Sharpen at original angle

2. Check the balance of the blade by putting it on a blade balancer (Fig. 28). If the blade stays in a horizontal position, the blade is balanced and can be used. If the blade is not balanced, file some metal off the end of the sail area only (Fig. 26). Repeat this procedure until the blade is balanced.

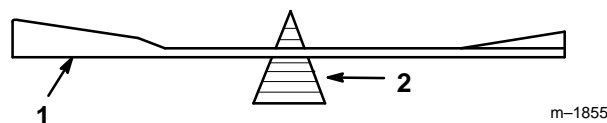

Figure 28

1. Blade
2. Balancer

## Installing the Blades

1. Install a washer, spindle cover and blade onto the spindle shaft (Fig. 26).

**IMPORTANT:** The curved part of the blade must be pointing upward toward the top of the mower to ensure proper cutting.

2. Install the washer and blade bolt (Fig. 26). Torque the blade bolt to 85–110 ft-lb (115–140 N•m).

## Correcting Cutting Unit Mismatch

If one cutter blade cuts lower than the other, correct as follows:

1. Stop the engine, remove the key and disconnect the spark plug wire(s) from the spark plug(s).
2. Adjust the tire pressure in all tires to specifications and check that the blades are not bent. Refer to Checking for Bent Blades on page 14.
3. Set the height-of-cut to the 2-1/2" position. Refer to Adjusting the Height-Of-Cut in the Operation section. Make sure the clevis pins are resting on the frame cushions.
4. Rotate the blades so the tips line up with one another. The blade tips must be within 1/8" (3 mm) of each other. If the blade tips are not within 1/8" (3 mm) of each other, add shims (Part No. 3256-24) between the appropriate spindle housing and the bottom of the cutting unit to align the blades.

## Setting the Front-to-Rear Pitch

1. Check the tire pressure.
2. Position the blades front-to-rear (Fig. 29). Measure at "C" and "D" locations (Fig. 29) from a level surface to the cutting edge of the blades (Fig. 30).
3. The mower should be 1/8"–5/8" (3–16 mm) lower in front "C" than in the rear "D".

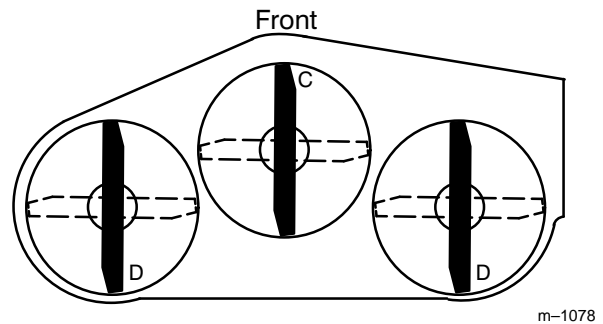

Figure 29

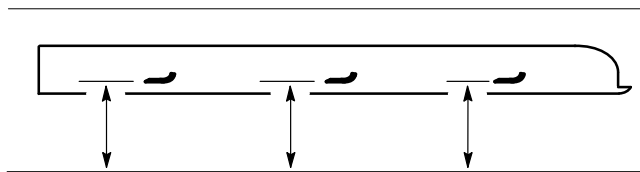

Figure 30

4. To change the front-to-rear pitch, remove the retaining ring and move an equal number of thrust washers on both castor wheel forks. Move the thrust washers from the top of the carrier frame mounting tube to the bottom to raise the front of the mower. Move the thrust washers from the bottom of the mounting tube to the top to lower the front of the mower (Fig. 40).
5. Check the side-to-side leveling of the cutting unit.

## Setting the Side-to-Side Leveling

1. Check the tire pressure.
2. Position the blades side-to-side (Fig. 31). Measure at "A" and "B" locations (Fig. 31) from a level surface to the cutting edge of blades (Fig. 32).
3. The difference between measurements "A" and "B" should be no more than 1/4" (6 mm).
4. To change the side-to-side leveling, remove the retaining ring and move the thrust washers on one castor wheel fork only. Move the thrust washers from the top of the carrier frame mounting tube to the bottom to raise the corresponding side of the mower. Move the thrust washers from the bottom of the mounting tube to the top to lower the corresponding side of the mower. (Fig. 40).
5. Recheck the front-to-rear pitch of the cutting unit.

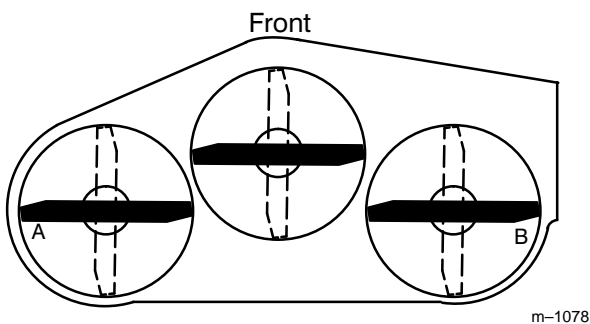
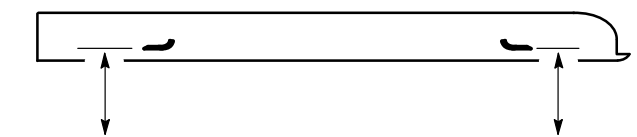

Figure 31



MEASURE FROM  
CUTTING EDGE TO A  
LEVEL SURFACE

Figure 32

## Greasing and Lubrication

The cutting unit must be lubricated regularly. Refer to the Service Interval Chart on page 13. Grease with No. 2 general purpose lithium base or molybdenum base grease.

1. Stop the engine, remove the key and disconnect the spark plug wire(s) from the spark plug(s).
2. Grease the fittings on the three spindle bearings (Fig. 33).

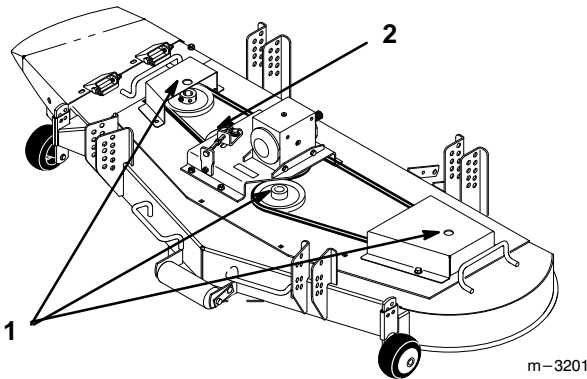

**Figure 33**

1. Spindle Bearing
2. Idler pulley

3. Grease the fittings on push arms (Fig. 34).

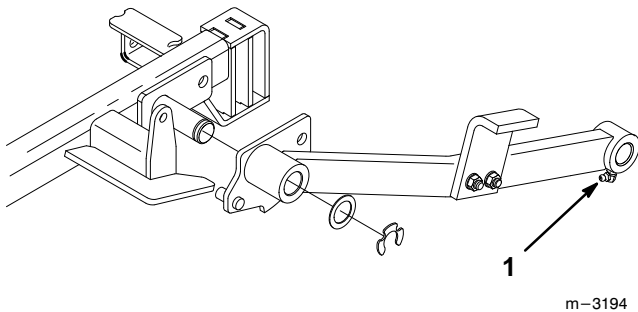

**Figure 34**

1. Push arm bearing

4. Grease the fittings on the carrier frame mounting tubes and castor wheels (Fig. 35).

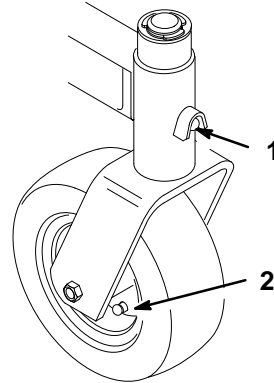

**Figure 35**

1. Carrier Frame Mounting Tube Grease Fitting
2. Castor Wheel Grease Fitting

5. Remove plug on the side of the gearbox and check the level of lubrication in the gearbox. If level is low, add SAE EP-80/90 wt. gear oil until level is up to side plug in gearbox. (Fig. 36).

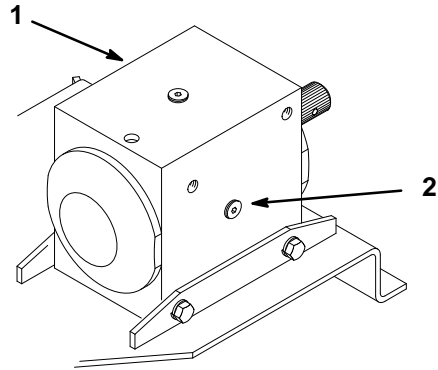

**Figure 36**

1. Gearbox
2. Side plug

## Replacing the Deck Belt

Squealing when the belt is rotating, blades slipping when cutting grass, frayed belt edges, burn marks and cracks are signs of a worn deck belt. Replace the deck belt if any of these conditions are evident.

1. Stop the engine, remove the key and disconnect the spark plug wire(s) from the spark plug(s).
2. Remove the belt covers on top of the outer blade spindles (Fig. 38).
3. Loosen the idler tension bolt and jam nuts, to relieve tension on the idler pulley, then remove the idler mounting bolt and slide idler pulley out through opening (Fig. 38). Remove worn belt.
4. Install new deck belt pulling through space behind gearbox pulley, then routing around two outboard spindle pulleys and center spindle pulley. Check that belt is in front of belt guide (Fig. 37).
5. Place idler pulley inside belt loop and slide into opening. Place flats of idler hub into slot and loosely install idler mounting bolt (Fig. 38).
6. Tighten idler tension bolt to achieve the correct dimension between brackets (Fig. 38).

**IMPORTANT: Adjust new belt to 3" (77 mm), after 5–10 hours adjust tension to 2-5/8" (67 mm).**

7. Tighten jam nuts and idler mounting bolt securely (Fig. 38).

**Note:** Light belt contact with rear of gearbox bracket is acceptable.

8. Reinstall the outer spindle covers (Fig. 38).

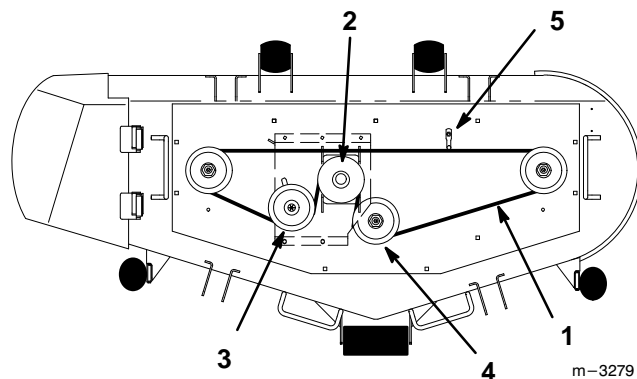

**Figure 37**

- |                   |                          |
|-------------------|--------------------------|
| 1. Deck belt      | 4. Center Spindle Pulley |
| 2. Gearbox pulley | 5. Belt guide            |
| 3. Idler pulley   |                          |

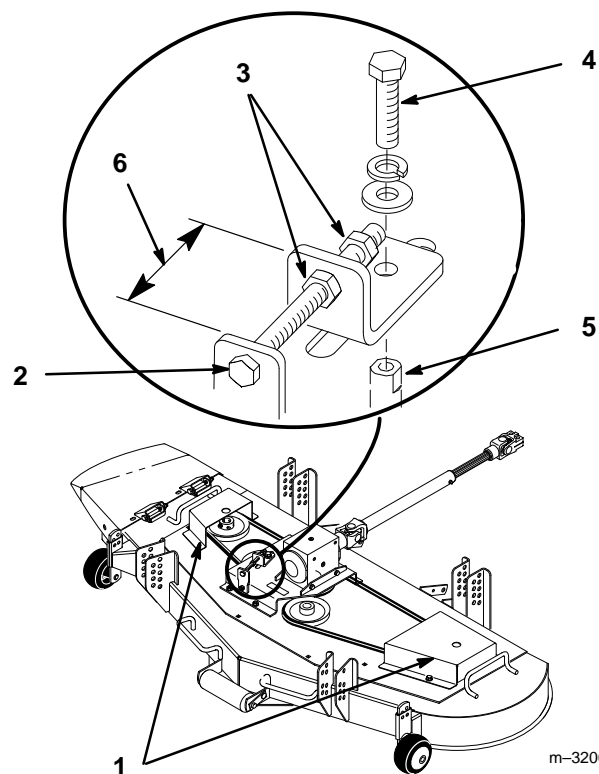

**Figure 38**

- |                 |                        |
|-----------------|------------------------|
| 1. Belt cover   | 4. Idler mounting bolt |
| 2. Tension bolt | 5. Idler hub flats     |
| 3. Jam nuts     | 6. Measure here        |

## Replacing Blade Spindle and Bearings

1. Stop the engine, remove the key and disconnect the spark plug wire(s) from the spark plug(s).
  2. Remove the deck belt: refer to Replacing the Deck Belt, page 19.
  3. Remove blade bolt, washers, blade and spindle cup (Fig. 39).
  4. Remove locknut retaining spindle pulley on spindle shaft (Fig. 39).
  5. Remove bolts securing spindle housing to mower (Fig. 39).
  6. Slide spindle assemble out bottom of mower.
  7. Press spindle and bearings out of housing (Fig. 39).
  8. Press new bearings and spindle into housing (Fig. 39).
- Note:** Sealed side of bearings must face outside to retain grease.
9. Slide pulley end of spindle assembly through hole in mower. Secure spindle assembly in place with bolts previously removed (Fig. 39).

10. Slide pulley onto spindle shaft and secure with locknut (Fig. 39).
11. Torque locknut to 100–120 ft–lb. (135–162 N•m). Rotate shaft to check for free rotation.
12. Install washer, spindle cup and blade (Fig. 39). Secure with previously removed bolt and washer.
13. Grease spindle bearings with No. 2 General purpose lithium base grease until grease is visible at lower seal.
14. Install the deck belt: refer to Replacing the Deck Belt, page 19.

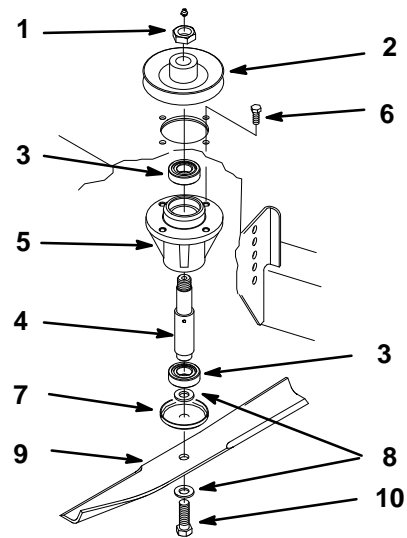

m-3181

**Figure 39**

- |                    |                  |
|--------------------|------------------|
| 1. Locknut         | 6. Housing bolts |
| 2. Pulley          | 7. Spindle cup   |
| 3. Bearing         | 8. Washer        |
| 4. Spindle Shaft   | 9. Blade         |
| 5. Spindle Housing | 10. Blade bolt   |

## Replacing the Castor Wheel Fork Bushings

The castor wheel forks are mounted in bushings pressed into the top and bottom of the carrier frame mounting tubes. To check the bushings, move the castor forks back and forth and side-to-side. If a castor fork is loose, the bushings are worn and must be replaced.

1. Raise the cutting unit so the castor wheels are off the floor, then block up the front of the mower with jack stands.
2. Remove the retaining ring and thrust washer(s) from the top of the castor wheel fork (Fig. 40).
3. Pull the castor wheel fork out of the mounting tube, leaving the thrust washers on the bottom of the fork. Remember the location of thrust washers on each fork to ensure correct installation, and to maintain a level deck.

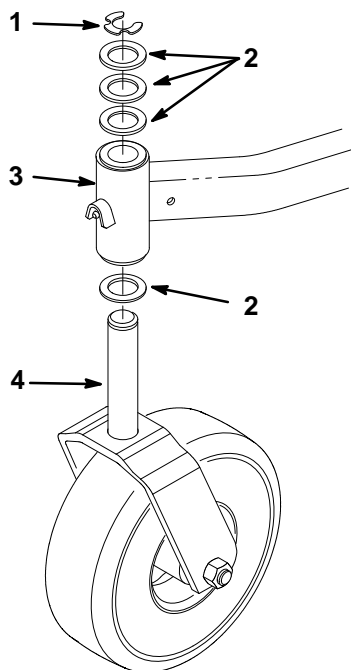

m-3191

**Figure 40**

- |                      |                                |
|----------------------|--------------------------------|
| 1. Retaining ring    | 3. Carrier Frame Mounting Tube |
| 2. Thrust Washer (4) | 4. Castor Wheel Fork           |

4. Insert a pin punch into the mounting tube and carefully drive out the bushings (Fig. 41). Clean the inside of the mounting tube.
  5. Grease the inside and outside of the new bushings. Use a hammer and flat plate to carefully drive the bushings into the mounting tube (Fig. 41).
  6. Inspect the castor wheel fork for wear and replace if necessary (Fig. 40).
  7. Slide the castor wheel fork through the bushings in the mounting tube. Replace the thrust washer(s) onto the fork and secure with the lynch pin (Fig 40).
- IMPORTANT: The inside diameter of the bushings may collapse slightly when installed. If the castor wheel fork does not slide into the new bushings, ream both bushings to an inside diameter of 1.126 in. (28.6mm).**
8. Grease the fitting on the carrier frame mounting tube using No. 2 general purpose lithium base or molybdenum base grease (Fig. 41).

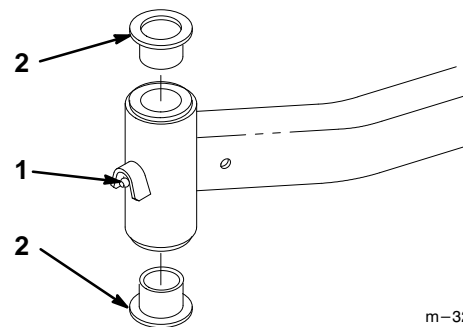

m-3282

**Figure 41**

- |                   |            |
|-------------------|------------|
| 1. Grease fitting | 2. Bushing |
|-------------------|------------|

## Servicing the Castor Wheels and Bearings

The castor wheels rotate on a roller bearing supported by a spanner bushing. If the bearing is kept well lubricated, wear will be minimal. Failure to keep the bearing well lubricated will cause rapid wear. A wobbly castor wheel usually indicates a worn bearing.

1. Remove the locknut and wheel bolt holding the castor wheel to the castor fork (Fig. 42).
2. Remove the washer and bushing, then pull the spanner bushing and roller bearing out of the wheel hub (Fig. 42).
3. Remove the other bushing from the wheel hub and clean any grease and dirt from the wheel hub (Fig. 42).
4. Inspect the roller bearing, bushings, spanner bushing and inside of the wheel hub for wear. Replace any defective or worn parts (Fig. 42).

5. To assemble, place one (1) bushing into the wheel hub. Grease the roller bearing and spanner bushing and slide them into the wheel hub. Place the second bushing into the wheel hub (Fig. 42).
6. Install the castor wheel into the castor fork and secure with the wheel bolt and locknut. Tighten the locknut until the spanner bushing bottoms against the inside of the castor forks (Fig. 42).
7. Grease the fitting on the castor wheel using No. 2 general purpose lithium base or molybdenum base grease.

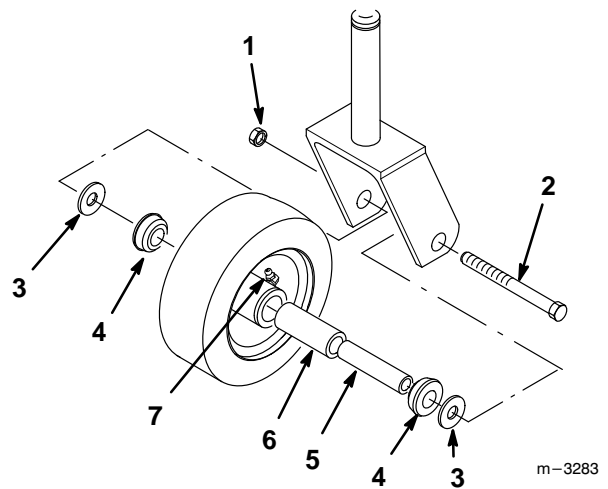

Figure 42

- |               |                    |
|---------------|--------------------|
| 1. Locknut    | 5. Spanner Bushing |
| 2. Wheel Bolt | 6. Roller Bearing  |
| 3. Washer     | 7. Grease fitting  |
| 4. Bushing    |                    |

## Replacing Push Arm Bushings

The push arms have pressed in bushings on the end mounted to the traction unit. To check the bushings, move the push arms side-to-side and examine for wear. If a push arm is loose, the bushings are worn and must be replaced.

1. Remove the mower: refer to Removing the Mower in the Installation section.
2. Inspect the pivot pin assembly for wear and replace if necessary.
3. Remove the retaining ring and flat washer securing the push arm to the mower (Fig. 43).

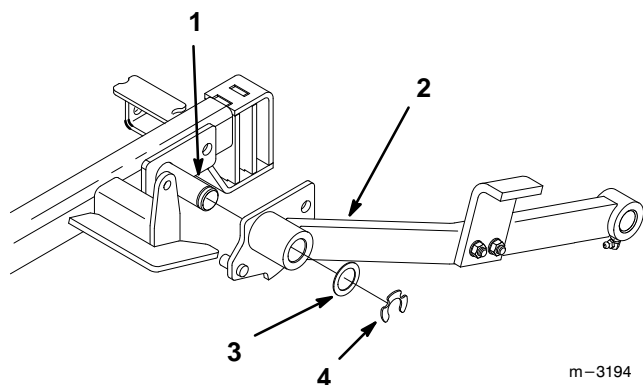

**Figure 43**

- |             |                               |
|-------------|-------------------------------|
| 1. Pin      | 3. Flat washer 1-1/2" (38 mm) |
| 2. Push arm | 4. Retaining ring             |

4. Insert a pin punch into the push arm and carefully drive out the bushings (Fig. 44). Clean the inside of the push arm.
5. Use a hammer and flat plate to carefully drive new bushings into the end of push arm (Fig. 44).
6. Place push arm onto carrier frame pin and secure with 1-1/2" (38 mm) flat washer and retaining ring (Fig 43).
7. Grease the fitting on the push arm using No. 2 general purpose lithium base or molybdenum base grease.

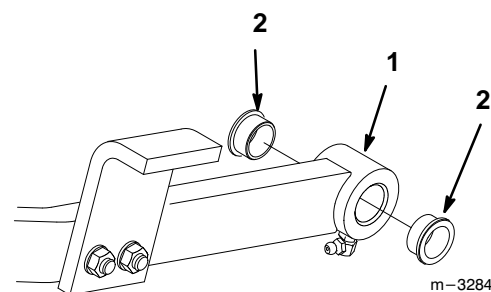

**Figure 44**

- |             |            |
|-------------|------------|
| 1. Push arm | 2. Bushing |
|-------------|------------|

## Replacing the Grass Deflector

1. Remove the locknuts, bolts and springs holding the deflector mounts to the pivot brackets (Fig. 45).
2. If the pivot brackets need to be replaced, remove the carriage bolts and cone locknuts holding the old brackets to the top of the discharge opening, then install the replacement pivot brackets. Make sure the carriage bolt heads are on the inside of the cutting unit (Fig. 45).
3. Install the deflector mounts onto the pivot brackets with the bolts, springs and locknuts. Make sure the straight ends of the springs are positioned between the deflector mounts and the grass deflector (Fig. 45).
4. Tighten the locknuts until they contact the pivot brackets (Fig. 45).

**IMPORTANT: The grass deflector must be spring-loaded in the down position. Lift the deflector up to test that it snaps to the full down position.**

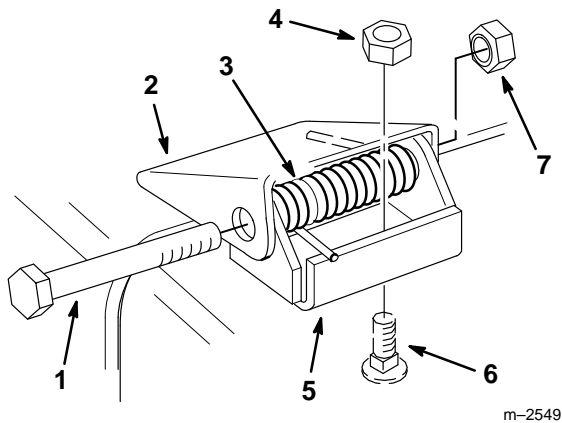

Figure 45

- |                    |                  |
|--------------------|------------------|
| 1. Bolt            | 5. Pivot Bracket |
| 2. Deflector Mount | 6. Carriage Bolt |
| 3. Spring          | 7. Locknut       |
| 4. Cone Locknut    |                  |

## Storage

1. Clean any dirt and chaff from the top of the mower.
2. Scrape any heavy buildup of grass and dirt from the underside of the mower, then wash the mower with a garden hose.
3. Check the condition of the blades. Refer to Cutting Blades on page 13.
4. Check the condition of the deck belt.
5. Check and tighten all bolts, nuts and screws. Repair or replace any part that is damaged or defective.
6. Paint all scratched or bare metal surfaces. Paint is available from your Authorized Service Dealer.
7. Store the machine in a clean, dry garage or storage area. Cover the machine to protect it and keep it clean.

# Troubleshooting

PROBLEM	POSSIBLE CAUSES	CORRECTIVE ACTION
Abnormal vibration.	<ol style="list-style-type: none"> <li>1. Cutting blade(s) is/are bent or unbalanced.</li> <li>2. Blade mounting bolt is loose.</li> <li>3. Drive shaft bolts are loose.</li> <li>4. Loose gearbox pulley, idler pulley, or blade pulley.</li> <li>5. Gearbox pulley is damaged.</li> <li>6. Blade spindle bent.</li> </ol>	<ol style="list-style-type: none"> <li>1. Install new cutting blade(s).</li> <li>2. Tighten blade mounting bolt.</li> <li>3. Tighten drive shaft bolts.</li> <li>4. Tighten the appropriate pulley.</li> <li>5. Replace gearbox pulley.</li> <li>6. Replace spindle.</li> </ol>
Uneven cutting height.	<ol style="list-style-type: none"> <li>1. Blade(s) not sharp.</li> <li>2. Cutting blade(s) is/are bent.</li> <li>3. Mower is not level.</li> <li>4. Underside of mower is dirty.</li> <li>5. Tire pressure is incorrect.</li> <li>6. Blade spindle bent.</li> </ol>	<ol style="list-style-type: none"> <li>1. Sharpen blade(s).</li> <li>2. Install new cutting blade(s).</li> <li>3. Level mower from side-to-side and front-to-rear.</li> <li>4. Clean the underside of the mower.</li> <li>5. Adjust tire pressure.</li> <li>6. Replace spindle.</li> </ol>
Blades do not rotate.	<ol style="list-style-type: none"> <li>1. PTO drive belt is broken</li> <li>2. Deck belt is off pulley.</li> <li>3. Deck belt is broken</li> </ol>	<ol style="list-style-type: none"> <li>1. Install new drive belt.</li> <li>2. Install deck pulley and check the idler pulley, idler arm and spring for correct position and function.</li> <li>3. Install new deck belt.</li> </ol>

