



**Count on it.**

**Parts Catalog**

**55cm Recycler<sup>®</sup>**

**Lawn Mower with SmartStow<sup>®</sup>**

Model No. 20965—Serial No. 40000000 and Up



# Ordering Replacement Parts

To order replacement parts, please supply the part number, the quantity, and the description of each part desired.

## **Understanding Reference Numbers**

Each identified part in an illustration has a reference number. The reference number for a part also appears in the parts list, along with other information about the part.

This catalog uses two special reference number formats, one to indicate parts in a service assembly and another to indicate the quantity of a given part in an illustration.

## **Service Assembly Reference Numbers**

Parts in service assemblies have reference numbers in the form a:b. The a represents the reference number of the entire service assembly and the b represents a sequential number unique to each part within the service assembly.

For example, a wheel assembly might be identified by reference number 6, the tire by 6:1, the valve by 6:2, and the wheel by 6:3. When you order the assembly identified by reference number 6, you receive all parts identified by reference numbers 6:1, 6:2, and 6:3. However, you may also order any part individually. Reference numbers of this type appear in illustration and in parts lists.

## **Reference Numbers Indicating Quantity**

In an illustration, if a reference number indicates more than one part, the reference number has the form nX y. The n represents the quantity of the part, the X is the multiplication symbol, and the y represents the reference number.

For example, in an illustration, the reference number 2X 37 means that two of the parts identified by reference number 37 are indicated.

# Contents

Housing and Baffle Assembly .....	4
Bag Assembly .....	6
Engine and Blade Assembly .....	8
Front Wheel and Height-of-Cut Assembly .....	10
Rear Wheel and Height-of-Cut Assembly .....	12
Handle Assembly .....	14
Attachments and Accessories .....	16

# Housing and Baffle Assembly

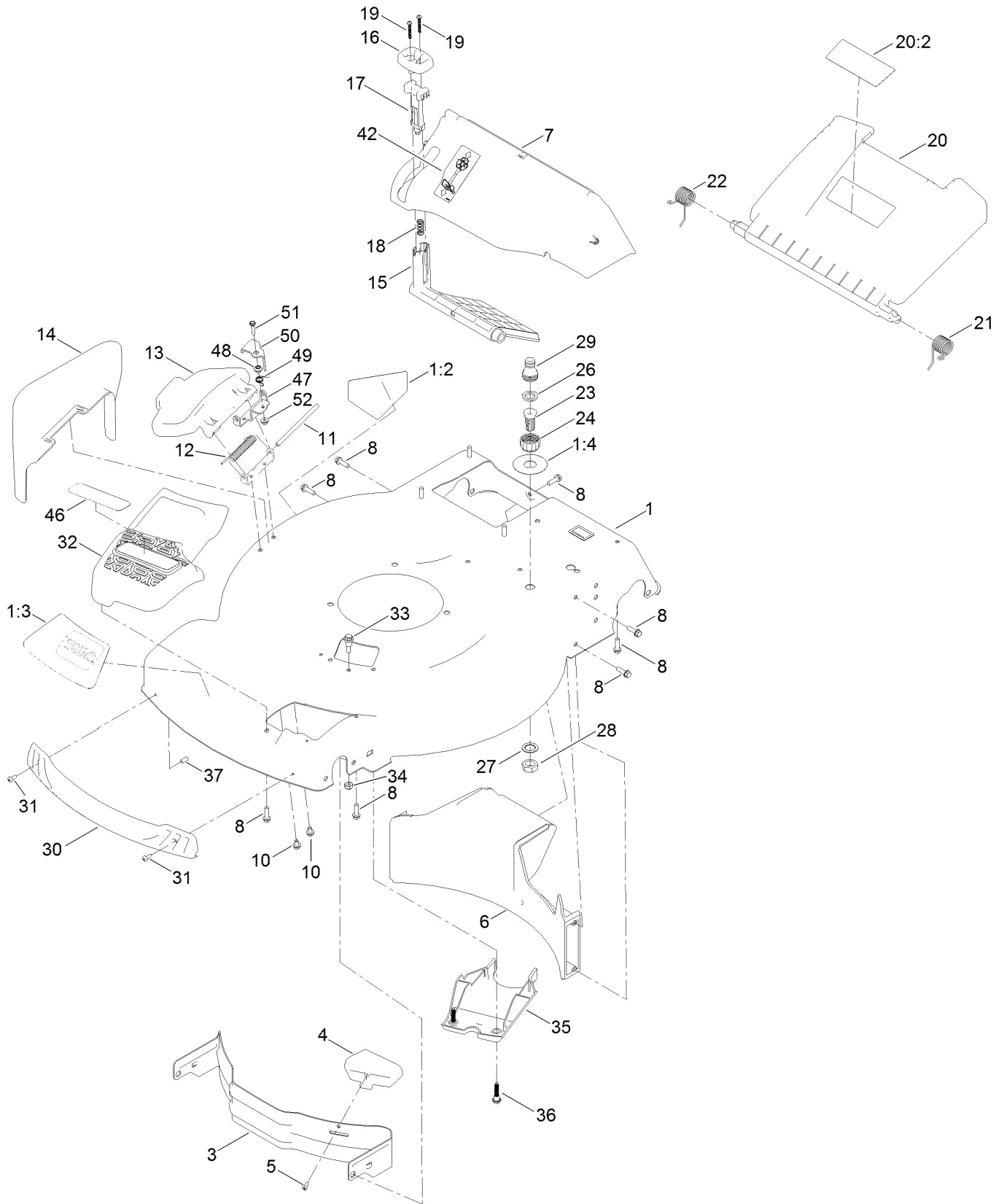

## Housing and Baffle Assembly (continued)

<i>Ref.</i>	<i>Part Number</i>	<i>Qty.</i>	<i>Description</i>	<i>Ref.</i>	<i>Part Number</i>	<i>Qty.</i>	<i>Description</i>
1	131-9671	1	Housing ASM	23	112-6400	1	Port-Washout
1:2	112-8760	1	Decal-Danger	24	112-6401	1	Coupling-Hose, Washout Port
1:3	120-3323	1	Decal-Deck	26	112-6438	1	Washer-Seal, Washout Port
1:4	137-9196	1	Decal-Quick Wash	27	3254-5	1	Washer-Tooth, Internal
3	115-4667-01	1	Baffle-Front	28	3218-6	1	Nut-Jam
4	115-4672	1	Kicker-Front	29	112-6437	1	Adapter-Connect, Quick
5	32144-111	1	Screw-PPH	30	114-7987	1	Bumper
6	114-7961	1	Baffle-Rear	31	105-6849	2	Screw-Forming, Thread
7	136-5882	1	Chute-Recycle	32	137-4821	1	Cover-Belt, Front
8	46-8091	11	Screw-HWH	33	104-0858	1	Bolt-Shoulder
10	99-8445	2	Screw-HWH	34	3296-16	1	Nut-Lock, NI
11	99-5291	1	Rod-Cover	35	133-1973	1	Cover-Belt, Front
12	99-5293	1	Spring-Torsion	36	131-0837	2	Screw-Shoulder, HHF
13	115-8449	1	Deflector-Side	37	130-6660	2	Cap-Plug
14	115-8447	1	Chute-Discharge, Side	42	125-5026	1	Decal
15	114-7960	1	Deflector-Recycle	46	137-4818	1	Decal-Belt Cover, Powereverse
16	114-7958	1	Knob-Recycle	47	138-3209	1	Bracket-Lockout
17	114-7959	1	Latch-Recycle	48	107-7463	1	Spacer
18	117-1031	1	Spring-Compression	49	107-7462	1	Spring-Torsion
19	32104-120	2	Screw-PPH	50	137-9197	1	Lever-Lockout
20	137-9139	1	Rear Door ASM	51	106-9169	1	Screw-HWH
20:2	131-4514	1	Decal-Warning	52	32128-17	1	Nut-Lock, Flange
21	115-2859	1	Spring-Torsion				
22	114-7924	1	Spring-Torsion				

# Bag Assembly

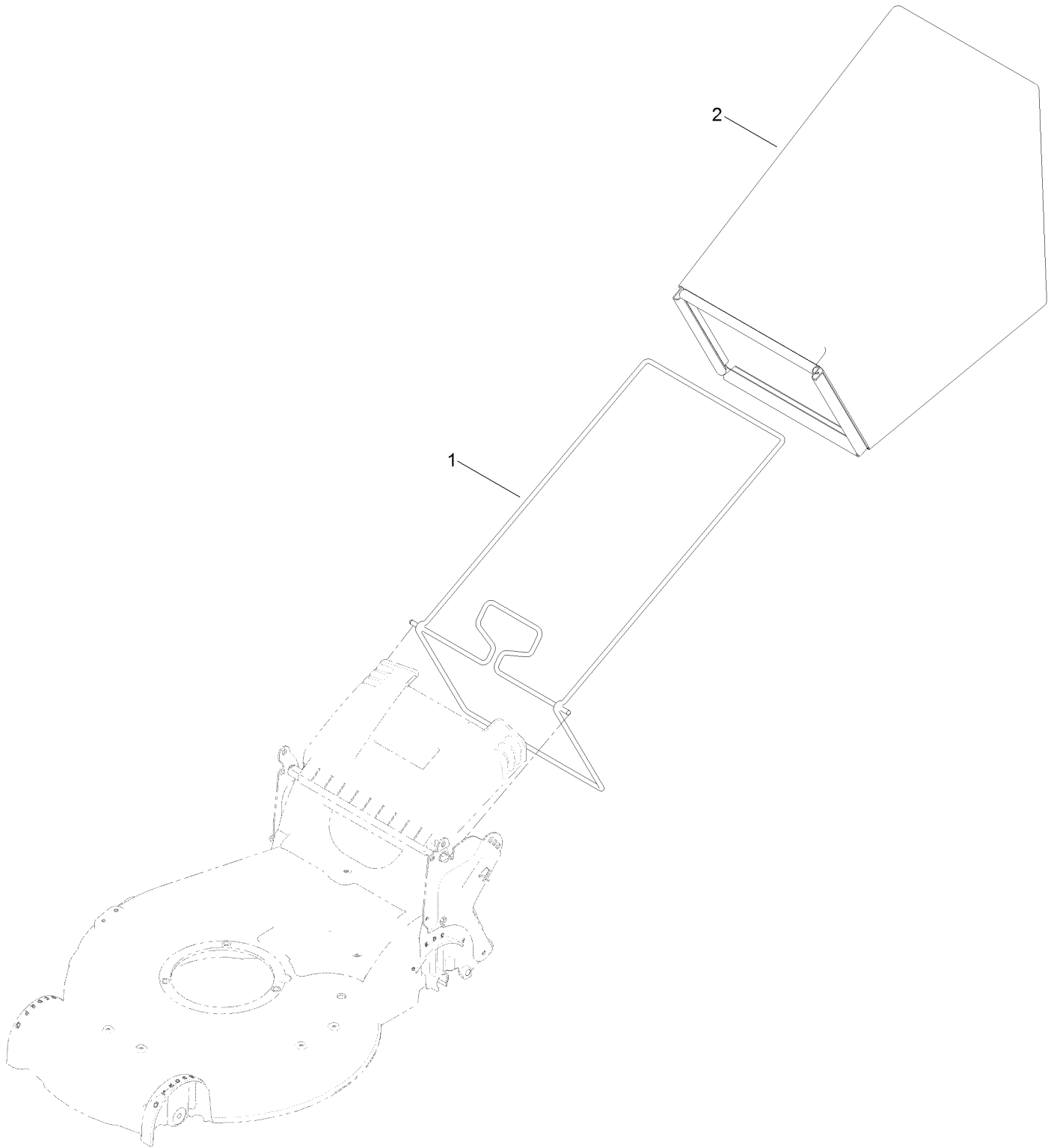

## Bag Assembly (continued)

<i>Ref.</i>	<i>Part Number</i>	<i>Qty.</i>	<i>Description</i>
1	132-4529-03	1	Bag Frame ASM
2	114-2664	1	Grass Bag ASM

# Engine and Blade Assembly

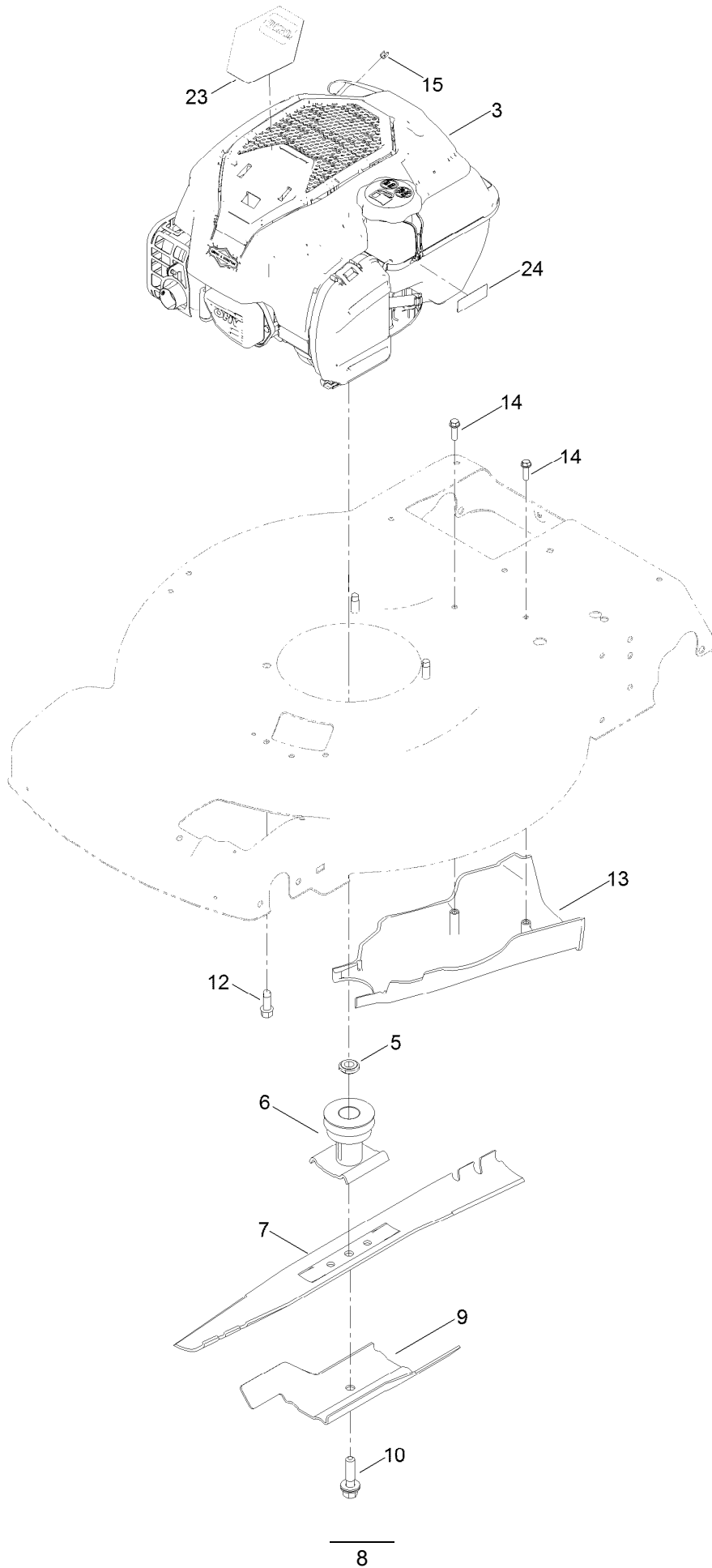



## Engine and Blade Assembly (continued)

<i>Ref.</i>	<i>Part Number</i>	<i>Qty.</i>	<i>Description</i>	<i>Ref.</i>	<i>Part Number</i>	<i>Qty.</i>	<i>Description</i>
3		1	Engine-Briggs,104M020130F1 ●■	12	95-1726	3	Screw-Taptite
5	106-3999	1	Spacer-Driver	13	130-6709	1	Cover-Belt, Rear
6	130-6705	1	Driver-Blade	14	46-8091	2	Screw-HWH
7	131-9683-03	1	Blade	15	2210-316	1	Stop-Rope
9	105-6848-03	1	Accelerator-Blade	23	133-8176	1	Decal-Shroud
10	125-2466	1	Bolt-Blade	24	133-8198	1	Decal-Level, Fuel

● Not serviced separately

■ Obtain parts from [www.briggsandstratton.com](http://www.briggsandstratton.com)

# Front Wheel and Height-of-Cut Assembly

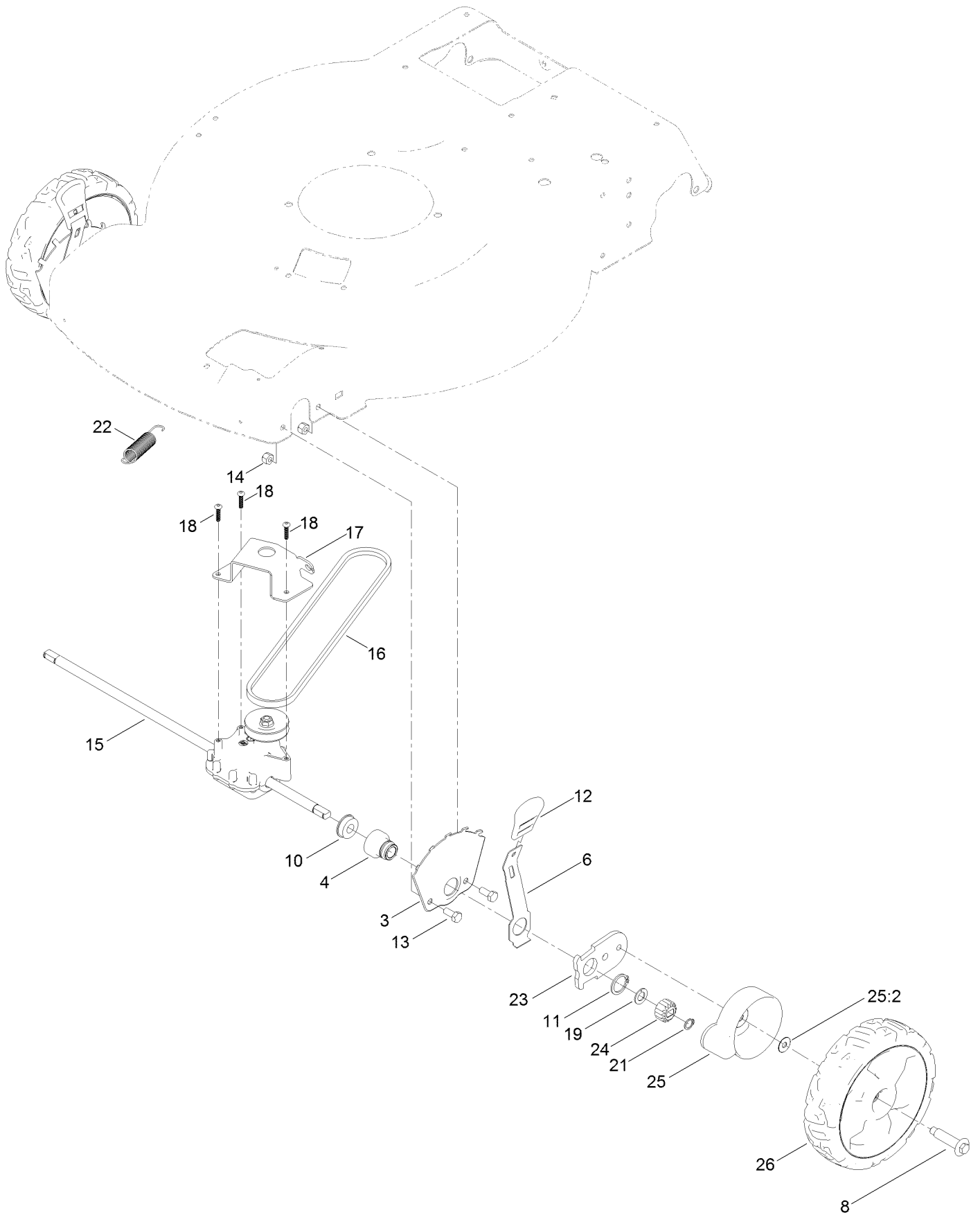

## Front Wheel and Height-of-Cut Assembly (continued)

<i>Ref.</i>	<i>Part Number</i>	<i>Qty.</i>	<i>Description</i>	<i>Ref.</i>	<i>Part Number</i>	<i>Qty.</i>	<i>Description</i>
3	115-1956-03	2	Plate-HOC, Front	17	114-7978-03	1	Bracket-Transmission
4	131-0836	2	Retainer-Bearing, HOC	18	108-7476	3	Screw-Plastite
6	105-1809	2	Arm-Spring	19	110-7191	2	Washer-Thrust
8	614650	2	Bolt-Shoulder	21	32151-61	2	Ring-Retaining
10	104-8699	2	Bearing-Ball	22	136-7059	1	Spring-Extension
11	32151-36	2	Ring-Retaining	23	137-9184	2	Arm-Pivot, Front
12	110-0549	2	Knob-HOC	24	131-5399	2	Gear-Pinion, 15T
13	322-3	4	Screw-HH	25	136-9057	2	Gear Cover ASM
14	3296-29	4	Nut-Lock, NI	25:2	614426	1	Washer-Stepped
15	137-4823	1	Transmission	26	130-6714	2	Wheel Gear ASM, 8In
16	71-9450	1	V-Belt				

# Rear Wheel and Height-of-Cut Assembly

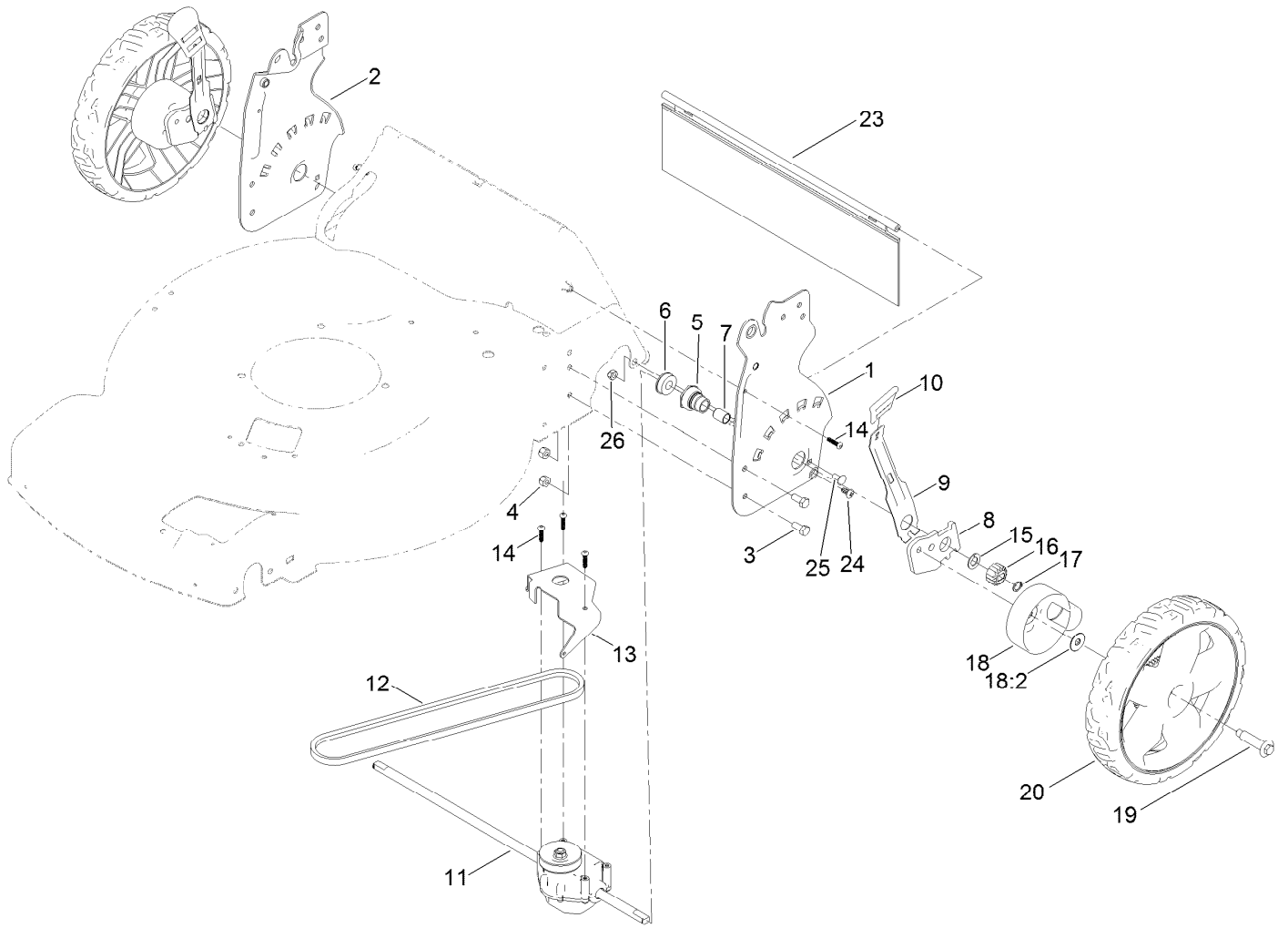

## Rear Wheel and Height-of-Cut Assembly (continued)

<i>Ref.</i>	<i>Part Number</i>	<i>Qty.</i>	<i>Description</i>	<i>Ref.</i>	<i>Part Number</i>	<i>Qty.</i>	<i>Description</i>
1	137-9104	1	ASM-Plate, HOC (LH)	14	108-7476	5	Screw-Plastite
2	137-9103	1	ASM-Plate, HOC (RH)	15	110-7191	2	Washer-Thrust
3	322-3	4	Screw-HH	16	131-5399	2	Gear-Pinion, 15T
4	3296-29	4	Nut-Lock, NI	17	32151-61	2	Ring-Retaining
5	108-9779	2	Retainer-Bushing, HOC	18	136-9057	2	Gear Cover ASM
6	104-8699	2	Bearing-Ball	18:2	614426	1	Washer-Stepped
7	108-9782	2	Bushing-Sleeve	19	614650	2	Bolt-Shoulder
8	136-9090	2	Arm-Pivot, Rear	20	136-5859	2	Wheel Gear ASM
9	132-4486	2	Arm-Spring	23	120-7012	1	Shield-Trailing
10	110-0549	2	Knob-HOC	24	117-1092	2	Screw-PTH
11	131-9696	1	Transmission	25	3229-11	2	Screw-CARR
12	91-2258	1	Belt-V	26	3296-16	2	Nut-Lock, NI
13	132-4481-01	1	Bracket-Transmission				

# Handle Assembly

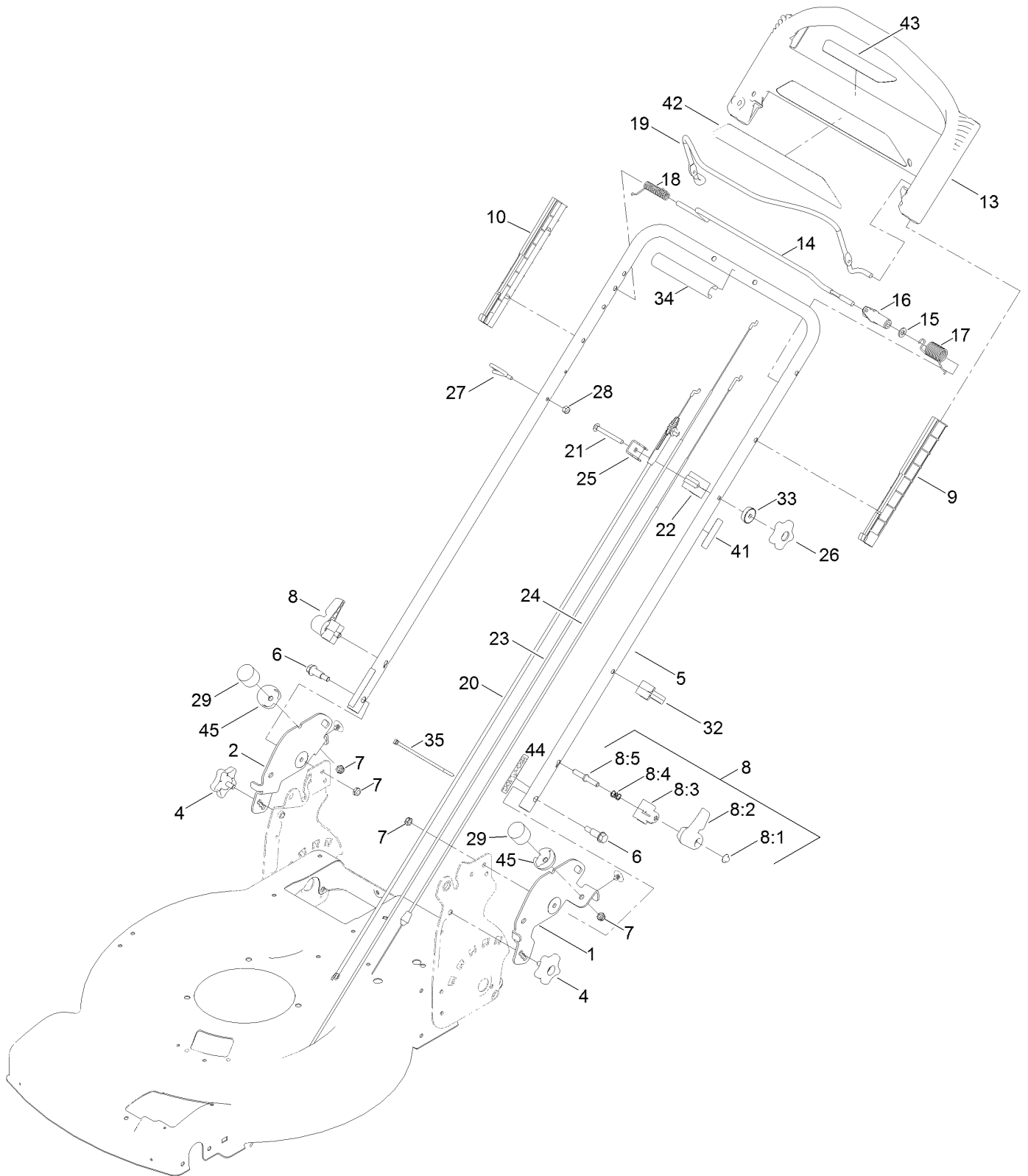

## Handle Assembly (continued)

<i>Ref.</i>	<i>Part Number</i>	<i>Qty.</i>	<i>Description</i>	<i>Ref.</i>	<i>Part Number</i>	<i>Qty.</i>	<i>Description</i>
1	137-4839-03	1	Bracket-Float, LH	19	131-0880-03	1	Bail-Brake
2	137-4838-03	1	Bracket-Float, RH	20	115-8437	1	Cable-Brake
4	137-4844	2	Knob-Handle	21	3229-8	1	Screw-CARR
5	137-4793-05	1	Handle-Upper	22	130-6716	1	Mount-Cable, Traction
6	130-2344	2	Bolt-Shoulder	23	137-4814	1	Cable-Traction, Front
7	3296-47	4	Nut-Lock, NI	24	137-4815	1	Cable-Traction, Rear
8	115-2860	2	Quick Release ASM	25	136-5922	1	Clamp-Cable
8:1	109-0917	1	Nut-Push	26	131-0897	1	Knob-Handle, Locking
8:2	114-7995	1	Lever	27	86-9671	1	Guide-Rope
8:3	114-7996	1	Anchor-Spring	28	3296-73	1	Nut-Lock, NI
8:4	115-2858	1	Spring-Compression	29	137-4803	2	Bumper-Rubber
8:5	114-2675	1	Rod-Release	32	114-7988	1	Guide-Cable
9	136-5879	1	Guide-LH	33	136-9075	1	Washer-Curved
10	136-5880	1	Guide-RH	34	131-4551	1	Handle-Cover
13	136-5877	1	Handle-Pace, Personal	35	614249	1	Tie-Cable
14	136-7150	1	Bar-Control, Traction	41	136-9096	1	Decal-Adjustment
15	3256-23	1	Washer-Plain	42	136-9138	1	Decal-Powereverse
16	136-5878	1	Lever-Traction	43	138-3278	1	Decal-Instruction, Drive
17	136-5883	1	Spring-Torsion	44	137-4801	2	Decal-Isoflex
18	121-9118	1	Spring-Torsion	45	137-9100	2	Cover-Bumper

# Attachments and Accessories

## For 20965 55cm Recycler Lawn Mower with SmartStow

<b>Product Name</b>	<b>Model/Part</b>
Fuel Stabilizer .05 oz .....	130-2393
AWD Replacement Bag and Frame Kit .....	131-4556
Traction Assist Handle Kit.....	131-4590
Lawn Striping Kit with 22in Roller.....	20601
22 Inch Atomic Blade.....	59534P



**Notes:**

**Notes:**

**Notes:**



**Count on it.**