



ProLine

**14 HP / 48" MSM Kawasaki**

Model No. 30196 – 890001 & Up

---

**Parts Catalog**

## ORDERING REPLACEMENT PARTS

To order replacement parts, please supply: the part number, the quantity, and the description of each part desired.

## Contents

Description	Page	Description	Page
Engine & Fuel Tank .....	1	Brake Assembly .....	8
Transmission, Pulleys And Drive Belt .....	2-3	Spindles And Blades .....	9
Wheel, Brakes And Traction Belts .....	4	Center Spindles And Blade .....	10
Handle Asm .....	5	Toro Part Number Index .....	11-15
Deck, Cover and Deck Drive Belts .....	6	Maintenance Record .....	16
Deck, Drive Pulleys And Deflector .....	7	<b>Note:</b>	

## Accessories

Description	Model / Parts No.	Description	Model / Parts No.
Recycler Kit .....	Model No. 30143		
Bagging Kit .....	Model No. 30198		
Low Sail Blade .....	Part No. E403149		

## Part Description Abbreviations

Part descriptions in this catalog may include the following abbreviations.

Abbreviation	Meaning	Abbreviation	Meaning
AR .....	as required	HWHTF .....	hex washer head thread forming
ASM .....	assembly	INC .....	incorporated
CARR .....	carriage	LH .....	left hand
DEG .....	degrees	PH .....	pan head
FH .....	flat head	PPH .....	Phillips pan head
GA .....	gauge	PTO .....	power take off
HF .....	hex flange	RH .....	right hand
HFV .....	hex flange washer	SFH .....	slotted fillister head
HH .....	hex head	SH .....	square head
HHF .....	hex head flange	SHWH .....	slotted hex washer head
HHST .....	hex head self tapping	SPH .....	slotted pan head
HJ .....	hex jam	STD .....	standard
HOC .....	height-of-cut	TAP .....	self tapping
HS .....	hex socket	TH .....	truss head
HSBH .....	hex socket button head	TTH .....	Torx truss head
HSFH .....	hex socket flat head	WH .....	wing head
HSH .....	hex socket head		
HWH .....	hex washer head		

## Important Format Explanations

This catalog uses special formats to convey information in illustrations and parts lists. Specifically, one format is used in conjunction with service assemblies and another with quantities associated with reference numbers.

## Service Assemblies

Parts within service assemblies have reference numbers in the form  $X:Y$ .  $X$  is the reference number of the service assembly and  $Y$  is a sequential number unique to each part within the service assembly.

For example, a wheel assembly might be identified by reference number 6, the tire by 6:1, the valve by 6:2, and the wheel by 6:3. When you order the assembly identified by reference number 6, you receive all parts identified by reference numbers 6:1, 6:2, and 6:3. However, you may also order any part individually.

Reference numbers of this type appear in part lists and as callouts in illustrations.

## Reference Numbers with Quantities

Illustrations may have a quantity in parentheses next to a reference number, in the form  $X (Y)$ .  $X$  is the reference number.  $Y$  in parentheses is the quantity of the part identified by the reference number.

For example, the illustration callout 4 (2) indicates that two parts are used in that instance.

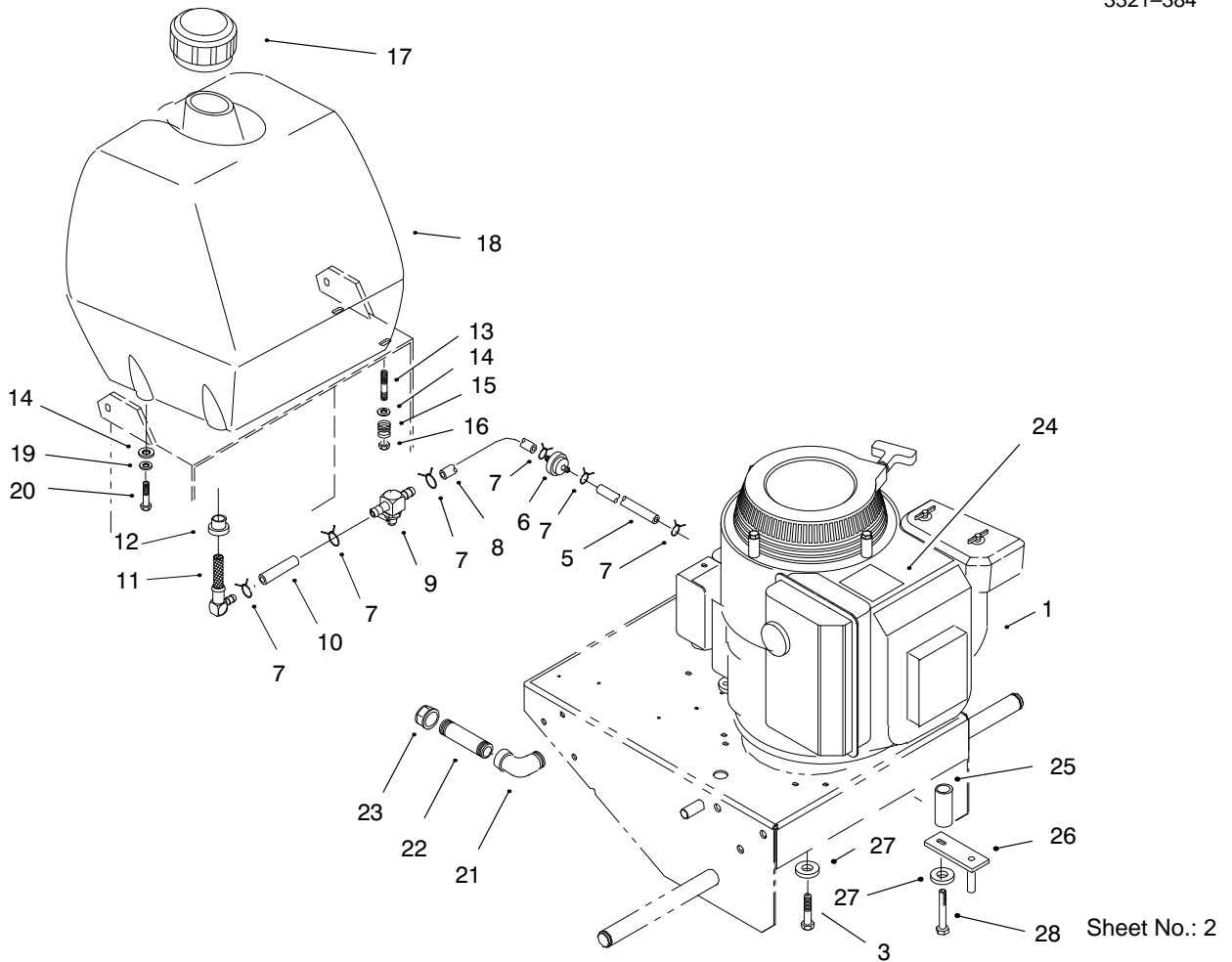

## Engine & Fuel Tank

Ref. No.	Part No.	Qty.	Description
1		1	Engine-Kawasaki Model Fc420v-Es-15 Obtain Parts From Kawasaki
3	33114-025	1	Screw-HH
4	E303308	1	Clamp
5	E303471	1	Fuel Line-12 Inch
6	E303197	1	Filter
7	E303077	5	Clamp
8	E603776	1	Fuel-Line
9	E603770	1	Valve-Gas
10	E603955	1	Fuel-Line
11	E543277	1	Elbow
12	E513645	1	Bushing
13	E633023	2	Stud
14	3256-2	4	Washer-Flat
15	E633349	2	Spring-Fuel Tank
16	3296-29	2	Nut-Lock
17	E513508	1	Cap-Fuel Tank
18	E323551	1	Tank
19	3253-4	2	Washer-Lock
20	322-3	2	Screw-HH
21	E303431	1	Elbow
22	E323326	1	Nipple
23	E543233	1	Cap
24	63-8440	1	Decal-Hot Surface

Ref. No.	Part No.	Qty.	Description
25	E323228	3	Spacer
26	E322110	3	Guide-Belt
27	E303334	4	Washer-Lock
28	E809065	3	Screw-HH

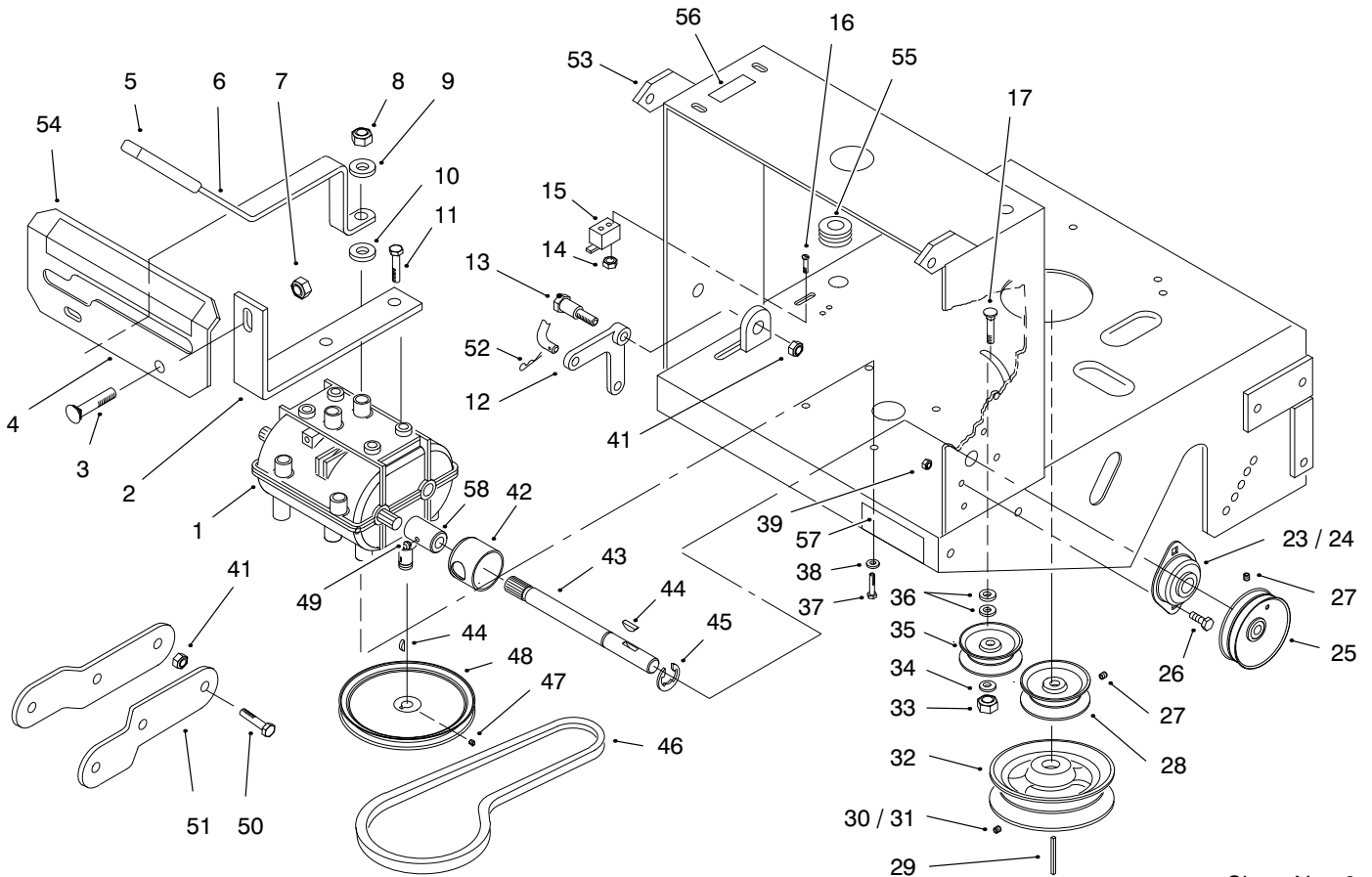

Sheet No.: 3

## Transmission, Pulleys And Drive Belt

Ref. No.	Part No.	Qty.	Description
1		1	Transmission—Peerless Model No. 700-070a Obtain Parts From Peerless
2	E323389	2	Leg-Shift Lever
3	3230-1	21	Bolt-CARR
4	E323387	1	Shifter Plate
5	E303020	1	Grip
6	E323570	1	Lever-Shift
7	32128-20	2	Nut-Lock
8	3296-6	1	Nut-Lock
9	E303327	1	Washer-Lock
10	E323379	1	Washer
11	32104-32	4	Screw-HH
12	E303186	1	Bell Crank
13	E603403	1	Bolt-Shoulder
14	32146-18	2	Nut-Lock
15	E513152	1	Switch-Seat
16	E803028	2	Screw
17	E807511	1	Bolt-CARR
23	E323252	2	Bearing
24	E323254	2	Flange
25	E323257	2	Sheave
26	321-3	4	Screw-HH
27	E803310	3	Screw-Set
28	E323256	1	Sheave
29	E807264	1	Key

Ref. No.	Part No.	Qty.	Description
30	3242-4	1	Screw-Set
31	3242-6	1	Screw-Sqh Set
32	E403087	1	Pulley
33	32146-2	1	Nut-Hex Lock
34	3256-24	1	Washer-Flat
35	E323285	1	Idler Pulley
36	3256-25	2	Washer-Flat
37	322-3	4	Screw-HH
38	3253-4	4	Washer-Lock
39	32146-17	4	Nut-Lock
41	32128-43	5	Nut-Flange
42	E323680	2	Coupling
43	E323502	2	Output Shaft
44	E807009	3	Key
45	E808523	2	Ring-Retaining
46	E323630	1	Belt-Trans Drive
47	E803293	2	Screw-Set
48	E323278	1	Sheave
49	302-58	2	Fitting-Grease
50	323-6	4	Screw-HH
51	E323318	2	Hitch Bracket
52	3290-307	1	Pin-Cotter
53	E322201	1	Deck-Engine
54	E323560	1	Decal-Ground Speed
55	E543296	1	Grommet-Fuel Line



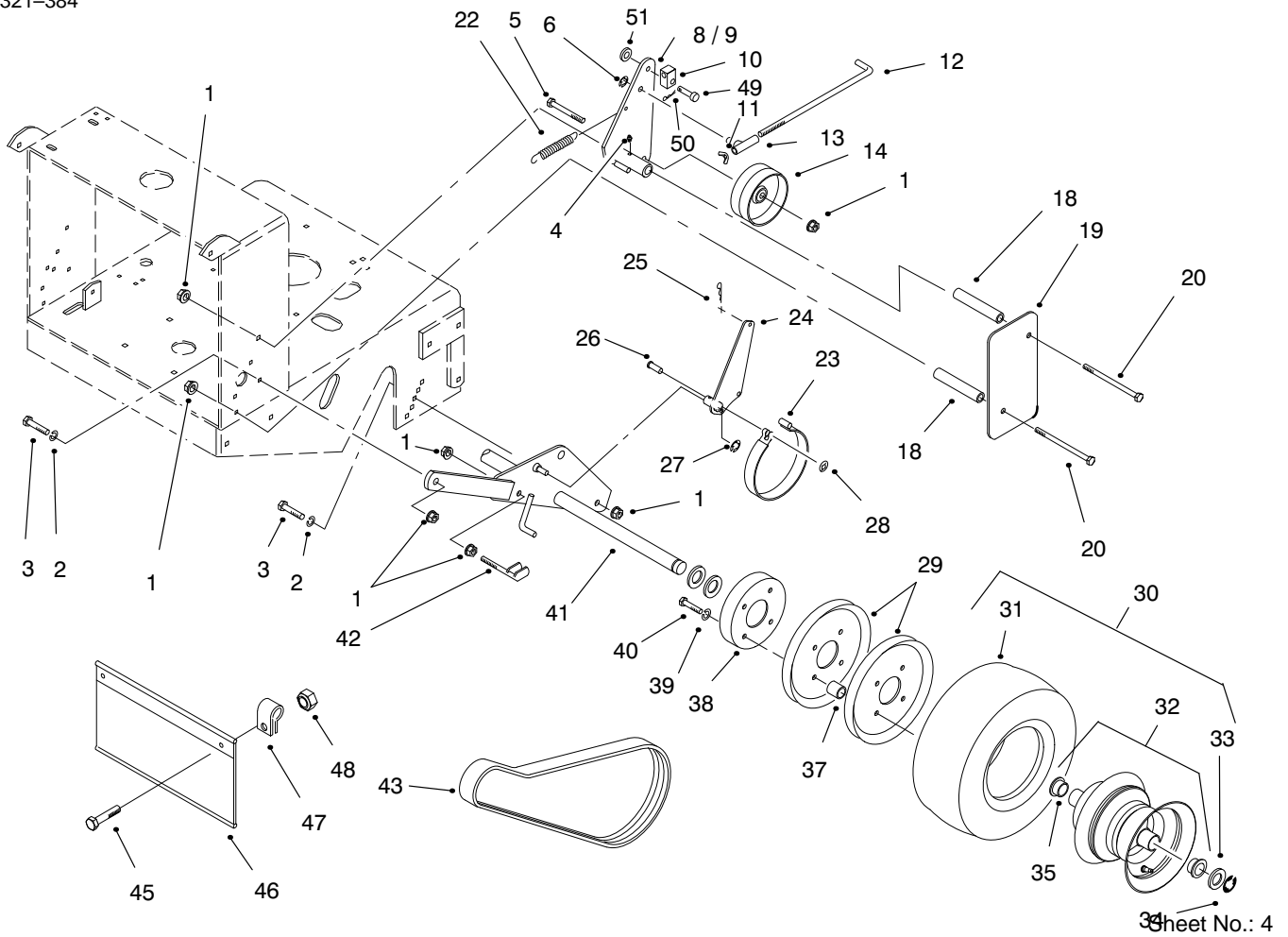

## Wheel, Brakes And Traction Belts

Ref. No.	Part No.	Qty.	Description
1	32128-43	14	Nut-Flange
2	E303327	4	Washer-Lock
3	323-6	4	Screw-HH
4	302-58	2	Fitting-Grease
5	323-11	2	Screw
6	E808522	2	Ring
8	E322205	1	Idler Arm ASM LH
9	E322206	1	Idler Arm ASM RH
10	74-0521	2	Rod-Fitting
11	E513959	2	Wingnut
12	E323296	2	Brake Rod
13	E322125	2	Swivel
14	E323634	2	Idler-Wheel Drive
18	E323694	4	Spacer
19	E323632	2	Shield
20	323-16	4	Screw-HH
22	E323574	2	Spring-Extension
23	E323595	2	Band-Brake
24	E322209	2	Brake Arm ASM
25	3290-307	2	Pin-Cotter
26	E323307	4	Pin
27	E808501	2	Ring-Retaining
28	E803051	4	Nut
29	E323253	4	Sheave
30		2	Wheel/Tire ASM
31	E303125	2	Tire

Ref. No.	Part No.	Qty.	Description
32	E323360	2	Wheel ASM w/Bearings
33	E523157	A/R	Spacer-14 GA
33	E543436	A/R	Spacer-18 GA
34	E808519	2	Ring-Retaining
35	E323329	4	Bearing
37	E323260	8	Spacer
38	E323261	2	Drum-Brake
39	3253-4	8	Washer-Lock
40	322-6	8	Screw-HH
41	E322212	1	Axle ASM
42	E412358	2	Scraper
43	E323631	2	Belt-Drive
45	3210-3	2	Screw-HH
46	E323607	1	Shield-Trailing
47	2412-104	2	Clamp
48	32146-4	2	Nut-Lock
49	283-6	2	Pin-Clevis
50	3290-307	2	Pin-Cotter
51	3256-23	2	Washer-Flat

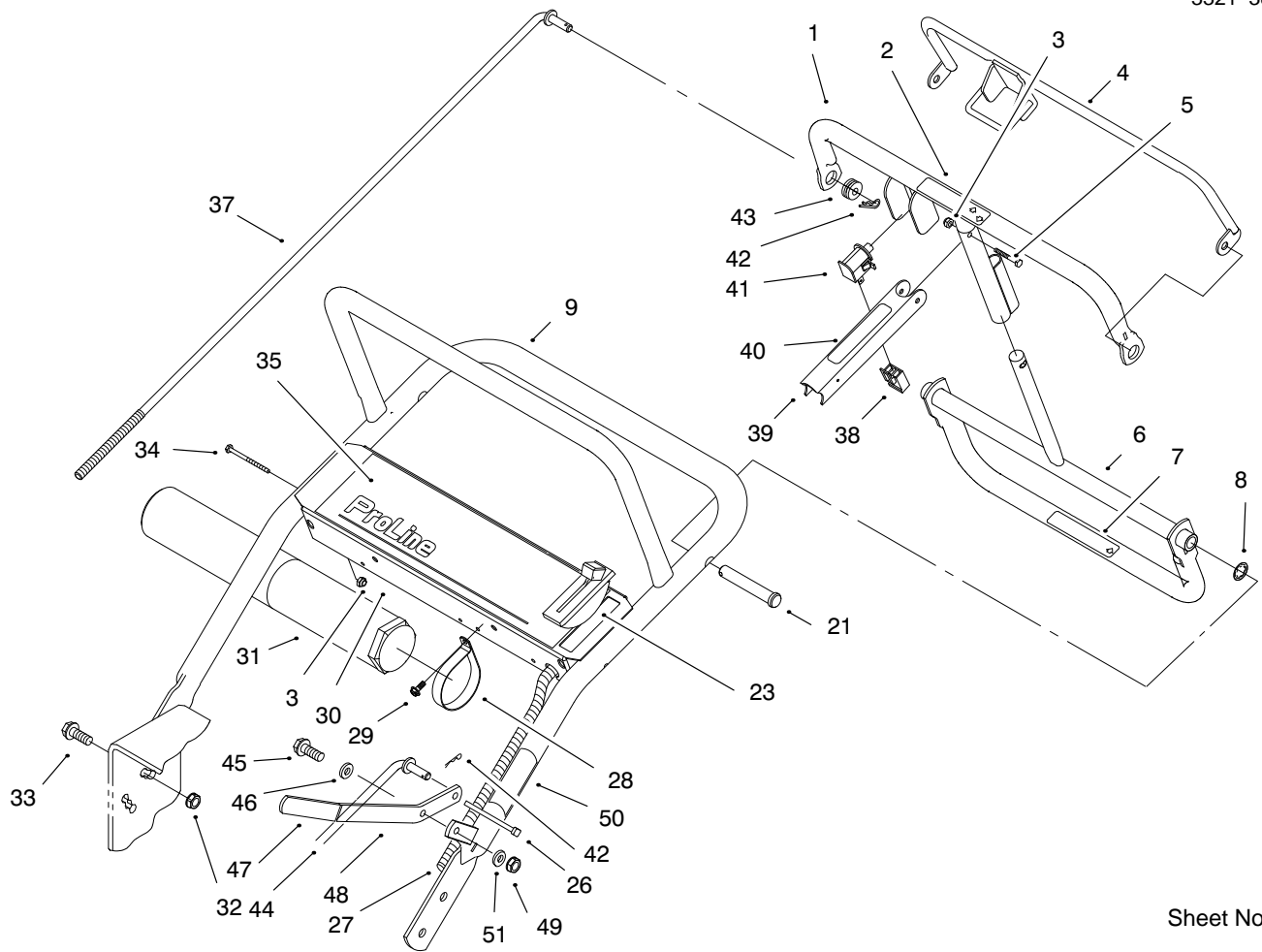

Sheet No.: 5

## Handle Asm

Ref. No.	Part No.	Qty.	Description
1	E322215	1	Control Bar
2	82-2290	1	Decal-Control Bar
3	3296-2	5	Nut-Lock
4	E322208	1	Bail ASM
5	32105-1	1	Screw-HH
6	E322207	1	Pivot-Control
7	82-2280	1	Decal-Reverse
8	32151-80	2	Ring-Push On
9	E322216	1	Upper Handle ASM
21	283-55	2	Pin-Clevis
23	E323637	1	Throttle Control
26	3290-378	2	Tie-Cable
27	E323567	1	Wire Harness-Kawasaki
28	2412-120	2	Clamp-R
29	32104-76	2	Screw-Self TAP
30	E304259	1	Control Panel ASM
31	74-0720	1	Tube-Manual
32	32128-21	4	Nut-HF
33	3234-11	4	Screw-HHF
34	32105-14	4	Screw-HH
35	E323564	1	Decal-Panel
37	E323569	2	Rod-Control
38	218-595	1	Connector-Body
39	E323614	1	Lever-Parking Brake
40	E323558	1	Decal-Parking Brake

Ref. No.	Part No.	Qty.	Description
41	740275	1	Switch-Bail
42	3290-307	3	Pin-Cotter
43	237-141	2	Grommet
44	E323576	1	Linkage-Blade Drive
45	614672	1	Bolt-Shoulder
46	47-2910	1	Washer-Thrust
47	E303020	1	Grip
48	E323573	1	Lever-Blade Engagement
49	32146-2	1	Nut-Hex Lock
50	E323563	1	Decal-Blade Engagement
51	3256-24	1	Washer-Flat

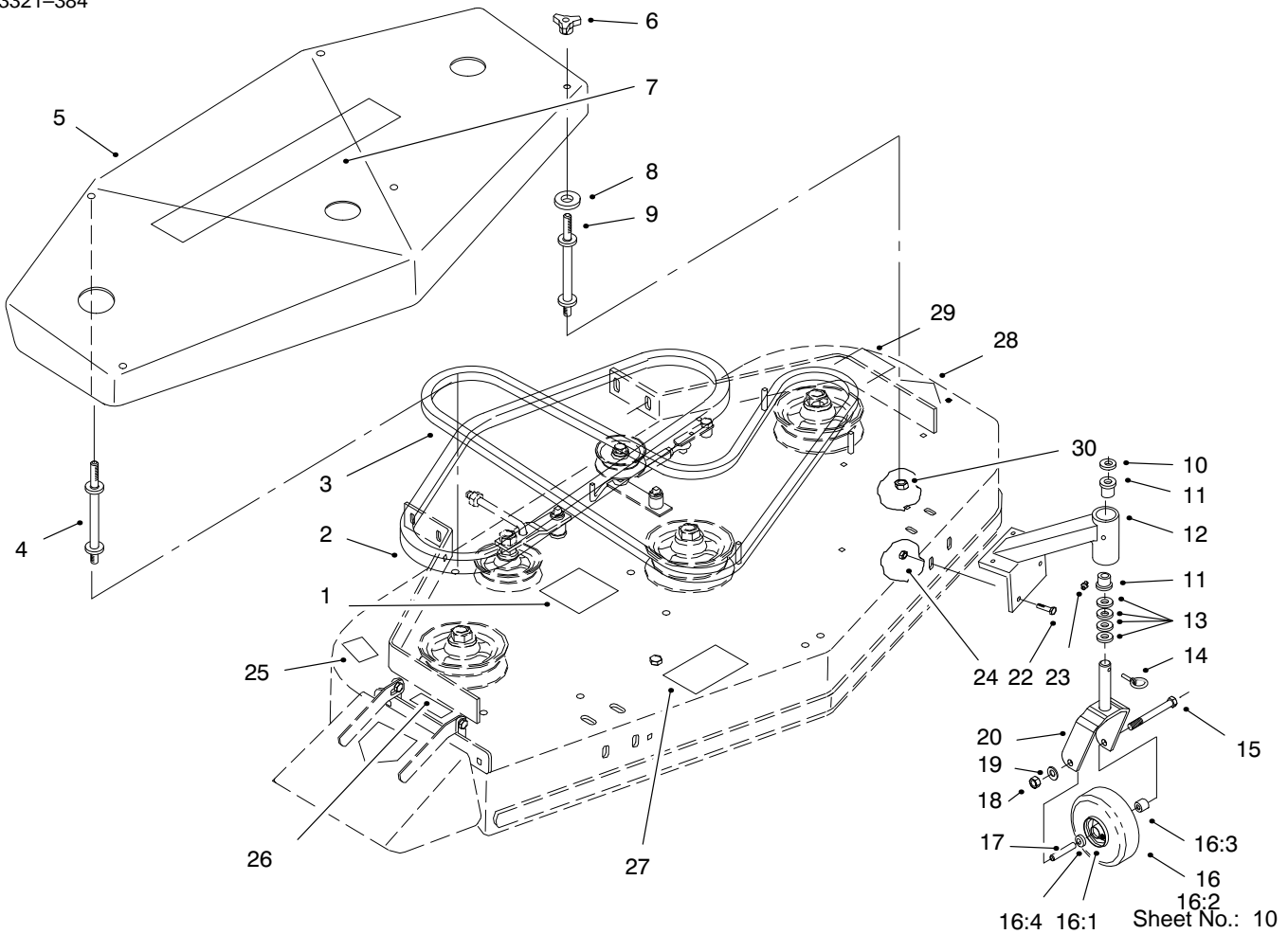

## Deck, Cover and Deck Drive Belts

Ref. No.	Part No.	Qty.	Description
1	E323594	1	Decal-Belt Routing
2	E403164	1	Belt-Blade Drive
3	E403163	1	Belt-Blade Drive
4	E303536	3	Stud-Belt Shield(Long)
5	E404246	1	Belt Cover w/Decal
6	E323385	5	Knob
7	E323561	1	Decal-Proline 48
8	E323417	5	Washer
9	E303537	2	Stud-Belt Shield(Short)
10	E513338	2	Washer
11	E303514	4	Bearing-Flanged
12	E302194	2	Support-Caster
13	E303314	8	Spacer
14	E809020	2	Pin
15	325-20	2	Screw-HH
16		2	Tire/Wheel ASM
16:1	E513807	2	Wheel Hub ASM
16:2	E513808	2	Tire
16:3	E513809	2	Bearing-Roller
16:4	E513810	4	Bushing
17	E513547	2	Spacer
18	3217-9	2	Nut-HH
19	3253-7	2	Washer-Lock
20	E322145	2	Fork

Ref. No.	Part No.	Qty.	Description
22	323-4	8	Screw-HH
23	E811001	2	Zerk
24	32128-43	8	Nut-Flange
25	98-3269	1	Decal-Made In USA
26	67-5360	1	Decal-Danger
27	66-1340	1	Decal-Discharge
28	43-8480	1	Decal-Danger
29	E323659	1	Decal-Torque
30	32128-20	5	Nut-Lock

16:4 16:1 Sheet No.: 10

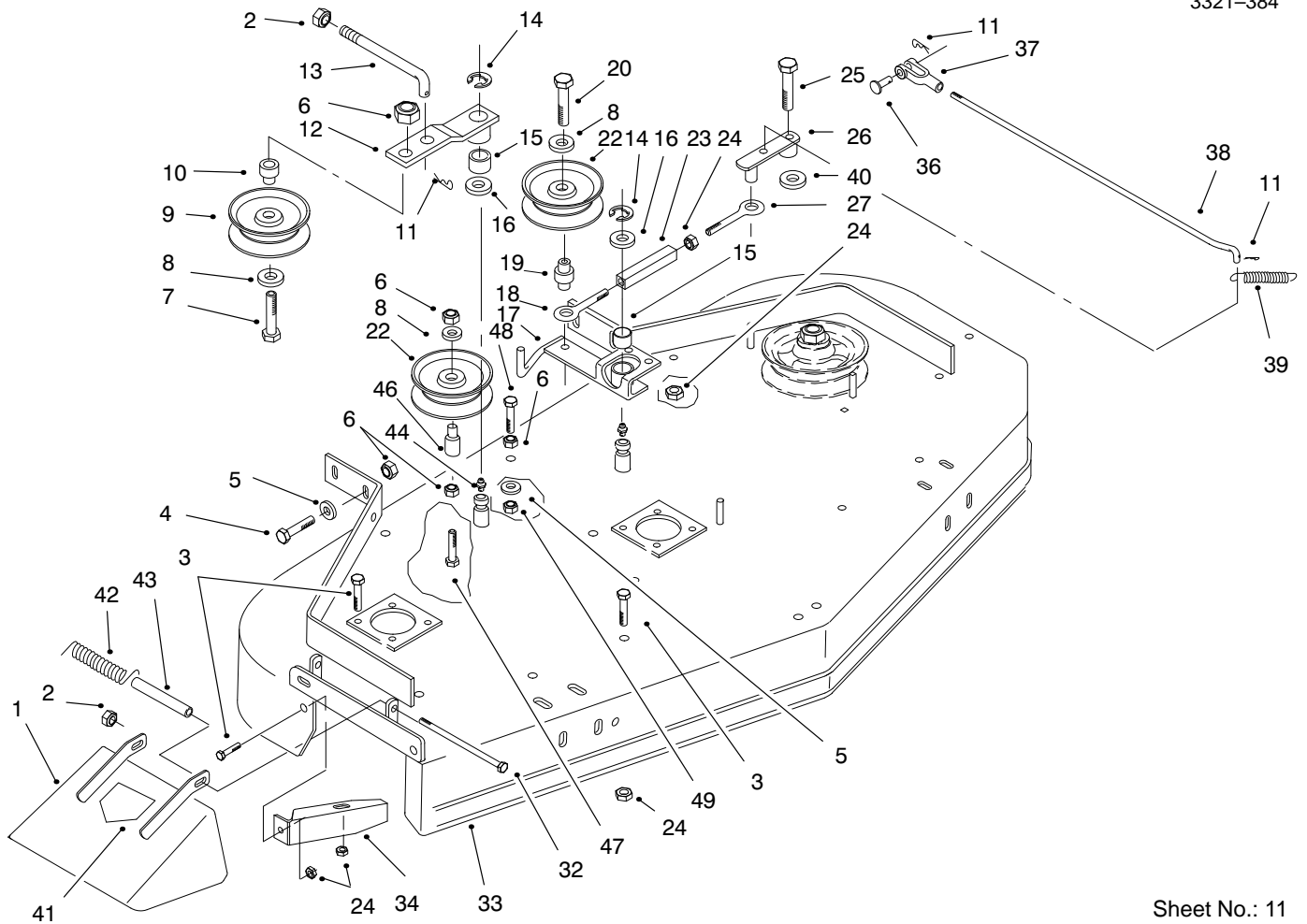

Sheet No.: 11

## Deck, Drive Pulleys And Deflector

Ref. No.	Part No.	Qty.	Description
1	E404245	1	Discharge Chute w/Decal
2	3296-29	2	Nut-Lock
3	E800270	10	Screw-HH
4	323-7	6	Screw-HH
5	E303327	7	Washer-Lock
6	32128-43	10	Nut-Flange
7	323-9	1	Screw-HH
8	3256-24	3	Washer-Flat
9	E403119	1	Pulley-Idler
10	E603496	1	Bushing
11	3290-307	3	Pin-Cotter
12	E402053	1	Idler Arm Assembly
13	E403107	1	Rod-Tension
14	E808505	2	Ring-Retaining
15	E303144	2	Bearing
16	E303352	2	Washer-Spindle
17	E324344	1	Engagement Arm w/Bushing
18	E303348	1	Eye Bolt
19	E303434	1	Bushing
20	E803003	1	Bolt-Whizlock
22	E603843	2	Pulley-Idler
23	E303236	1	Turnbuckle Body
24	32128-20	12	Nut-Lock
25	E809084	1	Bolt-Shoulder

Ref. No.	Part No.	Qty.	Description
26	E322211	1	Assist Arm ASM
27	E303238	1	Eye Bolt
32	E800291	1	Screw-HH
33	E404244	1	Deck ASM w/ Decals
34	E402107	1	Baffle Weldment
36	E808280	1	Pin-Clevis
37	E303105	1	Yoke
38	E323303	1	Linkage-Assist Arm
39	E323608	1	Spring-Extension
40	80-4980	1	Washer
41	93-1122	1	Decal-Danger
42	E323575	1	Spring-Deflector
43	E323636	1	Spacer-Spring
44	302-58	2	Fitting-Grease
46	E543879	1	Bushing
47	E800029	1	TAP Bolt
48	323-13	1	Screw-HH
49	32146-2	1	Nut-Hex Lock







# Toro Part Number Index

Part No.	Page No.	Ref. No.	Qty.	Description
614672	5	45	1	Bolt-Shoulder
740275	5	41	1	Switch-Bail
E302194	6	12	2	Support-Caster
E303020	2	5	1	Grip
E303020	5	47	1	Grip
E303077	1	7	5	Clamp
E303105	7	37	1	Yoke
E303125	4	31	2	Tire
E303144	7	15	2	Bearing
E303186	2	12	1	Bell Crank
E303197	1	6	1	Filter
E303236	7	23	1	Turnbuckle Body
E303238	7	27	1	Eye Bolt
E303308	1	4	1	Clamp
E303314	6	13	8	Spacer
E303327	2	9	1	Washer-Lock
E303327	4	2	4	Washer-Lock
E303327	7	5	7	Washer-Lock
E303334	1	27	4	Washer-Lock
E303348	7	18	1	Eye Bolt
E303352	7	16	2	Washer-Spindle
E303431	1	21	1	Elbow
E303434	7	19	1	Bushing
E303471	1	5	1	Fuel Line-12 Inch
E303514	6	11	4	Bearing-Flanged
E303536	6	4	3	Stud-Belt Shield(Long)
E303537	6	9	2	Stud-Belt Shield(Short)
E303558	9	21	2	Pulley
E304259	5	30	1	Control Panel ASM
E322110	1	26	3	Guide-Belt
E322125	4	13	2	Swivel
E322145	6	20	2	Fork
E322201	2	53	1	Deck-Engine
E322205	4	8	1	Idler Arm ASM LH
E322206	4	9	1	Idler Arm ASM RH
E322207	5	6	1	Pivot-Control
E322208	5	4	1	Bail ASM
E322209	4	24	2	Brake Arm ASM
E322211	7	26	1	Assist Arm ASM
E322212	4	41	1	Axle ASM
E322215	5	1	1	Control Bar
E322216	5	9	1	Upper Handle ASM
E323228	1	25	3	Spacer
E323252	2	23	2	Bearing
E323253	4	29	4	Sheave
E323254	2	24	2	Flange
E323256	2	28	1	Sheave
E323257	2	25	2	Sheave
E323260	4	37	8	Spacer
E323261	4	38	2	Drum-Brake
E323278	2	48	1	Sheave
E323285	2	35	1	Idler Pulley
E323296	4	12	2	Brake Rod
E323303	7	38	1	Linkage-Assist Arm
E323307	4	26	4	Pin
E323318	2	51	2	Hitch Bracket
E323326	1	22	1	Nipple
E323329	4	35	4	Bearing
E323360	4	32	2	Wheel ASM w/Bearings
E323379	2	10	1	Washer
E323385	6	6	5	Knob
E323387	2	4	1	Shifter Plate

\*Not Illustrated

# Toro Part Number Index (cont.)

Part No.	Page No.	Ref. No.	Qty.	Description
E323389	2	2	2	Leg- Shifter Lever
E323399	9	23	2	Spacer
E323399	10	21	1	Spacer
E323417	6	8	5	Washer
E323502	2	43	2	Output Shaft
E323515	9	3	2	Blade-High Lift
E323515	10	3	1	Blade-High Lift
E323528	9	15	2	Spacer
E323528	10	15	1	Spacer
E323529	9	5	2	Tube Spindle Short
E323530	10	5	1	Tube-Spindle Long
E323532	9	25	2	Housing
E323532	10	13	1	Housing
E323533	9	7	2	Spacer
E323533	10	7	1	Spacer
E323538	10	18	1	Spacer-Sheave/Bearing
E323539	9	4	8	Spacer
E323539	10	4	4	Spacer
E323551	1	18	1	Tank
E323558	5	40	1	Decal-Parking Brake
E323560	2	54	1	Decal-Ground Speed
E323561	6	7	1	Decal-Proline 48
E323562	3	57	1	Decal-Caution
E323563	5	50	1	Decal-Blade Engagement
E323564	5	35	1	Decal-Panel
E323567	5	27	1	Wire Harness-Kawasaki
E323569	5	37	2	Rod-Control
E323570	2	6	1	Lever-Shift
E323573	5	48	1	Lever-Blade Engagement
E323574	4	22	2	Spring-Extension
E323575	7	42	1	Spring-Deflector
E323576	5	44	1	Linkage-Blade Drive
E323594	6	1	1	Decal-Belt Routing
E323595	4	23	2	Band-Brake
E323600	8	6	1	Rod-Brake
E323601	8	2	1	Rod-Brake
E323607	4	46	1	Shield-Trailing
E323608	7	39	1	Spring-Extension
E323614	5	39	1	Lever-Parking Brake
E323630	2	46	1	Belt-Trans Drive
E323631	4	43	2	Belt-Drive
E323632	4	19	2	Shield
E323634	4	14	2	Idler-Wheel Drive
E323636	7	43	1	Spacer-Spring
E323637	5	23	1	Throttle Control
E323659	6	29	1	Decal-Torque
E323680	2	42	2	Coupling
E323694	4	18	4	Spacer
E324305	8	1	2	Brake ASM
E324344	7	17	1	Engagement Arm w/Bushing
E402053	7	12	1	Idler Arm Assembly
E402107	7	34	1	Baffle Weldment
E403087	2	32	1	Pulley
E403107	7	13	1	Rod-Tension
E403119	7	9	1	Pulley-Idler
E403149	9	3	2	Blade-Low Lift
E403149	10	3	1	Blade-Low Lift
E403163	6	3	1	Belt-Blade Drive
E403164	6	2	1	Belt-Blade Drive
E403167	10	20	1	Sheave-Double Groove
E404244	7	33	1	Deck ASM w/ Decals
E404245	7	1	1	Discharge Chute w/Decal

\*Not Illustrated

# Toro Part Number Index (cont.)

Part No.	Page No.	Ref. No.	Qty.	Description
E404246	6	5	1	Belt Cover w/Decal
E412358	4	42	2	Scraper
E513016	9	11	4	Bearing
E513016	10	11	2	Bearing
E513152	2	15	1	Switch-Seat
E513208	9	2	2	Washer-Lock
E513208	10	2	1	Washer-Lock
E513338	6	10	2	Washer
E513508	1	17	1	Cap-Fuel Tank
E513547	6	17	2	Spacer
E513645	1	12	1	Bushing
E513807	6	16:1	2	Wheel Hub ASM
E513808	6	16:2	2	Tire
E513809	6	16:3	2	Bearing-Roller
E513810	6	16:4	4	Bushing
E513959	4	11	2	Wingnut
E523157	4	33	A/R	Spacer-14 GA
E543233	1	23	1	Cap
E543277	1	11	1	Elbow
E543296	2	55	1	Grommet-Fuel Line
E543436	4	33	A/R	Spacer-18 GA
E543879	7	46	1	Bushing
E603403	2	13	1	Bolt-Shoulder
E603496	7	10	1	Bushing
E603770	1	9	1	Valve-Gas
E603776	1	8	1	Fuel-Line
E603843	7	22	2	Pulley-Idler
E603955	1	10	1	Fuel-Line
E633023	1	13	2	Stud
E633349	1	15	2	Spring-Fuel Tank
E633573	9	16	2	Guard
E633573	10	16	1	Guard
E634619	9	13	2	Housing-Spindle Incl
E634619	10	19	1	Housing-Spindle Incl
E800029	7	47	1	TAP Bolt
E800270	7	3	10	Screw-HH
E800291	7	32	1	Screw-HH
E800861	9	1	2	Screw-HH
E800862	10	1	1	Screw-Hhcs
E803003	7	20	1	Bolt-Whizlock
E803028	2	16	2	Screw
E803051	4	28	4	Nut
E803293	2	47	2	Screw-Set
E803310	2	27	3	Screw-Set
E803310	9	22	2	Screw-Set
E803310	10	23	1	Screw-Set
E807009	2	44	3	Key
E807264	2	29	1	Key
E807267	9	6	2	Key
E807267	10	6	1	Key
E807511	2	17	1	Bolt-CARR
E808280	7	36	1	Pin-Clevis
E808501	4	27	2	Ring-Retaining
E808502	9	20	2	Ring-Retaining
E808502	10	8	1	Ring-Retaining
E808505	7	14	2	Ring-Retaining
E808519	4	34	2	Ring-Retaining
E808522	4	6	2	Ring
E808523	2	45	2	Ring-Retaining
E809020	6	14	2	Pin
E809065	1	28	3	Screw-HH
E809084	7	25	1	Bolt-Shoulder

\*Not Illustrated

# Toro Part Number Index (cont.)

Part No.	Page No.	Ref. No.	Qty.	Description
E811001	6	23	2	Zerk
43-8480	6	28	1	Decal-Danger
47-2910	5	46	1	Washer-Thrust
51-4220	3	58	2	Guard-Coupler
63-8440	1	24	1	Decal-Hot Surface
66-1340	6	27	1	Decal-Discharge
67-0710	8	3	2	Ball - Swivel
67-5360	6	26	1	Decal-Danger
74-0521	4	10	2	Rod-Fitting
74-0720	5	31	1	Tube-Manual
80-4980	7	40	1	Washer
82-2280	5	7	1	Decal-Reverse
82-2290	5	2	1	Decal-Control Bar
93-1122	7	41	1	Decal-Danger
95-2814	3	56	1	Decal-Fuel Shut-Off
98-3269	6	25	1	Decal-Made In USA
218-595	5	38	1	Connector-Body
237-141	5	43	2	Grommet
2412-104	4	47	2	Clamp
2412-120	5	28	2	Clamp-R
283-6	4	49	2	Pin-Clevis
283-55	5	21	2	Pin-Clevis
302-58	2	49	2	Fitting-Grease
302-58	4	4	2	Fitting-Grease
302-58	7	44	2	Fitting-Grease
321-3	2	26	4	Screw-HH
322-3	1	20	2	Screw-HH
322-3	2	37	4	Screw-HH
322-3	8	5	4	Screw-HH
322-6	4	40	8	Screw-HH
323-4	6	22	8	Screw-HH
323-6	2	50	4	Screw-HH
323-6	4	3	4	Screw-HH
323-7	7	4	6	Screw-HH
323-7	9	9	12	Screw-HH
323-7	10	9	6	Screw-HH
323-9	7	7	1	Screw-HH
323-11	4	5	2	Screw
323-13	7	48	1	Screw-HH
323-16	4	20	4	Screw-HH
325-20	6	15	2	Screw-HH
3210-3	4	45	2	Screw-HH
3217-9	6	18	2	Nut-HH
3219-6	9	24	2	Nut-Hex
3219-6	10	22	1	Nut-Hex
3230-1	2	3	21	Bolt-CARR
3234-11	5	33	4	Screw-HHF
3242-4	2	30	1	Screw-Set
3242-6	2	31	1	Screw-Sqh Set
3253-4	1	19	2	Washer-Lock
3253-4	2	38	4	Washer-Lock
3253-4	4	39	8	Washer-Lock
3253-7	6	19	2	Washer-Lock
3256-2	1	14	4	Washer-Flat
3256-23	4	51	2	Washer-Flat
3256-24	2	34	1	Washer-Flat
3256-24	5	51	1	Washer-Flat
3256-24	7	8	3	Washer-Flat
3256-25	2	36	2	Washer-Flat
3290-307	2	52	1	Pin-Cotter
3290-307	4	25	2	Pin-Cotter
3290-307	4	50	2	Pin-Cotter

\*Not Illustrated

# Toro Part Number Index (cont.)

Part No.	Page No.	Ref. No.	Qty.	Description
3290-307	5	42	3	Pin-Cotter
3290-307	7	11	3	Pin-Cotter
3290-378	5	26	2	Tie-Cable
3296-2	5	3	5	Nut-Lock
3296-6	2	8	1	Nut-Lock
3296-29	1	16	2	Nut-Lock
3296-29	7	2	2	Nut-Lock
3296-29	8	4	4	Nut-Lock
3296-42	8	7	2	Nut-Lock
32104-32	2	11	4	Screw-HH
32104-76	5	29	2	Screw-Self TAP
32105-1	5	5	1	Screw-HH
32105-14	5	34	4	Screw-HH
32128-20	2	7	2	Nut-Lock
32128-20	6	30	5	Nut-Lock
32128-20	7	24	12	Nut-Lock
32128-21	5	32	4	Nut-HF
32128-43	2	41	5	Nut-Flange
32128-43	4	1	14	Nut-Flange
32128-43	6	24	8	Nut-Flange
32128-43	7	6	10	Nut-Flange
32146-2	2	33	1	Nut-Hex Lock
32146-2	5	49	1	Nut-Hex Lock
32146-2	7	49	1	Nut-Hex Lock
32146-2	9	14	12	Nut-Hex Lock
32146-2	10	14	6	Nut-Hex Lock
32146-4	4	48	2	Nut-Lock
32146-17	2	39	4	Nut-Lock
32146-18	2	14	2	Nut-Lock
32151-80	5	8	2	Ring-Push On
33114-025	1	3	1	Screw-HH

