



Z-Master

Z325 OFZ Traction Unit

Model No. 74182 – 891200 & Up

Parts Catalog

ORDERING REPLACEMENT PARTS

To order replacement parts, please supply: the part number, the quantity, and the description of each part desired.

Contents

Description	Page	Description	Page
Frame & Wheels	1	Crankcase	15
Engine & Fuel Tank	2	Oil Pan / Lubrication	16
Electrical System	3	Head / Valve / Breather	17
Parking Brake	4	Ignition / Electrical	18
Hydraulic System	5	Blower Housing & Baffles	19
Hydraulic System	6	Starting System	20
Seat And Fenders	7	Fuel System	21
Seat And Fenders	8	Engine Controls	22
Steering Controls	9	Air Intake	23
Heat Shields And Exhaust	10	Exhaust	24
Drive Systems	11	Gear Box Assembly No. 94-4641	25
Electric Schematic	12	Hydraulic Pump Assembly	
Hydraulic Schematic	13	No. 98-4374 and 98-4375	26
Crankshaft	14		

Part Description Abbreviations

Part descriptions in this catalog may include the following abbreviations.

Abbreviation	Meaning	Abbreviation	Meaning
AR	as required	HWHTF	hex washer head thread forming
ASM	assembly	INC	incorporated
CARR	carriage	LH	left hand
DEG	degrees	PH	pan head
FH	flat head	PPH	Phillips pan head
GA	gauge	PTO	power take off
HF	hex flange	RH	right hand
HFW	hex flange washer	SFH	slotted fillister head
HH	hex head	SH	square head
HHF	hex head flange	SHWH	slotted hex washer head
HHST	hex head self tapping	SPH	slotted pan head
HJ	hex jam	STD	standard
HOC	height-of-cut	TAP	self tapping
HS	hex socket	TH	truss head
HSBH	hex socket button head	TTH	Torx truss head
HSFH	hex socket flat head	WH	wing head
HSH	hex socket head		
HWH	hex washer head		

Important Format Explanations

This catalog uses special formats to convey information in illustrations and parts lists. Specifically, one format is used in conjunction with service assemblies and another with quantities associated with reference numbers.

Service Assemblies

Parts within service assemblies have reference numbers in the form $X:Y$. X is the reference number of the service assembly and Y is a sequential number unique to each part within the service assembly.

For example, a wheel assembly might be identified by reference number 6, the tire by 6:1, the valve by 6:2, and the wheel by 6:3. When you order the assembly identified by reference number 6, you receive all parts identified by reference numbers 6:1, 6:2, and 6:3. However, you may also order any part individually.

Reference numbers of this type appear in part lists and as callouts in illustrations.

Reference Numbers with Quantities

Illustrations may have a quantity in parentheses next to a reference number, in the form $X (Y)$. X is the reference number. Y in parentheses is the quantity of the part identified by the reference number.

For example, the illustration callout 4 (2) indicates that two parts are used in that instance.

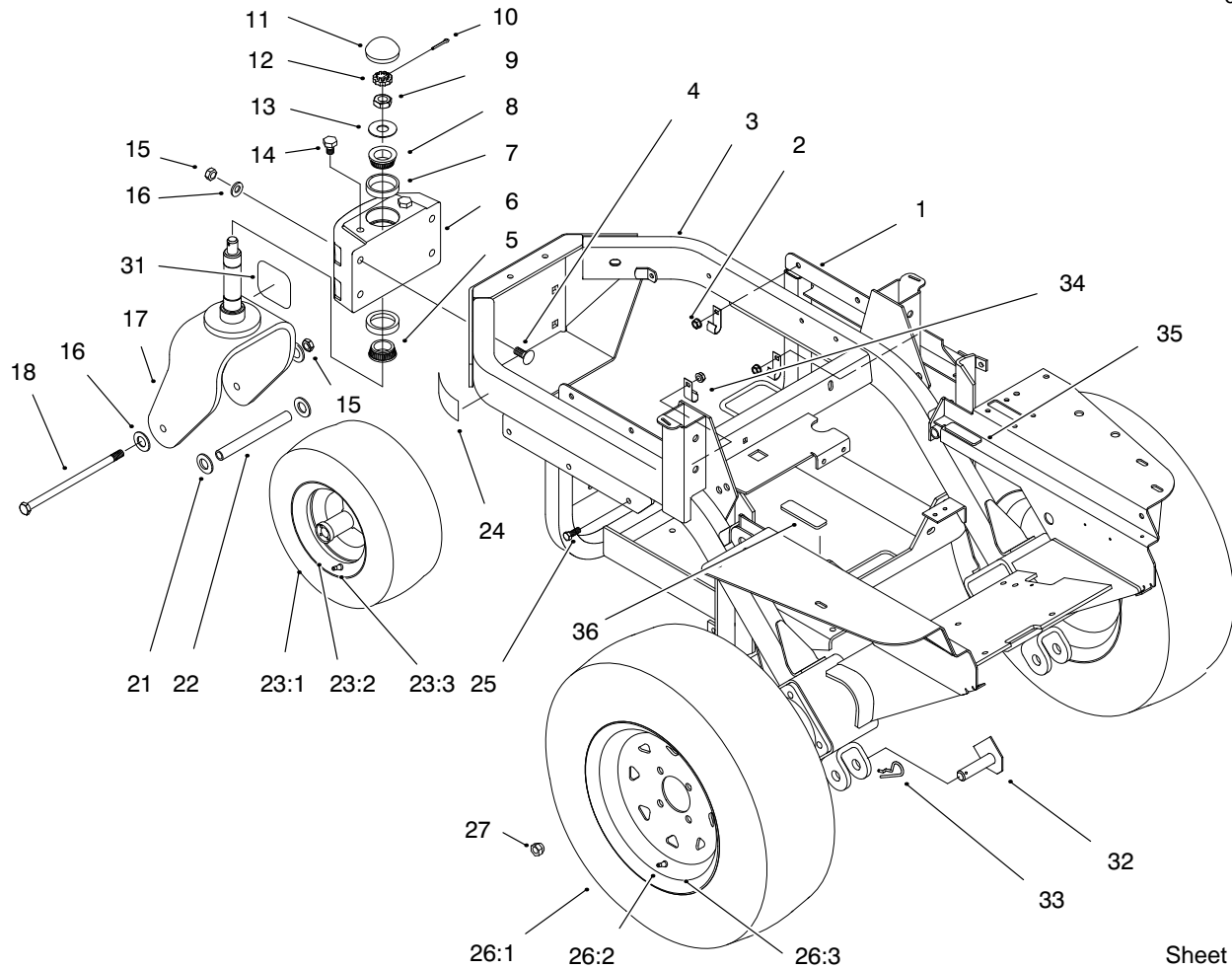

Sheet No.: 2

Frame & Wheels

Ref. No.	Part No.	Qty.	Description
1	94-4618-03	1	Support-Engine
2	3296-39	6	Nut-Lock
3	94-9598	1	Frame ASM
4	3233-27	4	Screw-CARR
5	254-70	1	Cone-Bearing & Seal
6	94-9489-01	1	Housing-Spindle
7	254-61	2	Cup-Bearing
8	254-62	1	Cone-Bearing
9	3220-7	1	Nut-Jam
10	3272-17	1	Pin-Cotter
11	94-4665	1	Dustcap
12	93-0307	1	Nut-Lock
13	3256-8	1	Washer-Flat
14	325-2	2	Screw
15	3296-23	5	Nut-Lock
16	3256-26	6	Washer-Flat
17	94-4647-01	1	Castor Fork
18	325-24	1	Screw-HH
19	98-4383	1	Decal-Patent Numbers
21	3256-39	2	Washer-Flat
22	94-4753	1	Tube-Spacer
23:1	94-9384	1	Tire
23:2	98-4351	1	Rim
23:3	232-27	1	Valve Stem
24	93-9198	1	Decal-Warning

Ref. No.	Part No.	Qty.	Description
25	323-6	6	Screw-HH
26:1	94-9388	2	Tire
26:2	232-27	2	Valve Stem
26:3	94-9385	2	Wheel
27	242-50	8	Nut-Lug
31	95-1957	1	Decal-Z325
32	94-4755	2	Pivot Pin ASM
33	3290-343	2	Pin-Hair
34	8830	1	Retainer-”J”
35	52-5260	2	Rubber Pad
36	98-4361	1	Decal-Warning

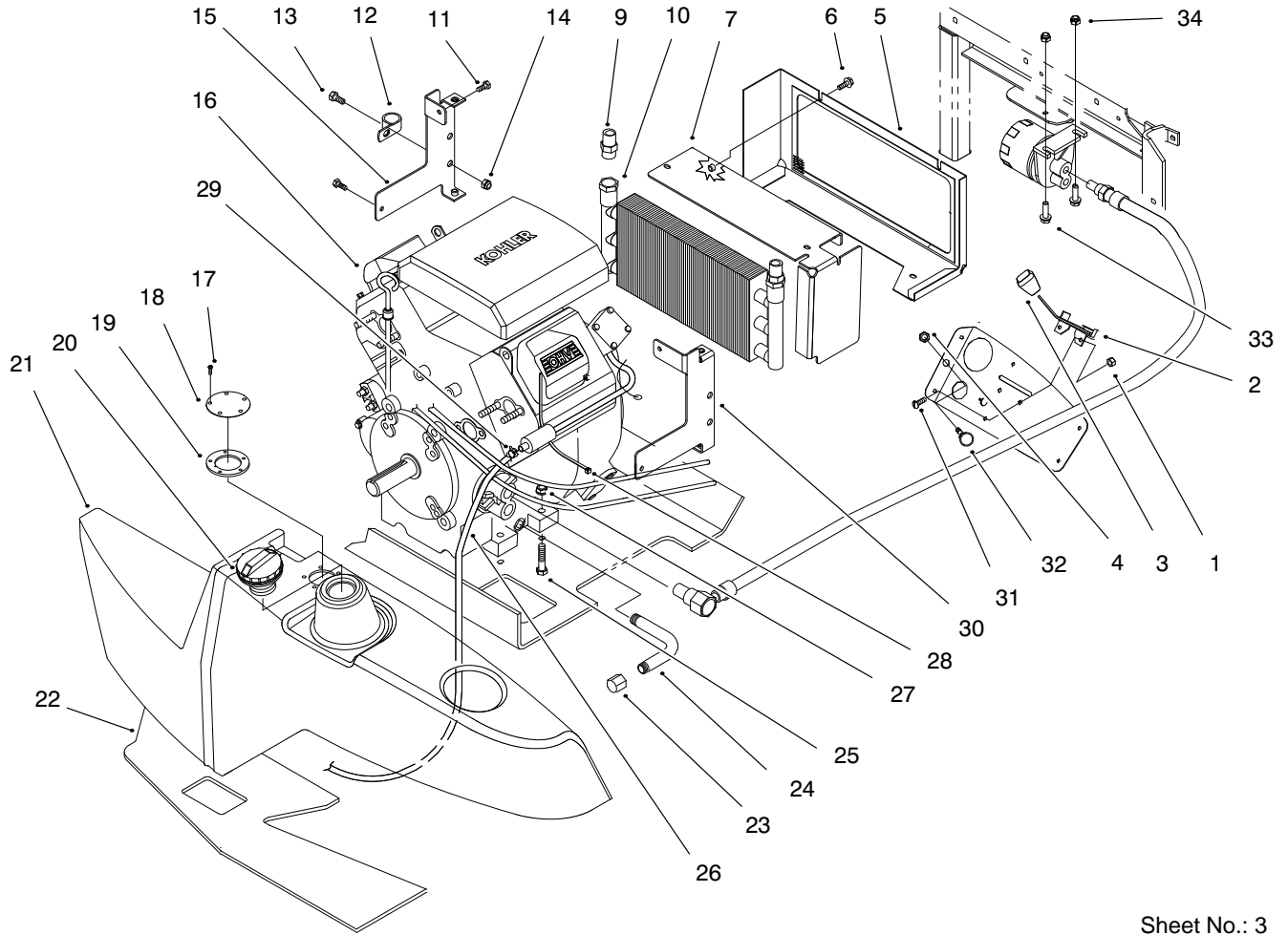

Sheet No.: 3

Engine & Fuel Tank

Ref. No.	Part No.	Qty.	Description
1	3296-2	2	Nut-Lock
2	98-4350	1	Control-Throttle
3	66-0120	1	Knob
4	3220-3	1	Nut-Hex Jam
5	94-9556-03	1	Cooler Shroud ASM
6	3234-4	6	Screw-HH
7	98-1969-03	1	Cooler Shroud ASM
9	93-5107	2	Fitting-Adapter
10	24-0760	1	Exchanger-Heat
11	32144-10	2	Screw-HH
12	2412-39	4	R-Clamp
13	322-3	4	Screw-HH
14	3296-29	4	Nut-Lock
15	98-1972-03	1	Bracket-Rear
16	99-0264	1	Engine-Kohler
17	3250-29	5	Screw
18	94-9597-03	1	Cover-Fuel Tank Opening
19	62-7650	1	Gasket
20	93-3101	1	Gas Cap
21	94-9553	1	Fuel Tank ASM
22	98-1319	1	Foam-Tank
23	288-4	1	Cap-Pipe
24	94-9499	1	Tube-Oil Drain
25	323-9	4	Screw-HH
26	98-0976	1	Hose-Fuel

Ref. No.	Part No.	Qty.	Description
27	3296-39	4	Nut-Lock
28	3290-378	A/R	Tie-Cable
29	2412-98	2	Clamp-Hose
30	98-1970-03	1	Bracket-Front
31	3250-13	2	Screw-PPH
32	98-1956	1	Control-Push Pull
33	3234-17	2	Screw-Hfh
34	3296-29	2	Nut-Lock

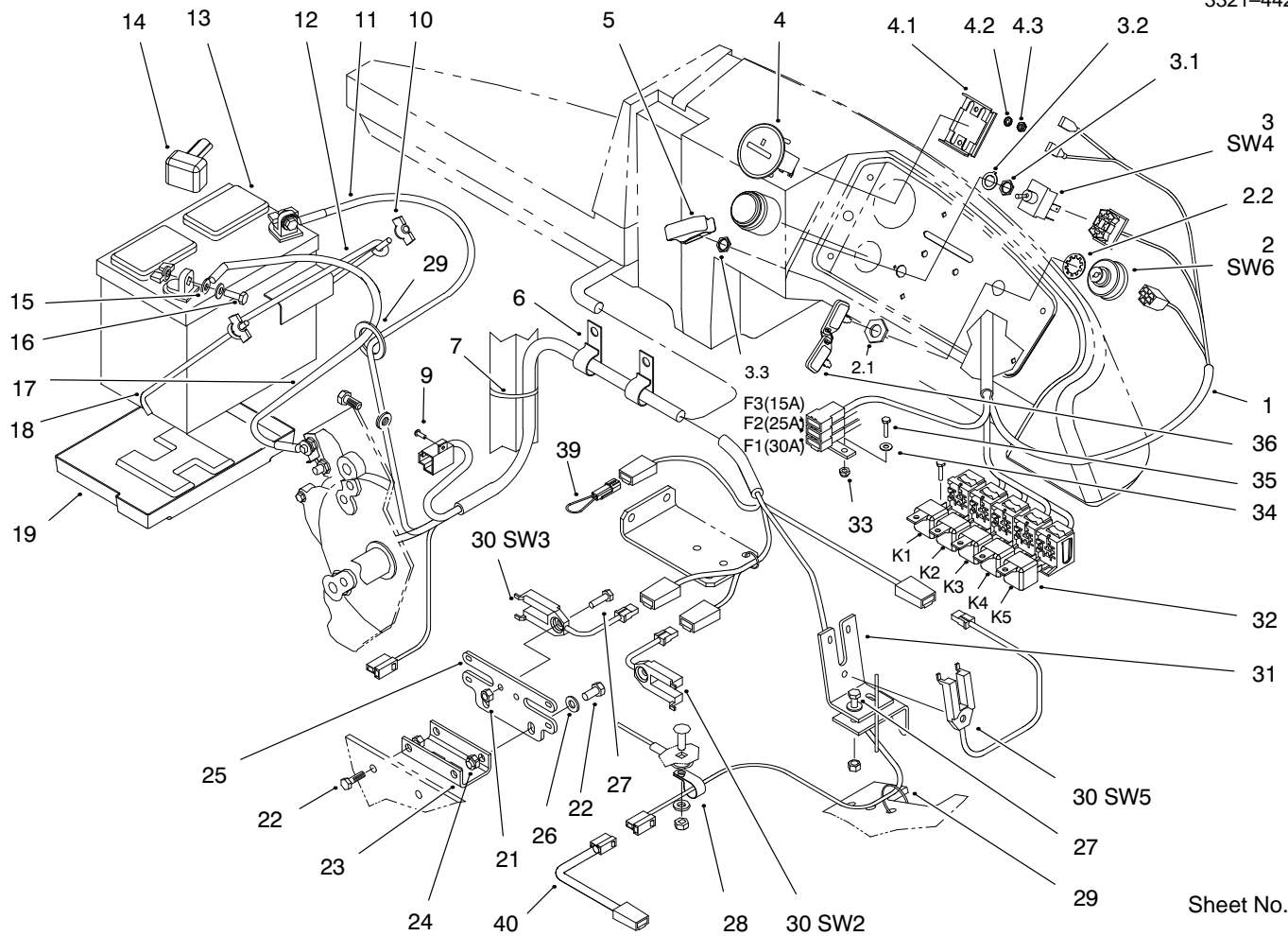

Sheet No.: 4

Electrical System

Ref. No.	Part No.	Qty.	Description
1	98-3317	1	Harness-Wire
2	111216	1	Switch-Ignition
2:1	101884	2	Nut-Hex
2:2	9201604	1	Washer-Lock
3	92-9811	1	Switch-Toggle
3:1	105805	1	Nut
3:2	102950	1	Washer
3:3	113179	1	Nut
4	78-0020	1	Hourmeter
4:1	78-3320	1	Clamp-Hour Meter
4:2	3255-25	2	Washer-Lock
4:3	3217-27	2	Nut-HH
5	113050	1	Cover-Switch
6	94-9580	2	Clamp-J
7	3290-379	A/R	Tie-Cable
9	32144-74	2	Screw
10	32103-22	4	Nut-Wing
11	92-6287	1	Wire-Ground
12	113010	1	Hold Down
13	94-6666	1	ASM-Battery/Decal
14	28-8080	1	Boot-Terminal (Red)
15	3256-22	4	Washer-Flat
16	321-4	2	Screw-HH
17	28-3893	1	ASM-Wire
18	94-6146	2	Retainer-Battery
19	106948	1	Tray-Battery

Ref. No.	Part No.	Qty.	Description
21	3296-42	5	Nut-Lock
22	322-3	4	Screw-HH
23	94-4797-03	1	Channel-Mount Switch
24	3296-29	4	Nut-Lock
25	94-9460	1	Plate-Switch Mount
26	3256-23	2	Washer-Flat
27	321-4	5	Screw-HH
28	2412-93	1	R-Clamp
29	3290-378	A/R	Tie-Cable
30	98-1324	3	Switch-Interrupter
31	94-4696	1	Angle-Mount
32	116397	5	Relay
33	3296-2	3	Nut-Lock
34	3256-14	3	Washer-Flat
35	32105-13	3	Screw-HH
36	62-7770	2	Key-Ignition
39	98-1982	1	Jumper
40	98-4373	1	Harness-Adapter

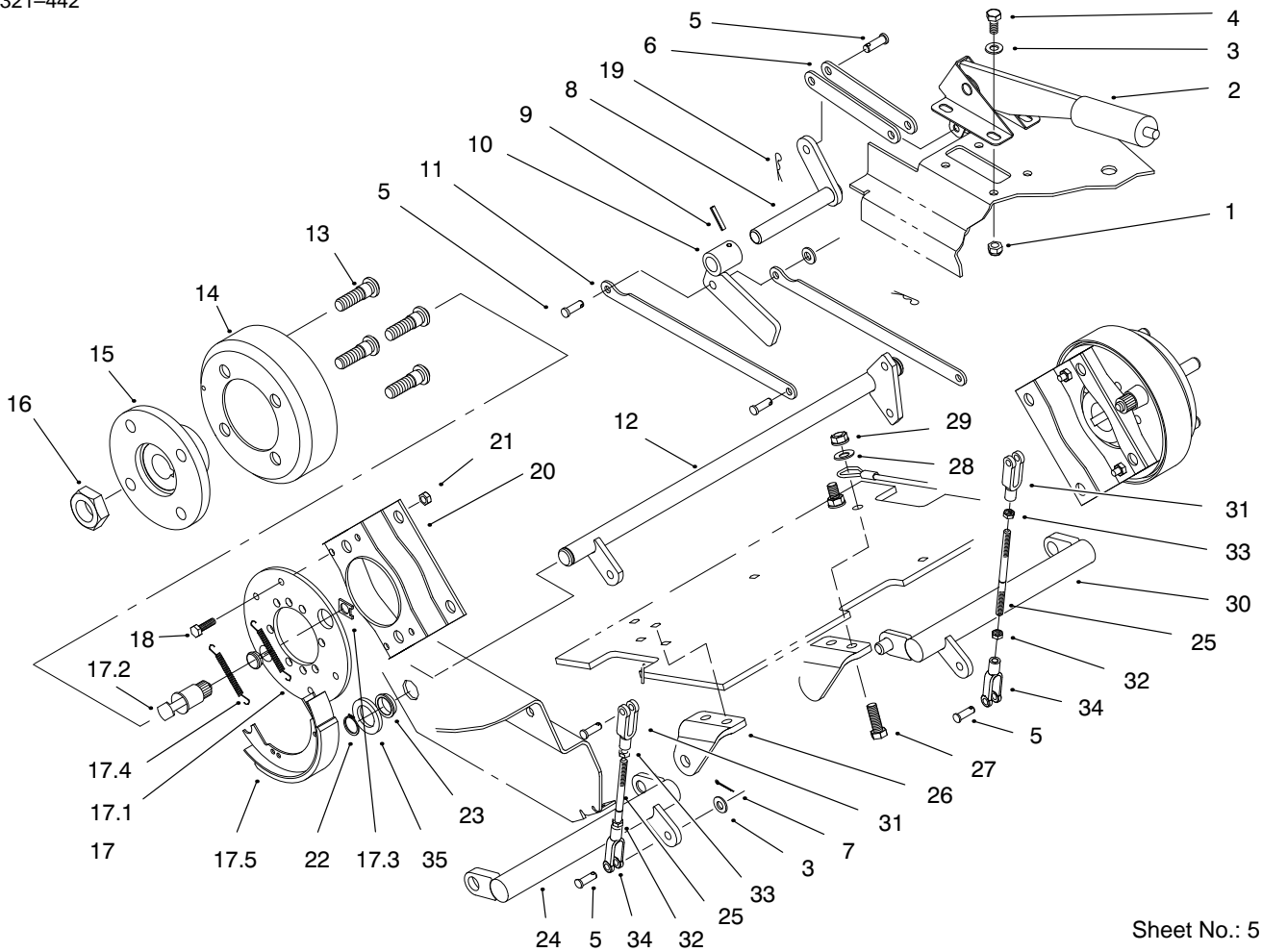

Sheet No.: 5

Parking Brake

Ref. No.	Part No.	Qty.	Description
1	3296-29	4	Nut-Lock
2	94-4602	1	Lever-Brake
3	3256-23	4	Washer-Flat
4	322-3	4	Screw-HH
5	283-1	8	Pin-Clevis
6	98-1992	2	Link-Brake
7	3272-10	2	Pin-Cotter
8	98-1990	1	Transfer Shaft ASM
9	32121-93	1	Pin-Spiral
10	98-1994	1	Brake Hub ASM
11	98-1991	2	Link-Connect
12	98-1988	1	Torsion Shaft ASM
13	85-6540	8	Stud
14	10-6850	2	Drum Brake
15	10-6870	2	Hub-Wheel
16	26-3790	2	Nut-Lock
17	71-1500	2	Brake ASM
17.1	70-9870	2	Plate-Backing
17.2	70-9860	2	Cam Shaft
17.3	70-9850	2	Clip-Retainer
17.4	70-9880	4	Spring-Return
17.5	70-9840	4	Brake Shoe
18	321-4	8	Screw-HH
19	3290-307	6	Pin-Hair
20	84-2000	2	Bracket-Brake
21	3296-42	8	Nut-Lock

Ref. No.	Part No.	Qty.	Description
22	32120-72	2	Ring-Retaining
23	106950	2	Bushing
24	98-1998	1	RH Brake Lever ASM
25	98-1996	2	Rod-Brake
26	94-9573-01	2	Mount-Lever
27	323-18	4	Screw-HH
28	3256-24	1	Washer-Flat
29	3296-39	4	Nut-Lock
30	98-1997	1	LH Brake Lever ASM
31	282-2	2	Clevis
32	3220-20	2	Nut-Hex Jam
33	3220-2	2	Nut-Jam
34	98-4367	2	Clevis-Adjustable
35	9202574	A/R	Washer-Flat

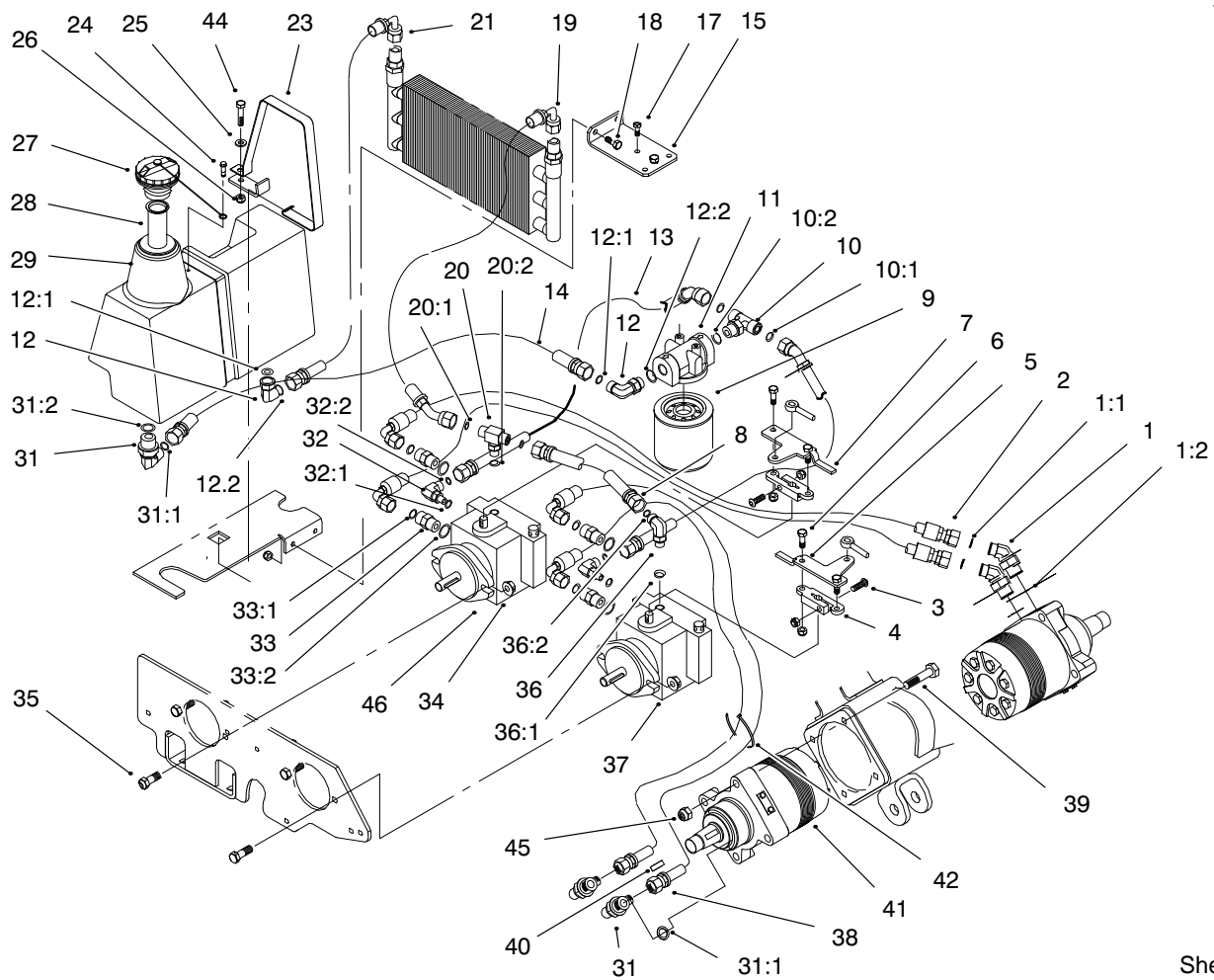

Sheet No.: 6

Hydraulic System

Ref. No.	Part No.	Qty.	Description
1	340-89	2	Fitting-Hydraulic
1:1	237-30	2	O-Ring
1:2	237-80	2	O-Ring
2	94-4714	2	Hose ASM-Hyd
3	3274-83	2	Screw-HSH
4	94-4678	2	Arm-Pump Control
5	94-4701-03	1	Plate-Control
6	322-5	4	Screw-HH
7	94-4702-03	1	Plate-Control
8	94-4712	1	Hose ASM-Hyd
9	67-8110	1	Filter-Oil
10	340-157	1	Fitting-Hydraulic
10:1	237-30	1	O-Ring
10:2	237-79	1	O-Ring
11	86-9080	1	Head-Filter
12	340-98	2	Fitting-Hyd
12:1	237-30	2	O-Ring
12:2	237-79	2	O-Ring
13	98-4384	2	Hose ASM - Hyd
14	94-4710	1	Hose ASM-Hyd
15	94-9525-03	1	Angle-Mount
17	3234-4	2	Screw-HH
18	32144-14	2	Screw-HWH
19	94-4713	1	Hose ASM-Hyd
20	340-94	1	Tee
20:1	237-22	2	O-Ring

Ref. No.	Part No.	Qty.	Description
20:2	237-42	1	O-Ring
21	94-4709	1	Hose ASM-Hyd
23	94-4642-03	1	Strap-Hydraulic Tank
24	3290-126	1	Screw-Hfh
25	3256-23	1	Washer-Flat
26	3296-29	7	Nut-Lock
27	93-4365	1	Oil Cap
28	92-1705	1	Screen-Filter
29	94-4700	1	Tank-Hydraulic
31	340-105	3	Fitting-Elbow
31:1	237-30	3	O-Ring
31:2	237-80	3	O-Ring
32	340-97	2	Fitting-Hydraulic
32:1	237-22	2	O-Ring
32:2	237-78	2	O-Ring
33	340-4	4	Fitting-Hyd
33:1	237-30	4	O-Ring
33:2	237-79	4	O-Ring
34	32128-42	4	Nut-Hex Flange
35	324-5	4	Screw-HH
36	340-77	1	Fitting-Hydraulic
36:1	237-22	1	O-Ring
36:2	237-42	1	O-Ring
37	98-4375	1	Pump-Hydraulic
38	94-4705	2	Hose ASM
39	3274-93	8	Screw-HSH

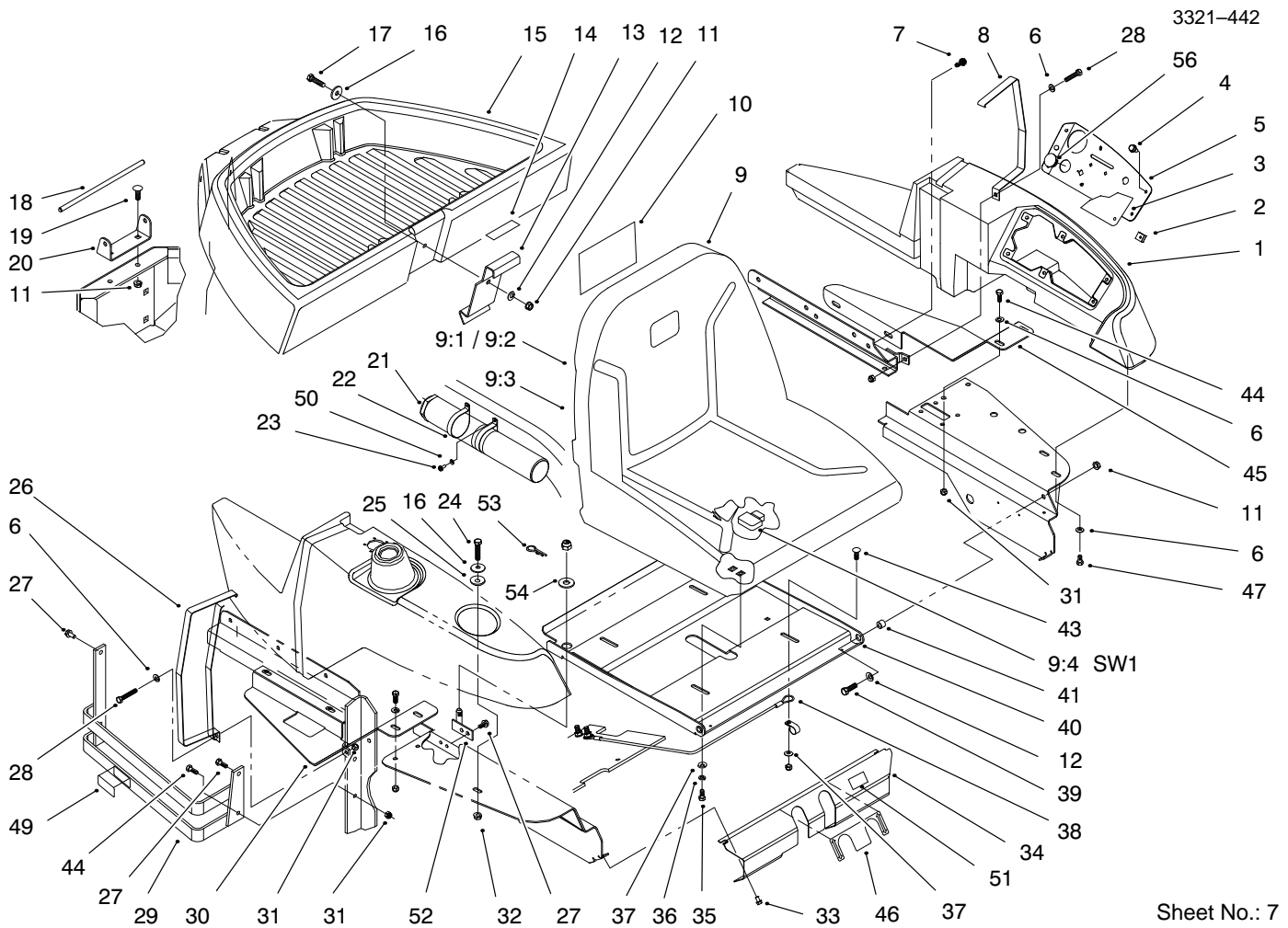

Sheet No.: 7

Seat And Fenders

Ref. No.	Part No.	Qty.	Description
1	94-4698	1	Console
2	95-1962	6	Clip
3	98-4357	1	Decal-Instrument
4	32144-124	6	Screw-PPH
5	98-1999-03	1	Panel-Instrument
6	3256-23	8	Washer-Flat
7	32144-11	4	Screw-TAP
8	94-9488-03	1	Strap-Console
9	92-6280	1	Seat ASM
9:1	92-6534	1	Shell-Seat
9:2	92-6533	1	Kit-Replacement Cushion
9:3	351-78	1	Edging
9:4	92-6282	1	Seat-Switch
*9:5	321-3	2	Screw-HH
*9:6	351-80	1	Edging Clip
10	93-7340	1	Decal-Toro
11	3296-39	5	Nut-Lock
12	3256-24	3	Washer-Flat
13	94-4672-03	1	Latch
14	98-1306	1	Decal-No Riders
15	94-4699	1	Box-Utility
16	63-8410	2	Washer-Flat
17	323-8	1	Screw-HH
18	94-9496	1	Pin-Pivot
19	3231-2	2	Screw-CARR

Ref. No.	Part No.	Qty.	Description
20	94-4721-03	1	Hinge
21	74-0720	1	Tube-Manual
22	2412-120	2	Clamp-R
23	3269-8	2	Rivet
24	323-9	1	Screw-HH
25	240-11	1	Grommet
26	94-4799-03	1	Strap-Fuel Tank
27	32144-14	4	Screw-HWH
28	322-10	2	Screw-HH
29	98-1995	1	Bumper
30	94-4798-01	1	Plate-Tank Support
31	3296-29	9	Nut-Lock
32	3290-357	1	Nut-Lock Flange
33	32144-4	4	Screw-TAP
34	94-9491-01	1	Plate-Cover
35	322-3	4	Screw-HH
36	3253-4	4	Washer-Lock
37	3256-2	5	Washer-Flat
38	98-4371	1	Cable-Seat
39	323-7	2	Screw-HH
40	94-9529-01	1	Plate-Seat
41	52-2480	2	Spacer
43	3230-2	1	Screw-CARR
44	322-4	6	Screw-HH
45	94-4635-01	1	Plate-Console Support

* Not illustrated

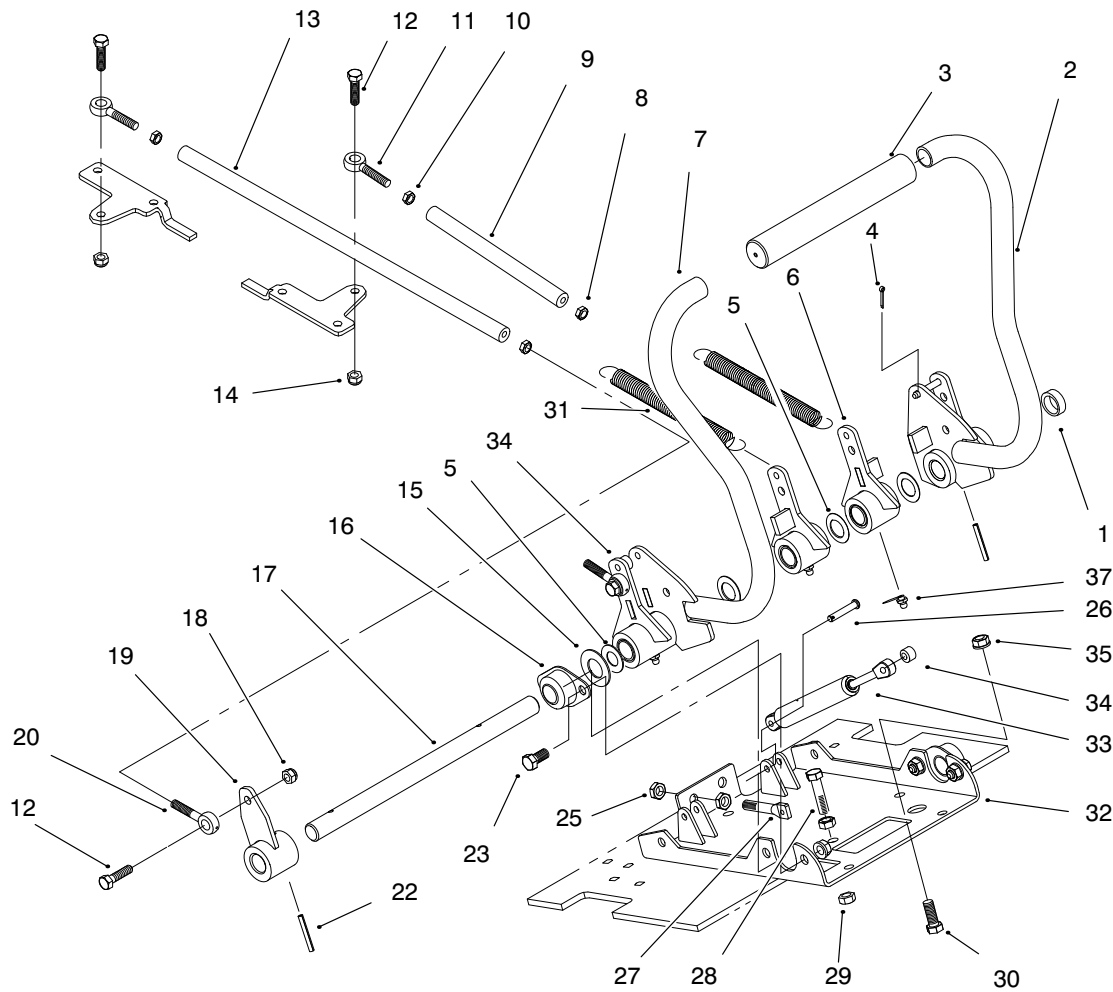

Sheet No.: 8

Steering Controls

Ref. No.	Part No.	Qty.	Description
1	94-9524	1	Spacer-Control
2	94-9517-03	1	Handle-Control LH
3	94-9490	2	Grip-Cushion
4	3272-4	4	Pin-Cotter
5	9202574	A/R	Washer-Flat
6	94-9552	2	Center Control ASM
7	94-9551	1	Handle-Control RH
8	3220-20	2	Nut-Hex Jam
9	94-4717	1	Rod-Control
10	3220-2	2	Nut-Jam
11	2411-52	2	Rod-End RH
12	322-5	4	Screw-HH
13	94-4718	1	Rod-Control
14	3296-29	2	Nut-Lock
15	3256-39	1	Washer-Flat
16	27-2320	2	Bearing
17	94-9515	1	Shaft-Control
18	3296-47	2	Nut-Lock
19	94-9594-03	1	Hub-Control
20	2411-53	2	Rod-End LH
22	32121-103	2	Pin-Spring
23	323-4	4	Screw-HH
25	3218-3	4	Nut-HJ
26	283-66	4	Pin-Clevis
27	113697	2	Eye Bolt
28	323-8	2	Screw-HH

Ref. No.	Part No.	Qty.	Description
29	3217-7	4	Nut-Lock
30	323-6	3	Screw-HH
31	98-1322	2	Spring-Extension
32	94-9591-03	1	Mount-Channel
33	98-4397	2	Damper-Bidirectional
34	94-9593	2	Spacer-Damper
35	3296-39	7	Nut-Lock
37	302-5	3	Fitting-Grease

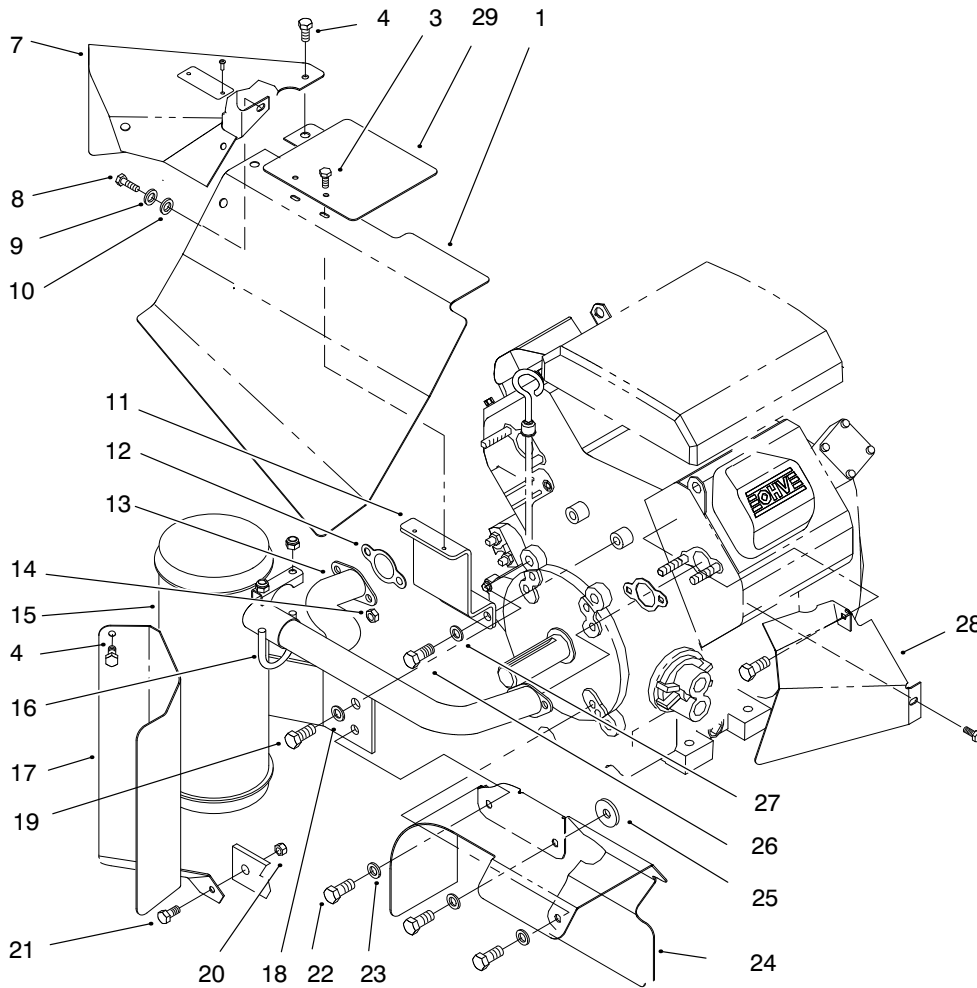

Sheet No.: 9

Heat Shields And Exhaust

Ref. No.	Part No.	Qty.	Description
1	98-1967	1	Top Heat Baffle ASM
*1:2	32148-6	3	Insert
3	12-5450	2	Screw-Thread Forming
4	3234-4	4	Screw-HH
7	98-1968	1	Rear Heat Baffle ASM
8	42-9430	1	Bolt w/Washer
9	48-8020	1	Washer-Lock
10	33093-00	1	Washer-Flat M6
11	94-9561-03	1	Bracket-Manifold Shield
12	93-0350	2	Gasket-Exhaust
13	94-9494	1	Manifold
14	92-6780	4	Nut-HHF
15	94-9495	1	Muffler
16	2112-11	1	Clamp-Muffler
17	98-1329	1	Baffle-Heat
18	3253-6	1	Washer-Lock
19	324-4	1	Screw-HH
20	3296-42	1	Nut-Lock
21	321-4	1	Screw-HH
22	323-5	3	Screw-HH
23	3253-5	3	Washer-Lock
24	98-1326	1	Baffle-Heat
25	2844	1	Washer-Flat
26	33114-020	2	Screw-HH

Ref. No.	Part No.	Qty.	Description
27	42-9850	2	Washer-Lock
28	98-1349	1	Baffle-Heat
29	98-1979	1	Panel-Access

* Not illustrated

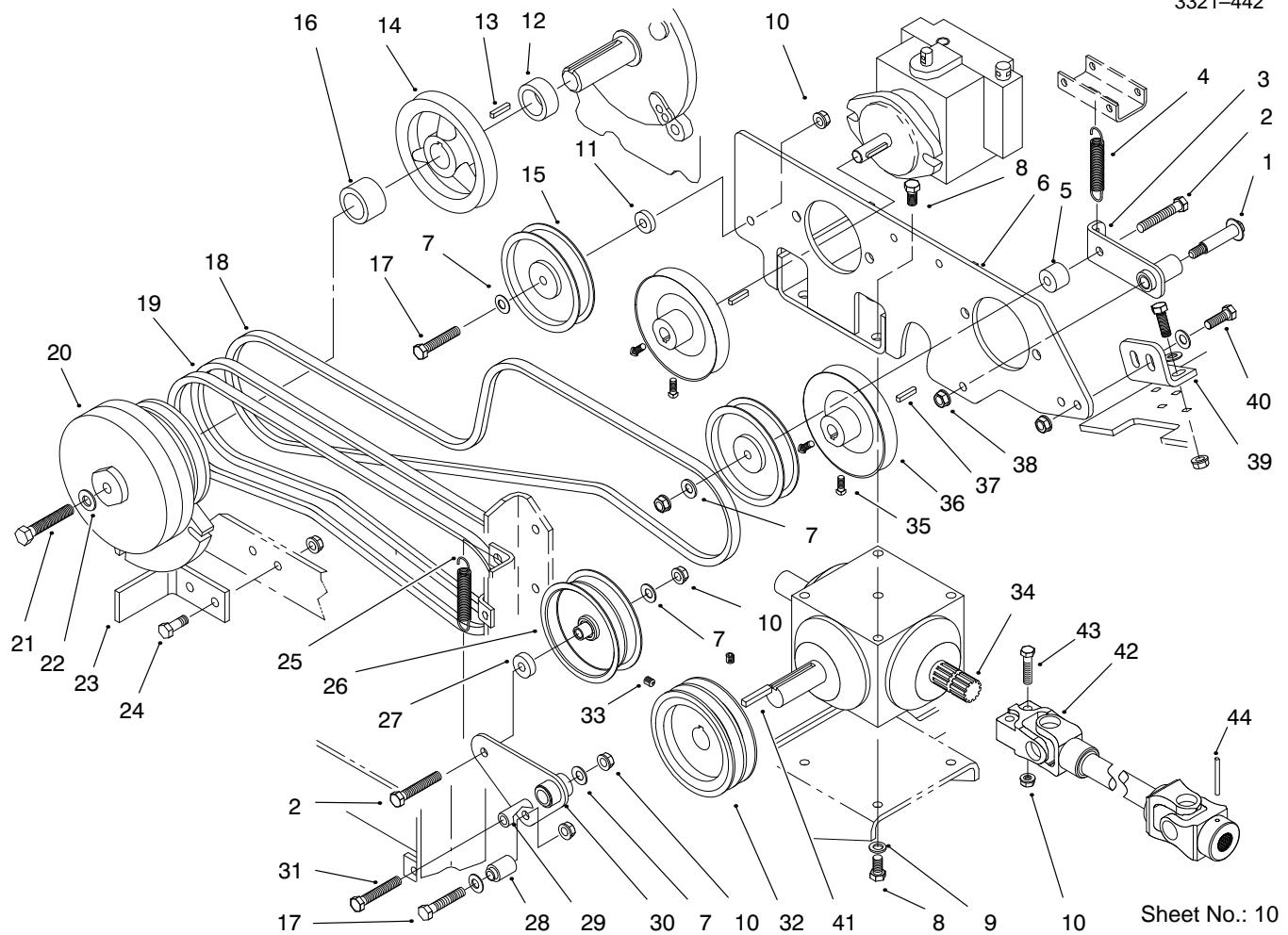

Sheet No.: 10

Drive Systems

Ref. No.	Part No.	Qty.	Description
1	27-6230	1	Bolt-Wheel
2	323-11	2	Screw
3	95-1950	1	Arm ASM
*3:2	256-154	2	Bushing-Straight
4	94-9599	1	Spring-Extension
5	94-4792	1	Spacer-Idler Arm
6	94-4658-03	1	Pump-Mount
7	3256-24	5	Washer-Flat
8	3234-1	8	Screw-HHF
10	3296-39	13	Nut-Lock
11	9202204	1	Washer
12	94-4688	1	Spacer-Engine Shaft
13	5-0698	1	Key
14	94-4628	1	Engine-Pulley
15	93-1622	2	Pulley-Idler
16	94-4689	1	Spacer-Engine Shaft
17	323-10	2	Screw-HH
18	94-4607	1	Belt-Pump Drive
19	94-4608	1	Belt-PTO
20	94-4632	1	Clutch ASM
21	3212-10	1	Screw
22	3256-25	1	Washer-Flat
23	98-1301-03	1	Stop-Clutch
24	323-6	2	Screw-HH
25	88-6460	1	Spring - Extension
26	66-4210	1	Pulley-Idler

Ref. No.	Part No.	Qty.	Description
27	94-4685	1	Spacer-Idler
28	95-1967	1	Spacer-Spring
29	114511	1	Spacer
30	95-1968	1	Idler Arm ASM
31	323-31	1	Screw-HHcs
32	94-4629	1	Clutch-Pulley
33	3246-3	2	Screw-HSH
34	94-4641	1	Gearbox-PTO Drive
35	3241-5	4	Set Screw
36	80-8170	2	Pulley-Pump
37	80-6090	2	Key-Square
38	3296-6	1	Nut-Lock
39	94-4787-03	1	Mount-Plate
40	3234-11	4	Screw-HHF
41	67-7490	1	Key
42	94-4722	1	Shaft-Drive
43	323-19	2	Screw-HH
44	32121-48	1	Pin-Roll

* Not illustrated

Electric Schematic

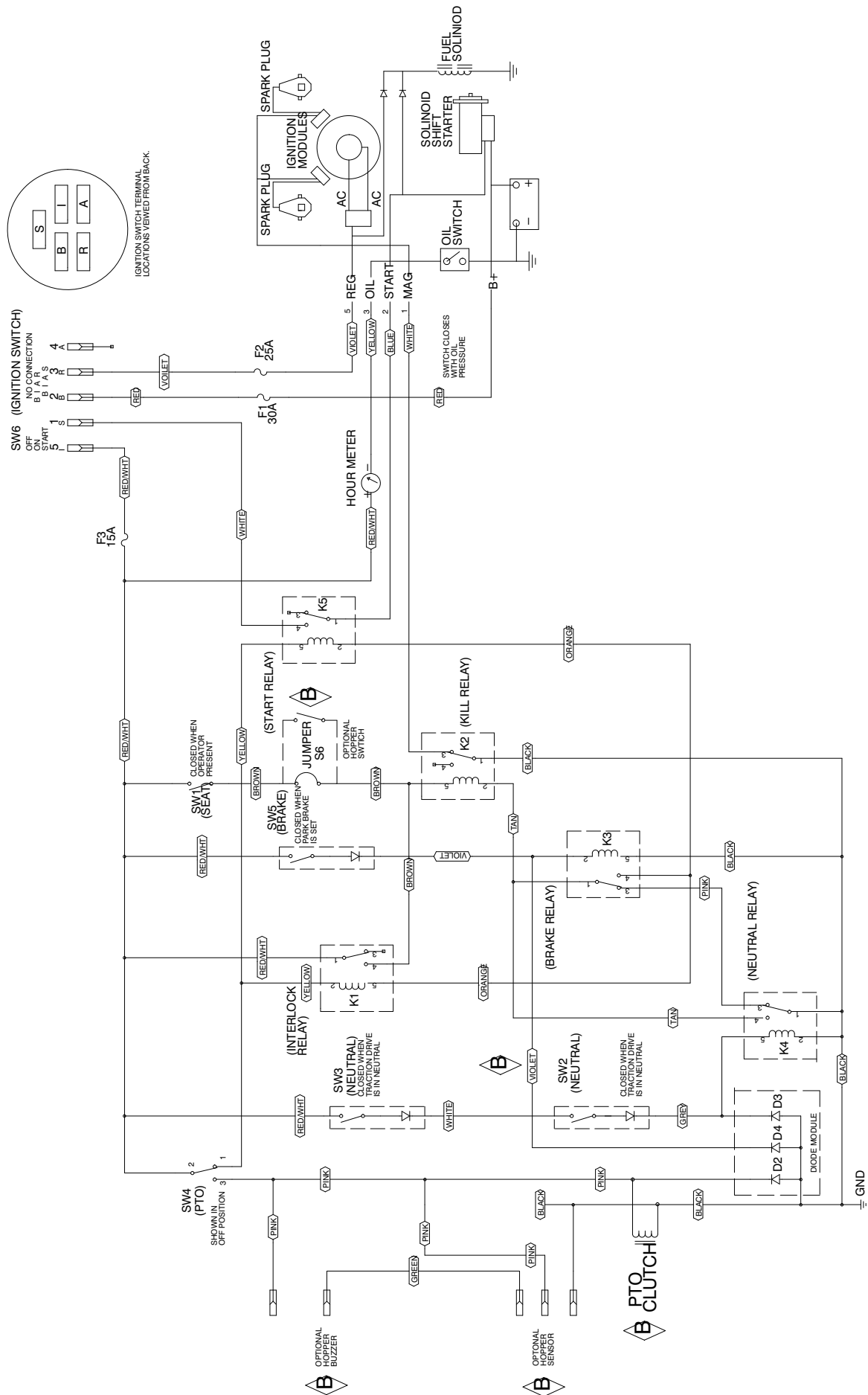

Hydraulic Schematic

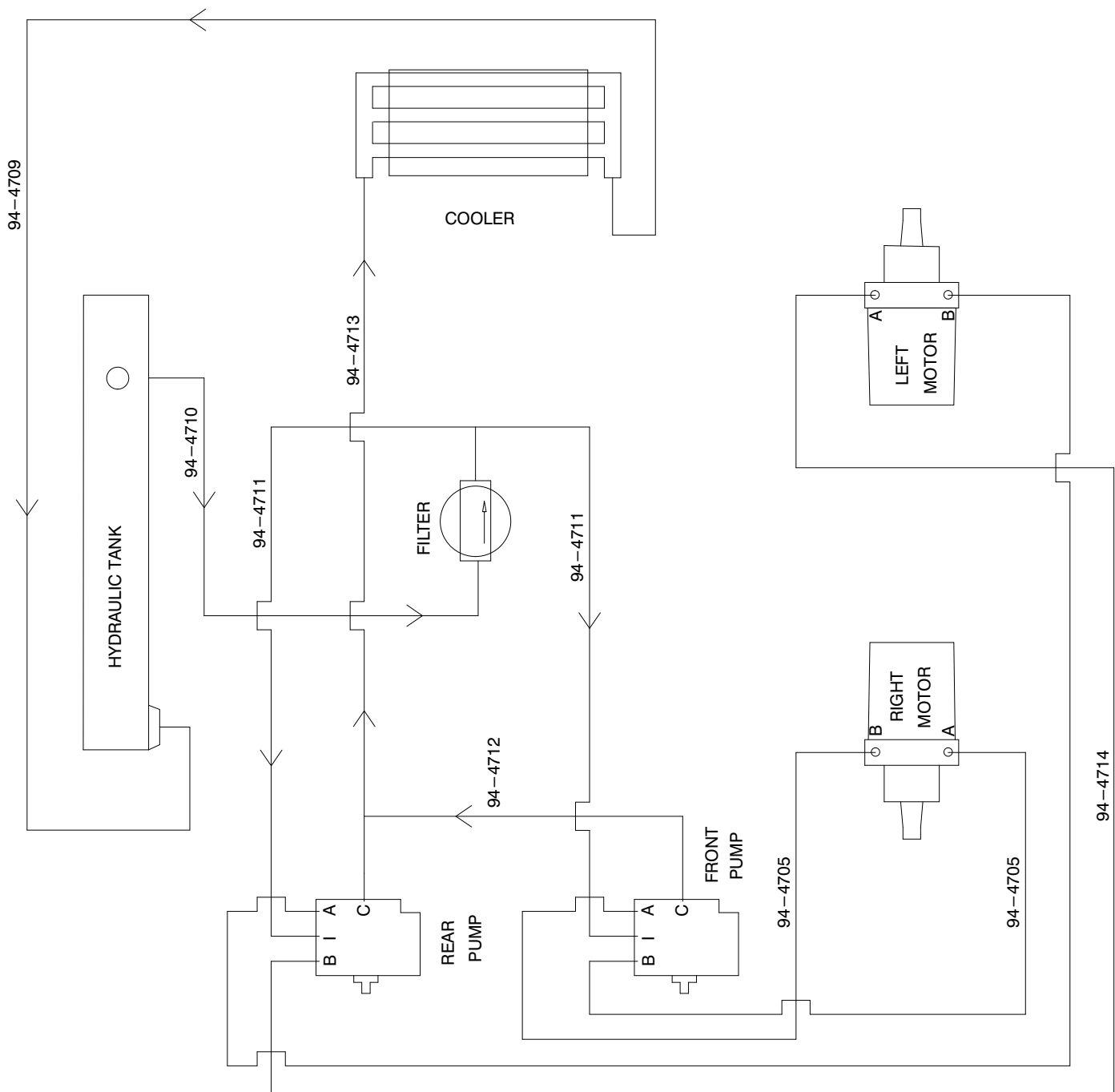

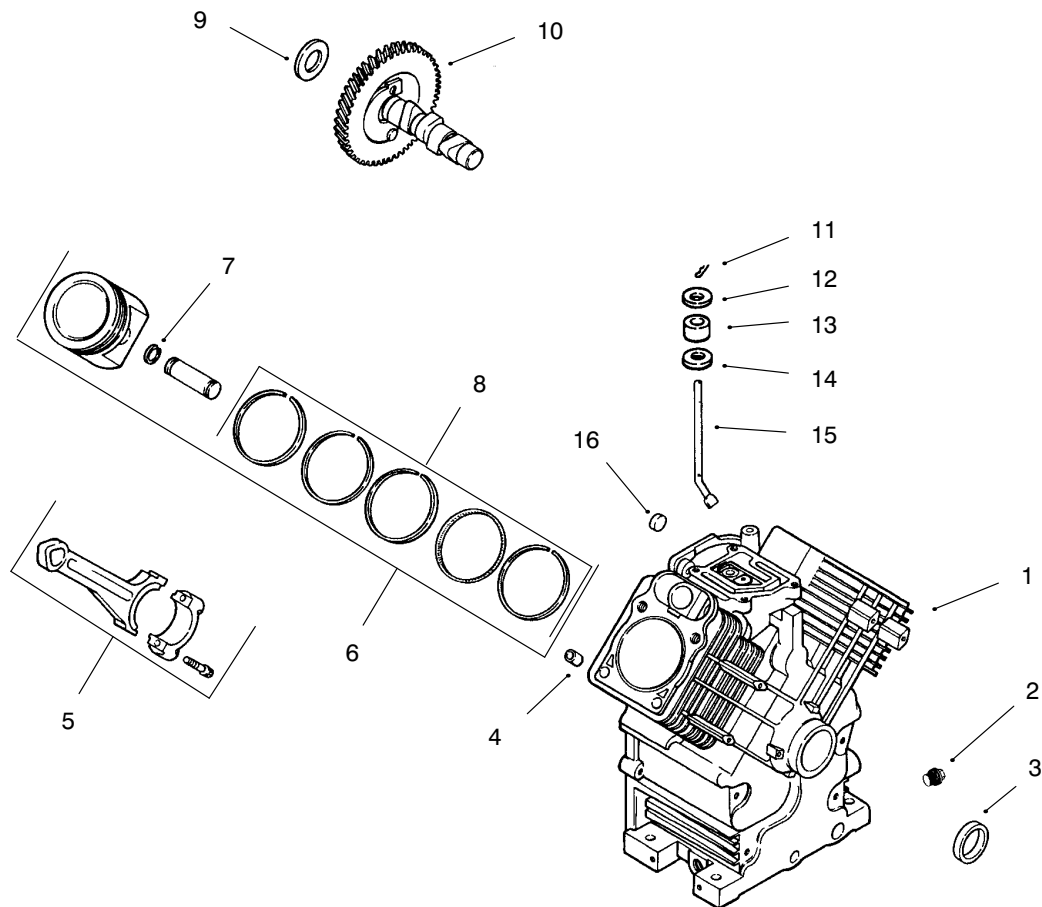

Crankcase

Ref. No.	Description	Part No.	Ref. No.	Description	Part No.
1	Kit, service crankcase (Incl. 4,16,X-75-10 (2))	24 561 33			
2.	Plug, pipe 3/8 (2)	X-75-2			
3.	Seal, oil front	24 032 01			
4.	Pin, dowel locating (6)	12 380 17			
5.	Connecting Rod (Std.) (2)	24 067 09			
	Connecting Rod (.25) (2)	24 067 10			
6.	Piston w/Ring Set (Std.) (2) (Includes 7,8)	24 874 06			
7.	Retainer, piston pin (4)	24 018 01			
8.	Ring Set (Std.)	24 108 04			
9.	Shim, camshaft (A.R.) red	12 422 09			
	Shim, camshaft (A.R.) black	12 422 13			
	Shim, camshaft (A.R.) white	12 422 07			
	Shim, camshaft (A.R.) blue	12 422 08			
	Shim, camshaft - yellow	12 422 10			
	Shim, camshaft (A.R.) green	12 422 11			
	Shim, camshaft (A.R.) gray	12 422 12			
10.	Camshaft	24 012 05			
11.	Pin, hitch	12 380 04			
12.	Washer, plain 6 mm	M-0631005			
13.	Seal, governor cross shaft	12 032 01			
14.	Washer, plain 1/4	X-25-102			
15.	Shaft, governor cross	24 144 01			
16.	Plug, cup	52 139 09			

Kohler Engine CH25S 68576
Obtain Parts from Kohler

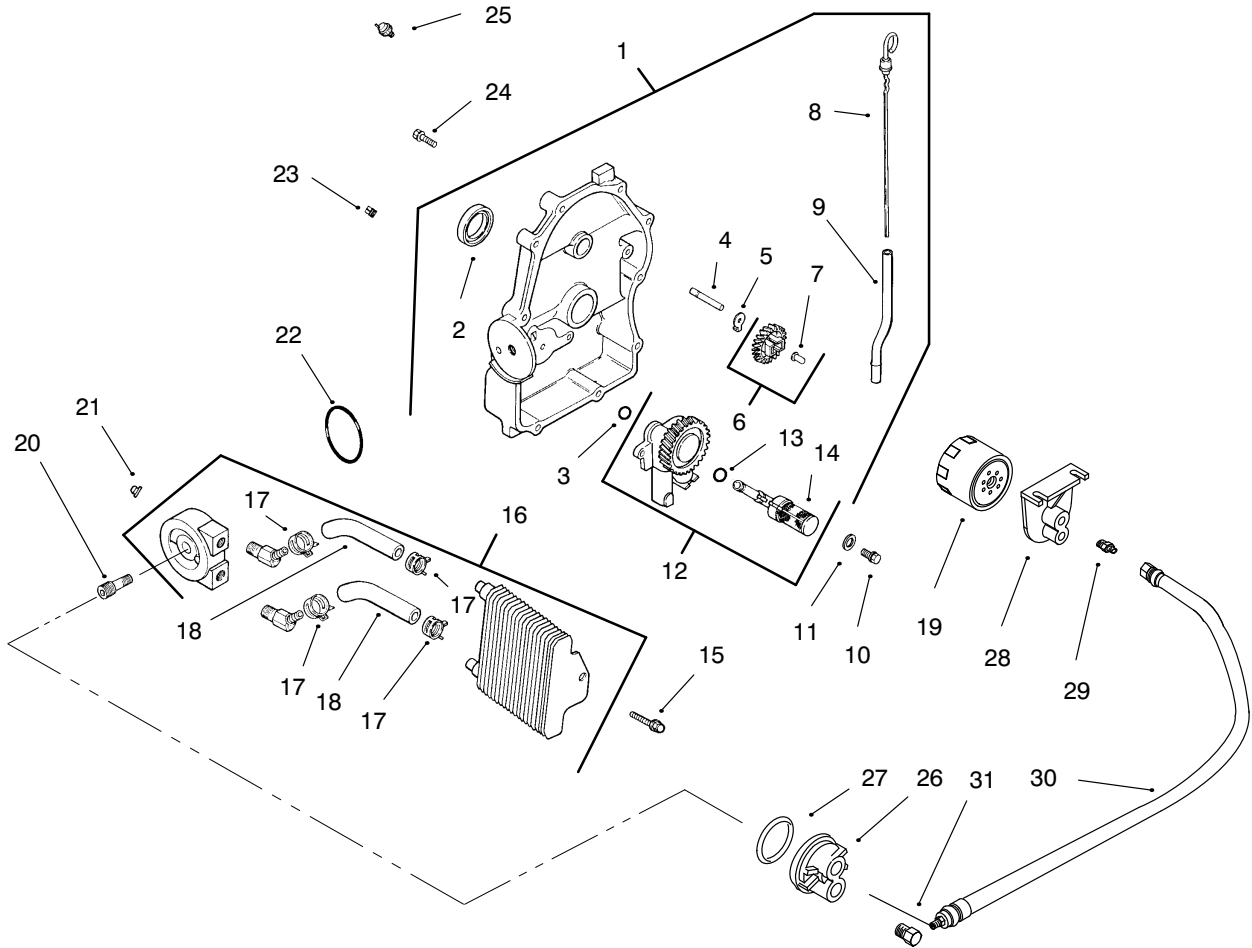

Oil Pan / Lubrication

Ref. No.	Description	Part No.
2.	Seal, oil (PTO end)	52 032 08
3.	O-Ring	24 153 08
4.	Shaft, governor gear	12 144 02
5.	Tab, locking	52 448 02
6.	Kit, governor gear w/pin (Includes 7)	24 043 12
7.	Pin, governor regulating	12 380 01
8.	Dipstick	24 038 03
9.	Tube, dipstick	24 124 04
10.	Screw, hex. flange M6x1.0x25 (2)	M-0645025
11.	Washer, plain 6 mm (2)	M-0631005
12.	Oil pump assembly (Includes 13-14)	24 393 10
13.	O-Ring, oil pick-up	24 153 01
14.	Pick-up, oil	24 381 04
15.	Screw, hex. cap M6x1.7x18 (2)	24 086 12
16.	Cooler, oil (Includes 17,18)	24 594 09
17.	Clamp, oil cooler (4)	24 237 03
18.	Hose, oil (2)	24 326 15
19.	Filter, oil	52 050 02
20.	Nipple, oil filter	24 136 03
21.	Nut, plastic (2)	24 100 01
22.	O-Ring	24 153 13
23.	Plug, allen hd. 1/8 pipe	X-75-23

Ref. No.	Description	Part No.
24.	Screw, hex. flange M8x1.25x45 (10)	24 086 16
25.	Switch, oil pressure NOT ILLUSTRATED	24 099 03
	Decal, oil sentry	25 113 05
	Decal, oil cooler	24 113 25
26.	Adapter - Oil Filter	24 029 02
27.	O-Ring	24 153 13
28.	Adapter - Remote Filter	25 029 01
29.	Nipple (2)	52 136 02
30.	Hose - Oil (2)	52 326 11
31.	Fitting (2)	24 294 04

Kohler Engine CH25S 68576
Obtain Parts from Kohler

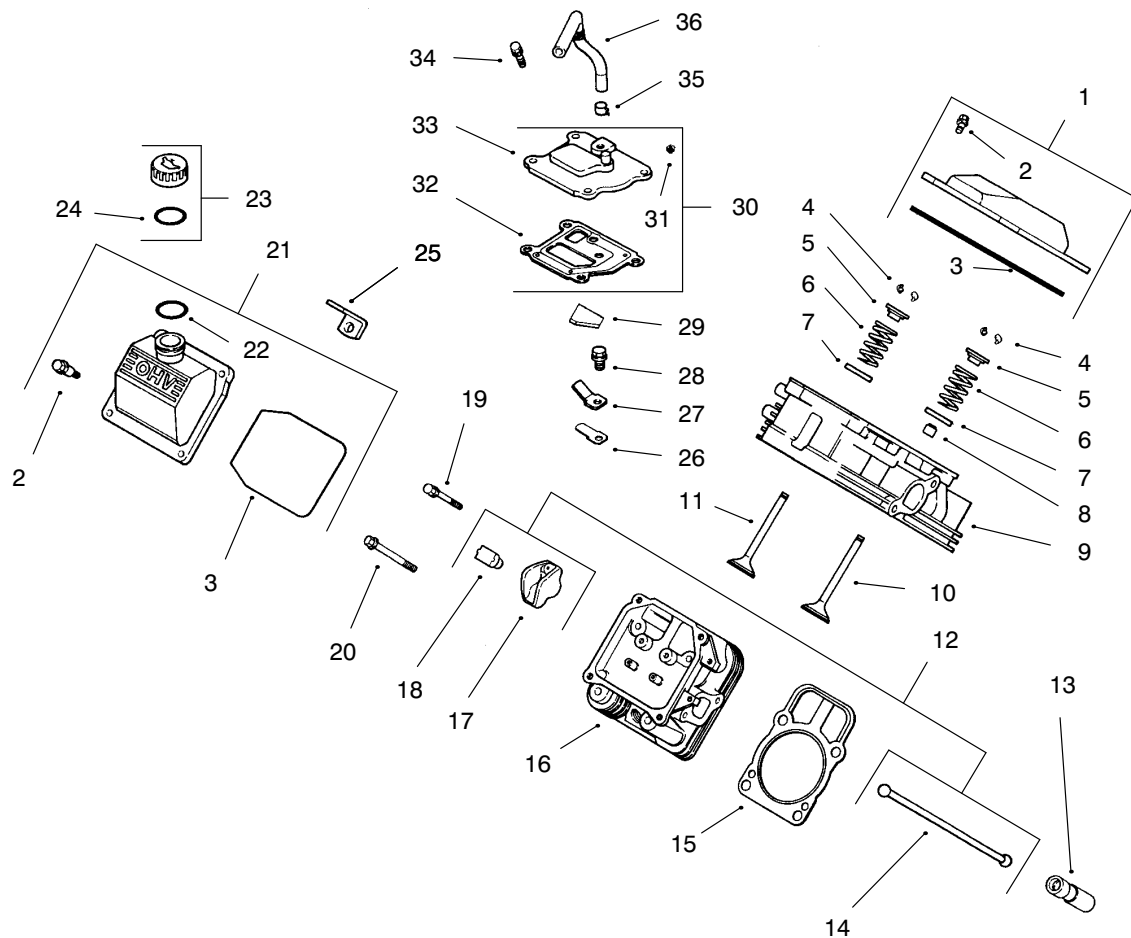

Head / Valve / Breather

Ref. No.	Description	Part No.	Ref. No.	Description	Part No.
1.	Kit, valve cover – plain (Includes 2,3)	24 755 74	21.	Kit, valve cover – oil fill (Includes 2,3,22)	24 755 75
2.	Screw, shoulder (4)	24 086 32	22.	O-Ring	24 153 09
3.	O-Ring	24 153 16	23.	Kit, oil fill cap (Includes 24)	12 173 04
4.	Kit, retainer (4)	12 755 03	24.	O-Ring, oil fill cap	12 153 03
5.	Cap, valve spring (4)	12 173 01	25.	Strap, lifting	24 445 01
6.	Spring, valve (4)	24 089 02	26.	Reed, breather	24 402 03
7.	Retainer, spring (4)	235011	27.	Retainer, breather reed	12 018 01
8.	Seal, valve stem (2)	24 032 05	28.	Screw, hex. flange M5x0.8x10	M-0545010
9.	Head assembly, #1 cylinder	24 318 13	29.	Filter, breather	24 050 01
10.	Valve, intake (Std.) (2)	24 017 01	30.	Kit, breather (Includes 31-33)	24 033 01
	Valve, intake (.25) (2)	24 017 02	31.	Plug, allen head 1/8 pipe	X-75-23
11.	Valve, exhaust (Std.) (2)	24 016 01	32.	Gasket, breather	24 041 23
	Valve, exhaust (.25) (2)	24 016 02	33.	Cover, breather	24 096 02
12.	Kit, valve train (Includes 14,17,18)	24 755 66	34.	Screw, hex. flange M6x1.0x20 (4)	M-0645020
13.	Lifter, valve (4)	12 351 02	35.	Clamp, breather	X-426-9
14.	Rod, push (4)	24 411 05	36.	Hose, breather	24 326 06
15.	Gasket, cylinder head (2)	24 041 16			
16.	Head assembly, #2 cylinder	24 318 14			
17.	Arm, rocker (4)	25 186 01			
18.	Pivot, rocker arm (4)	24 599 01			
19.	Screw, hex. flange M6x1.0x34 (4)	M-0640034			
20.	Screw, hex. flange M10x1.5x90 (8)	12 086 16			

Kohler Engine CH25S 68576
Obtain Parts from Kohler

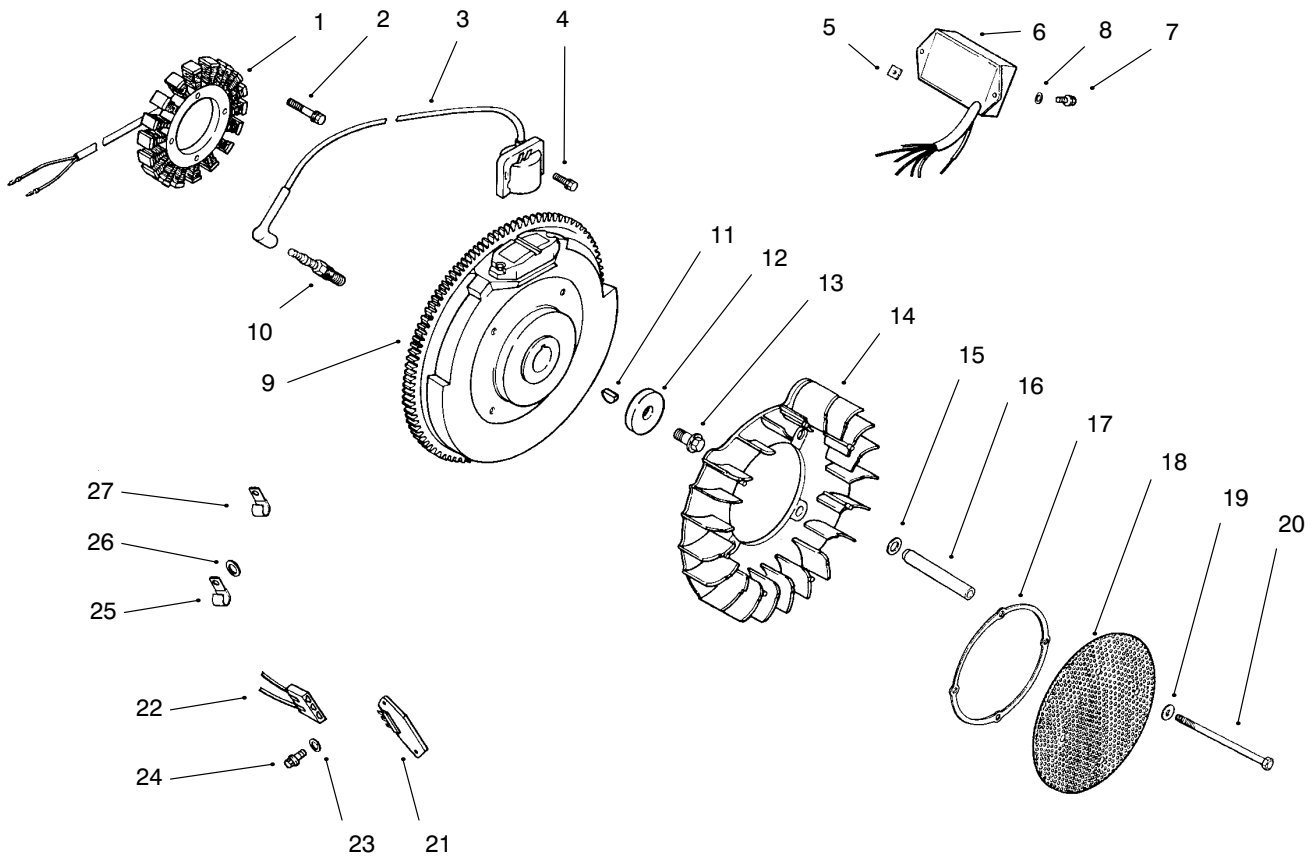

Ignition / Electrical

Ref. No.	Description	Part No.
1.	Stator – 15 amp	24 085 03
2.	Screw, hex. cap M5x0.8x25 (2)	M-0548025
3.	Module, ignition	24 162 25
4.	Screw, hex. socket hd. M5x0.8x25 (4)	M-0561025
5.	Nut, plastic (2)	24 100 02
6.	Module, speed advance	24 584 09
7.	Screw, pan head M4.2x13 (2)	M-0461013
8.	Washer, lock 1/4"	X-22-11
9.	Flywheel	24 025 03
10.	Spark Plug (2)	12 132 06
11.	Key	X-42-15
12.	Washer, plain 3/8.	12 468 03
13.	Screw, hex. flange M10x1.5x46	12 086 14
14.	Fan	24 157 03
15.	Washer, spring 10 mm (4)	24 468 11
16.	Spacer, grass screen (4)	24 112 14
17.	Ring, support	24 141 06
18.	Screen, grass	24 162 25

Ref. No.	Description	Part No.
19.	Washer, plain (4)	X-25-53
20.	Screw, hex. head. M6x1.0x100 (4)	M-0603100
21.	Rectifier-regulator 15 amp	25 403 03
22.	Connector	236602
23.	Washer, plain 3/16 (2)	X-25-92
24.	Screw, phillips hd. 11-16x7/8 (2)	24 086 18
25.	Clip, cable	47 154 01
26.	Washer, plain 1/4	X-25-63
27.	Clip, cable	48 154 02
	NOT ILLUSTRATED	
	Bracket, stator wire	24 126 71
	Harness, wiring	24 176 16
	Lead, black (4" – 18 gauge – insulated grip barrel eyelet terminals)	25 518 28
	Screw, set (adjusts grass scraper blade)	25 086 43
	Washer, plain 1/4" (for ground screw & wire)	X-25-63

Kohler Engine CH25S 68576
Obtain Parts from Kohler

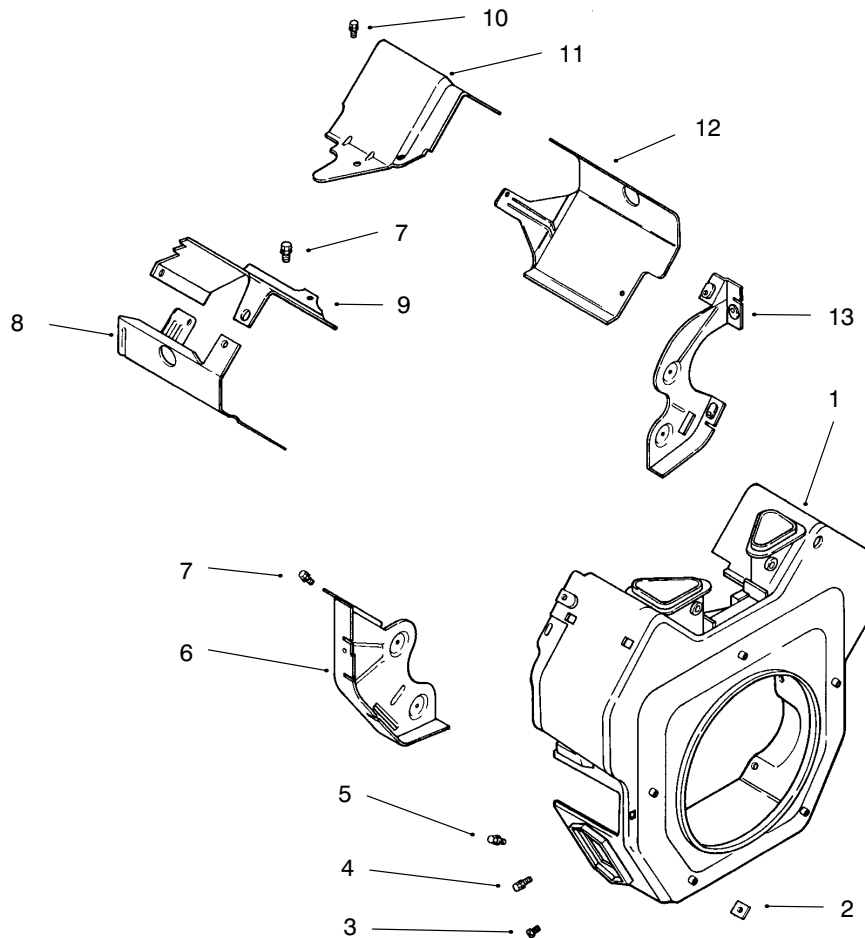

Blower Housing & Baffles

Ref. No.	Description	Part No.	Ref. No.	Description	Part No.
1.	Housing, blower	54 027 05			
2.	Nut, plastic (2)	24 100 01			
3.	Screw, hex. flange M5x0.8x16	M-0551016			
4.	Screw, hex flange M5x0.8x16 (4)	M-0545016			
5.	Screw, hex flange M5x0.8x20 (2)	M-0545020			
6.	Plate, backing - #2 side	24 146 11			
7.	Screw, hex. flange M6x1.0x16 (6)	M-0645016			
8.	Baffle, cylinder barrel - #2 side	24 063 28			
9.	Baffle, valley - #2 side	24 063 17			
10.	Screw, hex. flange M5x0.8x10 (2)	M-0545010			
11.	Baffle, valley - #1 side	24 063 24			
12.	Baffle, cylinder barrel - #1 side	24 063 30			
13.	Plate, backing - #1 side NOT ILLUSTRATED	24 146 08			
	Decal, horsepower	24 113 09			

Kohler Engine CH25S 68576
Obtain Parts from Kohler

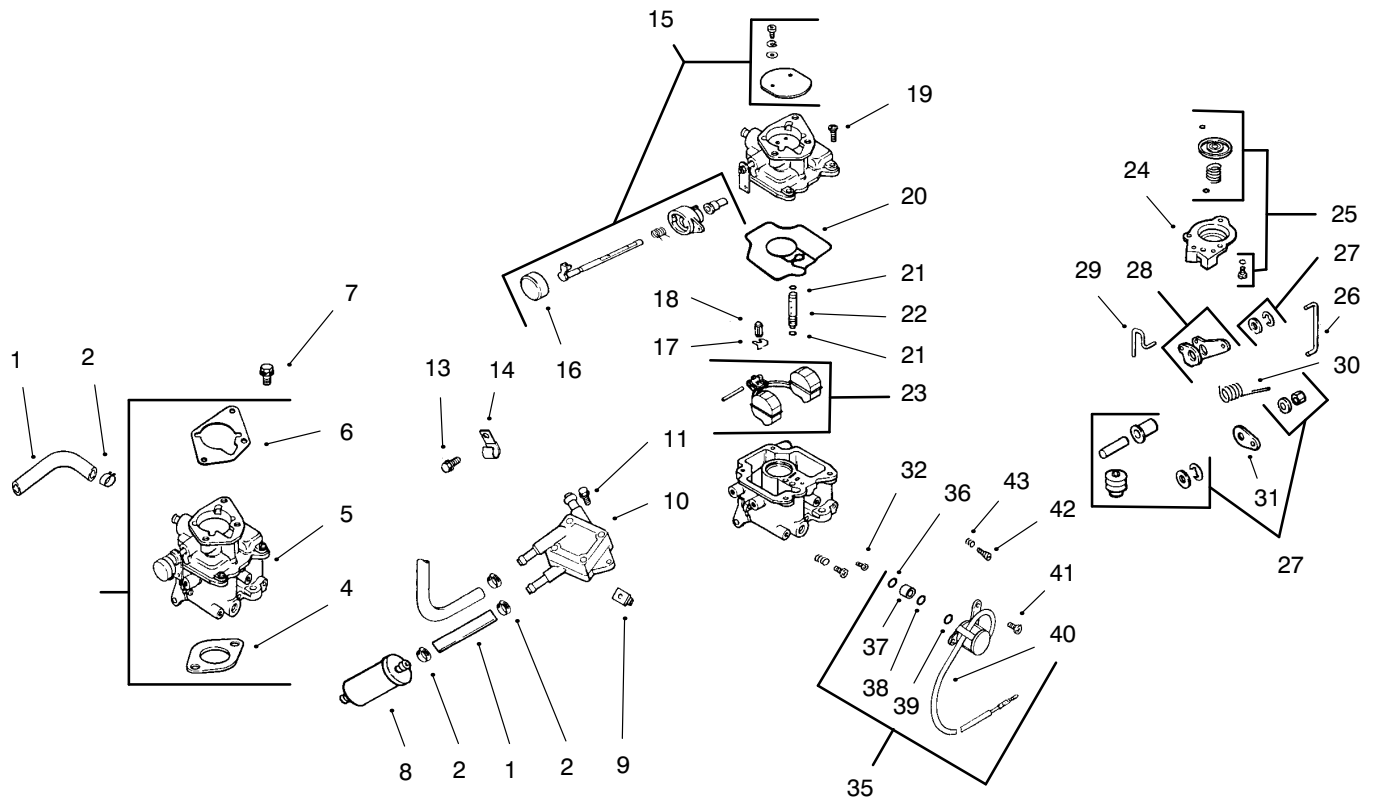

Fuel System

Ref. No.	Description	Part No.	Ref. No.	Description	Part No.
1.	Line, fuel 9" (2)	25 353 10	24.	Housing, pump	24 081 05
2.	Clamp, hose (6)	X-426-9	25.	Kit, repair – accelerator pump seal & bushing)	24 757 08
3.	Kit, carburetor w/gasket (Includes 4-6)	24 853 34	26.	Linkage, rod	24 079 07
4.	Gasket, air cleaner	24 041 06	27.	Kit, repair – accelerator pump diaphragm	24 757 09
5.	Carburetor assembly (Includes 15-43 and carburetor repair kit (For information only not available separately)	24 757 03)	28.	Lever, linkage	24 090 16
6.	Gasket, carburetor	24 053 34	29.	Linkage, rod	24 079 06
7.	Screw, hex. flange M6x1.0x30 (2)	24 041 17	30.	Spring, linkage	24 089 27
8.	Filter, fuel	M-0651030	31.	Lever, linkage	24 090 15
9.	Nut, plastic	24 050 02	32.	Jet, main	24 337 30
10.	Pump, fuel – pulse	24 100 01	33.	Spring, idle adjust	24 089 11
11.	Screw, hex. cap 18 mm (2)	24 393 04	34.	Needle, idle adjust	24 368 01
12.	Line, fuel 15-1/2"	24 086 12	35.	Kit, solenoid assembly (Includes 36-41)	24 757 01
13.	Screw, hex. flange M6x1.0x10	24 353 02	36.	O-Ring, solenoid	24 153 06
14.	Clip, cable	M-0650012	37.	Seat, solenoid	24 521 01
15.	Kit, choke repair (Includes 16)	24 154 03	38.	O-Ring, solenoid	24 153 05
16.	Cap, choke lever	24 757 07	39.	O-Ring, solenoid	24 153 04
17.	Clip, inlet needle valve	24 173 02	40.	Solenoid	24 435 01
18.	Valve, inlet needle	24 154 01	41.	Screw, solenoid (2)	24 086 07
19.	Screw, carburetor body (4)	24 462 01	42.	Screw, idle speed adjust	24 086 10
20.	Gasket, carburetor body	24 086 09	43.	Spring, idle speed adjust	24 089 10
21.	O-Ring, slow jet (2)	24 041 09		NOT ILLUSTRATE	
22.	Jet, slow	24 153 02		Kit, carburetor repair	24 757 03
23.	Kit, float repair	24 337 29			
		24 757 02			

Kohler Engine CH25S 68576
Obtain Parts from Kohler

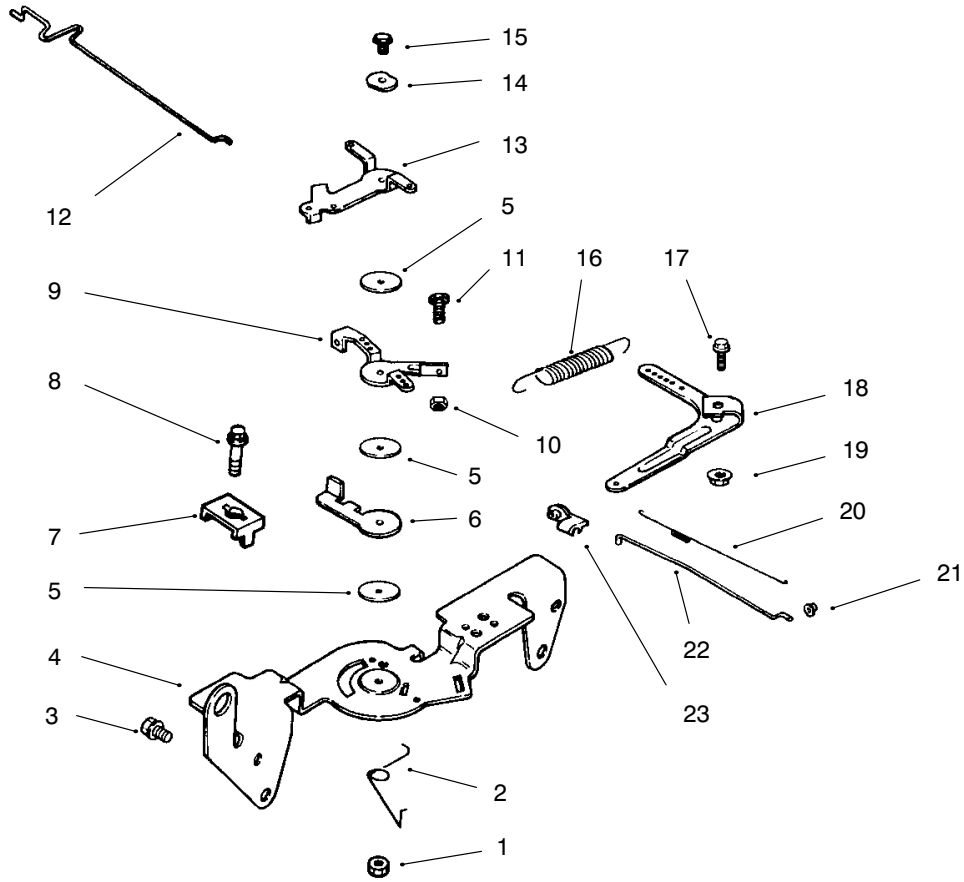

Engine Controls

Ref. No.	Description	Part No.
1.	Nut, hex. lock M5x0.8	M-0547050
2.	Spring, choke return	24 089 03
3.	Screw, hex. flange M6x1.0x16 (4)	M-0645016
4.	Bracket, control	24 126 56
5.	Washer, plain 1/4 (3)	24 468 01
6.	Lever, throttle actuator	24 090 07
7.	Clamp, cable (2)	12 237 01
8.	Screw hex. flange M5x0.8x16 (3)	M-0545016
9.	Lever, throttle control	24 090 03
10.	Nut, hex. flange M4x0.7	M-0446030
11.	Screw, hex. flange M4x0.7x30	M-0401030
12.	Linkage, choke	24 079 02
13.	Lever, choke	24 090 05
14.	Washer, spring 1/4	41 468 03
15.	Screw, hex. flange M5x0.8x20	M-0545020
16.	Spring, governor	24 089 18
17.	Screw, hex. flange M6x1.0x25	SM-0642025
18.	Lever, governor	24 090 14
19.	Nut, hex. flange M6x1.0	M-0641060
20.	Spring, linkage	24 089 01
21.	Bushing, linkage retaining	25 158 08

Ref. No.	Description	Part No.
22.	Linkage, throttle	24 079 01
23.	Bushing, throttle linkage	25 158 11

Kohler Engine CH25S 68576
Obtain Parts from Kohler

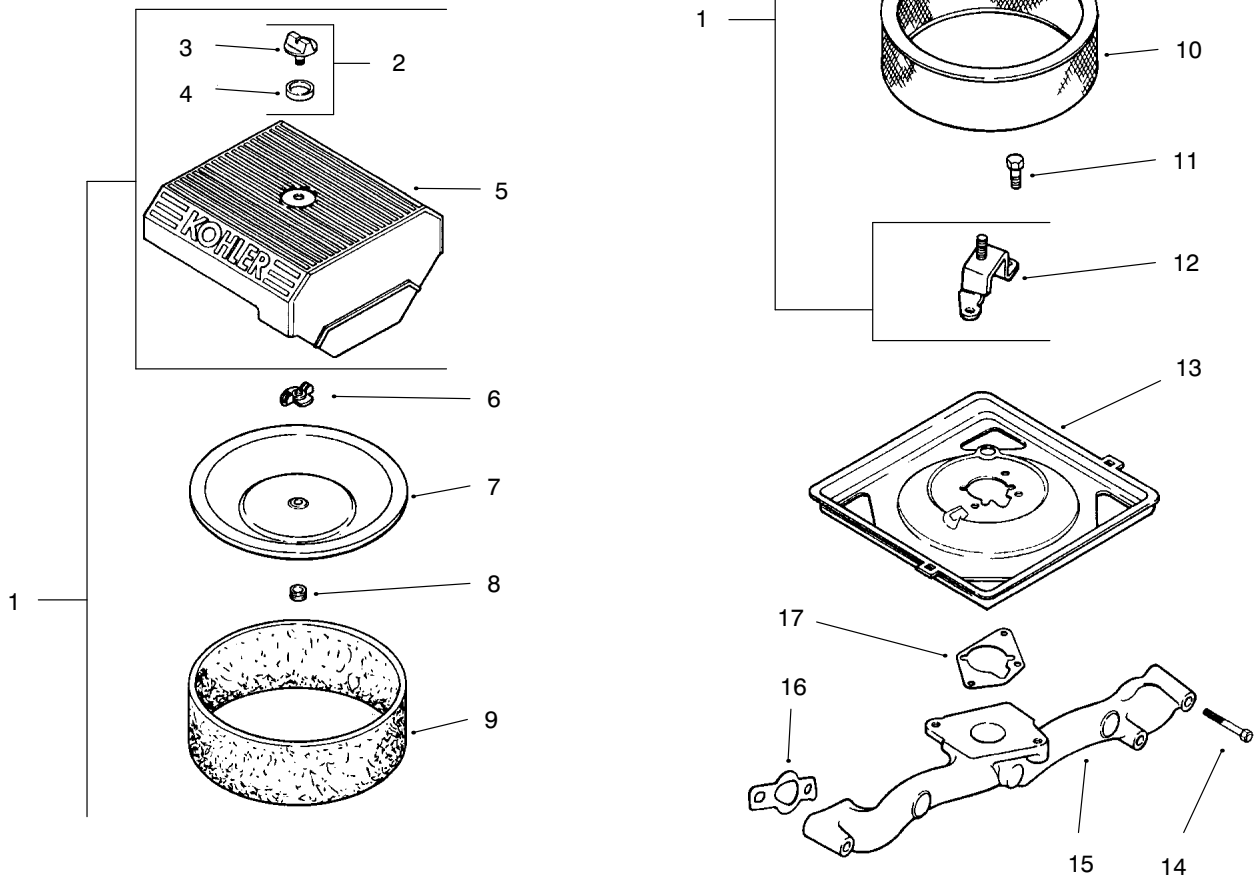

Air Intake

Ref. No.	Description	Part No.	Ref. No.	Description	Part No.
1.	Kit, air cleaner cover (Includes 2-5,12)	24 743 05			
2.	Kit, knob w/seal (Includes 3,4)	54 755 01			
3.	Knob, cover	25 341 03			
4.	O-Ring	24 153 15			
5.	Cover, air cleaner	24 096 24			
6.	Wing Nut	12 100 01			
7.	Cover, inner air cleaner	24 096 01			
8.	Seal, air intake	230046			
9.	Precleaner, element	24 083 05			
10.	Element, air cleaner	24 083 03			
11.	Screw, hex. flange M6x1.0x16 (3)	M-0645016			
12.	Bracket, air cleaner base (40mm stud CH25)	24 126 43			
13.	Base, air cleaner	24 094 11			
14.	Screw, hex. flange M6x1.0x55 (4)	M-0651055			
15.	Manifold, intake	24 164 14			
16.	Gasket, intake manifold (2)	24 041 01			
17.	Gasket, air cleaner base	24 041 06			

Kohler Engine CH25S 68576
Obtain Parts from Kohler

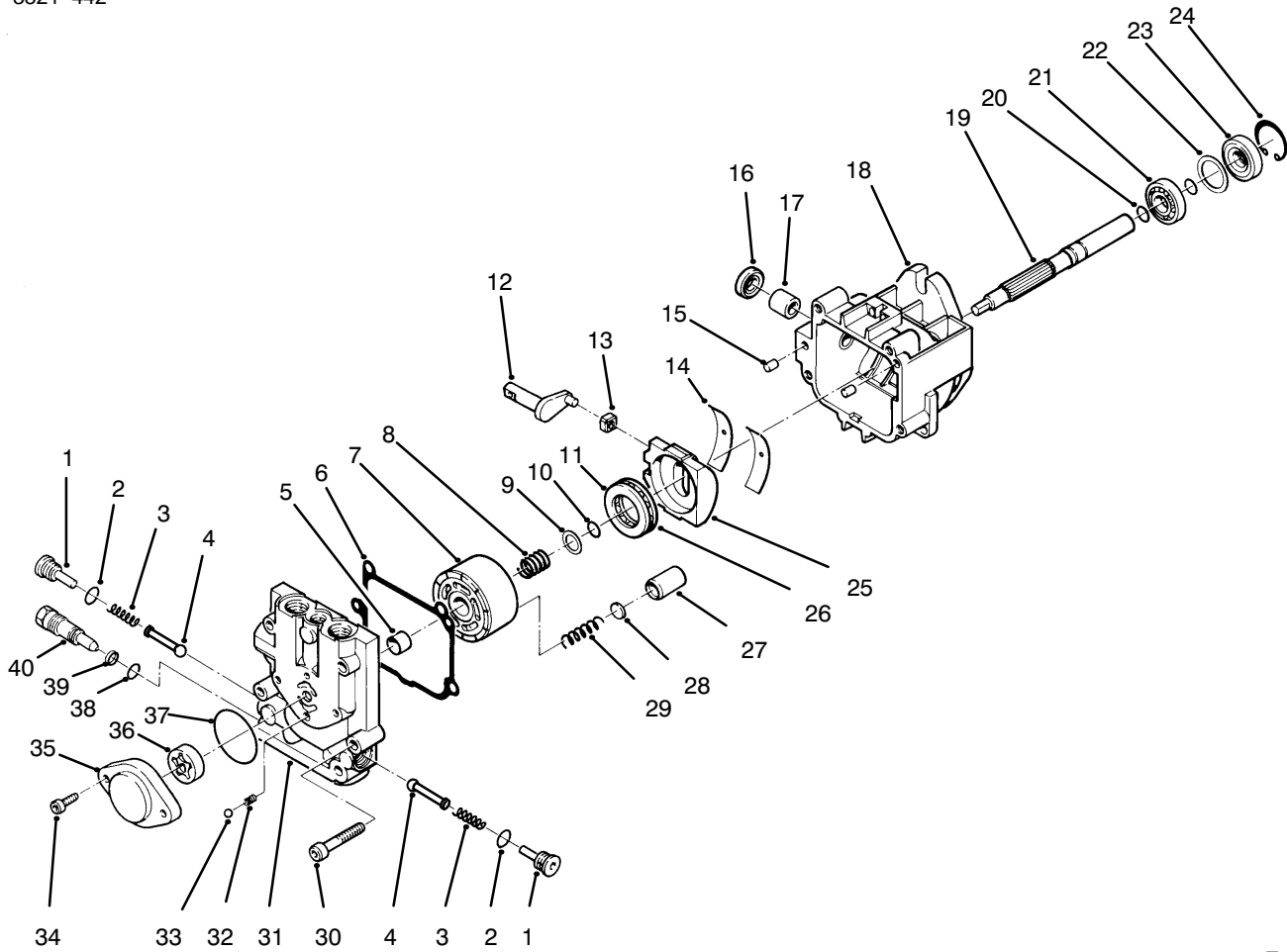

T-1236

Hydraulic Pump Assembly No. 98-4374 and 98-4375

Ref. No.	Part No.	Qty.	Description
1	80-6120	1	Check Valve Kit (Incl. Ref. #2-4)
2		2	Seal - O-Ring
3		2	Spring
4		2	Poppet
5		1	Journal - Bearing
6		1	Gasket - End Cap
7		1	Cylinder Block Kit (Incl. Ref. #8-10 & 27-29)
8		1	Spring
9		1	Washer
10		1	Ring - Retaining
11		1	Plate - Thrust
12		1	Arm - Trunnion
13		1	Guide - Slot
14		2	Cradle - Bearing
15		2	Pin
16		1	Seal - Lip
17		1	Journal - Bearing
18		1	Housing - Assembly (Incl. Ref. #16 & 17)
19		1	Shaft
20		2	Ring - Retaining
21		1	Bearing - Ball
22		1	Spacer

Ref. No.	Part No.	Qty.	Description
23		1	Seal - Lip
24		1	Ring - Retaining
25		1	Swashplate Assembly
26		1	Roller - Thrust
27		5	Piston
28		5	Washer - Thrust
29		5	Spring - Piston
30		4	Screw
31		1	End Cap Assembly (Incl. Ref. #5)
32		1	Ball
33		1	Spring
34		2	Screw
35		1	Housing - Charge Pump
36		1	Gerotor Assembly
37		1	Seal - O-Ring
38		1	Seal - O-Ring
39		1	Ring - Back-Up
40		1	Valve - Bypass
*	80-6110	1	Charge Relief Valve Kit (Incl. Ref. #32-33)
*	80-6130	1	Overhaul Seal Kit (Incl. Ref. #6, 10, 16, 20, 23 & 37-39)

*Not Illustrated

Toro Part Number Index

Part No.	Page No.	Ref. No.	Qty.	Description
2844	10	25	1	Washer-Flat
8830	1	34	1	Retainer-"j"
101884	3	2:1	2	Nut-Hex
102950	3	3:2	1	Washer
105805	3	3:1	1	Nut
106948	3	19	1	Tray-Battery
106950	4	23	2	Bushing
111216	3	2	1	Switch-Ignition
113010	3	12	1	Hold Down
113050	3	5	1	Cover-Switch
113179	3	3:3	1	Nut
113697	9	27	2	Eye Bolt
114511	11	29	1	Spacer
116397	3	32	5	Relay
9201604	3	2:2	1	Washer-Lock
9202204	11	11	1	Washer
9202574	4	35	A/R	Washer-Flat
9202574	9	5	A/R	Washer-Flat
5-0698	11	13	1	Key
10-6850	4	14	2	Drum Brake
10-6870	4	15	2	Hub-Wheel
12-5450	10	3	2	Screw-Thread Forming
24-0760	2	10	1	Exchanger-Heat
26-3790	4	16	2	Nut-Lock
27-2320	9	16	2	Bearing
27-6230	11	1	1	Bolt-Wheel
28-3893	3	17	1	ASM-Wire
28-8080	3	14	1	Boot-Terminal (Red)
42-9430	10	8	1	Bolt w/Washer
42-9850	10	27	2	Washer-Lock
48-8020	10	9	1	Washer-Lock
52-2480	7	41	2	Spacer
52-5260	1	35	2	Rubber Pad
62-7650	2	19	1	Gasket
62-7770	3	36	2	Key-Ignition
63-8410	7	16	2	Washer-Flat
66-0120	2	3	1	Knob
66-4210	11	26	1	Pulley-Idler
67-7490	11	41	1	Key
67-8110	5	9	1	Filter-Oil
70-9840	4	17:5	4	Brake Shoe
70-9850	4	17:3	2	Clip-Retainer
70-9860	4	17:2	2	Cam Shaft
70-9870	4	17:1	2	Plate-Backing
70-9880	4	17:4	4	Spring-Return
71-1500	4	17	2	Brake ASM
74-0720	7	21	1	Tube-Manual
76-0800	6	45	2	Seal Kit-Wheel Motor
78-0020	3	4	1	Hourmeter
78-3320	3	4:1	1	Clamp-Hour Meter
80-6090	11	37	2	Key-Square
80-8170	11	36	2	Pulley-Pump
84-2000	4	20	2	Bracket-Brake
85-6540	4	13	8	Stud
86-9080	5	11	1	Head-Filter
88-6460	11	25	1	Spring - Extension
92-1705	5	28	1	Screen-Filter
92-6280	7	9	1	Seat ASM
92-6282	7	9:4	1	Seat-Switch
92-6287	3	11	1	Wire-Ground
92-6533	7	9:2	1	Kit-Replacement Cushion

*Not Illustrated

Toro Part Number Index (cont.)

Part No.	Page No.	Ref. No.	Qty.	Description
92-6534	7	9:1	1	Shell-Seat
92-6780	10	14	4	Nut-HHF
92-9811	3	3	1	Switch-Toggle
93-0307	1	12	1	Nut-Lock
93-0350	10	12	2	Gasket-Exhaust
93-1622	11	15	2	Pulley-Idler
93-3101	2	20	1	Gas Cap
93-4365	5	27	1	Oil Cap
93-5107	2	9	2	Fitting-Adapter
93-7340	7	10	1	Decal-Toro
93-9198	1	24	1	Decal-Warning
93-9198	8	49	1	Decal-Warning
94-4602	4	2	1	Lever-Brake
94-4607	11	18	1	Belt-Pump Drive
94-4608	11	19	1	Belt-PTO
94-4618-03	1	1	1	Support-Engine
94-4628	11	14	1	Engine-Pulley
94-4629	11	32	1	Clutch-Pulley
94-4632	11	20	1	Clutch ASM
94-4635-01	7	45	1	Plate-Console Support
94-4640	6	41	2	Motor-Hyd Wheel
94-4641	11	34	1	Gearbox-PTO Drive
94-4642-03	5	23	1	Strap-Hydraulic Tank
94-4647-01	1	17	1	Castor Fork
94-4658-03	11	6	1	Pump-Mount
94-4665	1	11	1	Dustcap
94-4672-03	7	13	1	Latch
94-4678	5	4	2	Arm-Pump Control
94-4685	11	27	1	Spacer-Idler
94-4688	11	12	1	Spacer-Engine Shaft
94-4689	11	16	1	Spacer-Engine Shaft
94-4696	3	31	1	Angle-Mount
94-4698	7	1	1	Console
94-4699	7	15	1	Box-Utility
94-4700	5	29	1	Tank-Hydraulic
94-4701-03	5	5	1	Plate-Control
94-4702-03	5	7	1	Plate-Control
94-4705	5	38	2	Hose ASM
94-4709	5	21	1	Hose ASM-Hyd
94-4710	5	14	1	Hose ASM-Hyd
94-4712	5	8	1	Hose ASM-Hyd
94-4713	5	19	1	Hose ASM-Hyd
94-4714	5	2	2	Hose ASM-Hyd
94-4717	9	9	1	Rod-Control
94-4718	9	13	1	Rod-Control
94-4721-03	7	20	1	Hinge
94-4722	11	42	1	Shaft-Drive
94-4753	1	22	1	Tube-Spacer
94-4755	1	32	2	Pivot Pin ASM
94-4787-03	11	39	1	Mount-Plate
94-4792	11	5	1	Spacer-Idler Arm
94-4797-03	3	23	1	Channel-Mount Switch
94-4798-01	7	30	1	Plate-Tank Support
94-4799-03	7	26	1	Strap-Fuel Tank
94-6146	3	18	2	Retainer-Battery
94-6666	3	13	1	ASM-Battery/Decal
94-9384	1	23:1	1	Tire
94-9385	1	26:3	2	Wheel
94-9388	1	26:1	2	Tire
94-9460	3	25	1	Plate-Switch Mount
94-9488-03	7	8	1	Strap-Console
94-9489-01	1	6	1	Housing-Spindle

*Not Illustrated

Toro Part Number Index (cont.)

Part No.	Page No.	Ref. No.	Qty.	Description
94-9490	9	3	2	Grip-Cushion
94-9491-01	7	34	1	Plate-Cover
94-9494	10	13	1	Manifold
94-9495	10	15	1	Muffler
94-9496	7	18	1	Pin-Pivot
94-9499	2	24	1	Tube-Oil Drain
94-9515	9	17	1	Shaft-Control
94-9517-03	9	2	1	Handle-Control LH
94-9524	9	1	1	Spacer-Control
94-9525-03	5	15	1	Angle-Mount
94-9529-01	7	40	1	Plate-Seat
94-9551	9	7	1	Handle-Control RH
94-9552	9	6	2	Center Control ASM
94-9553	2	21	1	Fuel Tank ASM
94-9556-03	2	5	1	Cooler Shroud ASM
94-9561-03	10	11	1	Bracket-Manifold Shield
94-9573-01	4	26	2	Mount-Lever
94-9580	3	6	2	Clamp-J
94-9591-03	9	32	1	Mount-Channel
94-9593	9	34	2	Spacer-Damper
94-9594-03	9	19	1	Hub-Control
94-9597-03	2	18	1	Cover-Fuel Tank Opening
94-9598	1	3	1	Frame ASM
94-9599	11	4	1	Spring-Extension
95-1950	11	3	1	Arm ASM
95-1957	1	31	1	Decal-Z325
95-1962	7	2	6	Clip
95-1967	11	28	1	Spacer-Spring
95-1968	11	30	1	Idler Arm ASM
98-0976	2	26	1	Hose-Fuel
98-1301-03	11	23	1	Stop-Clutch
98-1306	7	14	1	Decal-No Riders
98-1313	8	46	1	Decal-Operation
98-1319	2	22	1	Foam-Tank
98-1322	9	31	2	Spring-Extension
98-1324	3	30	3	Switch-Interrupter
98-1326	10	24	1	Baffle-Heat
98-1329	10	17	1	Baffle-Heat
98-1349	10	28	1	Baffle-Heat
98-1956	2	32	1	Control-Push Pull
98-1967	10	1	1	Top Heat Baffle ASM
98-1968	10	7	1	Rear Heat Baffle ASM
98-1969-03	2	7	1	Cooler Shroud ASM
98-1970-03	2	30	1	Bracket-Front
98-1972-03	2	15	1	Bracket-Rear
98-1979	10	29	1	Panel-Access
98-1982	3	39	1	Jumper
98-1985	8	52	1	Latch-ASM
98-1988	4	12	1	Torsion Shaft ASM
98-1990	4	8	1	Transfer Shaft ASM
98-1991	4	11	2	Link-Connect
98-1992	4	6	2	Link-Brake
98-1994	4	10	1	Brake Hub ASM
98-1995	7	29	1	Bumper
98-1996	4	25	2	Rod-Brake
98-1997	4	30	1	LH Brake Lever ASM
98-1998	4	24	1	RH Brake Lever ASM
98-1999-03	7	5	1	Panel-Instrument
98-3317	3	1	1	Harness-Wire
98-4350	2	2	1	Control-Throttle
98-4351	1	23:2	1	Rim
98-4357	7	3	1	Decal-Instrument

*Not Illustrated

Toro Part Number Index (cont.)

Part No.	Page No.	Ref. No.	Qty.	Description
98-4361	1	36	1	Decal-Warning
98-4367	4	34	2	Clevis-Adjustable
98-4370	8	56	1	Plug-Dome
98-4371	7	38	1	Cable-Seat
98-4373	3	40	1	Harness-Adapter
98-4374	6	46	1	Pump-Hydraulic
98-4375	5	37	1	Pump-Hydraulic
98-4383	1	19	1	Decal-Patent Numbers
98-4384	5	13	2	Hose ASM - Hyd
98-4387	8	51	1	Decal-Ear Protection
98-4397	9	33	2	Damper-Bidirectional
99-0264	2	16	1	Engine-Kohler
2112-11	10	16	1	Clamp-Muffler
232-27	1	23:3	1	Valve Stem
232-27	1	26:2	2	Valve Stem
237-22	5	20:1	2	O-Ring
237-22	5	32:1	2	O-Ring
237-22	5	36:1	1	O-Ring
237-30	5	1:1	2	O-Ring
237-30	5	10:1	1	O-Ring
237-30	5	12:1	2	O-Ring
237-30	5	31:1	3	O-Ring
237-30	5	33:1	4	O-Ring
237-42	5	20:2	1	O-Ring
237-42	5	36:2	1	O-Ring
237-78	5	32:2	2	O-Ring
237-79	5	10:2	1	O-Ring
237-79	5	12:2	2	O-Ring
237-79	5	33:2	4	O-Ring
237-80	5	1:2	2	O-Ring
237-80	5	31:2	3	O-Ring
240-11	7	25	1	Grommet
242-50	1	27	8	Nut-Lug
2411-52	9	11	2	Rod-End RH
2411-53	9	20	2	Rod-End LH
2412-39	2	12	4	R-Clamp
2412-93	3	28	1	R-Clamp
2412-98	2	29	2	Clamp-Hose
2412-120	7	22	2	Clamp-R
254-61	1	7	2	Cup-Bearing
254-62	1	8	1	Cone-Bearing
254-70	1	5	1	Cone-Bearing & Seal
256-154	11	3:2	2	Bushing-Straight
282-2	4	31	2	Clevis
283-1	4	5	8	Pin-Clevis
283-66	9	26	4	Pin-Clevis
288-4	2	23	1	Cap-Pipe
302-5	9	37	3	Fitting-Grease
321-3	7	9:5	2	Screw-HH
321-4	3	16	2	Screw-HH
321-4	3	27	5	Screw-HH
321-4	4	18	8	Screw-HH
321-4	10	21	1	Screw-HH
322-2	8	47	2	Screw-HH
322-3	2	13	4	Screw-HH
322-3	3	22	4	Screw-HH
322-3	4	4	4	Screw-HH
322-3	7	35	4	Screw-HH
322-4	7	44	6	Screw-HH
322-5	5	6	4	Screw-HH
322-5	9	12	4	Screw-HH
322-10	6	44	1	Screw-HH

*Not Illustrated

Toro Part Number Index (cont.)

Part No.	Page No.	Ref. No.	Qty.	Description
322-10	7	28	2	Screw-HH
323-4	9	23	4	Screw-HH
323-5	10	22	3	Screw-HH
323-6	1	25	6	Screw-HH
323-6	9	30	3	Screw-HH
323-6	11	24	2	Screw-HH
323-7	7	39	2	Screw-HH
323-8	7	17	1	Screw-HH
323-8	9	28	2	Screw-HH
323-9	2	25	4	Screw-HH
323-9	7	24	1	Screw-HH
323-10	11	17	2	Screw-HH
323-11	11	2	2	Screw
323-18	4	27	4	Screw-HH
323-19	11	43	2	Screw-HH
323-31	11	31	1	Screw-Hhcs
324-4	10	19	1	Screw-HH
324-5	5	35	4	Screw-HH
325-2	1	14	2	Screw
325-24	1	18	1	Screw-HH
3212-10	11	21	1	Screw
3217-7	9	29	4	Nut-Lock
3217-27	3	4:3	2	Nut-HH
3218-3	9	25	4	Nut-HJ
3220-2	4	33	2	Nut-Jam
3220-2	9	10	2	Nut-Jam
3220-3	2	4	1	Nut-Hex Jam
3220-7	1	9	1	Nut-Jam
3220-20	4	32	2	Nut-Hex Jam
3220-20	9	8	2	Nut-Hex Jam
3230-2	7	43	1	Screw-CARR
3231-2	7	19	2	Screw-CARR
3233-27	1	4	4	Screw-CARR
3234-1	11	8	8	Screw-HHF
3234-4	2	6	6	Screw-HH
3234-4	5	17	2	Screw-HH
3234-4	10	4	4	Screw-HH
3234-11	11	40	4	Screw-HHF
3234-17	2	33	2	Screw-Hfh
3241-5	11	35	4	Set Screw
3246-3	11	33	2	Screw-HSH
3250-13	2	31	2	Screw-PPH
3250-29	2	17	5	Screw
3253-4	7	36	4	Washer-Lock
3253-5	10	23	3	Washer-Lock
3253-6	10	18	1	Washer-Lock
3255-25	3	4:2	2	Washer-Lock
3256-2	7	37	5	Washer-Flat
3256-6	8	54	1	Washer-Flat
3256-8	1	13	1	Washer-Flat
3256-14	3	34	3	Washer-Flat
3256-21	8	50	2	Washer-Flat
3256-22	3	15	4	Washer-Flat
3256-23	3	26	2	Washer-Flat
3256-23	4	3	4	Washer-Flat
3256-23	5	25	1	Washer-Flat
3256-23	7	6	8	Washer-Flat
3256-24	4	28	1	Washer-Flat
3256-24	7	12	3	Washer-Flat
3256-24	11	7	5	Washer-Flat
3256-25	11	22	1	Washer-Flat
3256-26	1	16	6	Washer-Flat

*Not Illustrated

Toro Part Number Index (cont.)

Part No.	Page No.	Ref. No.	Qty.	Description
3256-39	1	21	2	Washer-Flat
3256-39	9	15	1	Washer-Flat
3257-42	6	40	2	Key-Woodruff
3269-8	7	23	2	Rivet
3272-4	9	4	4	Pin-Cotter
3272-10	4	7	2	Pin-Cotter
3272-17	1	10	1	Pin-Cotter
3274-83	5	3	2	Screw-HSH
3274-93	5	39	8	Screw-HSH
3290-126	5	24	1	Screw-Hfh
3290-307	4	19	6	Pin-Hair
3290-343	1	33	2	Pin-Hair
3290-355	8	53	1	Pin-Hair
3290-357	7	32	1	Nut-Lock Flange
3290-378	2	28	A/R	Tie-Cable
3290-378	3	29	A/R	Tie-Cable
3290-378	6	42	A/R	Tie-Cable
3290-379	3	7	A/R	Tie-Cable
3296-2	2	1	2	Nut-Lock
3296-2	3	33	3	Nut-Lock
3296-6	11	38	1	Nut-Lock
3296-23	1	15	5	Nut-Lock
3296-23	6	45	8	Nut-Lock
3296-29	2	14	4	Nut-Lock
3296-29	2	34	2	Nut-Lock
3296-29	3	24	4	Nut-Lock
3296-29	4	1	4	Nut-Lock
3296-29	5	26	7	Nut-Lock
3296-29	7	31	9	Nut-Lock
3296-29	9	14	2	Nut-Lock
3296-39	1	2	6	Nut-Lock
3296-39	2	27	4	Nut-Lock
3296-39	4	29	4	Nut-Lock
3296-39	7	11	5	Nut-Lock
3296-39	9	35	7	Nut-Lock
3296-39	11	10	13	Nut-Lock
3296-42	3	21	5	Nut-Lock
3296-42	4	21	8	Nut-Lock
3296-42	10	20	1	Nut-Lock
3296-47	9	18	2	Nut-Lock
32103-22	3	10	4	Nut-Wing
32105-13	3	35	3	Screw-HH
32120-72	4	22	2	Ring-Retaining
32121-48	11	44	1	Pin-Roll
32121-93	4	9	1	Pin-Spiral
32121-103	9	22	2	Pin-Spring
32128-42	5	34	4	Nut-Hex Flange
32144-4	7	33	4	Screw-TAP
32144-10	2	11	2	Screw-HH
32144-11	7	7	4	Screw-TAP
32144-14	5	18	2	Screw-HWH
32144-14	7	27	4	Screw-HWH
32144-74	3	9	2	Screw
32144-124	7	4	6	Screw-PPH
32148-6	10	1:2	3	Insert
33093-00	10	10	1	Washer-Flat M6
33114-020	10	26	2	Screw-HH
340-4	5	33	4	Fitting-Hyd
340-77	5	36	1	Fitting-Hydraulic
340-89	5	1	2	Fitting-Hydraulic
340-94	5	20	1	Tee
340-97	5	32	2	Fitting-Hydraulic

*Not Illustrated

Toro Part Number Index (cont.)

Part No.	Page No.	Ref. No.	Qty.	Description
340-98	5	12	2	Fitting-Hyd
340-105	5	31	3	Fitting-Elbow
340-157	5	10	1	Fitting-Hydraulic
351-78	7	9:3	1	Edging
351-80	7	9:6	1	Edging Clip

