

TURF TRACER[®]

X-SERIES

For Serial Nos.
402,082,300 & Higher
Part No. 4503-848 Rev. A

Operator's Manual

⚠ WARNING

CALIFORNIA
Proposition 65 Warning

This product contains a chemical or chemicals known to the State of California to cause cancer, birth defects, or reproductive harm.

The engine exhaust from this product contains chemicals known to the State of California to cause cancer, birth defects, or other reproductive harm.

Important: It is a violation of California Public Resource Code Section 4442 or 4443 to use or operate the engine on any forest-covered, brush-covered, or grass-covered land unless the engine is equipped with a spark arrester, as defined in Section 4442, maintained in effective working order or the engine is constructed, equipped, and maintained for the prevention of fire.

To acquire a spark arrester for your unit, see your Engine Service Dealer.

For all models that do not have Exmark engines, please refer to the engine manufacturer's information included with the machine.

For models with Exmark engines, refer to this manual for information.

The gross or net horsepower (or torque) of this engine was laboratory rated by the engine manufacturer in accordance with the Society of Automotive Engineers (SAE) J1940 or J2723. As configured to meet safety, emission, and operating requirements, the actual engine horsepower (or torque) on this class of mower will be significantly lower.



If your Exmark dealer does not have the Exmark part in stock, Exmark will get the parts to the dealer the next business day or the part will be FREE Guaranteed!! (Some restrictions apply. See your participating Exmark Dealer for details.)

Introduction

CONGRATULATIONS on the purchase of your Exmark Mower. This product has been carefully designed and manufactured to give you a maximum amount of dependability and years of trouble-free operation.

This manual contains operating, maintenance, adjustment, and safety instructions for your Exmark mower.

BEFORE OPERATING YOUR MOWER, CAREFULLY READ THIS MANUAL IN ITS ENTIRETY.

By following the operating, maintenance, and safety instructions, you will prolong the life of your mower, maintain its maximum efficiency, and promote safe operation.

Important: To maximize safety, performance, and proper operation of this machine, it is essential that all operators carefully read and fully understand the contents of the Operator's manual provided with the product. Safe operation of Exmark equipment is essential. Failure to comply with the operating instructions or receive proper training may result in injury. Go to <http://www.Exmark.com> for additional safe operation information, such as safety tips, training materials, and Operator's manuals.

If additional information is needed, or should you require trained mechanic service, contact your authorized Exmark equipment dealer or distributor.

All Exmark equipment dealers and distributors are kept informed of the latest methods of servicing and are equipped to provide prompt and efficient service in the field or at their service stations. They carry ample stock of service parts or can secure them promptly for you from the factory.

All Exmark parts are thoroughly tested and inspected before leaving the factory, however, attention is required on your part if you are to obtain the fullest measure of satisfaction and performance.

Whenever you need service, genuine Exmark parts, or additional information, contact an Authorized Service Dealer or Exmark Customer Service and have the model and serial numbers of your product ready.

Figure 1 identifies the location of the model and serial numbers on the product. Write the numbers in the space provided.

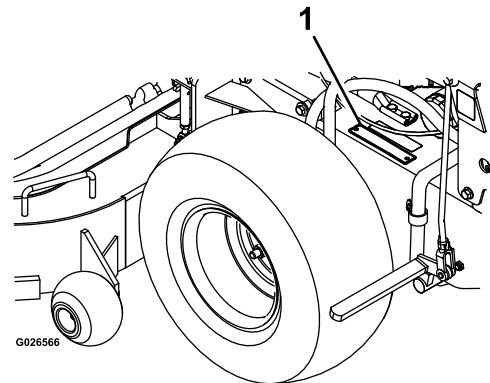

Figure 1

1. Model and serial number location

Model No. _____
Serial No. _____

For complete warranty details, see <http://www.Exmark.com>. You may also call us 402-223-6375 to request a written copy of the product's warranty.

Contents

Introduction	3	Clean Engine and Exhaust System	
Safety	5	Area	41
Safety Alert Symbol	5	Remove Engine Shrouds and Clean	
Safe Operating Practices	5	Cooling Fins	41
Safety and Instructional Decals	10	Clean Debris From Machine	41
Specifications	16	Clean Grass Build-Up Under Deck	41
Systems	16	Waste Disposal	41
Dimensions	17	Troubleshooting	43
Torque Requirements	18	Schematics	45
Product Overview	19		
Operation	19		
Controls	19		
Pre-Start	21		
Operating Instructions	21		
Transporting	25		
Maintenance	26		
Recommended Maintenance Schedule(s)	26		
Periodic Maintenance	27		
Check Engine Oil Level	27		
Check Mower Blades	29		
Check Safety Interlock System	29		
Check for Loose Hardware	32		
Service Air Cleaner	32		
Change Engine Oil	32		
Check Hydraulic Oil Level	32		
Check Tire Pressures	32		
Check Condition Of Belts	33		
Lubricate Grease Fittings	33		
Lubricate Caster Wheel Hubs	33		
Remove Engine Shrouds and Clean			
Cooling Fins	34		
Check Spark Plugs	34		
Change Hydraulic System Filter and			
Fluid	34		
Thread Locking Adhesives	36		
Mobil HTS Grease (Or Food-Grade			
Anti-seize)	37		
Copper-Based Anti-seize	37		
Dielectric Grease	37		
Adjustments	37		
Deck Leveling	37		
Pump Drive Belt Tension	37		
Deck Belt Tension	37		
Park Brake Adjustment	37		
Hydro Drive Linkage Adjustment	37		
Tracking Adjustment	40		
Hydro Pump Spring Tension Setting	40		
Electric Clutch Adjustment	40		
Cleaning	41		

Safety

Safety Alert Symbol

This lawn mower meets or exceeds the B71.4 specifications of the American National Standards Institute in effect at the time of production.

Exmark designed and tested this lawn mower to offer reasonably safe service; however, failure to comply with the following instructions may result in personal injury.

This Safety Alert Symbol (Figure 2) is used both in this manual and on the machine to identify important safety messages which must be followed to avoid accidents.

This symbol means: **ATTENTION! BECOME ALERT! YOUR SAFETY IS INVOLVED!**



Figure 2
Safety Alert Symbol

g000502

The safety alert symbol appears above information which alerts you to unsafe actions or situations and will be followed by the word **DANGER**, **WARNING**, or **CAUTION**.

DANGER: Indicates an imminently hazardous situation which, if not avoided, **Will** result in death or serious injury.

WARNING: Indicates a potentially hazardous situation which, if not avoided, **Could** result in death or serious injury.

CAUTION: Indicates a potentially hazardous situation which, if not avoided, **May** result in minor or moderate injury.

This manual uses two other words to highlight information. **Important** calls attention to special mechanical information and **Note** emphasizes general information worthy of special attention.

Safe Operating Practices

Training

- Read the Operator's Manual and other training material. If the operator(s) or mechanic(s) can not read this manual, it is the owner's responsibility to explain this material to them; other languages may be available on our website.
- Become familiar with the safe operation of the equipment, operator controls, and safety signs.
- All operators and mechanics should be trained. The owner is responsible for training the users.
- Never let children or untrained people operate or service the equipment. Local regulations may restrict the age of the operator.
- Only adults and mature teenagers should operate a mower, and even mature teenagers should have adult supervision. Be sure a teenager:
 1. has read and understands the Operator's Manual and recognizes the risks involved;
 2. is sufficiently mature to use caution; and
 3. is of sufficient size and weight to operate the controls comfortably and to manage the mower without taking risks.
- The owner/user can prevent and is responsible for accidents or injuries occurring to himself or herself, other people or property.

Preparation

- Evaluate the terrain to determine what accessories and attachments are needed to properly and safely perform the job. Only use accessories and attachments approved by Exmark.
- Wear appropriate clothing including safety glasses, substantial slip-resistant footwear, and hearing protection. Long hair, loose clothing or jewelry may get tangled in moving parts.

⚠ CAUTION

This machine produces sound levels in excess of 85 dBA at the operator's ear and can cause hearing loss through extended periods of exposure.

Wear hearing protection when operating this machine.

- Inspect the area where the equipment is to be used and remove all rocks, toys, sticks, wires,

bones, and other foreign objects which can be thrown by the machine and may cause personal injury to the operator or bystanders.

▲ DANGER

In certain conditions gasoline is extremely flammable and vapors are explosive.

A fire or explosion from gasoline can burn you, others, and cause property damage.

- Fill the fuel tank outdoors on level ground, in an open area, when the engine is cold. Wipe up any gasoline that spills.
- Never refill the fuel tank or drain the machine indoors or inside an enclosed trailer.
- Do Not fill the fuel tank completely full. Fill the fuel tank to the bottom of the filler neck. The empty space in the tank allows gasoline to expand. Overfilling may result in fuel leakage or damage to the engine or emission system.
- Never smoke when handling gasoline, and stay away from an open flame or where gasoline fumes may be ignited by spark.
- Store gasoline in an approved container and keep it out of the reach of children.
- Add fuel before starting the engine. Never remove the cap of the fuel tank or add fuel when engine is running or when the engine is hot.
- If fuel is spilled, Do Not attempt to start the engine. Move away from the area of the spill and avoid creating any source of ignition until fuel vapors have dissipated.
- Do Not operate without entire exhaust system in place and in proper working condition.

▲ DANGER

In certain conditions during fueling, static electricity can be released causing a spark which can ignite gasoline vapors. A fire or explosion from gasoline can burn you and others and cause property damage.

- Always place gasoline containers on the ground away from your vehicle before filling.
- Do Not fill gasoline containers inside a vehicle or on a truck or trailer bed because interior carpets or plastic truck bed liners may insulate the container and slow the loss of any static charge.
- When practical, remove gas-powered equipment from the truck or trailer and refuel the equipment with its wheels on the ground.
- If this is not possible, then refuel such equipment on a truck or trailer from a portable container, rather than from a gasoline dispenser nozzle.
- If a gasoline dispenser nozzle must be used, keep the nozzle in contact with the rim of the fuel tank or container opening at all times until fueling is complete. Do Not use a nozzle lock open device.

▲ WARNING

Gasoline is harmful or fatal if swallowed. Long-term exposure to vapors has caused cancer in laboratory animals. Failure to use caution may cause serious injury or illness.

- Avoid prolonged breathing of vapors.
 - Keep face away from nozzle and gas tank/container opening.
 - Keep away from eyes and skin.
 - Never siphon by mouth.
- Check that the operator presence controls, safety switches, and shields are attached and functioning properly. Do Not operate unless they are functioning properly.

Operation

⚠ WARNING

Operating engine parts, especially the muffler, become extremely hot. Severe burns can occur on contact and debris, such as leaves, grass, brush, etc. can catch fire.

- Allow engine parts, especially the muffler, to cool before touching.
- Remove accumulated debris from muffler and engine area.

⚠ WARNING

Engine exhaust contains carbon monoxide, which is an odorless deadly poison that can kill you.

Do Not run engine indoors or in a small confined area where dangerous carbon monoxide fumes can collect.

- Operate only in daylight or good artificial light, keeping away from holes and hidden hazards.
- Lightning can cause severe injury or death. If lightning is seen or thunder is heard in the area, Do Not operate the machine; seek shelter.
- Be sure all drives are in neutral and parking brake is engaged before starting engine.
- Never raise deck with blades running.
- Never operate the mower with damaged guards, shields, or covers. Always have safety shields, guards, switches and other devices in place and in proper working condition.
- Never mow with the discharge deflector raised, removed or altered unless there is a grass collection system or mulch kit in place and working properly.
- Do Not change the engine governor setting or overspeed the engine.
- Park machine on level ground. Stop engine, wait for all moving parts to stop, remove key and engage parking brake:
 - Before checking, cleaning or working on the mower.
 - After striking a foreign object or abnormal vibration occurs (inspect the mower for damage and make repairs before restarting and operating the mower).

- Before clearing blockages.
- Whenever you leave the mower.
- Stop engine, wait for all moving parts to stop, and engage parking brake:
 - Before refueling.
 - Before dumping the grass catcher.
 - Before making height adjustments.

⚠ WARNING

Hands, feet, hair, clothing, or accessories can become entangled in rotating parts. Contact with the rotating parts can cause traumatic amputation or severe lacerations.

- Do Not operate the machine without guards, shields, and safety devices in place and working properly.
- Keep hands, feet, hair, jewelry, or clothing away from rotating parts.
- NEVER carry passengers. DO NOT operate the mower when people, especially children, or pets are in the area.
- Be alert, slow down and use caution when making turns. Look behind and to the side before changing directions.
- Stop the blades, slow down, and use caution when crossing surfaces other than grass and when transporting the mower to and from the area to be mowed.
- Be aware of the mower discharge path and direct discharge away from others.
- Do Not operate the mower under the influence of alcohol or drugs.
- Use extreme care when loading or unloading the machine into a trailer or truck.
- Use care when approaching blind corners, shrubs, trees, or other objects that may obscure vision.

Slope Operation

- Slopes are a major factor related to loss of control and rollover accidents, which can result in severe injury or death. The operator is responsible for safe slope operation. Operating the machine on any slope requires extra caution. Before using the machine on a slope, the operator must:
 - Review and understand the slope instructions in the manual and on the machine

Safety

- Evaluate the site conditions of the day to determine if the slope is safe for machine operation. Use common sense and good judgment when performing this evaluation. Changes in the terrain, such as moisture, can quickly affect the operation of the machine on a slope.
- Operate across slopes, never up and down. Avoid operation on excessively steep or wet slopes. Poor footing could cause a slip and fall accident.
- Identify hazards at the base of the slope. Do not operate the machine near drop offs, ditches, embankments, water or other hazards. The machine could suddenly roll over if a wheel goes over the edge or the edge collapses. Keep a safe distance between the machine and any hazard. Use a hand held tool to operate in these areas.
- Avoid starting, stopping or turning the machine on slopes. Avoid making sudden changes in speed or direction; turn slowly and gradually.
- Do not operate a machine under any conditions where traction, steering or stability is in question. Be aware that operating the machine on wet grass, across slopes or downhill may cause the machine to lose traction. Loss of traction to the drive wheels may result in sliding and a loss of braking and steering. The machine can slide even if the drive wheels are stopped.
- Remove or mark obstacles such as ditches, holes, ruts, bumps, rocks or other hidden hazards. Tall grass can hide obstacles. Uneven terrain could overturn the machine.
- If you lose control of the machine, step away from the direction of travel of the machine.
- Always keep the machine in gear when going down slopes. Do not coast downhill.
- Let engine cool before storing and do not store near flame or any enclosed area where open pilot lights or heat appliances are present.
- Shut off fuel while storing or transporting. Do Not store fuel near flames or drain indoors.
- Park machine on level ground. Never allow untrained personnel to service machine.
- Use jack stands to support components when required.
- Carefully release pressure from components with stored energy.
- Disconnect battery or remove spark plug wire before making any repairs. Disconnect the negative terminal first and the positive last. Reconnect positive first and negative last.
- Use care when checking blades. Wrap the blade(s) or wear gloves, and use caution when servicing them. Only replace damaged blades. Never straighten or weld them.
- Keep hands and feet away from moving parts. If possible, do not make adjustments with the engine running.
- Charge batteries in an open well ventilated area, away from spark and flames. Unplug charger before connecting or disconnecting from battery. Wear protective clothing and use insulated tools.

⚠ DANGER

Charging or jump starting the battery may produce explosive gases. Battery gases can explode causing serious injury.

- **Keep sparks, flames, or cigarettes away from battery.**
- **Ventilate when charging or using battery in an enclosed space.**
- **Make sure venting path of battery is always open once battery is filled with acid.**
- **Always shield eyes and face from battery.**

Maintenance and Storage

- Disengage drives, set parking brake, stop engine and remove key or disconnect spark plug wire. Wait for all movement to stop before adjusting, cleaning or repairing.
- Keep engine and engine area free from accumulation of grass, leaves, excessive grease or oil, and other debris which can accumulate in these areas. These materials can become combustible and may result in a fire.

⚠ DANGER

Battery electrolyte contains sulfuric acid, which is poisonous and can cause severe burns. Swallowing electrolyte can be fatal or if it touches skin can cause severe burns.

- Wear safety glasses to shield eyes, and rubber gloves to protect skin and clothing when handling electrolyte.
- Do Not swallow electrolyte.
- In the event of an accident, flush with water and call a doctor immediately.

⚠ CAUTION

If the ignition is in the “ON” position there is potential for sparks and engagement of components. Sparks could cause an explosion or moving parts could accidentally engage causing personal injury.

Be sure ignition switch is in the “OFF” position before charging the battery.

- Keep all guards, shields and all safety devices in place and in safe working condition.
- Check all bolts frequently to maintain proper tightness.
- Frequently check for worn or deteriorating components that could create a hazard.

⚠ WARNING

Removal or modification of original equipment, parts and/or accessories may alter the warranty, controllability, and safety of the machine. Unauthorized modifications to the original equipment or failure to use original Exmark parts could lead to serious injury or death. Unauthorized changes to the machine, engine, fuel or venting system, may violate applicable safety standards such as: ANSI, OSHA and NFPA and/or government regulations such as EPA and CARB.

⚠ WARNING

Hydraulic fluid escaping under pressure can penetrate skin and cause injury. Fluid accidentally injected into the skin must be surgically removed within a few hours by a doctor familiar with this form of injury or gangrene may result.

- If equipped, make sure all hydraulic fluid hoses and lines are in good condition and all hydraulic connections and fittings are tight before applying pressure to hydraulic system.
- Keep body and hands away from pinhole leaks or nozzles that eject high pressure hydraulic fluid.
- Use cardboard or paper, not your hands, to find hydraulic leaks.
- Safely relieve all pressure in the hydraulic system by placing the motion control levers in neutral and shutting off the engine before performing any work on the hydraulic system.

For Kohler EFI (Electronic Fuel Injection) Units:

⚠ WARNING

Fuel system components are under high pressure. The use of improper components can result in system failure, gasoline leakage and possible explosion.

Use only approved fuel lines and fuel filters for high pressure systems.

Safety and Instructional Decals

- Keep all safety signs legible. Remove all grease, dirt and debris from safety signs and instructional labels.
- Replace all worn, damaged, or missing safety signs.
- When replacement components are installed, be sure that current safety signs are affixed to the replaced components.
- If an attachment or accessory has been installed, make sure current safety signs are visible.
- New safety signs may be obtained from your authorized Exmark equipment dealer or distributor or from Exmark Mfg. Co. Inc.
- Safety signs may be affixed by peeling off the backing to expose the adhesive surface. Apply only to a clean, dry surface. Smooth to remove any air bubbles.
- Familiarize yourself with the following safety signs and instruction labels. They are critical to the safe operation of your Exmark commercial mower.

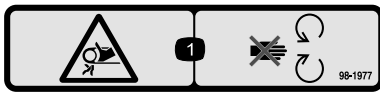

98-1977

decal98-1977

1. Entanglement hazard, belt—stay away from moving parts.

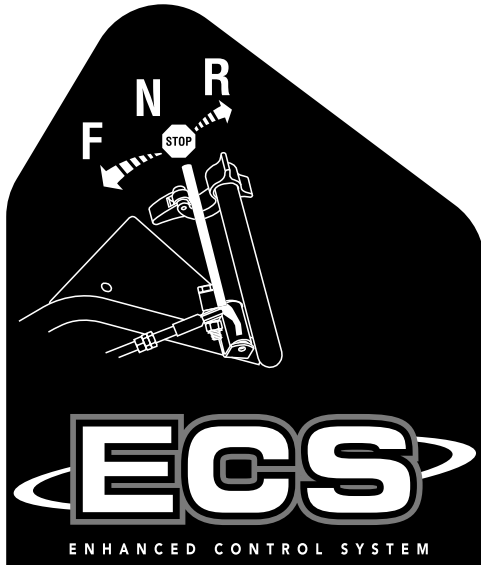

103-2242

decal103-2242

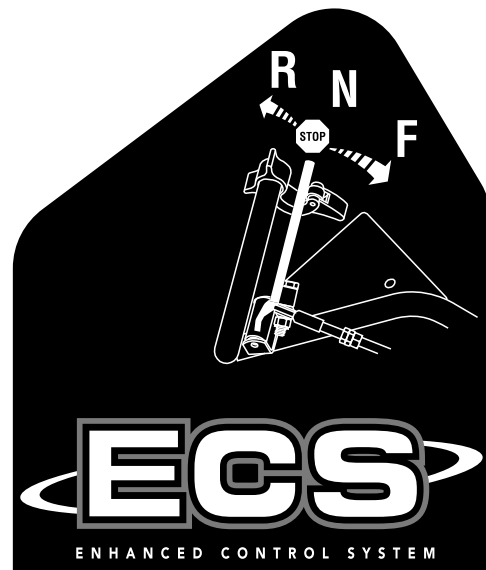

103-2243

decal103-2243



106-5517

decal106-5517

1. Warning—do not touch the hot surface.

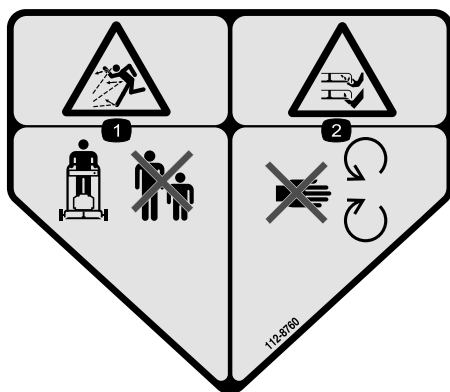

112-8760

decal112-8760

1. Thrown object hazard—keep bystanders a safe distance from the machine.
2. Cutting/dismemberment of hand or foot—stay away from moving parts.

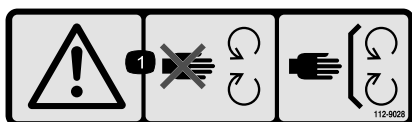

112-9028

decal112-9028

1. Warning—stay away from moving parts; keep all guards in place.

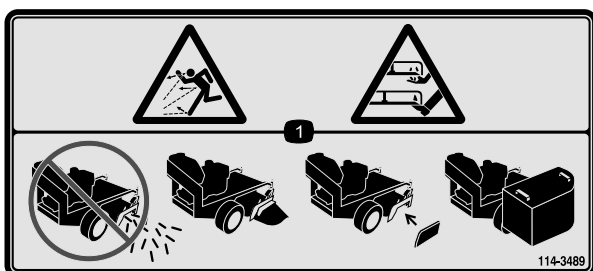

114-3489

decal114-3489

1. Thrown object hazard; cutting/dismemberment hazard—do not operate the machine with the discharge opening uncovered; always operate the machine with the rear discharge deflector, discharge cover or grass collector installed.

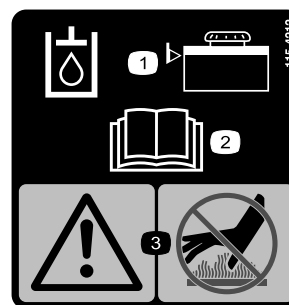

115-4212

decal115-4212

1. Hydraulic oil level
2. Read the *Operator's Manual*.
3. Warning—do not touch the hot surface.

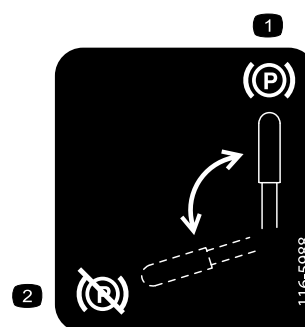

116-5988

decal116-5988

1. Parking brake—engaged
2. Parking brake—disengaged

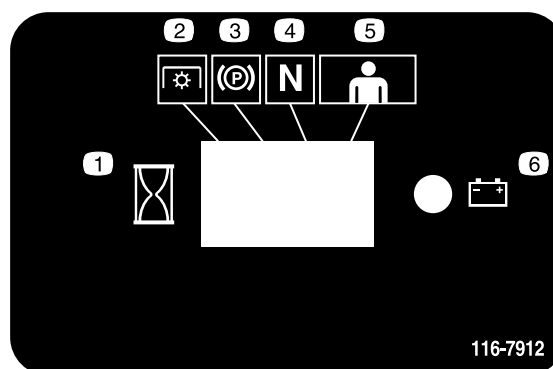

116-7912

decal116-7912

1. Interval
2. Power Take-off (PTO)
3. Parking brake
4. Neutral
5. Operator presence control
6. Battery

Safety

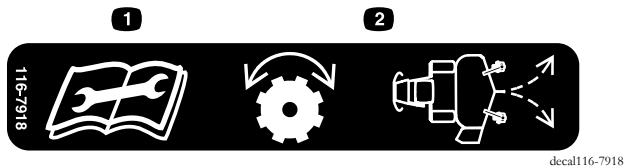

116-7918

1. Read the instructions before servicing or performing maintenance.
2. Turn knob to adjust tracking.

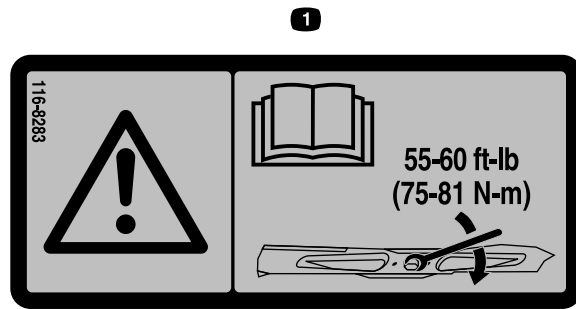

116-8283

1. Warning—read the Operator's Manual for instructions on torquing the blade bolt/nut to 55-60 ft-lb (75-81 N-m).

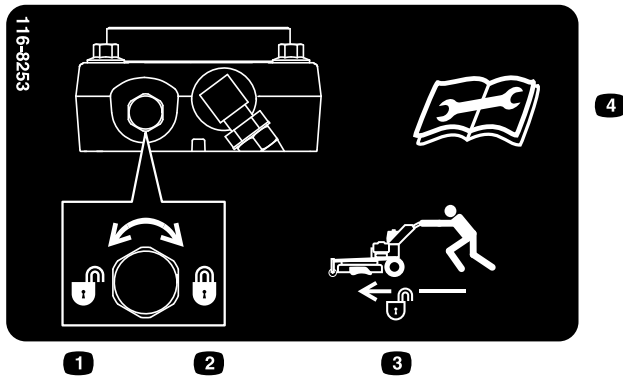

116-8253

1. Rotate counterclockwise to release.
2. Rotate clockwise to lock.
3. Unlock to push machine.
4. Read the instructions before servicing or performing maintenance.

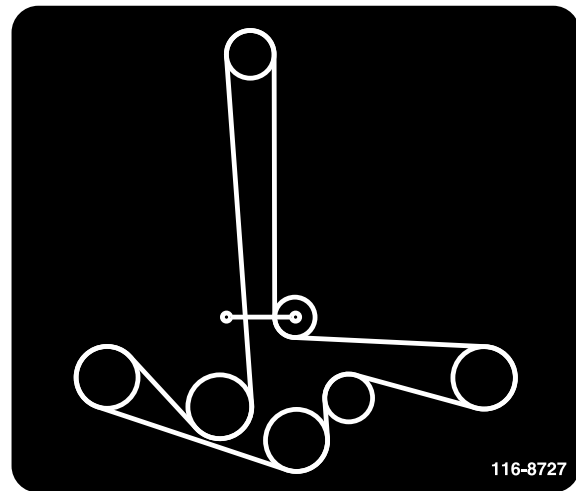

116-8727

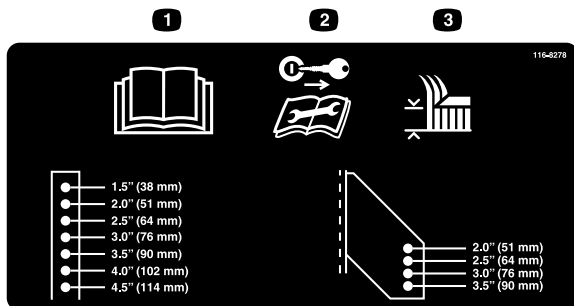

116-8278

1. Read the Operator's Manual.
2. Remove the ignition key and read the instructions before servicing or performing maintenance.
3. Height of cut



117-2718

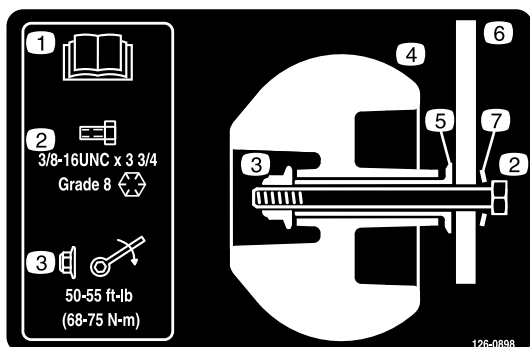

126-0898

decal126-0898

1. Read the Operator's manual
2. 3/8-16 x 3 3/4 inch bolt. Bolt must be Grade 8. Bolt and spring disc washer must be installed as shown.
3. Nyloc nut - torque to 50-55 ft-lb (68-75 N-m)
4. Roller
5. Bushing
6. Mount bracket
7. Spring disc washer

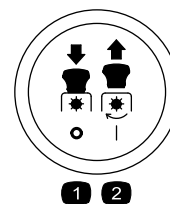

PTO Switch Symbols

decalptosymbols

1. PTO-disengage
2. PTO-engage

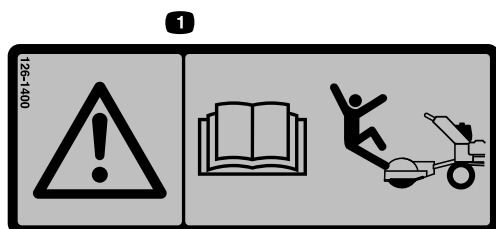

126-1400

decal126-1400

1. Warning-Read the Operator's manual. Use only Exmark riding attachments. Use of other riding attachments may create a hazardous condition resulting in injury.



126-2056

decal126-2056

1. Wheel lug nut torque 95 ft-lb (129 N-m) (4x)
2. Wheel hub nut torque 125 ft-lb (169 N-m)
3. Read and understand the Operator's manual before performing any maintenance, check torque after first 100 hours then every 500 hours thereafter.

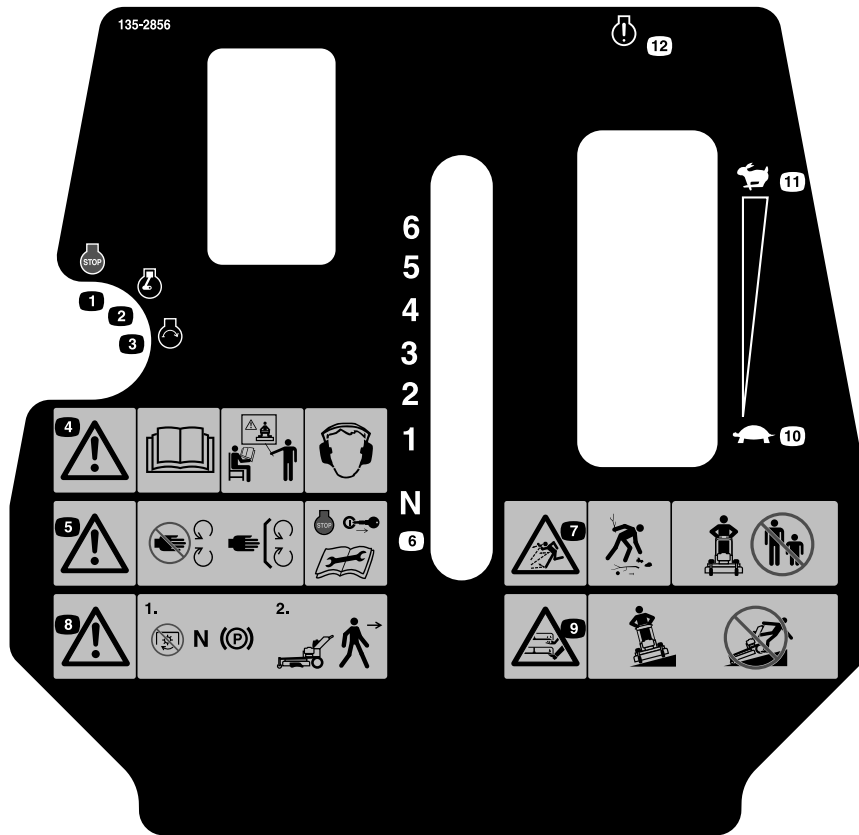

135-2856

EFI Models

decal135-2856

- | | |
|---|--|
| <ol style="list-style-type: none"> 1. Engine-off 2. Engine-on 3. Engine-start 4. Warning-Read the Operator's Manual. Do Not operate this machine unless you are trained. Wear hearing protection. 5. Warning-Stay away from moving parts; keep all guards in place. Stop engine and remove key before adjusting, servicing, or cleaning. 6. Neutral | <ol style="list-style-type: none"> 7. Thrown object hazard-Pick up objects that could be thrown by mower. Do Not operate when people and pets are in the area. Keep deflector in place. 8. Warning-Disengage PTO, shift speed control to neutral, and engage parking brake before leaving the operator's position. 9. Cutting/dismemberment hazard-Mow across slopes not up and down. Do Not mow wet slopes-use extreme caution when operating on slopes. 10. Throttle-slow 11. Throttle-fast |
|---|--|

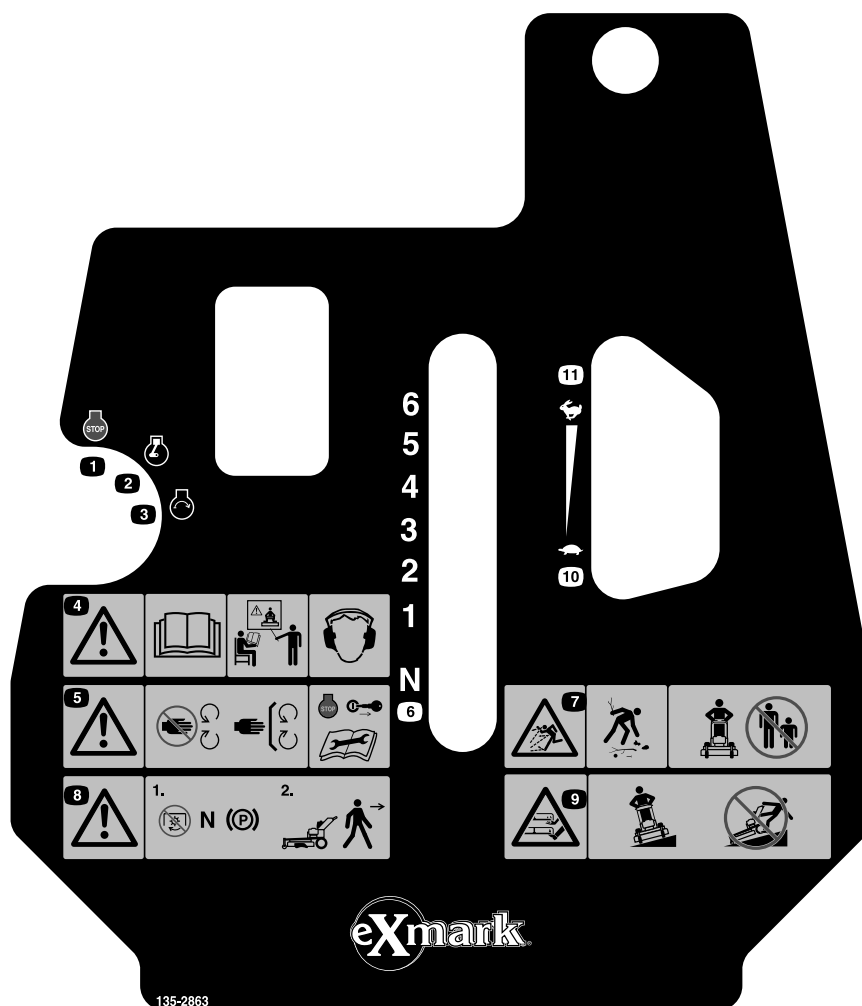

135-2863

All Models Except EFI

- | | |
|---|--|
| <ol style="list-style-type: none"> 1. Engine-off 2. Engine-on 3. Engine-start 4. Warning-Read the Operator's Manual. Do Not operate this machine unless you are trained. Wear hearing protection. 5. Warning-Stay away from moving parts; keep all guards in place. Stop engine and remove key before adjusting, servicing, or cleaning. 6. Neutral | <ol style="list-style-type: none"> 7. Thrown object hazard-Pick up objects that could be thrown by mower. Do Not operate when people and pets are in the area. Keep deflector in place. 8. Warning-Disengage PTO, shift speed control to neutral, and engage parking brake before leaving the operator's position. 9. Cutting/dismemberment hazard-Mow across slopes not up and down. Do Not mow wet slopes-use extreme caution when operating on slopes. 10. Throttle-slow 11. Throttle-fast |
|---|--|

Specifications

Systems

Engine

- Engine Specifications: See your Engine Owner's Manual
- Engine Oil Type: Exmark 4-Cycle Premium Engine Oil
- RPM: Full Speed: 3600 (No Load)
Idle: 1550 RPM

Fuel System

- Capacity: 5.0 gal. (18.9 L)
- Fuel Recommendations:
 - For best results, use only clean, fresh, unleaded gasoline with an octane rating of 87 or higher ((R+M)/2 rating method).
 - Oxygenated fuel with up to 10% ethanol or 15% MTBE by volume is acceptable.
 - **Do Not** use ethanol blends of gasoline (such as E15 or E85) with more than 10% ethanol by volume. Performance problems and/or engine damage may result which may not be covered under warranty.
 - **Do Not** use gasoline containing methanol.
 - **Do Not** store fuel either in the fuel tank or fuel containers over the winter unless a fuel stabilizer is used.
 - **Do Not** add oil to gasoline.
- Fuel Filter: Replaceable In-line
- Fuel Shut-Off Valve: 1/4 turn

Electrical System

- Charging System: Flywheel Alternator
- Charging Capacity:
 - Kawasaki: 15 amps
 - Kohler EFI: 20 amps
- Battery Type: BCI Group U1 235 amps 0°F
- Battery Voltage: 12 Volt
- Polarity: Negative Ground
- Fuses:

- Kawasaki: Two blade type, 20 amp to charging circuit; 20 amp to electric clutch-Quantity: 2
- Kohler EFI: Two blade type, 20 amp to charging circuit; 20 amp to electric clutch-Quantity: 1

Safety Interlock System:

- Operator must have OPC (Operator Presence Control) levers held in contact with handle grips, speed control lever in neutral, and PTO disengaged to start engine. Release of OPC levers will cause the engine to stop if speed control lever is not in neutral and/or PTO is engaged.
- Park brake must be disengaged to move speed control out of neutral or engine will initiate shutdown.

Operator Controls

Steering Control: Fingertip drive control levers provide independent speed control, braking and neutral to each drive wheel for moving forward or reverse, stopping, and power turning.

Transmission

- Two Hydro Gear variable displacement piston pumps independently coupled to two high efficiency Parker wheel drive motors.
- Hydraulic Oil: Use Exmark Premium Hydro Oil.
- Hydraulic Oil Capacity: 2.4 qt. (2.2 L)
- Hydraulic Filter is replaceable cartridge type.
P/N 109-4180: 25 microns, 10 psi bypass (Summer use above 32°F (0°C))
P/N 1-523541: 40 microns, 18 psi bypass (Winter use below 32°F (0°C))
- Speeds:
 - 0-6.75 mph (10.9 km/hr) forward.
 - 0-2.25 mph (3.6 km/hr) reverse.
- Drive wheel release valves allow machine to be moved when engine is not running.

Wheel Drive System

Drive wheels are direct coupled to Parker wheel drive motors with 1 inch (25.4 mm) tapered shaft.

Tires & Wheels

All Models Except "N0":

	Drive	Front Caster
	Pneumatic (Air-Filled)	Semi-Pneumatic
Quantity	2	2
Tread	Turf Master	Smooth
Size	18 x 8.50-8	11 x 4.00-5
Ply Rating	4	
Pressure	14 psi (96 kPa)	

"N0" Models:

	Drive	Front Caster	"N0" Tire
	Pneumatic (Air-Filled)	Semi-Pneumatic	Semi-Pneumatic
Quantity	2	2	1
Tread	Turf Master	Smooth	Smooth
Size	18 x 8.50-8	11 x 4.00-5	11 x 4.00-5
Ply Rating	4		
Pressure	14 psi (96 kPa)		

"N0" Models Only

For operator's over 250 lb (113 kg), it is recommended to use pneumatic tire assembly P/N 103-3798.

Cutting Deck

- Cutting Width:
 - 52 inch (132.1 cm)
 - 60 inch (152.4 cm)
- Discharge: Side
- Blade Size: (3 ea.)
 - 52 inch Deck: 18.00 inches (45.7 cm)
 - 60 inch Deck: 20.50 inches (52.1 cm)
- Blade Spindles: Solid steel spindles with 1 inch (25.4 mm) I.D. bearings.
- Deck Drive:
 - Electric clutch mounted on engine shaft.

- Blades driven by two belts (w/self-tensioning idlers).

- Deck:

Full floating deck is attached to out-front support frame, removable for service. Anti-scalp rollers provide maximum turf protection. Deck design allows for bagging, mulching or side discharge.

- Deck Depth:

- 52 inch Deck: 5.5 inches (14.0 cm)
- 60 inch Deck: 5.5 inches (14.0 cm)

- Cutting Height Adjustment:

Adjusts from 1 1/2 inches (3.8 cm) to 4 1/2 inches (11.4 cm) in 1/2 inch (1.3 cm) increments.

- Mulching Kit: Optional

- Bagger: Optional

Dimensions

Overall Width:

All Models:

	52 inch Deck	60 inch Deck
Deflector Up	53.4 inches (135.6 cm)	61.4 inches (156.0 cm)
Deflector Down	64.8 inches (164.6 cm)	73.0 inches (185.4 cm)

Overall Length:

All Models Except "N0":

52 inch Deck	60 inch Deck
84.75 inches (215.3 cm)	84.75 inches (215.3 cm)

"N0" Models:

60 inch Deck
104.8 inches (266.2 cm)

Specifications

Overall Height:

All Models:

52 inch Deck	60 inch Deck
45 inches (114.3 cm)	45 inches (114.3 cm)

Tread Width: (Outside to Outside of Tires, Widthwise)

All Models:

52 inch Deck	60 inch Deck
45.8 inches (116.3 cm)	45.8 inches (116.3 cm)

Wheel Base: (Center of Caster Tire to Center of Drive Tire)

All Models:

52 inch Deck	60 inch Deck
43.3 inches (110.0 cm)	43.3 inches (110.0 cm)

Curb Weight:

All Models Except "N0":

52 inch Deck	60 inch Deck
720 lb (327 kg)	760 lb (345 kg)

"N0" Models:

60 inch Deck
840 lb (381 kg)

Torque Requirements

Bolt Location	Torque
Cutter Housing Spindle Nut	140–145 ft-lb (190–197 N-m)
Blade Mounting Bolt (lubricate with anti-seize)	55-60 ft-lb (75-81 N-m)
Engine Deck/Mower Deck Support Mount Bolts	30-35 ft-lb (41-47 N-m)
Anti-Scalp Roller Nyloc Nut (See Figure 8)	50-55 ft-lb (68-75 N-m)
Engine Mounting Bolts — Kohler	15-20 ft-lb (20-27 N-m)
Engine Mounting Bolts — Kawasaki	17-23 ft-lb (23-31 N-m)
Wheel Lug Nuts	85-105 ft-lb (115-142 N-m)
Clutch Retaining Bolt (secured with threadlocker)	55-60 ft-lb (75-81 N-m)
Wheel Motor Mounting Bolts	30-35 ft-lb (41-47 N-m)
Muffler Guard Mounting Bolts	30-35 ft-lb (41-47 N-m)

Product Overview

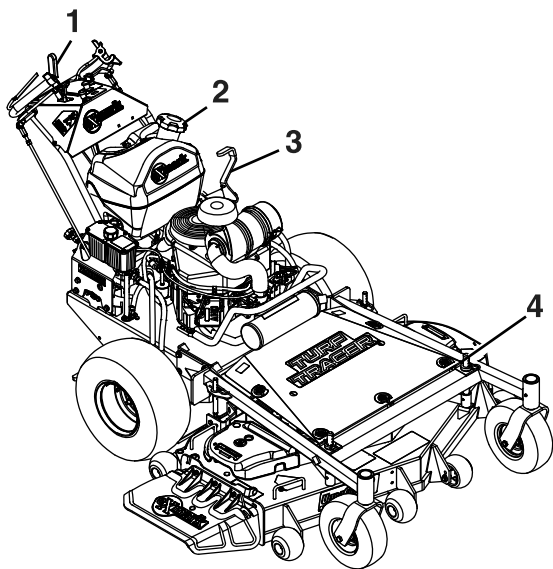

Figure 3

g227933

- | | |
|-------------|-----------------------|
| 1. Controls | 3. Park Brake Lever |
| 2. Fuel Cap | 4. Height-of-Cut Pins |

Operation

Note: Determine the left and right sides of the machine from the normal operating position.

Controls

Operator Presence Control (OPC) Levers

Located on the upper handle assembly directly above the handle grips.

When these levers are depressed, the OPC system senses that the operator is in the normal operator's position. When the levers are released, the OPC system senses that the operator has moved from the normal operating position and will shutdown the engine if either the speed control lever is not in the neutral position or the PTO is engaged (see Figure 4).

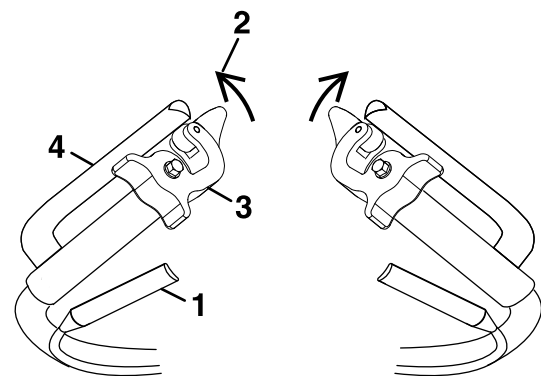

Figure 4

g227574

- | | |
|--|------------------------------------|
| 1. OPC Lever | 3. Neutral Lock Latch |
| 2. Rotate neutral lock latch for neutral lock position | 4. Drive Lever in neutral position |

Drive Levers

Located on each side of the upper handle assembly ahead of and below the handle grips.

These levers individually control the speed and direction of each drive wheel. When the speed control lever is moved out of the neutral position and the neutral lock latches are moved into the drive position, as shown in Figure 4, and the drive levers are released, the drive wheels are engaged in the forward direction.

Squeezing the left hand and/or right hand lever causes the left hand and/or right hand drive wheel respectively to slow down, stop, or reverse, depending

Operation

on how far each drive lever is “squeezed”. Squeezing the drive levers beyond the neutral position causes the drive wheels to engage in the reverse direction regardless of the position of the neutral lock latches and the speed control lever.

Neutral Lock Latches

Located on the upper handle assembly on the ends of the handle grips.

These latches allow the operator to lock the drive levers in a “neutral” position where the drive wheels are not engaged in either a forward or reverse direction.

Choke Control (All Units Except Kohler EFI)

Located on the control console front right hand side.

Choke is used to aid in starting a cold engine. The choke control is pulled out to be in the “ON” position and pushed in to be in the “OFF” position. Do Not run a warm engine with choke in the “ON” position.

Throttle Control

Located on the control console’s right side.

The throttle is used to control engine speed. Moving the throttle control forward will increase engine speed and moving it to the rear will decrease engine speed. Moving the throttle forward into the detent is full position.

Speed Control Lever

Located in middle of control console.

The speed control lever controls the maximum forward speed and is infinitely variable from neutral 0–6.75 mph (10.9 km/hr).

Park brake must be disengaged to move speed control out of neutral or engine will initiate shutdown.

Park Brake Lever

Located on the left side of the unit.

The brake lever engages the park brake on the drive wheels.

Pull the lever up and rearward to engage the brake.

Push the lever forward and down to disengage the brake.

When parking on a steep slope, the wheels must be chocked or blocked in addition to the brake being engaged. The unit must be tied down and brake engaged when transporting.

The park brake must be disengaged to move speed control out of neutral or engine will initiate shutdown.

Ignition Switch

Located on the left side of the control console.

The ignition switch is used to start and stop the engine. The ignition switch has three positions, “Off”, “On” and “Start”. Insert key into switch and rotate clockwise to the “On” position. Rotate clockwise to the next position to engage the starter (key must be held against spring pressure in this position). Operator must have speed control lever in neutral, OPC levers depressed and PTO disengaged to start engine. When engine starts, release key.

Hour Meter

Located on the front left hand side of console just above the PTO switch.

The hour meter is connected to a pressure switch installed in the engine block and it records the number of hours that the engine has run. If ignition switch is left on without engine running, hour meter will not run.

Note: This switch is not a low oil sensor and will not alert the operator if the engine oil is low.

Fuel Shut-Off Valve

Located in the fuel line midway between the tank and engine.

The fuel shut-off valve is used to shut off the flow of fuel when parking inside a building, during transportation to and from the job sites, and when the machine will not be used for a few days.

Rotate valve 1/4 turn clockwise to shut fuel off. Rotate valve 1/4 turn counterclockwise to turn fuel on.

Drive Wheel Release Valves

Located on the left rear corner of the hydrostatic pumps.

Drive wheel release valves are used to release the hydrostatic drive system to allow the machine to be moved by hand without the engine running.

With a 5/8 wrench, turn both valves one turn counterclockwise to release the drive system.

Turn clockwise to reset the drive system. **Do Not overtighten.**

Tracking Adjustment Knob

Located on the right-hand side of the rear of the fuel tank support.

The knob can be adjusted so that machine will “track” straight ahead with the drive levers released.

PTO Engagement Switch

Switch is located on left side of control console.

The switch must be pulled out to the “Rotate” position to engage the blades. The switch is pushed in to the “Stop” position to stop the blades. Operator must have operator presence control levers depressed when PTO is engaged or engine will stop.

Electronic Control Unit Malfunction Indicator

Kohler EFI Units Only:

The electronic control unit (ECU) continuously monitors operation of the EFI system. If a problem or fault within the system is detected, the malfunction indicator light (MIL) is illuminated. The MIL is the light located in the right console panel to the right of the throttle control. Follow the troubleshooting steps outlined in the Kohler engine operator’s manual if the MIL is illuminated.

Pre-Start

Fill fuel tank on level ground. See **Fuel Recommendations** in the Specifications section for additional gasoline information.

Do Not add oil to gasoline.

Do Not overfill fuel tank. Fill the fuel tank to the bottom of the filler neck. The empty space in the tank allows gasoline to expand. Overfilling may result in fuel leakage or damage to the engine or emission system.

Make sure you understand the controls, their locations, their functions, and their safety requirements.

Refer to the Maintenance section and perform all the necessary inspection and maintenance steps.

Operating Instructions

Open the Fuel Shut-Off Valve

Rotate the valve 1/4 turn counterclockwise to turn fuel on.

Starting the Engine

Note: It is helpful to have the left and right neutral lock latches locked in neutral when starting the engine. Refer to **Neutral Lock Latches** section in Controls.

Note: Operator must have PTO disengaged, speed control lever in neutral position, and OPC levers depressed when starting the engine.

1. On a cold engine, place the throttle midway between the “Slow” and “Fast” positions and place the choke in the “On” position (except on Kohler EFI units).

On a warm engine, place the throttle lever midway between “Slow” and “Fast” positions and leave the choke in the “Off” position.

Note: Kawasaki engines generally need to be “choked” even when warm.

2. Turn ignition switch to “Start” position. Release the switch as soon as the engine starts.

Important: Do not crank the engine continuously for more than ten seconds at a time. If the engine does not start, allow a 60 second starter cool-down period between starting attempts. Failure to follow these guidelines can burn out the starter motor.

3. After engine warms up, gradually push in the choke control. Do Not run warm engine with the choke in the “ON” position.

Operation

Engaging the PTO

▲ DANGER

The rotating blades under the mower deck are dangerous. Blade contact can cause serious injury or kill you.

Do Not put hands or feet under the mower or mower deck when the blades are engaged.

▲ DANGER

An uncovered discharge opening will allow objects to be thrown in an operator's or bystander's direction. Also, contact with the blade could occur. Thrown objects or blade contact can cause serious injury or death.

Never operate the mower with the discharge deflector raised, removed, or altered unless there is a grass collection system or mulch kit in place and working properly.

The PTO switch engages the cutting blades. Be sure that all persons are clear of mower deck and discharge area before engaging the PTO.

1. Set throttle to "MIDWAY" position.
2. Pull the PTO switch outward to the "ROTATE" position to engage the blades.
3. Place the throttle in the "FAST" position to begin mowing.

Disengaging the PTO

1. Set the throttle to the "MIDWAY" position.
2. Push the PTO switch in to the "STOP" position to disengage the blades.

Stopping the Engine

1. Disengage the PTO.
2. Bring the unit to a full stop.
3. Lock drive levers in neutral.
4. Move speed control lever to neutral.
5. Engage the parking brake.
6. Place the throttle midway between the "SLOW" and "FAST" positions.

7. Allow the engine to run for a minimum of 15 seconds, then turn the ignition switch to the "OFF" position to stop the engine.
8. Remove the key to prevent children or other unauthorized persons from starting engine.
9. Close the fuel shut-off valve when the machine will not be in use for a few days, when transporting, or when the unit is parked inside a building.

Driving the Machine

Drive Lever/Neutral Lock Latch Operation

To lock the drive levers in "neutral lock", squeeze the drive levers to the "neutral" position (Do Not squeeze the drive levers all the way back as this will cause the drive wheels to go into full reverse direction). See Figure 5 position 1. Place thumbs on the inner lobe of the neutral lock latches and rotate them under the drive levers into the "neutral lock" position. See Figure 5 position 2. Release the drive levers.

▲ CAUTION

If the neutral lock latches are not completely engaged the drive levers could unexpectedly slip into the forward drive position. If the drive levers slip into the drive position the unit could lurch forward and cause injury or property damage.

Be sure the drive levers are past the roller and securely seated at the bottom of the neutral lock latches.

To place the drive levers in the "forward" position, slightly squeeze the drive levers while placing thumbs on the outer thumb lobe of the neutral lock latches (or the index finger on the front lobe) and rotate them from under the drive levers. Slowly and carefully release the drive levers. See Figure 5 position 3.

To place the drive levers in the "reverse" position, squeeze the drive levers past the neutral position. See Figure 5 position 4.

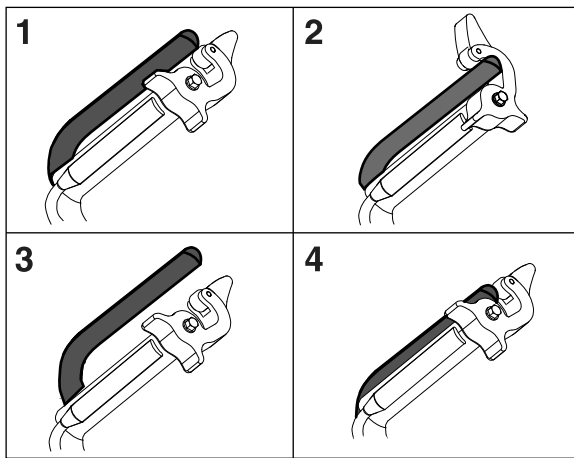

Figure 5
Left Hand Control Shown

- | | |
|---|------------------------------------|
| 1. Drive Lever in neutral position | 3. Drive Lever in forward position |
| 2. Drive Lever locked in neutral position | 4. Drive Lever in reverse position |

Driving Forward

1. Release the parking brake.
2. With drive levers locked in “neutral”, shift speed control lever to desired forward speed.
3. Slowly squeeze and hold both drive levers in the neutral position and rotate both neutral lock latches from the neutral lock position to the forward position.

Note: Do Not squeeze both drive levers all the way back. This will cause the drive wheels to engage in the reverse direction.

4. To move forward in a straight line, smoothly release both drive levers to engage drive wheels.

To turn left or right, squeeze the right hand drive lever to turn right and the left hand drive lever to turn left.

To make a “zero turn”, squeeze either the left hand or the right hand drive lever back into the reverse position while the opposite drive lever is in a forward position at an equal but opposite speed.

Note: For smooth operation of this machine, avoid quick, jerky movements of the drive levers. Move the drive levers smoothly and deliberately.

To stop, squeeze drive levers back to the “neutral” position. Move the neutral lock latches into the “neutral lock” position and release drive levers.

Move the speed control lever to the neutral position.

Driving in Reverse

To move rearward in a straight line, squeeze drive levers into the reverse position.

To turn left or right, squeeze the right hand drive lever to turn left and the left hand drive lever to turn right.

To make a “zero turn”, squeeze either the left hand or the right hand drive lever back into the reverse position while the opposite drive lever is in a forward position at an equal but opposite speed.

Note: For smooth operation of this machine, avoid quick, jerky movements of the drive levers. Move the drive levers smoothly and deliberately.

To stop, squeeze drive levers back to the “neutral” position. Move the neutral lock latches into the “neutral lock” position and release drive levers. Move the speed control lever to the neutral position.

Adjusting the Cutting Height

▲ WARNING

When the two front support rod hairpins are removed from the mower deck, the weight of the tractor section may cause the front frame of the unit to rise suddenly. If the unit rises suddenly, injury may occur.

Securely hold down the front of the unit when the front support rod hairpins are removed.

The cutting height of the mower deck is adjusted from 1 1/2 to 4 1/2 inches (3.81 cm to 11.4 cm) in 1/2 inch increments.

1. Disengage the PTO.
2. Bring the unit to a full stop.
3. Lock drive levers in neutral.
4. Move speed control lever to neutral.
5. Engage the parking brake.
6. Stop the engine, remove the key and wait for all moving parts to stop.
7. Install hairpin clips in the holes for the desired cutting height. See Figure 6.

Important: To maintain correct cutting height and rake, check the following for proper adjustment.

Operation

- A. The front and rear hairpins are in the same holes with the proper spacers under the hair pins. See Figure 6.

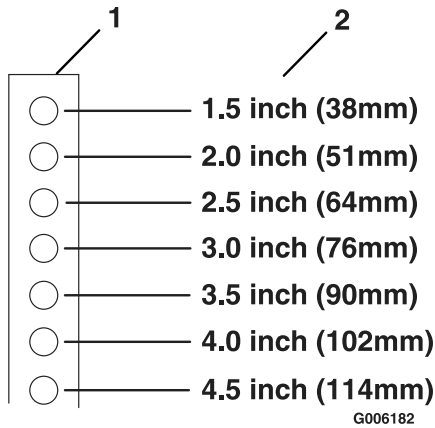

Figure 6

1. Deck support pin 2. Cutting Height

- B. The tire pressures are set as directed in **Check Tire Pressures** in the Maintenance section.
- C. The length of the rear deck support link assemblies average 6.89 inches (approximately 6 7/8 inches) (175.01 mm) from the center of the balljoint to the center of the farthest hole. See Figure 7.

Note: All four pins must equally support the weight of the deck. Adjustment in the length of the rear deck support assemblies may be necessary. If one side is longer than 6.89 inches (approximately 6 7/8 inches) (175.01 mm), than the opposite side must be shorter by the same amount.

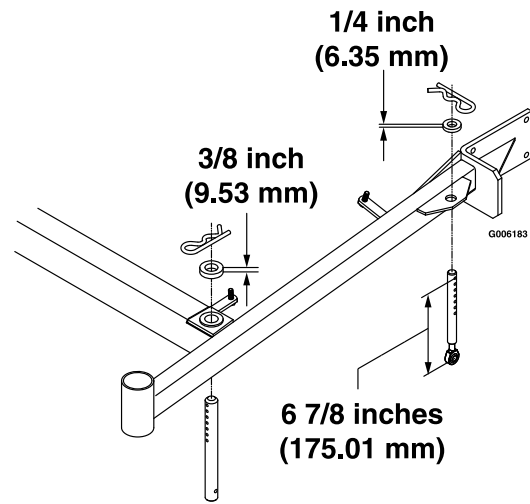

Figure 7

Left Hand Side Shown

G006183

Adjusting the Anti-Scalp Rollers

It is recommended to change the anti-scalp roller position when the height of cut has changed.

1. Disengage the PTO.
2. Bring the unit to a full stop.
3. Lock drive levers in neutral.
4. Move speed control lever to neutral.
5. Engage the parking brake.
6. Stop the engine, remove the key and wait for all moving parts to stop.
7. After adjusting the height of cut, adjust the anti-scalp rollers by removing the nyloc nut, spring disc washer, and bolt.
8. Adjust anti-scalp rollers for Normal Operating Conditions. Place rollers in one of the positions shown in Figure 8. Rollers will maintain 3/4 inches (19 mm) clearance to the ground to minimize gouging and roller wear or damage.

Note: For Maximum Deck Flotation, place rollers one hole position lower. Rollers should maintain 1/4 inch (6.35 mm) clearance to ground. Do Not adjust rollers to support the deck.

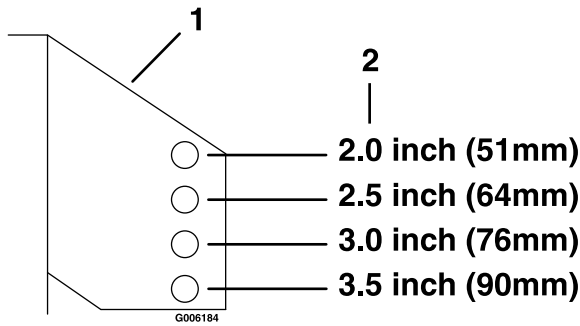

Figure 8

For cutting heights above 3.5 inches (38 mm) use the bottom hole. The rollers will still be effective against scalping.

- | | |
|---------------------------------------|-------------------|
| 1. Anti-scalp roller mounting bracket | 2. Cutting height |
|---------------------------------------|-------------------|

9. Be sure roller bolts are installed with the spring disc washer between head of the bolt and mounting bracket.
10. Torque the 3/8-16 nyloc nut to 50–55 ft-lb (68-75 N-m) (Figure 9).

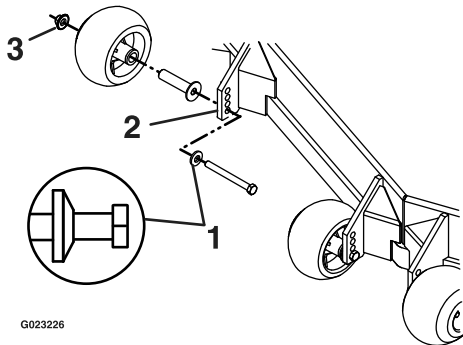

Figure 9

- | | |
|---|--|
| 1. 3/8-16 x 3 3/4 Grade 8 bolt | 3. Front right anti-scalp bracket shown |
| 2. Spring disc washer (cone towards bolt) | 4. 3/8 nyloc-torque to 50–55 ft-lb (68-75 N-m) |

Transporting

Transporting a Unit

⚠ WARNING

Loading the mower onto a trailer without strong enough or properly supported ramps could be dangerous. The ramps could collapse causing the unit to fall, which could cause injury.

- Use proper ramps that are secured to the truck or trailer.
- Keep feet and legs out from under the unit when loading and unloading.
- If necessary, use assistance when loading.

Use full width ramps when loading the machine.

Be sure the fuel shut-off valve is closed during transport.

Use a heavy duty trailer to transport the machine. Engage neutral lock latches and park brake, then block wheels.

Securely fasten the machine to the trailer with straps, chains, cables, or ropes. If possible, both front and rear straps should be directed down and outward from the machine.

Do Not rely solely on the parking brake to hold the machine on the trailer.

Be sure that the trailer has all necessary lighting and marking as required by law and use a safety chain.

Maintenance

Note: Determine the left and right sides of the machine from the normal operating position.

⚠ WARNING

While maintenance or adjustments are being made, someone could start the engine. Accidental starting of the engine could seriously injure you or other bystanders.

Remove the key from the ignition switch, engage parking brake, and pull the wire(s) off the spark plug(s) before you do any maintenance. Also push the wire(s) aside so it does not accidentally contact the spark plug(s).

⚠ WARNING

The engine can become very hot. Touching a hot engine can cause severe burns.

Allow the engine to cool completely before service or making repairs around the engine area.

Recommended Maintenance Schedule(s)

Maintenance Service Interval	Maintenance Procedure
After the first 5 hours	<ul style="list-style-type: none"> Change the engine oil.
After the first 250 hours	<ul style="list-style-type: none"> Change hydraulic system filter and fluid.
Before each use or daily	<ul style="list-style-type: none"> Check the engine oil level. Check the mower blades. Check the safety interlock system. Check for loose hardware. Clean the engine and exhaust system area. Clean the grass and debris build-up from the machine and cutting deck. Clean the grass build-up from under the deck.
Every 40 hours	<ul style="list-style-type: none"> Check the hydraulic oil level. Check the tire pressures. Check the condition of the belts. Grease the hydro control arm support bushings.
Every 80 hours	<ul style="list-style-type: none"> Remove engine shrouds and clean cooling fins.
Every 100 hours	<ul style="list-style-type: none"> Change the engine oil. (May need more often under severe conditions.) Remove engine shrouds and clean cooling fins.
Every 160 hours	<ul style="list-style-type: none"> Check the spark plugs.
Every 250 hours	<ul style="list-style-type: none"> Replace the primary air cleaner element — check secondary air cleaner element; replace if dirty. (May need more often under severe conditions. See the Engine manual for additional information.)
Every 500 hours	<ul style="list-style-type: none"> Replace the secondary air cleaner element. (May need more often under severe conditions. See the Engine manual for additional information.) Change hydraulic system filter and fluid (Every 250 hours/Yearly if using Mobil 1 15W50)
Yearly	<ul style="list-style-type: none"> Grease the front caster wheel hubs. Grease front caster pivots. Grease the idler pivot (Mower Deck). Lubricate the caster wheel hubs.

Periodic Maintenance

Check Engine Oil Level

Service Interval: Before each use or daily

1. Stop engine and wait for all moving parts to stop. Make sure unit is on a level surface.
2. Check with engine cold.
3. Clean area around dipstick. Remove dipstick and wipe oil off. Reinsert the dipstick according to the engine manufacturer's recommendations. Remove the dipstick and read the oil level.
4. If the oil level is low, wipe off the area around the oil fill cap, remove cap and fill to the "FULL" mark on the dipstick. Exmark 4-Cycle Premium Engine Oil is recommended; refer to the Engine Owner's manual for an appropriate API rating and viscosity. **Do Not** overfill.

Important: Do Not operate the engine with the oil level below the "LOW" (or "ADD") mark on the dipstick, or over the "FULL" mark.

Check Battery Charge

Service Interval: As required

⚠ WARNING

**CALIFORNIA
Proposition 65 Warning**

Battery posts, terminals, and related accessories contain lead and lead compounds, chemicals known to the State of California to cause cancer and reproductive harm. Wash hands after handling.

Allowing batteries to stand for an extended period of time without recharging them will result in reduced performance and service life. To preserve optimum battery performance and life, recharge batteries in storage when the open circuit voltage drops to 12.4 volts.

Note: To prevent damage due to freezing, battery should be fully charged before putting away for winter storage.

Check the voltage of the battery with a digital voltmeter or with the message display. If the ignition key is turned to the "on" position for a few seconds, the battery voltage will be displayed in the area where the hours are normally displayed. Locate the voltage reading of the battery in the table and charge the battery for the recommended time interval to bring the charge up to a full charge of 12.6 volts or greater.

Important: Make sure the negative battery cable is disconnected and the battery charger used for charging the battery should have an output of 16 volts and 7 amps or less to avoid damaging the battery (see chart for recommended charger settings). This is especially important on Kohler EFI (Electronic Fuel Injection) units. Failure to do so may damage the ECU (Electronic Control Unit).

Voltage Reading	Percent Charge	Maximum Charger Settings	Charging Interval
12.6 or greater	100%	16 volts/7 amps	No Charging Required
12.4 – 12.6	75–100%	16 volts/7 amps	30 Minutes
12.2 – 12.4	50–75%	16 volts/7 amps	1 Hour
12.0–12.2	25–50%	14.4 volts/4 amps	2 Hours
11.7–12.0	0–25%	14.4 volts/4 amps	3 Hours
11.7 or less	0%	14.4 volts/2 amps	6 Hours or More

Important: For Kohler EFI units: Unplug the harness from the ECU before performing any welding on the equipment.

Recommended Jump Starting Procedure

Service Interval: As required

1. Check the weak battery for terminal corrosion (white, green, or blue "snow"), it must be cleaned off prior to jump starting. Clean and tighten connections as necessary.

Maintenance

⚠ CAUTION

Corrosion or loose connections can cause unwanted electrical voltage spikes at anytime during the jump starting procedure.

Do Not attempt to jump start with loose or corroded battery terminals or damage to the engine or EFI may occur.

⚠ DANGER

Jump starting a weak battery that is cracked, frozen, has low electrolyte level, or an open/shorted battery cell, can cause an explosion resulting in serious personal injury.

Do Not jump start a weak battery if these conditions exist.

2. Make sure the booster is a good and fully charged lead acid battery at 12.6 volts or greater. Use properly sized jumper cables (4 to 6 AWG) with short lengths to reduce voltage drop between systems. Make sure the cables are color coded or labeled for the correct polarity.

⚠ CAUTION

Connecting the jumper cables incorrectly (wrong polarity) can immediately damage the electrical and/or EFI system.

Be certain of battery terminal polarity and jumper cable polarity when hooking up batteries.

Note: The following instructions are adapted from the SAE J1494 Rev. Dec. 2001 – Battery Booster Cables – Surface Vehicle Recommended Practice (SAE – Society of Automotive Engineers).

⚠ WARNING

Batteries contain acid and produce explosive gases.

- Shield the eyes and face from the batteries at all times.
- Do Not lean over the batteries.

Note: Be sure the vent caps are tight and level. Place a damp cloth, if available, over any vent

caps on both batteries. Be sure the vehicles do not touch and that both electrical systems are off and at the same rated system voltage. These instructions are for negative ground systems only.

3. Connect the positive (+) cable to the positive (+) terminal of the discharged battery that is wired to the starter or solenoid as shown in Figure 10.

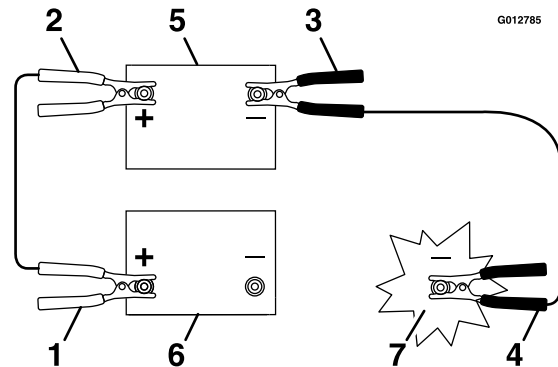

Figure 10

1. Positive (+) cable on discharged battery
 2. Positive (+) cable on booster battery
 3. Negative (-) cable on the booster battery
 4. Negative (-) cable on the engine block
 5. Booster battery
 6. Discharged battery
 7. Ground stud
4. Connect the other end of the positive cable to the positive terminal of the booster battery.
 5. Connect the black negative (-) cable to the other terminal (negative) of the booster battery.
 6. MAKE THE FINAL CONNECTION ON THE GROUND STUD, LOCATED ON THE RIGHT SIDE REAR BRACKET OF THE ENGINE DECK, OF THE STALLED VEHICLE (NOT TO THE NEGATIVE POST) AWAY FROM THE BATTERY. STAND BACK (see Figure 11).

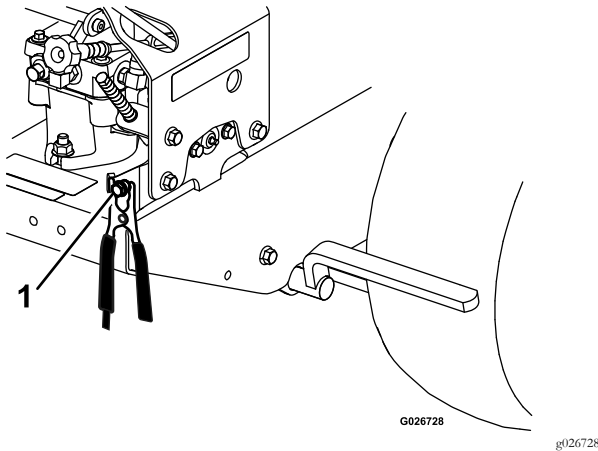

Figure 11

7. Start the vehicle and remove the cables in the reverse order of connection (the engine block (black) connection is the first to disconnect).

Check Mower Blades

Service Interval: Before each use or daily

1. Stop engine, wait for all moving parts to stop, and remove key. Engage parking brake.
2. Lift deck and secure in raised position as stated in the **Clean Grass Build-Up Under Deck** procedure in the deck Operator's manual.
3. Inspect blades and sharpen or replace as required.
4. Reinstall blades (if they were removed) in the following order:

- A. Install bushing through blade with bushing flange on bottom (grass) side of blade.

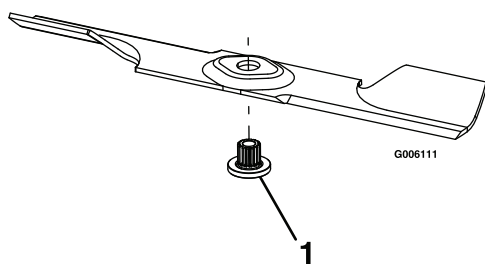

Figure 12

1. Install bushing in blade prior to installing bushing in spindle.

- B. Install bushing/blade combo into spindle.

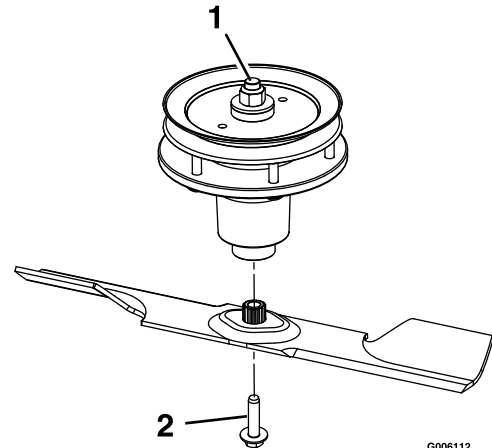

Figure 13

1. Use wrench here for blade installation. This nut has been torqued to 90–110 ft-lb (122–149 N-m)
2. Torque to 55-60 ft-lb (75-81 N-m) Apply lubricant to threads as needed to prevent seizing. Copper-based anti-seize preferable. Grease acceptable substitute.

- C. Apply lubricant to threads of blade bolt as needed to prevent seizing. Copper-based anti-seize preferable. Grease acceptable substitute. Install blade bolt finger tight. Place wrench on the top spindle nut then torque the blade bolts to 55-60 ft-lb (75-81 N-m).

⚠ WARNING

Incorrect installation of the blade or components used to retain the blade can be dangerous. Failure to use all original components and assembled as shown could allow a blade or blade component to be thrown out from under the deck resulting in serious personal injury or death.

Always install the original Exmark blades, blade bushings, and blade bolts as shown.

Check Safety Interlock System



Service Interval: Before each use or daily

Maintenance

Important: It is essential that operator safety mechanisms be connected and in proper operating condition prior to use.



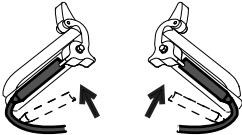



Note: If machine does not pass any of these tests, **Do Not** operate. Contact an Authorized Service Dealer.

Check the Normal Engine Starting Chart

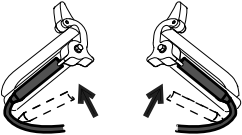

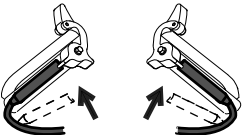

	System			
	PTO	OPC Levers	Speed Control Levers	Outcome
State of System	Disengaged (Blades) 	Both levers depressed (engaged) 	In Neutral N	Starter should crank 





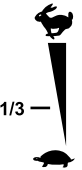

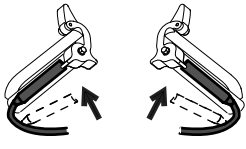

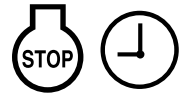

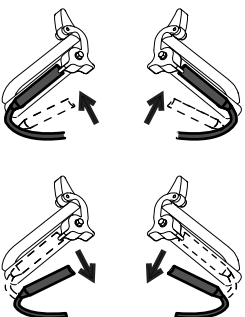

Check Engine Starting Circuit Chart

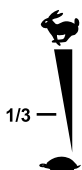
Note: In the **Check Engine Starting Circuit Chart**, the state of system item that is bold is being checked in each scenario.

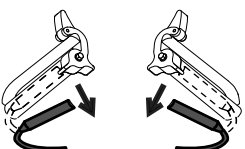
	System			
	PTO	OPC Levers	Speed Control Levers	Outcome
State of System	Disengaged (Blades) 	Both levers depressed (engaged) 	Any speed except neutral 	Starter must not crank 
	Engaged (Blades) 	Both levers depressed (engaged) 	In Neutral N	Starter must not crank 

Check Shutdown Circuit Chart

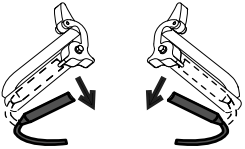
	System					Outcome
	Engine	Parking Brake	PTO	OPC Levers	Speed Control Levers	
State of System	Running idle (1/3 throttle) 	Engaged 	Disengaged (Blades) 	Both levers depressed (engaged) 	Any speed except neutral 	Engine must begin shutdown within 1 second 00:00:01 

	System				Outcome
	Engine	PTO	OPC Levers	Speed Control Levers	
State of System	Running idle (1/3 throttle) 	Disengaged (Blades) 	Both levers depressed (engaged) or released (disengaged) 	Any speed except neutral 	Engine must begin shutdown within 1 second 00:00:01 
	Running idle (1/3 throttle) 	Engaged (Blades) 	Both levers released (disengaged) 	In Neutral N	Engine must begin shutdown within 1 second 00:00:01 
	Running idle (1/3 throttle) 	Engaged (Blades) 	Both levers released (disengaged) 	Any speed except neutral 	PTO must begin shutdown within 1 second; engine stays running. 00:00:01 

Maintenance

Check for Loose Hardware

Service Interval: Before each use or daily

1. Stop engine, wait for all moving parts to stop, and remove key. Engage parking brake.
2. Visually inspect machine for any loose hardware or any other possible problem. Tighten hardware or correct the problem before operating.

Service Air Cleaner

Service Interval: Every 250 hours—Replace the primary air cleaner element — check secondary air cleaner element; replace if dirty. (May need more often under severe conditions. See the Engine manual for additional information.)

Every 500 hours—Replace the secondary air cleaner element. (May need more often under severe conditions. See the Engine manual for additional information.)

1. Stop engine, wait for all moving parts to stop, and remove key. Engage parking brake.
2. See the Engine Owner's Manual for maintenance instructions.

Change Engine Oil

Service Interval: After the first 5 hours

Every 100 hours (May need more often under severe conditions.)

1. Stop engine, wait for all moving parts to stop, and remove key. Engage parking brake.
2. Drain oil while engine is warm from operation.
3. The oil drain hose is located on right hand side of engine for Kohler or left hand side for Kawasaki. Place pan under machine to catch oil. Remove plug from end of drain hose. Allow oil to drain and replace oil drain plug. Torque plug to 20-24 ft-lb.
4. Replace the oil filter every other oil change. Clean around oil filter and unscrew filter to remove.

Before reinstalling new filter, apply a thin coating of Exmark 4-Cycle Premium Engine Oil on the surface of the rubber seal. Turn filter clockwise until rubber seal contacts the filter adapter then tighten filter an additional 1/2 to 3/4 turn.

5. Clean around oil fill cap and remove cap. Fill to specified capacity and replace cap.
6. Use oil recommended in the **Check Engine Oil Level** section. **Do Not** overfill. Start the engine and check for leaks. Stop engine and recheck oil level.

Check Hydraulic Oil Level

Service Interval: Every 40 hours

1. Stop engine and wait for all moving parts to stop, and remove key. Engage parking brake.
2. Clean area around hydraulic reservoir cap and remove cap. Oil level should be to the top of the baffle inside the tank. If not, add oil. Use Exmark Premium Hydro Oil. Replace hydraulic reservoir cap and tighten until snug. Do Not overtighten.

Note: The baffle is labeled “HOT” and “COLD”. The oil level varies with the temperature of the oil. The “HOT” level shows the level of oil when it is at 225°F (107°C). The “COLD” level shows the level of the oil when it is at 75°F (24°C). Fill to the appropriate level depending upon the temperature of the oil. For example: If the oil is about 150°F (65°C), fill to halfway between the “HOT” and “COLD” levels. If the oil is at room temperature (about 75°F (24°C)), fill only to the “COLD” level.

Check Tire Pressures

Service Interval: Every 40 hours

1. Stop engine, wait for all moving parts to stop, and remove key. Engage parking brake.
 2. Check tire pressure in drive tires.
 3. Inflate drive tires to 12–14 psi (83–97 kPa).
 4. Inflate tires to pressures stated above. Measure the circumference of each drive tire. Adjust tire pressures within the above range to try to make tire circumferences match as closely as possible.
- Semi-pneumatic caster tires do not need to be inflated.

Note: Do Not add any type of tire liner or foam fill material to the tires. Excessive loads created by foam filled tires may cause failures to the hydro drive system, frame, and other components. Foam filling tires will void the warranty.

Check Condition Of Belts

Service Interval: Every 40 hours

1. Stop engine, wait for all moving parts to stop, and remove key. Engage parking brake.
2. Remove the three mower deck belt shields to check mower primary and secondary belt condition.
3. Look under engine deck to check the pump drive belt condition.
4. Check all idler arms to be sure they pivot freely.

Lubricate Grease Fittings

Note: See chart for service intervals.

1. Stop engine, wait for all moving parts to stop, and remove key. Engage parking brake.
2. Lubricate fittings with one to two pumps of NLGI grade #2 multi-purpose gun grease.

Refer to the following chart for fitting locations and lubrication schedule.

Lubrication Chart			
Fitting Locations	Initial Pumps	Number of Places	Service Interval
1. Front Caster Wheel Hubs	*0	2	*Yearly
2. Front Caster Pivots	*0	2	*Yearly
3. Idler Pivots (Mower Deck)	1	1	Yearly
4. Hydro Control Arm Support Bushings	2	2	40 Hours

* See step 3 for special lubrication instructions on the front caster pivots and the **Lubricate Caster Wheel Hubs** section for special lubrication instructions on the front casters wheel hubs.

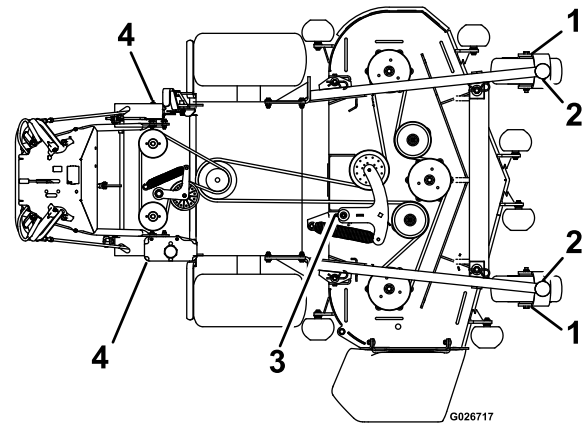

3. Lubricate front caster pivots once a year. Remove hex plug and cap. Thread grease zerk in hole and pump with grease until it oozes out around top bearing. Remove grease zerk and thread plug back in. Place cap back on.

Lubricate Caster Wheel Hubs

Service Interval: Yearly

1. Stop engine, wait for all moving parts to stop, and remove key. Engage parking brake.

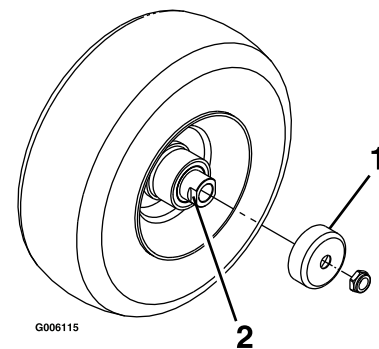

Figure 14

1. Seal guard
 2. Spacer nut with wrench flats
2. Remove caster wheel from caster forks.
 3. Remove seal guards from the wheel hub.
 4. Remove one of the spacer nuts from the axle assembly in the caster wheel. Note that thread locking adhesive has been applied to lock the

Maintenance

spacer nuts to the axle. Remove the axle (with the other spacer nut still assembled to it) from the wheel assembly.

5. Pry out seals, and inspect bearings for wear or damage and replace if necessary.
6. Pack the bearings with a NLGI grade #1 multi-purpose grease.
7. Insert one bearing, one new seal into the wheel.
Note: Seals (Exmark P/N 103-0063) must be replaced.
8. If the axle assembly has had both spacer nuts removed (or broken loose), apply a thread locking adhesive to one spacer nut and thread onto the axle with the wrench flats facing outward. Do Not thread spacer nut all of the way onto the end of the axle. Leave approximately 1/8 inch (3 mm) from the outer surface of the spacer nut to the end of the axle inside the nut.
9. Insert the assembled nut and axle into the wheel on the side of the wheel with the new seal and bearing.
10. With the open end of the wheel facing up, fill the area inside the wheel around the axle full of NLGI grade #1 multi-purpose grease.
11. Insert the second bearing and new seal into the wheel.
12. Apply a thread locking adhesive to the 2nd spacer nut and thread onto the axle with the wrench flats facing outward.
13. Torque the nut to 75-80 in-lb (8-9 N-m), loosen, then re-torque to 20-25 in-lb (2-3 N-m). Make sure axle does not extend beyond either nut.
14. Reinstall the seal guards over the wheel hub and insert wheel into caster fork. Reinstall caster bolt and tighten nut fully.

Important: To prevent seal and bearing damage, check the bearing adjustment often. Spin the caster tire. The tire should not spin freely (more than 1 or 2 revolutions) or have any side play. If the wheel spins freely, adjust torque on spacer nut until there is a slight amount of drag. Reapply thread locking adhesive.

Remove Engine Shrouds and Clean Cooling Fins

Service Interval: Every 80 hours

1. Stop engine, wait for all moving parts to stop, and remove key. Engage parking brake.
2. Remove cooling shrouds from engine and clean cooling fins. Also clean dust, dirt, and oil from external surfaces of engine which can cause improper cooling.
3. Make sure cooling shrouds are properly reinstalled. Operating the engine without cooling shrouds will cause engine damage due to overheating.

Check Spark Plugs

Service Interval: Every 160 hours

Remove spark plugs, check condition and reset gaps, or replace with new plugs. See Engine Owner's Manual.

Change Fuel Filter

Service Interval: As required

A fuel filter is installed between the fuel tank and the engine. Replace when necessary.

For Kohler EFI Units:

⚠ WARNING

Fuel system components are under high pressure. The use of improper components can result in system failure, gasoline leakage and possible explosion.

Use only approved fuel lines and fuel filters for high pressure systems.

Replacement Filters	
Kawasaki	Kawasaki P/N 49019-0014
Kohler EFI	Kohler P/N 24 050 13

Note: It is important to reinstall the fuel line hoses and secure with plastic ties the same as they were originally installed at the factory to keep the fuel line away from components that could cause fuel line damage.

Change Hydraulic System Filter and Fluid

Service Interval: After the first 250 hours

Every 500 hours/Yearly (whichever comes first) thereafter (Every 250 hours/Yearly if using Mobil 1 15W50 thereafter)

Note: Use only Exmark Part No. 109-4180 for Summer use above 32°F (0°C) or P/N 1-523541 for Winter use below 32°F (0°C) (Refer to **Transmission** section in Specifications for filter specifications).

1. Stop engine, wait for all moving parts to stop, and remove key. Engage parking brake.
2. Carefully clean area around filter. It is important that no dirt or contamination enter hydraulic system.
3. Place a catch pan under the hydro.
4. Unscrew filter to remove and allow oil to drain from reservoir.

Important: Before reinstalling new filter, fill it with Exmark Premium Hydro oil and apply a thin coat of oil on the surface of the rubber seal.

Turn filter clockwise until rubber seal contacts the filter adapter, then tighten the filter an additional 2/3 to 3/4 turn.

5. Fill reservoir as stated in **Check Hydraulic Oil Level**.

Exmark Premium Hydro Oil is recommended. Refer to the chart for an acceptable alternative:

Hydro Oil	Service Interval
Exmark Premium Hydro Oil (Preferred)	After first 250 hours *Every 500 hours/Yearly thereafter
Mobil 1 15W50	After first 250 hours *Every 250 hours/Yearly thereafter

*May need more often under sever conditions.

6. Loosen filter 1/2 turn and allow a small amount of oil to leak from the oil filter (this allows air to be purged from the oil filter and supply hose from the hydraulic reservoir). Turn filter clockwise until rubber seal contacts the filter adapter. Then tighten the filter an additional 2/3 to 3/4 turn.
7. Remove the catch pan and properly dispose of hydro oil and filter according to local codes.

8. Raise the rear of machine up and support with jack stands (or equivalent support) just high enough to allow drive wheels to turn freely.

▲ CAUTION

Raising the mower for service or maintenance relying solely on mechanical or hydraulic jacks could be dangerous. The mechanical or hydraulic jacks may not be enough support or may malfunction allowing the unit to fall, which could cause injury.

Do Not rely solely on mechanical or hydraulic jacks for support. Use adequate jack stands or equivalent support.

9. Start engine and move throttle control ahead to full throttle position. Move the speed control levers to the full speed and run for one minute. Shut down the machine, allow the hydros to cool and recheck oil level.

If either drive wheel does not rotate, one or both of the charge pumps (located on the top of the main pump as shown in Figure 15) may have lost their “prime”. Refer to **Hydraulic System Air Purge** section.

10. Remove the jack stands.

Note: Do Not change hydraulic system oil (except for what can be drained when changing filter), unless it is felt the oil has been contaminated or been extremely hot.

Changing oil unnecessarily could damage hydraulic system by introducing contaminates into the system.

Hydraulic System Air Purge

Service Interval: As required

Air must be purged from the hydraulic system when any hydraulic components, including oil filter, are removed or any of the hydraulic lines are disconnected.

The critical area for purging air from the hydraulic system is between the oil reservoir and each charge pump located on the top of each variable displacement pump (Figure 15). Air in other parts of the hydraulic system will be purged through normal operation once the charge pump is “primed”.

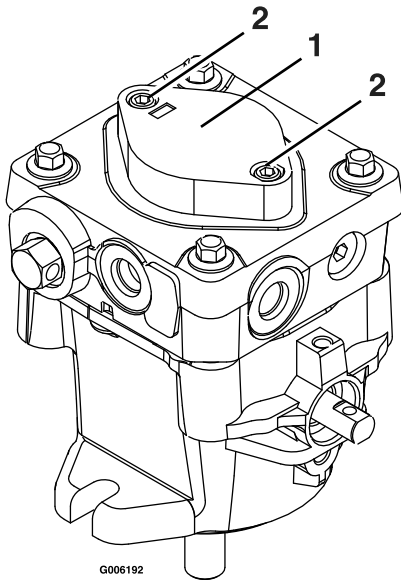

Figure 15

1. Charge pump cap 2. Loosen 1 1/2 turns only

1. Stop engine and wait for all moving parts to stop. Raise the rear of the machine up onto jack stands high enough to raise the drive wheels off the ground.
2. Check oil level as stated in **Check Hydraulic Oil Level** section.
3. Start engine and move throttle control ahead to full throttle position. Move the speed control lever to the middle speed position and place the drive levers in the “drive” position.

If either drive wheel does not rotate, it is possible to assist the purging of the charge pump by carefully rotating the tire in the forward position.

Note: It is necessary to lightly touch the charge pump cap with your hand to check the pump temperature. If the cap is too hot to touch, turn off engine. The pumps may be damaged if the pump becomes too hot.

If either drive wheel still does not rotate continue with step 4.

4. Thoroughly clean the area around each of the charge pump housings.
5. **Make sure engine is not running.** To “prime” charge pump, loosen two hex socket head capscrews (shown in Figure 15) **1 1/2 turns only**. Lift the charge pump housing upward and wait for a steady flow of oil to flow out from under

the housing. Retighten the capscrews. Do this for both pumps.

Note: Hydraulic reservoir can be pressurized up to 5 psi to speed this process.

6. If either drive wheel still does not rotate, stop and repeat steps 4 and 5 above for the respective pump. If wheels rotate slowly, the system may prime after additional running. Check oil level as stated in **Check the Hydraulic Oil Level** section.
7. Allow unit to run several minutes after the charge pumps are “primed” with drive system in the full speed position. Check oil level as stated in **Check the Hydraulic Oil Level** section.
8. Check hydro drive linkage adjustment as stated in **Hydro Drive Linkage Adjustment** section in Adjustments.

Thread Locking Adhesives

Thread locking adhesives such as “Loctite 242” or “Fel-Pro, Pro-Lock Nut Type” are used on the following fasteners:

- Pump drive sheave set screws.
- Square head setscrews on Hydro pump control arms.
- Shoulder bolts in ends of speed control crank.
- OPC lever setscrews.
- Electric clutch retaining bolt.
- Pump drive idler pivot bolt.
- Thumb latch screw threads on handles.
- Caster wheel spacer nuts.
- Fuel tank bulkhead fitting nuts.

Adhesives such as “Loctite RC/609 or RC/680” or “Fel-Pro Pro-Lock Retaining I or Retaining II” are used on the following:

- OPC lever hubs and cross-shaft

Note: Care must be used not to bond the bearing, next to each OPC hub, to the cross-shaft which could cause binding of the OPC levers and erratic operation.

- Fuel tank studs, where studs are inserted into tank.

Mobil HTS Grease (Or Food-Grade Anti-seize)

Mobil HTS grease (or food-grade anti-seize) is used in the following locations:

- Between the cutter housing spindle and bearings.
- Between the cutter housing spindle and sheave.
- Under top cutter housing bearing guard.

Copper-Based Anti-seize

Copper-based anti-seize is used in the following locations:

On threads of Blade Bolts Serial Nos. 540,000 and Higher. See **Check Mower Blades** section for instructions.

Dielectric Grease

Dielectric grease is used on all blade type electrical connections to prevent corrosion and loss of contact. Dielectric grease should not be applied to sealed connectors.

Adjustments

Note: Disengage PTO, shut off engine, wait for all moving parts to stop, engage parking brake, and remove key before servicing, cleaning, or making any adjustments to the unit.

Deck Leveling

See **Adjusting the Cutting Height** section in Operation.

Pump Drive Belt Tension

Self-tensioning - No adjustment necessary.

Deck Belt Tension

Self-tensioning - No adjustment necessary.

Park Brake Adjustment

1. Shut off engine and wait for all moving parts to stop.
2. Disengage the park brake.
3. Remove the clevis pin from the park brake yoke. Turn the yoke on the linkage until there is 3/16 inch (4.8 mm) to 1/4 inch (6.4 mm) clearance between the park brake tire bars and the tires with the park brake disengaged. Re-install the clevis pin.

Hydro Drive Linkage Adjustment

- **Adjust Speed Control Linkage and Neutral Safety Switch:**
 1. Stop engine and wait for all moving parts to stop. Engage parking brake. Remove key or spark plug wire(s).
 2. Pull the speed control lever back to neutral. Check that the neutral safety switch actuating tab has depressed the plunger of the switch so that there is no more than 3/16–1/4 inch (4.8–6.4 mm) between the tab and the switch (see Figure 16).

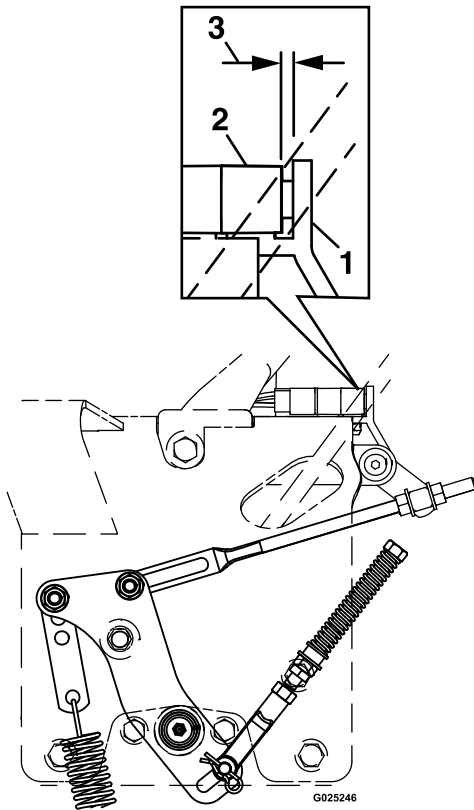

Figure 16

- | | |
|--------------------------|-------------------------------|
| 1. Actuating Tab | 3. 3/16–1/4 inch (4.8–6.4 mm) |
| 2. Neutral Safety Switch | |

If the wheel stops, then go to step 8. If the wheel turns while holding the drive lever in neutral, then neutral control linkages need to be adjusted; proceed with step 5.

- Loosen the nut against the neutral control linkage yoke as shown in Figure 17.

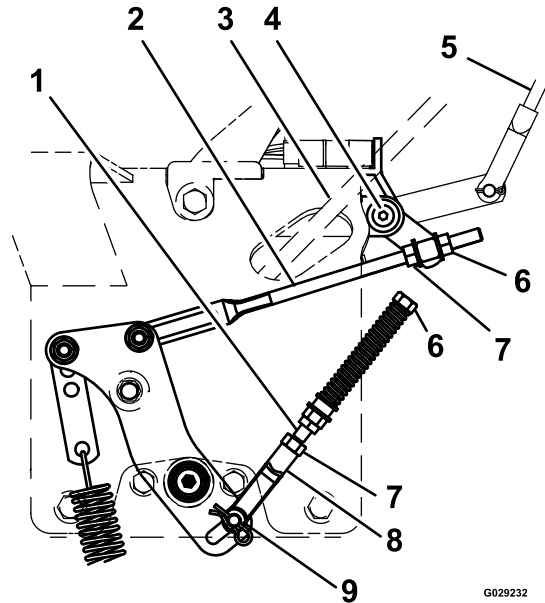

Figure 17

Viewed from Left Side of Unit

- | | |
|----------------------------|--|
| 1. Neutral Control Linkage | 6. Adjust here-rotate at approximately 1/4 turn increments and re-check. |
| 2. Hydro Control Linkage | 7. Loosen nut |
| 3. Drive Lever Linkage | 8. Yoke |
| 4. Speed Control Crank | 9. Pin is at the end of slot |
| 5. Speed Control Linkage | |

• Adjust Neutral Control Linkages:

- Raise the rear of the machine up onto jack stands high enough to raise the drive wheels off of the ground.
- Start the engine and move the throttle ahead to the full throttle position. Place the neutral lock latches in the “forward” position as shown in Figure 5. Release the park brake and move the speed control lever to the “mid-speed” position.

Note: The OPC levers must be held down and the park brake must be disengaged whenever the speed control lever is moved out of neutral or the engine will initiate shutdown.

- Squeeze the respective drive lever until an increased resistance is felt (pin is at the end of the slot), this is where neutral should be.
- Pull the drive lever(s) into reverse. Release the drive lever(s) until extra reverse spring resistance is gone (pin still at end of slot).

- Adjust the neutral control linkage until the respective drive wheel stops when the lever is pulled against the neutral spring (neutral position). Turn the adjusting bolt approximately 1/4 turn clockwise if the wheel is turning in reverse or turn the bolt approximately 1/4 turn counterclockwise if the wheel is turning forward. Release the drive lever to the forward drive position and squeeze back into the neutral position. Check to see if the wheel stops. If not, repeat the above adjustment procedure.
- Make this adjustment on both sides.
- After adjustments are made and the wheels stop when the drive levers are moved to the

neutral position from both the forward and reverse positions, tighten the nuts against the yokes.

• **Adjust Hydro Control Linkages:**

1. Place the speed control lever in the “neutral” position. This adjustment is again made with rear of machine on jack stands and engine running at full throttle. OPC levers will have to be held down and the park brake must be disengaged whenever speed control levers are moved out of the neutral position.

Note: The neutral lock latches should be “unlocked” and in the forward position.

2. Loosen the front nut on left hydro control linkage as shown in Figure 18. Turn the rear control linkage adjusting nut counterclockwise until wheel rotates forward. Turn the rear nut of left control linkage clockwise 1/4 of a turn at a time, stopping to move the speed control forward and back to neutral, until left wheel stops rotating forward.

Turn the rear nut an additional 1/2 turn and tighten the front nut making sure not to put a bind on the linkage. Make sure flat part of linkage is perpendicular to pin part of swivel (see Figure 18).

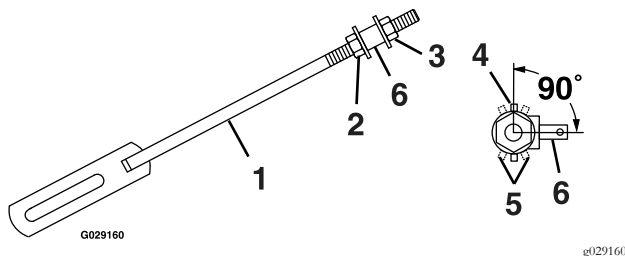

Figure 18

- | | |
|--|---|
| 1. Left Hydro Control Link (left side shown) | 4. Linkage is perpendicular to pin (correct position) |
| 2. Front nut | 5. Linkage in incorrect position |
| 3. Rear nut | 6. Swivel |

After adjusting the left hydro control linkage, move the speed control lever to the mid-speed position and then back to the neutral position. Recheck the left drive wheel rotation to see if further adjustment is necessary—be sure the speed control lever is in the neutral position.

Important: If inconsistent neutral occurs, check to be sure both springs are properly

tightened on the speed control lever under the console—especially the rear pivot spring. The gap between spring coils to be minimum 1/32 inch (.8 mm).

Repeat above adjustments if necessary.

3. Place the speed control lever in neutral. Adjust the right side linkage by turning the quick track knob counterclockwise until the tire begins to rotate forward. Begin to retighten the knob clockwise about 1/4 turn at a time, stopping to move the speed control forward and back to neutral. Recheck the drive wheel rotation to see if further adjustment is necessary.
4. The spring that keeps tension on the knob should normally not need adjustment. However, if adjustment is needed, adjust to where length of spring is about 1 inch (2.5 cm) between the washers. Adjust spring length by turning nut at front of spring.

• **Drive Lever Linkage Adjustment:**

1. With rear of machine still on jack stands and engine running at full throttle, disengage the park brake and move the speed control lever to the midway position. Move the respective drive lever upward/rearward until it reaches the neutral position and engage neutral lock latches (Figure 19). If the tire rotates in either direction, the length of the drive lever link will need to be adjusted.

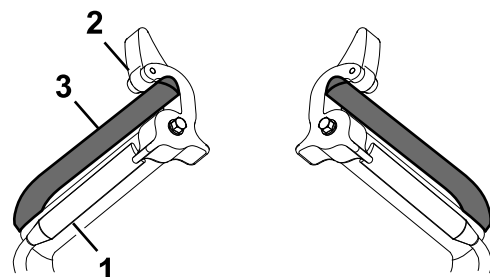

Figure 19

- | | |
|---|-------------------------|
| 1. OPC Lever | 3. Neutral lock latches |
| 2. Drive lever in neutral lock position | |

2. Adjust the linkage length by loosening the jam nuts at the top end of the linkage and rotating the linkage in the ball joints. Lengthen the linkage if the tire is turning in reverse and shorten the linkage if the tire is creeping forward. Tighten the jam nuts. Release and

Maintenance

re-engage the neutral lock latch checking that the tire stops. Continue this process until the tire is at a complete stop.

3. Pull the drive lever(s) into reverse. Release the drive lever(s) until extra reverse spring resistance is gone (pin still at end of slot). If the wheel stops, then go to step 8 of **Adjust Neutral Control Linkages** procedure. If the wheel turns while holding the drive lever in neutral, then neutral control linkages need to be adjusted (see step 5 in **Adjust Neutral Control Linkages** procedure).
4. Make this adjustment for both sides.
5. Stop engine and wait for all moving parts to stop. Raise rear of machine, remove jack stands, and carefully lower machine to the ground.

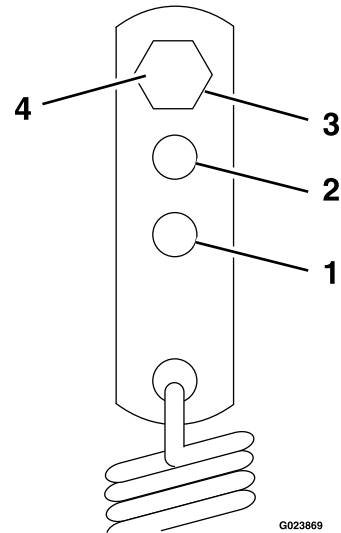

Figure 20

- | | |
|----------------|-------------------|
| 1. Heavy duty | 3. Standard |
| 2. Medium duty | 4. Retaining bolt |

Tracking Adjustment

1. Stop engine and wait for all moving parts to stop.
2. Check the drive tire pressures and tire circumferences as stated in **Check the Tire Pressures** section in Maintenance.
3. Run the unit and observe the tracking on a level, smooth, hard surface such as concrete or asphalt.
4. If the unit tracks to one side or the other, turn the quick track knob. Turn the knob right to “steer” right, turn the knob left to “steer” left.

Hydro Pump Spring Tension Setting

1. For medium or heavy duty drive conditions such as operation with a sulky on steep slopes, a higher spring force may be required on the hydro pump control arms to prevent the drive system from stalling.
2. For a heavier drive setting, relocate the spring anchor link as shown in Figure 20. The spring anchor links are located under the engine deck on the left and right hand sides.

Note: In “medium” or “heavy duty” positions, the drive lever forces at the upper handle will also be increased.

Electric Clutch Adjustment

No adjustment necessary.

Cleaning

Clean Engine and Exhaust System Area

Service Interval: Before each use or daily (May be required more often in dry or dirty conditions.)

⚠ CAUTION

Excessive debris around engine cooling air intake and exhaust system area can cause engine, exhaust area, and hydraulic system to overheat which can create a fire hazard.

Clean all debris from engine and exhaust system area.

1. Stop engine, wait for all moving parts to stop, and remove key. Engage parking brake.
2. Clean all debris from rotating engine air intake screen, around engine shrouding, and exhaust system area.
3. Wipe up any excessive grease or oil around the engine and exhaust system area

Remove Engine Shrouds and Clean Cooling Fins

Service Interval: Every 100 hours

1. Stop engine, wait for all moving parts to stop, and remove key. Engage parking brake.
2. Remove cooling shrouds from engine and clean cooling fins. Also clean dust, dirt, and oil from external surfaces of engine which can cause improper cooling.
3. Make sure cooling shrouds are properly reinstalled. Operating the engine without cooling shrouds will cause engine damage due to overheating.

Clean Debris From Machine

Service Interval: Before each use or daily

1. Stop engine, wait for all moving parts to stop, and remove key. Engage parking brake.
2. Clean off any oil, debris, or grass build-up on the machine and cutting deck, especially under deck

belt shields, around the fuel tank, around engine and exhaust area.

Clean Grass Build-Up Under Deck

Service Interval: Before each use or daily

1. Stop engine, wait for all moving parts to stop, and remove key. Engage parking brake.
2. Raise deck to the transport (maximum cutting height) position. Lift the front of unit and support unit using jack stands or equivalent support.

⚠ CAUTION

Raising the mower for service or maintenance relying solely on mechanical or hydraulic jacks could be dangerous. The mechanical or hydraulic jacks may not be enough support or may malfunction allowing the unit to fall, which could cause injury.

Do Not rely solely on mechanical or hydraulic jacks for support. Use adequate jack stands or equivalent support.

3. Clean out any grass build-up from underside of deck and in discharge chute.

Waste Disposal

Motor Oil Disposal

Engine oil and hydraulic oil are both pollutants to the environment. Dispose of used oil at a certified recycling center or according to your state and local regulations.

Battery Disposal

⚠ DANGER

Battery electrolyte contains sulfuric acid, which is poisonous and can cause severe burns. Swallowing electrolyte can be fatal or if it touches skin can cause severe burns.

- Wear safety glasses to shield eyes, and rubber gloves to protect skin and clothing when handling electrolyte.
- **Do Not** swallow electrolyte.
- **In the event of an accident, flush with water and call a doctor immediately.**

Maintenance

Federal law states that batteries should not be placed in the garbage. Management and disposal practices must be within relevant federal, state, or local laws.

If a battery is being replaced or if the unit containing the battery is no longer operating and is being scrapped, take the battery to a local certified recycling center. If no local recycling is available return the battery to any certified battery reseller.

Troubleshooting

Important: It is essential that all operator safety mechanisms be connected and in proper operating condition prior to mower use.

When a problem occurs, do not overlook the simple causes. For example: starting problems could be caused by an empty fuel tank.

The following table lists some of the common causes of trouble. Do Not attempt to service or replace major items or any items that call for special timing of adjustments procedures (such as valves, governor, etc.). Have this work done by your **Engine Service Dealer**.

Note: When disconnecting electrical connectors Do Not pull on the wires to separate the connectors.

Problem	Possible Cause	Corrective Action
Starter does not crank.	<ol style="list-style-type: none"> 1. PTO is engaged. 2. Speed control lever is are not in neutral lock position. 3. OPC levers are released. 4. Battery does not have a full charge. 5. Electrical connections are corroded, loose or faulty. 6. Fuse is blown. 7. Relay or switch is defective. 	<ol style="list-style-type: none"> 1. Disengage the PTO. 2. Ensure the speed control lever is in the neutral lock position. 3. Depress OPC levers. 4. Charge the battery. See Check Battery Charge and Recommended Jump Starting Procedure sections in Maintenance. 5. Check the electrical connections for good contact. Clean connector terminals thoroughly with electrical contact cleaner, apply dielectric grease and reconnect. 6. Replace the blown fuse. 7. Contact an Authorized Service Dealer.
Engine will not start, starts hard, or fails to keep running	<ol style="list-style-type: none"> 1. Fuel tank is empty. 2. Fuel shutoff valve is closed. 3. The throttle and choke are not in the correct position. 4. Dirt in fuel filter. 5. Dirt, water, or stale fuel is in the fuel system. 6. Air cleaner is dirty. 7. Electrical connections are corroded, loose or faulty. 8. Relay or switch is defective. 9. Faulty spark plug. 10. Spark plug wire is not connected. 11. MIL illuminates and blinks. 	<ol style="list-style-type: none"> 1. Fill the fuel tank. 2. Open the fuel shutoff valve. 3. Be sure the throttle control is midway between the "SLOW" and "FAST" positions, and the choke is in the "ON" position for a cold engine or the "OFF" position for a warm engine. 4. Replace the fuel filter. 5. Contact an Authorized Service Dealer. 6. Clean or replace the air cleaner element. 7. Check the electrical connections for good contact. Clean connector terminals thoroughly with electrical contact cleaner, apply dielectric grease and reconnect. 8. Contact an Authorized Service Dealer. 9. Clean, adjust or replace spark plug. 10. Check the spark plug wire connection. 11. Contact an Authorized Service Dealer.
Engine loses power	<ol style="list-style-type: none"> 1. Engine load is excessive 2. Air cleaner is dirty. 3. Oil level in the crankcase is low. 4. Cooling fins and air passages for the engine are plugged. 5. Vent hole in the fuel cap is plugged. 6. Dirt in fuel filter. 7. Dirt, water, or stale fuel is in the fuel system. 	<ol style="list-style-type: none"> 1. Reduce the ground speed. 2. Clean or replace the air cleaner element. 3. Add oil to the crankcase. 4. Remove the obstructions from the cooling fins and air passages. 5. Clean or replace the fuel cap. 6. Replace the fuel filter. 7. Contact an Authorized Service Dealer.

Troubleshooting

Problem	Possible Cause	Corrective Action
Engine overheats	<ol style="list-style-type: none"> 1. Engine load is excessive 2. Oil level in the crankcase is low. 3. Cooling fins and air passages for the engine are plugged. 	<ol style="list-style-type: none"> 1. Reduce the ground speed. 2. Add oil to the crankcase. 3. Remove the obstructions from the cooling fins and air passages.
Mower pulls left or right (with levers fully forward).	<ol style="list-style-type: none"> 1. Tracking needs adjustment. 2. Tire pressure in drive tires not correct. 	<ol style="list-style-type: none"> 1. Adjust the tracking by turning knob on the right hydro control linkage in the direction that the mower needs to be adjusted to. Turn the knob in 1/4 turn increments until the mower tracks correctly. 2. Adjust tire pressure in the drive tires.
Machine does not drive.	<ol style="list-style-type: none"> 1. Bypass valve is not closed tight. 2. Drive or pump belt is worn, loose or broken. 3. Drive or pump belt is off a pulley. 	<ol style="list-style-type: none"> 1. Tighten the bypass valve. 2. Change the belt. 3. Change the belt.
Uneven cutting height.	<ol style="list-style-type: none"> 1. Blade(s) not sharp. 2. Cutting blade(s) is/are bent. 3. Mower deck is not level. 4. Underside of mower is dirty. 5. Tire pressure in drive tires not correct. 6. Blade spindle bent. 7. Tips of adjacent blades are at an uneven cutting height. Blades tips should be even within 3/16 inch which is approximately one blade thickness. 	<ol style="list-style-type: none"> 1. Sharpen the blade(s). 2. Install new cutting blade(s). 3. Level mower deck from side-to-side and front-to-rear. 4. Clean the underside of the mower. 5. Adjust tire pressure in the drive tires. 6. Contact an Authorized Service Dealer. 7. Replace blades, spindles and (or) check for damage to mower deck.
Abnormal vibration	<ol style="list-style-type: none"> 1. Cutting blade(s) is/are bent or unbalanced. 2. Blade mounting bolt is loose. 3. Engine mounting bolts are loose. 4. Loose engine pulley, idler pulley, or blade pulley. 5. Engine pulley is damaged. 6. Blade spindle is bent. 7. Belt is damaged. 	<ol style="list-style-type: none"> 1. Install new cutting blade(s). 2. Tighten the blade mounting bolt. 3. Tighten the engine mounting bolts. 4. Tighten the appropriate pulley. 5. Contact an Authorized Service Dealer. 6. Contact an Authorized Service Dealer. 7. Install new belt.
Blades do not rotate.	<ol style="list-style-type: none"> 1. Drive belt is worn, loose or broken. 2. Drive belt is off pulley. 3. Deck belt is worn, loose or broken. 4. Deck belt is off pulley. 5. Broken or missing idler spring. 6. PTO clutch does not engage. 	<ol style="list-style-type: none"> 1. Check the belt tension. 2. Check belt for damage; replace if necessary. Install drive belt and check adjusting shafts and belt guides for correct position. 3. Install new deck belt. 4. Install deck pulley and check the idler pulley, idler arm and spring for correct position and function. 5. Replace the spring. 6. Contact an Authorized Service Dealer.

Schematics

Electrical Logic Schematic—Kawasaki

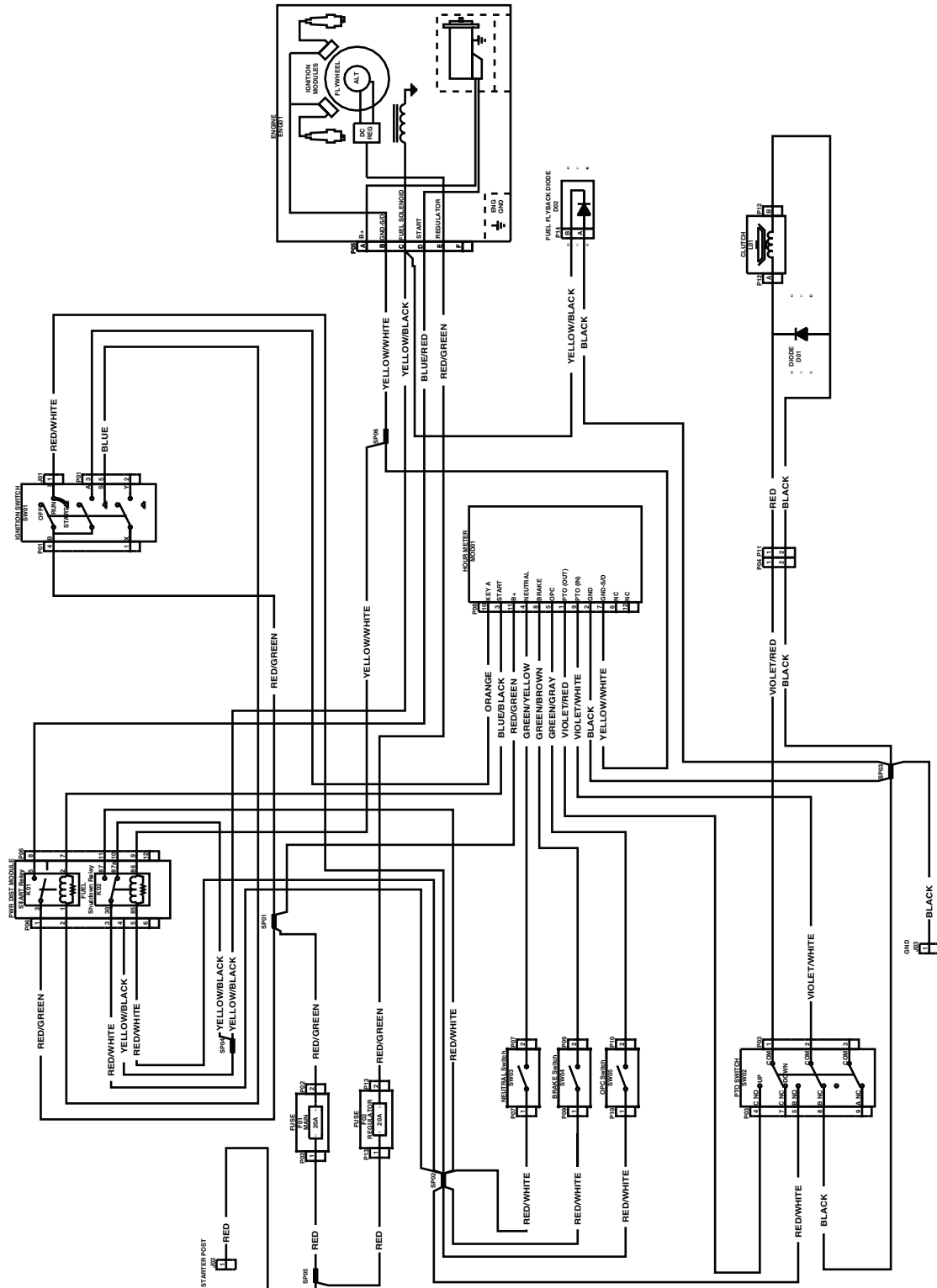

Electrical Logic Schematic—Kohler EFI

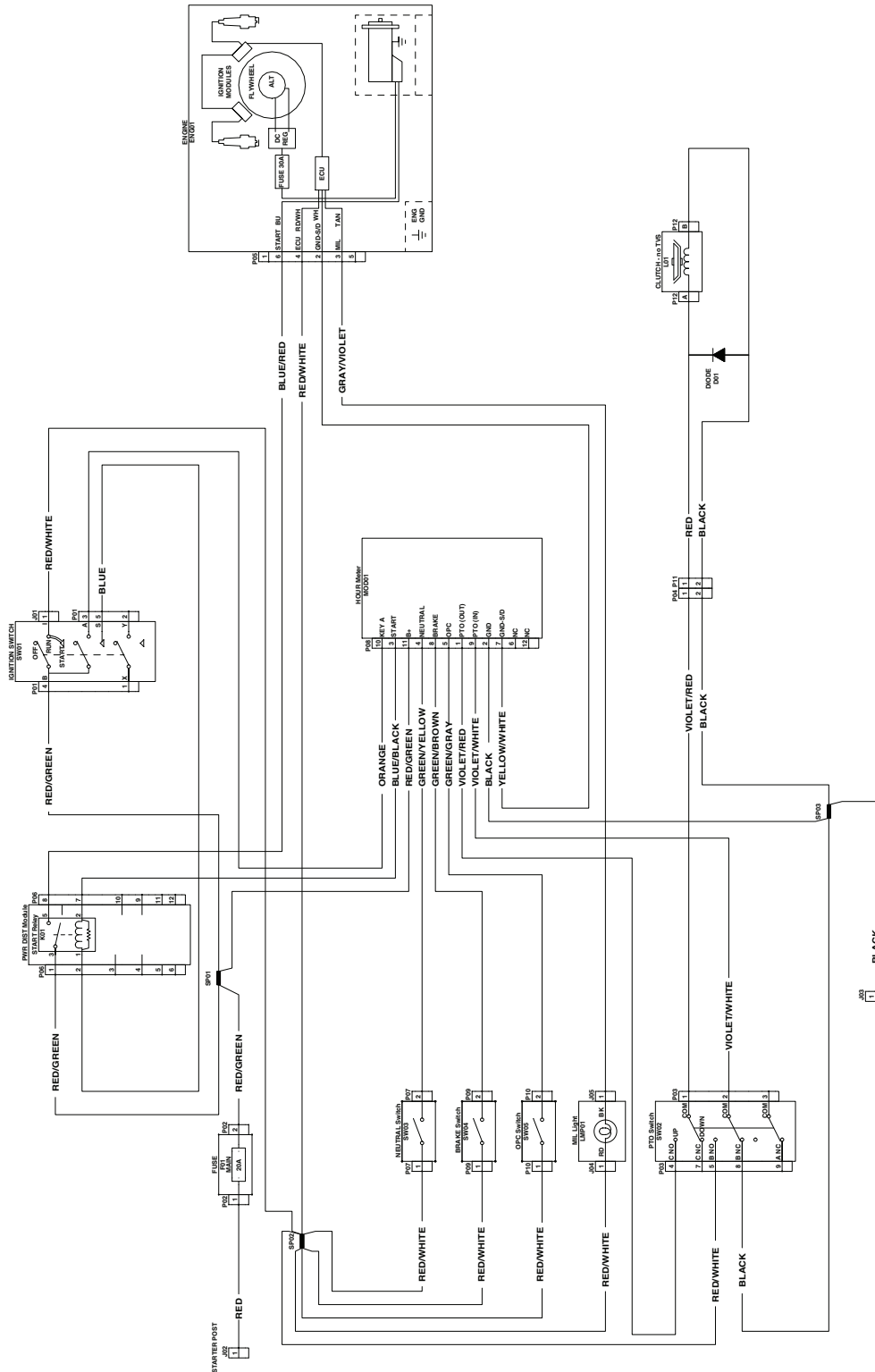

g228346

Hydraulic Diagram

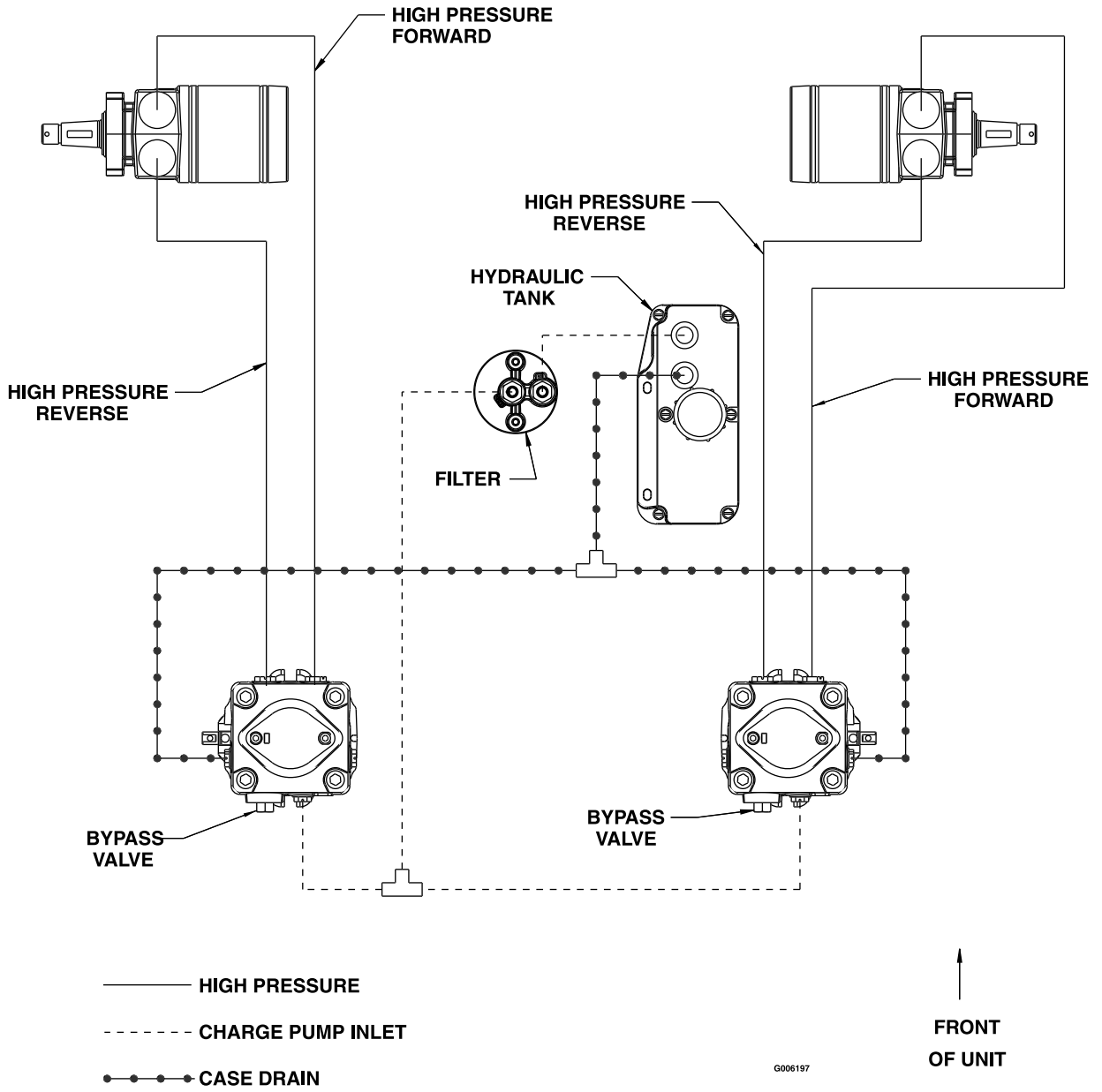

g006197

Notes:

Notes:



MAXIMIZE THE PERFORMANCE OF YOUR EXMARK MACHINE.



EXMARK® PREMIUM ENGINE OIL

Exmark now offers a family of engine oil viscosities to perform well in any environment. Each viscosity has the same synthetic formulation to give you what you need in punishing conditions. We designed each grade to the highest quality, making it ideal even for diesel applications. Coupled with Exmark Premium Fuel Treatment, we have the performance products to make your machine hum.

EXMARK PREMIUM ENGINE OIL SAE 30/10W-30

- Meets zero shear requirements of a straight grade SAE 30 as well as the cold temp properties of a 10W-30.
- Most versatile oil in the industry.
- Superior corrosion protection over conventional oil - even in corrosive, humid environments.

EXMARK PREMIUM ENGINE OIL SAE 20W-50

- Perfect for your big block engine, or any application in severe service.
- Same full synthetic formulation as all other Exmark Premium viscosities.
- Also effective for use in severe service small block engines.

EXMARK PREMIUM ENGINE OIL SAE 10W-50

- Full synthetic formulation gives you peak performance. Don't settle for less.
- Wide span multi-grade combines easy starting in cold weather with maximum protection in high temperature operation.
- Reduce friction & wear over standard mineral formulations.

EXMARK PREMIUM ENGINE OIL SAE 0W-40

- The perfect choice for when the weather turns cold or unpredictable, and your Exmark UTV has to perform.
- Commercial quality for severe service.
- Advanced additive package helps prevent corrosion from long-term storage.

EXMARK PREMIUM ENGINE OIL UTV FORMULATION

- 4-cycle high-temp formulation.
- Heavier viscosity, full synthetic, perfect for your UTV.

EXMARK PREMIUM UTV EXTREME CONDITIONS GEAR OIL

- SAE 80W-90, designed to keep your UTV performing at its peak.
- Shear stable, hypoid gear lube.
- Includes a premium additive system to combat wear, oxidation, rust & corrosion.

Available from your local Exmark dealer. Find your closest dealer at exmark.com

EXMARK ACCESSORIES AND OPTIONS*

MID-MOUNT RIDING ACCESSORIES AND OPTIONS

CUSTOM RIDE SEAT SUSPENSION SYSTEM	OPERATOR CONTROLLED DISCHARGE
FULL SUSPENSION SEAT	SUN SHADE
DECK LIFT ASSIST KIT	TRASH CONTAINER
HITCH KIT	TURF STRIPER
LIGHT KIT	ULTRA VAC COLLECTION SYSTEM
12V POWER PORT	ULTRA VAC QUICK DISPOSAL SYSTEM
MICRO-MULCH SYSTEM	

OUT-FRONT RIDING ACCESSORIES AND OPTIONS

CUSTOM RIDE SEAT SUSPENSION SYSTEM	SNOW BLADE
DUAL-TAIL WHEEL	SNOWBLOWER
FLOOR PAN EXTENDER	SUN SHADE
HITCH KIT	TRASH CONTAINER
LIGHT KIT	ULTRA VAC COLLECTION SYSTEM
MICRO-MULCH SYSTEM	ULTRA VAC QUICK DISPOSAL SYSTEM
ROLL OVER PROTECTION SYSTEM (ROPS)	WEATHER CAB

WALK-BEHIND ACCESSORIES AND OPTIONS

GRASS CATCHER	TURF STRIPER
MICRO-MULCH SYSTEM	STANDON

*Some accessories and options not available for some models.

Place Model No. and Serial No.
Label Here (Included in the Literature
Pack) or Fill in Below

Model No. _____

Serial No. _____

Date Purchased _____

Engine Model No. and Spec. No. _____

Engine Serial No. (E/No) _____

©2017 Exmark Mfg. Co., Inc.
Industrial Park Box 808
Beatrice, NE 68310
All Rights Reserved

Part No. 4503-848 Rev. A
(402) 223-6375
Fax (402) 223-5489
Printed in the USA

