



CCR™ 2400 GTS®

CCR™ 3000 GTS®

Snowthrower

Model No. 38412-9900001 & Up

Model No. 38418-9900001 & Up

Model No. 38433-9900001 & Up

Model No. 38438-9900001 & Up

Operator's Manual

Figures

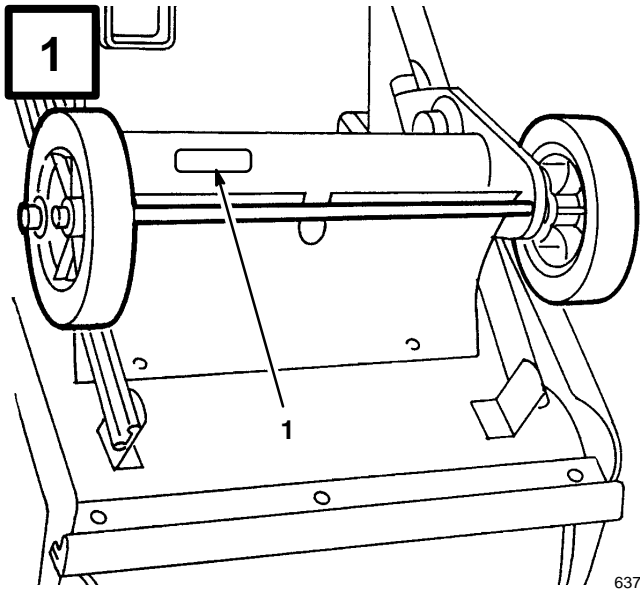

1. Model and serial number decal

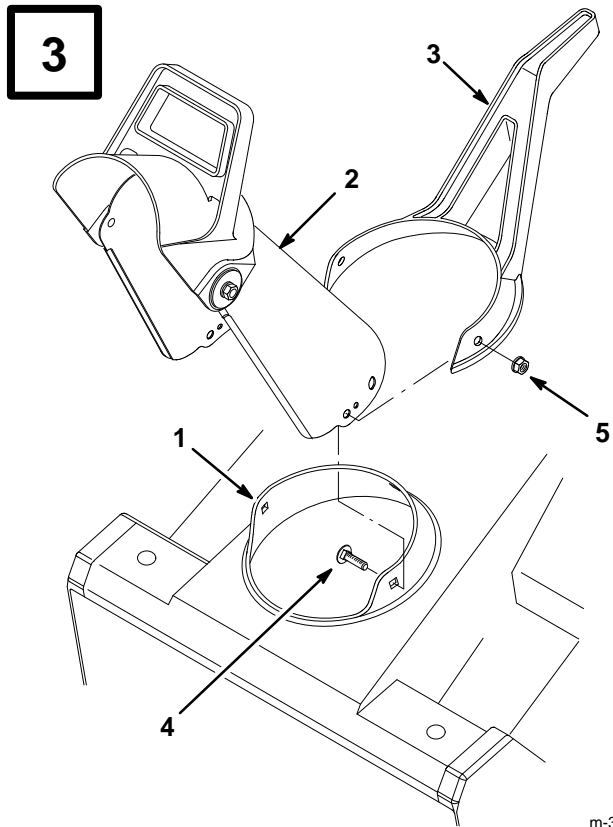

Models 38412 & 38418

- 1. Chute ring
- 2. Discharge chute
- 3. Chute handle
- 4. Carriage bolt
- 5. Lock nut

m-3277

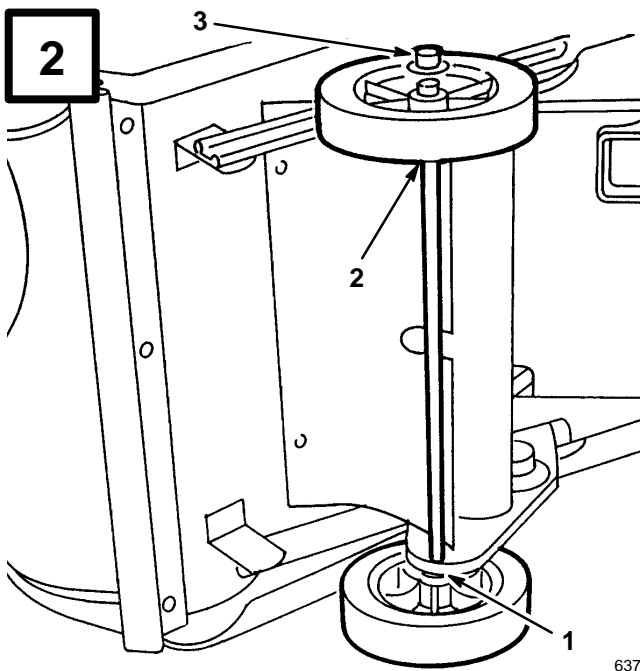

(Unit shown on right side)

- 1. Short spacer
- 2. Long spacer
- 3. Pushnut

637

4

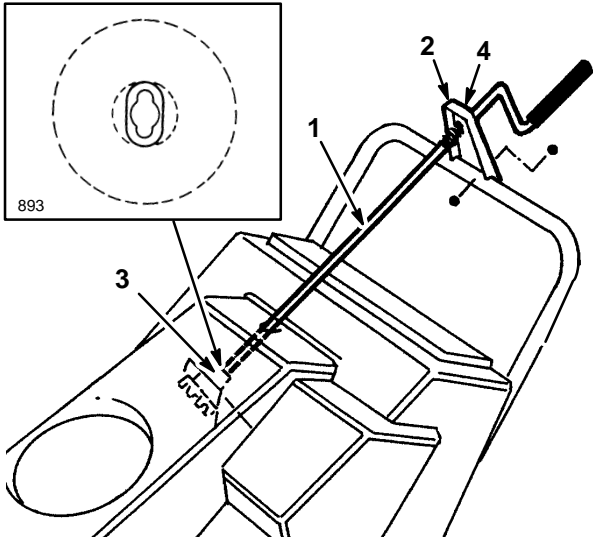

Models 38433 & 38438

- 1. Chute crank
- 2. Mounting bracket
- 3. Gear
- 4. Plastic bushing

635

5

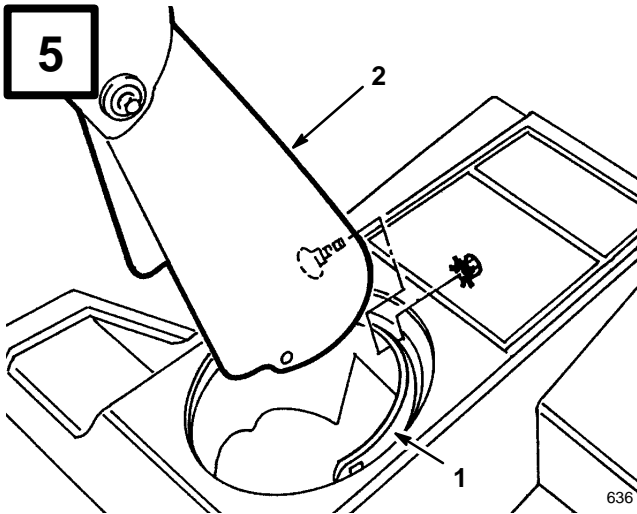

Models 38433 & 38438

- 1. Chute ring
- 2. Discharge chute

636

6

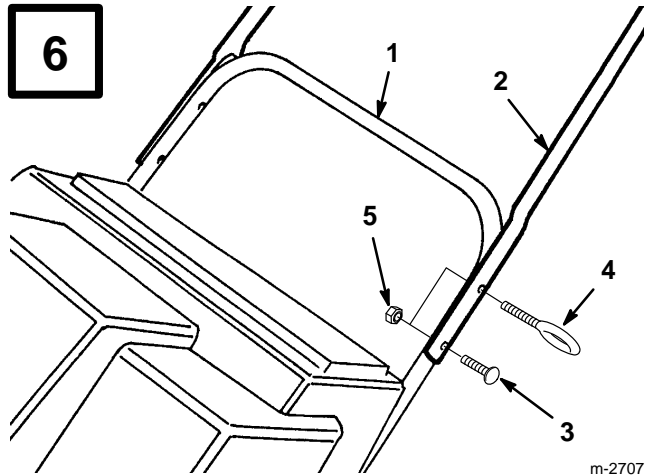

m-2707

Models 38412 & 38418

- 1. Lower handle
- 2. Upper handle
- 3. Handle bolt
- 4. Eyebolt
- 5. Lock nut

7

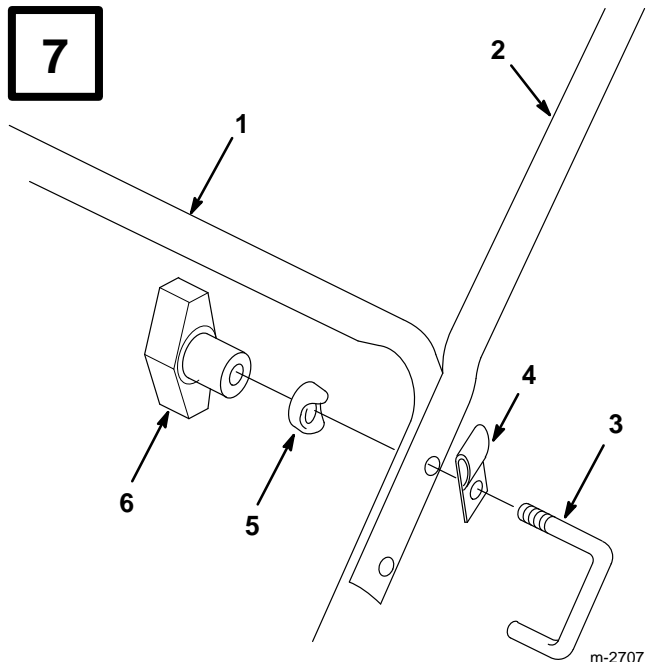

m-2707

Models 38433 & 38438

- 1. Lower handle
- 2. Upper handle
- 3. Handle lock
- 4. Cable guide
- 5. Curved washer
- 6. Knob

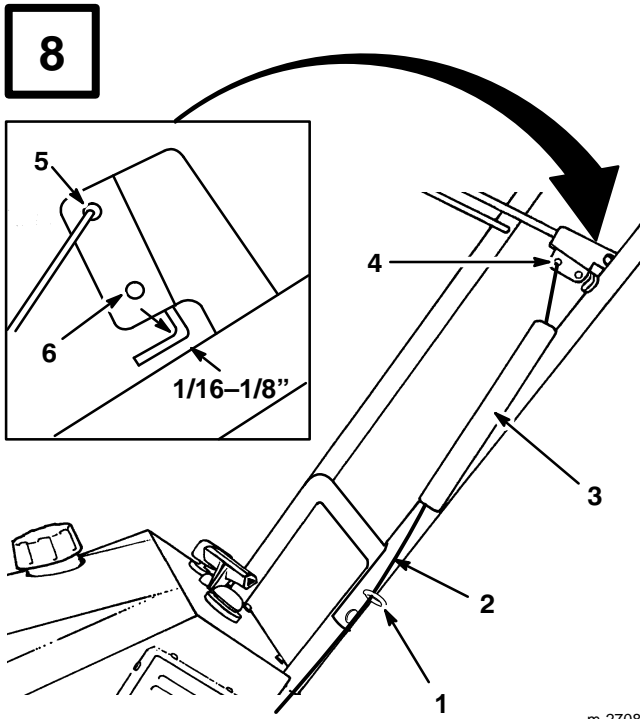

Models 38412 & 38418

- | | |
|------------------|------------------------|
| 1. Eyebolt | 4. Control bar bracket |
| 2. Control cable | 5. Top hole |
| 3. Spring cover | 6. Bottom hole |

m-2708

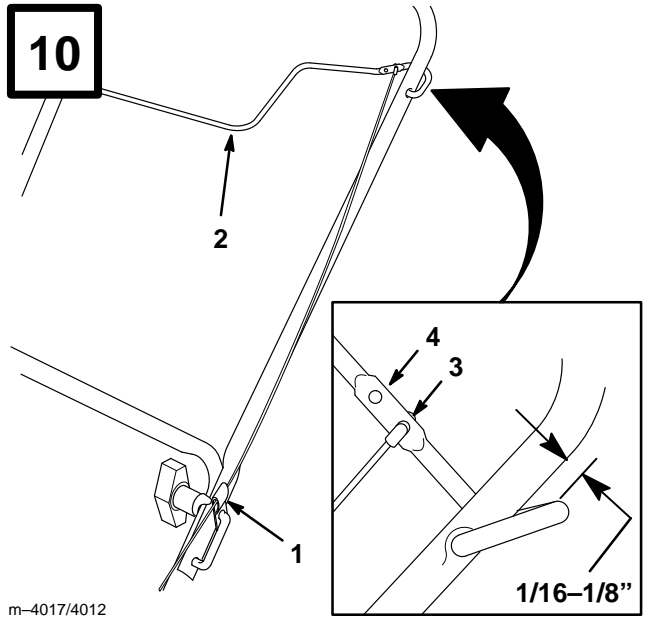

m-4017/4012

Models 38433 & 38438

- | | |
|------------------------|-----------------|
| 1. Cable guide | 3. Rear hole |
| 2. Control bar bracket | 4. Forward hole |

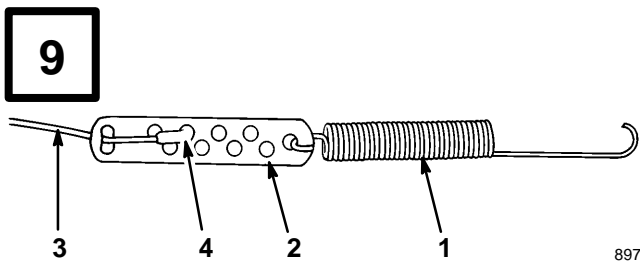

Models 38412 & 38418

- | | |
|-------------------|--------------|
| 1. Spring | 3. Cable |
| 2. Cable adjuster | 4. Z fitting |

897

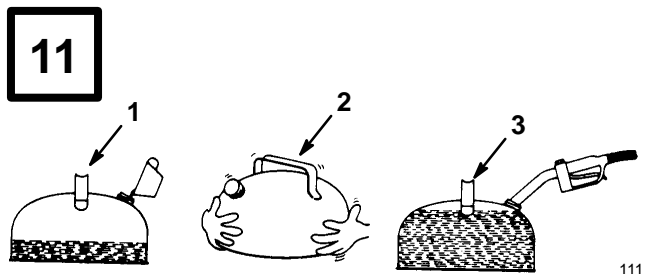

111

1. Add oil to small amount of gasoline
2. Install cap and shake can to mix
3. Add remaining amount of gasoline

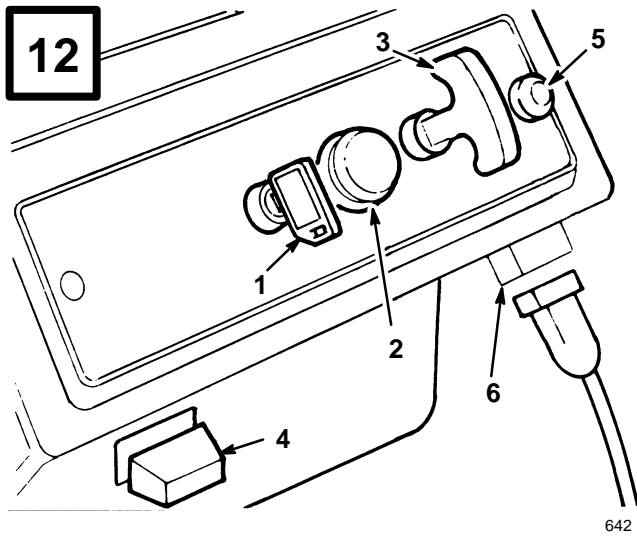

642

- 1. Key switch
- 2. Primer
- 3. Recoil start
- 4. Choke
- 5. Elec. start button*
- 6. Cord connection*

* ELEC. START MODEL

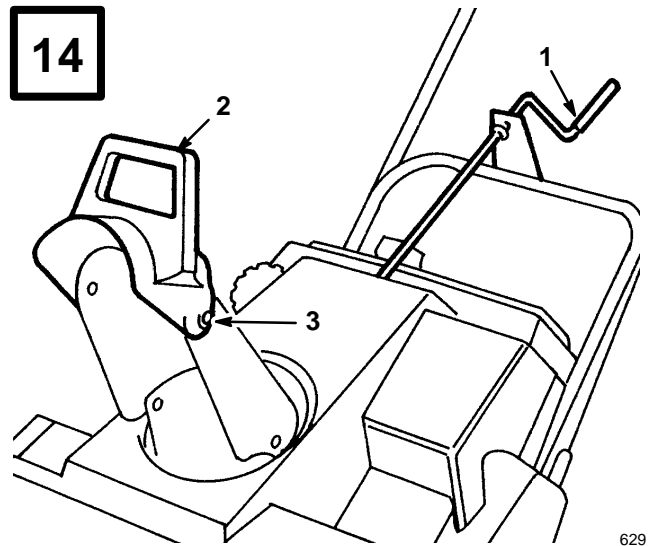

629

Models 38433 & 38438

- 1. Chute crank
- 2. Chute deflector handle
- 3. Deflector mounting nuts

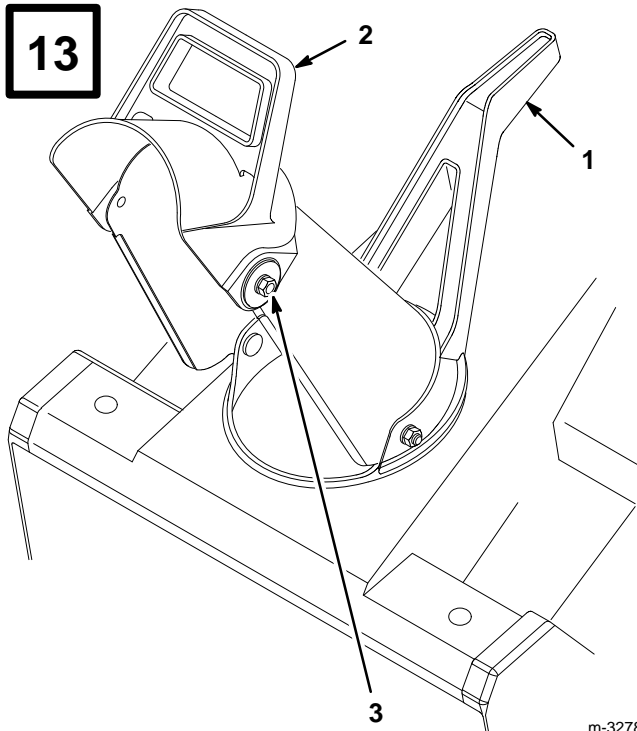

m-3278

Models 38412 & 38418

- 1. Chute handle
- 2. Chute deflector handle
- 3. Deflector mounting nuts

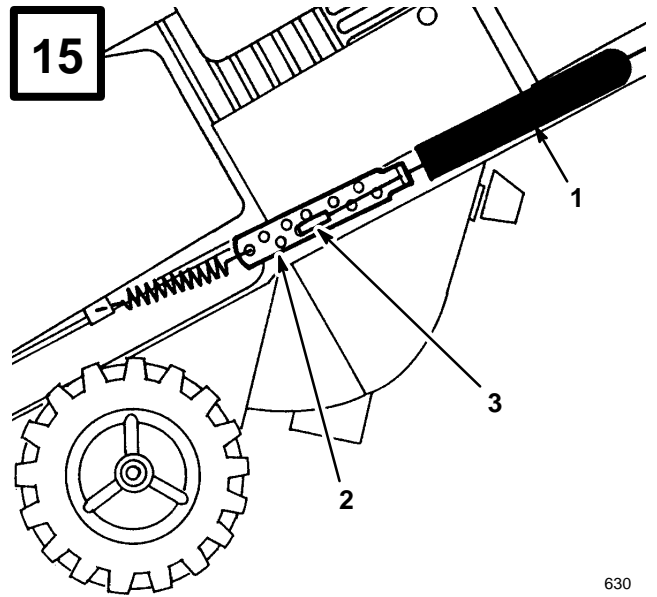

630

Models 38433 & 38438

- 1. Spring cover
- 2. Cable adjuster
- 3. Z fitting

16

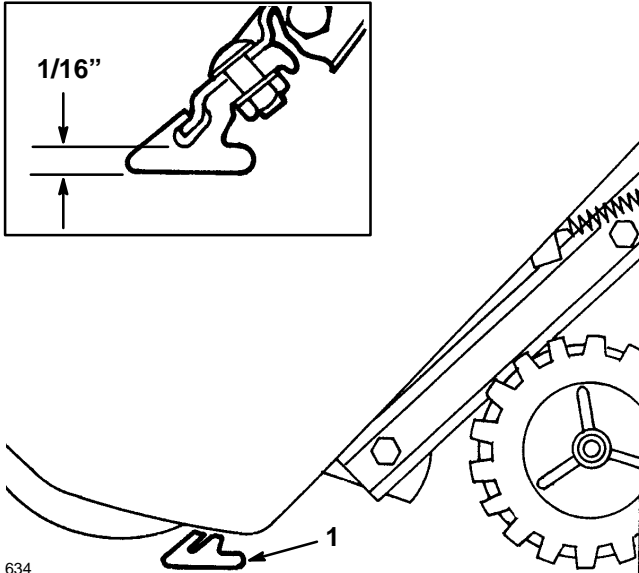

634

- 1. Scraper

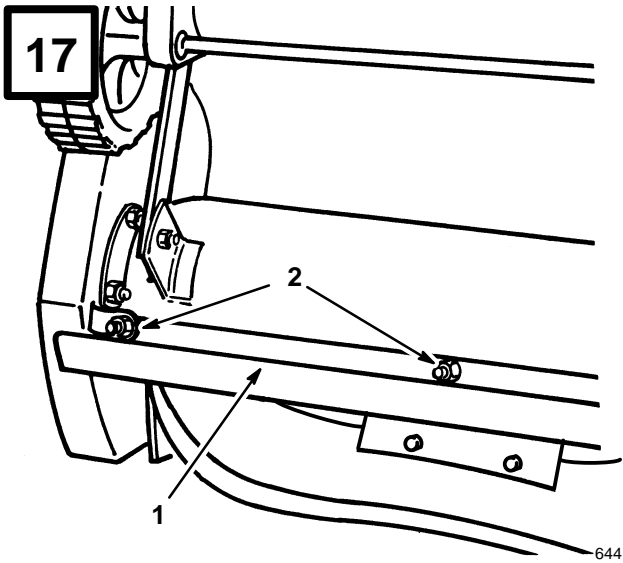

644

- 1. Scraper
- 2. Carriage bolts & lock nuts (3)

18

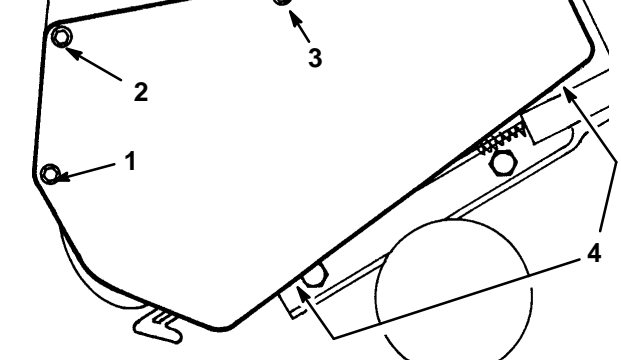

631

- 1. Cap screw, nut
- 2. Capscrew, nut, washer
- 3. Long self tapping screw
- 4. Short self tapping screws

19

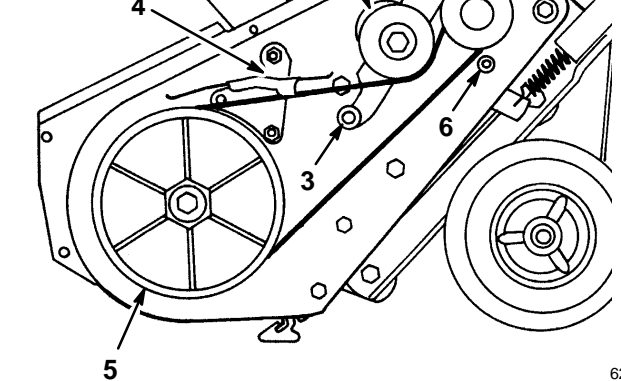

626

- 1. Engine pulley
- 2. Idler pulley
- 3. Roller
- 4. Brake arm assembly
- 5. Rotor pulley
- 6. Belt guide

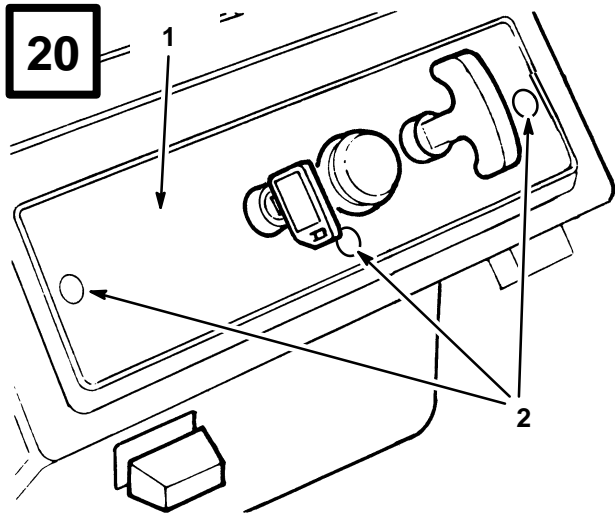

1. Control panel 2. Mounting screws

643

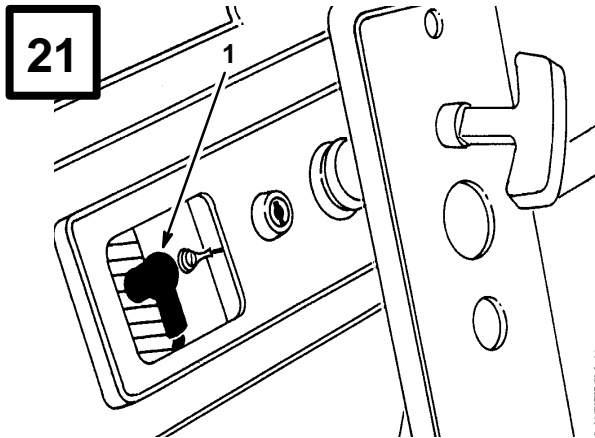

1. Spark plug wire

628

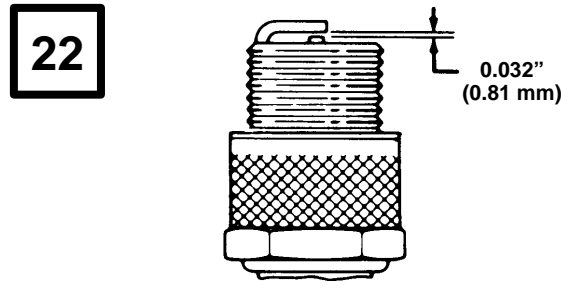

110

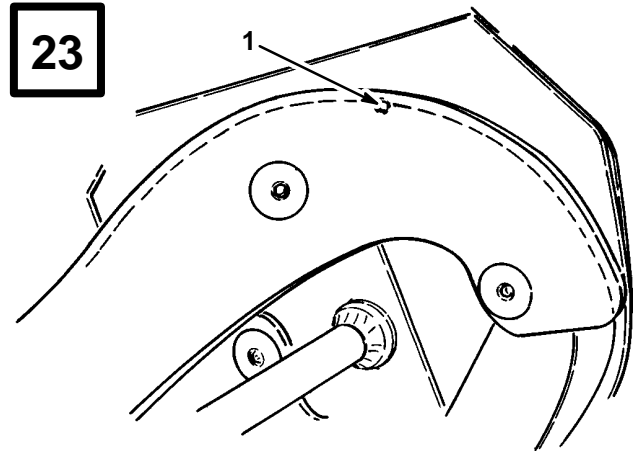

1. Wear indicator hole

24

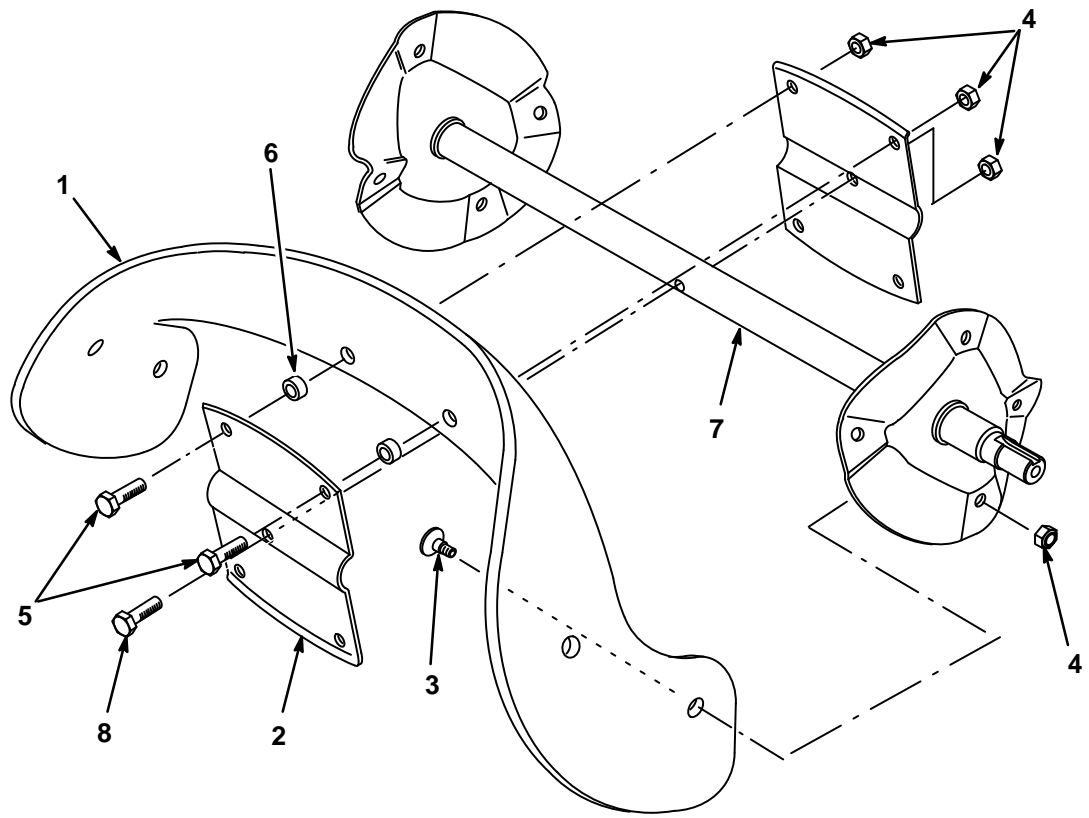

680

- 1. Rotor blade (2)
- 2. Rotor half (2)
- 3. Torx screw (8)
- 4. Locknut (13)
- 5. Hex-head capscrew (4)
- 6. Spacer (4)
- 7. Auger shaft assembly
- 8. Hex-head screw

25

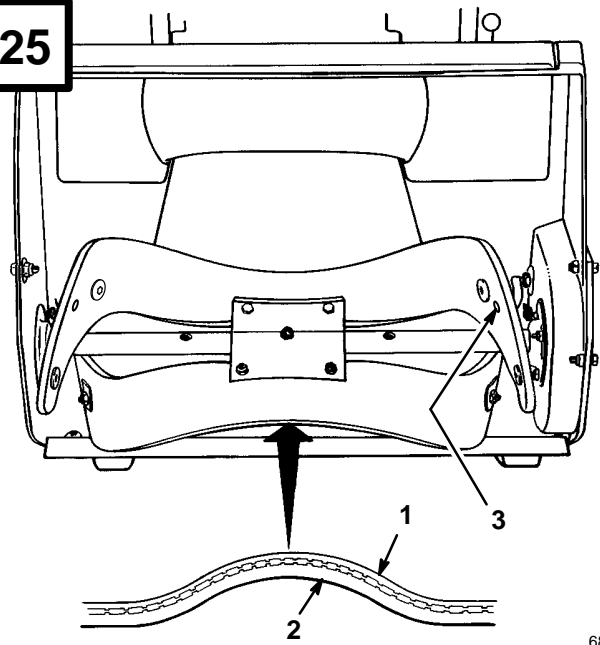

681

- 1. Thin layer
- 2. Thick layer
- 3. Wear indicator hole

Contents

	Page
Introduction	1
Safety	2
Before Operating	2
While Operating	3
Maintaining Snowthrower	3
Sound Pressure Level	4
Sound Power Level	4
Vibration Level	4
Symbol Glossary	4
Assembly	8
Install Wheels	8
Install Discharge Chute And Chute Handle	8
Install Chute Crank	8
Install Discharge Chute	9
Install Handle	9
Install Control Cable	9
Install Control Cable	9
Before Starting	10
Mix Gasoline And Oil	10
Operation	11
Starting/Stopping Engine	11
Operating Tips	11
Maintenance	13
Adjusting Control Bar	13
Draining Gasoline	13
Replacing Scraper	14
Replacing Drive Belt	14
Replacing Spark Plug	14
Adjusting Carburetor	14
Replacing Rotor Blades	14
Storage	15

Introduction

Thank you for purchasing a Toro product.

All of us at Toro want you to be completely satisfied with your new product, so feel free to contact your local Authorized Service Dealer for help with service, genuine Toro parts, or other information you may require.

Whenever you contact your Authorized Service Dealer or the factory, always know the model and serial numbers of your product. These numbers will help the Service Dealer or Service Representative provide exact information about your specific product. You will find the model and serial number decal located in a unique place on the product (Fig. 1).

For your convenience, write the product model and serial numbers in the space below.

<p>Model No: _____</p> <p>Serial No. _____</p>
--

Read this manual carefully to learn how to operate and maintain your product correctly. Reading this manual will help you and others avoid personal injury and damage to the product. Although Toro designs, produces and markets safe, state-of-the-art products, you are responsible for using the product properly and safely. You are also responsible for training persons who you allow to use the product about safe operation.

The Toro warning system in this manual identifies potential hazards and has special safety messages that help you and others avoid personal injury, even death. DANGER, WARNING and CAUTION are signal words used to identify the level of hazard. However, regardless of the hazard, be extremely careful.

DANGER signals an extreme hazard that will cause serious injury or death if the recommended precautions are not followed.

WARNING signals a hazard that may cause serious injury or death if the recommended precautions are not followed.

CAUTION signals a hazard that may cause minor or moderate injury if the recommended precautions are not followed.

Two other words are also used to highlight information. “Important” calls attention to special mechanical information and “Note” emphasizes general information worthy of special attention.

The left and right side of the machine is determined by standing behind the handle in the normal operator’s position.

Safety

To ensure maximum safety, best performance, and to gain knowledge of the product, it is essential that you or any other operator of the snowthrower read and understand the contents of this manual before the motor is ever started. Pay particular attention to the safety alert symbol  which means CAUTION, WARNING OR DANGER — “personal safety instruction.” Read and understand the instruction because it has to do with safety. Failure to comply with instruction may result in personal injury.

This snowthrower is designed and tested to offer safe and effective service, provided it is operated in strict accordance with the following Safety Instructions. Failure to comply with the following instructions **MAY RESULT IN PERSONAL INJURY.**

Before Operating

1. Read and understand the contents of this manual before operating the snowthrower. Become familiar with all controls and know how to stop engine and snowthrower quickly.
2. Never allow children to operate the snowthrower. Adults should operate the snowthrower only after reading this manual.

3. Keep everyone, especially children and pets, away from snowthrower and area of operation.
4. Inspect area thoroughly where snowthrower will be used. Remove doormats, sleds, boards, sticks, wire and any other foreign objects which might be picked up and thrown by the snowthrower.
5. Keep all shields and safety devices in place. If a shield, safety device or decal is illegible, damaged or lost, repair or replace it before beginning operation. Also, tighten any loose nuts, bolts or screws.
6. Wear adequate winter clothing and rubber boots that will ensure proper footing on slippery surfaces. Do not wear loose-fitting clothing that could possibly get caught in moving parts.
7. Always wear safety glasses or eye shields during operation or while performing an adjustment or repair to protect eyes from foreign objects that may be thrown from the machine.
8. Fill fuel tank with gasoline before starting the engine. Avoid spilling any gasoline. Because fuel is highly flammable, handle it carefully. **DO NOT SMOKE WHILE HANDLING GASOLINE.**
 - A. Use an approved gasoline container.
 - B. Fill fuel tank outdoors, not indoors. **NEVER ADD FUEL TO AN ENGINE THAT IS RUNNING OR HOT.** Engine must be cool to reduce potential fire hazard.
 - C. Open doors if engine will be started in the garage because exhaust fumes are dangerous and could possibly be deadly. Do not run engine indoors.
 - D. Wipe up any spilled gasoline. Reinstall gasoline container cap and snowthrower fuel tank cap securely before starting the engine.
9. Allow engine to warm up outdoors before operating. Do not run engine indoors.

While Operating

10. Use only the extension cord and receptacle provided with the electric start model snowthrower. Do not plug the extension cord into outlet while standing in water or when hands are wet. Do not use cord if gasoline has been spilled. If extension cord is damaged, replace immediately (Part No. 28-9170).
11. Never direct discharge toward or operate snowthrower near bystanders, glass enclosures, automobiles and trucks, window wells or a drop-off. Never allow anyone in front of snowthrower.
12. Keep people and pets a safe distance away from the snowthrower and area of operation.
13. Operate the snowthrower only when there is good visibility or light. Always maintain secure footing and balance and keep a firm grip on the handle. Walk; never run.
14. **DO NOT USE SNOWTHROWER ON A ROOF.**
15. Be attentive when using the snowthrower, and stay alert for holes in the terrain and other hidden hazards.
16. **STAY AWAY FROM DISCHARGE OPENING WHILE OPERATING THE SNOWTHROWER.** Keep face, hands, feet, and any other part of your body or clothing away from concealed, moving, or rotating parts.
17. Never clear snow off steep slopes or across the faces of slopes. Exercise extreme caution when changing direction on slopes.
18. Do not overload the snowthrower by clearing snow at too fast a rate.
19. Use extreme caution when crossing or operating snowthrower on walks, roads or gravel or crushed rock drives. Refer to Operating Tips, page 7, item 4 for correct operating procedure.
20. If a foreign object is hit or snowthrower vibrates abnormally, stop engine by turning key to OFF and wait for all moving parts to stop. Check snowthrower immediately for possible damage, an obstruction or loose parts. Vibration is generally a sign of trouble. Repair any damage before operating snowthrower again.
21. Before adjusting, cleaning, repairing or inspecting the snowthrower, or before unclogging the discharge chute, stop engine by turning key to OFF and wait for all moving parts to stop. Disconnect the spark plug wire and keep the wire away from the plug to prevent someone from accidentally starting the unit. Do not make adjustments while engine is running.
22. **WHENEVER YOU LEAVE THE OPERATING POSITION, STOP ENGINE BY TURNING KEY TO OFF. REMOVE KEY FROM SWITCH IF UNIT WILL BE UNATTENDED.**
23. Let snowthrower run for a few minutes after clearing snow so moving parts do not freeze.

Maintaining Snowthrower

24. REMOVE KEY FROM SWITCH when storing snowthrower. Store key in a memorable place.
25. Never store snowthrower with fuel in fuel tank inside a building where ignition sources such as an open flame, sparks, hot water and space heaters, and clothes dryers are present. Allow engine to cool before storing. **NEVER STORE SNOWTHROWER IN HOUSE (LIVING AREA) OR BASEMENT BECAUSE GASOLINE AND FUMES ARE HIGHLY FLAMMABLE, EXPLOSIVE, AND DANGEROUS IF INHALED.**
26. Perform only those maintenance instructions described in this manual. Remove key from switch before performing maintenance procedures to prevent the possibility of accidental starting. If major repairs are ever needed, contact your local Authorized TORO Service Dealer for assistance.

- 27. Keep snowthrower in safe operating condition by keeping nuts, bolts, and screws tight. Check all fasteners frequently to ensure they are tight.
- 28. Maintain or replace safety and instruction labels, as necessary.
- 29. To ensure best performance and safety, purchase genuine TORO replacement parts and accessories to keep your TORO all TORO. **NEVER USE “WILL FIT” REPLACEMENT PARTS AND ACCESSORIES.**

Sound Pressure Level

Models 38412 & 38418

This unit has a sound pressure at the operator’s ear of 90 dB(A), based on measurements of identical machines per Directive 81/1051/EEC.

Models 38433 & 38438

This unit has a sound pressure at the operator’s ear of 91 dB(A), based on measurements of identical machines per Directive 81/1051/EEC.

Symbol Glossary

Safety alert triangle — symbol within triangle indicates a hazard



Safety alert symbol



Read operator’s manual



Sound Power Level

Models 38412 & 38418

This unit has a sound power level of 103 LwA, based on measurements of identical machines per Directive 79/113/EEC.

Models 38433 & 38438

This unit has a sound power level of 105 LwA, based on measurements of identical machines per Directive 79/113/EEC.

Vibration Level

Models 38412 & 38418

This unit has a maximum hand-arm vibration level of 28.5 m/s², based on measurements of identical machines per EN 1033.

Models 38433 & 38438

This unit has a maximum hand-arm vibration level of 30 m/s², based on measurements of identical machines per EN 1033.

Do not open or remove safety shields while engine is running

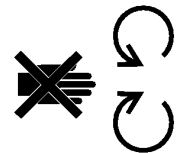

Stay a safe distance from the machine

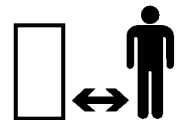

Stay a safe distance from the machine – single stage snowthrower



Consult technical manual for proper service procedures



Shut off engine and remove key before performing maintenance or repair work

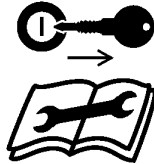

Shut off engine and remove key before leaving operator position – single stage snowthrower



Shut off engine and remove key before leaving operator position – two stage snowthrower



Severing of fingers or hand – impeller blade



Hot surfaces – burns to fingers or hands



Caustic liquids – chemical burns to fingers or hands



Stay a safe distance from the machine – two stage snowthrower

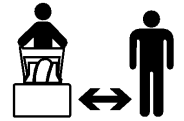

Thrown or flying objects – Whole body exposure

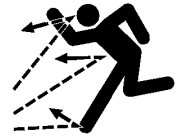

Electrical shock – electrocution



Cutting or entanglement of foot – rotating auger



Electric start



Machine loss of control – uphill slope



Machine loss of control – downhill slope



Do not tip battery

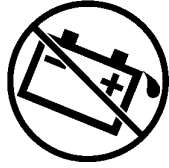

Traction drive



Keep dry



Snowthrower collector auger

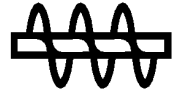

Machine travel direction – forward



Engage

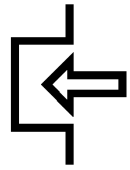

Machine travel direction – rearward



Disengage

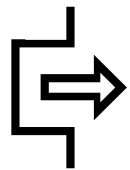

On/start



Choke

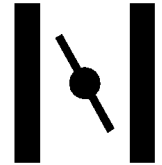

Off/stop

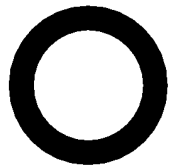

Engine speed (Throttle)



Fast



Neutral



Slow



Snowthrower collector auger



Decreasing/Increasing



Lock



Engine start



Unlock



Engine stop



Lever operation

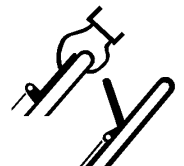

Snowthrower chute direction



Lever operation



Primer (start aid)



Unleaded fuel



Primer operation

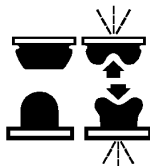

Cutting of fingers or hand



Throttle operation

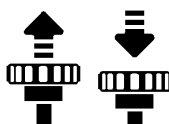

Cutting of foot



PowerShift operation

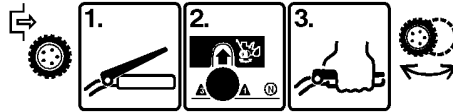

Belt routing

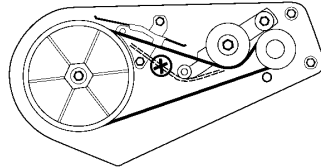

Assembly

Note: Determine left and right sides of the snowthrower by standing in the normal operator's position behind the handles.

Install Wheels (Fig. 2)

1. Carefully turn machine onto its left side. Place a wood block under the left axle end.
2. Slide the **short** spacer and a wheel onto the right axle end. The side of the wheel with six spokes must face the center of the machine.
3. Slide a pushnut onto the end of the axle.
4. Using a hammer, strike the pushnut to seat the nut **FIRMLY** in place.
5. Turn the machine over on its right side so that the left axle end is pointing up.
6. For the left side, slide the **long** spacer and a wheel onto the left axle end. The side of the wheel with six spokes must face the center of the axle.
7. Place a wood block under the right axle end. Repeat steps 3 and 4.

Install Discharge Chute And Chute Handle (Fig. 3)

Models 38412 & 38418

1. Place chute handle over chute ring.
2. Insert discharge chute between chute ring and chute handle. Align holes.
3. Secure back of chute and handle to center hole in chute ring with a carriage bolt and lock nut. Position nut on outside of chute.

Note: Chute ring may be rotated to ease assembly of discharge chute.

4. Secure chute and handle to remaining holes in chute ring and tighten all nuts **SECURELY**.

Install Chute Crank (Fig. 4)

Models 38433 & 38438

1. Insert flattened end of chute crank through hole in shroud while aligning mounting bracket with holes in lower handle. Slowly rotate crank until flattened end fits into hidden gear opening and chute ring turns with crank. Make sure plastic bushing is fully inserted into hole in mounting bracket, then secure mounting bracket to handle with (2) capscrews and locknuts.

Install Discharge Chute (Fig. 5)

Models 38433 & 38438

1. Set discharge chute onto chute ring. Align hole in back of chute with center hole in ring and install a carriage bolt and sems locknut. Position nut on outside of chute.

Note: Chute ring may be rotated to ease assembly of discharge chute.

2. Secure chute to remaining holes in chute ring and tighten all nuts **SECURELY**.

Install Handle

1. Remove tie securing control cable to lower handle.
2. Position upper handle so that control bar is on top of handle, not underneath it.
3. **Models 38412 & 38418** – Secure upper handle in place with (3) handle bolts, (1) eyebolt, and (4) lock nuts. Use eyebolt to mount upper left side of handle. Eyebolt must be positioned perpendicular to handle when tightened (Fig. 6).

Models 38433 & 38438 – Secure upper handle in place with (2) handle locks, (1) cable guide, (2) curved washers and (2) knobs. Cable guide must be perpendicular to handle with loop facing out and up (Fig. 7).

Install Control Cable

Models 38412 & 38418

1. Route control cable through eyebolt on left side of snowthrower (Fig. 8).
2. Hook spring to round hole at end of cable adjuster (Fig. 9).

3. Route cable through elongated hole in cable adjuster. Insert Z fitting on end of cable into 3rd hole on cable adjuster (Fig. 9).
4. Slide spring cover over spring and cable adjuster. Push spring end through hole at end of spring cover (Fig. 8).
5. Hook spring into top hole of control bar bracket (Fig. 8).
6. Move control bar back toward handle until slack in cable is removed. The gap between the control bar bracket and handle should be approximately 1/16”-1/8”. See insert, Figure 8. If an adjustment is required, refer to Adjusting Control Bar, page 13.

Note: The control cable must always have slack in it when in the disengaged position.

Install Control Cable

Models 38433 & 38438

1. Route control cable through cable guide on left side of snowthrower (Fig. 10).
2. Hook upper end of control cable in rear hole (hole with arrow) in control bar bracket (Fig. 10).
3. Move control bar back toward handle until slack in cable is removed. The gap between bottom of handle and stop on control bar (left hand side on bottom of handle) should be approximately 1/16”-1/8”. See insert, Figure 10. If an adjustment is required, refer to Adjusting Control Bar, page 13.

Note: The control cable must always have slack in it when in the disengaged position.

Before Starting

DANGER

POTENTIAL HAZARD

- In certain conditions gasoline is extremely flammable and highly explosive.

WHAT CAN HAPPEN

- A fire or explosion from gasoline can burn you, others, and cause property damage.

HOW TO AVOID THE HAZARD

- Use a funnel and fill the fuel tank outdoors, in an open area, when the engine is cold. Wipe up any gasoline that spills.
- Do not fill the fuel tank completely full. Add gasoline to the fuel tank until the level is 1/4" to 1/2" (6 mm to 13 mm) below the bottom of the filler neck. This empty space in the tank allows gasoline to expand.
- Never smoke when handling gasoline, and stay away from an open flame or where gasoline fumes may be ignited by a spark.
- Store gasoline in an approved container and keep it out of the reach of children.
- Never buy more than a 30-day supply of gasoline.

Mix Gasoline And Oil (Fig. 11)

Use clean, fresh lead-free gasoline, including *oxygenated* or *reformulated* gasoline, with an octane rating of 85 or higher. To ensure freshness, purchase only the quantity of gasoline that can be used in 30 days. Use of lead-free gasoline results in fewer combustion chamber deposits and longer spark plug life. Use of premium grade fuel is not necessary or recommended.

1. APPROVED OIL—For simplicity and best engine performance, mix the contents of one 5.2-ounce bottle of Toro 50:1 Two-Cycle Oil with two gallons of fresh, unleaded regular gasoline.

Toro Two-Cycle Oil is specially formulated to provide superior lubrication, make starting easy, and prolong engine life. If Toro Two-Cycle Oil is not available, mix two gallons of gasoline and 5.2 ounces of another high grade two-cycle oil that has the NMMA or BIA-TCW III certification printed on the label.

NEVER USE AUTOMOTIVE OIL (i.e. SAE 30, 10W30 etc.), TWO-CYCLE OIL THAT IS NOT CERTIFIED NMMA/BIA-TCW III, OR THE WRONG MIX RATIO BECAUSE THE ENGINE CAN BE DAMAGED, AND IT WOULD NOT BE COVERED BY THE TORO WARRANTY.

2. Mixing Gasoline and Oil—Pour a half gallon of gasoline into an approved gasoline container (preferably plastic, not metal) and add the correct amount of two-cycle oil. Reinstall cap on gasoline container and shake the container to mix oil and gas thoroughly. Remove cap and add remaining amount of gasoline.

Toro also recommends that Toro Stabilizer/Conditioner be used regularly in all Toro gasoline powered products during operation and storage seasons. Toro Stabilizer/Conditioner cleans the engine during operation and prevents gum-like varnish deposits from forming in the engine during periods of storage.

Note: A fuel stabilizer/conditioner is most effective when mixed with fresh gasoline.

IMPORTANT: NEVER USE METHANOL, GASOLINE CONTAINING METHANOL, GASOHOL CONTAINING MORE THAN 10% ETHANOL, PREMIUM GASOLINE, OR WHITE GAS BECAUSE ENGINE FUEL SYSTEM DAMAGE COULD RESULT.

DO NOT USE FUEL ADDITIVES OTHER THAN THOSE MANUFACTURED FOR FUEL STABILIZATION DURING STORAGE SUCH AS TORO'S STABILIZER/CONDITIONER OR A SIMILAR PRODUCT. TORO'S STABILIZER/CONDITIONER IS A

PETROLEUM DISTILLATE BASED CONDITIONER/STABILIZER. TORO DOES NOT RECOMMEND STABILIZERS WITH AN ALCOHOL BASE SUCH AS ETHANOL, METHANOL OR ISOPROPYL. ADDITIVES SHOULD NOT BE USED TO TRY TO ENHANCE THE POWER OR PERFORMANCE OF MACHINE.

Note: Do not mix gasoline and oil in the product fuel tank. Oil that is at room temperature mixes easier and more thoroughly than cold oil.

50:1 GAS/OIL Mixing Chart

U.S. GALLON	
Gasoline	Oil
1 gallon	2.6 oz.
1.5 gallons	3.9 oz.
2 gallons	5.2 oz.

Operation

Starting/Stopping Engine (Fig. 12)

1. CONTROLS—Key switch, primer, recoil starter, and electric start button are located on the control panel. The choke is just below the control panel.
2. Turn key to ON and pull choke out.
3. Cover hole in center of primer with thumb and push twice. Additional primes may be necessary in extremely cold temperatures.

Note: Choke and primer are usually not necessary when starting a warm engine.

4. STARTING

- A. RECOIL STARTING—Hold snowthrower with one hand and pull recoil starter vigorously with other hand.

- B. ELECTRIC STARTING—Connect extension cord to snowthrower and standard household power outlet. Push starter button. When engine starts, disconnect extension cord from snowthrower and outlet.

IMPORTANT: Excessive running of the electric starter could damage the starter due to overheating. If you are having difficulty starting the engine, ONLY TRY THIS STARTING PROCEDURE TWICE. Run the electric starter no more than 10 times at intervals of 5 seconds ON, 5 seconds OFF. If engine does not start after this first attempt, wait more than 40 minutes to allow starter to cool before trying to run starter again. Before repeating engine starting procedure, check that ignition key switch is ON, and make sure there is fresh fuel in fuel tank. If engine still will not start after a second attempt, bring the snowthrower to an Authorized Toro Service Dealer for servicing.

IMPORTANT: Do not leave the electric starter cord connected to the power outlet when storing the snowthrower. It should only be connected to the power outlet during the starting procedure. If you leave it connected to the power outlet during storage, a power surge could start the snowthrower when no one is in attendance.

5. When engine starts, push in choke slowly.
6. TO START/STOP ROTOR—To start rotor, squeeze control bar to handle. When the control bar handle is released, the rotor blades stop, but the engine continues to run.
7. TO STOP ENGINE—Release control bar to stop rotor, turn key to OFF, and wait for all moving parts to stop before leaving operator's position.

Operating Tips

1. ADJUSTING DISCHARGE CHUTE (Models 38412 & 38418) (Fig. 13)—Move the chute handle left and right to adjust the direction of the snow stream. The chute deflector handle on top of the discharge chute controls the height

of the snow stream. Do not overtighten the chute deflector mounting nuts so excessive force is required to adjust the deflector.

IMPORTANT: Do not use chute handle to lift snowthrower; damage to chute handle could result.

ADJUSTING DISCHARGE CHUTE

(Models 38433 & 38438) (Fig. 14)–Rotate chute crank clockwise to move discharge chute to the right and counterclockwise to move chute to the left. The chute deflector handle on top of the discharge chute controls the height of the snow stream. Do not overtighten the chute deflector mounting nuts so excessive force is required to adjust the deflector.

- 2. SELF-PROPELLING ACTION**–The snowthrower clears down to the ground and propels itself forward when the handle is raised and the snowthrower is tilted **slightly** forward so rotor blades strike the ground. The wheels do not have to touch the ground in order to self-propel. The further you tilt the handle forward, the faster the snowthrower self-propels. However, height and density of snow affects forward speed. Always overlap each swath and discharge downwind whenever possible.
- 3.** Keep the area to be cleared free of stones, toys or other foreign objects which may be picked up and thrown by the rotor blades. Such items could be covered by snowfall and, therefore, unnoticed until struck by the rotor blades. Always be sure to keep children and pets away from area of operation.

WARNING

POTENTIAL HAZARD

- **Stones, toys and other foreign objects may be picked up and thrown by the rotor blades.**

WHAT CAN HAPPEN

- **Thrown objects can cause serious personal injury to operator or bystanders.**

HOW TO AVOID THE HAZARD

- **Keep the area to be cleared free of all objects that could be picked up and thrown by rotor blades.**
- **Keep all children and pets away from area of operation.**

- 4.** Should you find it necessary to clear snow from crushed rock or gravel, push down on handle to raise rotor blades clear of loose material that could be thrown by the blades and push unit forward.
- 5.** In some snow and cold weather conditions, some controls and moving parts may freeze solid. **DO NOT USE EXCESSIVE FORCE WHEN TRYING TO OPERATE FROZEN CONTROLS.** When any control or part becomes hard to operate, start the engine and let it run for a few minutes.
- 6. AFTER CLEARING SNOW**–Let engine run for a few minutes so ice does not freeze moving parts solid. After engine is shut off, wipe ice and snow off entire unit. On models 38422 & 38424, operate chute crank several times to clear mechanism of snow.

IMPORTANT: STORE SNOWTHROWER IN OPERATING POSITION ON ITS WHEELS. TIPPING OR STORING UNIT FORWARD ONTO FRONT HOUSING MAY CAUSE HARD STARTING.

Maintenance

Keep snowthrower in safe operating condition by cleaning the unit and tightening nuts, bolts, and screws. The scraper, drive belt, rotor blades, and spark plug should be checked once a year.

Adjusting Control Bar

Periodically check control bar for proper adjustment.

1. Turn key switch to OFF.
2. CHECK ADJUSTMENT (Fig. 8 & 10)—Move control bar back toward handle until slack in cable is removed. Gap between control bar bracket and handle should be approximately 1/16"–1/8". If cable is too loose or too tight, proceed to step 3 for adjustment procedure.

Note: The control cable must always have slack in it when in the disengaged position.

3. ADJUST CABLE
 - A. Models 38412 & 38418 – Unhook spring end from the top hole in control bar bracket (Fig. 8). Slide spring cover off spring and cable adjuster. Unhook Z fitting from cable adjuster and reposition Z fitting in a higher or lower hole on adjuster to obtain proper gap of 1/16"–1/8" between control bar bracket and handle (Fig. 9). (Positioning cable end in a lower hole decreases gap; positioning cable end in a higher hole increases gap.) Reinstall spring cover over cable adjuster and spring. Rehook spring into top hole of control bar bracket (Fig. 8).
 - B. Models 38433 & 38438 – Unhook upper cable end from hole in control bar bracket (Fig. 10). Slide spring cover up cable to expose cable adjuster (Fig. 15). Unhook Z fitting from cable adjuster and reposition Z

fitting in a higher or lower hole on adjuster to obtain proper gap of 1/16"–1/8" between control bar bracket and handle (Fig. 10). (Positioning cable end in a lower hole decreases gap; positioning cable end in a higher hole increases gap.) Reinstall spring cover over cable adjuster. Reinstall upper cable end into rear hole in control bar bracket (hole with arrow) (Fig. 10).

4. After extended use the drive belt may wear and proper belt tension may not be maintained. Improper belt tension causes belt slippage and decreases the snowthrower's performance under a heavy load. Belt slippage may occur after 2–3 seasons of normal usage (10–15 hours). If drive belt slips (continuous squealing noise) under heavy load, increase belt tension by:
 - A. Models 38412 & 38418 – repositioning spring end in bottom hole in control bar bracket (Fig. 8).
 - B. Models 38433 & 38438 – repositioning upper cable end into forward hole in control bar bracket (Fig. 10).

Readjust cable (see steps 2–3).

IMPORTANT: Unnecessary use of forward or bottom adjusting hole in control bar bracket reduces drive belt life. Occasional belt slippage (squealing) may occur in extremely wet conditions due to moisture in drive system. To remove moisture, start rotor and operate under no load for 30 seconds. Once moisture is removed, belt should not slip.

Draining Gasoline

1. Stop engine. Remove key from switch.
2. Remove cap from fuel tank and use a pump type siphon to drain fuel into a clean gas can.

Note: This is the only procedure recommended for draining fuel.

Replacing Scraper

Before each season, inspect scraper for wear. If thickness of bottom of scraper is less than 1/16" (1.6 mm), replace scraper (Fig. 16).

Note: Scraper wear rates are determined by the running time and the roughness of the driveway or sidewalk.

1. Turn ignition key to OFF.
2. Drain gasoline from fuel tank; refer to Draining Gasoline, page 13.
3. Tip snowthrower forward onto front housing.
4. Remove (3) carriage bolts and lock nuts holding scraper in place (Fig. 17). Remove scraper by sliding it to right and down.
5. Install new scraper to housing using carriage bolts and nuts.

Replacing Drive Belt

Inspect drive belt before each season. If ribs on inside of belt are damaged or belt is worn, replacement is necessary.

1. Turn ignition key to OFF.
2. Remove (3) self tapping screws, (2) capscrews, (1) washer and (2) nuts securing belt cover to snowthrower frame (Fig. 18). Set belt cover aside.
3. REMOVING BELT (Fig. 19)—Push down on idler pulley allowing belt to be removed from rotor pulley, brake arm assembly, and engine pulley.
4. INSTALLING BELT (Fig. 19)—Loop belt around engine pulley, under idler pulley, over roller, through brake assembly, and around rotor pulley.

IMPORTANT: Belt must be on top of roller as shown.

5. Reinstall belt cover. Tighten fasteners securely, but DO NOT OVERTIGHTEN.

Replacing Spark Plug

Before each snow season, check the spark plug. If electrodes in center of plug are dark or have deteriorated, install a new plug. Use an NGK BPMR4A spark plug and set gap at .032" (.81 mm).

1. REMOVE CONTROL PANEL (Fig. 20)—Remove (3) capscrews securing control panel to housing. Remove ignition key and lift off panel, allowing it to hang on recoil rope.
2. REMOVE SPARK PLUG (Fig. 21)—Pull wire off spark plug and remove plug. Examine the plug and replace if cracked, fouled or dirty. **DO NOT SANDBLAST, SCRAPE OR CLEAN SPARK PLUG BECAUSE DIRT MAY RELEASE AND FALL INTO CYLINDER CAUSING ENGINE DAMAGE.**
3. INSTALL SPARK PLUG—Set air gap (Fig. 22) between electrodes at .032" (.81 mm). Install plug and tighten to 15 ft-lb (20.4 N-m). If torque wrench is not used, tighten plug firmly. Push wire onto spark plug and reinstall control panel with (3) capscrews.

Adjusting Carburetor

The carburetor has been factory set, and no adjustment is required.

Replacing Rotor Blades

Before each snow season, inspect rotor blades for wear. When blade edge has worn to the wear indicator hole (Fig. 23), the blades must be replaced to ensure proper performance and prevent damage to underside of snowthrower. Always replace both blades at the same time.

Note: Whenever rotor blades are replaced, scraper should also be replaced to ensure proper snowthrower operation and performance.

Note: Rotor blades wear rates are determined by the running time and the roughness of the driveway or sidewalk.

Removing Old Blade

1. Remove (4) torx screws and (4) lock nuts securing outer edges of rotor blade to rotor shaft assembly (Fig. 24).
2. Next, remove (2) hex-head capscrews, spacers and lock nuts securing center of blade to rotor halves (Fig. 24).
3. Loosen the hex-head screw securing the rotor halves to the auger shaft assembly (Fig. 24).
4. Slide the blade out from between the rotor halves (Fig. 24).

Installing New Blade

1. The rotor blades are made of laminated rubber. Examine the edge of a blade to see the difference in layer thicknesses (Fig. 25). (Some blades have a part number on the thick side of the blade.)

Both blades must be installed with the thick layer on the **inside** of the curve. If one blade is installed with the thick layer on the outside of the curve and the other blade installed with the thick layer on the inside of the curve, the blades will be unbalanced, causing the snowthrower to “hop” or “bounce.”

2. Insert the new blade between the rotor halves. Secure it to the rotor halves with (2) hex-head capscrews, (2) spacers and (2) lock nuts (Fig. 24). Position bolt heads on thick (bottom) side of blade. Curve the blade, and secure it with the remaining (4) torx screws and lock nuts (position screw heads on thick side of blade). Tighten all screws and nuts securely.

Storage

1. FUEL SYSTEM PREPARATION—

Note: A fuel stabilizer/conditioner is most effective when mixed with fresh gasoline.

- Add Toro Stabilizer/Conditioner to the fuel tank (one ounce per gallon of fuel).
- Run engine for five minutes to distribute conditioned fuel through fuel system.
- Stop engine, allow it to cool, and drain fuel tank.
- Restart the engine again and run it until it stops.
- Either choke or prime the engine, restart it a third time and run engine until it will not restart.
- Dispose of fuel properly. Recycle per local codes.
- **DO NOT store STABILIZED gasoline over 90 days.**

2. CYLINDER/PISTON CARE—Slowly pull recoil starter until resistance is felt due to compression pressure, then stop. Release starter tension slowly to prevent engine from reversing due to compression pressure. This position closes both the intake and exhaust ports which prevents corrosion of the cylinder bore.

3. TIGHTEN FASTENERS AND CLEAN—Tighten screws, bolts, and nuts if necessary. Repair or replace damaged parts. Clean unit thoroughly.

4. STORE SNOWTHROWER—Cover snowthrower and store in a clean, dry place out of the reach of children. **NEVER STORE SNOWTHROWER IN HOUSE (LIVING AREA) OR BASEMENT WHERE IGNITION SOURCES MAY BE PRESENT SUCH AS HOT WATER AND SPACE HEATERS, CLOTHES DRYERS, AND THE LIKE BECAUSE GASOLINE AND FUMES ARE HIGHLY FLAMMABLE, EXPLOSIVE, AND DANGEROUS IF INHALED.** Allow engine to cool before storing in any enclosure.

