

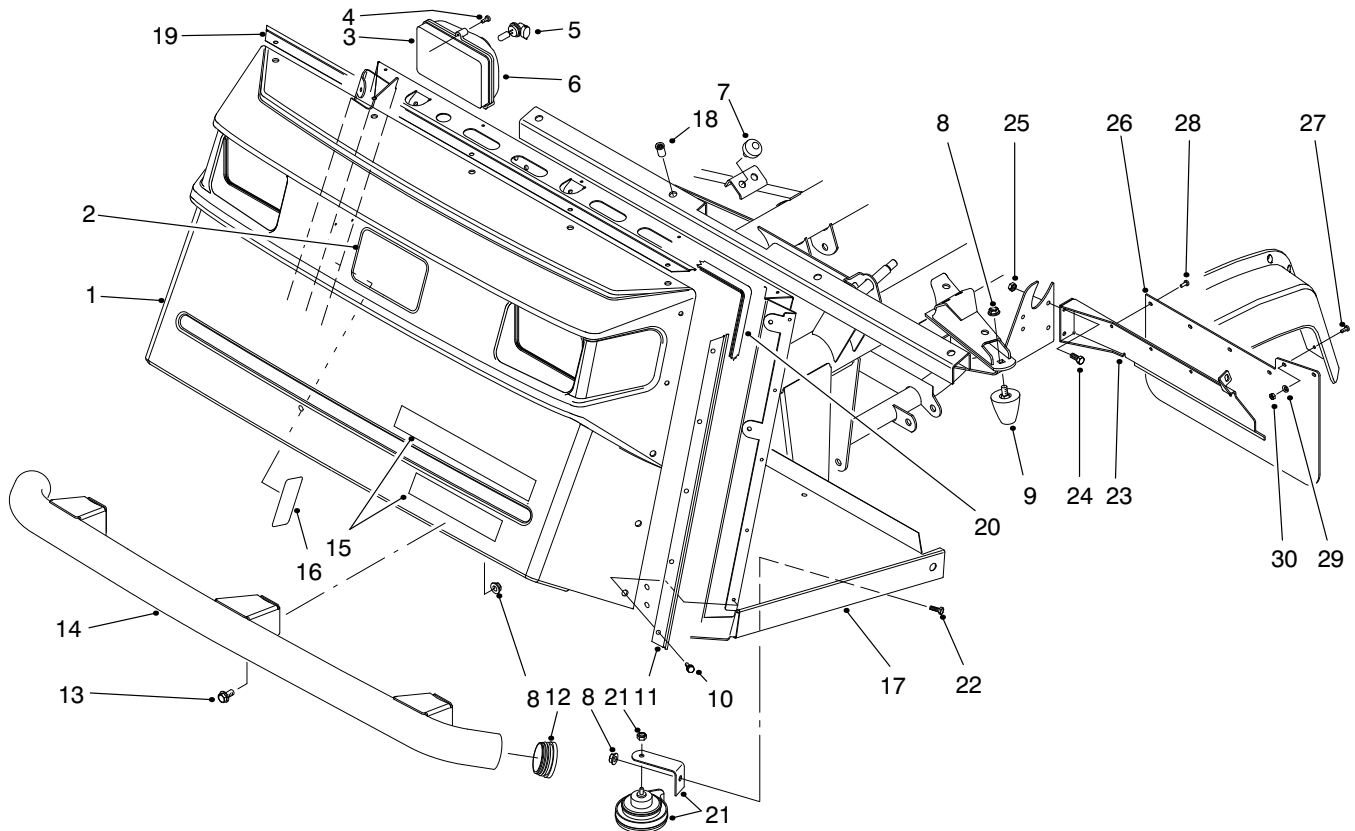

MODEL NO. 07210-90001

PARTS
CATALOG

WORKMAN® 3100



T-1581-1

FRONT BUMPER & HOOD ASSEMBLY

Ref. No.	Part No.	Description	No. Used
1	87-0710	Hood	1
2	62-5550	Decal - TORO	1
3	87-2120	Headlight Assembly (Incl. Ref. #5-6)	2
4	32104-88	Screw	6
5	87-6320	Bulb - Headlight	2
6	87-6330	Lens - Headlight	2
7	87-2440	Bumper	2
8	3290-357	Nut - Flange Lock	9
9	26-0071	Bumper	2
10	87-6620	Screw	15
11	87-8120	Bracket - Trim Side	2
12	2410-42	Cap - Front Bumper	2
13	3234-1	Screw - Hex. Flange Hd.	6
14	87-4070	Bumper - Front	1
15	87-6030	Decal - Workman 3100	1
16	87-9510	Decal - Load Rating	1

*Not Illustrated

Ref. No.	Part No.	Description	No. Used
17	94-5240	Operators Platform Assy. (Incl. Ref. #18)	1
18	32148-7	Nut - Clinch	8
19	87-8130	Bracket - Trim Top	1
20	87-8160	Trim	1
21	116749	Horn Assembly	1
22	323-4	Screw - Cap Hex. Hd.	1
23	94-3838	Bracket - Mudflap LH	1
*	94-3839	Bracket - Mudflap RH	1
24	321-4	Screw - Cap Hex. Hd.	4
25	32128-33	Nut - Lock	4
26	94-3841	Mudflap	2
27	3250-13	Screw - Pan Hd.	4
28	146489	Rivet - Pop	8
29	3256-61	Washer - Flat	4
30	3296-2	Nut - Lock	4

TPS

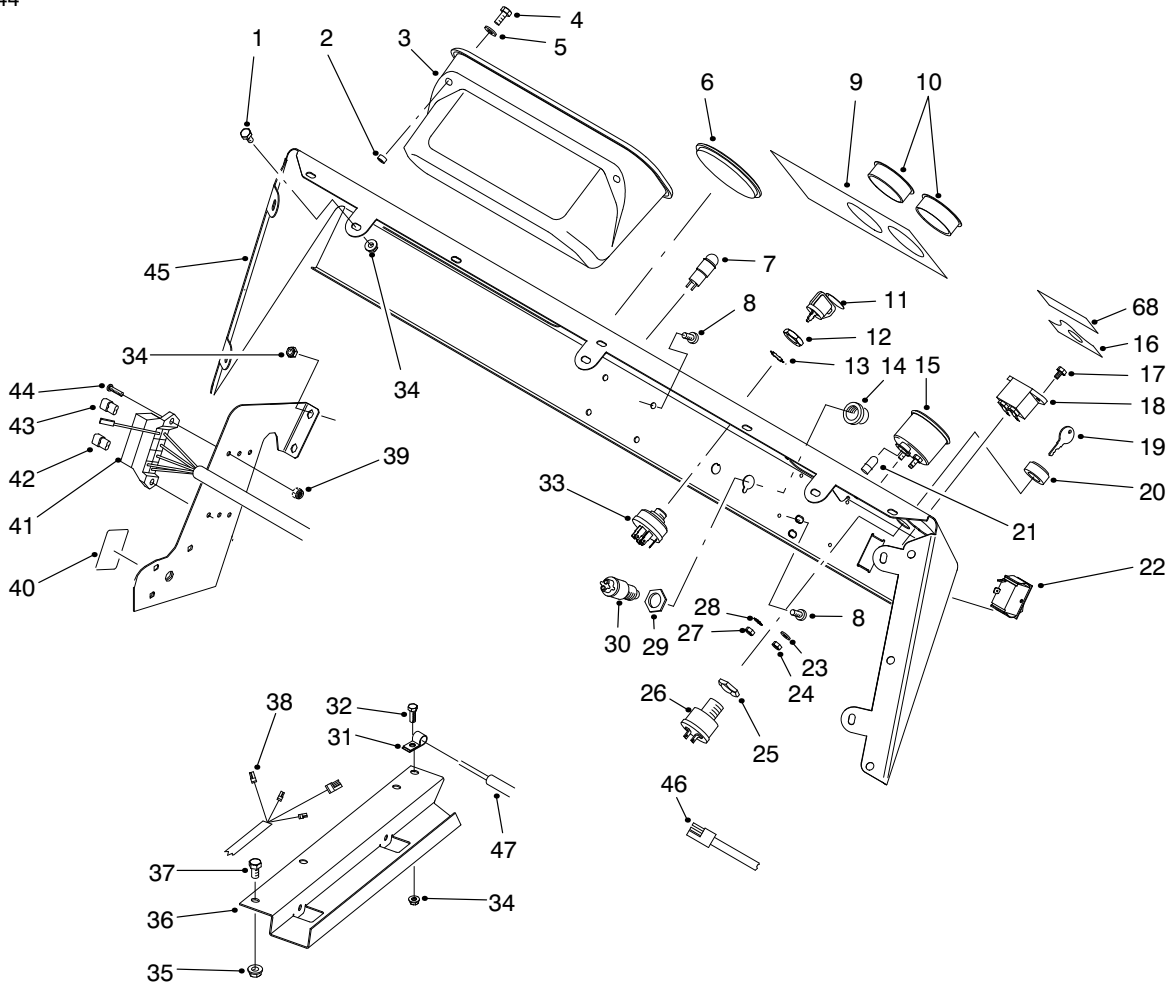

T-1729-1

CONTROL PANEL ASSEMBLY

Ref. No.	Part No.	Description	No. Used
1	321-2	Screw - Cap Hex. Hd.	7
2	32148-6	Insert - Threaded	2
3	87-3780	Box - Glove	1
4	321-3	Screw - Cap Hex. Hd.	2
5	3256-22	Washer - Flat	2
6	2410-35	Plug - Hole	1
7	87-8580	Light - Indicator (Red)	1
8	3274-31	Screw - Hex. Socket Hd.	4
9	87-7910	Decal - Dash	1
10	87-8360	Plug - Hole	2
11	63-8360	Key - Ignition	1
12	218-446	Nut - Hex.	1
13	218-447	Washer - Lock	1
14		Button - Horn	1
15	87-5580	Fuel Gauge Assembly (Incl. Ref. #23, 24, 27 & 28)	1
16	87-5910	Decal - Supervisor	1
17	32144-18	Screw - Cap Hex. Hd.	2
18	75-6820	Hourmeter	1
19	87-0740	Key - Supervisor Switch	1
20	87-1720	Nut - Supervisor Switch	1
21	218-600	Bulb	1
22	87-3790	Switch - Light	1
23	3253-15	Washer - Lock	2
24	3217-25	Nut - Hex	2
25		Nut - Hex.	1

Ref. No.	Part No.	Description	No. Used
26	94-5245	Supervisor Switch Assy. (Incl. Ref. #19, 20 & 25)	1
27	3217-29	Nut - Hex.	3
28	3253-19	Washer - Lock	3
29		Nut - Hex.	1
30	18-2830	Horn Switch Assembly (Incl. Ref. #14 & 29)	1
31	2412-89	Clamp - R	1
32	321-4	Screw - Cap Hex. Hd.	1
33	27-2360	Ignition Switch Assembly (Incl. Ref. #12 & 13)	1
34	32128-33	Nut - Flange	12
35	32128-20	Nut - Flange	3
36	93-7094	Cover - Wire Harness	1
37	322-2	Screw - Cap Hex. Hd.	3
38	99-1115	Harness - Wire Rear	1
39	3296-2	Nut - Lock	2
40	87-6670	Decal - Fuse Block	1
41	87-8200	Harness - Wire Front	1
42	218-574	Fuse 7.5 Amp.	2
43	218-578	Fuse 10 Amp.	1
44	3250-13	Screw	2
45	87-8560	Control Panel Assembly (Incl. Ref. #9, 16 & 48)	1
46	87-4230	Harness - Wire Front LH	1
47	94-3837	Cable - Clutch	1
48	94-5272	Decal - Warning	1

ELECTRICAL SCHEMATIC

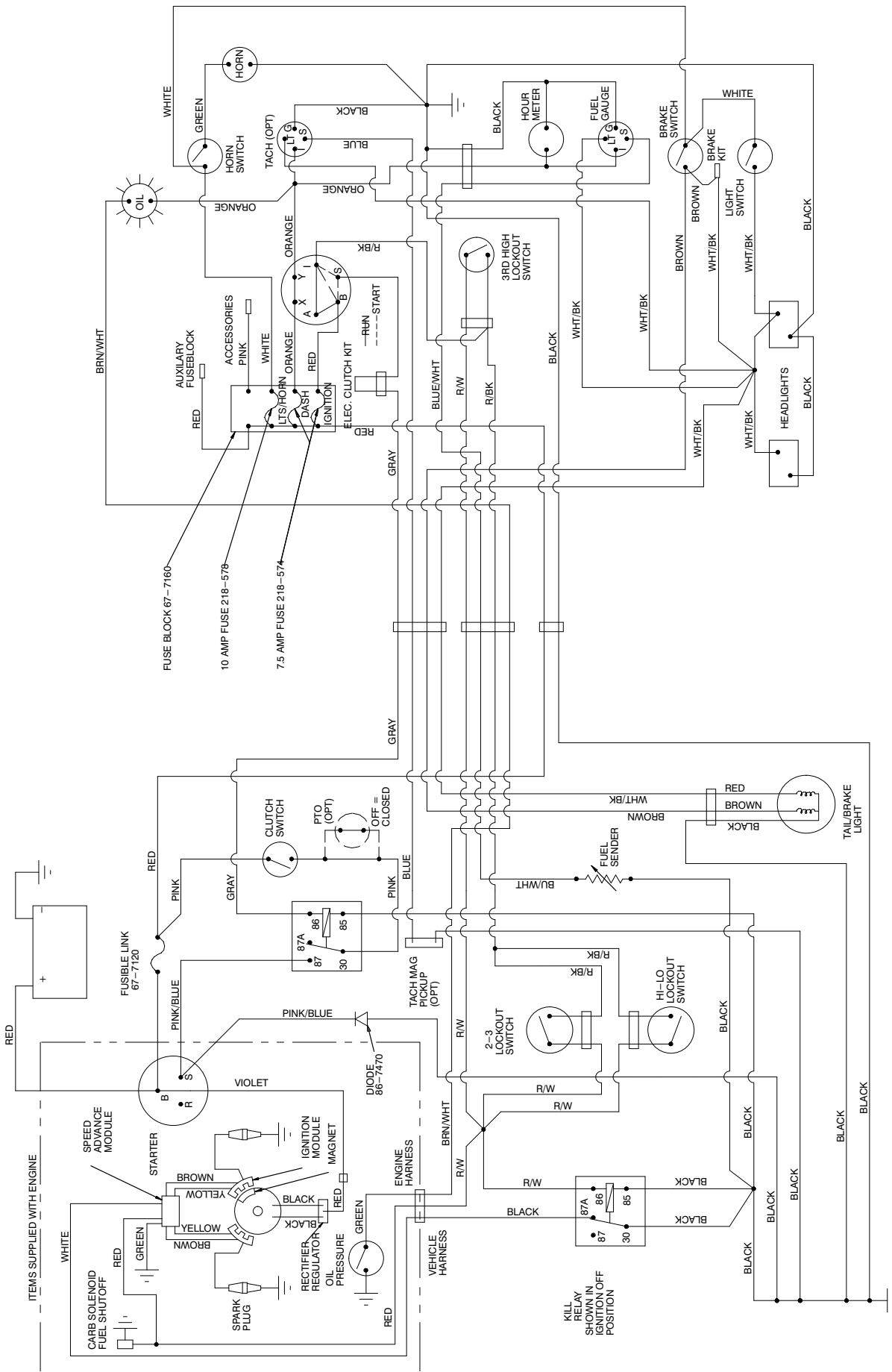

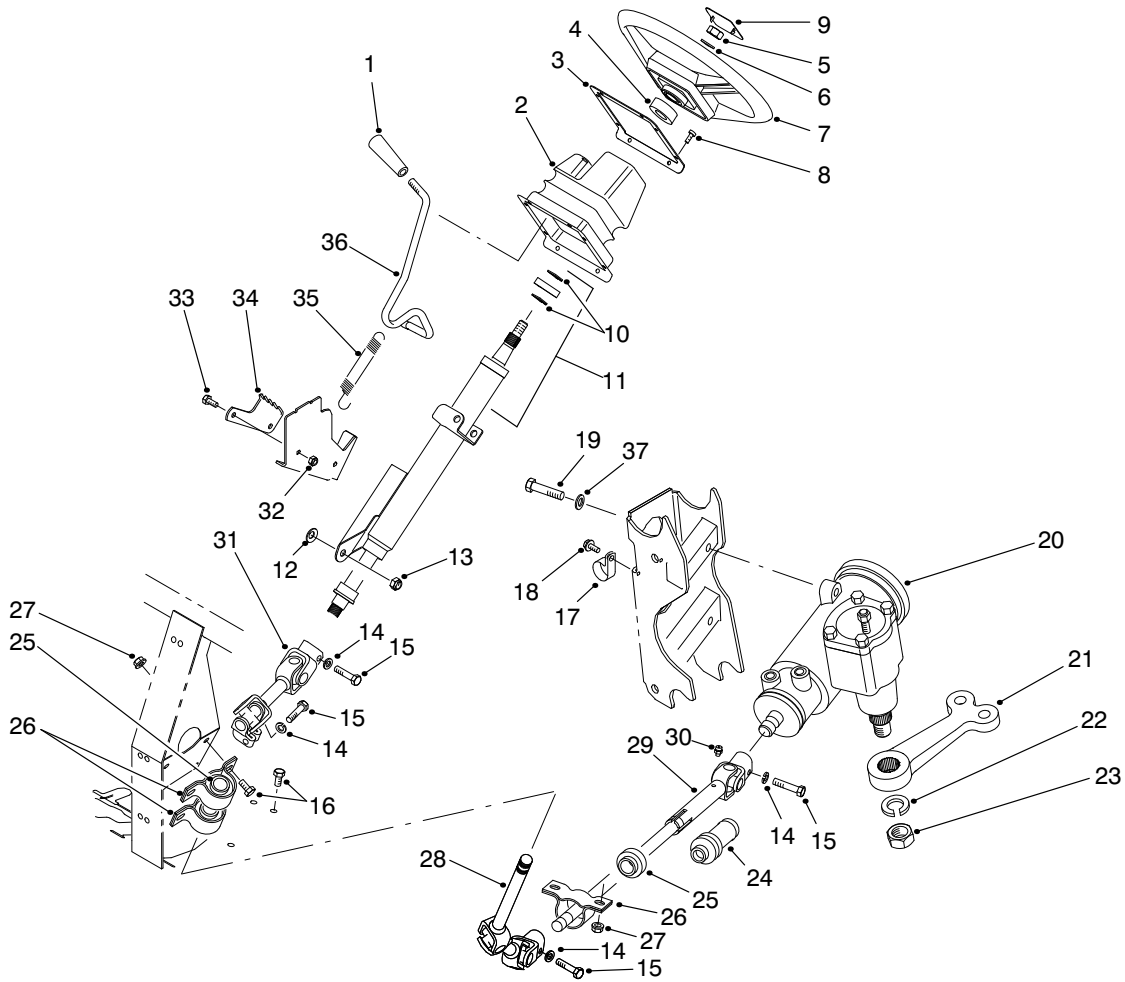

T-1584-1

STEERING LINKAGE ASSEMBLY

Ref. No.	Part No.	Description	No. Used
1	233-39	Knob	1
2	87-3460	Boot - Tilt Steering	1
3	87-4720	Plate - Steering Boot	1
4	21-9260	Spacer	1
5	3277-1	Nut - Hex.	1
6	48-8070	Washer - Flat	1
7	87-3820	Wheel - Steering	1
8	32144-116	Screw - Pan Head	8
9	87-3750	Cover - Steering Wheel	1
10	43-6550	Ring - Retaining	2
11	92-4153	Steering Column Assembly (Incl. Ref. #10)	1
12	3290-455	Washer	1
13	3296-59	Nut - Lock	1
14	3253-4	Washer - Lock	4
15	48-7740	Screw - Cap Hex. Hd.	4
16	322-2	Screw - Cap Hex. Hd.	6
17	2412-105	Clamp - R	2
18	32144-10	Screw - Self Tapping	2
19	93-7145	Screw - Cap Hex. Hd.	3
20	87-1500	Steering Gear Assembly (Incl. Ref. #22 & 23)	1

Ref. No.	Part No.	Description	No. Used
21	87-0370	Arm - Pitman	1
22	39-7420	Washer - Lock	1
23	39-7440	Nut - Lock	1
24	92-4157	Boot - Steering Shaft	1
25	87-2280	Bearing	3
26	87-3250	Mount - Bearing	3
27	32128-20	Nut - Flange	6
28	92-4155	Upper Slip Joint Assembly	1
29	92-4156	Lower Slip Joint Assembly (Incl. Ref. #24 & 30)	1
30	302-5	Fitting - Grease	1
31	92-4154	Universal Joint Assembly	1
32	3296-42	Nut - Lock	2
33	321-3	Screw - Cap Hex. Hd.	2
34	87-3610	Bracket - Detent	1
35	65-5360	Spring - Extension	1
36	87-3130	Lever - Tilt Steering	1
37	87-7480	Washer - Flat	3
*	87-3100	Lower Shaft Assembly (Incl. Ref. #24 & 28-30)	1
*	87-3120	Steering Column & Shaft (Incl. Ref. #10, 11 & 31)	1

*Not Illustrated

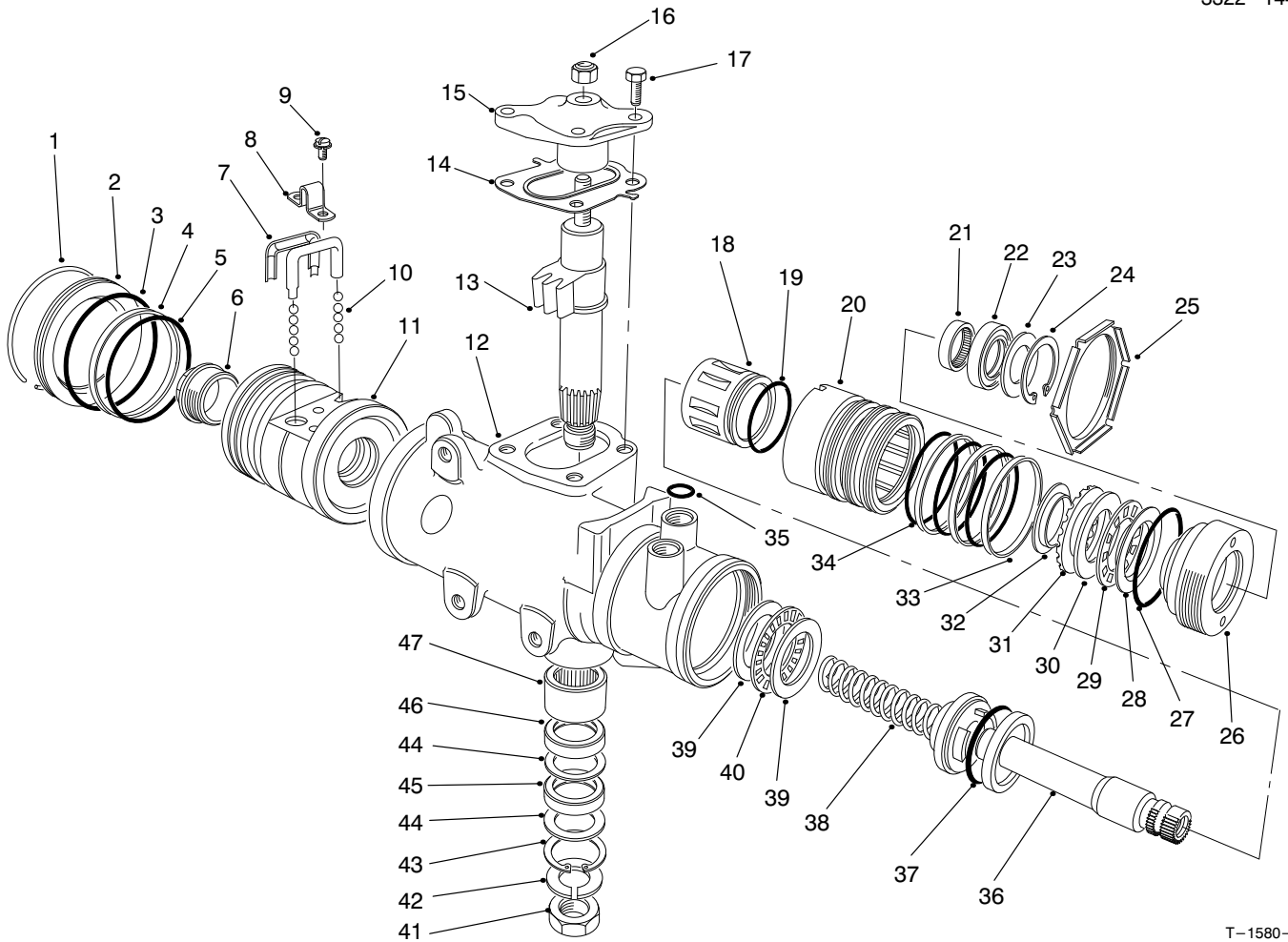

T-1580-1

STEERING GEAR ASSEMBLY NO. 87-1500

Ref. No.	Part No.	Description	No. Used
1		Ring - Retaining	1
2	92-4165	Plug - Housing End	1
3		Seal - Housing End Plug	1
4		Ring - Rack Piston	1
5		O-Ring, Rack Piston	1
6	18-4340	Plug - Rack Piston End	1
7	92-4168	Return - Guide Ball	2
8	18-4270	Clamp - Ball Return Guide	1
9	18-4260	Screw/Lockwasher Assy.	2
10	18-5190	Kit - Ball, Recirculating (Consists of 12 each of .2806 Dia. & .2812 Dia. Chrome Balls)	1
11		Nut - Rack Piston	1
12		Housing - Steering Gear	1
13		Gear - Pitman Shaft	1
14	28-8280	Seal Kit - Side Cover (Incl. Ref. #17)	1
15		Cover - Housing Side	1
16	28-8220	Nut - Lash Adjuster	1
17	28-8210	Bolt - Flange Hex. Hd.	4
18		Spool Valve	1
19		O-Ring, Spool Valve	1
20		Valve Body	1
21	92-4169	Bearing - Needle	1
22		Seal - Stub Shaft	1
23		Seal - Stub Shaft Dust	1

Ref. No.	Part No.	Description	No. Used
24		Ring - Retaining	1
25	92-4159	Nut - Adjuster Plug Lock	1
26		Plug - Adjuster	1
27	28-8200	O-Ring	1
28		Race - Upper Bearing	1
29		Bearing - Roller, Thrust	1
30		Race - Thrust Bearing	1
31		Spacer - Thrust Bearing	1
32		Retainer - Bearing	1
33		Ring - Valve Body	3
34		O-Ring	3
35	39-7310	O-Ring	3
36		Shaft - Stub	1
37		O-Ring	1
38		Worm - Steering	1
39		Race - Thrust Bearing	2
40		Bearing - Roller, Thrust	1
41	39-7440	Nut - Pitman Arm	1
42	39-7420	Washer - Lock	1
43		Ring - Retaining	1
44		Washer - Seal, Backup	2
45		Seal - Pitman Shaft	1
46		Seal - Pitman Shaft	1
47	92-4170	Bearing - Pitman Shaft	1
*	92-4161	Service Cover Assembly Housing Side (Incl. Ref. #14-17)	1

*Not Illustrated

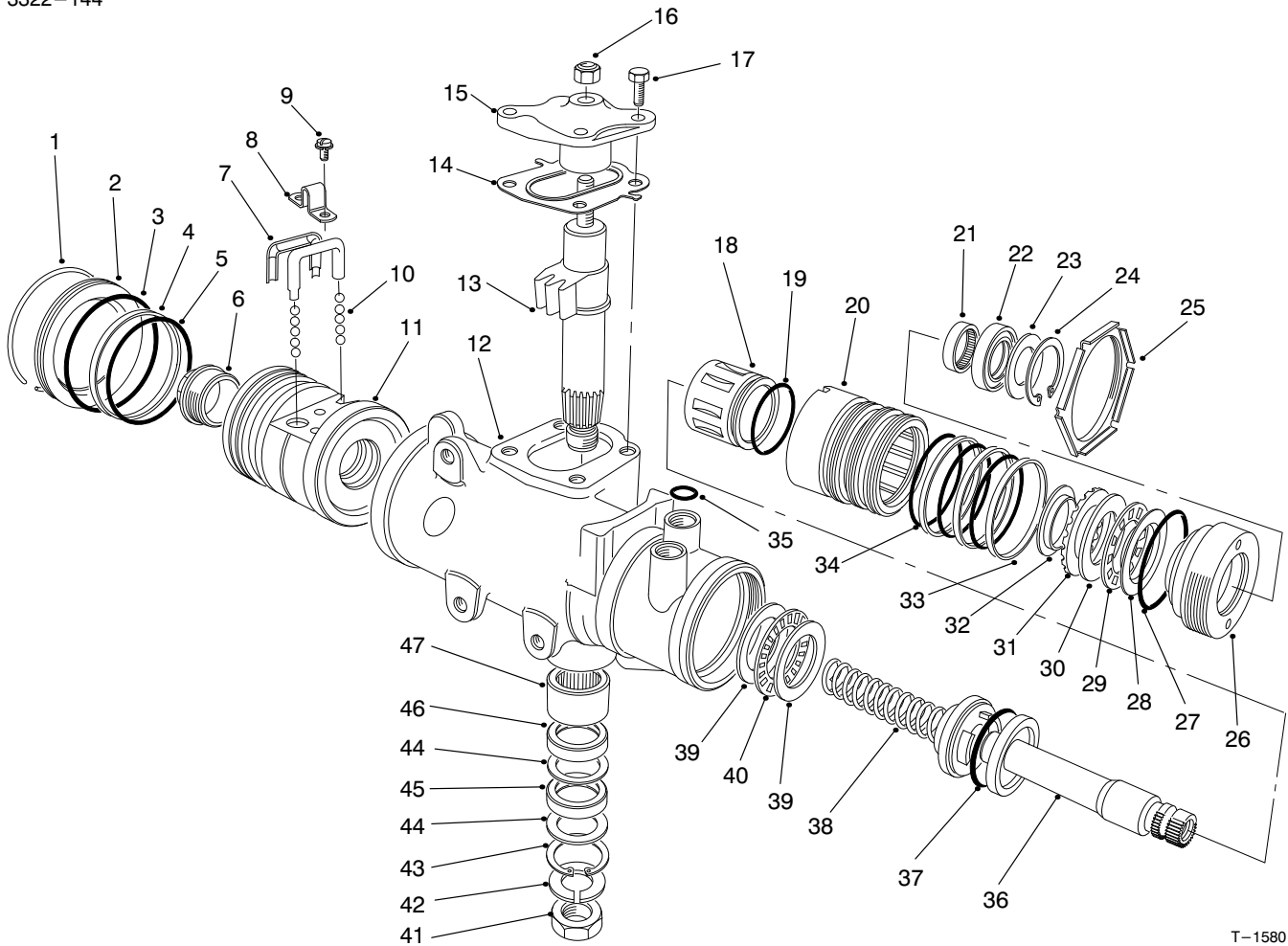

STEERING GEAR ASSEMBLY NO. 87-1500

Ref. No.	Part No.	Description	No. Used
*	28-8270	Seal Service Kit - End Plug (Incl. Ref. #1 & 3)	1
*	28-8290	Seal Service Kit Rack/Piston (Incl. Ref. #4 & 5)	1
*	18-5180	Bearing Kit - Lower Thrust (Incl. Ref. #39-40)	1
*	98-2962	Seal Kit - Pitman Shaft (Incl. Ref. #43-46)	1
*	18-5170	Seal Kit - Valve Ring (Incl. Ref. #19, 33, 34 & 37)	1
*	92-4163	Steering Housing Assembly (Incl. Ref. #12 & 43-47)	1
*	92-4167	Service Plug Assembly (Incl. Ref. #22-24 & 27)	1

Ref. No.	Part No.	Description	No. Used
*	92-4162	Pitman Shaft - Gear Service (Incl. Ref. #13-14 & 17)	1
*	92-4158	Valve Assy. - Hyd. Gear (Incl. Ref. #18-20, 33, 34, 36 & 37)	1
*	92-4160	Bearing Service Kit - Upper (Incl. Ref. #28-32)	1
*	92-4166	Rack/Piston/Nut Assembly (Incl. Ref. #1-11 & 38)	1
*	92-4164	Plug Assy. - Service Adjust. (Incl. Ref. #21-24 & 26-32)	1
*	87-1500	Steering Gear (Complete)	1

*Not Illustrated

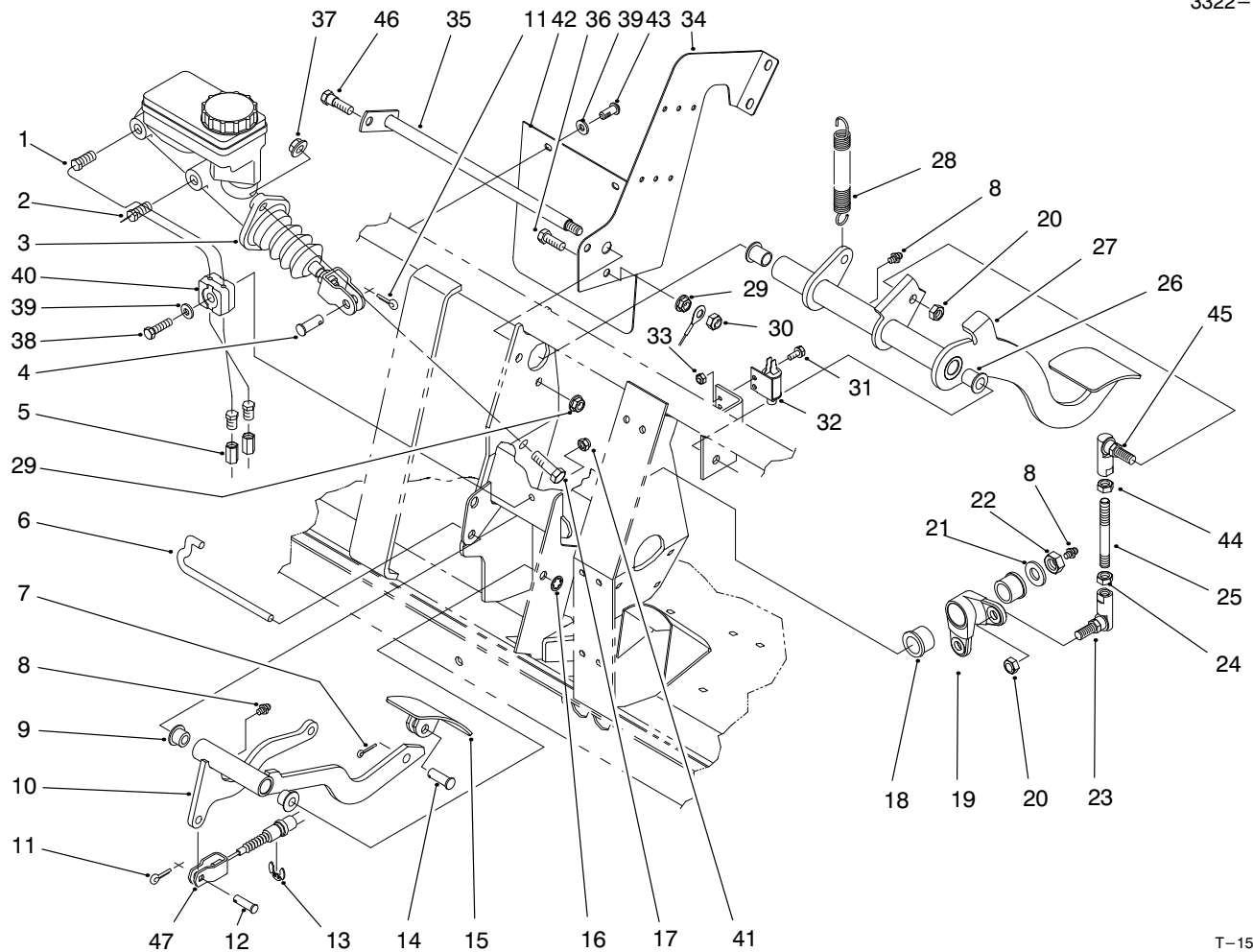

T-1585-2

BRAKE & ACCELERATOR PEDAL ASSEMBLY

Ref. No.	Part No.	Description	No. Used	Ref. No.	Part No.	Description	No. Used
1	94-3814	Tube - Hydraulic	1	25	94-5299	Rod - Link	1
2	94-3815	Tube - Hydraulic	1	26	256-155	Bushing - Flange	2
3	94-3800	Master Cylinder Assembly	1	27	93-8965	Pedal - Brake	1
4	283-2	Pin - Clevis	1	28	76-9430	Spring - Extension	1
5	87-3570	Union - Brake Line	2	29	32128-20	Nut - Flange Lock	2
6	87-2880	Shaft - Accelerator Pedal	1	30	3296-29	Nut - Lock	1
7	3272-6	Pin - Cotter	1	31	3290-321	Screw - Hex. Flange Hd.	2
8	302-5	Fitting - Grease	3	32	55-7120	Switch - Brake Light	1
9	256-259	Bushing - Flange	2	33	3296-2	Nut - Lock	2
10	93-8961	Arm - Accelerator Pedal	1	34	94-3821	Plate - Center, Frame	1
11	3272-10	Pin - Cotter	2	35	95-7394	Shaft - Brake	1
12	283-30	Pin - Clevis	1	36	322-5	Screw - Cap Hex. Hd.	1
13	32120-47	Ring - E	1	37	3290-357	Nut - Flange	2
14	283-85	Pin - Clevis	1	38	321-9	Screw - Cap Hex. Hd.	1
15	93-8969	Pedal - Accelerator	1	39	3256-22	Washer - Flat	3
16	32151-56	Ring - Retaining	1	40	87-7660	Clamp - Tube	2
17	323-7	Screw - Cap Hex. Hd.	1	41	3296-42	Nut - Lock	1
18	256-247	Bushing - Flange	2	42	94-5221	Flap - Master Cylinder	1
19	94-5223	Bell Crank	1	43	87-6620	Screw - Torx Pan Hd.	2
20	3296-6	Nut - Lock	2	44	3220-16	Nut - Hex. Jam	1
21	3256-26	Washer - Flat	1	45	68-3841	Ball Joint Assembly	1
22	3296-23	Nut - Lock	1	46	28-0540	Bolt - Shoulder	1
23	68-3840	Ball Joint	1	47	94-3834	Cable - Accelerator	1
24	3220-3	Nut - Hex. Jam	1				

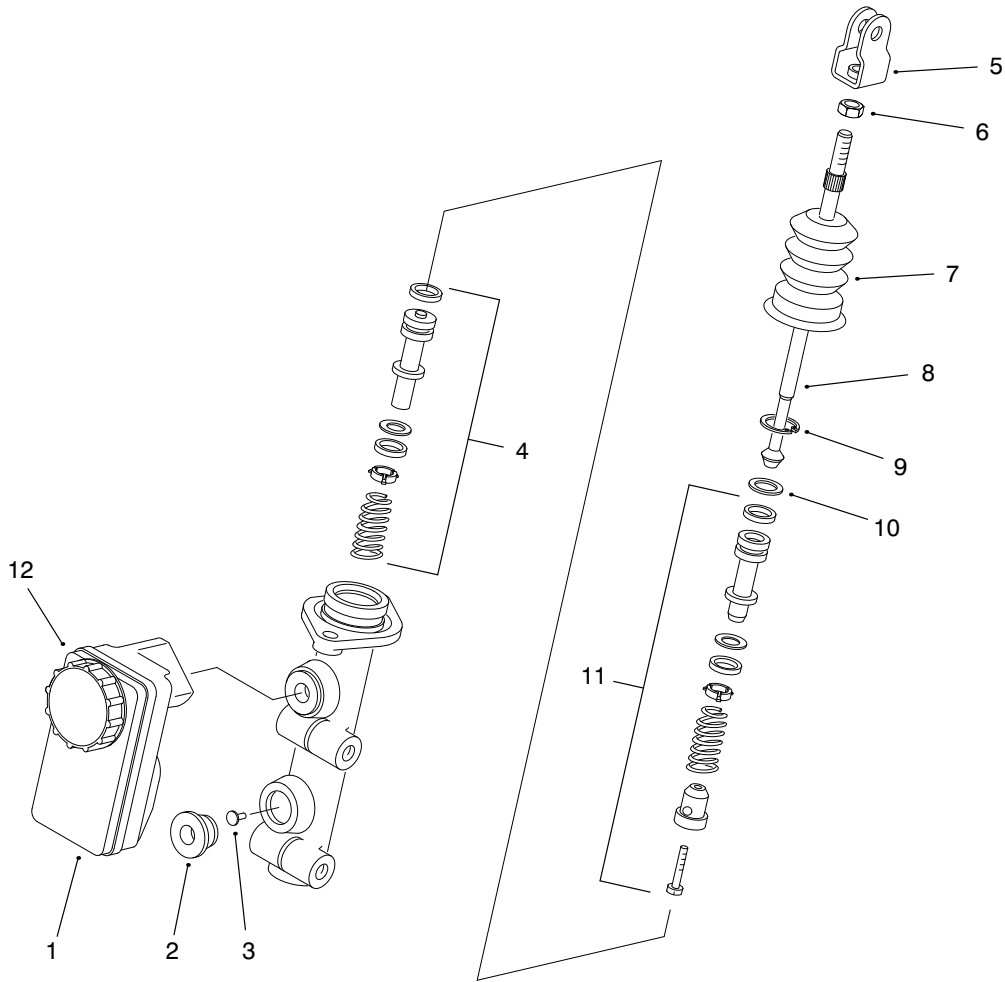

T-2339-1

MASTER BRAKE CYLINDER NO. 94-3800

Ref. No.	Part No.	Description	No. Used
1	87-3040	Reservoir - Master Cylinder (Incl. Ref. #12)	1
2	93-8971	Seal	2
3	92-4103	Pin - Stop	1
4	92-4102	Secondary Piston Assembly	1
5	92-4110	Clevis	1
6	21-0360	Nut	1

Ref. No.	Part No.	Description	No. Used
7	94-5209	Dust Cover	1
8	94-5210	Rod - Push	1
9	92-4109	Circlip	1
10	92-4108	Washer - Retainer	1
11	92-4101	Primary Piston Assembly	1
12	92-4112	Cap Assembly	1

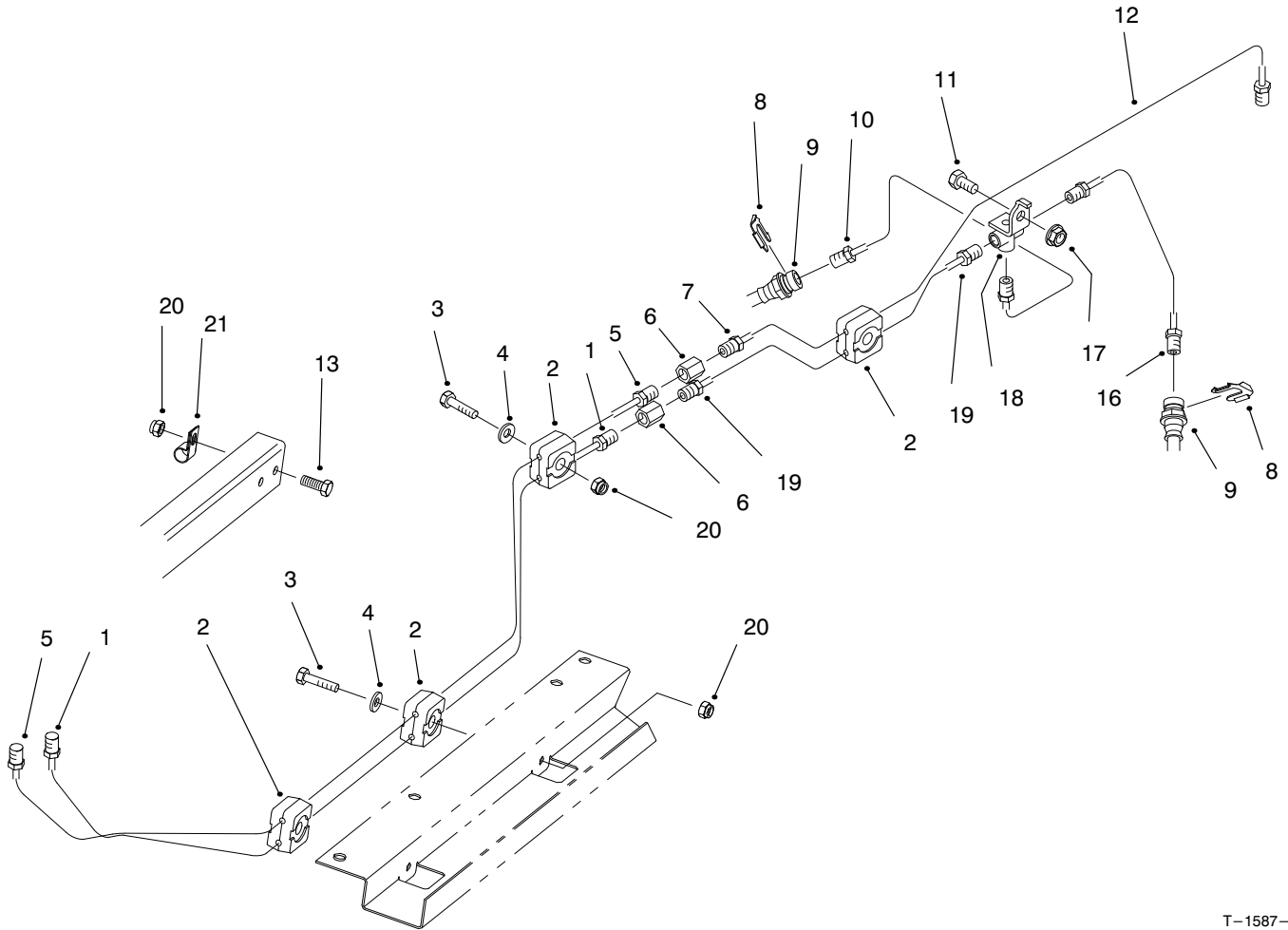

T-1587-1

HYDRAULIC BRAKE LINE ROUTING ASSEMBLY

Ref. No.	Part No.	Description	No. Used
1	94-3820	Tube - Brake Front	1
2	87-7660	Clamp - Brake Line	8
3	321-9	Screw - Cap Hex. Hd.	4
4	3256-22	Washer - Flat	4
5	94-3819	Tube - Brake Rear	1
6	87-3570	Fitting - Union	2
8	87-3580	Retainer - Brake Hose	2
9	93-7123	Hose - Brake Front	2
10	93-7081	Tube - Brake Front RH	1

Ref. No.	Part No.	Description	No. Used
11	322-2	Screw - Cap Hex. Hd.	1
12	94-3842	Tube - Brake Rear	1
13	321-4	Screw - Cap Hex. Hd.	1
16	93-7082	Tube - Brake Front LH	1
17	32128-20	Nut - Flange	1
18	87-3560	Tee - Brake Line	1
19	93-7085	Tube - Brake Front	1
20	3296-42	Nut - Lock	5
21	2412-89	Clamp - R	1

HYDRAULIC SCHEMATIC

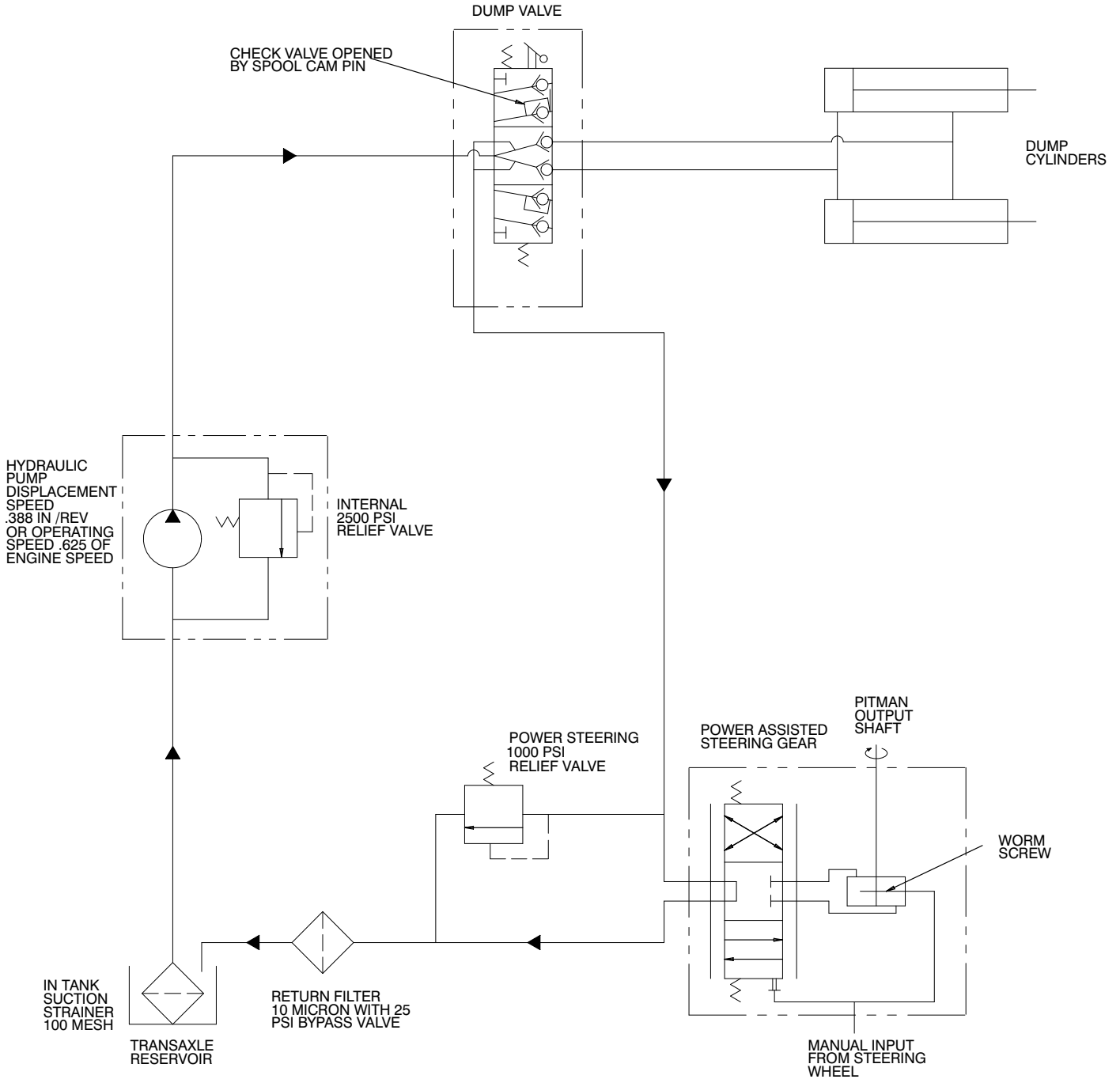

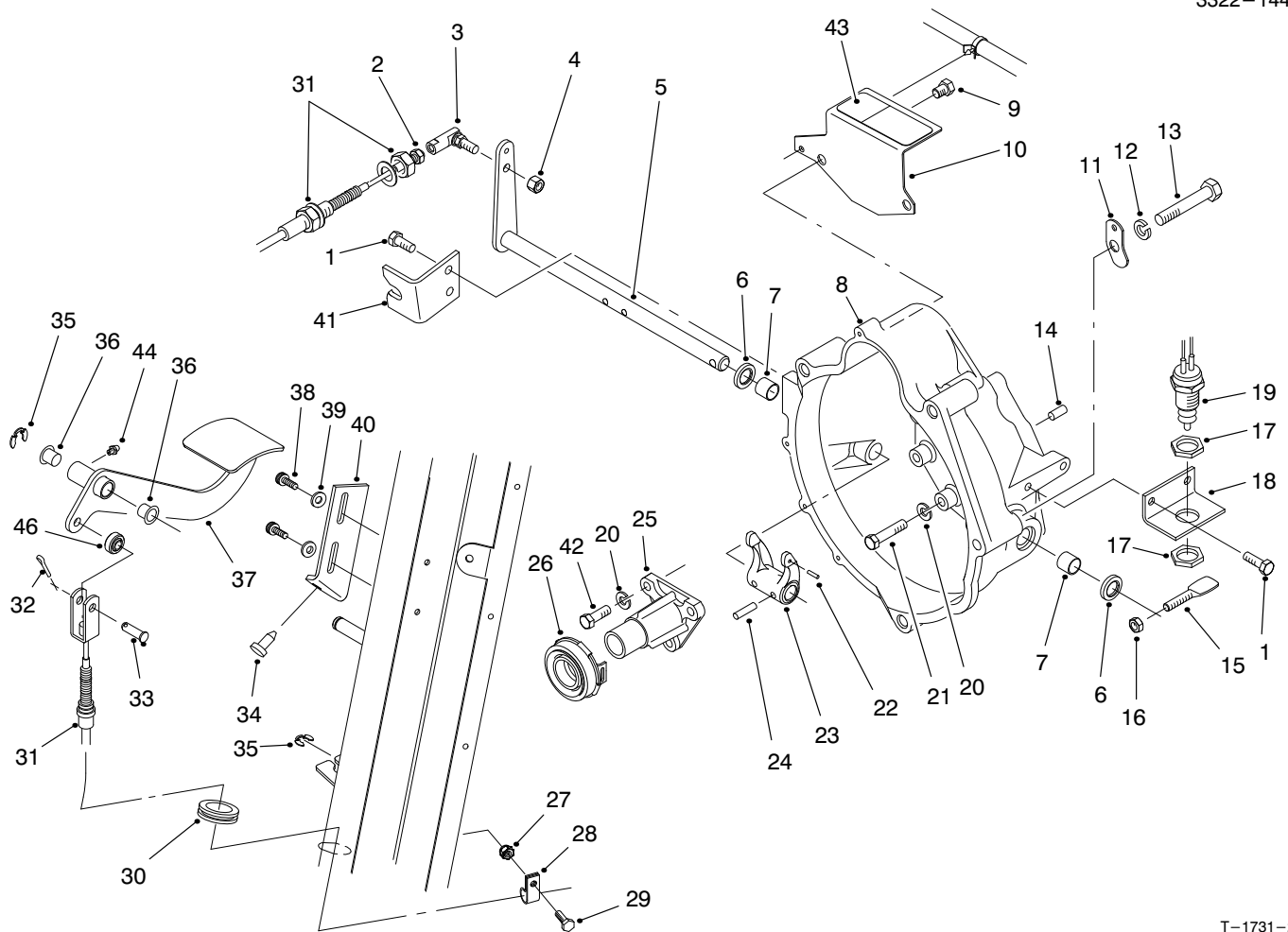

T-1731-2

CLUTCH LINKAGE ASSEMBLY

Ref. No.	Part No.	Description	No. Used	Ref. No.	Part No.	Description	No. Used
1	33114-020	Screw - Cap Hex. Hd.	4	24	32121-24	Pin - Roll	2
2	3220-2	Nut - Jam	1	25	87-5320	Guide - Release	1
3	2411-33	Joint - Ball	1	26	87-2100	Bearing - Release	1
4	3296-4	Nut - Lock	1	27	32128-33	Nut - Flange Lock	1
5	87-5290	Shaft - Release	1	28	2412-89	Clamp - R	1
6	87-1920	Seal - Shaft	2	29	321-4	Screw - Cap Hex. Hd.	1
7	87-3770	Bushing - Sleeve	2	30	240-5	Grommet	1
8	93-7121	Housing - Bell	1	31	99-1201	Clutch Cable Assembly (Incl. Ref. #2)	1
9	60-9920	Screw - Cap Hex. Hd.	2	32	3272-10	Pin - Cotter	1
10	87-8790	Starter Cover Plate Assembly (Incl. Ref. #43)	1	33	283-75	Pin - Clevis	1
11	87-6410	Bracket - Harness	1	34	87-8460	Bumper	1
12	3253-22	Washer - Lock	4	35	32120-47	Ring - E	2
13	56-2150	Screw - Cap Hex. Hd.	4	36	256-156	Bushing - Flange	2
14	87-1910	Pin - Alignment	2	37	99-1199	Pedal - Clutch	1
15	87-5360	Lever	1	38	87-6620	Screw - Torx Pan Hd.	2
16	3296-29	Nut - Lock	1	39	3256-22	Washer - Flat	2
17	3218-20	Nut - Jam	2	40	87-8710	Tab - Clutch	1
18	87-5350	Bracket - Switch	1	41	87-8471	Bracket - Clutch	1
19	87-5490	Switch - Neutral	1	42	33114-025	Screw - Cap Hex. Hd.	3
20	42-9850	Washer - Lock	12	43	66-6840	Decal - Hot Surface	1
21	33114-040	Screw - Cap Hex. Hd.	9	44	302-5	Fitting - Grease	1
22	32121-7	Pin - Roll	1	46	99-1202	Rod End	1
23	87-5300	Fork - Clutch	1				

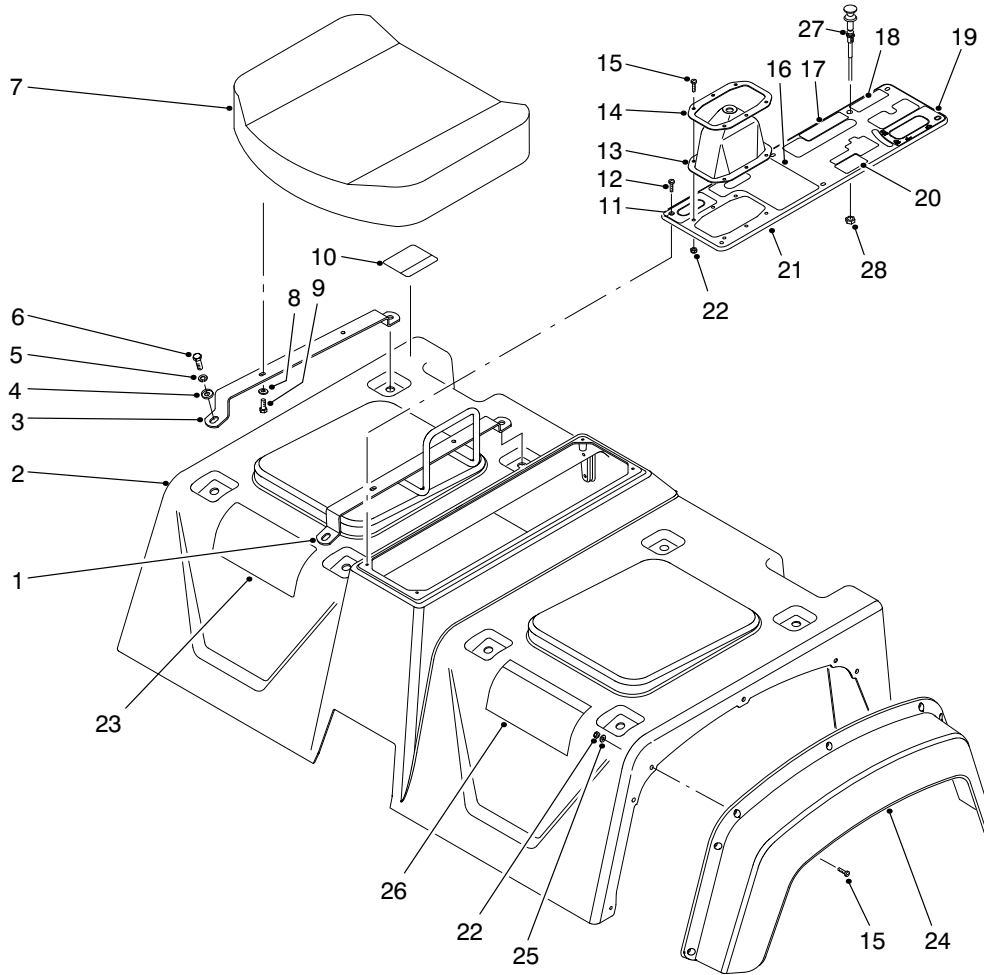

T-1589-2

SEAT BASE ASSEMBLY

Ref. No.	Part No.	Description	No. Used
1	87-6890	Hold - Hand	1
2	87-7070	Skirt Assembly (Incl. Ref. #10 & 26)	1
3	87-3800	Bracket - Seat Bottom	3
4	3256-23	Washer - Flat	4
5	3253-4	Washer - Lock	8
6	322-5	Screw - Cap Hex. Hd.	8
7	87-5060	Cushion - Seat Bottom	2
8	3256-22	Washer - Flat	8
9	321-4	Screw - Cap Hex. Hd.	8
10	87-5930	Decal - Caution	1
11	87-5960	Decal - Axle Range	1
12	32144-52	Screw - Hex. Hd.	6
13	87-8620	Boot - Shift	1
14	87-3760	Plate - Shift Boot	1

Ref. No.	Part No.	Description	No. Used
15	3250-13	Screw - Hex. Hd.	20
16	87-5970	Decal - PTO	1
17	87-6000	Decal - Differential Lock	1
18	92-2609	Decal - Remote Hydraulics	1
19	87-6010	Decal - Dump Hydraulics	1
20	87-6020	Decal - Parking Brake	1
21	87-8080	Console Plate Assembly (Incl. Ref. #11 & 16-20)	1
22	3296-2	Nut - Lock	20
23	93-8990	Decal - Quick Reference	1
24	87-9480	Fender - Front	2
25	3256-61	Washer - Flat	14
26	87-5920	Decal - Danger	1
27	87-8060	Choke Control Assembly	1
28	3220-3	Nut - Jam	1

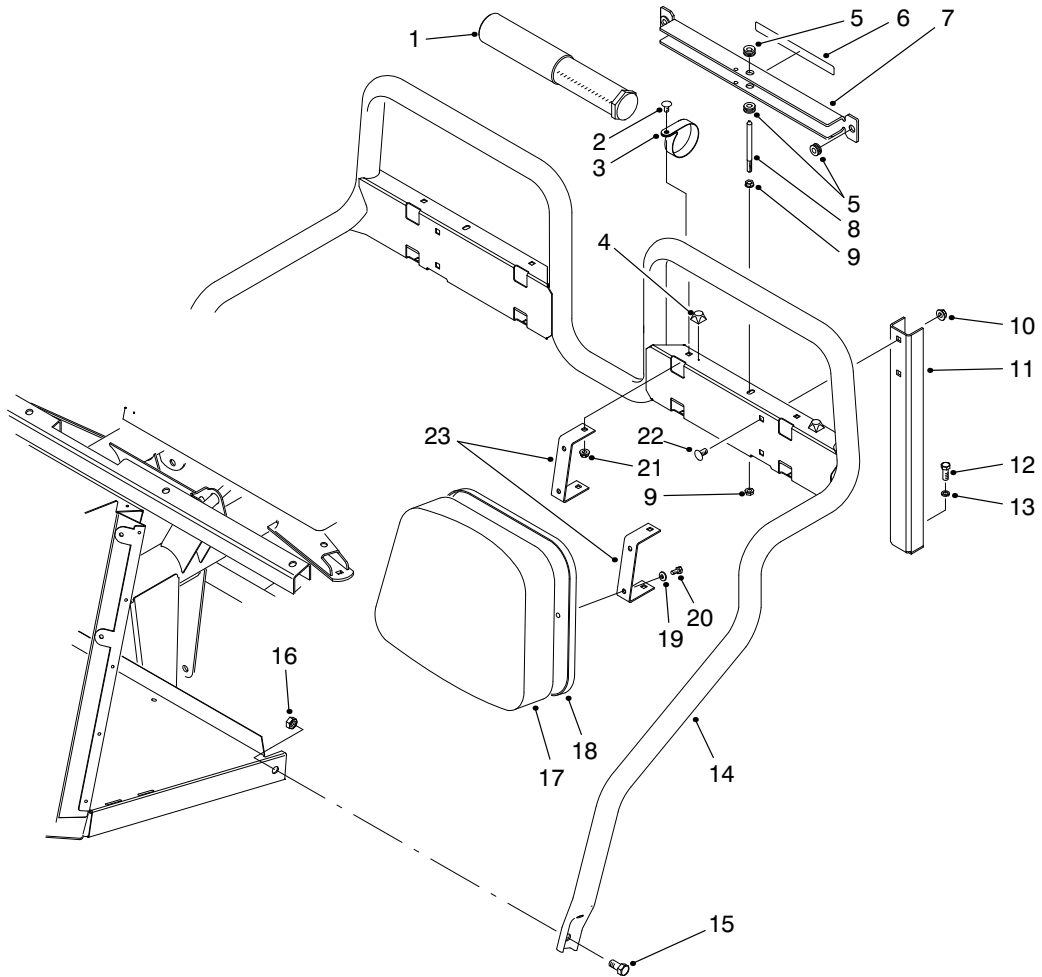

T-1779-1

SEAT BACK ASSEMBLY

Ref. No.	Part No.	Description	No. Used	Ref. No.	Part No.	Description	No. Used
1	74-0720	Tube - Manual	1	12	323-6	Screw - Cap Hex. Hd.	2
2	3230-18	Bolt - Carriage	2	13	3253-21	Washer - Lock	2
3	2412-133	R-Clamp	2	14	87-6170	Frame - Seat	1
4	111071	Bumper	2	15	325-4	Screw - Cap Hex. Hd.	2
5	92-5972	Grommet	4	16	3296-23	Nut - Lock	2
6	87-7930	Decal - Danger	1	17	87-6290	Cushion - Seat Back	2
7	87-7950	Bed Support Assembly (Incl. Ref. #5 & 6)	1	18	87-6280	Plate - Seat Back	2
8	87-7940	Stud	1	19	3256-22	Washer - Flat	8
9	32128-44	Nut - Flange Lock	2	20	321-4	Screw - Cap Hex. Hd.	8
10	3290-357	Nut - Flange Lock	4	21	32128-20	Nut - Flange Lock	8
11	87-2510	Bracket - Seat Frame	2	22	3231-21	Bolt - Carriage	4
				23	87-6240	Bracket - Seat Back	4

3322-144

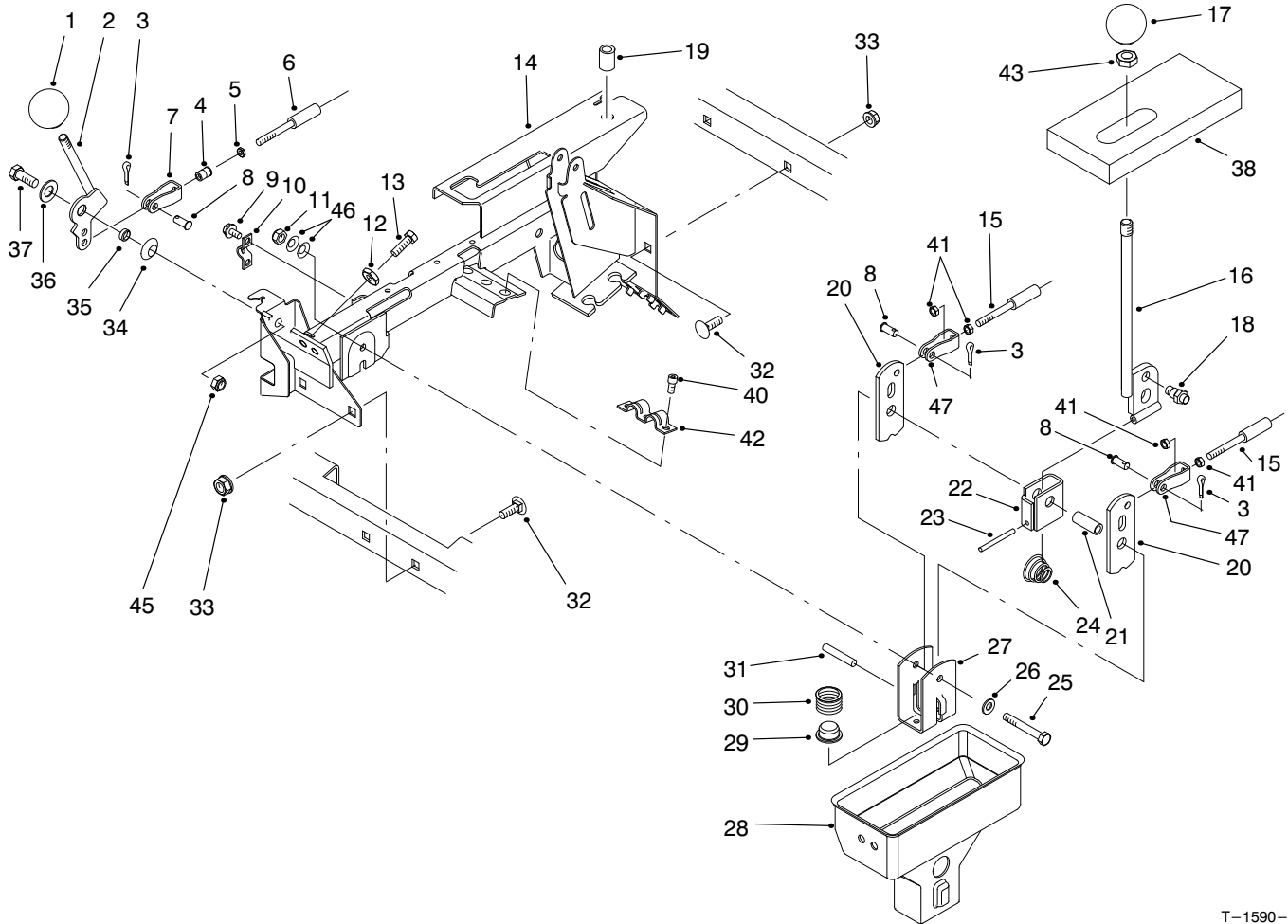

T-1590-1

HI-LO & SHIFT LEVER ASSEMBLIES

Ref. No.	Part No.	Description	No. Used
1	233-37	Knob	1
2	87-4350	Lever - Hi-Lo	1
3	3272-6	Pin - Cotter	3
4	32148-15	Insert - Threaded	1
5	3219-14	Nut	1
6	87-4420	Hi-Lo Cable Assembly (Incl. Ref. #5)	1
7	87-7160	Cable Clevis Assembly (Incl. Ref. #4)	3
8	283-62	Pin - Clevis	3
9	32144-4	Screw - Hex. Washer Hd.	2
10	87-4340	Clamp - Cable	1
11	3296-58	Nut - Lock	2
12	3220-3	Nut - Jam	2
13	3211-8	Screw - Cap Hex. Hd.	2
14	94-5202	Lever Support Assembly (Incl. Ref. #19)	1
15	87-4260	Cable Assembly (Incl. Ref. #41)	2
16	87-2040	Lever - Shift	1
17	87-6720	Knob	1
18	87-3650	Pin - Shift	1
19	32148-7	Nut - Clinch	2
20	87-3540	Link - Shift	2

Ref. No.	Part No.	Description	No. Used
21	87-2520	Tube - Pivot	1
22	87-6040	Bracket - Shifter	1
23	32121-48	Pin - Roll	1
24	87-2900	Spring - Compression	1
25	322-12	Screw - Cap Hex. Hd.	1
26	87-8640	Washer - Flat	1
27	87-3520	Clevis	1
28	87-2260	Boot - Shift Lower	1
29	87-3530	Button - Shifter	1
30	87-3660	Spring - Compression	1
31	3290-507	Pin - Dowel	1
32	3231-21	Bolt - Carriage	4
33	3290-357	Nut - Flange Lock	4
34	3290-221	Washer - Spring	1
35	76-9100	Spacer - Hi-Lo Lever	1
36	49-9150	Washer - Flat	1
37	323-6	Screw - Cap Hex. Hd.	1
38	87-6570	Foam - Seal	1
40	65-5220	Screw - Hex. Socket Hd.	3
41	3220-1	Nut - Jam	4
42	87-4960	Clamp - Cable	1
43	3218-18	Nut - Jam	1
45	3296-39	Nut - Lock	1
46	3290-456	Washer - Belleville	2

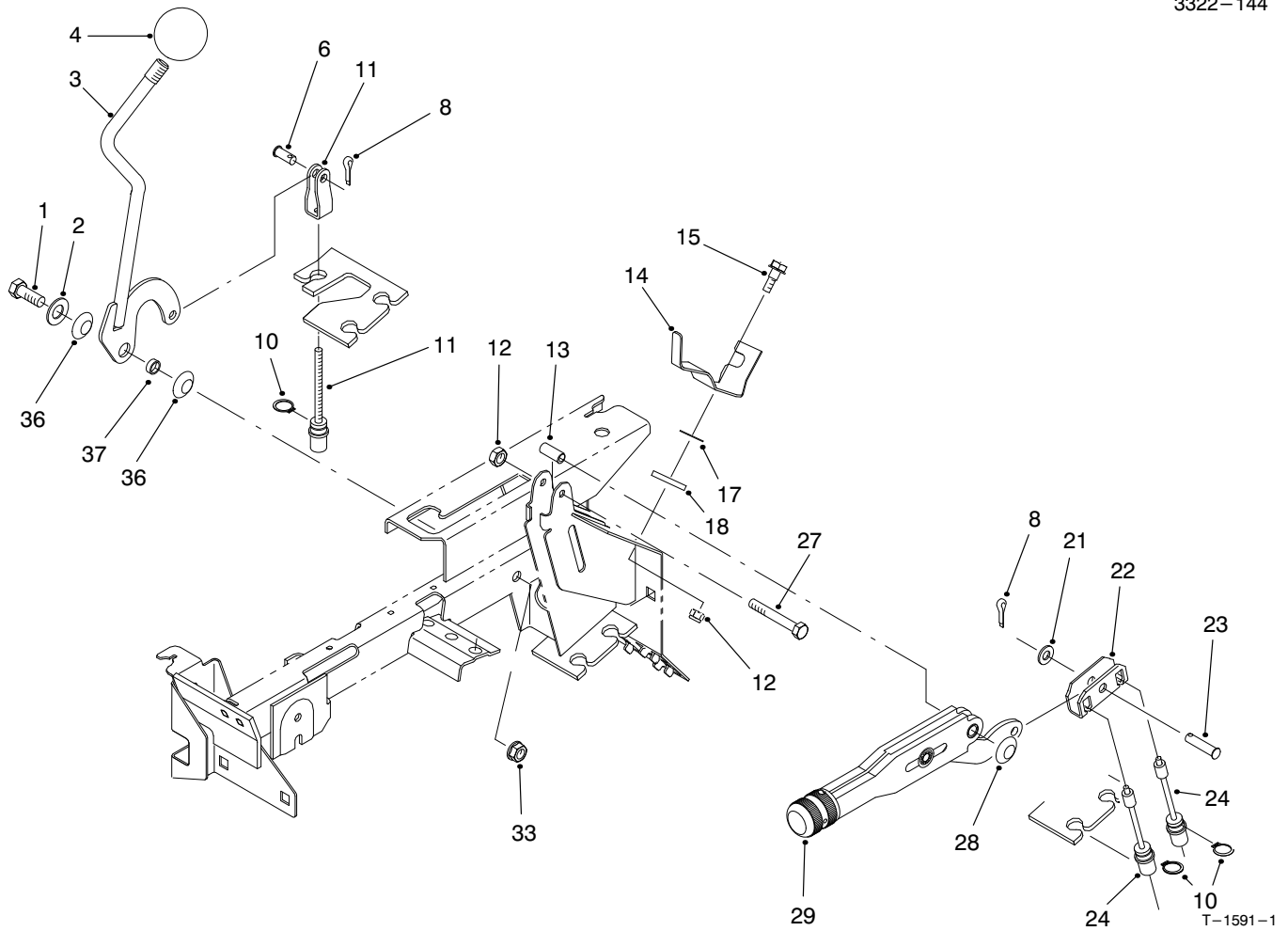

DIFFERENTIAL LOCK & PARKING BRAKE ASSEMBLIES

Ref. No.	Part No.	Description	No. Used
1	323-6	Screw - Cap Hex. Hd.	1
2	49-9150	Washer - Flat	1
3	87-5030	Lever - Differential Lock	1
4	233-48	Knob	1
6	283-62	Pin - Clevis	1
8	3272-6	Pin - Cotter	2
10	32120-47	Ring - Retaining	3
11	87-4460	Differential Lock Cable	1
12	3296-42	Nut - Lock	2
13	87-4710	Spacer - Parking Brake	1
14	87-6640	Lever - Dump Stop	1
15	42-3560	Screw - Shoulder	1

Ref. No.	Part No.	Description	No. Used
17	3290-478	Washer - Belleville	1
18	71-5320	Washer - Flat	1
21	3256-23	Washer - Flat	1
22	87-3480	Plate - Brake Equalizer	1
23	94-3829	Pin - Clevis	1
24	87-8240	Cable - Parking Brake	2
27	321-9	Screw - Cap Hex. Hd.	1
28	3290-477	Washer - Curved	1
29	87-2710	Lever - Parking Brake	1
33	3296-39	Nut - Lock	1
36	3290-221	Washer - Spring	2
37	76-2290	Spacer	1

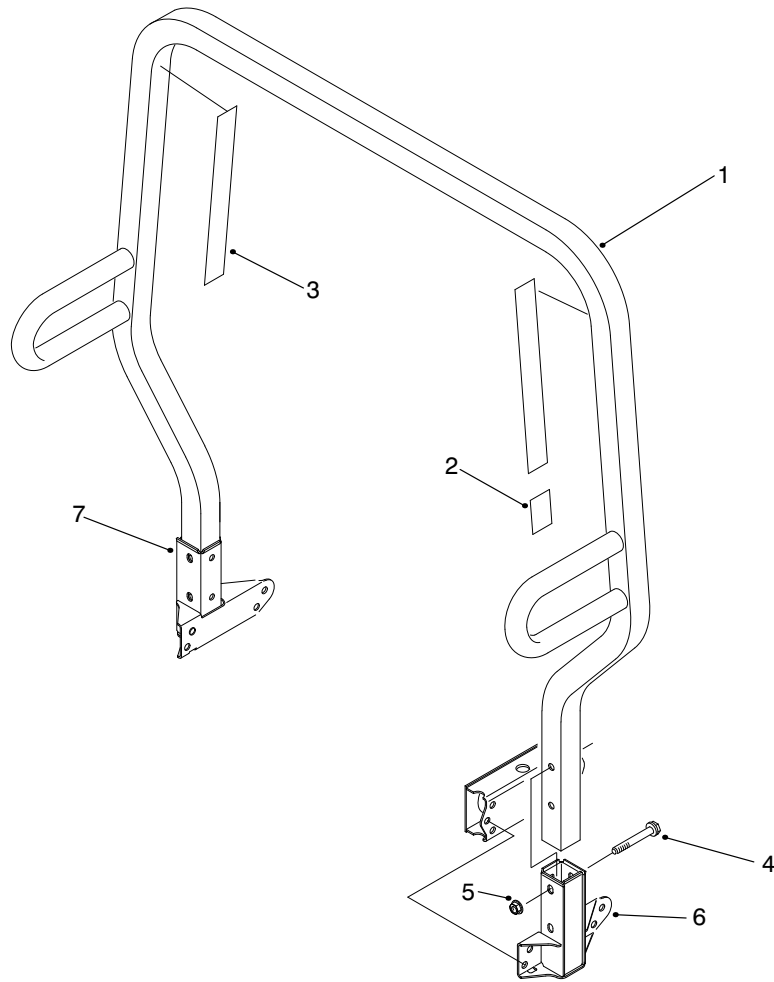

T-1592-1

R.O.P.S. ASSEMBLY

Ref. No.	Part No.	Description	No. Used
1	87-7090	R.O.P.S. Frame Assembly (Incl. Ref. #2 & 3)	1
2	87-5940	Decal - Rollover	1
3	87-5980	Decal - ROPS	2

Ref. No.	Part No.	Description	No. Used
4	3234-40	Screw - Hex. Flange Hd.	4
5	32128-23	Nut - Flange Lock	4
6	87-6950	Receiver - LH	1
7	87-6960	Receiver - RH	1

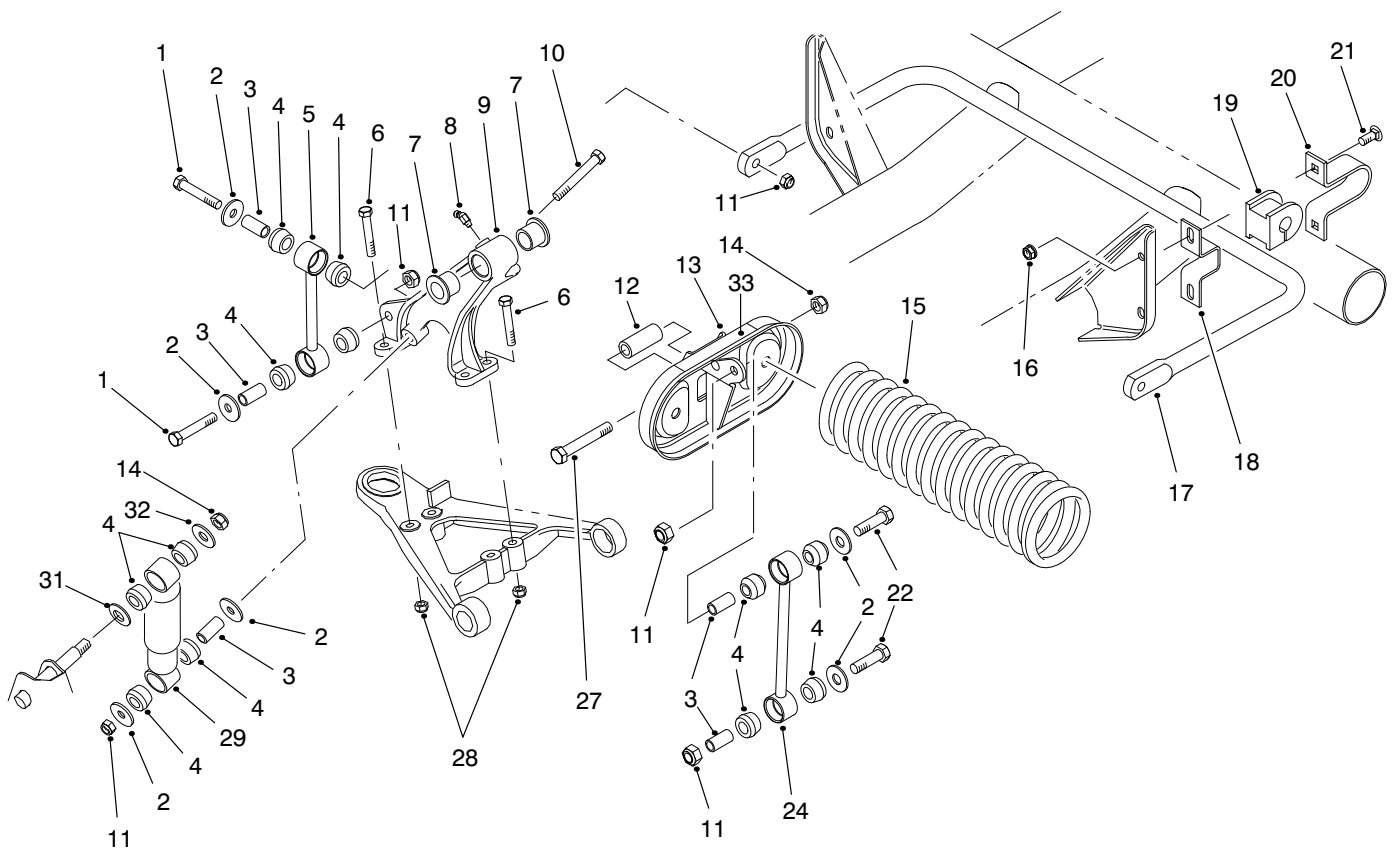

T-1593-1

FRONT SUSPENSION ASSEMBLY

Ref. No.	Part No.	Description	No. Used	Ref. No.	Part No.	Description	No. Used
1	324-10	Screw - Cap Hex. Hd.	4	15	87-0690	Spring - Compression	2
2	87-5330	Washer	12	16	3290-357	Nut - Flange Lock	4
3	87-3600	Spacer	10	17	87-3850	Bar - Anti-Sway	1
4	87-3920	Bushing - Rubber	24	18	87-3890	Bracket - Anti-Sway Bar	2
5	87-3860	Link - Anti-Sway Bar	2	19	87-3910	Bushing - Anti-Sway Bar	2
6	323-12	Screw - Cap Hex. Hd.	8	20	87-4010	Clamp - Anti-Sway Bar	2
7	33-3090	Bushing - Flange	4	21	3231-25	Bolt - Carriage	4
8	302-11	Fitting - Grease	2	22	324-9	Screw - Cap Hex. Hd.	4
9	87-0150	Tower - Control Arm RH	1	24	87-2480	Link - Stabilizer	2
*	87-0160	Tower - Control Arm LH	1	27	325-13	Screw - Cap Hex. Hd.	4
10	324-13	Screw - Cap Hex. Hd.	2	28	3296-39	Nut - Lock	8
11	3296-48	Nut - Lock	10	29	87-3110	Absorber - Shock	2
12	87-2500	Sleeve - Spring Pivot	2	31	3256-27	Washer - Flat	2
13	87-7150	Spring Cradle Assembly (Incl. Ref. #33)	2	32	3256-6	Washer - Flat	2
14	3296-23	Nut - Lock	4	33	44-0760	Decal - Warning	2

*Not Illustrated

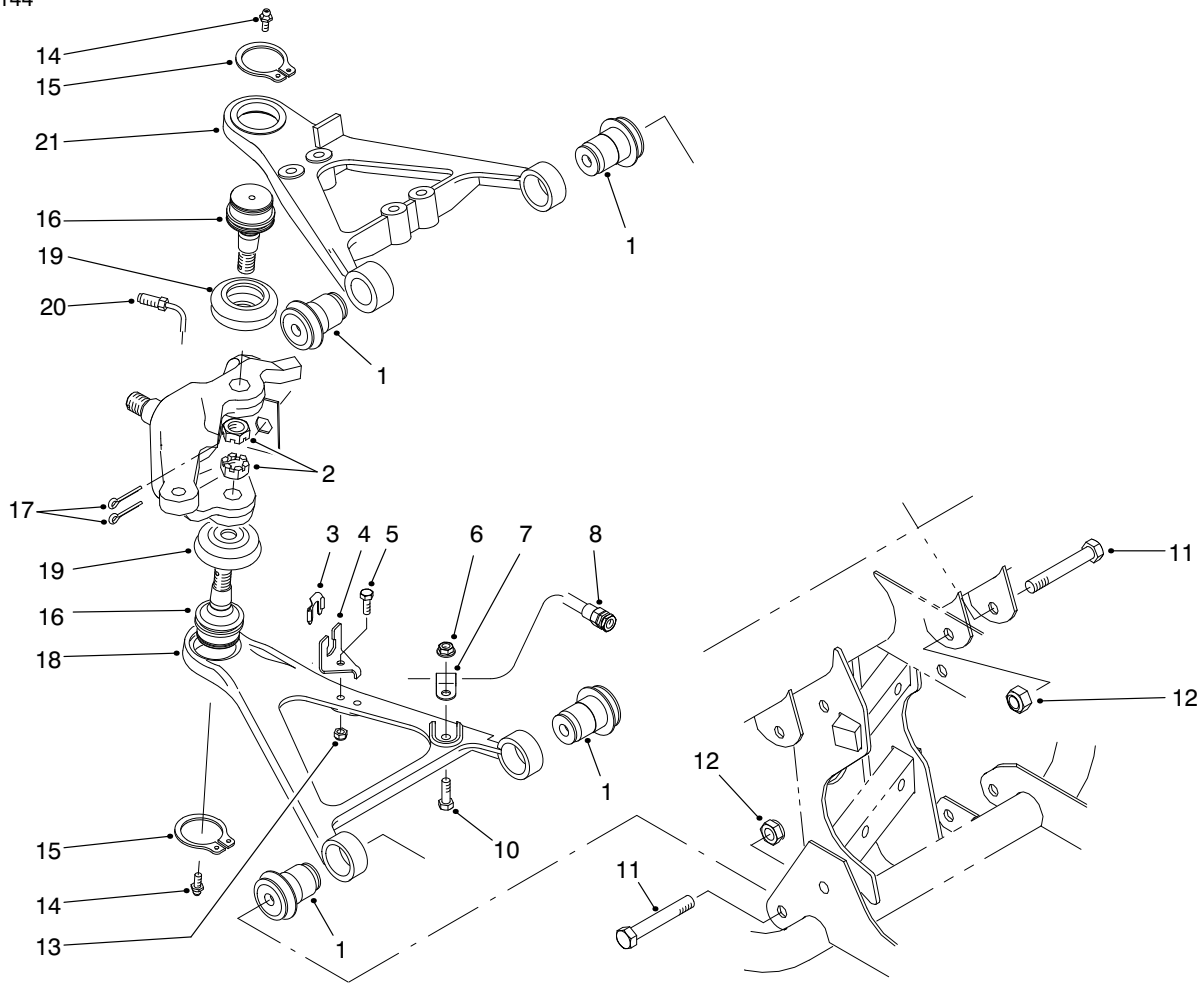

T-1594-1

FRONT SUSPENSION CONTROL ARM ASSEMBLY

Ref. No.	Part No.	Description	No. Used
1	87-1450	Bushing - Rubber	8
2	32136-2	Nut - Slotted	4
3	87-3580	Retainer - Brake Hose	2
4	87-2870	Bracket - Brake Hose	2
5	321-6	Screw - Cap Hex. Hd.	2
6	32128-20	Nut - Flange Lock	2
7	2412-10	Clamp - R	2
8	93-7123	Hose - Brake Front	2
10	322-5	Screw - Cap Hex. Hd.	2
11	325-13	Screw - Cap Hex. Hd.	8
12	3296-23	Nut - Flange Lock	8
13	3296-42	Nut - Lock	2

Ref. No.	Part No.	Description	No. Used
14	302-5	Fitting - Grease	4
15	32151-104	Ring - Snap	4
16	87-1430	Joint - Ball	4
17	3272-12	Pin - Cotter	4
18	87-0210	Arm - Control Lower RH	1
*	87-0220	Arm - Control Lower LH	1
19	87-2420	Boot	4
20	87-2800	Tube - Brake RH	1
*	87-2790	Tube - Brake LH	1
21	93-7135	Arm - Control Upper RH	1
*	93-7133	Arm - Control Upper LH	1

*Not Illustrated

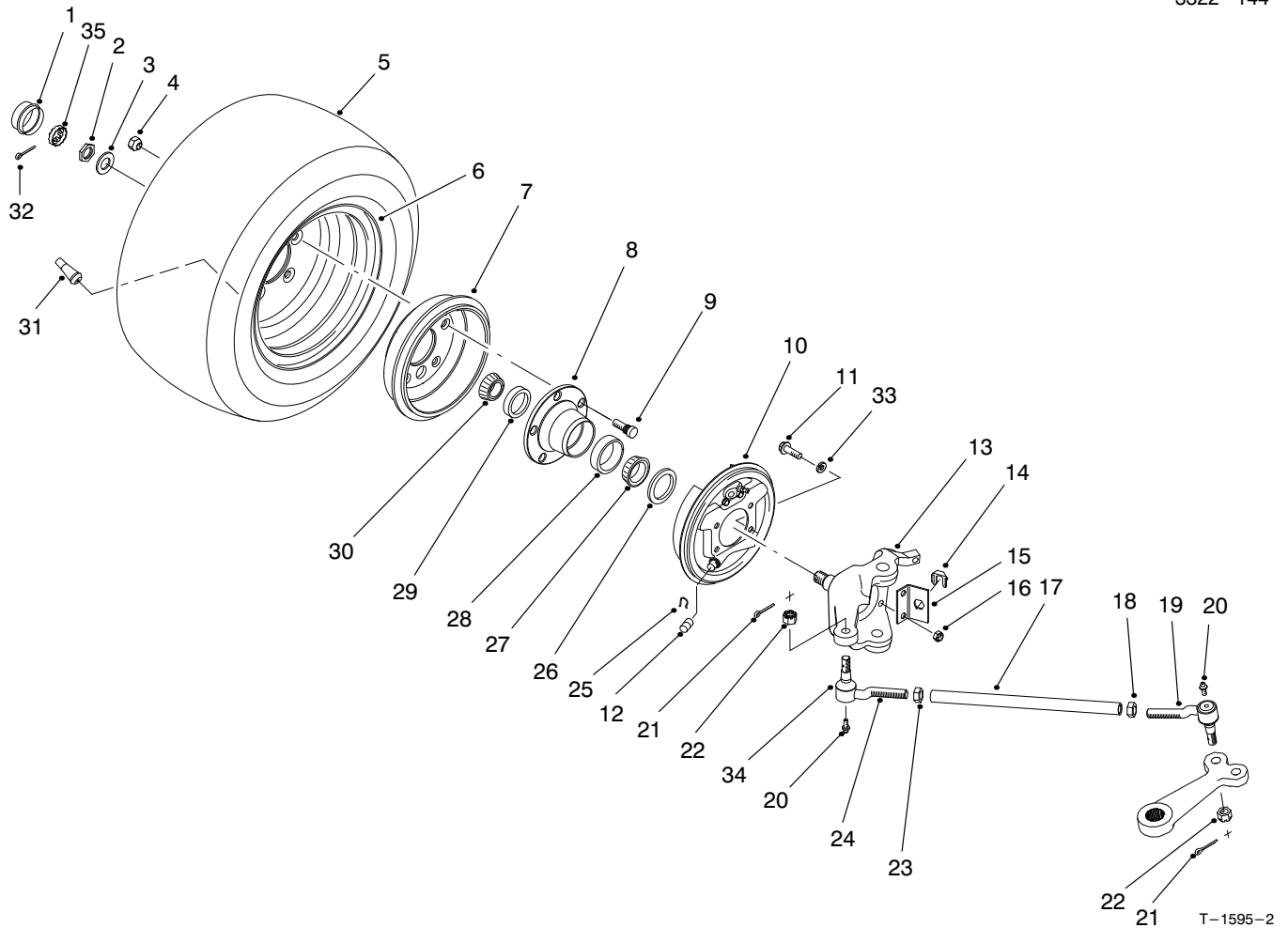

FRONT WHEEL ASSEMBLY

Ref. No.	Part No.	Description	No. Used
1	241-119	Cap Dust	2
2	32136-5	Nut Slotted	2
3	3256-28	Washer - Flat	2
4	23-7270	Nut - Lug	10
5	94-5261	Tire	2
*	Optional	Tire - Hard Surface & Traction Options (See Dealer/Distributor for Tire Selection Guide)	2
6	87-5720	Rim	2
7	87-0270	Drum - Brake	2
8	87-5560	Hub - Wheel	2
9	87-8730	Stud - Drive	10
10	87-3010	Brake Assembly - RH	1
*	87-3020	Brake Assembly - LH	1
11	323-8	Screw - Hex. Flange Hd.	8
12	87-3450	Plug	2
13	87-5520	Spindle - RH	1
*	87-5540	Spindle - LH	1
14	87-3580	Retainer	2
15	87-2820	Bracket - Hose	2
16	3296-39	Nut - Lock	8
17	87-2410	Rod - Tie	2
18	3218-21	Nut - Jam	2

Ref. No.	Part No.	Description	No. Used
19	87-1470	Rod End Assy. - LH Thread (Incl. Ref. # 20-22 & 34)	2
*	94-3804	Rod End Assy. - LH Thread Heavy Duty (Optional)	2
20	302-5	Fitting - Grease	4
21	3272-12	Pin - Cotter	4
22	32136-3	Nut - Slotted	4
23	3220-11	Nut - Jam	2
24	87-1480	Rod End Assy. - RH Thread (Incl. Ref. #20-22 & 34)	2
*	94-3807	Rod End Assy. - RH Thread Heavy Duty (Optional)	2
25	87-3310	Clip - Brake Cable	2
26	87-3590	Seal - Bearing	2
27	254-106	Cone - Bearing	2
28	254-107	Cup - Bearing	2
29	254-72	Cup - Bearing	2
30	254-94	Cone - Bearing	2
31	232-27	Stem - Valve	2
32	3272-12	Pin - Cotter	2
33	3253-21	Washer - Lock	8
34		Seal - Rod	4
35	93-0307	Nut - Retainer	2
*	87-5340	Seal Kit - Tie Rod End (Incl. Ref. #20-22 & 34)	1

*Not Illustrated

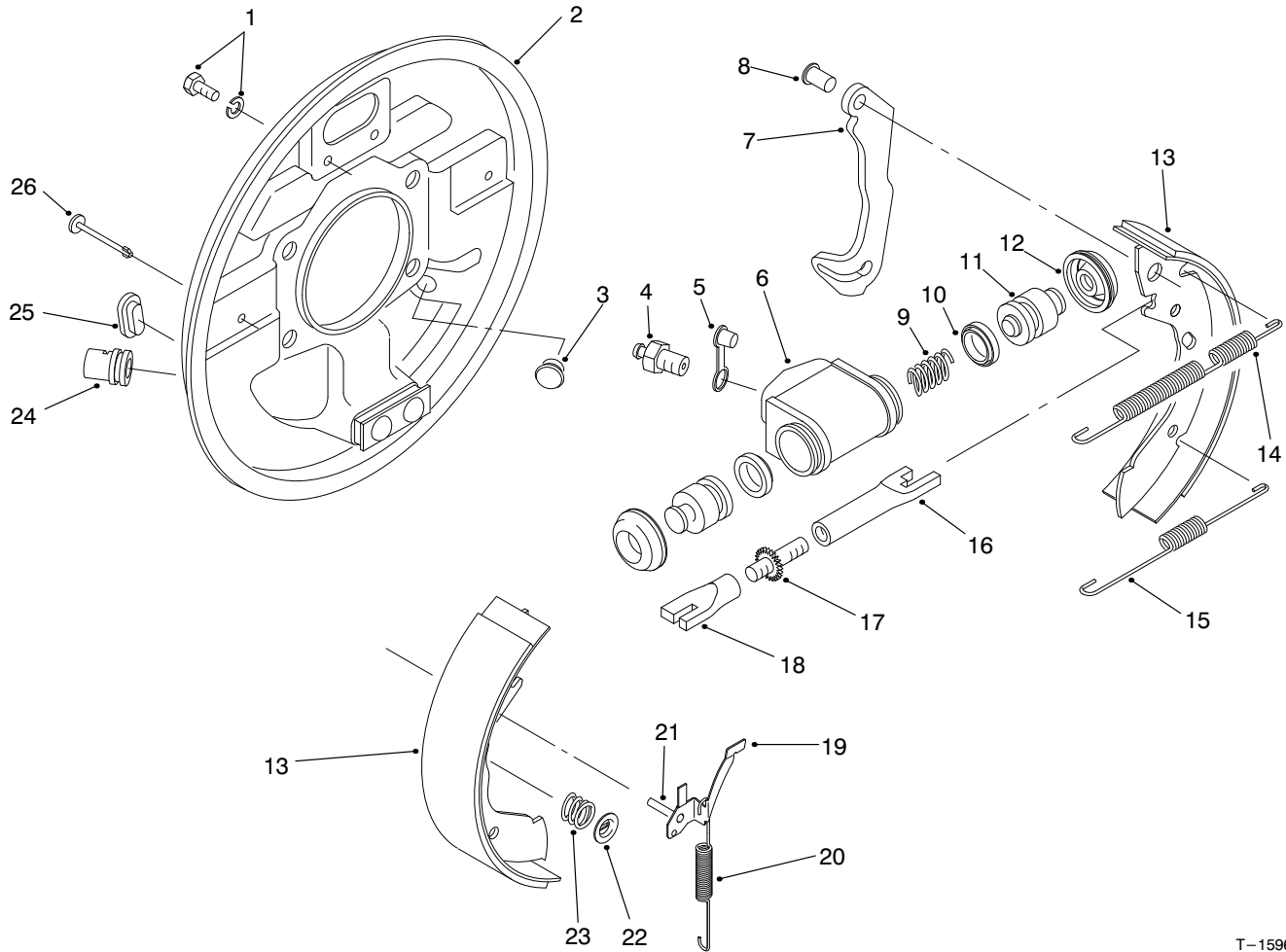

T-1596-1

FRONT BRAKE ASSEMBLY

Ref. No.	Part No.	Description	No. Used
1	92-4135	Set Bolt	2
2	92-4115	Backplate Assembly LH (Incl. Ref. #24)	1
*	92-4116	Backplate Assembly RH (Incl. Ref. #24)	1
3	92-4125	Plug	1
4	92-4113	Screw - Bleed	1
5	92-4114	Cap - Bleed Screw	1
6		Body	1
7		Lever - Operating LH/RH	1
8		Pin	1
9		Spring	1
10		Seal - 'L' Type	2
11		Piston	2
12		Cover - Dust	2
13	92-4120	Shoe & Lining Set (4 Shoes) (Incl. Ref. #7 & 8)	1
14	92-4126	Spring - Shoe, Upper LH	1
*	92-4127	Spring - Shoe, Upper RH	1
15	92-4128	Spring - Shoe, Lower	1
16		Pushrod - Female LH	1
*		Pushrod - Female RH	1
17		Bolt - Adjuster	1
18		Sleeve - Adjuster	1

Ref. No.	Part No.	Description	No. Used
19	92-4123	Pawl Assembly - LH (Incl. Ref. #21)	1
*	92-4124	Pawl Assembly - RH (Incl. Ref. #21)	1
20	92-4129	Spring - Adjuster, LH	1
*	92-4130	Spring - Adjuster, RH	1
21		Pin - Pawl	1
22	92-4131	Washer - Hold Down	2
23	92-4132	Spring - Hold Down	2
24		Guide - Pipe	1
25	92-4134	Plug - Inspection	1
26	92-4133	Pin - Hold Down	2
*	92-4121	Adjuster Assembly - LH (Incl. Ref. #16-18)	1
*	92-4122	Adjuster Assembly - RH (Incl. Ref. #16-18)	1
*	92-4117	Wheel Cylinder Assy. - LH (Incl. Ref. #4-6 & 9-12)	1
*	92-4118	Wheel Cylinder Assy. - RH (Incl. Ref. #4-6 & 9-12)	1
*	92-4119	Kit - Seal (Incl. Ref. #10 & 12)	1
*	87-3010	Front Brake Assembly - RH (Complete)	1
*	87-3020	Front Brake Assembly - LH (Complete)	1

*Not Illustrated

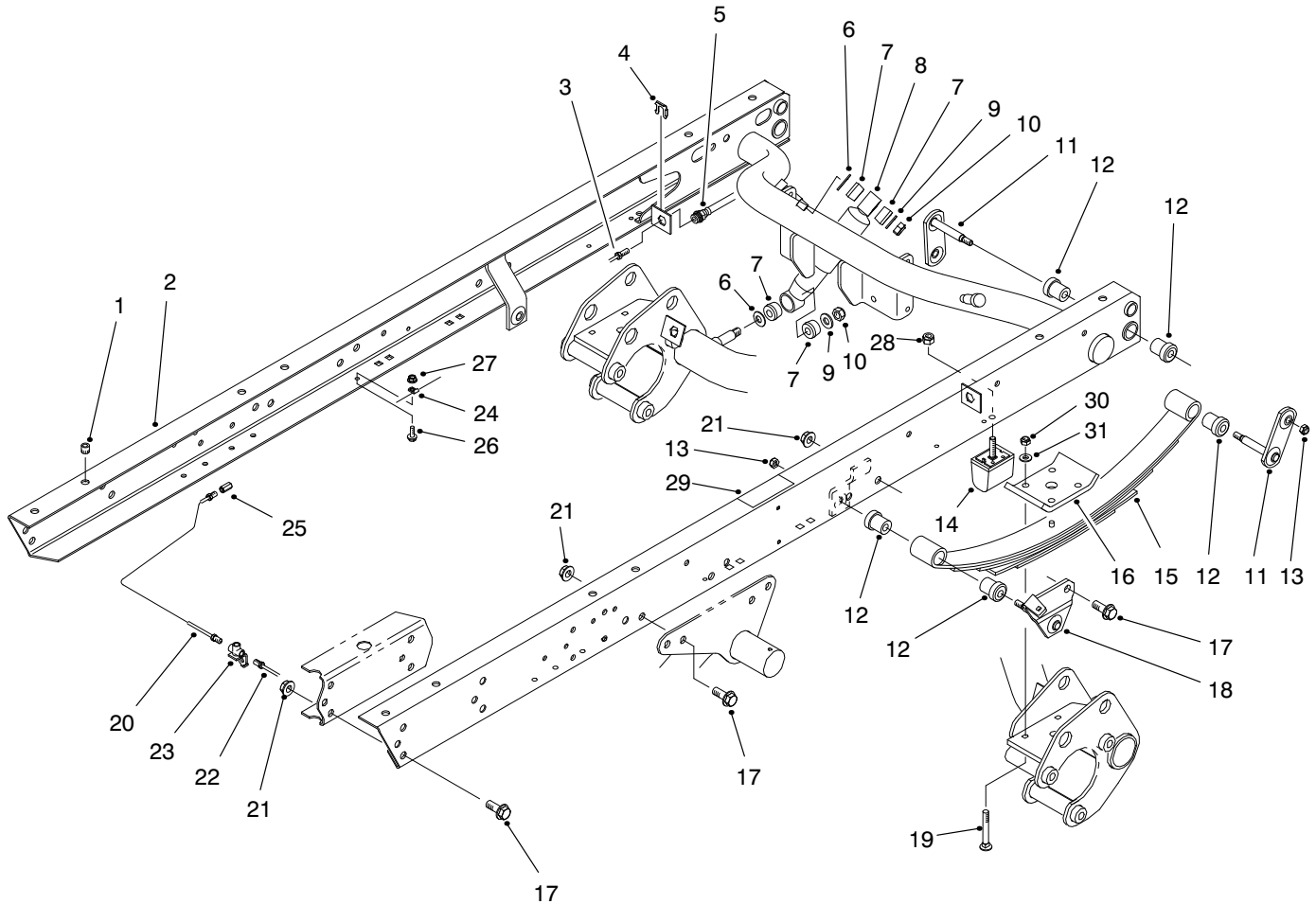

T-1778-1

REAR FRAME ASSEMBLY

Ref. No.	Part No.	Description	No. Used
1	32148-9	Insert - Threaded	8
2	87-8440	Rear Frame Assembly (Incl. Ref. #32)	1
3	94-3846	Tube - Brake RH	1
4	87-3580	Retainer	2
5	87-4100	Hose - Brake	2
6	3256-27	Washer - Flat	8
7	87-3920	Bushing - Rubber	8
8	87-3110	Shock Absorber	2
9	3256-6	Washer - Flat	4
10	3296-23	Nut - Lock	4
11	87-3980	Shackle - Spring	4
12	87-4760	Bushing	12
13	3296-39	Nut - Lock	6
14	87-3470	Bumper - Spring	2
15	87-1490	Spring - Leaf	2
16	87-7470	Plate - Clamp	2

Ref. No.	Part No.	Description	No. Used
17	3234-38	Screw - Hex. Flange Hd.	24
18	87-3960	Mount - Spring LH	1
*	87-3940	Mount - Spring RH	1
19	3232-17	Bolt - Carriage	8
20	94-3845	Tube - Hydraulic	1
21	32128-23	Nut - Flange Lock	24
22	94-3843	Tube - Brake LH	1
23	87-3560	Tee - Brake Tube	1
24	2412-149	Clamp - Tube	4
25	87-3570	Union - Brake	2
26	3234-4	Screw - Cap Hex. Hd.	3
27	32128-33	Nut - Flange Lock	4
28	48-9520	Nut - Lock	2
32	66-6840	Decal - Caution	1
33	3296-76	Nut - Lock	8
34	87-7480	Washer - Flat	8

*Not Illustrated

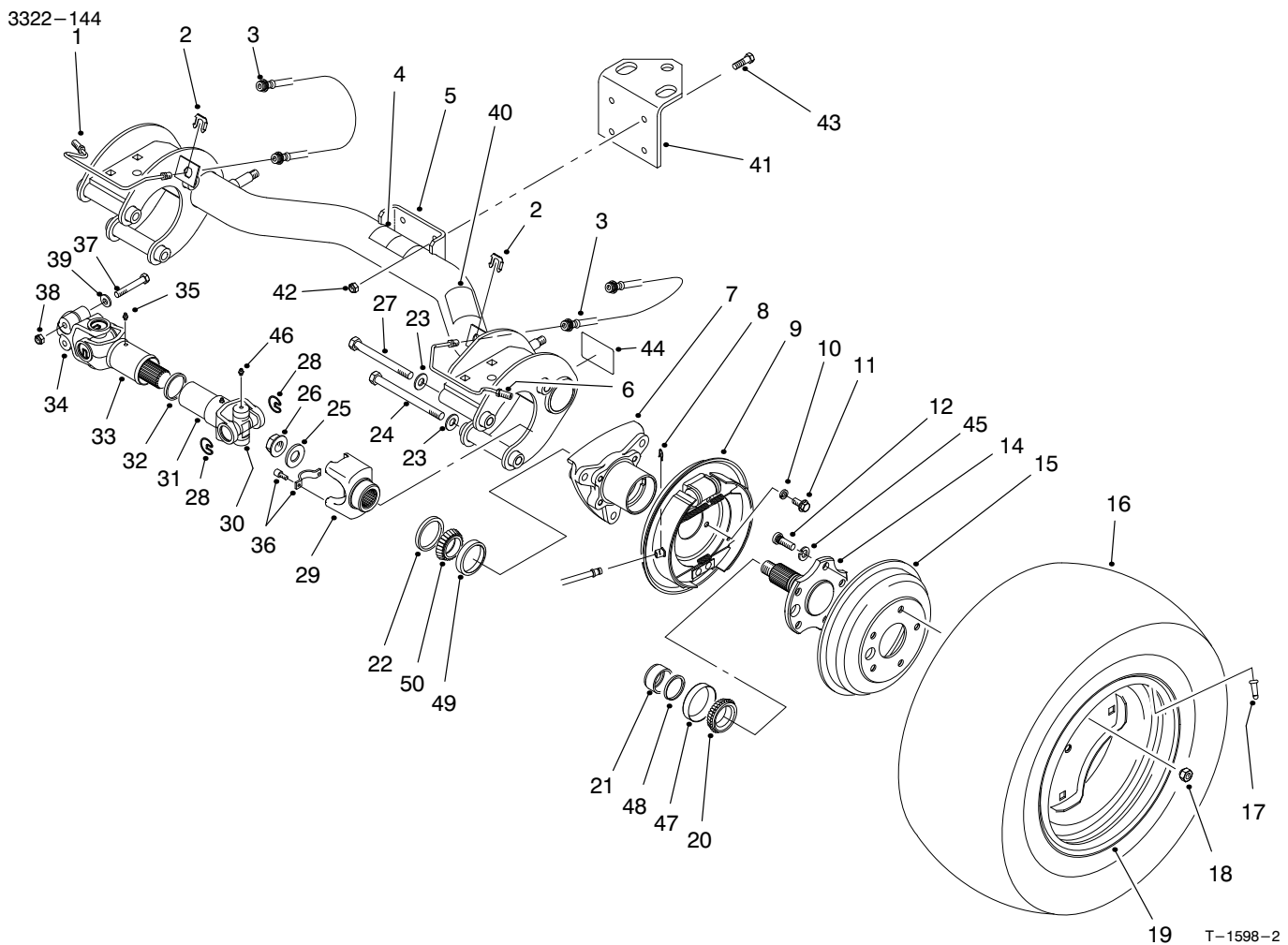

REAR AXLE ASSEMBLY

Ref. No.	Part No.	Description	No. Used
1	87-4090	Tube – Brake RH	1
2	87-3580	Retainer – Brake Hose	2
3	87-4100	Hose – Brake	2
4	87-6060	Decal – ATF	1
5	87-7110	Rear Axle Assembly (Incl. Ref. #4, 39 & 43)	1
6	87-4080	Tube – Brake LH	1
7	87-2240	Housing – Axle	2
8	87-3310	Clip – Brake Cable	2
9	93-7126	Brake Assembly LH	1
*	93-7125	Brake Assembly RH	1
10	3253-21	Washer – Lock	8
11	323-6	Screw – Cap Hex. Hd.	8
12	87-2080	Stud – Drive	10
14	93-7090	Stub – Axle	2
15	87-1840	Drum – Brake	2
16	87-3290	Tire – Rear 23"	2
*	Optional	Tire – Hard Surface & Traction Options (See Dealer/Distributor for Tire Selection Guide)	2
17	232-27	Valve – Stem	2
18	23-7270	Nut – Lug	10
19	87-3000	Rim – Rear 23"	2
*	87-6750	Rim – Rear 24" (Optional)	2
†20		Cone – Bearing	1

Ref. No.	Part No.	Description	No. Used
21	87-4060	Spacer – Bearing	2
22	87-3590	Seal – Bearing	2
23	87-7270	Washer – Flat	6
24	325-20	Screw – Cap Hex. Hd.	5
25	87-3060	Washer – Flat	2
26	32128-53	Nut – Flange Lock	2
27	325-19	Screw – Cap Hex. Hd.	1
28	92-4188	Ring – Snap	16
29	92-4190	Yoke – End	2
30	92-4187	Cross & Bearing Kit	4
31	92-4182	Yoke & Hub	2
32	92-4180	Seal	2
33	92-4179	Yoke, Shaft & Seal Tube	2
34	98-2940	Yoke – Double Clamp	2
35	302-5	Fitting – Grease	2
36	92-4189	Strap & Bolt Kit	2
37	98-2939	Screw – Cap Hex. Hd.	4
38	32128-36	Nut – Lock	4
39	80-6990	Washer	4
40	87-5990	Decal – PTO	1
41	92-5951	Angle – Hitch	1
42	3296-39	Nut – Lock	4
43	323-7	Screw – Cap Hex. Hd.	4
44	87-9080	Decal – Grease	2
45	3253-6	Washer – Lock	10
46	302-58	Fitting – Grease	16
47†		Cup – Bearing	1

*Not Illustrated

†Not Serviced Separately

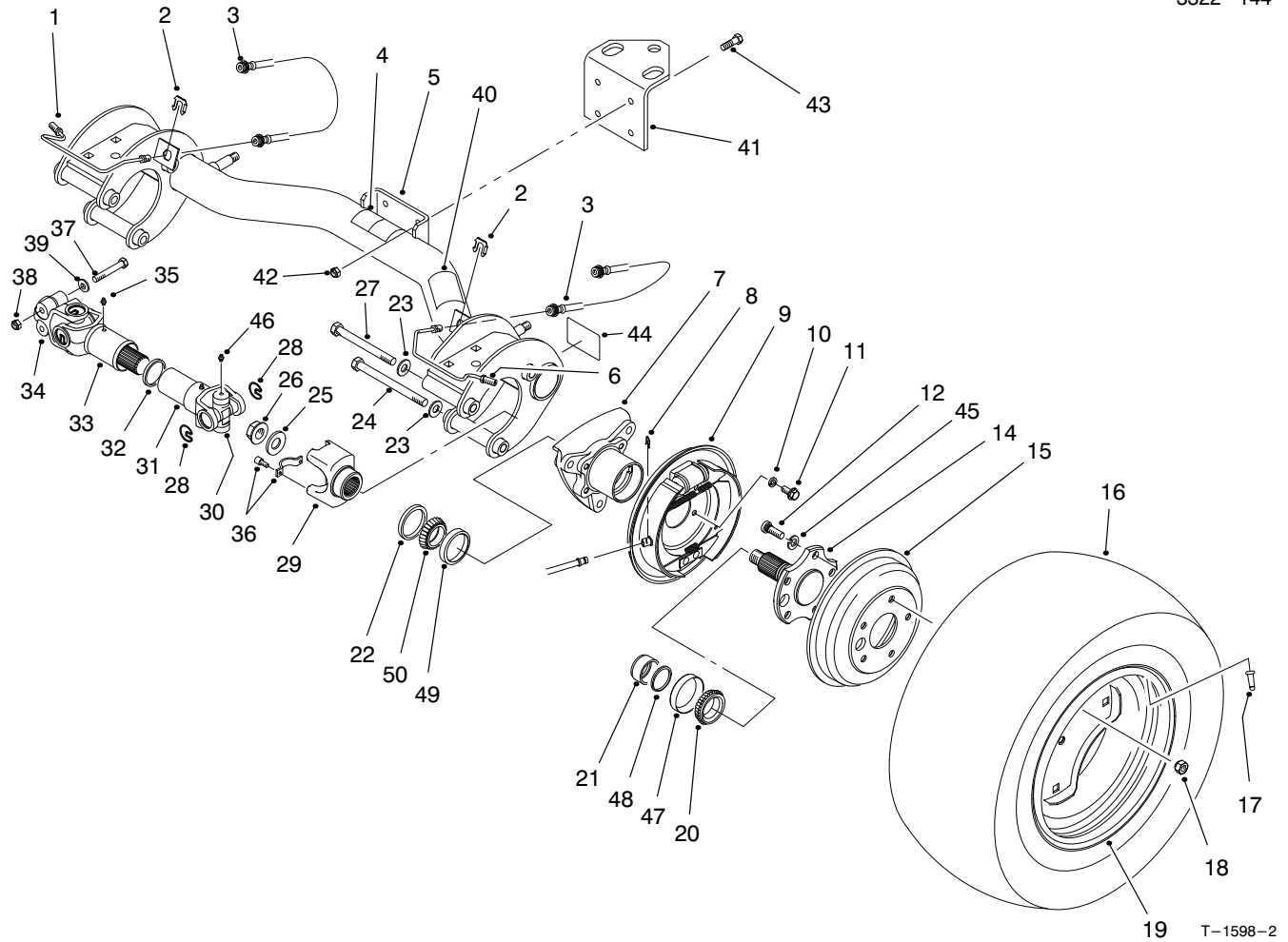

REAR AXLE ASSEMBLY (Continued)

Ref. No.	Part No.	Description	No. Used	Ref. No.	Part No.	Description	No. Used
†48		Spacer	1	*	87-1970	Bearing – Matched Set Use 1 set per wheel	
†49		Cup – Bearing	1			(Incl. Ref. #20 & 47-50)	2
†50		Cone – Bearing	1	*	98-2969	1/2 Yoke Kit	
*51	98-2918	Driveshaft Assembly (Incl. Ref. #28, 30-35 & 46)	2	*	98-2967	Driveshaft Assembly Kit (Incl. Ref. #29 & 36)	2
*	87-6370	Rear Tire & Wheel Assembly (23")	2	*	98-2968	Yoke Kit (Incl. Ref. #37 & 51)	2
*	87-5370	Rear Tire & Wheel Assembly (24")	2				2

*Not Illustrated
†Not Serviced Separately

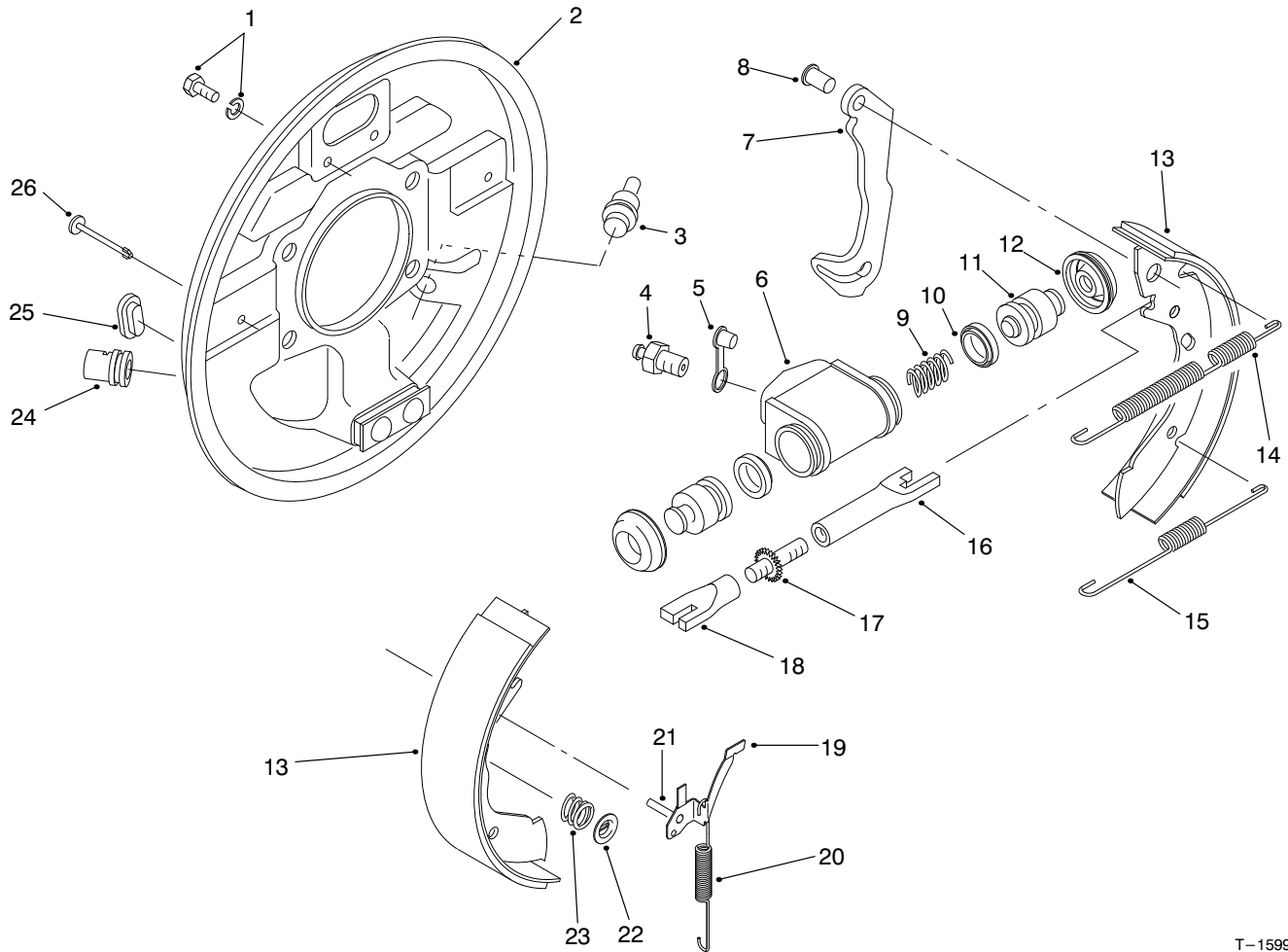

T-1599-1

REAR BRAKE ASSEMBLY

Ref. No.	Part No.	Description	No. Used	Ref. No.	Part No.	Description	No. Used
1	92-4135	Set Bolt	2	19	92-4123	Pawl Assembly - LH (Incl. Ref. #21)	1
2	92-4138	Backplate Assembly LH (Incl. Ref. #24)	1	*	92-4124	Pawl Assembly - RH (Incl. Ref. #21)	1
*	92-4139	Backplate Assembly RH (Incl. Ref. #24)	1	20	92-4150	Spring - Adjuster, LH	1
3	92-4146	Plug	1	*	92-4151	Spring - Adjuster, RH	1
4	92-4137	Screw - Bleed	1	21	92-4131	Pin - Pawl	1
5	92-4114	Cap - Bleed Screw	1	22	92-4131	Washer - Hold Down	2
6		Body	1	23	92-4152	Spring - Hold Down	2
7		Lever - Operating LH/RH	1	24		Guide - Pipe	1
8		Pin	1	25	92-4134	Plug - Inspection	1
9		Spring	1	26	92-4133	Pin - Hold Down	2
10		Seal - 'L' Type	2	*	92-4144	Adjuster Assembly - LH (Incl. Ref. #16-18)	1
11		Piston	2	*	92-4145	Adjuster Assembly - RH (Incl. Ref. #16-18)	1
12		Cover - Dust	2	*	92-4140	Wheel Cylinder Assy. - LH (Incl. Ref. #4-6 & 9-12)	1
13	92-4143	Shoe & Lining Set (4 Shoes) (Incl. Ref. #7 & 8)	1	*	92-4141	Wheel Cylinder Assy. - RH (Incl. Ref. #4-6 & 9-12)	1
14	92-4147	Spring - Shoe, Upper LH	1	*	92-4142	Seal Kit (Incl. Ref. #10 & 12)	1
*	92-4148	Spring - Shoe, Upper RH	1	*	93-7125	Rear Brake Assembly - RH (Complete)	1
15	92-4149	Spring - Shoe, Lower	1	*	93-7126	Rear Brake Assembly - LH (Complete)	1
16		Pushrod - Female LH	1				
*		Pushrod - Female RH	1				
17		Bolt - Adjuster	1				
18		Sleeve - Adjuster	1				

*Not Illustrated

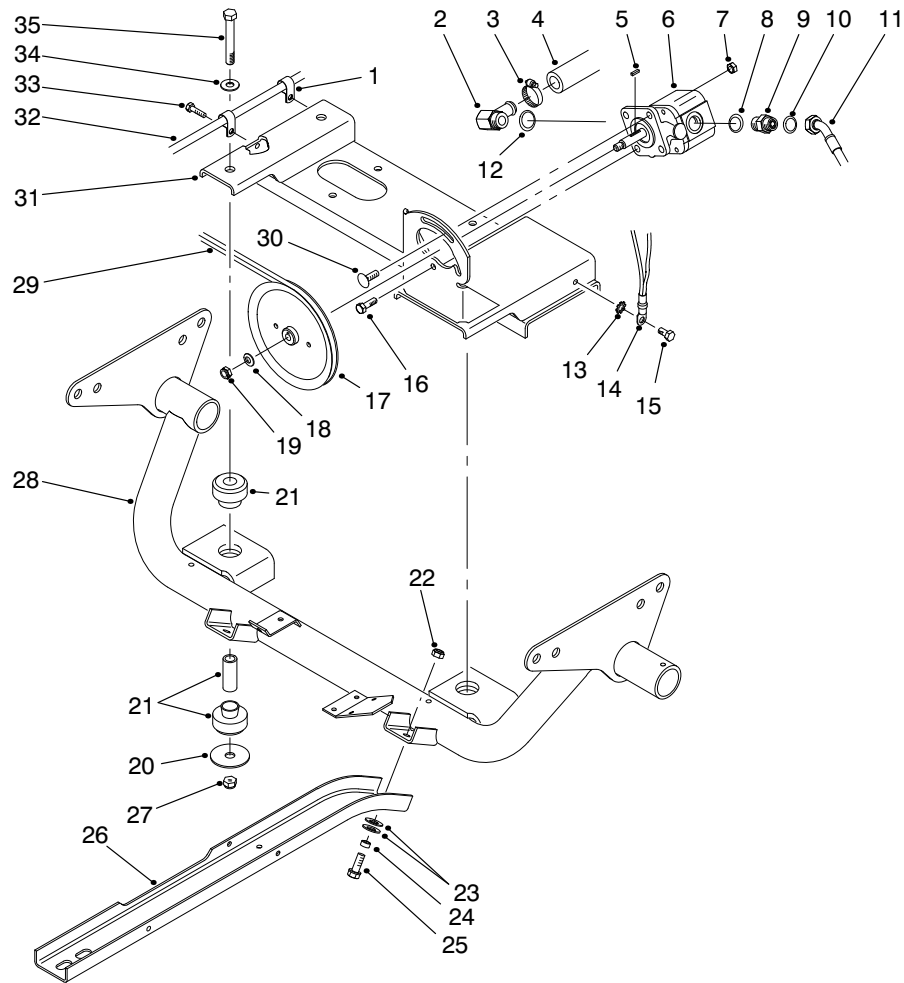

T-1735-1

ENGINE FRAME & HYDRAULIC PUMP DRIVE ASSEMBLY

Ref. No.	Part No.	Description	No. Used	Ref. No.	Part No.	Description	No. Used
1	2412-89	Clamp - R	2	17	87-7740	Pulley	1
2	87-8170	Fitting - Hydraulic 90° (Incl. Ref. #12)	1	18	3256-45	Washer - Flat	1
3	2412-34	Clamp - Hose	1	19	3296-5	Nut - Lock	1
4	87-8030	Hose - Hydraulic	1	20	87-5100	Washer - Snubbing	2
5	92-2179	Key - Square	1	21	87-4970	Engine Mount Assembly	2
6	87-5700	Hydraulic Pump Assembly (Incl. Ref. #5)	1	22	3296-39	Nut - Lock	6
7	3296-29	Nut - Lock	2	23	3290-413	Washer - Belleville	12
8	237-79	Seal - O-Ring	1	24	76-9100	Spacer	6
9	340-3	Fitting - Hydraulic Straight (Incl. Ref. #8 & 10)	1	25	3234-11	Screw - Cap Hex. Hd.	6
10	237-22	Seal - O-Ring	1	26	87-4730	Guard - Belly	2
11	87-8020	Hose - Hydraulic	1	27	3296-48	Nut - Lock	2
12	237-80	Seal - O-Ring	1	28	93-7095	Support - Engine	1
13	3255-8	Washer - Lock ETLW	1	29	87-8370	Belt - V	1
14	87-3080	Cable - Battery Negative	1	30	3230-22	Bolt - Carriage	1
15	32144-14	Screw - Self Tapping	1	31	87-6400	Frame - Engine	1
16	322-5	Screw - Cap Hex. Hd.	1	32	87-8240	Cable - Parking Brake	2
				33	32144-10	Screw - Self Tapping	2
				34	3256-25	Washer - Flat	2
				35	324-12	Screw - Cap Hex. Hd.	2

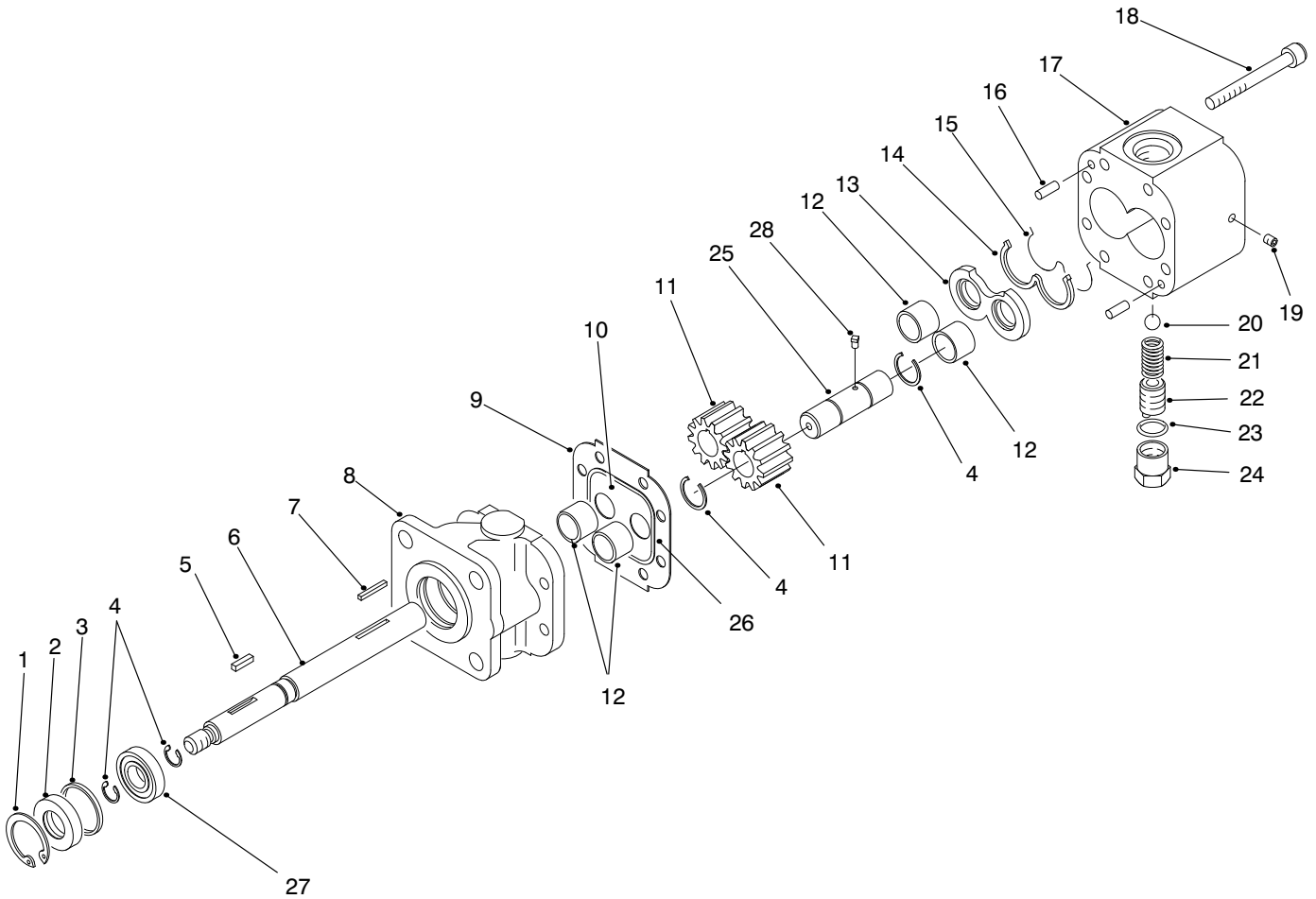

T-1601-1

HYDRAULIC PUMP ASSEMBLY NO. 87-5700

Ref. No.	Part No.	Description	No. Used
1	32151-41	Ring - Retaining	1
2	92-2195	Seal - Oil	1
3	92-2186	Spacer	1
4	92-2178	Ring - Crescent	4
5	92-2179	Key - Square	1
6	92-2189	Shaft - Drive	1
7	92-2177	Pin - Shear	1
†8		Stator	1
9	92-2182	Plate - Seal	1
10	92-2183	Plate - Wear	1
11	92-2175	Gear	2
12	92-2192	Bearing	4
13	92-2181	Plate - Pressure	1
14	92-2197	Seal - Back Up	1

Ref. No.	Part No.	Description	No. Used
15	92-2196	Seal - Pressure Plate	1
16	92-2176	Pin - Dowel	2
17	92-2187	Housing - Gear, End	1
18	92-2173	Screw - Cap Socket Head	8
19	92-2185	Plug	1
20	92-2193	Ball	1
21	92-2194	Spring	1
22	92-2174	Screw - Adjusting	1
23	92-2180	Gasket - Copper	1
24	92-2184	Cap - Relief Valve	1
25	92-2190	Shaft - Idler	1
26	92-2198	Seal	1
27	92-2191	Bearing	1
28	92-2199	Key - Ball	1

† Not Serviced Separately.

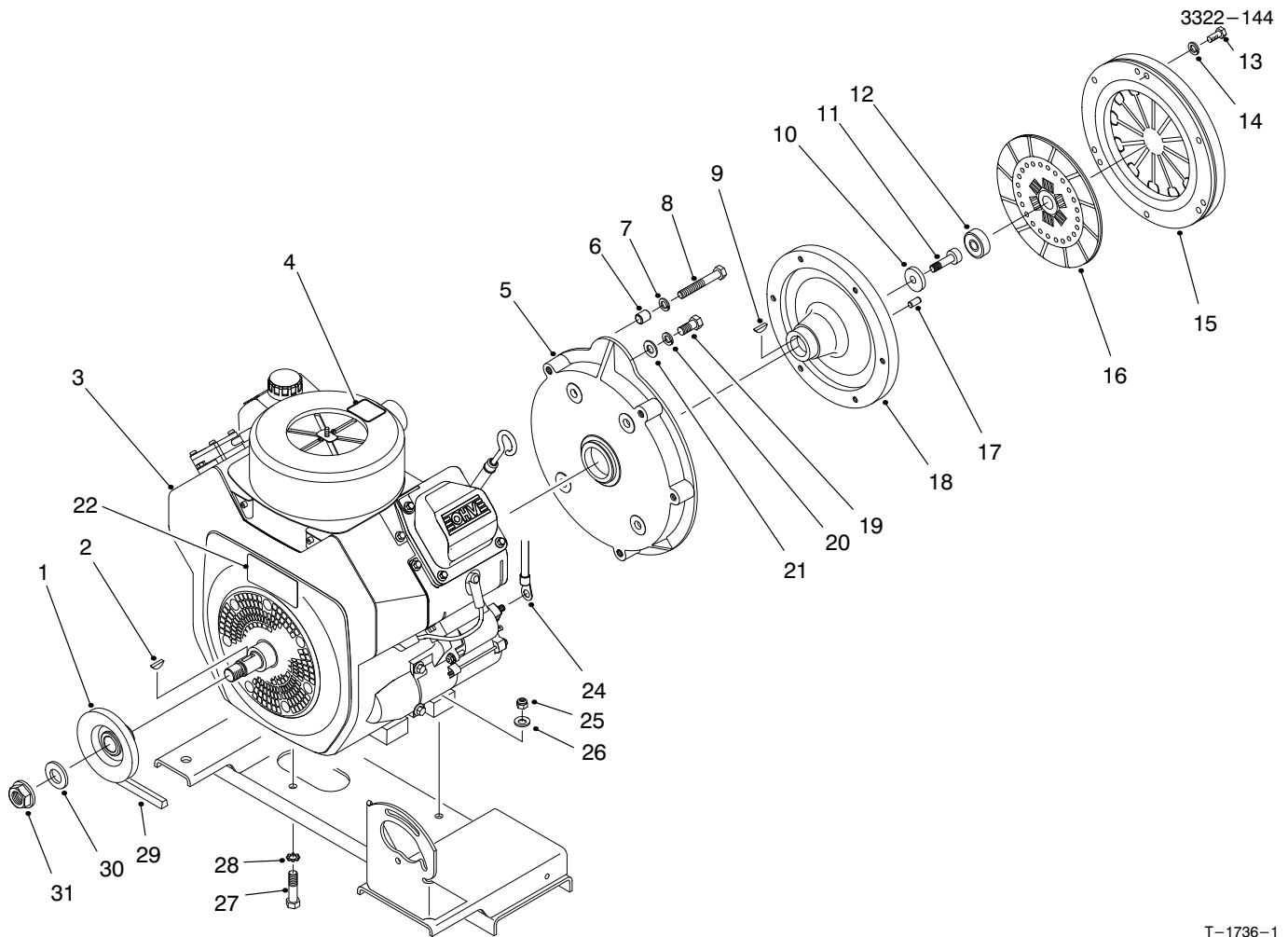

T-1736-1

ENGINE INSTALLATION ASSEMBLY

Ref. No.	Part No.	Description	No. Used
1	87-7710	Pulley	1
2	3257-7	Key - Woodruff	1
3	87-7900	Engine Assembly	1
4	87-8770	Decal - Air Cleaner	1
5	87-6390	Adapter - Clutch	1
6	92-2152	Bushing - Dowel	2
7	3253-22	Washer - Lock	4
8	56-2150	Screw - Cap Hex. Hd.	4
9	3257-5	Key - Woodruff	1
10	87-6080	Washer	1
11	3274-1	Screw - Hex. Socket Hd.	1
12	87-6460	Bearing - Pilot	1
13	33114-016	Screw - Cap Hex. Hd.	6
14	3253-4	Washer - Lock	6
15	98-2558	Cover - Clutch	1

Ref. No.	Part No.	Description	No. Used
16	98-2559	Disk - Clutch	1
17	42-7160	Pin - Dowel	3
18	87-6480	Flywheel	1
19	324-4	Screw - Cap Hex. Hd.	4
20	3253-6	Washer - Lock	4
21	3256-25	Washer - Flat	4
22	80-8040	Decal - Warning	1
24	87-8000	Cable - Battery Positive	1
25	3296-39	Nut - Lock	4
26	3256-24	Washer - Flat	4
27	323-9	Screw - Cap Hex. Hd.	4
28	3255-9	Washer - Lock	1
29	87-8370	Belt - V	1
30	3256-28	Washer - Flat	1
31	3296-15	Nut - Lock	1

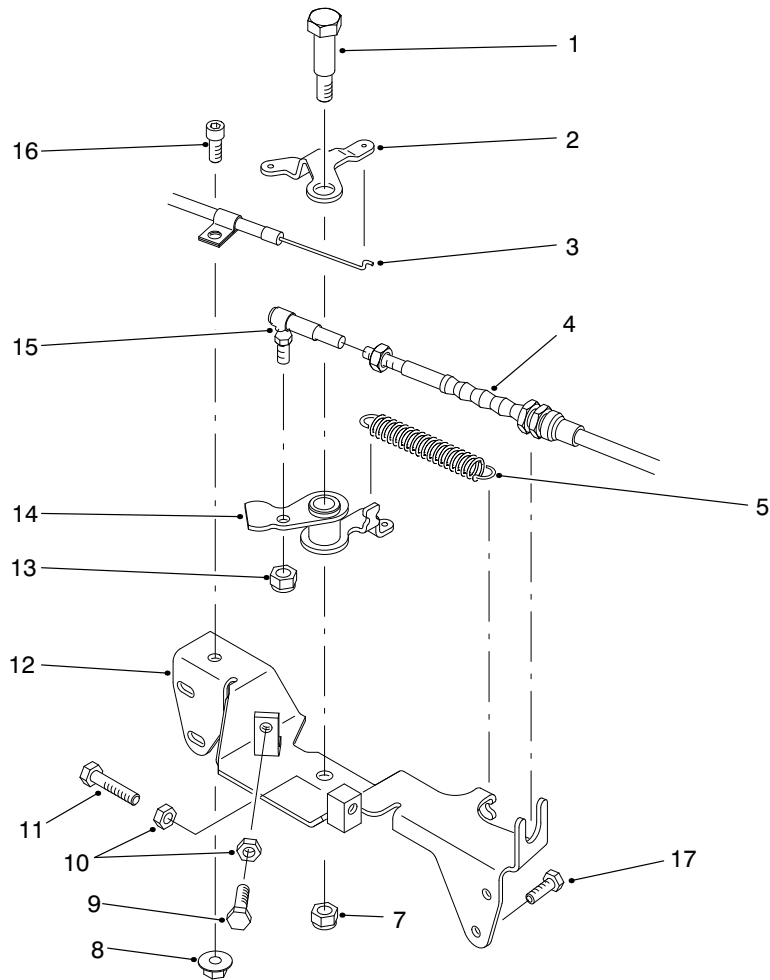

T-1802-2

THROTTLE LINKAGE ASSEMBLY

Ref. No.	Part No.	Description	No. Used	Ref. No.	Part No.	Description	No. Used
1	7-0030	Bolt - Shoulder	1	10	3220-1	Nut - Jam	2
2	87-7790	Lever - Choke	1	11	329-7	Screw - Cap Hex. Hd.	1
3	87-8060	Cable - Choke	1	12	87-7780	Bracket - Throttle	1
4	94-3834	Cable - Accelerator	1	13	3296-3	Nut - Lock	1
5	67-1450	Spring - Extension	1	14	87-7800	Lever - Throttle	1
7	3296-29	Nut - Lock	1	15	18-1720	Joint - Ball	1
8	32128-33	Nut - Flange Lock	1	16	3274-15	Screw - Hex. Socket Hd.	1
9	329-6	Screw - Cap Hex. Hd.	1	17	32144-4	Screw - HH	2

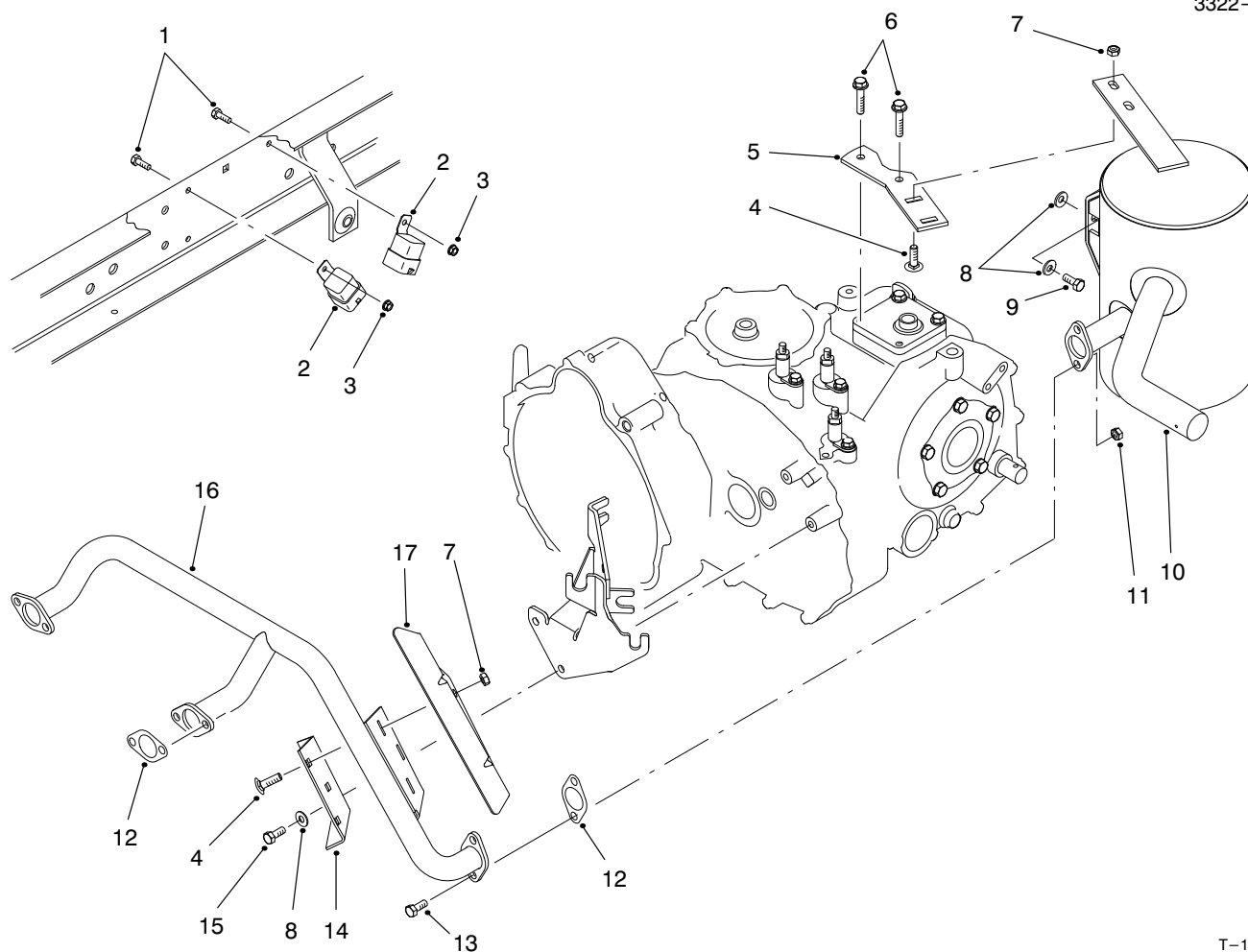

T-1807-1

MUFFLER & RELAY ASSEMBLY

Ref. No.	Part No.	Description	No. Used	Ref. No.	Part No.	Description	No. Used
1	321-4	Screw - Cap Hex. Hd.	2	10	87-7840	Muffler - Exhaust	1
2	70-1480	Relay	2	11	32128-25	Nut - Lock	2
3	32128-33	Nut - Flange Lock	2	12	87-8650	Gasket - Muffler	3
4	3230-2	Bolt - Carriage	5	13	322-4	Screw - Cap Hex. Hd.	2
5	87-8680	Plate - Muffler Mount	1	14	87-7980	Bracket - Muffler	1
6	33114-030	Screw - Cap Hex. Hd.	2	15	33114-025	Screw - Cap Hex. Hd.	2
7	32128-20	Nut - Flange Lock	5	16	87-7850	Manifold - Exhaust	1
8	87-8640	Washer - Flat	4	17	87-7860	Shield - Heat	1
9	33114-020	Screw - Cap Hex. Hd.	1				

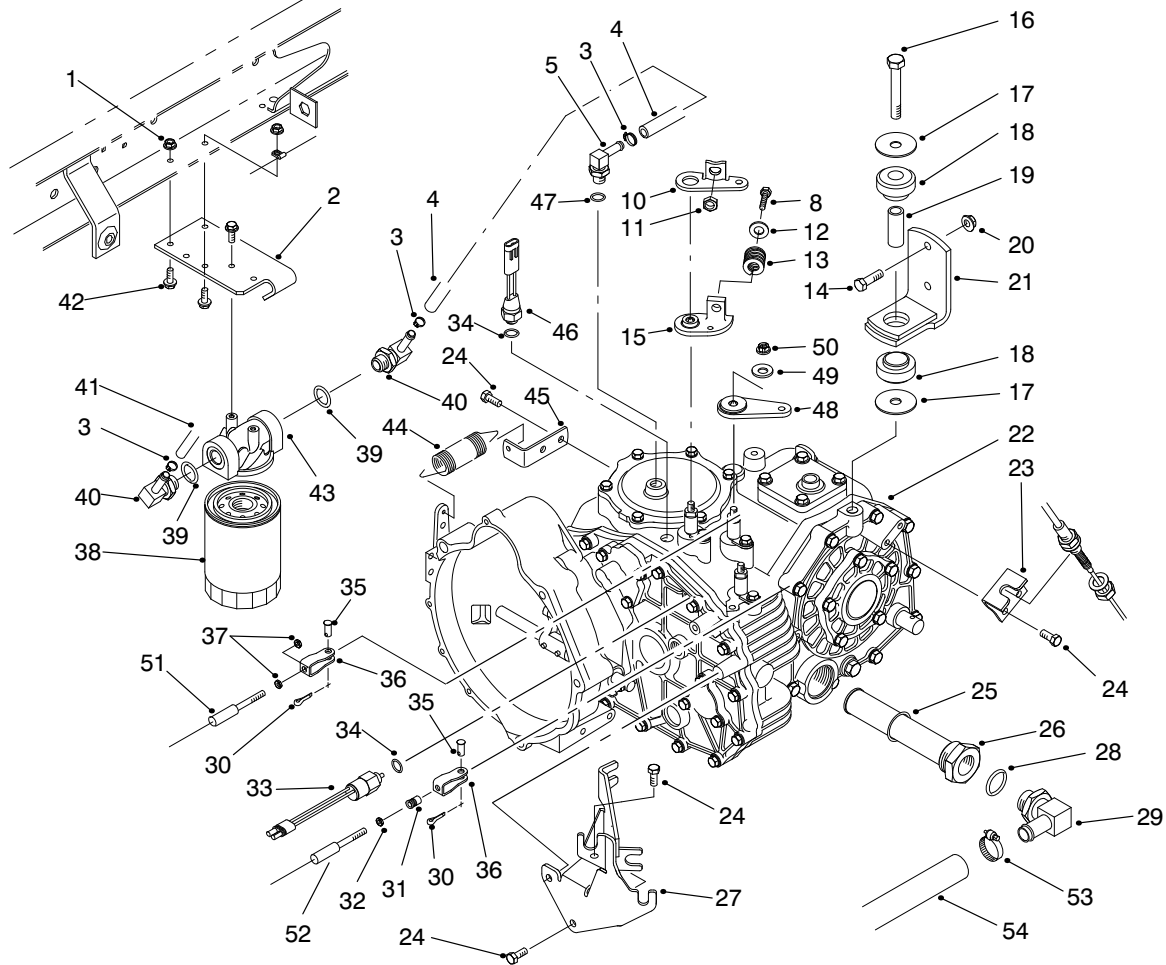

T-1607-1

TRANSAXLE INSTALLATION ASSEMBLY

Ref. No.	Part No.	Description	No. Used	Ref. No.	Part No.	Description	No. Used
1	32128-33	Nut - Flange Lock	1	27	87-4820	Bracket - Cable	1
2	87-7040	Bracket - Oil Filter	1	28	237-81	Seal - O-Ring	1
3	2412-36	Clamp - Hose	3	29	353-987	Fitting - Hydraulic 90° (Incl. Ref. #28)	1
4	87-5730	Hose - Hydraulic	1	30	3272-6	Pin - Cotter	3
5	354-135	Fitting - Hydraulic 90° (Incl. Ref. #47)	1	31	32148-15	Nut - Clinch	1
8	323-10	Screw - Cap Hex. Hd.	1	32	3219-14	Nut - Hex.	1
10	87-8250	Plate - Shift Arm	1	33	87-6710	Switch - Supervisor	1
11	32128-21	Nut - Lock	1	34	237-30	O-Ring	2
12	3256-4	Washer - Flat	1	35	283-62	Pin - Clevis	3
13	87-6910	Spring - Compression	1	36	87-2310	Clevis - Cable	3
14	323-7	Screw - Cap Hex. Hd.	4	37	3220-1	Nut - Jam	4
15	87-7970	Arm - Shift	1	38	54-0110	Element - Oil Filter	1
16	3215-1	Screw - Cap Hex. Hd.	2	39	237-79	Seal - O-Ring	2
17	87-5100	Washer	4	40	354-134	Fitting - Hydraulic 90° (Incl. Ref. #39)	2
18	87-4970	Transaxle Mount Assembly (Incl. Ref. #19)	4	41	87-4920	Hose - Hydraulic	1
19		Spacer - Mount	2	42	3234-4	Screw - Hex. Flange Hd.	4
20	3296-39	Nut - Flange Lock	4	43	87-8780	Head - Oil Filter	1
21	87-5800	Bracket - Mount	2	44	68-9950	Spring - Extension	1
22	87-9250	Transaxle Assembly	1	45	87-7170	Bracket - Clutch Spring	1
23	87-4470	Bracket	1	46	72-4310	Switch - Ball N.C.	1
24	33114-020	Screw - Cap Hex. Hd.	5	47	237-42	Seal - O-Ring	1
25	237-123	Seal - O-Ring	1	48	87-7960	Clamp - Shift Arm	2
26	87-3990	Oil Strainer Assembly (Incl. Ref. #25)	1	49	80-6990	Washer - Flat	3
				50	48-9520	Nut - Lock	3

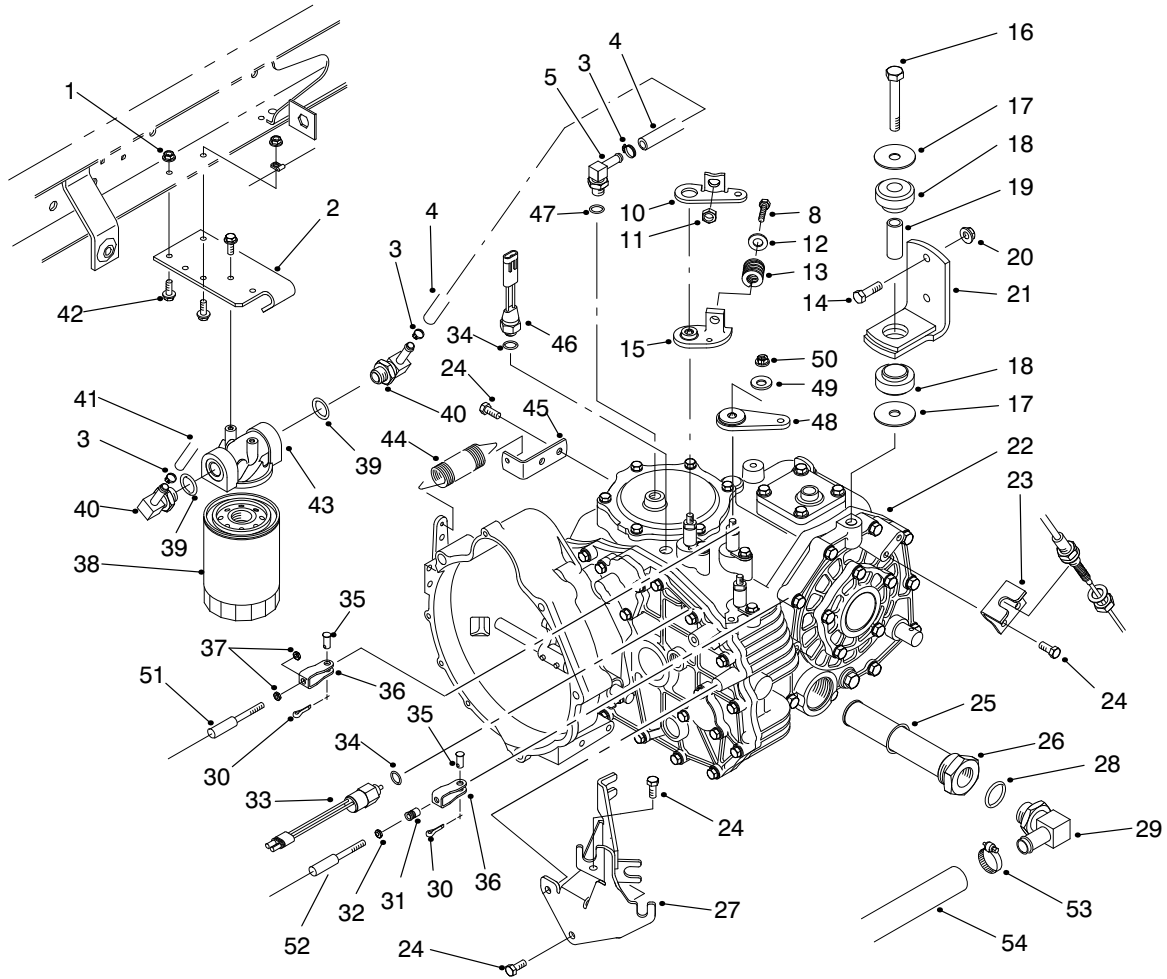

T-1607-1

TRANSAXLE INSTALLATION ASSEMBLY (Continued)

Ref. No.	Part No.	Description	No. Used	Ref. No.	Part No.	Description	No. Used
51	87-4260	Shift Cable Assembly (Incl. Ref. #37)	2	53	2412-34	Clamp - Hose	1
52	87-4420	Hi-Lo Cable Assembly (Incl. Ref. #32)	1	54	87-8030	Hose - Hydraulic	1

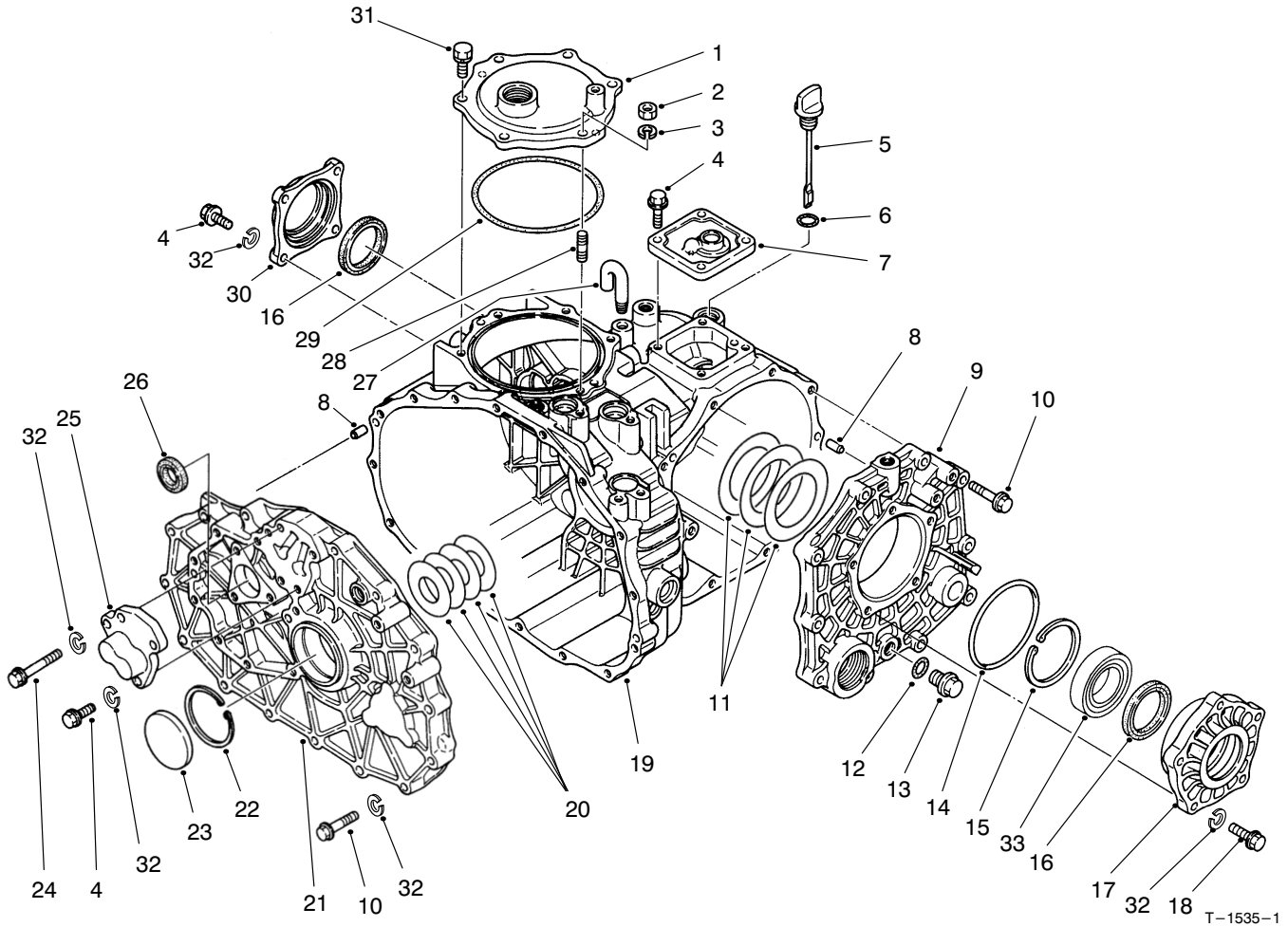

TRANSAXLE CASE ASSEMBLY

T-1535-1

Ref. No.	Part No.	Description	No. Used
1	92-0656	Cover - P.T.O.	1
2	48-7930	Nut - Hex.	1
3	92-0762	Washer - Lock	1
4	60-6750	Screw - Cap Hex. Hd.	11
5	92-0662	Cap - Oil	1
6	92-0788	O-Ring	1
7	92-0652	Cover - Upper	1
8	92-0765	Pin - Alignment	4
9	92-0653	Cover - Side	1
10	42-9530	Screw - Cap Hex. Hd.	25
11	92-0809	Shim Set	1
12		O-Ring	1
13	92-0773	Drain Plug Assembly (Incl. Ref. #12)	1
14	92-0789	O-Ring	1
15	92-0760	Ring - Retaining	1
16	92-0793	Seal - Oil	2

Ref. No.	Part No.	Description	No. Used
17	92-0654	Carrier - Differential	1
18	48-7730	Screw - Cap Hex. Hd.	5
19	92-0651	Case - Transaxle	1
20	92-0808	Shim Set	1
21	92-0657	Plate - Center	1
22	92-0759	Ring - Retaining	1
23	92-0807	Cap - Sealing	1
24	48-7560	Screw - Cap Hex. Hd.	1
25	92-0706	Cap - Fork Shaft	1
26	92-0791	Seal - Oil	1
27	92-0743	Breather - Air	1
28	92-0804	Stud	1
29	92-0790	O-Ring	1
30	92-0655	Cover - Seal	1
31	92-0796	Screw - Cap Hex. Hd.	5
32	42-9850	Washer - Lock	42
33	92-0775	Bearing - Ball	2

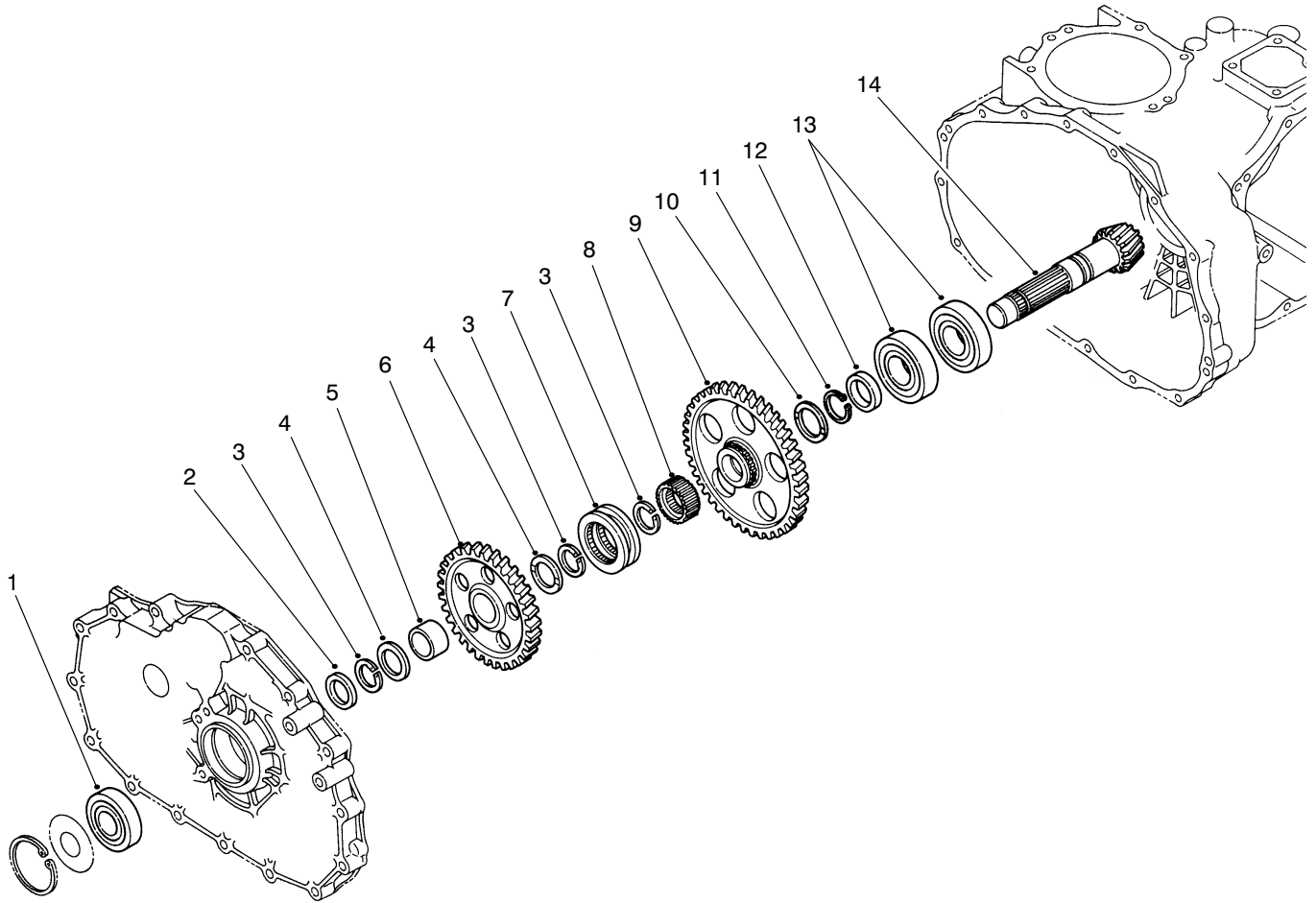

T-1536-1

COUNTERSHAFT ASSEMBLY

Ref. No.	Part No.	Description	No. Used
1	92-0712	Bearing - Ball	1
2	92-0716	Collar	1
3	92-0764	Ring - Retaining	3
4	92-0711	Washer - Thrust	2
5	92-0783	Sleeve - Inner	1
6	92-0715	Gear - 49T	1
7	92-0718	Shifter - Hi-Lo	1
8	92-0719	Collar - Spline	1

Ref. No.	Part No.	Description	No. Used
9	92-0717	Gear - 71T	1
10	92-0741	Washer - Thrust	1
11	92-0755	Ring - Retaining	1
12	92-0713	Collar	1
13	92-0714	Bearing - Ball	2
14	92-0710	Counter Shaft Assembly (Incl. Ring Gear)	1

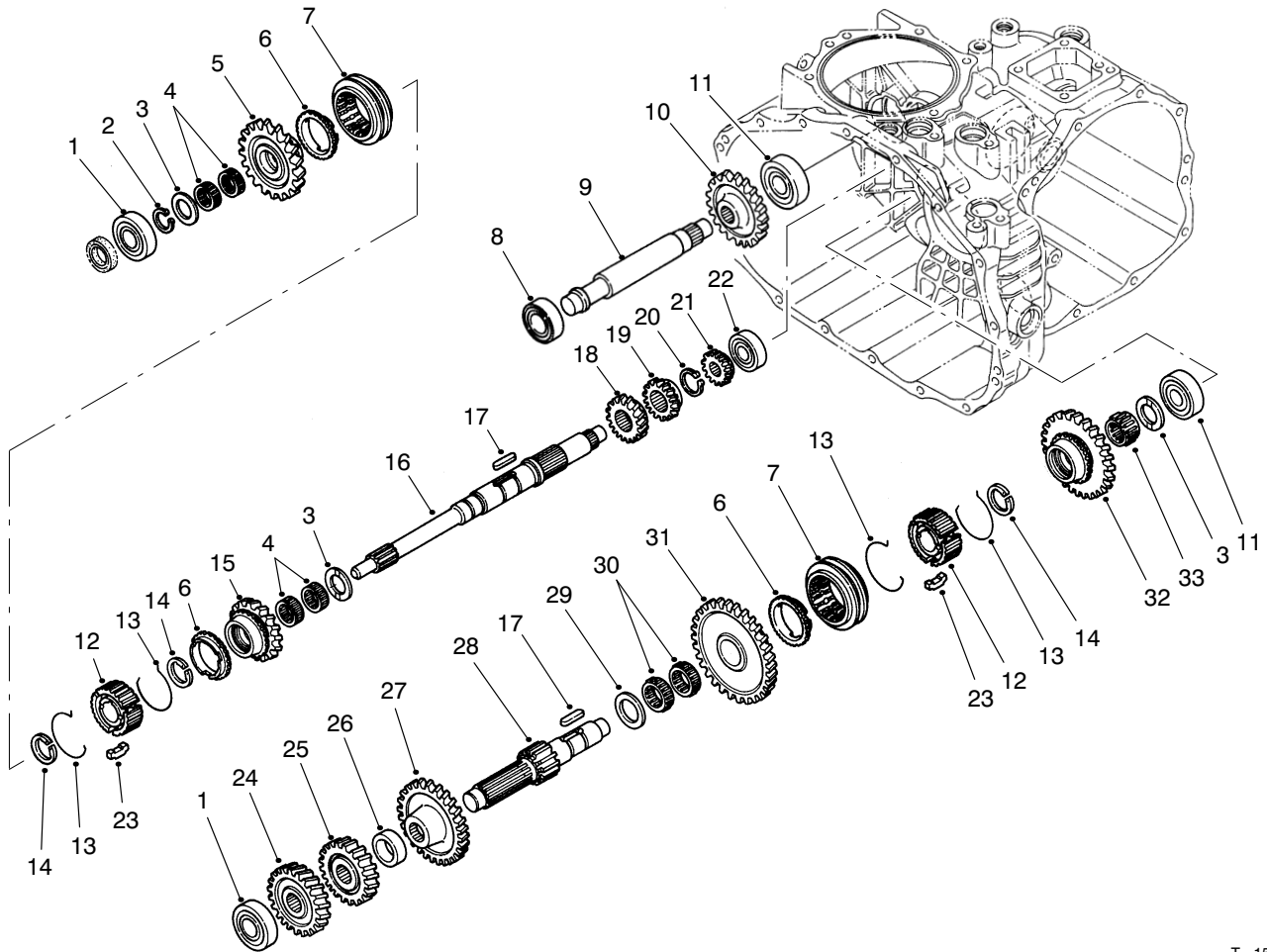

T-1533-1

TRANSAXLE GEAR SHAFTS ASSEMBLY

Ref. No.	Part No.	Description	No. Used
1	251-8	Bearing - Ball	2
2	92-0753	Ring - Retaining	1
3	92-0740	Washer - Thrust	3
4	92-0781	Bearing - Needle	4
5	92-0820	Gear - 27T	1
6	92-0667	Ring - Synchro	3
7	92-0668	Shifter - Synchro	2
8	251-346	Bearing - Ball	1
9	92-0824	Shaft - Reverse Idler	1
10	92-0684	Gear - 33T	1
11	92-0778	Bearing - Ball	2
12	92-0664	Hub - Synchro	2
13	92-0666	Spring - Synchro	4
14	92-0763	Ring - Retaining	3
15	92-0821	Gear - 24T	1
16	92-0663	Shaft - Main	1
17	92-0772	Key	2

Ref. No.	Part No.	Description	No. Used
18	92-0687	Gear - 16T	1
19	92-0672	Gear - 18T	1
20	92-0754	Ring - Retaining	1
21	92-0673	Gear - 14T	1
22	92-0650	Bearing - Ball	1
23	92-0665	Key - Synchro	6
24	92-0822	Gear - 28T	1
25	92-0679	Gear - 23T	1
26	92-0680	Collar	1
27	92-0823	Gear - 43T	1
28	92-0674	Shaft - Reduction	1
29	92-0682	Washer - Thrust	1
30	92-0681	Bearing - Needle	2
31	92-0677	Gear - 49T	1
32	92-0819	Gear - 40T	1
33	92-0782	Bearing - Needle	1

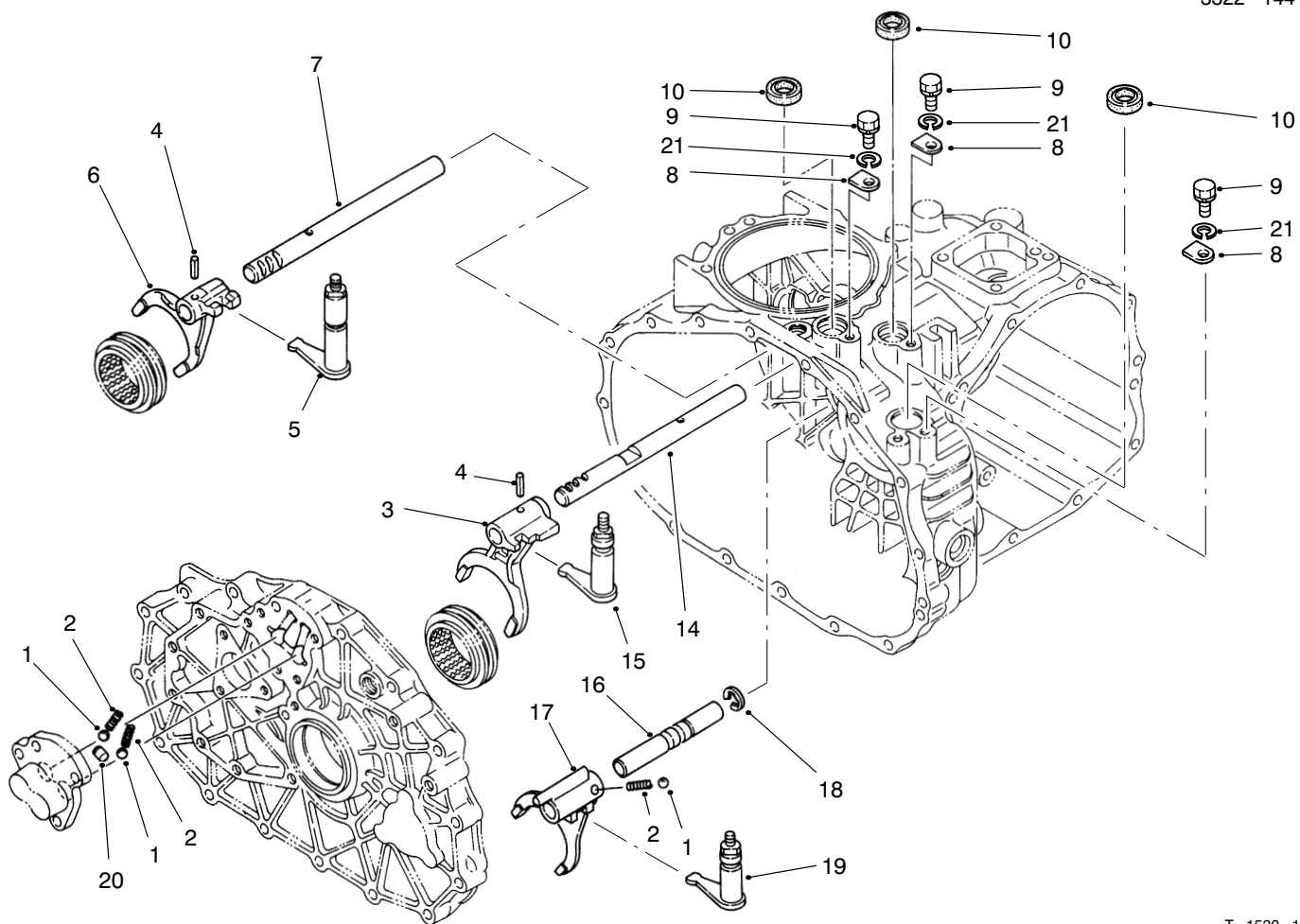

T-1530-1

SHIFT FORK ASSEMBLY

Ref. No.	Part No.	Description	No. Used
1	92-0785	Ball	3
2	92-0731	Spring - Compression	3
3	92-0700	Fork - Shift R-1	1
4	92-0769	Pin - Spring	2
5	92-0817	Arm - Shift Fork 2-3	1
6	92-0701	Fork - Shift 2-3	1
7	92-0699	Shaft - Fork 2-3	1
8	92-0732	Plate - Keeper	3
9	48-7700	Screw - Cap Hex. Hd.	3

Ref. No.	Part No.	Description	No. Used
10	92-0729	Seal - Oil	3
14	92-0698	Shaft - Fork R-1	1
15	92-0816	Arm - Shift Fork R-1	1
16	92-0708	Shaft - Fork Hi-Lo	1
17	92-0709	Fork - Shift Hi-Lo	1
18	92-0761	Ring - Retaining	1
19	92-0818	Arm - Shift Fork Hi-Lo	1
20	92-0705	Lock - Spindle	1
21	42-9850	Washer - Lock	3

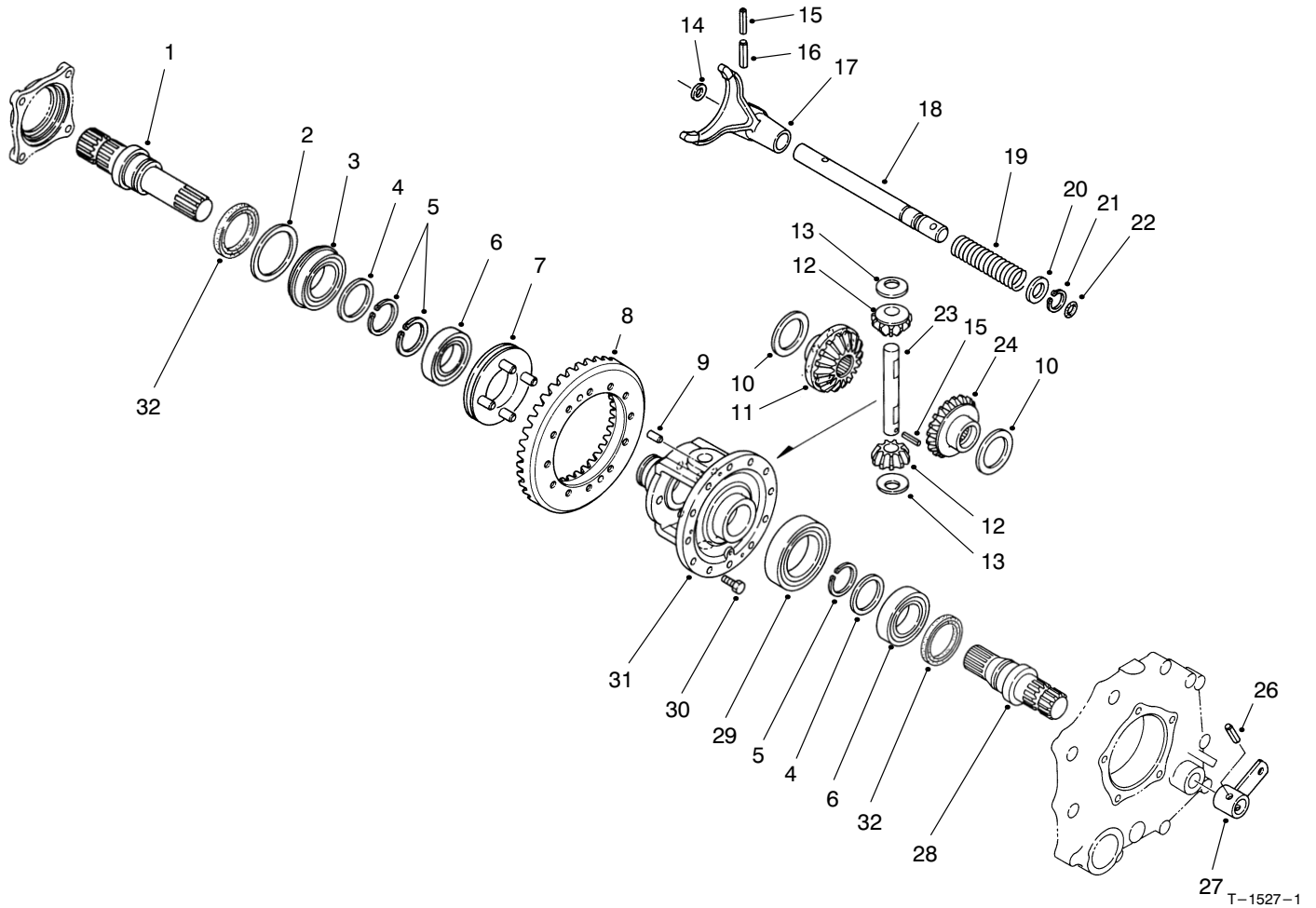

DIFFERENTIAL GEAR ASSEMBLY

Ref. No.	Part No.	Description	No. Used
1	92-0726	Shaft - Axle R.H.	1
2	92-0728	Washer	1
3	92-0780	Bearing - Ball	1
4	92-0727	Washer	2
5	92-0756	Ring - Retaining	3
6	92-0775	Bearing - Ball	2
7	92-0730	Slider - Differential Lock	1
8	92-0710	Ring Gear Assembly (Incl. Counter Shaft)	1
9	92-0765	Pin - Alignment	2
10	92-0747	Washer - Thrust	2
11	92-0746	Gear - Side R.H.	1
12	92-0748	Gear - Pinion	2
13	92-0750	Washer	2
14	92-0744	Washer	1
15	92-0768	Pin - Spring	2

Ref. No.	Part No.	Description	No. Used
16	92-0771	Pin - Spring	1
17	92-0721	Fork - Differential Lock	1
18	92-0722	Shaft - Lock Fork	1
19	92-0723	Spring - Compression	1
20	92-0733	Washer	1
21	92-0753	Ring - Retaining	1
22	92-0787	O-Ring	1
23	92-0749	Shaft - Pinion	1
24	92-0745	Gear - Side L.H.	1
26	92-0770	Pin - Spring	1
27	92-0724	Arm - Differential Lock	1
28	92-0725	Shaft - Axle L.H.	1
29	92-0776	Bearing - Ball	1
30	92-0803	Screw - Hex. Flange Hd.	12
31	92-0720	Case - Differential	1
32	92-0793	Seal - Oil	2

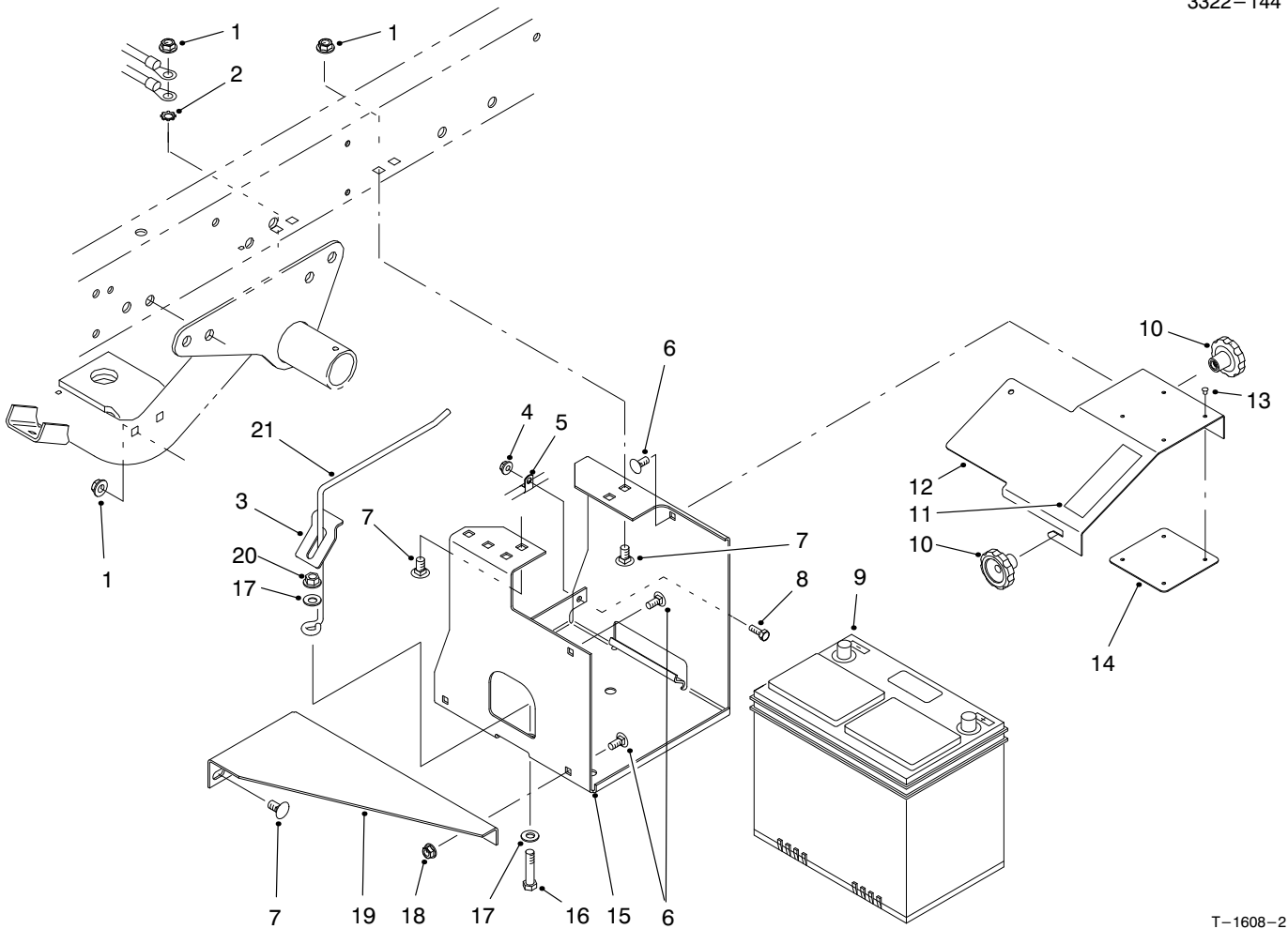

T-1608-2

BATTERY MOUNT ASSEMBLY

Ref. No.	Part No.	Description	No. Used
1	3290-357	Nut - Flange Lock	6
2	3255-9	Washer - Lock ETLW	1
3	87-7610	Tab - Battery Support	1
4	32128-33	Nut - Flange Lock	1
5	2412-89	Clamp - R	1
6	3230-23	Bolt - Carriage	4
7	3231-21	Bolt - Carriage	6
8	321-4	Screw - Cap Hex. Hd.	1
9	55-7290	Battery	1
10	19-4050	Knob	2
11	36-3400	Decal - No Step	1

Ref. No.	Part No.	Description	No. Used
12	87-5130	Cover - Battery Base	1
13	3269-27	Rivet - Plastic	4
14	87-7620	Shield - Plastic	1
15	87-5120	Bracket - Battery Base	1
16	323-9	Screw - Cap Hex. Hd.	1
17	3256-24	Washer - Flat	2
18	32128-20	Nut - Flange Lock	2
19	87-5110	Support - Lower	1
20	3296-39	Nut - Flange Lock	1
21	87-7600	Rod - Battery Support	1

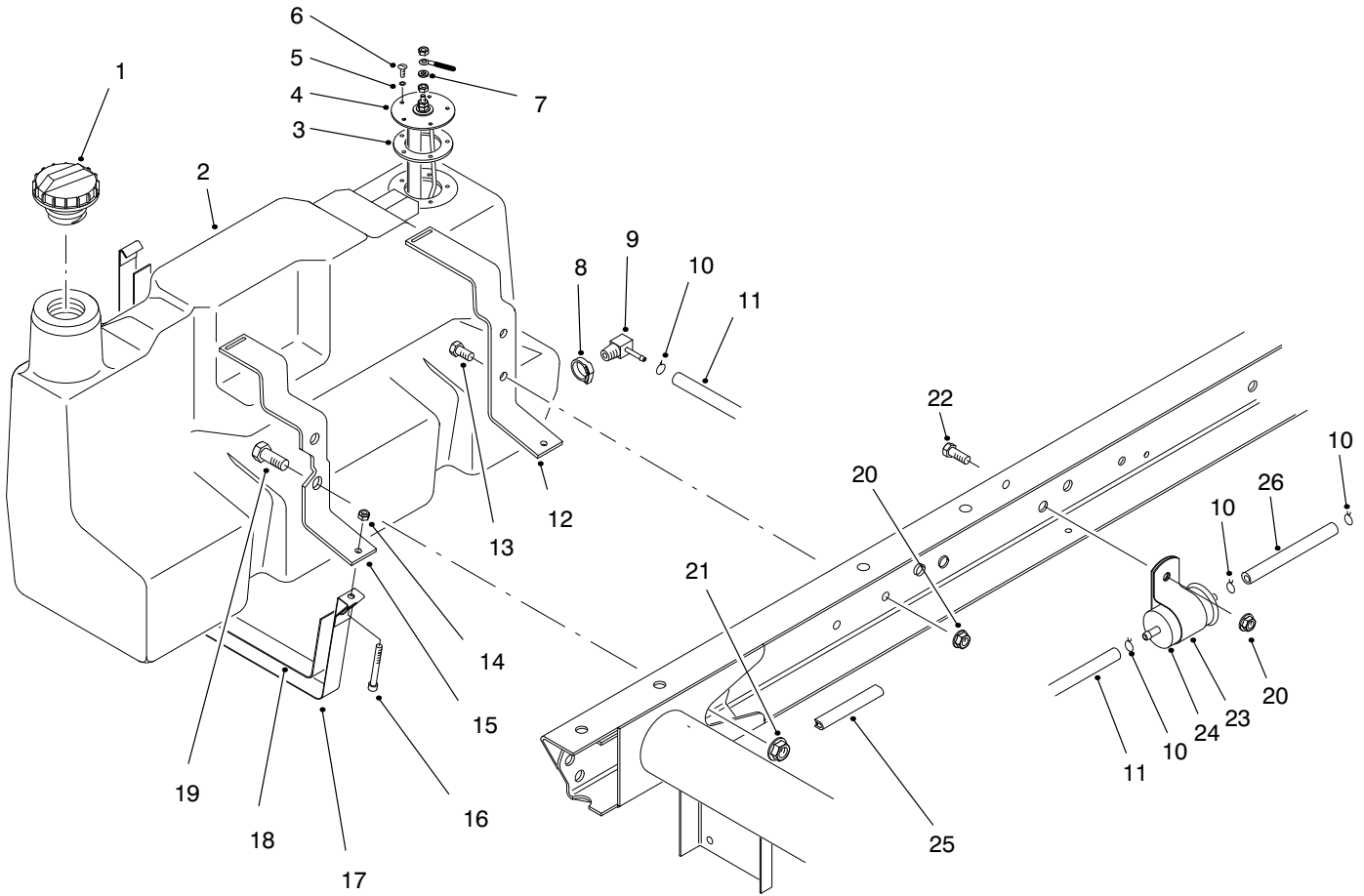

T-1737-1

FUEL TANK ASSEMBLY

Ref. No.	Part No.	Description	No. Used
1	93-3101	Cap - Fuel	1
2	98-2919	Fuel Tank Assembly (Incl. Ref. #8 & 9)	1
3	62-7650	Gasket - Sending Unit	1
4	63-7640	Unit - Sending	1
5	3253-15	Washer - Lock	5
6	32122-24	Screw - Round Hd.	5
7	5-3637	Washer - Flat	1
8	2412-36	Clamp	1
9	76-4430	Fitting - Fuel 90°	1
10	2412-108	Clamp - Hose	4
11	63-9640	Hose - Fuel	1
12	87-3140	Support - Rear	1
13	323-4	Screw - Cap Hex. Hd.	2

Ref. No.	Part No.	Description	No. Used
14	3296-42	Nut - Lock	2
15	87-3150	Support - Front	1
16	3274-54	Screw - Hex. Socket Hd.	2
17	87-3160	Strap - Tank Support	2
18	87-3170	Pad - Tank Support Strap	2
19	3234-38	Screw - Cap Hex. Hd.	2
20	3290-357	Nut - Flange	3
21	32128-23	Nut - Flange	2
22	323-6	Screw - Cap Hex. Hd.	1
23	2412-96	Clamp - R	1
24	18-1520	Filter - Fuel	1
25	43-4300	Trim	1
26	63-7622	Hose - Fuel	1

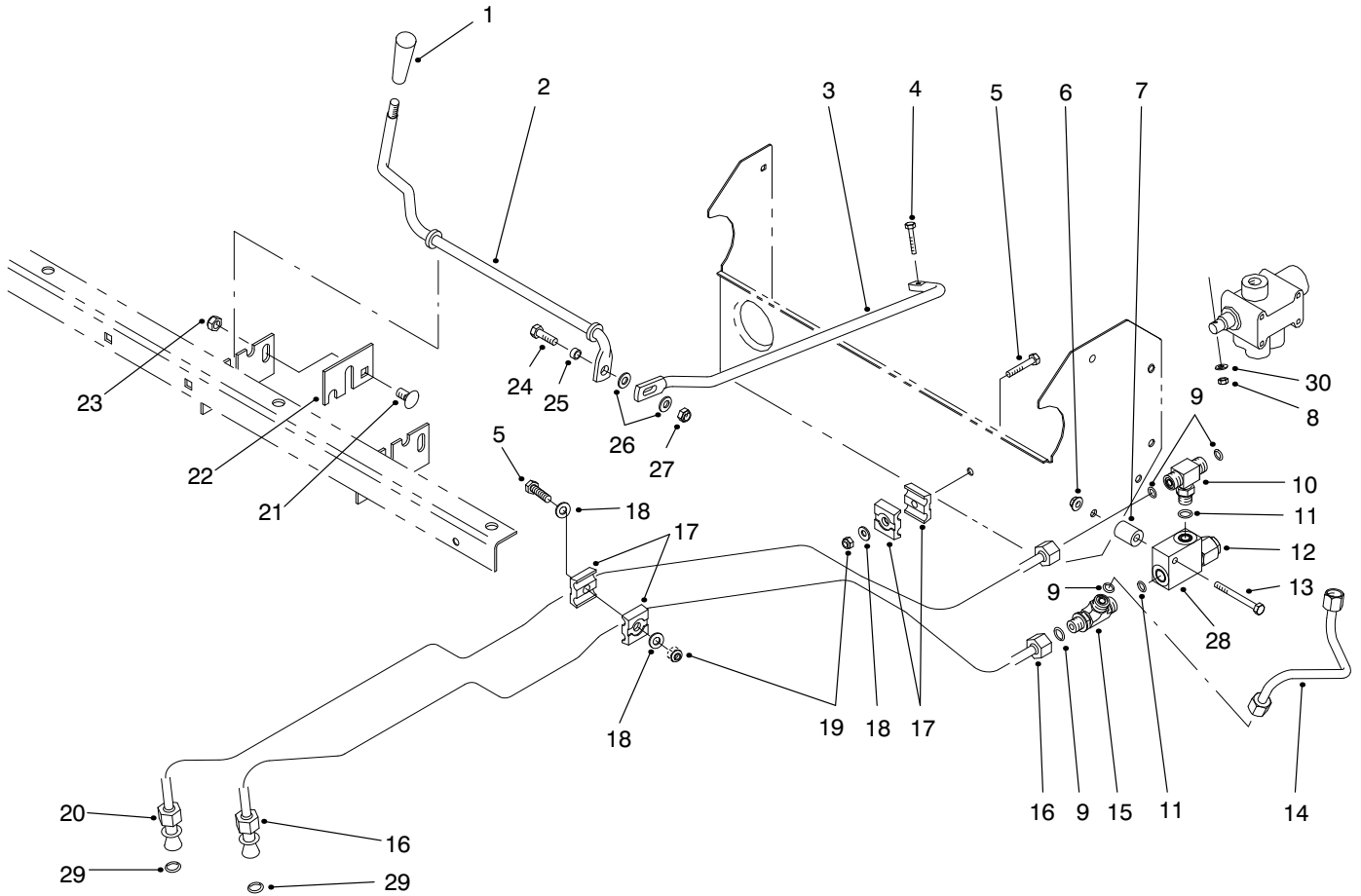

T-1610-1

LIFT VALVE LINKAGE ASSEMBLY

Ref. No.	Part No.	Description	No. Used
1	233-39	Knob	1
2	87-4500	Rod - Pivot	1
3	87-4510	Rod - Connecting	1
4	87-5150	Screw - Cap Hex. Hd.	1
5	321-9	Screw - Cap Hex. Hd.	2
6	32128-33	Nut - Flange Lock	1
7	75-9610	Spacer	1
8	87-5140	Nut - Lock	1
9	237-22	Seal - O-Ring	4
10	340-94	Fitting - Hydraulic Tee (Incl. Ref. #9 & 11)	1
11	237-42	Seal - O-Ring	2
12	92-2160	Cartridge - Relief Valve	1
13	321-15	Screw - Cap Hex. Hd.	1
14	87-4560	Tube - Hydraulic	1
15	340-86	Fitting - Hydraulic Tee (Incl. Ref. #9 & 11)	1
16	87-9350	Hydraulic Tube Assembly (Incl. Ref. #29)	1

Ref. No.	Part No.	Description	No. Used
17	56-7973	Clamp - Hydraulic Tube	4
18	3256-22	Washer - Flat	3
19	3296-42	Nut - Lock	2
20	87-4540	Hydraulic Tube Assembly (Incl. Ref. #29)	1
21	3231-21	Bolt - Carriage	2
22	87-4490	Bracket - Hold-Down	2
23	3296-39	Nut - Lock	2
24	322-5	Screw - Cap Hex. Hd.	1
25	87-5080	Spacer - Connecting	1
26	3256-23	Washer - Flat	2
27	3296-29	Nut - Lock	1
28	92-2161	Body - Relief Valve	1
29	39-7310	Seal - O-Ring	2
30	3256-14	Washer - Flat	1
*	87-3680	Relief Valve Assembly (Incl. Ref. #12 & 28)	1

*Not Illustrated

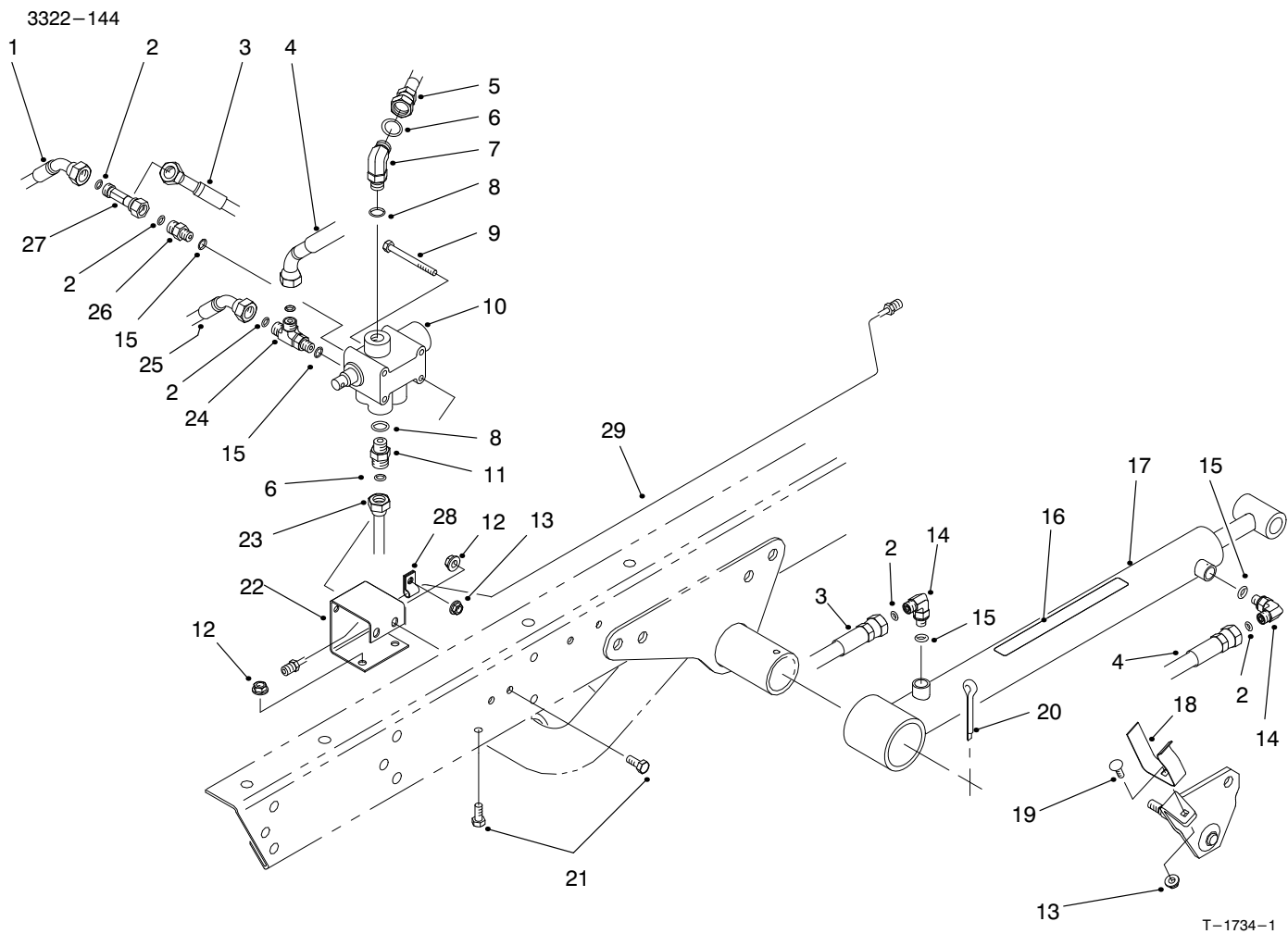

LIFT VALVE & CYLINDER ASSEMBLY

Ref. No.	Part No.	Description	No. Used
1	87-4900	Hose - Hydraulic	1
2	237-21	Seal - O-Ring	6
3	87-4880	Hose - Hydraulic	1
4	92-2697	Hose - Hydraulic	1
5	87-8020	Hose - Hydraulic	1
6	237-22	Seal - O-Ring	2
7	340-77	Fitting - Hydraulic 90° (Incl. Ref. #6 & 8)	1
8	237-42	Seal - O-Ring	2
9	321-14	Screw - Cap Hex. Hd.	2
10	43-1950	Valve	1
11	340-2	Fitting - Straight	1
12	32128-20	Nut - Flange Head	4
13	32128-33	Nut - Flange Head	4
14	340-132	Fitting - Hydraulic 90° (Incl. Ref. #2 & 15)	4
15	237-78	Seal - O-Ring	4
16	87-7930	Decal - Warning	2

Ref. No.	Part No.	Description	No. Used
17	94-5203	Hydraulic Cylinder Assy. (Incl. Ref. #16)	2
18	87-3720	Retainer - Cylinder	2
19	3229-1	Screw - Carriage	2
20	3272-37	Pin - Cotter	2
21	322-3	Screw - Cap Hex. Hd.	4
22	87-4520	Bracket - Dump Valve	1
23	87-4560	Hose - Hydraulic	1
24	340-140	Fitting - Hydraulic Tee (Incl. Ref. #2 & 15)	1
25	87-4910	Hose - Hydraulic	1
26	340-92	Fitting - Hydraulic Straight (Incl. Ref. #2 & 15)	1
27	340-151	Fitting - Hydraulic Tee (Incl. Ref. #2)	1
28	2412-149	Clamp - R	1
29	94-3844	Tube - Brake Line	1

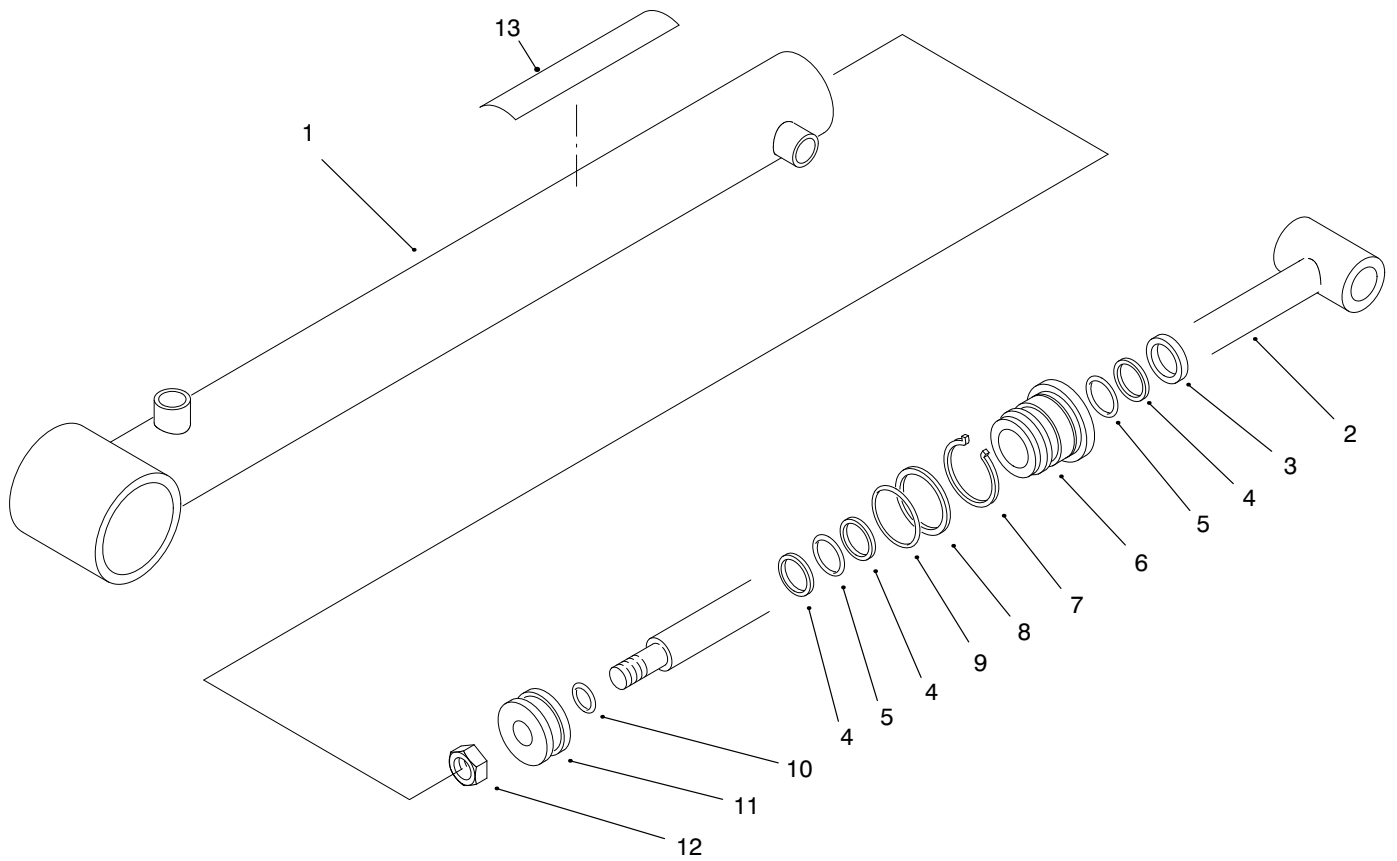

T-2342-1

LIFT CYLINDER NO. 94-5203

Ref. No.	Part No.	Description	No. Used
1	94-5206	Barrel Assembly	1
2	94-5207	Shaft	1
3		Seal - Dust	1
4		Backup	1
5		Seal - O-Ring	1
6	92-2162	Head	1
7	84-1680	Ring - Retaining	1
8		Backup	3

Ref. No.	Part No.	Description	No. Used
9		Seal - O-Ring	2
10		Seal - O-Ring	1
11	43-5150	Piston	1
12	32152-10	Nut	1
13	87-7930	Decal - Warning	1
*	92-2165	Kit - Repair (Incl. Ref. #3-5 & 8-10)	1

*Not Illustrated

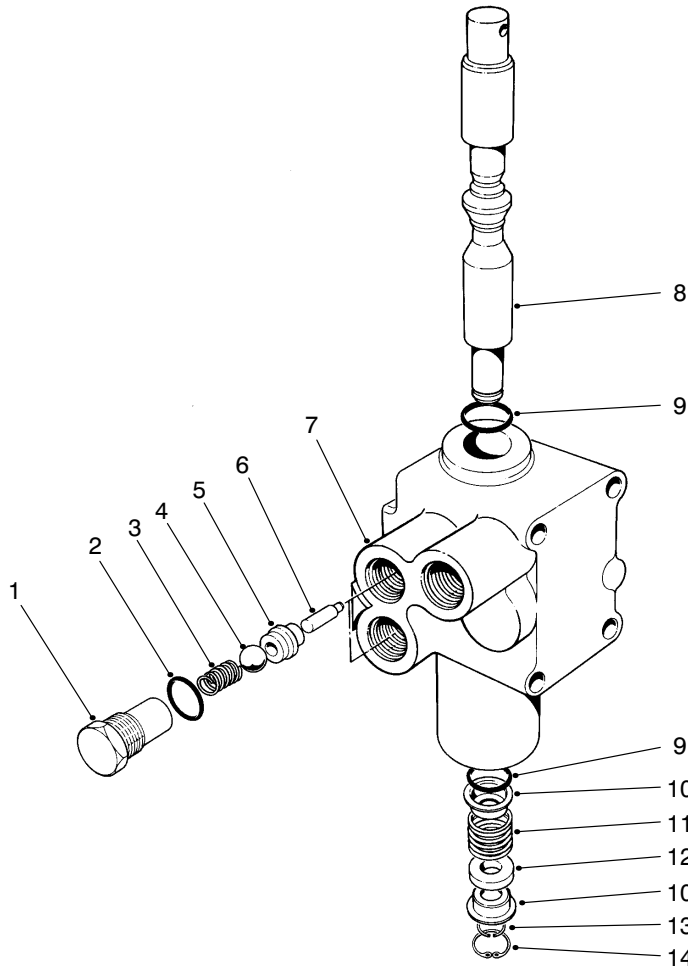

T-0280-1

CONTROL VALVE ASSEMBLY NO. 43-1950

Ref. No.	Part No.	Description	No. Used
1	22-8330	Plug	2
2	237-42	O-Ring	2
3	22-8340	Spring	2
4	22-8350	Ball	2
5	22-8370	Seat-Check Valve	2
6	22-8360	Pin - Cam	2
7		Body	1

Ref. No.	Part No.	Description	No. Used
8	22-8420	Spool	1
9	22-8500	O-Ring	2
10	22-8380	Retainer - Spring	2
11	22-8410	Spring	1
12	23-3030	Spacer	1
13	22-8480	Ring - Retaining, Spool	1
14	22-8490	Ring - Retaining	1

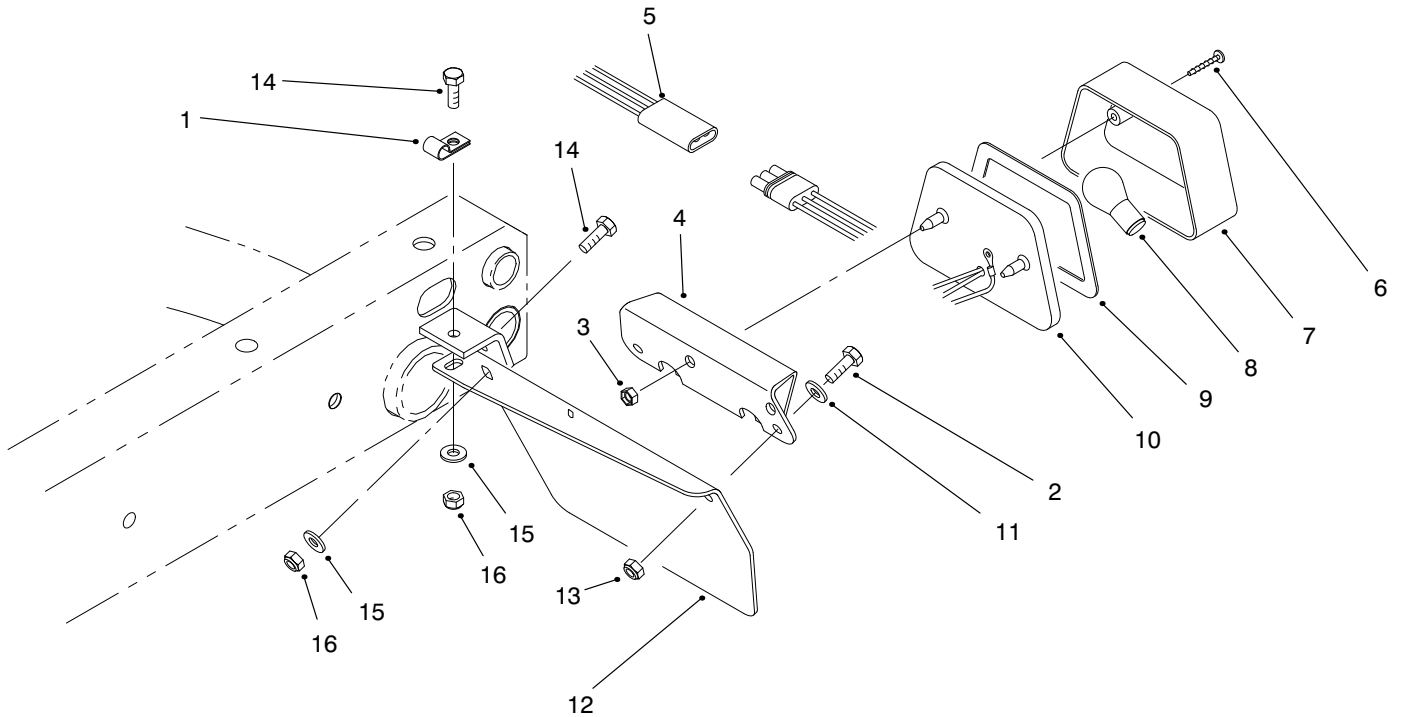

T-1805-1

TAIL LIGHT ASSEMBLY

Ref. No.	Part No.	Description	No. Used
1	2412-93	Clamp - R	1
2	321-6	Screw - Cap Hex. Hd.	2
3	3290-506	Palnut	2
4	87-5770	U-Bracket - Tail Light	1
5	87-8010	Harness - Wire Rear	1
6	32144-93	Screw - Self Tapping	2
7	87-6300	Lens	1
8		Bulb (#1157 Std. 12 Volt)	1

Ref. No.	Part No.	Description	No. Used
9	87-6310	Gasket	1
10	87-2110	Tail Light Assembly (Incl. Ref. #6-9)	1
11	3256-22	Washer - Flat	2
12	93-8943	Plate - Tail Light LH	1
13	3296-42	Nut - Lock	2
14	322-5	Screw - Cap Hex. Hd.	2
15	3256-23	Washer - Flat	2
16	3296-29	Nut - Lock	2

*Not Illustrated

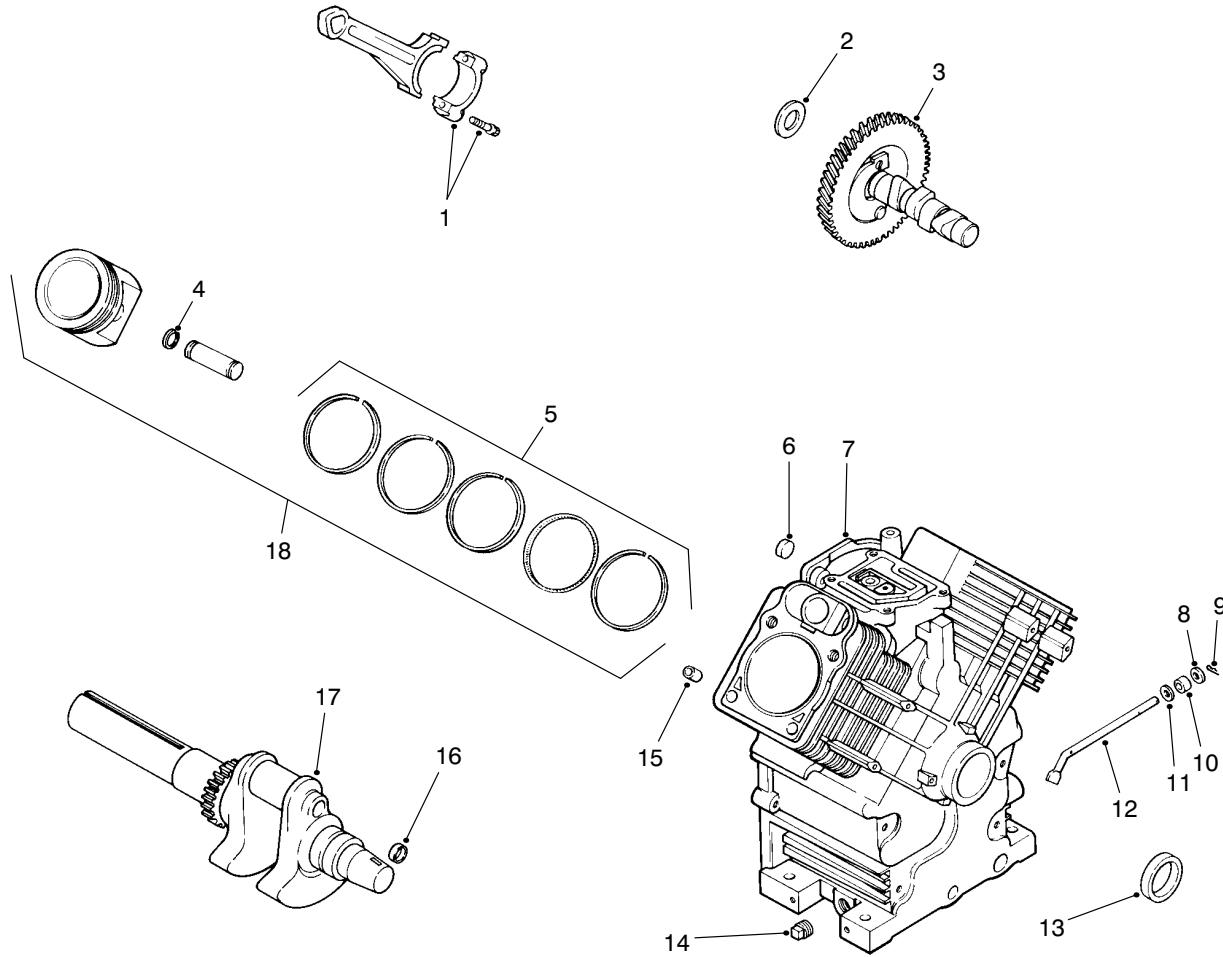

T-1819-1

ENGINE KOHLER MODEL CH22S SPEC. NO. 66513

Ref. No.	Part No.	Description	No. Used
1	24 067 01	Rod – Connecting (Std.)	2
*	24 067 02	Rod – Connecting (.25)	2
2	12 422 09	Shim – Camshaft	A/R
*	12 422 13	Shim – Camshaft	A/R
*	12 422 07	Shim – Camshaft	A/R
*	12 422 08	Shim – Camshaft	A/R
*	12 422 10	Shim – Camshaft	A/R
*	12 422 11	Shim – Camshaft	A/R
*	12 422 12	Shim – Camshaft	A/R
3	24 012 05	Camshaft	1
4	24 018 01	Retainer – Piston Pin	4
5	24 108 01	Piston Ring Set (Std.)	2
*	24 108 02	Piston Ring Set (.25)	2
*	24 108 03	Piston Ring Set (.50)	2
6	52 139 09	Plug – Cup	1
7	24 522 44	Short Block Assembly	1
8	X-25-102	Washer – Plain	1

Ref. No.	Part No.	Description	No. Used
9	12 380 04	Pin – Hitch	1
10	12 032 01	Seal – Governor Shaft	1
11	X-25-63	Washer – Plain	1
12	24 144 01	Shaft – Governor Cross	1
13	24 032 01	Seal – Oil	1
14	X-27-10	Plug – Square Hd.	2
15	12 380 03	Pin – Dowel	6
16	52 139 09	Plug – Cup	1
17	24 014 26	Crankshaft	1
18	24 874 01	Piston & Ring Set (Std.) (Incl. Ref. #4 & 5)	2
*	24 874 02	Piston & Ring Set (.25) (Incl. Ref. #4 & 5)	2
*	24 874 03	Piston & Ring Set (.50) (Incl. Ref. #4 & 5)	2
*	24 755 03	Gasket Set	1

*Not Illustrated

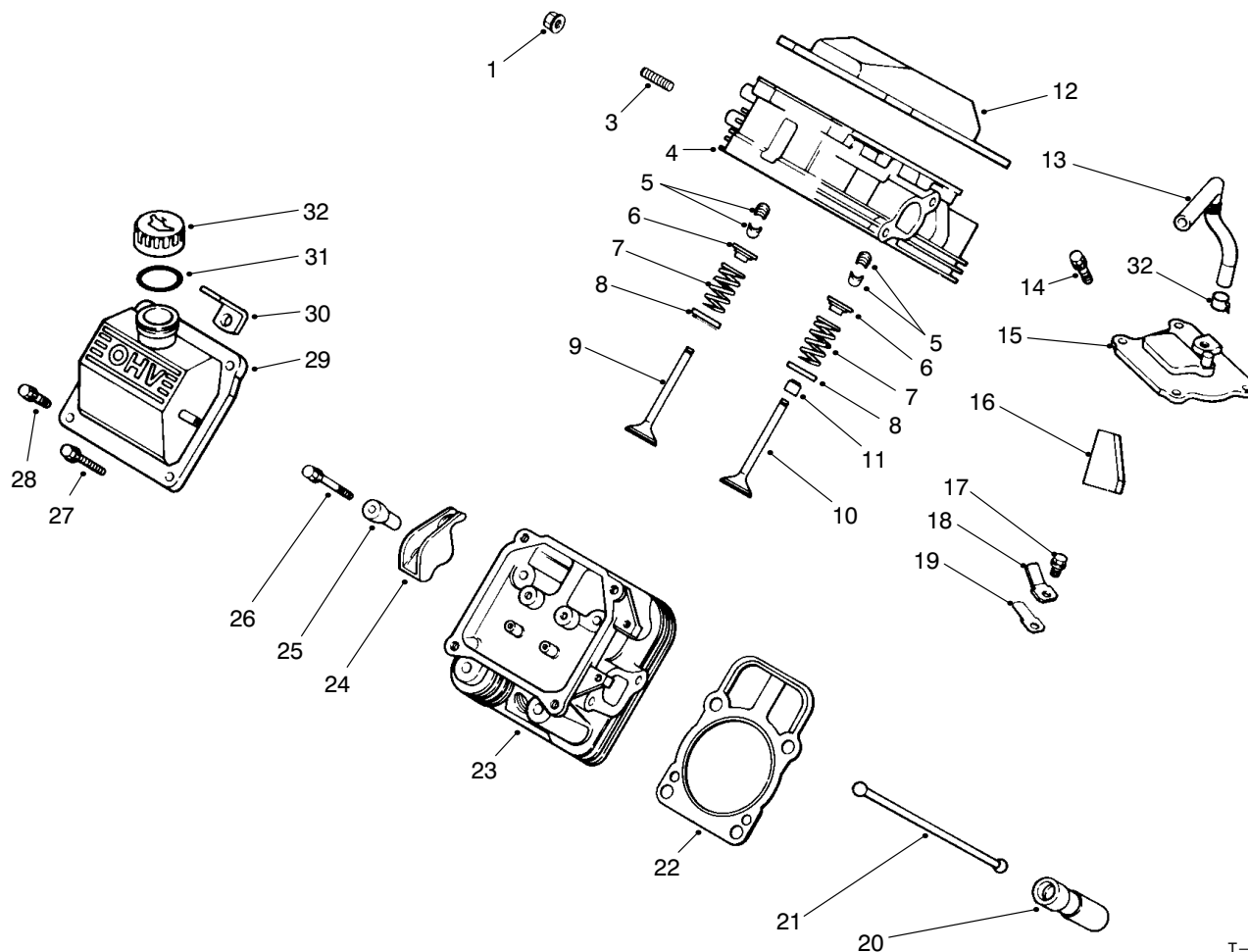

T-1820-1

ENGINE KOHLER MODEL CH22S SPEC. NO. 66513 (Cont.)

Ref. No.	Part No.	Description	No. Used	Ref. No.	Part No.	Description	No. Used
1	M-0841080	Nut	4	19	24 402 03	Reed - Breather	1
3	M-0829033	Stud - Exhaust Manifold	4	20	12 351 01	Lifter - Valve	4
4	24 318 09	No. 1 Cylinder Head Assy.	1	21	24 411 02	Rod - Push	4
5	12 755 03	Retainer Kit	4	22	24 041 08	Gasket - Cylinder Head	2
6	12 173 01	Cap - Valve Spring	4	23	24 318 10	No. 2 Cylinder Head Assy.	1
7	24 089 02	Spring - Valve	4	24	24 186 02	Arm - Rocker	2
8	52 018 01	Retainer - Spring	4	25	24 194 01	Ball - Pivot Rocker	2
9	24 016 01	Valve - Exhaust	2	26	M-0640034	Screw	1
10	24 017 01	Valve - Intake	2	27	12 086 16	Screw	8
11	24 032 05	Seal - Valve Stem	2	28	M-0651030	Screw	8
12	24 096 11	Cover - Rocker	1	29	24 096 12	Cover - Rocker	1
13	24 326 02	Hose - Breather	1	30	12 445 05	Strap - Lifting	2
14	SM-0645020	Screw	4	31	12 153 03	Seal - O-Ring	1
15	24 033 01	Breather & Plug Kit	1	32	24 755 46	Oil Fill Cap Kit (Incl. Ref. #31)	1
16	24 050 01	Filter - Breather	1	33	X-426-9	Clamp - Breather	1
17	M-0545010	Screw - Breather	1				
18	12 018 01	Retainer - Breather Reed	1				

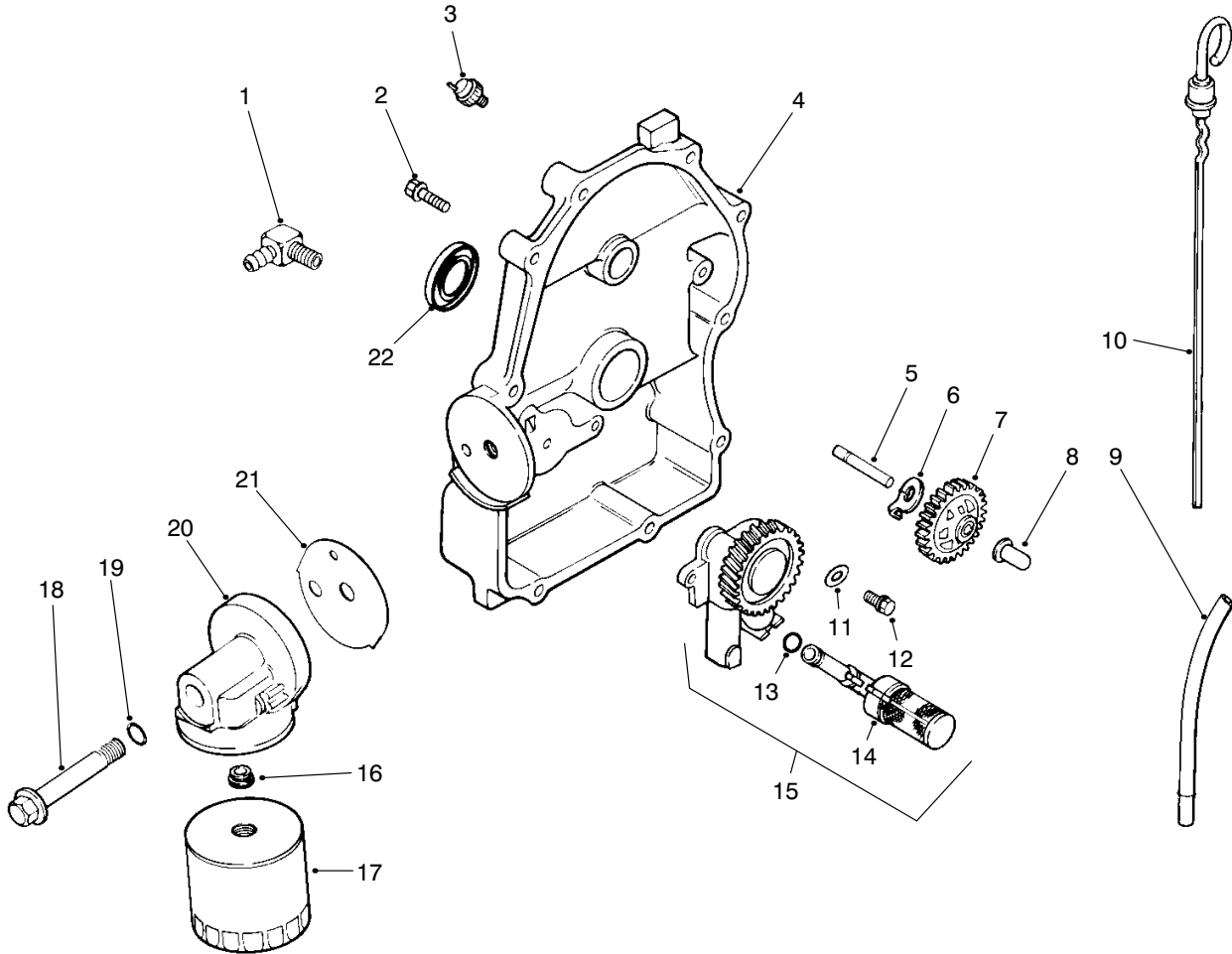

T-1821-1

ENGINE KOHLER MODEL CH22S SPEC. NO. 66513 (Cont.)

Ref. No.	Part No.	Description	No. Used
1	25 155 02	Connector - 90° Hose	1
2	24 086 16	Screw - Plate	10
3	52 099 06	Switch - Oil Pressure	1
4	24 009 04	Plate - Closure	1
5	12 144 02	Shaft - Governor Gear	1
6	52 448 02	Tab - Locking	1
7	24 043 11	Governor Gear Assy.	1
8	12 380 01	Pin - Governor Regulating	1
9	24 123 09	Tube - Dipstick	1
10	24 038 07	Dipstick	1
11	SM-0631005	Washer - Flat	2
12	M-0645025	Screw	2

Ref. No.	Part No.	Description	No. Used
13	24 153 01	Seal - O-Ring	1
14	24 381 01	Pick-Up - Oil	1
15	24 393 03	Oil Pump Assembly (Incl. Ref. #13 & 14)	1
16	24 136 01	Nipple - Oil Filter	1
17	12 050 01	Filter - Oil	1
18	24 211 01	Bolt - Adaptor	1
19	24 153 01	Seal - O-Ring	1
20	24 029 01	Adaptor - Oil Filter	1
21	24 041 12	Gasket - Adaptor	1
22	52 032 08	Seal - Oil	1
*	25 113 05	Decal - Oil Sentry	1

*Not Illustrated

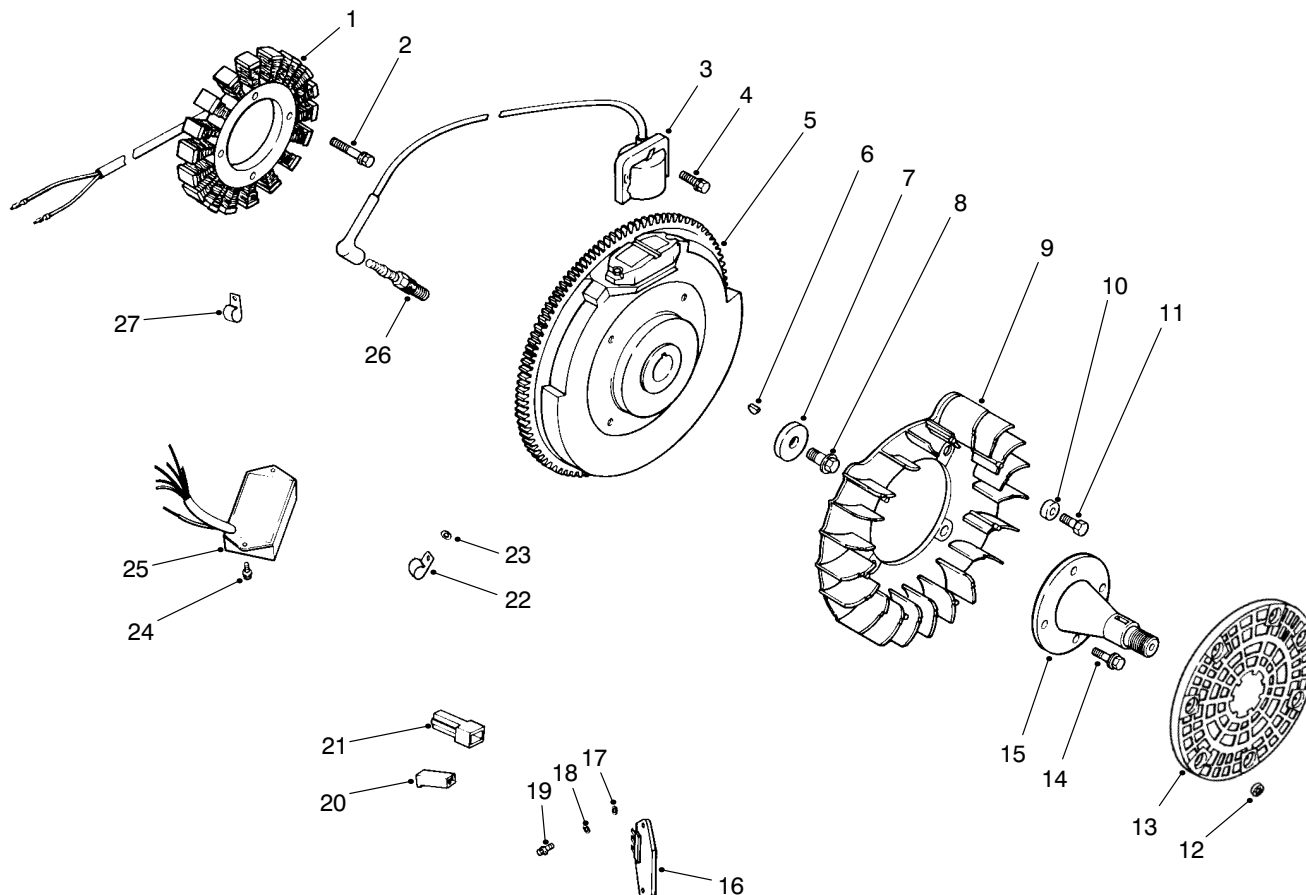

T-1822-1

ENGINE KOHLER MODEL CH22S SPEC. NO. 66513 (Cont.)

Ref. No.	Part No.	Description	No. Used	Ref. No.	Part No.	Description	No. Used
1	12 085 02	Stator - 30 Amp.	1	16	25 403 01	Rectifier/Regulator 25 Amp.	1
2	M-0548025	Screw	2	17	X-25-92	Washer - Plain	2
3	24 584 03	Module - Ignition	2	18	X-25-63	Washer - Plain	1
4	M-0560020	Screw	4	19	24 086 18	Screw - Phillips	2
5	24 025 02	Flywheel Assembly	1	20	25 155 04	Connector - 1 Contact	1
6	X-42-15	Key	1	21	25 155 03	Connector - 1 Contact	1
7	12 468 03	Washer - Flywheel	1	22	47 154 01	Clip - Cable	1
8	12 086 14	Screw - Flywheel	1	23	X-25-63	Washer - Plain	1
9	24 157 01	Fan	1	24	M-0448010	Screw	2
10	12 112 01	Spacer - Fan	4	25	24 584 04	Module - Speed Advance	1
11	M-0639016	Screw	4	26	12 132 02	Plug - Spark	2
12	24 018 03	Retainer	3	27	48 154 02	Clip - Cable	1
13	24 162 16	Screen - Grass	1	*	24 176 28	Harness - Wire	1
14	M-0839025	Screw	4	*	24 518 04	Lead - Green (Rect.-Reg. 4" 18 Ga.)	1
15	24 144 17	Shaft - Front Drive	1				

*Not Illustrated

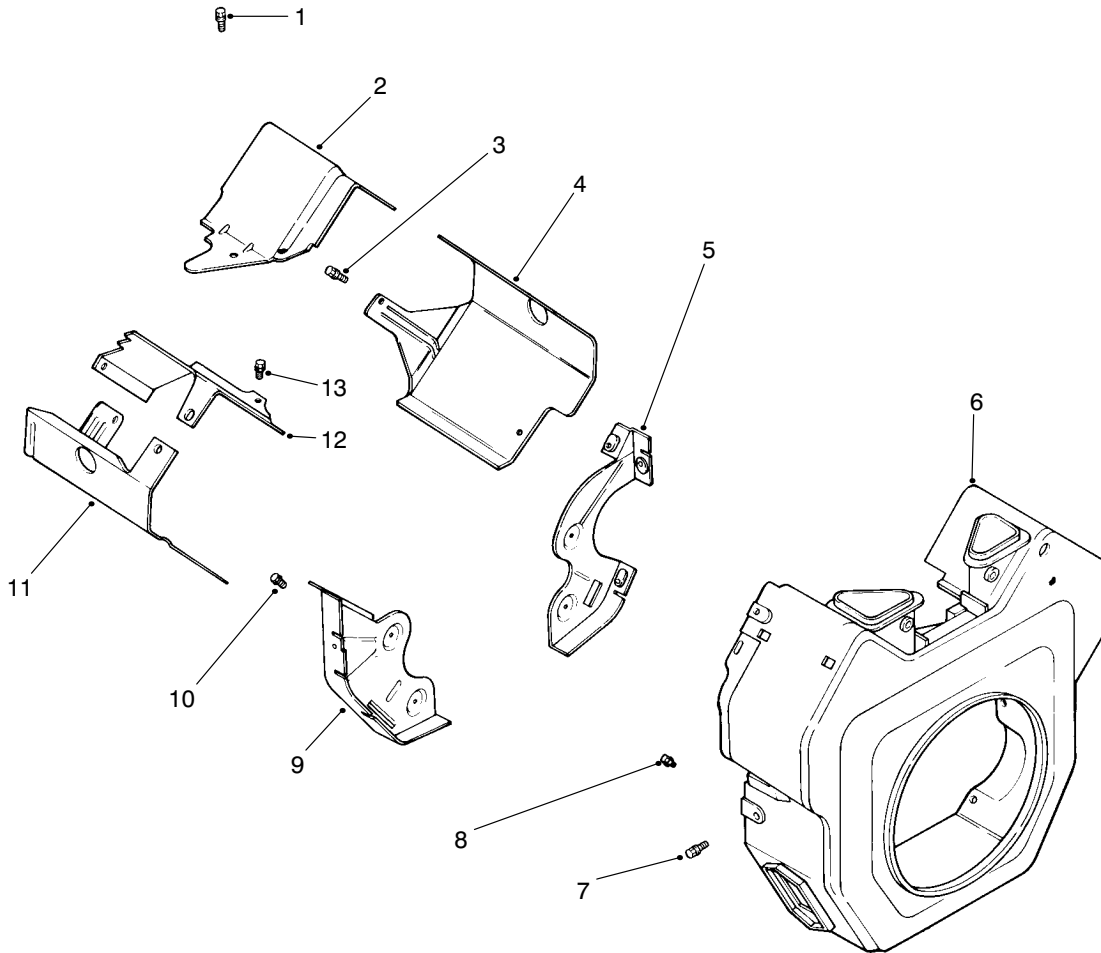

T-1823-1

ENGINE KOHLER MODEL CH22S SPEC. NO. 66513 (Cont.)

Ref. No.	Part No.	Description	No. Used
1	M-0549016	Screw	2
2	24 063 17	Baffle - Valley (No. 2 Side)	1
3	M-0549016	Screw	2
4	24 063 20	Baffle - Cylinder Barrel (No. 2 Side)	1
5	24 146 01	Plate - Backing (No. 1 Side)	1
6	24 027 04	Housing - Blower	1
7	M-0549016	Screw	5

Ref. No.	Part No.	Description	No. Used
8	M-0551016	Screw	1
9	24 146 02	Plate - Backing (No. 2 Side)	1
10	SM-0645016	Screw	4
11	24 063 19	Baffle - Cylinder Barrel (No. 1 Side)	1
12	24 063 18	Baffle - Valley (No. 1 Side)	1
13	M-0649016	Screw	2
*	24 113 13	Decal - Horsepower	1

*Not Illustrated

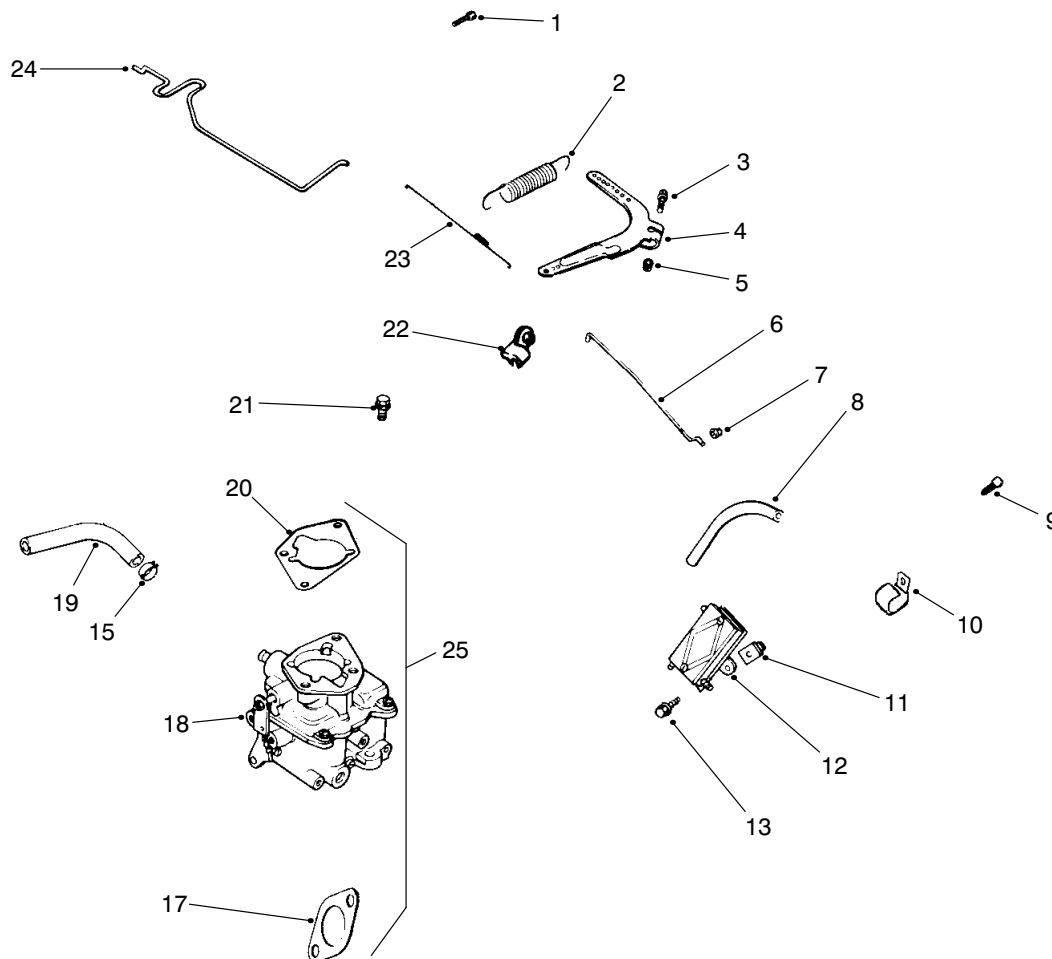

T-1824-1

ENGINE KOHLER MODEL CH22S SPEC. NO. 66513 (Cont.)

Ref. No.	Part No.	Description	No. Used	Ref. No.	Part No.	Description	No. Used
1	SM-0645016	Screw	4	15	X-426-9	Clamp - Hose	4
2	24 089 15	Spring - Governor	1	17	24 041 17	Gasket - Carburetor	1
3	SM-0642025	Screw	1	18	24 053 17	Carburetor Assembly (For information only, not available seperatly)	1
4	24 090 14	Lever - Governor	1	19	25 353 10	Line - Fuel 9"	1
5	SM-0641060	Nut	1	20	24 041 06	Gasket - Air Cleaner Base	1
6	24 079 01	Linkage - Throttle	1	21	M-0651030	Screw	2
7	25 158 08	Bushing - Linkage	1	22	25 158 11	Bushing - Linkage	1
8	24 353 02	Line - Fuel 15.5"	1	23	24 089 01	Spring - Linkage	1
9	M-0650012	Screw - Clip	1	24	24 079 05	Linkage - Choke	1
10	47 154 01	Clip - Cable	1	25	24 853 20	Carburetor & Gasket Kit (Incl. Ref. #17, 18 & 20)	1
11	24 100 01	Nut	2				
12	24 393 04	Pump - Fuel	1				
13	24 086 12	Screw	2				

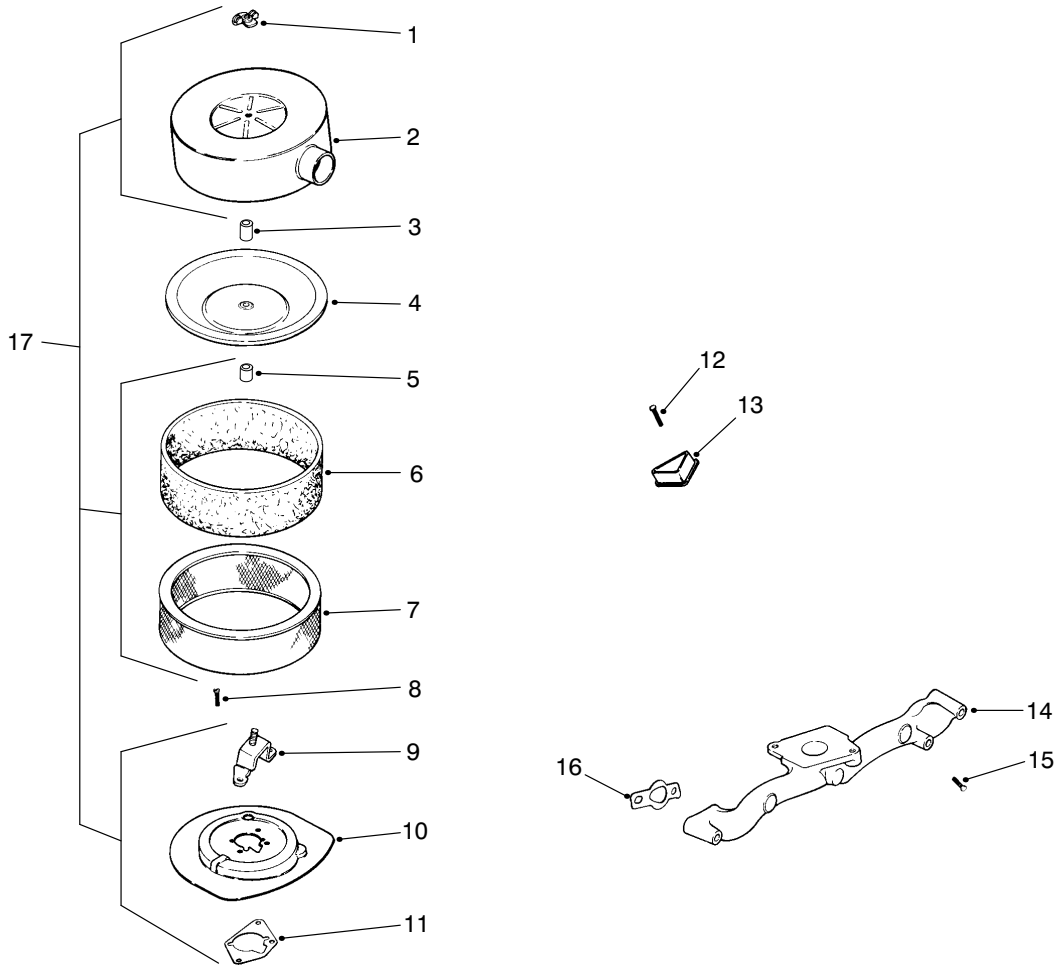

T-1825-1

ENGINE KOHLER MODEL CH22S SPEC. NO. 66513 (Cont.)

Ref. No.	Part No.	Description	No. Used
1	12 100 01	Nut – Wing	2
2	24 096 10	Cover – Air Cleaner	1
3	41 032 02	Seal – Insert	1
4	24 096 01	Cover – Inner Air Cleaner	1
5	230046	Seal – Air Intake	1
6	24 083 02	Element – Precleaner	1
7	47 083 03	Element – Air Cleaner	1
8	M-0650825	Screw	3
9	24 126 22	Bracket – Air Cleaner	1
10	24 041 06	Gasket – Air Cleaner Base	1

Ref. No.	Part No.	Description	No. Used
11	24 094 05	Base – Air Cleaner	1
12	15 086 09	Screw	2
13	24 096 17	Cover – Blower Housing	2
14	24 164 14	Manifold – Intake	1
15	M-0639055	Screw	4
16	24 041 01	Gasket – Intake Manifold	2
17	24 755 21	Grass Deflection Kit (Incl. Ref.#1, 2, 5-7 & 9-11)	1
*	24 113 14	Decal – Maintenance	1

*Not Illustrated

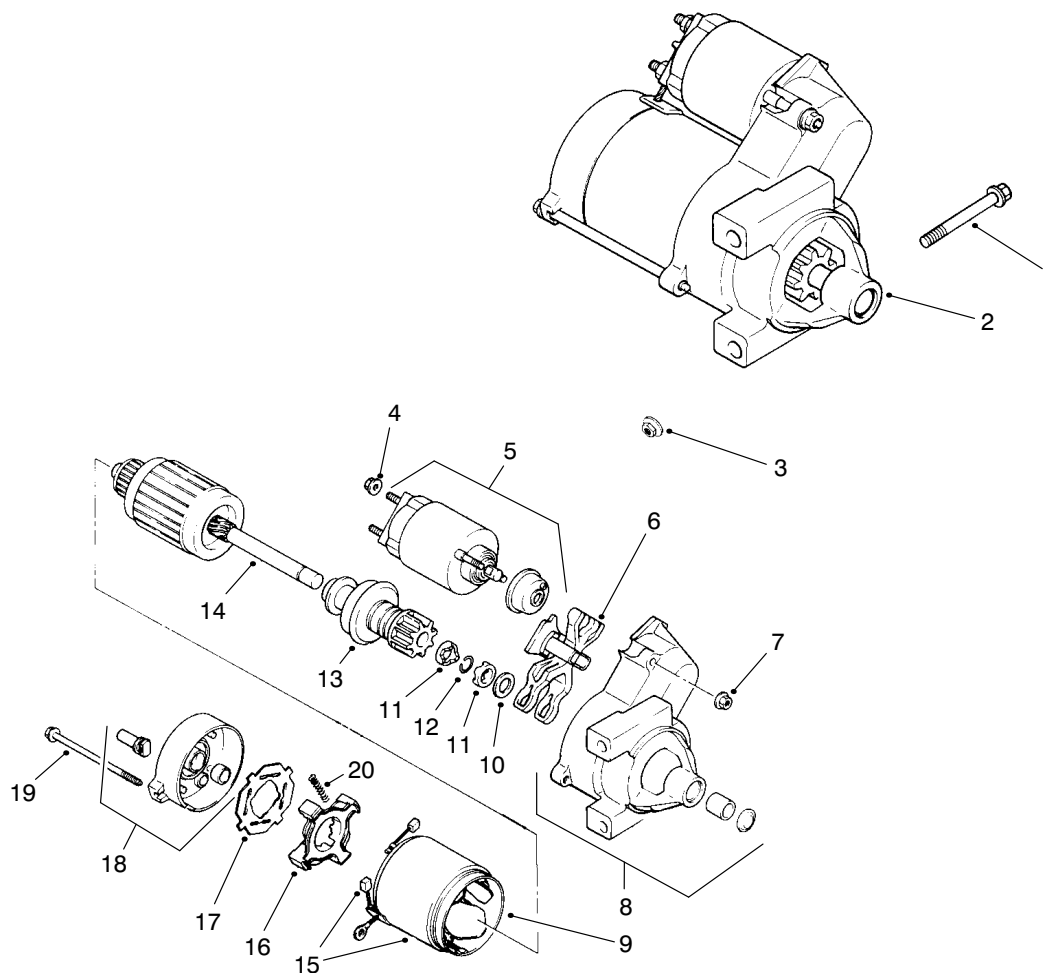

T-1826-1

ENGINE KOHLER MODEL CH22S SPEC. NO. 66513 (Cont.)

Ref. No.	Part No.	Description	No. Used	Ref. No.	Part No.	Description	No. Used
1	M-0839080	Screw	2	11	52 100 08	Nut - Stop Collar	2
2	24 098 01	Starter - Solenoid Shift (Incl. Ref. #4-20)	1	12	52 141 03	Ring - Retainer	1
3	M-0841080	Nut	1	13	12 239 01	Drive - Pinion	1
4	52 100 09	Nut - Starter	1	14	12 170 03	Armature - Starter	1
5	52 435 02	Solenoid	1	15	52 221 01	Brush Kit	1
6	12 090 10	Lever - Starter Drive	1	16	52 323 03	Holder - Brush	1
7	52 100 10	Nut - Starter	2	17	52 168 01	Insulator	1
8	24 081 04	Drive - End Cap	1	18	24 301 01	Commutator - End Cap	1
9	12 471 01	Frame	1	19	52 211 05	Bolt - Thru	2
10	52 468 14	Washer - Thrust	1	20	52 089 09	Spring - Brush	4

TORO PART NUMBER INDEX

Part No.	Description	Pg. No.	Ref. No.	Qty.	Part No.	Description	Pg. No.	Ref. No.	Qty.
111071	Bumper	13	4	2	54-0110	Element - Oil Filter	30	38	1
116749	Horn Assembly	1	21	1	55-7120	Switch - Brake Light	7	32	1
146489	Rivet - Pop	1	28	8	55-7290	Battery	37	9	1
5-3637	Washer - Flat	38	7	1	56-2150	Screw - Cap Hex. Hd.	27	8	4
7-0030	Bolt - Shoulder	28	1	1	56-2150	Screw - Cap Hex. Hd.	11	13	4
18-1520	Filter - Fuel	38	24	1	56-7973	Clamp - Hydraulic Tube	39	17	4
18-1720	Joint - Ball	28	15	1	60-6750	Screw - Cap Hex. Hd.	32	4	11
18-2830	Horn Switch Assembly	2	30	1	60-9920	Screw - Cap Hex. Hd.	11	9	2
18-4260	Screw/Lockwasher Assy.	5	9	2	62-5550	Decal - TORO	1	2	1
18-4270	Clamp - Ball Return Guide	5	8	1	62-7650	Gasket - Sending Unit	38	3	1
18-4340	Plug - Rack Piston End	5	6	1	63-7622	Hose - Fuel	38	26	1
18-5170	Seal Kit - Valve Ring	6	*	1	63-7640	Unit - Sending	38	4	1
18-5180	Bearing Kit - Lower Thrust	6	*	1	63-8360	Key - Ignition	2	11	1
18-5190	Kit - Ball, Recirculating	5	10	1	63-9640	Hose - Fuel	38	11	1
19-4050	Knob	37	10	2	65-5220	Screw - Hex. Socket Hd.	14	40	3
21-0360	Nut	8	6	1	65-5360	Spring - Extension	4	35	1
21-9260	Spacer	4	4	1	66-6840	Decal - Caution	21	32	1
22-8330	Plug	42	1	2	66-6840	Decal - Hot Surface	11	43	1
22-8340	Spring	42	3	2	67-1450	Spring - Extension	28	5	1
22-8350	Ball	42	4	2	68-3840	Ball Joint	7	23	1
22-8360	Pin - Cam	42	6	2	68-3841	Ball Joint Assembly	7	45	1
22-8370	Seat-Check Valve	42	5	2	68-9950	Spring - Extension	30	44	1
22-8380	Retainer - Spring	42	10	2	70-1480	Relay	29	2	2
22-8410	Spring	42	11	1	71-5320	Washer - Flat	15	18	1
22-8420	Spool	42	8	1	72-4310	Switch - Ball N.C.	30	46	1
22-8480	Ring - Retaining, Spool	42	13	1	74-0720	Tube - Manual	13	1	1
22-8490	Ring - Retaining	42	14	1	75-6820	Hourmeter	2	18	1
22-8500	O-Ring	42	9	2	75-9610	Spacer	39	7	1
23-3030	Spacer	42	12	1	76-2290	Spacer	15	37	1
23-7270	Nut - Lug	19	4	10	76-4430	Fitting - Fuel 90°	38	9	1
23-7270	Nut - Lug	22	18	10	76-9100	Spacer	25	24	6
26-0071	Bumper	1	9	2	76-9100	Spacer - Hi-Lo Lever	14	35	1
27-2360	Ignition Switch Assembly	2	33	1	76-9430	Spring - Extension	7	28	1
28-0540	Bolt - Shoulder	7	46	1	80-6990	Washer	22	39	4
28-8200	O-Ring	5	27	1	80-6990	Washer - Flat	30	49	3
28-8210	Bolt - Flange Hex. Hd.	5	17	4	80-8040	Decal - Warning	27	22	1
28-8220	Nut - Lash Adjuster	5	16	1	84-1680	Ring - Retaining	41	7	1
28-8270	Seal Service Kit - End Plug	6	*	1	87-0150	Tower - Control Arm RH	17	9	1
28-8280	Seal Kit - Side Cover	5	14	1	87-0160	Tower - Control Arm LH	17	*	1
28-8290	Seal Service Kit	6	*	1	87-0210	Arm - Control Lower RH	18	18	1
33-3090	Bushing - Flange	17	7	4	87-0220	Arm - Control Lower LH	18	*	1
36-3400	Decal - No Step	37	11	1	87-0270	Drum - Brake	19	7	2
39-7310	O-Ring	5	35	3	87-0370	Arm - Pitman	4	21	1
39-7310	Seal - O-Ring	39	29	2	87-0690	Spring - Compression	17	15	2
39-7420	Washer - Lock	4	22	1	87-0710	Hood	1	1	1
39-7420	Washer - Lock	5	42	1	87-0740	Key - Supervisor Switch	2	19	1
39-7440	Nut - Lock	4	23	1	87-1430	Joint - Ball	18	16	4
39-7440	Nut - Pitman Arm	5	41	1	87-1450	Bushing - Rubber	18	1	8
42-3560	Screw - Shoulder	15	15	1	87-1470	Rod End Assy. - LH Thread	19	19	2
42-7160	Pin - Dowel	27	17	3	87-1480	Rod End Assy. - RH Thread	19	24	2
42-9530	Screw - Cap Hex. Hd.	32	10	25	87-1490	Spring - Leaf	21	15	2
42-9850	Washer - Lock	11	20	12	87-1500	Steering Gear (Complete)	6	*	1
42-9850	Washer - Lock	35	21	3	87-1500	Steering Gear Assembly	4	20	1
42-9850	Washer - Lock	32	32	42	87-1720	Nut - Supervisor Switch	2	20	1
43-1950	Valve	40	10	1	87-1840	Drum - Brake	22	15	2
43-4300	Trim	38	25	1	87-1910	Pin - Alignment	11	14	2
43-5150	Piston	41	11	1	87-1920	Seal - Shaft	11	6	2
43-6550	Ring - Retaining	4	10	2	87-1970	Bearing - Matched Set	23	*	2
44-0760	Decal - Warning	17	33	2	87-2040	Lever - Shift	14	16	1
48-7560	Screw - Cap Hex. Hd.	32	24	1	87-2080	Stud - Drive	22	12	10
48-7700	Screw - Cap Hex. Hd.	35	9	3	87-2100	Bearing - Release	11	26	1
48-7730	Screw - Cap Hex. Hd.	32	18	5	87-2110	Tail Light Assembly	43	10	1
48-7740	Screw - Cap Hex. Hd.	4	15	4	87-2120	Headlight Assembly	1	3	2
48-7930	Nut - Hex.	32	2	1	87-2240	Housing - Axle	22	7	2
48-8070	Washer - Flat	4	6	1	87-2260	Boot - Shift Lower	14	28	1
48-9520	Nut - Lock	21	28	2	87-2280	Bearing	4	25	3
48-9520	Nut - Lock	30	50	3	87-2310	Clevis - Cable	30	36	3
49-9150	Washer - Flat	15	2	1	87-2410	Rod - Tie	19	17	2
49-9150	Washer - Flat	14	36	1	87-2420	Boot	18	19	4

*Not Illustrated

TORO PART NUMBER INDEX (Cont.)

3322-144

Part No.	Description	Pg. No.	Ref. No.	Qty.	Part No.	Description	Pg. No.	Ref. No.	Qty.
87-2440	Bumper	1	7	2	87-3920	Bushing - Rubber	17	4	24
87-2480	Link - Stabilizer	17	24	2	87-3920	Bushing - Rubber	21	7	8
87-2500	Sleeve - Spring Pivot	17	12	2	87-3940	Mount - Spring RH	21	*	1
87-2510	Bracket - Seat Frame	13	11	2	87-3960	Mount - Spring LH	21	18	1
87-2520	Tube - Pivot	14	21	1	87-3980	Shackle - Spring	21	11	4
87-2710	Lever - Parking Brake	15	29	1	87-3990	Oil Strainer Assembly	30	26	1
87-2790	Tube - Brake LH	18	*	1	87-4010	Clamp - Anti-Sway Bar	17	20	2
87-2800	Tube - Brake RH	18	20	1	87-4060	Spacer - Bearing	22	21	2
87-2820	Bracket - Hose	19	15	2	87-4070	Bumper - Front	1	14	1
87-2870	Bracket - Brake Hose	18	4	2	87-4080	Tube - Brake LH	22	6	1
87-2880	Shaft - Accelerator Pedal	7	6	1	87-4090	Tube - Brake RH	22	1	1
87-2900	Spring - Compression	14	24	1	87-4100	Hose - Brake	22	3	2
87-3000	Rim - Rear 23	22	19	2	87-4100	Hose - Brake	21	5	2
87-3010	Brake Assembly - RH	19	10	1	87-4230	Harness - Wire Front LH	2	46	1
87-3010	Front Brake Assembly - RH	20	*	1	87-4260	Cable Assembly	14	15	2
87-3020	Brake Assembly - LH	19	*	1	87-4260	Shift Cable Assembly	31	51	2
87-3020	Front Brake Assembly - LH	20	*	1	87-4340	Clamp - Cable	14	10	1
87-3040	Reservoir - Master Cylinder	8	1	1	87-4350	Lever - Hi-Lo	14	2	1
87-3060	Washer - Flat	22	25	2	87-4420	Hi-Lo Cable Assembly	14	6	1
87-3080	Cable - Battery Negative	25	14	1	87-4420	Hi-Lo Cable Assembly	31	52	1
87-3100	Lower Shaft Assembly	4	*	1	87-4460	Differential Lock Cable	15	11	1
87-3110	Absorber - Shock	17	29	2	87-4470	Bracket	30	23	1
87-3110	Shock Absorber	21	8	2	87-4490	Bracket - Hold-Down	39	22	2
87-3120	Steering Column & Shaft	4	*	1	87-4500	Rod - Pivot	39	2	1
87-3130	Lever - Tilt Steering	4	36	1	87-4510	Rod - Connecting	39	3	1
87-3140	Support - Rear	38	12	1	87-4520	Bracket - Dump Valve	40	22	1
87-3150	Support - Front	38	15	1	87-4540	Hydraulic Tube Assembly	39	20	1
87-3160	Strap - Tank Support	38	17	2	87-4560	Hose - Hydraulic	40	23	1
87-3170	Pad - Tank Support Strap	38	18	2	87-4560	Tube - Hydraulic	39	14	1
87-3250	Mount - Bearing	4	26	3	87-4710	Spacer - Parking Brake	15	13	1
87-3290	Tire - Rear 23	22	16	2	87-4720	Plate - Steering Boot	4	3	1
87-3310	Clip - Brake Cable	22	8	2	87-4730	Guard - Belly	25	26	2
87-3310	Clip - Brake Cable	19	25	2	87-4760	Bushing	21	12	12
87-3450	Plug	19	12	2	87-4820	Bracket - Cable	30	27	1
87-3460	Boot - Tilt Steering	4	2	1	87-4880	Hose - Hydraulic	40	3	1
87-3470	Bumper - Spring	21	14	2	87-4900	Hose - Hydraulic	40	1	1
87-3480	Plate - Brake Equalizer	15	22	1	87-4910	Hose - Hydraulic	40	25	1
87-3520	Clevis	14	27	1	87-4920	Hose - Hydraulic	30	41	1
87-3530	Button - Shifter	14	29	1	87-4960	Clamp - Cable	14	42	1
87-3540	Link - Shift	14	20	2	87-4970	Engine Mount Assembly	25	21	2
87-3560	Tee - Brake Line	9	18	1	87-4970	Transaxle Mount Assembly	30	18	4
87-3560	Tee - Brake Tube	21	23	1	87-5030	Lever - Differential Lock	15	3	1
87-3570	Fitting - Union	9	6	2	87-5060	Cushion - Seat Bottom	12	7	2
87-3570	Union - Brake	21	25	2	87-5080	Spacer - Connecting	39	25	1
87-3570	Union - Brake Line	7	5	2	87-5100	Washer	30	17	4
87-3580	Retainer	21	4	2	87-5100	Washer - Snubbing	25	20	2
87-3580	Retainer	19	14	2	87-5110	Support - Lower	37	19	1
87-3580	Retainer - Brake Hose	22	2	2	87-5120	Bracket - Battery Base	37	15	1
87-3580	Retainer - Brake Hose	18	3	2	87-5130	Cover - Battery Base	37	12	1
87-3580	Retainer - Brake Hose	9	8	2	87-5140	Nut - Lock	39	8	1
87-3590	Seal - Bearing	22	22	2	87-5150	Screw - Cap Hex. Hd.	39	4	1
87-3590	Seal - Bearing	19	26	2	87-5290	Shaft - Release	11	5	1
87-3600	Spacer	17	3	10	87-5300	Fork - Clutch	11	23	1
87-3610	Bracket - Detent	4	34	1	87-5320	Guide - Release	11	25	1
87-3650	Pin - Shift	14	18	1	87-5330	Washer	17	2	12
87-3660	Spring - Compression	14	30	1	87-5340	Seal Kit - Tie Rod End	19	*	1
87-3680	Relief Valve Assembly	39	*	1	87-5350	Bracket - Switch	11	18	1
87-3720	Retainer - Cylinder	40	18	2	87-5360	Lever	11	15	1
87-3750	Cover - Steering Wheel	4	9	1	87-5370	Rear Tire & Wheel Assembly	23	*	2
87-3760	Plate - Shift Boot	12	14	1	87-5490	Switch - Neutral	11	19	1
87-3770	Bushing - Sleeve	11	7	2	87-5520	Spindle - RH	19	13	1
87-3780	Box - Glove	2	3	1	87-5540	Spindle - LH	19	*	1
87-3790	Switch - Light	2	22	1	87-5560	Hub - Wheel	19	8	2
87-3800	Bracket - Seat Bottom	12	3	3	87-5580	Fuel Gauge Assembly	2	15	1
87-3820	Wheel - Steering	4	7	1	87-5700	Hydraulic Pump Assembly	25	6	1
87-3850	Bar - Anti-Sway	17	17	1	87-5720	Rim	19	6	2
87-3860	Link - Anti-Sway Bar	17	5	2	87-5730	Hose - Hydraulic	30	4	1
87-3890	Bracket - Anti-Sway Bar	17	18	2	87-5770	U-Bracket - Tail Light	43	4	1
87-3910	Bushing - Anti-Sway Bar	17	19	2	87-5800	Bracket - Mount	30	21	2

*Not Illustrated

TORO PART NUMBER INDEX (Cont.)

Part No.	Description	Pg. No.	Ref. No.	Qty.	Part No.	Description	Pg. No.	Ref. No.	Qty.
87-5910	Decal - Supervisor	2	16	1	87-7930	Decal - Warning	40	16	2
87-5920	Decal - Danger	12	26	1	87-7930	Decal - Warning	41	13	1
87-5930	Decal - Caution	12	10	1	87-7940	Stud	13	8	1
87-5940	Decal - Rollover	16	2	1	87-7950	Bed Support Assembly	13	7	1
87-5960	Decal - Axle Range	12	11	1	87-7960	Clamp - Shift Arm	30	48	2
87-5970	Decal - PTO	12	16	1	87-7970	Arm - Shift	30	15	1
87-5980	Decal - ROPS	16	3	2	87-7980	Bracket - Muffler	29	14	1
87-5990	Decal - PTO	22	40	1	87-8000	Cable - Battery Positive	27	24	1
87-6000	Decal - Differential Lock	12	17	1	87-8010	Harness - Wire Rear	43	5	1
87-6010	Decal - Dump Hydraulics	12	19	1	87-8020	Hose - Hydraulic	40	5	1
87-6020	Decal - Parking Brake	12	20	1	87-8020	Hose - Hydraulic	25	11	1
87-6030	Decal - Workman 3100	1	15	1	87-8030	Hose - Hydraulic	25	4	1
87-6040	Bracket - Shifter	14	22	1	87-8030	Hose - Hydraulic	31	54	1
87-6060	Decal - ATF	22	4	1	87-8060	Cable - Choke	28	3	1
87-6080	Washer	27	10	1	87-8060	Choke Control Assembly	12	27	1
87-6170	Frame - Seat	13	14	1	87-8080	Console Plate Assembly	12	21	1
87-6240	Bracket - Seat Back	13	23	4	87-8120	Bracket - Trim Side	1	11	2
87-6280	Plate - Seat Back	13	18	2	87-8130	Bracket - Trim Top	1	19	1
87-6290	Cushion - Seat Back	13	17	2	87-8160	Trim	1	20	1
87-6300	Lens	43	7	1	87-8170	Fitting - Hydraulic 90°	25	2	1
87-6310	Gasket	43	9	1	87-8200	Harness - Wire Front	2	41	1
87-6320	Bulb - Headlight	1	5	2	87-8240	Cable - Parking Brake	15	24	2
87-6330	Lens - Headlight	1	6	2	87-8240	Cable - Parking Brake	25	32	2
87-6370	Rear Tire & Wheel Assembly	23	*	2	87-8250	Plate - Shift Arm	30	10	1
87-6390	Adapter - Clutch	27	5	1	87-8360	Plug - Hole	2	10	2
87-6400	Frame - Engine	25	31	1	87-8370	Belt - V	25	29	1
87-6410	Bracket - Harness	11	11	1	87-8370	Belt - V	27	29	1
87-6460	Bearing - Pilot	27	12	1	87-8440	Rear Frame Assembly	21	2	1
87-6480	Flywheel	27	18	1	87-8460	Bumper	11	34	1
87-6570	Foam - Seal	14	38	1	87-8471	Bracket - Clutch	11	41	1
87-6620	Screw	1	10	15	87-8560	Control Panel Assembly	2	45	1
87-6620	Screw - Torx Pan Hd.	11	38	2	87-8580	Light - Indicator (Red)	2	7	1
87-6620	Screw - Torx Pan Hd.	7	43	2	87-8620	Boot - Shift	12	13	1
87-6640	Lever - Dump Stop	15	14	1	87-8640	Washer - Flat	29	8	4
87-6670	Decal - Fuse Block	2	40	1	87-8640	Washer - Flat	14	26	1
87-6710	Switch - Supervisor	30	33	1	87-8650	Gasket - Muffler	29	12	3
87-6720	Knob	14	17	1	87-8680	Plate - Muffler Mount	29	5	1
87-6750	Rim - Rear 24	22	*	2	87-8710	Tab - Clutch	11	40	1
87-6890	Hold - Hand	12	1	1	87-8730	Stud - Drive	19	9	10
87-6910	Spring - Compression	30	13	1	87-8770	Decal - Air Cleaner	27	4	1
87-6950	Receiver - LH	16	6	1	87-8780	Head - Oil Filter	30	43	1
87-6960	Receiver - RH	16	7	1	87-8790	Starter Cover Plate Assembly	11	10	1
87-7040	Bracket - Oil Filter	30	2	1	87-9080	Decal - Grease	22	44	2
87-7070	Skirt Assembly	12	2	1	87-9250	Transaxle Assembly	30	22	1
87-7090	R.O.P.S. Frame Assembly	16	1	1	87-9350	Hydraulic Tube Assembly	39	16	1
87-7110	Rear Axle Assembly	22	5	1	87-9480	Fender - Front	12	24	2
87-7150	Spring Cradle Assembly	17	13	2	87-9510	Decal - Load Rating	1	16	1
87-7160	Cable Clevis Assembly	14	7	3	92-0650	Bearing - Ball	34	22	1
87-7170	Bracket - Clutch Spring	30	45	1	92-0651	Case - Transaxle	32	19	1
87-7270	Washer - Flat	22	23	6	92-0652	Cover - Upper	32	7	1
87-7470	Plate - Clamp	21	16	2	92-0653	Cover - Side	32	9	1
87-7480	Washer - Flat	21	34	8	92-0654	Carrier - Differential	32	17	1
87-7480	Washer - Flat	4	37	3	92-0655	Cover - Seal	32	30	1
87-7600	Rod - Battery Support	37	21	1	92-0656	Cover - P.T.O.	32	1	1
87-7610	Tab - Battery Support	37	3	1	92-0657	Plate - Center	32	21	1
87-7620	Shield - Plastic	37	14	1	92-0662	Cap - Oil	32	5	1
87-7660	Clamp - Brake Line	9	2	8	92-0663	Shaft - Main	34	16	1
87-7660	Clamp - Tube	7	40	2	92-0664	Hub - Synchro	34	12	2
87-7710	Pulley	27	1	1	92-0665	Key - Synchro	34	23	6
87-7740	Pulley	25	17	1	92-0666	Spring - Synchro	34	13	4
87-7780	Bracket - Throttle	28	12	1	92-0667	Ring - Synchro	34	6	3
87-7790	Lever - Choke	28	2	1	92-0668	Shifter - Synchro	34	7	2
87-7800	Lever - Throttle	28	14	1	92-0672	Gear - 18T	34	19	1
87-7840	Muffler - Exhaust	29	10	1	92-0673	Gear - 14T	34	21	1
87-7850	Manifold - Exhaust	29	16	1	92-0674	Shaft - Reduction	34	28	1
87-7860	Shield - Heat	29	17	1	92-0677	Gear - 49T	34	31	1
87-7900	Engine Assembly	27	3	1	92-0679	Gear - 23T	34	25	1
87-7910	Decal - Dash	2	9	1	92-0680	Collar	34	26	1
87-7930	Decal - Danger	13	6	1	92-0681	Bearing - Needle	34	30	2

*Not Illustrated

TORO PART NUMBER INDEX (Cont.)

3322-144

Part No.	Description	Pg. No.	Ref. No.	Qty.	Part No.	Description	Pg. No.	Ref. No.	Qty.
92-0682	Washer - Thrust	34	29	1	92-0780	Bearing - Ball	36	3	1
92-0684	Gear - 33T	34	10	1	92-0781	Bearing - Needle	34	4	4
92-0687	Gear - 16T	34	18	1	92-0782	Bearing - Needle	34	33	1
92-0698	Shaft - Fork R-1	35	14	1	92-0783	Sleeve - Inner	33	5	1
92-0699	Shaft - Fork 2-3	35	7	1	92-0785	Ball	35	1	3
92-0700	Fork - Shift R-1	35	3	1	92-0787	O-Ring	36	22	1
92-0701	Fork - Shift 2-3	35	6	1	92-0788	O-Ring	32	6	1
92-0705	Lock - Spindle	35	20	1	92-0789	O-Ring	32	14	1
92-0706	Cap - Fork Shaft	32	25	1	92-0790	O-Ring	32	29	1
92-0708	Shaft - Fork Hi-Lo	35	16	1	92-0791	Seal - Oil	32	26	1
92-0709	Fork - Shift Hi-Lo	35	17	1	92-0793	Seal - Oil	32	16	2
92-0710	Counter Shaft Assembly	33	14	1	92-0793	Seal - Oil	36	32	2
92-0710	Ring Gear Assembly	36	8	1	92-0796	Screw - Cap Hex. Hd.	32	31	5
92-0711	Washer - Thrust	33	4	2	92-0803	Screw - Hex. Flange Hd.	36	30	12
92-0712	Bearing - Ball	33	1	1	92-0804	Stud	32	28	1
92-0713	Collar	33	12	1	92-0807	Cap - Sealing	32	23	1
92-0714	Bearing - Ball	33	13	2	92-0808	Shim Set	32	20	1
92-0715	Gear - 49T	33	6	1	92-0809	Shim Set	32	11	1
92-0716	Collar	33	2	1	92-0816	Arm - Shift Fork R-1	35	15	1
92-0717	Gear - 71T	33	9	1	92-0817	Arm - Shift Fork 2-3	35	5	1
92-0718	Shifter - Hi-Lo	33	7	1	92-0818	Arm - Shift Fork Hi-Lo	35	19	1
92-0719	Collar - Spline	33	8	1	92-0819	Gear - 40T	34	32	1
92-0720	Case - Differential	36	31	1	92-0820	Gear - 27T	34	5	1
92-0721	Fork - Differential Lock	36	17	1	92-0821	Gear - 24T	34	15	1
92-0722	Shaft - Lock Fork	36	18	1	92-0822	Gear - 28T	34	24	1
92-0723	Spring - Compression	36	19	1	92-0823	Gear - 43T	34	27	1
92-0724	Arm - Differential Lock	36	27	1	92-0824	Shaft - Reverse Idler	34	9	1
92-0725	Shaft - Axle L.H.	36	28	1	92-2152	Bushing - Dowel	27	6	2
92-0726	Shaft - Axle R.H.	36	1	1	92-2160	Cartridge - Relief Valve	39	12	1
92-0727	Washer	36	4	2	92-2161	Body - Relief Valve	39	28	1
92-0728	Washer	36	2	1	92-2162	Head	41	6	1
92-0729	Seal - Oil	35	10	3	92-2165	Kit - Repair	41	*	1
92-0730	Slider - Differential Lock	36	7	1	92-2173	Screw - Cap Socket Head	26	18	8
92-0731	Spring - Compression	35	2	3	92-2174	Screw - Adjusting	26	22	1
92-0732	Plate - Keeper	35	8	3	92-2175	Gear	26	11	2
92-0733	Washer	36	20	1	92-2176	Pin - Dowel	26	16	2
92-0740	Washer - Thrust	34	3	3	92-2177	Pin - Shear	26	7	1
92-0741	Washer - Thrust	33	10	1	92-2178	Ring - Crescent	26	4	4
92-0743	Breather - Air	32	27	1	92-2179	Key - Square	25	5	1
92-0744	Washer	36	14	1	92-2179	Key - Square	26	5	1
92-0745	Gear - Side L.H.	36	24	1	92-2180	Gasket - Copper	26	23	1
92-0746	Gear - Side R.H.	36	11	1	92-2181	Plate - Pressure	26	13	1
92-0747	Washer - Thrust	36	10	2	92-2182	Plate - Seal	26	9	1
92-0748	Gear - Pinion	36	12	2	92-2183	Plate - Wear	26	10	1
92-0749	Shaft - Pinion	36	23	1	92-2184	Cap - Relief Valve	26	24	1
92-0750	Washer	36	13	2	92-2185	Plug	26	19	1
92-0753	Ring - Retaining	34	2	1	92-2186	Spacer	26	3	1
92-0753	Ring - Retaining	36	21	1	92-2187	Housing - Gear, End	26	17	1
92-0754	Ring - Retaining	34	20	1	92-2189	Shaft - Drive	26	6	1
92-0755	Ring - Retaining	33	11	1	92-2190	Shaft - Idler	26	25	1
92-0756	Ring - Retaining	36	5	3	92-2191	Bearing	26	27	1
92-0759	Ring - Retaining	32	22	1	92-2192	Bearing	26	12	4
92-0760	Ring - Retaining	32	15	1	92-2193	Ball	26	20	1
92-0761	Ring - Retaining	35	18	1	92-2194	Spring	26	21	1
92-0762	Washer - Lock	32	3	1	92-2195	Seal - Oil	26	2	1
92-0763	Ring - Retaining	34	14	3	92-2196	Seal - Pressure Plate	26	15	1
92-0764	Ring - Retaining	33	3	3	92-2197	Seal - Back Up	26	14	1
92-0765	Pin - Alignment	32	8	4	92-2198	Seal	26	26	1
92-0765	Pin - Alignment	36	9	2	92-2199	Key - Ball	26	28	1
92-0768	Pin - Spring	36	15	2	92-2609	Decal - Remote Hydraulics	12	18	1
92-0769	Pin - Spring	35	4	2	92-2697	Hose - Hydraulic	40	4	1
92-0770	Pin - Spring	36	26	1	92-4101	Primary Piston Assembly	8	11	1
92-0771	Pin - Spring	36	16	1	92-4102	Secondary Piston Assembly	8	4	1
92-0772	Key	34	17	2	92-4103	Pin - Stop	8	3	1
92-0773	Drain Plug Assembly	32	13	1	92-4108	Washer - Retainer	8	10	1
92-0775	Bearing - Ball	36	6	2	92-4109	Circlip	8	9	1
92-0775	Bearing - Ball	32	33	2	92-4110	Clevis	8	5	1
92-0776	Bearing - Ball	36	29	1	92-4112	Cap Assembly	8	12	1
92-0778	Bearing - Ball	34	11	2	92-4113	Screw - Bleed	20	4	1

*Not Illustrated

TORO PART NUMBER INDEX (Cont.)

Part No.	Description	Pg. No.	Ref. No.	Qty.	Part No.	Description	Pg. No.	Ref. No.	Qty.
92-4114	Cap - Bleed Screw	20	5	1	92-4190	Yoke - End	22	29	2
92-4114	Cap - Bleed Screw	24	5	1	92-5951	Angle - Hitch	22	41	1
92-4115	Backplate Assembly LH	20	2	1	92-5972	Grommet	13	5	4
92-4116	Backplate Assembly RH	20	*	1	93-0307	Nut - Retainer	19	35	2
92-4117	Wheel Cylinder Assy. - LH	20	*	1	93-3101	Cap - Fuel	38	1	1
92-4118	Wheel Cylinder Assy. - RH	20	*	1	93-7081	Tube - Brake Front RH	9	10	1
92-4119	Kit - Seal	20	*	1	93-7082	Tube - Brake Front LH	9	16	1
92-4120	Shoe & Lining Set	20	13	1	93-7085	Tube - Brake Front	9	19	1
92-4121	Adjuster Assembly - LH	20	*	1	93-7090	Stub - Axle	22	14	2
92-4122	Adjuster Assembly - RH	20	*	1	93-7094	Cover - Wire Harness	2	36	1
92-4123	Pawl Assembly - LH	20	19	1	93-7095	Support - Engine	25	28	1
92-4123	Pawl Assembly - LH	24	19	1	93-7121	Housing - Bell	11	8	1
92-4124	Pawl Assembly - RH	20	*	1	93-7123	Hose - Brake Front	18	8	2
92-4124	Pawl Assembly - RH	24	*	1	93-7123	Hose - Brake Front	9	9	2
92-4125	Plug	20	3	1	93-7125	Brake Assembly RH	22	*	1
92-4126	Spring - Shoe, Upper LH	20	14	1	93-7125	Rear Brake Assembly - RH	24	*	1
92-4127	Spring - Shoe, Upper RH	20	*	1	93-7126	Brake Assembly LH	22	9	1
92-4128	Spring - Shoe, Lower	20	15	1	93-7126	Rear Brake Assembly - LH	24	*	1
92-4129	Spring - Adjuster, LH	20	20	1	93-7133	Arm - Control Upper LH	18	*	1
92-4130	Spring - Adjuster, RH	20	*	1	93-7135	Arm - Control Upper RH	18	21	1
92-4131	Washer - Hold Down	20	22	2	93-7145	Screw - Cap Hex. Hd.	4	19	3
92-4131	Washer - Hold Down	24	22	2	93-8943	Plate - Tail Light LH	43	12	1
92-4132	Spring - Hold Down	20	23	2	93-8961	Arm - Accelerator Pedal	7	10	1
92-4133	Pin - Hold Down	20	26	2	93-8965	Pedal - Brake	7	27	1
92-4133	Pin - Hold Down	24	26	2	93-8969	Pedal - Accelerator	7	15	1
92-4134	Plug - Inspection	20	25	1	93-8971	Seal	8	2	2
92-4134	Plug - Inspection	24	25	1	93-8990	Decal - Quick Reference	12	23	1
92-4135	Set Bolt	20	1	2	94-3800	Master Cylinder Assembly	7	3	1
92-4135	Set Bolt	24	1	2	94-3804	Rod End Assy. - LH Thread	19	*	2
92-4137	Screw - Bleed	24	4	1	94-3807	Rod End Assy. - RH Thread	19	*	2
92-4138	Backplate Assembly LH	24	2	1	94-3814	Tube - Hydraulic	7	1	1
92-4139	Backplate Assembly RH	24	*	1	94-3815	Tube - Hydraulic	7	2	1
92-4140	Wheel Cylinder Assy. - LH	24	*		94-3819	Tube - Brake Rear	9	5	1
92-4141	Wheel Cylinder Assy. - RH	24	*	1	94-3820	Tube - Brake Front	9	1	1
92-4142	Seal Kit	24	*	1	94-3821	Plate - Center, Frame	7	34	1
92-4143	Shoe & Lining Set	24	13	1	94-3829	Pin - Clevis	15	23	1
92-4144	Adjuster Assembly - LH	24	*	1	94-3834	Cable - Accelerator	28	4	1
92-4145	Adjuster Assembly - RH	24	*	1	94-3834	Cable - Accelerator	7	47	1
92-4146	Plug	24	3	1	94-3837	Cable - Clutch	2	47	1
92-4147	Spring - Shoe, Upper LH	24	14	1	94-3838	Bracket - Mudflap LH	1	23	1
92-4148	Spring - Shoe, Upper RH	24	*	1	94-3839	Bracket - Mudflap RH	1	*	1
92-4149	Spring - Shoe, Lower	24	15	1	94-3841	Mudflap	1	26	2
92-4150	Spring - Adjuster, LH	24	20	1	94-3842	Tube - Brake Rear	9	12	1
92-4151	Spring - Adjuster, RH	24	*	1	94-3843	Tube - Brake LH	21	22	1
92-4152	Spring - Hold Down	24	23	2	94-3844	Tube - Brake Line	40	29	1
92-4153	Steering Column Assembly	4	11	1	94-3845	Tube - Hydraulic	21	20	1
92-4154	Universal Joint Assembly	4	31	1	94-3846	Tube - Brake RH	21	3	1
92-4155	Upper Slip Joint Assembly	4	28	1	94-5202	Lever Support Assembly	14	14	1
92-4156	Lower Slip Joint Assembly	4	29	1	94-5203	Hydraulic Cylinder Assy.	40	17	2
92-4157	Boot - Steering Shaft	4	24	1	94-5206	Barrel Assembly	41	1	1
92-4158	Valve Assy. - Hyd. Gear	6	*	1	94-5207	Shaft	41	2	1
92-4159	Nut - Adjuster Plug Lock	5	25	1	94-5209	Dust Cover	8	7	1
92-4160	Bearing Service Kit - Upper	6	*	1	94-5210	Rod - Push	8	8	1
92-4161	Service Cover Assembly	5	*	1	94-5221	Flap - Master Cylinder	7	42	1
92-4162	Pitman Shaft - Gear Service	6	*	1	94-5223	Bell Crank	7	19	1
92-4163	Steering Housing Assembly	6	*	1	94-5240	Operators Platform Assy.	1	17	1
92-4164	Plug Assy. - Service Adjust.	6	*	1	94-5245	Supervisor Switch Assy.	2	26	1
92-4165	Plug - Housing End	5	2	1	94-5261	Tire	19	5	2
92-4166	Rack/Piston/Nut Assembly	6	*	1	94-5272	Decal - Warning	2	48	1
92-4167	Service Plug Assembly	6	*	1	94-5299	Rod - Link	7	25	1
92-4168	Return - Guide Ball	5	7	2	95-7394	Shaft - Brake	7	35	1
92-4169	Bearing - Needle	5	21	1	98-2558	Cover - Clutch	27	15	1
92-4170	Bearing - Pitman Shaft	5	47	1	98-2559	Disk - Clutch	27	16	1
92-4179	Yoke, Shaft & Seal Tube	22	33	2	98-2918	Driveshaft Assembly	23	*51	2
92-4180	Seal	22	32	2	98-2919	Fuel Tank Assembly	38	2	1
92-4182	Yoke & Hub	22	31	2	98-2939	Screw - Cap Hex. Hd.	22	37	4
92-4187	Cross & Bearing Kit	22	30	4	98-2940	Yoke - Double Clamp	22	34	2
92-4188	Ring - Snap	22	28	16	98-2962	Seal Kit - Pitman Shaft	6	*	1
92-4189	Strap & Bolt Kit	22	36	2	98-2967	Driveshaft Assembly Kit	23	*	2

*Not Illustrated

TORO PART NUMBER INDEX (Cont.)

3322-144

Part No.	Description	Pg. No.	Ref. No.	Qty.	Part No.	Description	Pg. No.	Ref. No.	Qty.
98-2968	Yoke Kit	23	*	2	283-75	Pin - Clevis	11	33	1
98-2969	1/2 Yoke Kit	23	*	2	283-85	Pin - Clevis	7	14	1
99-1115	Harness - Wire Rear	2	38	1	302-5	Fitting - Grease	7	8	3
99-1199	Pedal - Clutch	11	37	1	302-5	Fitting - Grease	18	14	4
99-1201	Clutch Cable Assembly	11	31	1	302-5	Fitting - Grease	19	20	4
99-1202	Rod End	11	46	1	302-5	Fitting - Grease	4	30	1
218-446	Nut - Hex.	2	12	1	302-5	Fitting - Grease	22	35	2
218-447	Washer - Lock	2	13	1	302-5	Fitting - Grease	11	44	1
218-574	Fuse 7.5 Amp.	2	42	2	302-11	Fitting - Grease	17	8	2
218-578	Fuse 10 Amp.	2	43	1	302-58	Fitting - Grease	22	46	16
218-600	Bulb	2	21	1	321-2	Screw - Cap Hex. Hd.	2	1	7
232-27	Stem - Valve	19	31	2	321-3	Screw - Cap Hex. Hd.	2	4	2
232-27	Valve - Stem	22	17	2	321-3	Screw - Cap Hex. Hd.	4	33	2
233-37	Knob	14	1	1	321-4	Screw - Cap Hex. Hd.	29	1	2
233-39	Knob	39	1	1	321-4	Screw - Cap Hex. Hd.	37	8	1
233-39	Knob	4	1	1	321-4	Screw - Cap Hex. Hd.	12	9	8
233-48	Knob	15	4	1	321-4	Screw - Cap Hex. Hd.	9	13	1
237-21	Seal - O-Ring	40	2	6	321-4	Screw - Cap Hex. Hd.	13	20	8
237-22	Seal - O-Ring	40	6	2	321-4	Screw - Cap Hex. Hd.	1	24	4
237-22	Seal - O-Ring	39	9	4	321-4	Screw - Cap Hex. Hd.	11	29	1
237-22	Seal - O-Ring	25	10	1	321-4	Screw - Cap Hex. Hd.	2	32	1
237-30	O-Ring	30	34	2	321-6	Screw - Cap Hex. Hd.	43	2	2
237-42	O-Ring	42	2	2	321-6	Screw - Cap Hex. Hd.	18	5	2
237-42	Seal - O-Ring	40	8	2	321-9	Screw - Cap Hex. Hd.	9	3	4
237-42	Seal - O-Ring	39	11	2	321-9	Screw - Cap Hex. Hd.	39	5	2
237-42	Seal - O-Ring	30	47	1	321-9	Screw - Cap Hex. Hd.	15	27	1
237-78	Seal - O-Ring	40	15	4	321-9	Screw - Cap Hex. Hd.	7	38	1
237-79	Seal - O-Ring	25	8	1	321-14	Screw - Cap Hex. Hd.	40	9	2
237-79	Seal - O-Ring	30	39	2	321-15	Screw - Cap Hex. Hd.	39	13	1
237-80	Seal - O-Ring	25	12	1	322-2	Screw - Cap Hex. Hd.	9	11	1
237-81	Seal - O-Ring	30	28	1	322-2	Screw - Cap Hex. Hd.	4	16	6
237-123	Seal - O-Ring	30	25	1	322-2	Screw - Cap Hex. Hd.	2	37	3
240-5	Grommet	11	30	1	322-3	Screw - Cap Hex. Hd.	40	21	4
241-119	Cap Dust	19	1	2	322-4	Screw - Cap Hex. Hd.	29	13	2
2410-35	Plug - Hole	2	6	1	322-5	Screw - Cap Hex. Hd.	12	6	8
2410-42	Cap - Front Bumper	1	12	2	322-5	Screw - Cap Hex. Hd.	18	10	2
2411-33	Joint - Ball	11	3	1	322-5	Screw - Cap Hex. Hd.	43	14	2
2412-10	Clamp - R	18	7	2	322-5	Screw - Cap Hex. Hd.	25	16	1
2412-34	Clamp - Hose	25	3	1	322-5	Screw - Cap Hex. Hd.	39	24	1
2412-34	Clamp - Hose	31	53	1	322-5	Screw - Cap Hex. Hd.	7	36	1
2412-36	Clamp	38	8	1	322-12	Screw - Cap Hex. Hd.	14	25	1
2412-36	Clamp - Hose	30	3	3	323-4	Screw - Cap Hex. Hd.	38	13	2
2412-89	Clamp - R	25	1	2	323-4	Screw - Cap Hex. Hd.	1	22	1
2412-89	Clamp - R	37	5	1	323-6	Screw - Cap Hex. Hd.	15	1	1
2412-89	Clamp - R	9	21	1	323-6	Screw - Cap Hex. Hd.	22	11	8
2412-89	Clamp - R	11	28	1	323-6	Screw - Cap Hex. Hd.	13	12	2
2412-89	Clamp - R	2	31	1	323-6	Screw - Cap Hex. Hd.	38	22	1
2412-93	Clamp - R	43	1	1	323-6	Screw - Cap Hex. Hd.	14	37	1
2412-96	Clamp - R	38	23	1	323-7	Screw - Cap Hex. Hd.	30	14	4
2412-105	Clamp - R	4	17	2	323-7	Screw - Cap Hex. Hd.	7	17	2
2412-108	Clamp - Hose	38	10	4	323-7	Screw - Cap Hex. Hd.	22	43	4
2412-133	R-Clamp	13	3	2	323-8	Screw - Hex. Flange Hd.	19	11	8
2412-149	Clamp - R	40	28	1	323-9	Screw - Cap Hex. Hd.	37	16	1
2412-149	Clamp - Tube	21	24	4	323-9	Screw - Cap Hex. Hd.	27	27	4
251-8	Bearing - Ball	34	1	2	323-10	Screw - Cap Hex. Hd.	30	8	1
251-346	Bearing - Ball	34	8	1	323-12	Screw - Cap Hex. Hd.	17	6	8
254-72	Cup - Bearing	19	29	2	324-4	Screw - Cap Hex. Hd.	27	19	4
254-94	Cone - Bearing	19	30	2	324-9	Screw - Cap Hex. Hd.	17	22	4
254-106	Cone - Bearing	19	27	2	324-10	Screw - Cap Hex. Hd.	17	1	4
254-107	Cup - Bearing	19	28	2	324-12	Screw - Cap Hex. Hd.	25	35	2
256-155	Bushing - Flange	7	26	2	324-13	Screw - Cap Hex. Hd.	17	10	2
256-156	Bushing - Flange	11	36	2	325-4	Screw - Cap Hex. Hd.	13	15	2
256-247	Bushing - Flange	7	18	2	325-13	Screw - Cap Hex. Hd.	18	11	8
256-259	Bushing - Flange	7	9	2	325-13	Screw - Cap Hex. Hd.	17	27	4
283-2	Pin - Clevis	7	4	1	325-19	Screw - Cap Hex. Hd.	22	27	1
283-30	Pin - Clevis	7	12	1	325-20	Screw - Cap Hex. Hd.	22	24	5
283-62	Pin - Clevis	15	6	1	329-6	Screw - Cap Hex. Hd.	28	9	1
283-62	Pin - Clevis	14	8	3	329-7	Screw - Cap Hex. Hd.	28	11	1
283-62	Pin - Clevis	30	35	3	3211-8	Screw - Cap Hex. Hd.	14	13	2

*Not Illustrated

TORO PART NUMBER INDEX (Cont.)

Part No.	Description	Pg. No.	Ref. No.	Qty.	Part No.	Description	Pg. No.	Ref. No.	Qty.
3215-1	Screw - Cap Hex. Hd.	30	16	2	3256-23	Washer - Flat	39	26	2
3217-25	Nut - Hex	2	24	2	3256-24	Washer - Flat	37	17	2
3217-29	Nut - Hex.	2	27	3	3256-24	Washer - Flat	27	26	4
3218-18	Nut - Jam	14	43	1	3256-25	Washer - Flat	27	21	4
3218-20	Nut - Jam	11	17	2	3256-25	Washer - Flat	25	34	2
3218-21	Nut - Jam	19	18	2	3256-26	Washer - Flat	7	21	1
3219-14	Nut	14	5	1	3256-27	Washer - Flat	21	6	8
3219-14	Nut - Hex.	30	32	1	3256-27	Washer - Flat	17	31	2
3220-1	Nut - Jam	28	10	2	3256-28	Washer - Flat	19	3	2
3220-1	Nut - Jam	30	37	4	3256-28	Washer - Flat	27	30	1
3220-1	Nut - Jam	14	41	4	3256-45	Washer - Flat	25	18	1
3220-2	Nut - Jam	11	2	1	3256-61	Washer - Flat	12	25	14
3220-3	Nut - Hex. Jam	7	24	1	3256-61	Washer - Flat	1	29	4
3220-3	Nut - Jam	14	12	2	3257-5	Key - Woodruff	27	9	1
3220-3	Nut - Jam	12	28	1	3257-7	Key - Woodruff	27	2	1
3220-11	Nut - Jam	19	23	2	3269-27	Rivet - Plastic	37	13	4
3220-16	Nut - Hex. Jam	7	44	1	3272-6	Pin - Cotter	14	3	3
3229-1	Screw - Carriage	40	19	2	3272-6	Pin - Cotter	7	7	1
3230-2	Bolt - Carriage	29	4	5	3272-6	Pin - Cotter	15	8	2
3230-18	Bolt - Carriage	13	2	2	3272-6	Pin - Cotter	30	30	3
3230-22	Bolt - Carriage	25	30	1	3272-10	Pin - Cotter	7	11	2
3230-23	Bolt - Carriage	37	6	4	3272-10	Pin - Cotter	11	32	1
3231-21	Bolt - Carriage	37	7	6	3272-12	Pin - Cotter	18	17	4
3231-21	Bolt - Carriage	39	21	2	3272-12	Pin - Cotter	19	21	4
3231-21	Bolt - Carriage	13	22	4	3272-12	Pin - Cotter	19	32	2
3231-21	Bolt - Carriage	14	32	4	3272-37	Pin - Cotter	40	20	2
3231-25	Bolt - Carriage	17	21	4	3274-1	Screw - Hex. Socket Hd.	27	11	1
3232-17	Bolt - Carriage	21	19	8	3274-15	Screw - Hex. Socket Hd.	28	16	1
3234-1	Screw - Hex. Flange Hd.	1	13	6	3274-31	Screw - Hex. Socket Hd.	2	8	4
3234-4	Screw - Cap Hex. Hd.	21	26	3	3274-54	Screw - Hex. Socket Hd.	38	16	2
3234-4	Screw - Hex. Flange Hd.	30	42	4	3277-1	Nut - Hex.	4	5	1
3234-11	Screw - Cap Hex. Hd.	25	25	6	3290-221	Washer - Spring	14	34	1
3234-38	Screw - Cap Hex. Hd.	38	19	2	3290-221	Washer - Spring	15	36	2
3234-38	Screw - Hex. Flange Hd.	21	17	24	3290-321	Screw - Hex. Flange Hd.	7	31	2
3234-40	Screw - Hex. Flange Hd.	16	4	4	3290-357	Nut - Flange	38	20	3
3250-13	Screw	2	44	2	3290-357	Nut - Flange	7	37	2
3250-13	Screw - Hex. Hd.	12	15	20	3290-357	Nut - Flange Lock	37	1	6
3250-13	Screw - Pan Hd.	1	27	4	3290-357	Nut - Flange Lock	1	8	9
3253-4	Washer - Lock	12	5	8	3290-357	Nut - Flange Lock	13	10	4
3253-4	Washer - Lock	27	14	6	3290-357	Nut - Flange Lock	17	16	4
3253-4	Washer - Lock	4	14	4	3290-357	Nut - Flange Lock	14	33	4
3253-6	Washer - Lock	27	20	4	3290-413	Washer - Belleville	25	23	12
3253-6	Washer - Lock	22	45	10	3290-455	Washer	4	12	1
3253-15	Washer - Lock	38	5	5	3290-456	Washer - Belleville	14	46	2
3253-15	Washer - Lock	2	23	2	3290-477	Washer - Curved	15	28	1
3253-19	Washer - Lock	2	28	3	3290-478	Washer - Belleville	15	17	1
3253-21	Washer - Lock	22	10	8	3290-506	Palnut	43	3	2
3253-21	Washer - Lock	13	13	2	3290-507	Pin - Dowel	14	31	1
3253-21	Washer - Lock	19	33	8	3296-2	Nut - Lock	12	22	20
3253-22	Washer - Lock	27	7	4	3296-2	Nut - Lock	1	30	4
3253-22	Washer - Lock	11	12	4	3296-2	Nut - Lock	7	33	2
3255-8	Washer - Lock ETLW	25	13	1	3296-2	Nut - Lock	2	39	2
3255-9	Washer - Lock	27	28	1	3296-3	Nut - Lock	28	13	1
3255-9	Washer - Lock ETLW	37	2	1	3296-4	Nut - Lock	11	4	1
3256-4	Washer - Flat	30	12	1	3296-5	Nut - Lock	25	19	1
3256-6	Washer - Flat	21	9	4	3296-6	Nut - Lock	7	20	2
3256-6	Washer - Flat	17	32	2	3296-15	Nut - Lock	27	31	1
3256-14	Washer - Flat	39	30	1	3296-23	Nut - Flange Lock	18	12	8
3256-22	Washer - Flat	9	4	4	3296-23	Nut - Lock	21	10	4
3256-22	Washer - Flat	2	5	2	3296-23	Nut - Lock	17	14	4
3256-22	Washer - Flat	12	8	8	3296-23	Nut - Lock	13	16	2
3256-22	Washer - Flat	43	11	2	3296-23	Nut - Lock	7	22	1
3256-22	Washer - Flat	39	18	3	3296-29	Nut - Lock	25	7	2
3256-22	Washer - Flat	13	19	8	3296-29	Nut - Lock	28	7	1
3256-22	Washer - Flat	11	39	2	3296-29	Nut - Lock	11	16	1
3256-22	Washer - Flat	7	39	3	3296-29	Nut - Lock	43	16	2
3256-23	Washer - Flat	12	4	4	3296-29	Nut - Lock	39	27	1
3256-23	Washer - Flat	43	15	2	3296-29	Nut - Lock	7	30	1
3256-23	Washer - Flat	15	21	1	3296-39	Nut - Flange Lock	30	20	4

*Not Illustrated

TORO PART NUMBER INDEX (Cont.)

3322-144

Part No.	Description	Pg. No.	Ref. No.	Qty.	Part No.	Description	Pg. No.	Ref. No.	Qty.
3296-39	Nut - Flange Lock	37	20	1	32128-33	Nut - Flange Lock	39	6	1
3296-39	Nut - Lock	21	13	6	32128-33	Nut - Flange Lock	28	8	1
3296-39	Nut - Lock	19	16	8	32128-33	Nut - Flange Lock	11	27	1
3296-39	Nut - Lock	25	22	6	32128-33	Nut - Flange Lock	21	27	4
3296-39	Nut - Lock	39	23	2	32128-33	Nut - Lock	1	25	4
3296-39	Nut - Lock	27	25	4	32128-36	Nut - Lock	22	38	4
3296-39	Nut - Lock	17	28	8	32128-44	Nut - Flange Lock	13	9	2
3296-39	Nut - Lock	15	33	1	32128-53	Nut - Flange Lock	22	26	2
3296-39	Nut - Lock	22	42	4	32136-2	Nut - Slotted	18	2	4
3296-39	Nut - Lock	14	45	1	32136-3	Nut - Slotted	19	22	4
3296-42	Nut - Lock	15	12	2	32136-5	Nut Slotted	19	2	2
3296-42	Nut - Lock	18	13	2	32144-4	Screw - HH	28	17	2
3296-42	Nut - Lock	43	13	2	32144-4	Screw - Hex. Washer Hd.	14	9	2
3296-42	Nut - Lock	38	14	2	32144-10	Screw - Self Tapping	4	18	2
3296-42	Nut - Lock	39	19	2	32144-10	Screw - Self Tapping	25	33	2
3296-42	Nut - Lock	9	20	5	32144-14	Screw - Self Tapping	25	15	1
3296-42	Nut - Lock	4	32	2	32144-18	Screw - Cap Hex. Hd.	2	17	2
3296-42	Nut - Lock	7	41	1	32144-52	Screw - Hex. Hd.	12	12	6
3296-48	Nut - Lock	17	11	10	32144-93	Screw - Self Tapping	43	6	2
3296-48	Nut - Lock	25	27	2	32144-116	Screw - Pan Head	4	8	8
3296-58	Nut - Lock	14	11	2	32148-6	Insert - Threaded	2	2	2
3296-59	Nut - Lock	4	13	1	32148-7	Nut - Clinch	1	18	8
3296-76	Nut - Lock	21	33	8	32148-7	Nut - Clinch	14	19	2
32104-88	Screw	1	4	6	32148-9	Insert - Threaded	21	1	8
32120-47	Ring - E	7	13	1	32148-15	Insert - Threaded	14	4	1
32120-47	Ring - E	11	35	2	32148-15	Nut - Clinch	30	31	1
32120-47	Ring - Retaining	15	10	3	32151-41	Ring - Retaining	26	1	1
32121-7	Pin - Roll	11	22	1	32151-56	Ring - Retaining	7	16	1
32121-24	Pin - Roll	11	24	2	32151-104	Ring - Snap	18	15	4
32121-48	Pin - Roll	14	23	1	32152-10	Nut	41	12	1
32122-24	Screw - Round Hd.	38	6	5	33114-016	Screw - Cap Hex. Hd.	27	13	6
32128-20	Nut - Flange	9	17	1	33114-020	Screw - Cap Hex. Hd.	11	1	4
32128-20	Nut - Flange	4	27	6	33114-020	Screw - Cap Hex. Hd.	29	9	1
32128-20	Nut - Flange	2	35	3	33114-020	Screw - Cap Hex. Hd.	30	24	5
32128-20	Nut - Flange Head	40	12	4	33114-025	Screw - Cap Hex. Hd.	11	42	3
32128-20	Nut - Flange Lock	18	6	2	33114-025	Screw - Cap Hex. Hd.	29	15	2
32128-20	Nut - Flange Lock	29	7	5	33114-030	Screw - Cap Hex. Hd.	29	6	2
32128-20	Nut - Flange Lock	37	18	2	33114-040	Screw - Cap Hex. Hd.	11	21	9
32128-20	Nut - Flange Lock	13	21	8	340-2	Fitting - Straight	40	11	1
32128-20	Nut - Flange Lock	7	29	2	340-3	Fitting - Hydraulic Straight	25	9	1
32128-21	Nut - Lock	30	11	1	340-77	Fitting - Hydraulic 90°	40	7	1
32128-23	Nut - Flange	38	21	2	340-86	Fitting - Hydraulic Tee	39	15	1
32128-23	Nut - Flange Lock	16	5	4	340-92	Fitting - Hydraulic Straight	40	26	1
32128-23	Nut - Flange Lock	21	21	24	340-94	Fitting - Hydraulic Tee	39	10	1
32128-25	Nut - Lock	29	11	2	340-132	Fitting - Hydraulic 90°	40	14	4
32128-33	Nut - Flange	2	34	12	340-140	Fitting - Hydraulic Tee	40	24	1
32128-33	Nut - Flange Head	40	13	4	340-151	Fitting - Hydraulic Tee	40	27	1
32128-33	Nut - Flange Lock	30	1	1	353-987	Fitting - Hydraulic 90°	30	29	1
32128-33	Nut - Flange Lock	29	3	2	354-134	Fitting - Hydraulic 90°	30	40	2
32128-33	Nut - Flange Lock	37	4	1	354-135	Fitting - Hydraulic 90°	30	5	1

*Not Illustrated

PRODUCT CHANGES

In an effort to make improvements available to TORO owners as quickly as possible, minor changes are incorporated into Toro's products from time to time that do not become immediately shown in the Parts Catalog. If such a change has been made in your unit, which is not reflected in your manual, see your TORO Distributor or his Authorized TORO Service Dealer for information and part numbers.

IDENTIFICATION AND ORDERING

MODEL AND SERIAL NUMBERS

The Workman 3100 has two identification numbers; a model number and a serial number. The two numbers are stamped on a plate which is located on the main frame. In any correspondence concerning the Workman 3100, supply model and serial numbers to assure that correct information and replacement parts are obtained.

To order replacement parts from an Authorized TORO Service Dealer, supply the following information:

1. Model and serial number of the Workman 3100.
2. Part number, description, and the quantity of part(s) desired.

NOTE: Do not order by reference number if a parts catalog is being used; use the PART NUMBER.

TABLE OF CONTENTS

Description	Page	Description	Page
Front Bumper & Hood Assembly	1	Engine Frame & Hydraulic Pump Assembly	25
Control Panel Assembly	2	Hydraulic Pump Assembly No. 87-5700	26
Electrical Schematic	3	Engine Installation Assembly	27
Steering Linkage Assembly	4	Throttle Linkage Assembly	28
Steering Gear Assembly No. 87-1500	5-6	Muffler & Relay Assembly	29
Brake & Accelerator Pedal Assembly	7	Transaxle Installation Assembly	30-31
Master Brake Cylinder No. 94-3800	8	Transaxle Case Assembly	32
Hydraulic Brake Line Routing Assembly	9	Countershaft Assembly	33
Hydraulic Schematic	10	Transaxle Gear Shafts Assembly	34
Clutch Linkage Assembly	11	Shift Fork Assembly	35
Seat Base Assembly	12	Differential Gear Assembly	36
Seat Back Assembly	13	Battery Mount Assembly	37
Hi-Lo Shift Levers Assemblies	14	Fuel Tank Assembly	38
Differential Lock & Parking Brake Assemblies	15	Lift Valve Linkage Assembly	39
R.O.P.S. Assembly	16	Lift Valve & Cylinder Assembly	40
Front Suspension Assembly	17	Lift Cylinder No. 94-5203	41
Front Suspension Control Arm Assembly	18	Control Valve Assembly No. 43-1950	42
Front Wheel Assembly	19	Tail Light Assembly	43
Front Brake Assembly	20	Engine	
Rear Frame Assembly	21	Kohler Model CH22S Spec. No. 66513	44-51
Rear Axle Assembly	22-23	TORO Part Number Index	52-59
Rear Brake Assembly	24		