



ProLine

Mid Size Traction Unit

15 H.P. Kohler Gear Drive

Model No. 30177 – 990001 & Up

Parts Catalog

ORDERING REPLACEMENT PARTS

To order replacement parts, please supply: the part number, the quantity, and the description of each part desired.

Contents

Description	Page	Description	Page
Fuel Tank & Idler Bracket Assembly	1	Cylinder Head, Valves And Breather	11
Transmission & Idler Pulley Assembly	2	Ignition / Electrical	12
Brake, Wheel Pulley & Wheel Assembly	3	Blower Housing And Baffles	13
Wheel And Tire Asm	4	Starter System	14
Handle & Control Panel Assembly	5	Fuel System	15
Engine Assembly	6	Engine Controls	16
Clutch Asm No. 54-3200	7	Air Cleaner	17
Peerless Transmission Model 700-082	8	Exhaust	18
Crankcase	9	Note:	
Oil Pan / Lubrication	10		

Part Description Abbreviations

Part descriptions in this catalog may include the following abbreviations.

Abbreviation	Meaning	Abbreviation	Meaning
AR	as required	HWHTF	hex washer head thread forming
ASM	assembly	INC	incorporated
CARR	carriage	LH	left hand
DEG	degrees	PH	pan head
FH	flat head	PPH	Phillips pan head
GA	gauge	PTO	power take off
HF	hex flange	RH	right hand
HFW	hex flange washer	SFH	slotted fillister head
HH	hex head	SH	square head
HHF	hex head flange	SHWH	slotted hex washer head
HHST	hex head self tapping	SPH	slotted pan head
HJ	hex jam	STD	standard
HOC	height-of-cut	TAP	self tapping
HS	hex socket	TH	truss head
HSBH	hex socket button head	TTH	Torx truss head
HSFH	hex socket flat head	WH	wing head
HSH	hex socket head		
HWH	hex washer head		

Important Format Explanations

This catalog uses special formats to convey information in illustrations and parts lists. Specifically, one format is used in conjunction with service assemblies and another with quantities associated with reference numbers.

Service Assemblies

Parts within service assemblies have reference numbers in the form X:Y. X is the reference number of the service assembly and Y is a sequential number unique to each part within the service assembly.

For example, a wheel assembly might be identified by reference number 6, the tire by 6:1, the valve by 6:2, and the wheel by 6:3. When you order the assembly identified by reference number 6, you receive all parts identified by reference numbers 6:1, 6:2, and 6:3. However, you may also order any part individually.

Reference numbers of this type appear in part lists and as callouts in illustrations.

Reference Numbers with Quantities

Illustrations may have a quantity in parentheses next to a reference number, in the form $X (Y)$. X is the reference number. Y in parentheses is the quantity of the part identified by the reference number.

For example, the illustration callout 4 (2) indicates that two parts are used in that instance.

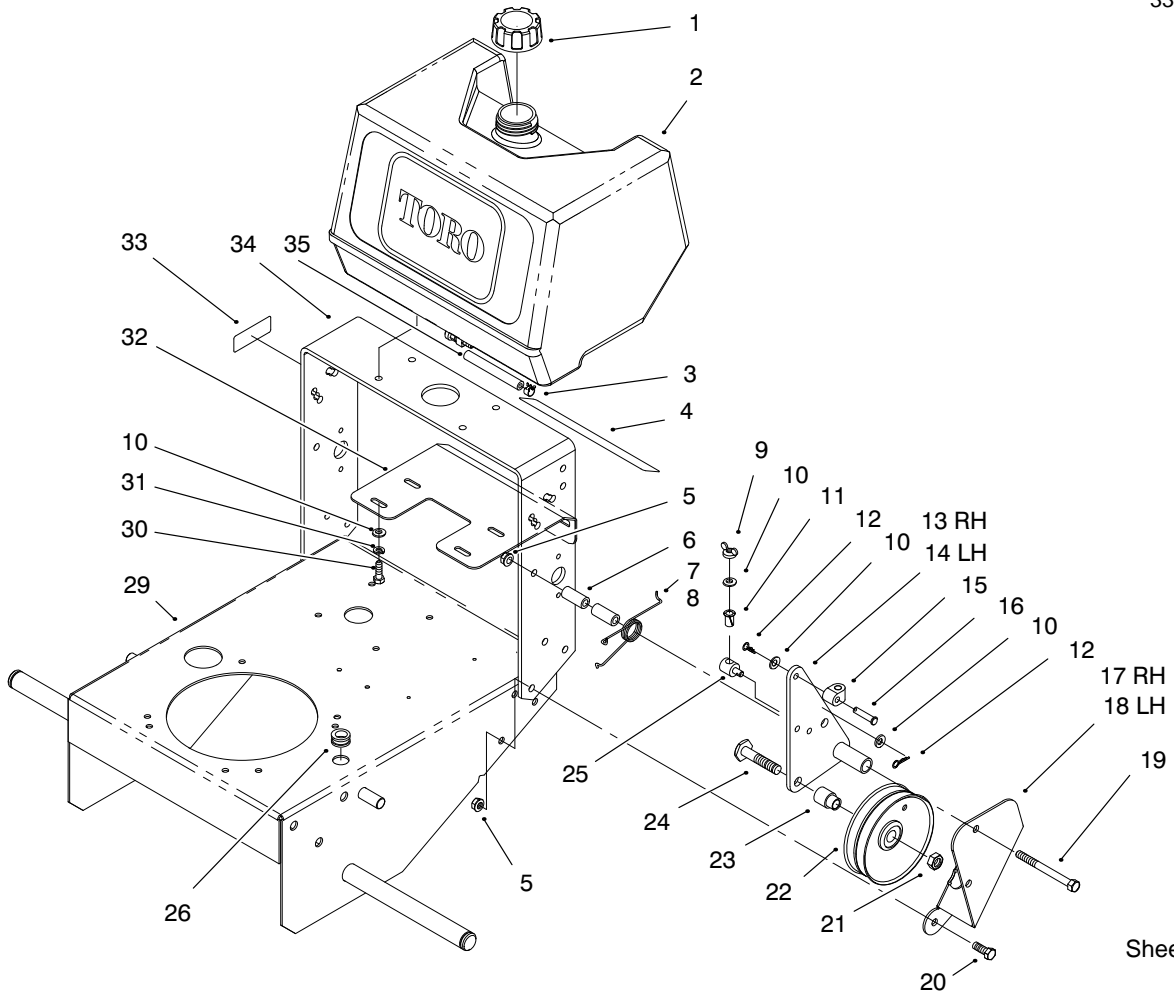

Sheet No.: 2

Fuel Tank & Idler Bracket Assembly

Ref. No.	Part No.	Qty.	Description
1	55-3570	1	Cap-Fuel
2	95-2802	1	Tank-Fuel
3	2412-98	2	Clamp-Hose
4	82-7750	1	Decal-Ground Speed
5	3296-39	8	Nut-Lock
6	74-0040	4	Spacer-Pivot
7	51-4370	1	Spring-RH
8	51-4380	1	Spring-LH
9	32103-25	2	Nut-Wing
10	3256-23	10	Washer-Flat
11	52-2890	2	Bushing-Flanged
12	3290-307	4	Pin-Cotter
13	74-0230	1	Idler Bracket RH
14	74-0220	1	Idler Bracket LH
15	74-0521	2	Rod-Fitting
16	283-6	2	Pin-Clevis
17	67-6370	1	Bracket-RH
18	67-6380	1	Bracket-LH
19	323-16	2	Screw-HH
20	323-6	6	Screw-HH
21	3296-23	2	Nut-Lock
22	95-2800	2	Pulley-Idler
23	95-2801	2	Spacer-Pulley
24	51-4450	2	Screw-Leveler
25	68-9690	2	Fitting Rod
26	237-124	1	Grommet

Ref. No.	Part No.	Qty.	Description
29	93-1156	1	Frame
30	322-4	4	Screw-HH
31	3253-4	4	Washer-Lock
32	66-7400	1	Plate-Control
33	95-2814	1	Decal-Fuel Shut-Off
34	74-0360	1	Frame-Rear
35	47-2964	1	Hose-Gas

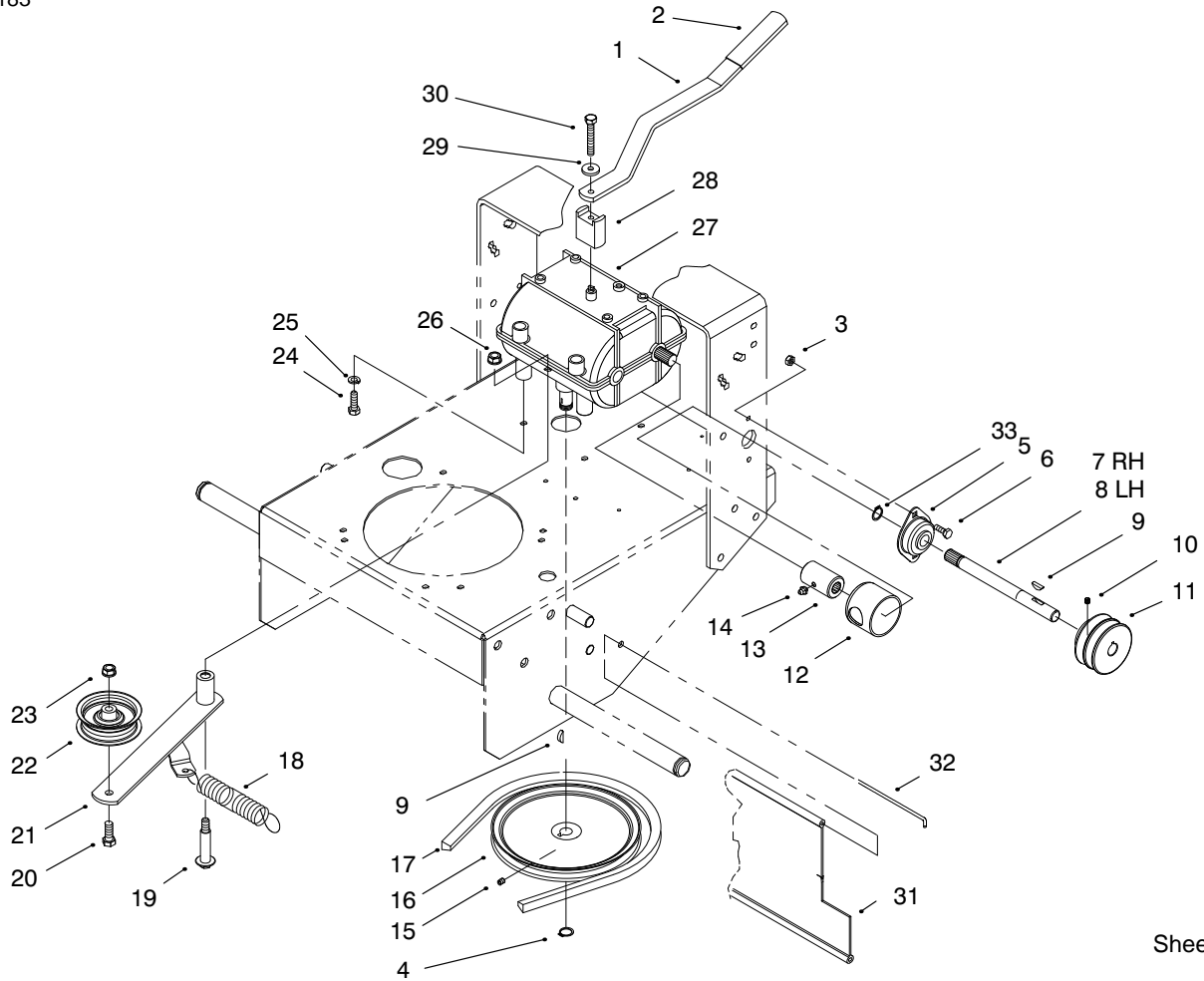

Sheet No.: 3

Transmission & Idler Pulley Assembly

Ref. No.	Part No.	Qty.	Description
1	74-0320	1	Lever-Shift
2	47-1970	1	Grip-Engagement
3	3296-42	4	Nut-Lock
4	32120-64	1	Ring-Retaining
5	51-4270	2	Bearing-Shaft Ext
6	321-4	4	Screw-HH
7	98-0788	1	Shaft-RH
8	98-0787	1	Shaft-LH
9	3257-5	3	Key-Woodruff
10	3245-3	2	Screw-HSH
11	74-0480	2	Pulley-Drive ASM
12	51-4220	2	Guard-Coupler
13	98-0789	2	Coupler
14	302-5	2	Fitting-Grease
15	3245-1	1	Screw-Set
16	51-4190	1	Pulley-Drive
17	26-9671	1	"v" Belt
18	68-2190	1	Spring-Extension
19	27-6230	1	Bolt-Wheel
20	323-8	1	Screw-HH
21	82-4800	1	Lever-Idler
22	62-4540-03	1	Pulley-Idler
23	3296-39	1	Nut-Lock
24	322-2	4	Screw-HH
25	3253-4	4	Washer-Lock
26	3296-6	1	Nut-Lock

Ref. No.	Part No.	Qty.	Description
27		1	Transmission-4 Speed
28	72-2190	1	Mount-Shift Lever
29	7-5461	1	Spacer-Transmission
30	329-10	1	Screw
31	95-1526	1	Shield-Trailing
32	95-1529	1	Rod-Shield
33	32151-62	2	Ring-Retaining

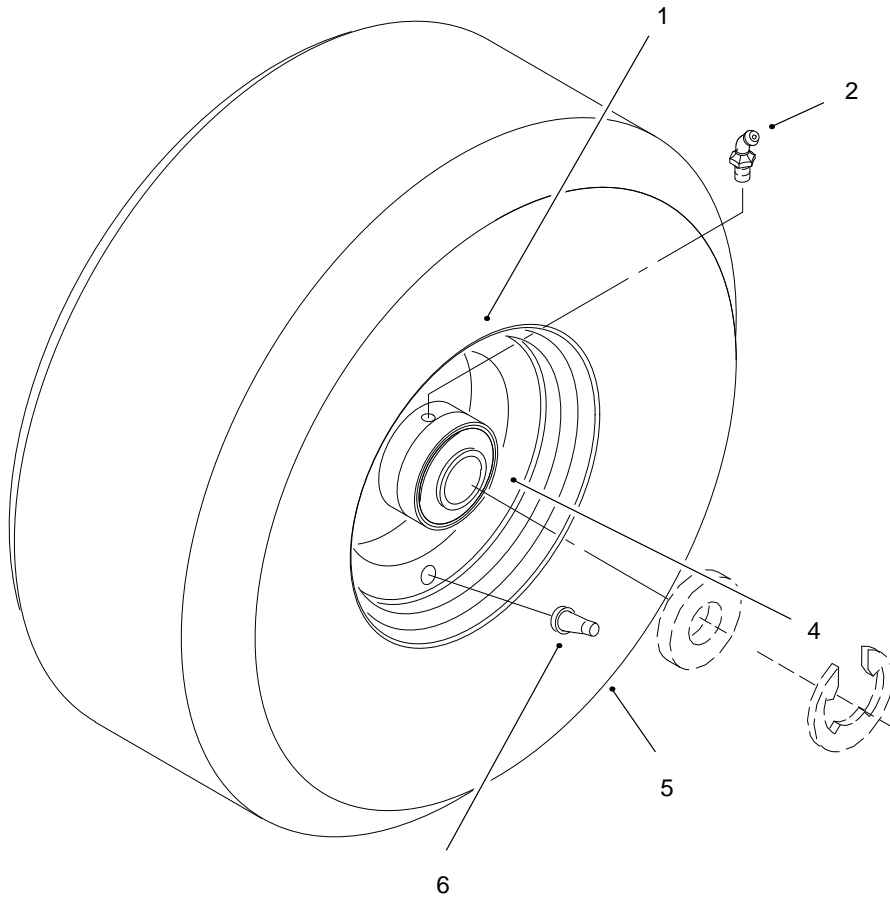

Sheet No.: 500

Wheel And Tire Asm

Ref. No.	Part No.	Qty.	Description
1	242-80	2	Rim
2	302-11	2	Fitting-Grease
4	92-1746	4	Bearing
5	231-117	2	Tire-15x6
6	232-27	2	Valve Stem

Ref. No.	Part No.	Qty.	Description

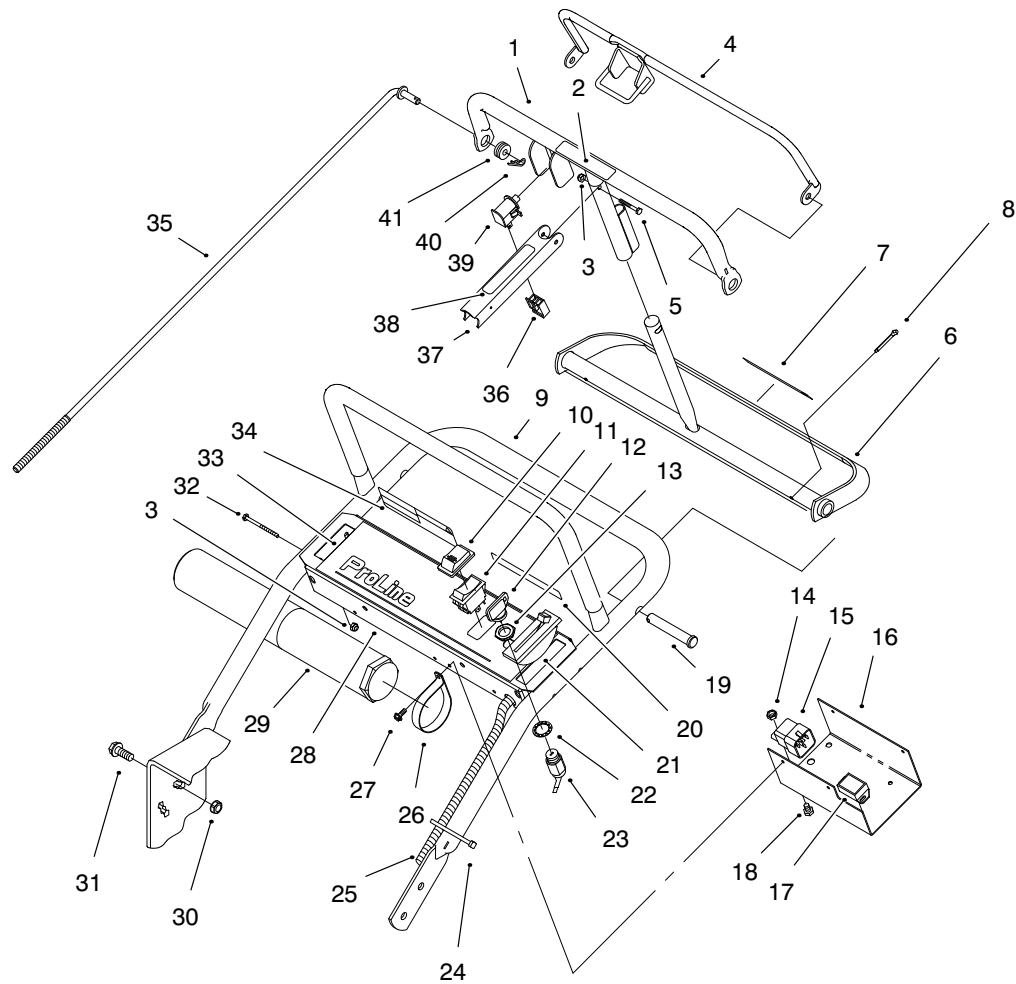

Sheet No.: 5

Handle & Control Panel Assembly

Ref. No.	Part No.	Qty.	Description
1	82-7690	1	Bar
2	82-2290	1	Decal-Control Bar
3	3296-2	5	Nut-Lock
4	82-7680-03	1	Bail
5	32105-1	1	Screw-HH
6	99-8501	1	Control Pivot
7	82-2280	1	Decal-Reverse
8	3272-11	2	Pin-Cotter
9	67-6440	1	Handle-Upper
10	82-3820	1	Boot-Switch
11	82-2300	1	Switch
12	63-8360	2	Key-Ignition
13	218-461	1	Nut-HH (F/W Sw)
14	3296-42	1	Nut-Lock
15	63-7590	1	Relay
16	93-1187-03	1	Panel-Bottom
17	94-9666	1	Module
18	321-2	1	Screw-HH
19	283-55	2	Pin-Clevis
20	65-3090	1	Decal-Manual
21	74-0630	1	Control-Throttle
22	3254-5	1	Washer-Lock
23	29-5560	1	Switch-On/Off
24	3290-378	2	Tie-Cable
25	95-2803	1	Wire Harness
26	2412-120	2	Clamp-R

Ref. No.	Part No.	Qty.	Description
27	32104-76	4	Screw-Self TAP
28	82-2180-03	1	Panel-Control
29	74-0720	1	Tube-Manual
30	32128-21	4	Nut-HF
31	3234-11	4	Screw-HHF
32	32105-14	4	Screw-HH
33	82-7730	1	Decal-Panel Proline
34	71-1280	1	Decal-Warning
35	82-7631	2	Rod-Control
36	218-595	1	Connector-Body
37	51-4850	1	Lever-Parking Brake
38	52-2010	1	Decal-Parking Lever
39	82-2190	1	Switch-Bail
40	3290-307	2	Pin-Cotter
41	237-141	2	Grommet

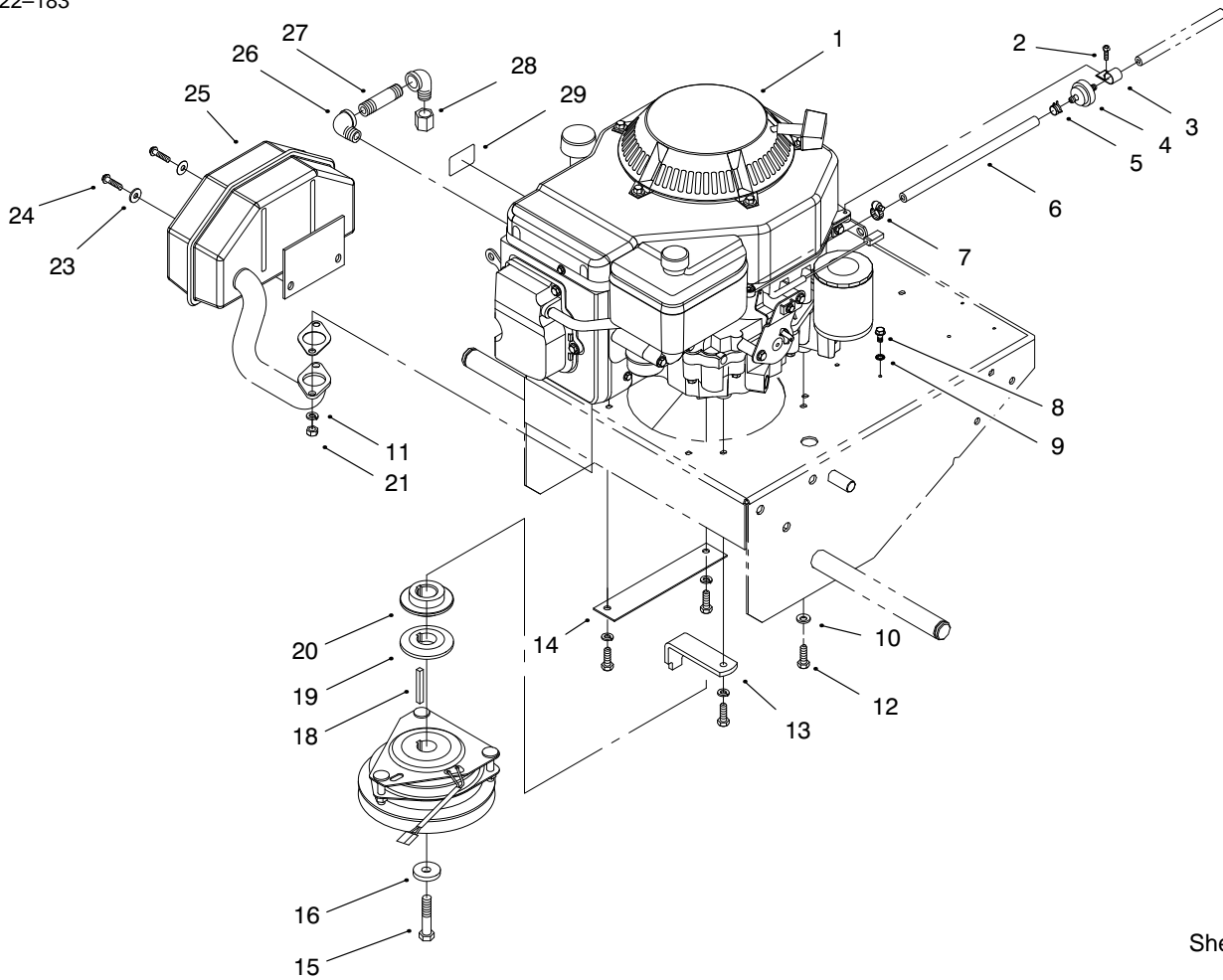

Sheet No.: 6

Engine Assembly

Ref. No.	Part No.	Qty.	Description
1		1	Engine-15 Hp Kohler
2	32144-19	1	Screw-HH
3	2412-87	1	Clamp-Cable
4	56-6360	1	Filter-Fuel
5	2412-98	1	Clamp-Hose
6	47-2982	1	Hose-Fuel
7	2412-108	1	Clamp-Hose
8	12-3270	1	Screw-HH
9	3255-7	1	Washer-Lk
10	3256-23	1	Washer-Flat
11	3253-4	2	Washer-Lock
12	57-6380	4	Screw-HH
13	51-4540-03	1	Retainer-Clutch
14	74-0930-01	1	Guard-Pulley
15	3212-9	1	Screw-HH
16	112843	1	Washer-PTO
18	608006	1	Key
19	74-0050	1	Sheave-Lower
20	74-0060	1	Sheave-Upper
23	3256-78	2	Washer-Plain
24	93-7033	2	Screw
25	95-5517	1	Muffler (Supplied w/Eng)
26	74-0950	2	Elbow
27	289-51	1	Nipple-Pipe

Ref. No.	Part No.	Qty.	Description
28	288-4	1	Cap-Pipe
29	63-8440	1	Decal-Hot Surface

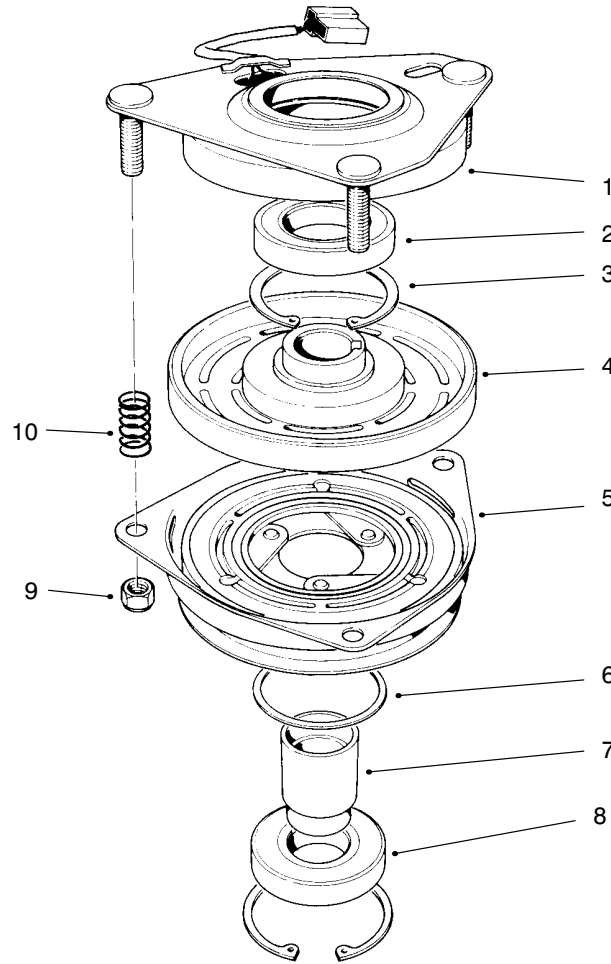

Sheet No.: 301

Clutch Asm No. 54-3200

Ref. No.	Part No.	Qty.	Description
1	54-0230	1	Field ASM Inc2/3
2	251-292	1	Bearing
3	44-8310	2	Ring-Retaining
4	44-8360	1	Field Coil & Bearing
5	55-7410	1	Armature & Pulley ASM
6	44-8330	1	Spacer-Pulley Bearing
7	44-8340	1	Collar-Bearing
8	251-291	1	Bearing-Pulley
9	3296-5	3	Nut-Lock
10	44-8320	3	Spring

Ref. No.	Part No.	Qty.	Description

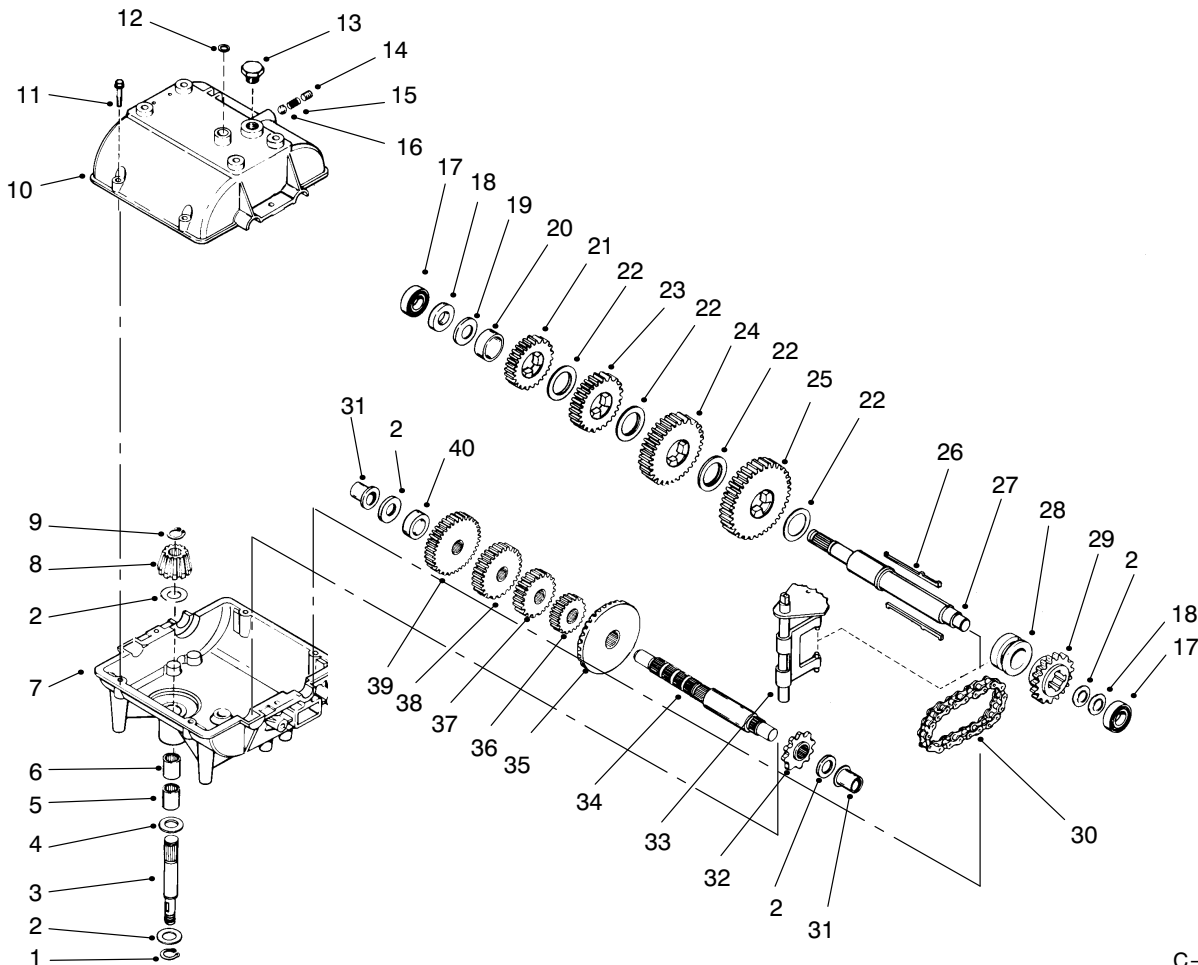

C-1776

Peerless Transmission Model 700-082

Ref. No.	Part No.	Description	No. Used
1	792035	Ring - Retaining	1
2	780072	Washer - Thrust	5
3	776135	Shaft - Input	1
4	792001	"O"Ring	2
5	780142	Bearing - Needle	1
6	780086A	Bearing - Needle	1
7	770090A	Case - Transmission	1
8	778153	Bevel Pinion - Input	1
9	788040	Ring - Retaining	1
10	772099A	Cover - Transmission	1
11	792073A	Screw - Self Tapping	6
12	788069	Seal - Square Cut	1
13	792074	Plug - Threaded	1
14	792078	Screw - Set	1
15	792079	Spring	1
16	792077A	Ball - Steel	1
17	780092	Bearing - Ball	2
18	780065	Washer - Thrust	2
19	780139	Washer - Thrust	1
20	786072	Spacer	1
21	778123A	Gear - Spur (25 Teeth)	1
22	780108	Washer - Thrust	4

Ref. No.	Part No.	Description	No. Used
23	778250	Gear - Spur (27 Teeth)	1
24	778124A	Gear - Spur (30 Teeth)	1
25	778125	Gear - Spur (35 Teeth)	1
26	792089A	Key	4
27	776421	Shaft - Shifter & Brake	1
28	784266	Collar - Shift	1
29	786083	Sprocket (18 Teeth)	1
30	786081	Chain - Roller (No. 41 Chain 24 Links)	1
31	780105A	Bushing - Flanged	2
32	786082	Sprocket (9 Teeth)	1
33	784267	Rod & Fork Asm - Shift	1
34	776134	Shaft - Counter	1
35	778154	Gear - Bevel (42Teeth)	1
36	778136	Gear - Spur (15 Teeth)	1
37	778126A	Gear - Spur (20 Teeth)	1
38	778249	Gear - Spur (23 Teeth)	1
39	778127A	Gear - Spur (25 Teeth)	1
40	786071	Spacer	1
*	788067B	Grease 32oz Bottle	1
*	510334	Grease Eliminator	1

Peerless transmission
Order Part's from Peerless

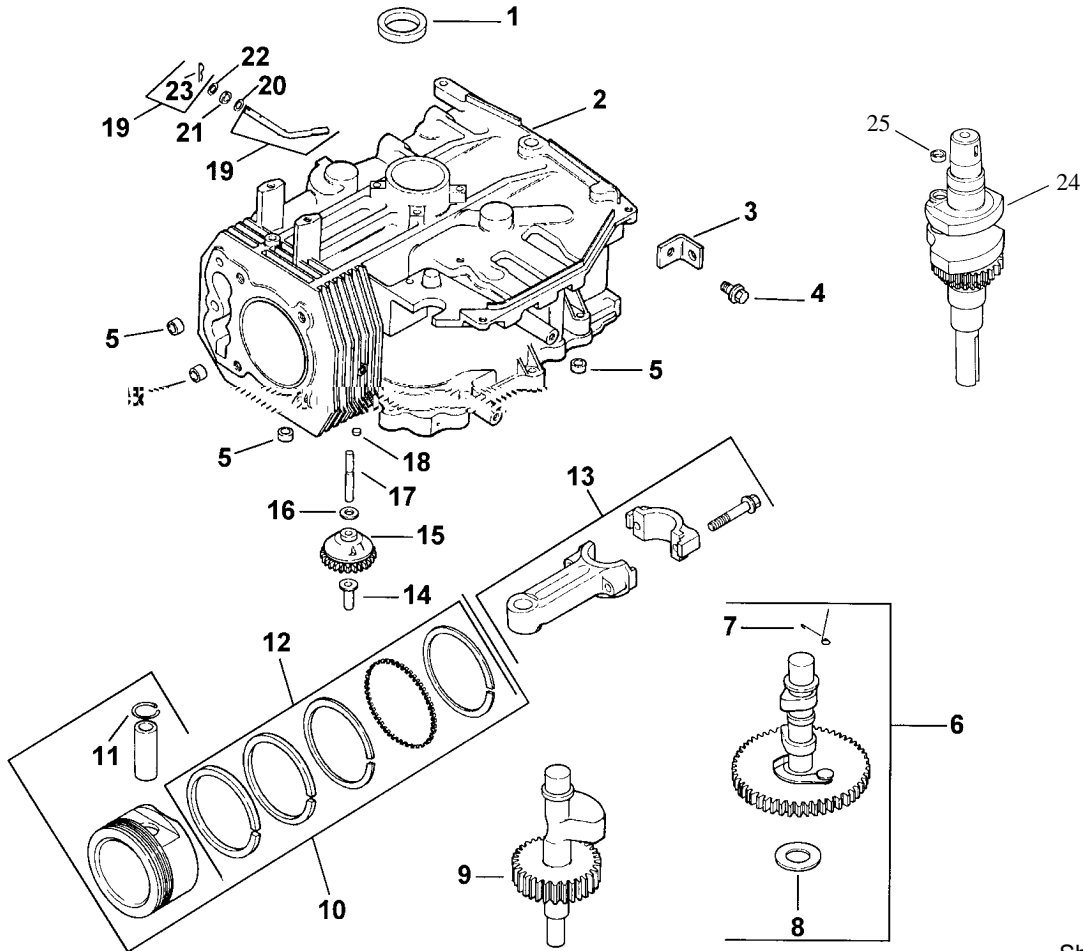

Sheet No.: 2 01

Crankcase

Ref. No.	Part No.	Qty.	Description
1	12 032 03	1	Seal-Crankshaft
2	12 522 18	1	Shortblock
3	12 445 02	1	Strap-Lifting
4	M-0839025	1	Screw M8x1.25x22
5	12 380 17	4	Dowel-Locating
6	12 755 49	1	Kit-Camshaft INC 7-8
7	12 089 31	1	Spring-Actuating
8	12 422 07	A/R	Shim-Camshaft A/R
8	12 422 08	1	Shim-Camshaft A/R
8	12 422 09	A/R	Shim-Camshaft A/R
8	12 422 10	A/R	Shim-Camshaft A/R
8	12 422 11	A/R	Shim-Camshaft A/R
8	12 422 12	A/R	Shim-Camshaft A/R
8	12 422 13	A/R	Shim-Camshaft A/R
9	12 144 27	1	Shaft-Balance
10	12 847 07	1	Set Piston w/Ring STD
10	12 847 08	1	Set-Piston w/Ring .25
10	12 847 09	1	Set-Piston w/Ring .50
11	12 018 02	2	Retainer-Piston Pin
12	12 108 07	1	Ring Set STD
12	12 108 08	1	Ring Set .25
12	12 108 09	1	Ring Set .50
13	12 067 05	1	Rod Connecting STD
13	12 067 06	1	Rod Connecting .25

Ref. No.	Part No.	Qty.	Description
14	12 380 01	1	Pin-Governor Regulating
15	12 043 05	1	Gear-Governor ASM
16	M-0631005	1	Washer-Governor
17	12 144 02	1	Shaft-Governor Gear
18	52 139 09	1	Plug-Cup
19	12 755 64	1	Kit - Shaft-Governor Cross (Incl. Ref.#23)
20	X-25-102	1	Washer-Flat
21	12 032 01	1	Seal-Governor Shaft
22	M-0631015	1	Washer-Governor Shaft
23	12 154 05	1	Clip - Hitch Pin
24	12 014 30	1	Crankshaft ASM
25	12 139 01	1	Plug-Cup
*	12 030 02	1	Bearing - Crankshaft 0.25
*	12 030 03	1	Bearing - Crankshaft 0.50
*	12 755 82	1	Set - Gasket

* Not Illustrated

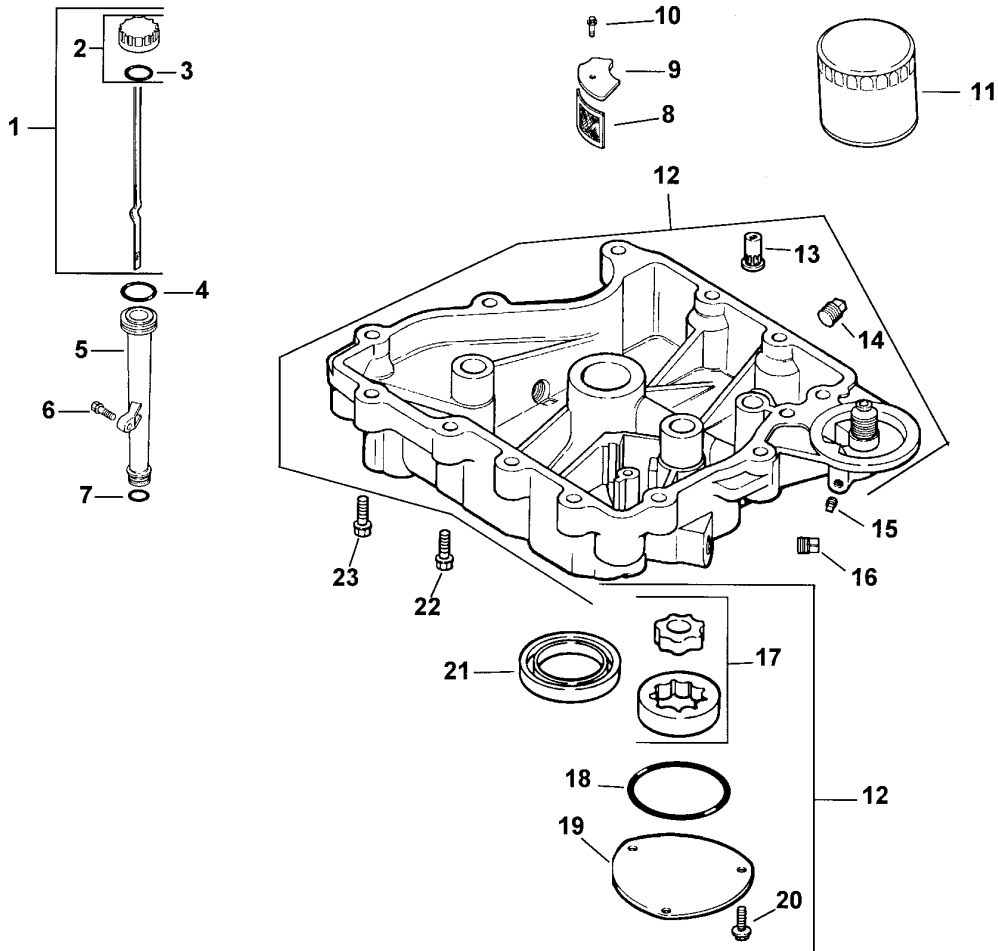

Sheet No.: 2 02

Oil Pan / Lubrication

Ref. No.	Part No.	Qty.	Description
1	12 038 01	1	Dipstick INC 2-3
2	25 755 13	1	Kit-Oil Cap INC 3
3	12 153 03	1	O Ring-Fill Cap
4	12 153 02	1	O Ring-Upper Fill Tube
5	12 123 04	1	Tube-Oil Fill
6	M-0545020	1	Screw M5x0.8x20
7	12 153 01	2	O Ring-Lower Fill Tube
8	25 162 07	1	Screen-Oil
9	12 096 03	1	Cover-Oil Pickup Screen
10	M-0545016	1	Screw M5x0.8x16
11	52 050 02	1	Filter-Oil
12	12 199 45	1	Pan - Oil (Incl. Ref. #13, 14, 17-20)
13	25 462 09	1	Valve - Oil Pressure
14	X-75-2	2	Plug-1/4nptf
15	X-75-1	2	Plug-1/8nptf
16	X-75-10	2	Plug-SH 3/8 NPTF
17	12 393 01	1	Pump-Oil
18	12 153 06	1	O Ring-Oil Pump Cover
19	12 096 34	1	Cover-Oil Pump
20	M-0545016	3	Screw M5x0.8x16
21	12 032 03	1	Seal-Crankshaft

Ref. No.	Part No.	Qty.	Description
22	24 086 16	11	Screw-M8X1.25X45
23	24 068 17	1	Screw-M5X1.25X45

* Not illustrated

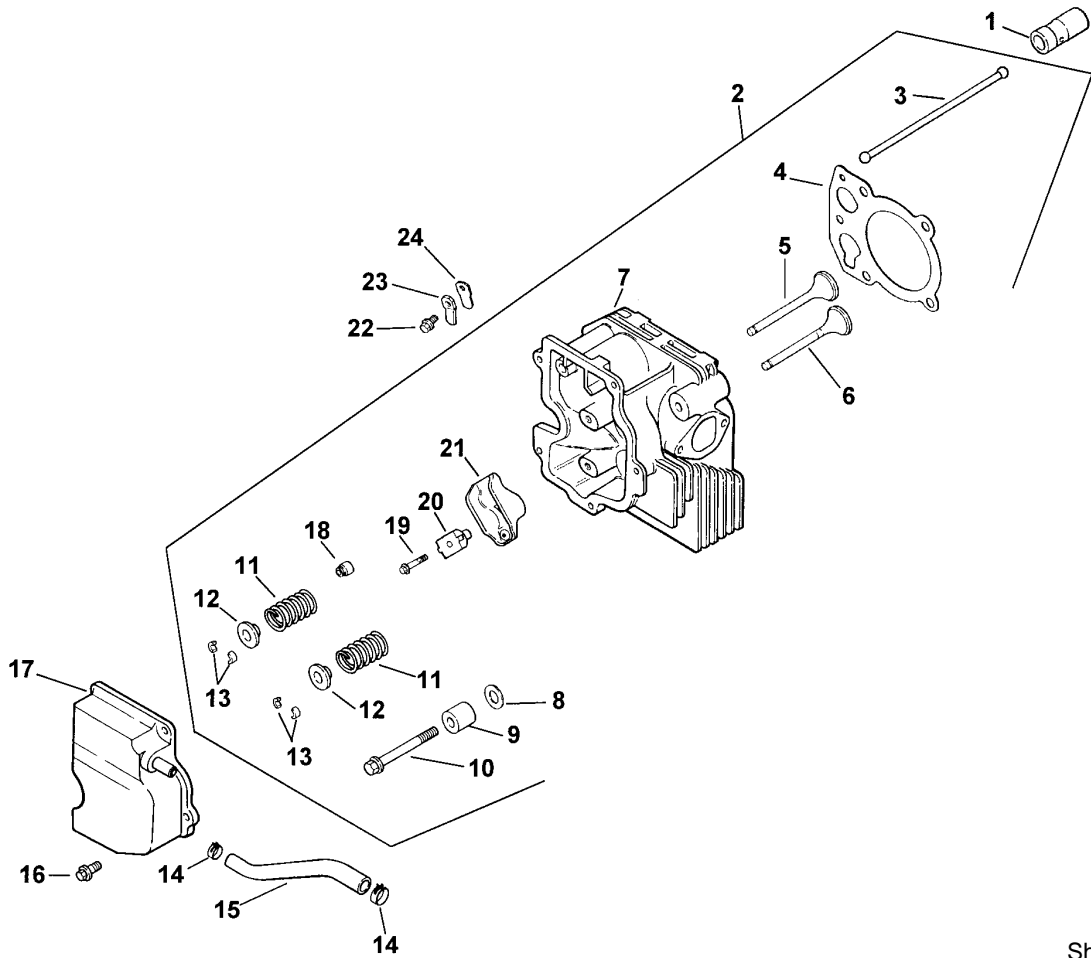

Sheet No.: 2 03

Cylinder Head, Valves And Breather

Ref. No.	Part No.	Qty.	Description
1	12 351 02	2	Lifter-Valve
2	12 755 81	1	Kit-Cylinder Head
3	12 411 01	2	Rod-Push
4	12 041 10	1	Gasket-Cylinder Head
5	12 017 01	1	Valve-Intake STD
5	12 017 02	1	Valve-Intake .25
6	12 016 01	1	Valve-Exhaust STD
6	12 016 02	1	Valve-Exhaust .25
7	12 318 19	1	Head - Cylinder
8	12 468 05	1	Washer-Flat
9	12 112 13	1	Spacer-Head Bolt Exhaust
10	12 086 15	5	Screw M10x1.5x80
11	12 089 01	1	Spring-Valve
12	12 173 01	2	Cap-Valve Spring
13	12 755 03	2	Kit-Retainer
14	X-426-9	2	Clamp-Hose
15	12 326 03	1	Hose-Breather
16	M-0645020	3	Screw-HH M6x1.0x20
17	12 096 07	1	Cover-Valve w/Nipple
18	24 023 05	1	Seal-Valve Spring
19	M-0640034	2	Screw M6x1.0x34
20	12 599 03	2	Pivot - Rocker Arm
21	25 186 01	2	Arm-Rocker
22	M-0545010	1	Screw M5x0.8x10

Ref. No.	Part No.	Qty.	Description
23	12 018 01	1	Retainer-Breather Reed
24	12 402 02	1	Reed-Breather

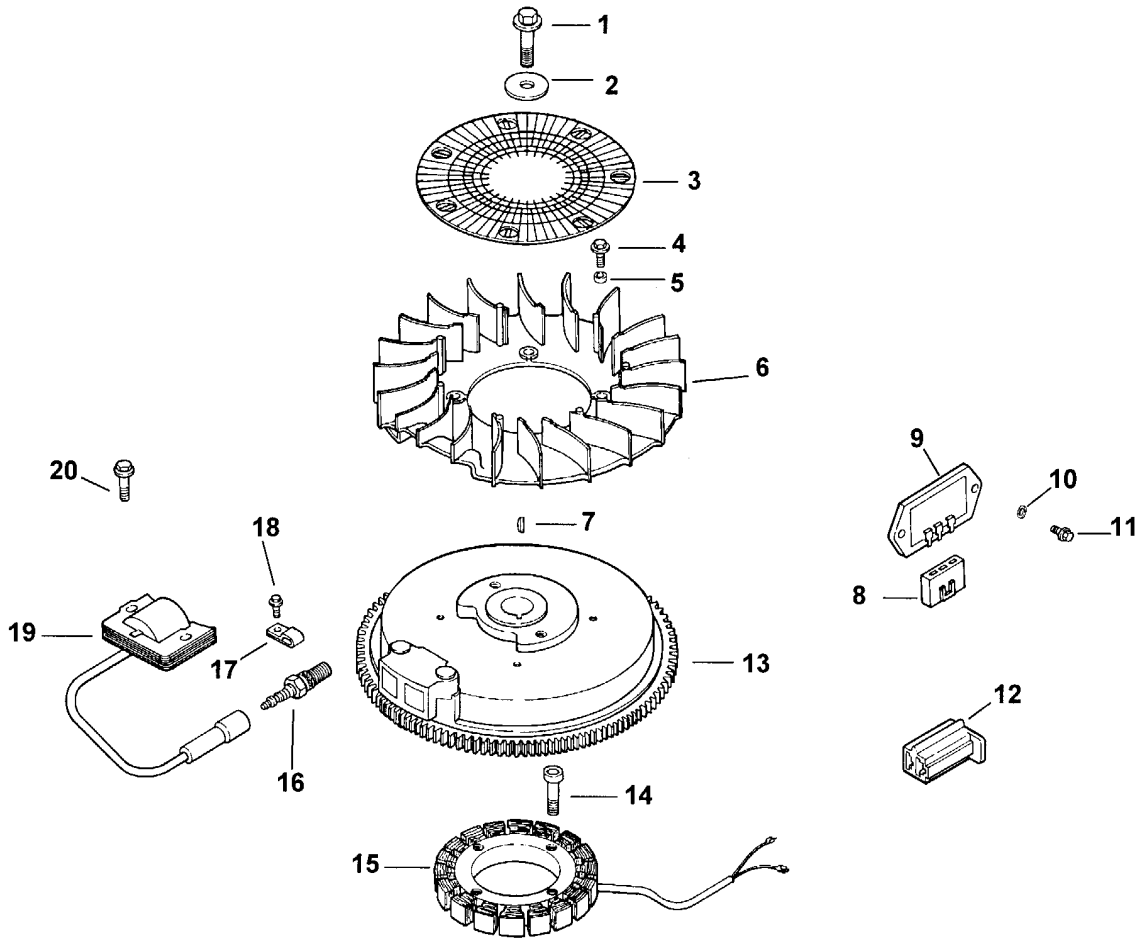

Sheet No.: 2 04

Ignition / Electrical

Ref. No.	Part No.	Qty.	Description
1	12 086 14	1	Screw-Flywheel Mounting
2	12 486 03	1	Washer-Flat
3	12 162 03	1	Screen-Grass
4	M-0639016	4	Screw M6x1.0x16
5	12 112 01	4	Spacer-Fan
6	12 157 02	1	Fan
7	X-42-15	1	Key
8	236602	1	Connector-Regulator
9	12 403 01	1	Rectifier-Unregulated
10	X-22-11	2	Washer - Lock
11	M-0639016	2	Screw M6x1.0x16
12	41 155 03	1	Connector
13	12 025 33	1	Flywheel ASM
14	M-0548025	4	Screw M5x0.8x25
15	54 755 09	1	Kit - Stator-15 Amp (Incl. Bracket P/N #24 126 71)
16	12 132 02	1	Spark Plug
17	X-728-1	2	Clip-Kill Lead
18	M-0545010	1	Screw M5x0.8x10
19	12 584 02	1	Module-Ignition
20	M-0545020	2	Screw M5x0.8x20
*	X-25-5	1	Washer
*	12 518 01	1	Lead-White
*	25 518 05	1	Lead-Black

Ref. No.	Part No.	Qty.	Description
*	25 518 29	1	Lead-Black
*	24 126 71	1	Bracket - Stator Wire

* Not illustrated

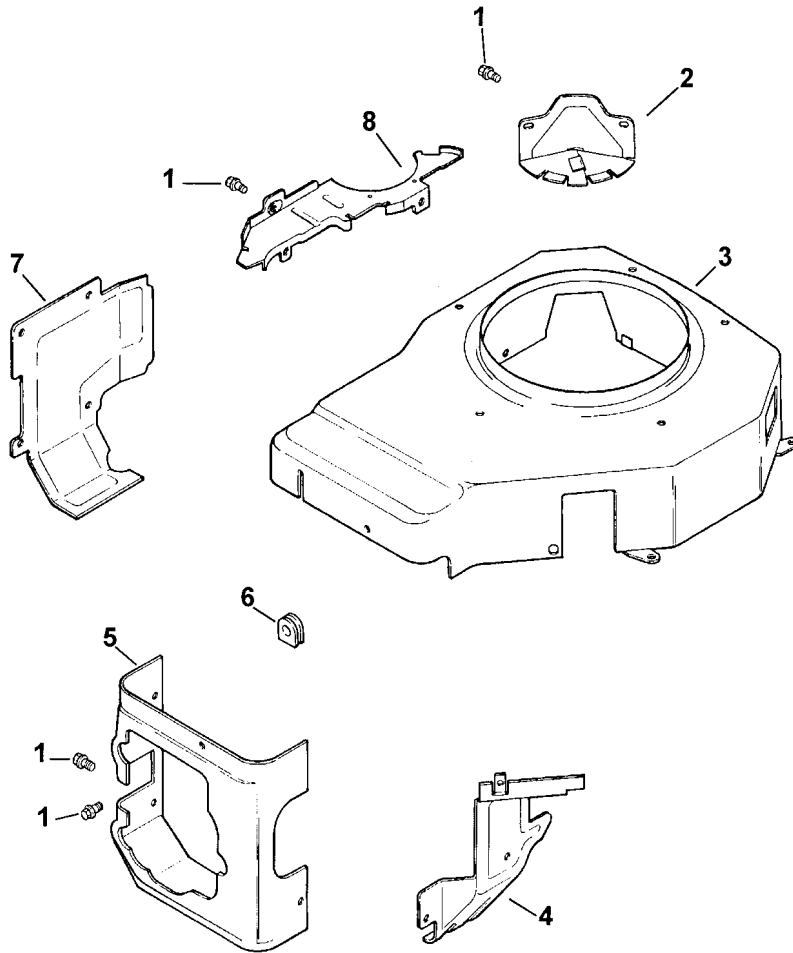

Sheet No.: 2 05

Blower Housing And Baffles

Ref. No.	Part No.	Qty.	Description	Ref. No.	Part No.	Qty.	Description
1	M-0545010	15	Screw M5x0.8x10				
2	12 096 29	1	Cover- Starter				
3	12 027 37	1	Housing- Blower				
4	12 063 05	1	Baffle- Carburetor				
5	12 063 08	1	Baffle- Cyl. Head				
6	12 313 03	1	Grommet- Blower				
7	12 063 01	1	Baffle- Cylinder				
8	12 146 07	1	Plate- Blower Housing				
*	12 133 67	1	Decal- Horsepower				

* Not illustrated

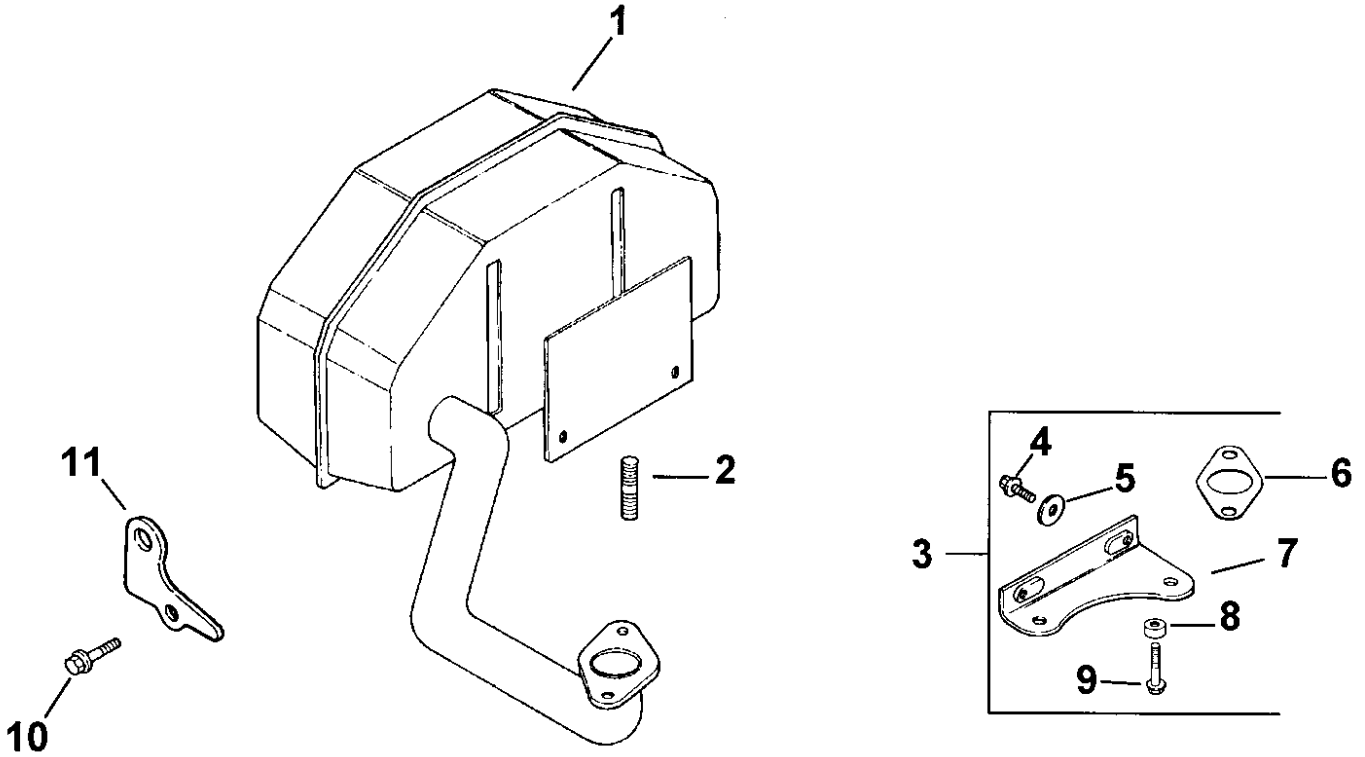

Sheet No.: 2 10

Exhaust

Ref. No.	Part No.	Qty.	Description
1	12 068 03	1	Muffler
2	M-0829033	2	Stud M8x1.25x20
3	12 755 30	1	Kit-Bracket (Incl. Ref.#4-9)
4	M-0650012	2	Screw
5	X-25-52	2	Washer
6	12 041 03	1	Gasket - Exhaust
7	12 126 55	1	Bracket-Muffler
8	12 468 01	1	Washer
9	12 086 13	1	Screw
10	M-0645025	1	Screw
11	12 445 06	1	Strap-Lifting

Ref. No.	Part No.	Qty.	Description

* Not illustrated

Toro Part Number Index

Part No.	Page No.	Ref. No.	Qty.	Description
112843	6	16	1	Washer-PTO
608006	6	18	1	Key
7-5461	2	29	1	Spacer-Transmission
10-8110	3	10	A/R	Washer-Thrust
12-3270	6	8	1	Screw-HH
26-9671	2	17	1	"v" Belt
27-6230	2	19	1	Bolt-Wheel
29-5560	5	23	1	Switch-On/Off
47-1970	2	2	1	Grip-Engagement
47-2964	1	35	1	Hose-Gas
47-2982	6	6	1	Hose-Fuel
51-4160	3	14	4	Pulley-Wheel
51-4170	3	13	8	Spacer-Pulley
51-4180	3	15	2	Drum-Brake
51-4190	2	16	1	Pulley-Drive
51-4220	2	12	2	Guard-Coupler
51-4230	3	19	2	Washer-Wheel
51-4270	2	5	2	Bearing-Shaft Ext
51-4290	3	12	2	Belt-Drive
51-4370	1	7	1	Spring-RH
51-4380	1	8	1	Spring-LH
51-4450	1	24	2	Screw-Leveler
51-4540-03	6	13	1	Retainer-Clutch
51-4580	3	1	2	Rod-Brake
51-4600	3	3	1	Brake-Arm RH
51-4610	3	4	1	Brake Arm-LH
51-4650	3	8	2	Link-Brake
51-4660	3	7	2	Plate-Brake Link
51-4700	3	17	2	Band-Brake
51-4850	5	37	1	Lever-Parking Brake
52-2010	5	38	1	Decal-Parking Lever
52-2890	1	11	2	Bushing-Flanged
55-3570	1	1	1	Cap-Fuel
56-6360	6	4	1	Filter-Fuel
57-6380	6	12	4	Screw-HH
62-4540-03	2	22	1	Pulley-Idler
63-7590	5	15	1	Relay
63-8360	5	12	2	Key-Ignition
63-8440	6	29	1	Decal-Hot Surface
65-3090	5	20	1	Decal-Manual
66-7400	1	32	1	Plate-Control
67-6370	1	17	1	Bracket-RH
67-6380	1	18	1	Bracket-LH
67-6440	5	9	1	Handle-Upper
68-2190	2	18	1	Spring-Extension
68-9690	1	25	2	Fitting Rod
71-1280	5	34	1	Decal-Warning
72-2190	2	28	1	Mount-Shift Lever
74-0040	1	6	4	Spacer-Pivot
74-0050	6	19	1	Sheave-Lower
74-0060	6	20	1	Sheave-Upper
74-0220	1	14	1	Idler Bracket LH
74-0230	1	13	1	Idler Bracket RH
74-0320	2	1	1	Lever-Shift
74-0360	1	34	1	Frame-Rear
74-0480	2	11	2	Pulley-Drive ASM
74-0521	1	15	2	Rod-Fitting
74-0630	5	21	1	Control-Throttle
74-0720	5	29	1	Tube-Manual
74-0930-01	6	14	1	Guard-Pulley
74-0950	6	26	2	Elbow
82-2180-03	5	28	1	Panel-Control

*Not Illustrated

Toro Part Number Index (cont.)

Part No.	Page No.	Ref. No.	Qty.	Description
82-2190	5	39	1	Switch-Bail
82-2280	5	7	1	Decal-Reverse
82-2290	5	2	1	Decal-Control Bar
82-2300	5	11	1	Switch
82-3820	5	10	1	Boot-Switch
82-4800	2	21	1	Lever-Idler
82-7631	5	35	2	Rod-Control
82-7680-03	5	4	1	Bail
82-7690	5	1	1	Bar
82-7730	5	33	1	Decal-Panel Proline
82-7750	1	4	1	Decal-Ground Speed
92-1746	4	4	4	Bearing
93-1156	1	29	1	Frame
93-1187-03	5	16	1	Panel-Bottom
94-9663	3	9	2	Wheel & Tire ASM
94-9666	5	17	1	Module
95-1526	2	31	1	Shield-Trailing
95-1529	2	32	1	Rod-Shield
95-2800	1	22	2	Pulley-Idler
95-2801	1	23	2	Spacer-Pulley
95-2802	1	2	1	Tank-Fuel
95-2803	5	25	1	Wire Harness
95-2814	1	33	1	Decal-Fuel Shut-Off
95-2833	6	1	1	Engine-15 Hp Kohler
95-5517	6	25	1	Muffler (Supplied w/Eng)
98-0787	2	8	1	Shaft-LH
98-0788	2	7	1	Shaft-RH
98-0789	2	13	2	Coupler
98-0791	2	27	1	Transmission-4 Speed
99-8501	5	6	1	Control Pivot
218-461	5	13	1	Nut-HH (F/W Sw)
218-595	5	36	1	Connector-Body
231-117	4	5	2	Tire-15x6
232-27	4	6	2	Valve Stem
237-124	1	26	1	Grommet
237-141	5	41	2	Grommet
242-80	4	1	2	Rim
2412-87	6	3	1	Clamp-Cable
2412-98	1	3	2	Clamp-Hose
2412-98	6	5	1	Clamp-Hose
2412-108	6	7	1	Clamp-Hose
2412-120	5	26	2	Clamp-R
283-6	1	16	2	Pin-Clevis
283-55	5	19	2	Pin-Clevis
288-4	6	28	1	Cap-Pipe
289-51	6	27	1	Nipple-Pipe
302-5	2	14	2	Fitting-Grease
302-11	4	2	2	Fitting-Grease
321-2	5	18	1	Screw-HH
321-4	2	6	4	Screw-HH
322-2	2	24	4	Screw-HH
322-4	1	30	4	Screw-HH
322-7	3	18	8	Screw-HH
323-6	1	20	6	Screw-HH
323-8	2	20	1	Screw-HH
323-16	1	19	2	Screw-HH
329-10	2	30	1	Screw
3212-9	6	15	1	Screw-HH
3234-11	5	31	4	Screw-HHF
3245-1	2	15	1	Screw-Set
3245-3	2	10	2	Screw-HSH
3253-4	1	31	4	Washer-Lock

*Not Illustrated

Toro Part Number Index (cont.)

Part No.	Page No.	Ref. No.	Qty.	Description
3253-4	2	25	4	Washer-Lock
3253-4	3	16	8	Washer-Lock
3253-4	6	11	2	Washer-Lock
3254-5	5	22	1	Washer-Lock
3255-7	6	9	1	Washer-Lk
3256-23	1	10	10	Washer-Flat
3256-23	6	10	1	Washer-Flat
3256-78	6	23	2	Washer-Plain
3257-5	2	9	3	Key-Woodruff
3269-8	1	28	2	Rivet
3272-11	5	8	2	Pin-Cotter
3290-307	1	12	4	Pin-Cotter
3290-307	3	2	2	Pin-Cotter
3290-307	5	40	2	Pin-Cotter
3290-378	5	24	2	Tie-Cable
3296-2	5	3	5	Nut-Lock
3296-6	2	26	1	Nut-Lock
3296-23	1	21	2	Nut-Lock
3296-29	4	3	8	Nut-Lock
3296-39	1	5	8	Nut-Lock
3296-39	2	23	1	Nut-Lock
3296-42	2	3	4	Nut-Lock
3296-42	5	14	1	Nut-Lock
32103-25	1	9	2	Nut-Wing
32104-76	5	27	4	Screw-Self TAP
32105-1	5	5	1	Screw-HH
32105-14	5	32	4	Screw-HH
32120-64	2	4	1	Ring-Retaining
32128-21	5	30	4	Nut-HF
32144-19	6	2	1	Screw-HH
32151-40	3	5	2	Ring-Retaining
32151-56	3	6	2	Ring-Retaining
32151-62	2	33	2	Ring-Retaining
32151-72	3	20	4	Ring-Retaining
32151-91	3	11	2	Ring-Retaining

*Not Illustrated

