



GROUNDSMASTER®

52" Mower

for 120 Traction Unit

Model No. 30753 – 990001 & UP

Operator's Manual

IMPORTANT: Read this manual carefully. It contains information about your safety and the safety of others. Also become familiar with the controls and their proper use before you operate the product.

Introduction

We want you to be completely satisfied with your new product, so feel free to contact your local Authorized Service Dealer for help with service, genuine replacement parts, or other information you may require.

Whenever you contact your Authorized Service Dealer or the factory, always know the model and serial numbers of your product. These numbers will help the Service Dealer or Service Representative provide exact information about your specific product. You will find the model and serial number plate located in a unique place on the product as shown below.

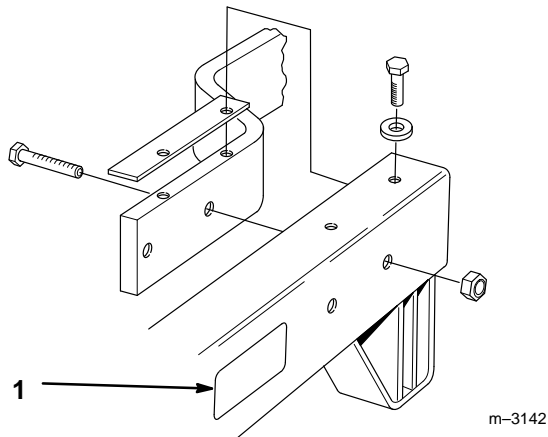

1. Model and Serial Number Plate

For your convenience, write the product model and serial numbers in the space below.

Model No: _____
Serial No. _____

The warning system in this manual identifies potential hazards and has special safety messages that help you and others avoid personal injury, even death. DANGER, WARNING and CAUTION are signal words used to identify the level of hazard. However, regardless of the hazard, be extremely careful.

DANGER signals an extreme hazard that will cause serious injury or death if the recommended precautions are not followed.

WARNING signals a hazard that may cause serious injury or death if the recommended precautions are not followed.

CAUTION signals a hazard that may cause minor or moderate injury if the recommended precautions are not followed.

Two other words are also used to highlight information. “Important” calls attention to special mechanical information and “Note” emphasizes general information worthy of special attention.

The left and right side of the machine is determined by sitting on the seat in the normal operator’s position.

Contents

	Page		Page
Safety and Instruction Decals	2	Maintenance	8
Assembly	3	Service Interval Chart	8
Loose Parts	3	Cutting Blades	8
Installing the Castor Wheels	4	Correcting Cutting Unit Mismatch	11
Installing the Carrier Frame to the Traction Unit	4	Setting the Front-to-Rear Pitch	11
Installing the Cutting Mower	5	Setting the Side-to-Side Leveling	12
Installing the Drive Belt	5	Greasing and Lubrication	13
Operation	6	Replacing the Mower Belt	14
Operating the Power Take Off (PTO)	6	Replacing the Drive Belt	15
Implement Lift Lever	7	Replacing the Grass Deflector	15
Adjusting Gage Wheels	7	Replacing the Castor Wheel Fork Bushings	16
		Servicing the Castor Wheels and Bearings	17
		Storage	18
		Troubleshooting	19

Safety and Instruction Decals



Safety decals and instructions are easily visible to the operator and are located near any area of potential danger. Replace any decal that is damaged or lost.

**ON FRONT OF MOWER
(Part No. 66-1340)**



**ON CENTER OF MOWER,
UNDER SHIELDS
(Part No. 67-5360)**



**ON REAR OF MOWER
(Part No. 68-8340)**

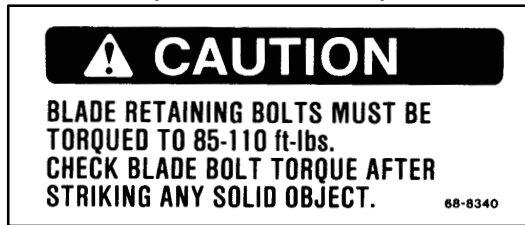

**ON DEFLECTOR
(Part No. 93-1122)**



**ON LEFT SIDE OF
MOWER
(Part No. 43-8480)**



**UNDER DEFLECTOR
(Part No. 66-6380)**



**ON SIDES OF MOWER FRAME
(Part No. 68-8360), Left Side
(Part No. 79-0940), Right Side**

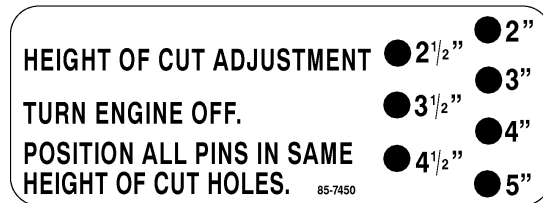

**ON LEFT SIDE OF MOWER
(Part No. 68-7260)**



Assembly

Loose Parts

Note: Use the chart below to identify parts used for assembly.

DESCRIPTION	QTY.	USE
Carrier frame	1	Install carrier frame to traction unit
Shim	2	
Bolt 3/8–16 x 7/8" (22 mm)	4	
Washer 3/8" (10 mm)	4	
Bolt 3/8–16 x 1-3/4" (44 mm)	4	
Locknut 3/8–16	4	
Castor wheel assembly	2	Install castor wheels to carrier frame
Thrust washer	8	
Retaining pin	2	
Drive belt	1	Install cutting unit to carrier frame
Clevis pin	4	
Hairpin cotter	4	
Operator's Manual	1	Read before operating
Parts Catalog	1	Ordering parts

Installing the Castor Wheels

1. Place the (2) thrust washers onto the castor wheel fork (Fig. 1).
2. Insert the castor wheel fork into the carrier frame mounting tube (Fig. 1).
3. Install (2) thrust washer onto the castor wheel fork, then secure with a retaining ring (Fig. 1).

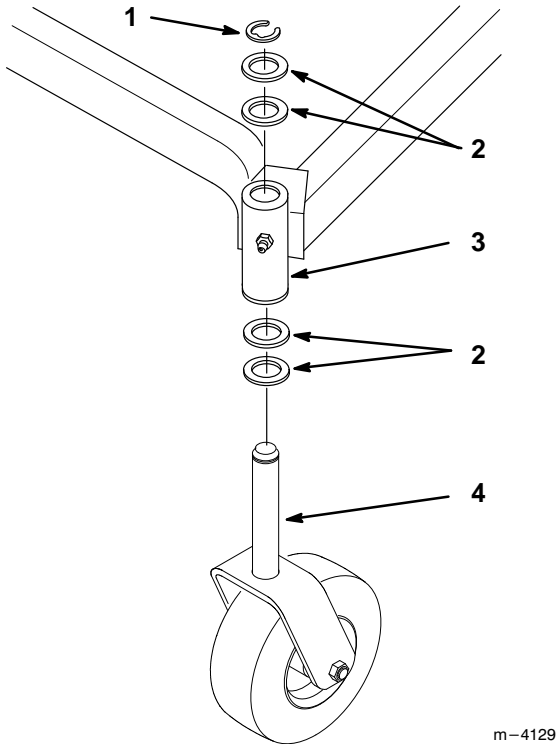

Figure 1

- | | |
|----------------------|--------------------------------|
| 1. Retaining ring | 3. Carrier frame mounting tube |
| 2. Thrust washer (4) | 4. Castor wheel fork |

Installing the Carrier Frame to the Traction Unit

1. Align the carrier frame and shim holes with the mounting holes in the traction unit frame (Fig. 2).
2. Fasten each side of the carrier frame to the traction unit with (2) 3/8-16 x 7/8" (22 mm) bolts and washers, down from the top, and (2) 3/8-19 x 1-3/4" (44 mm) bolts and 3/8-16 locknuts, through the side (Fig. 2).
3. Torque the mounting screws to 240-320 in-lb (27-36 N•m) (Fig. 2).

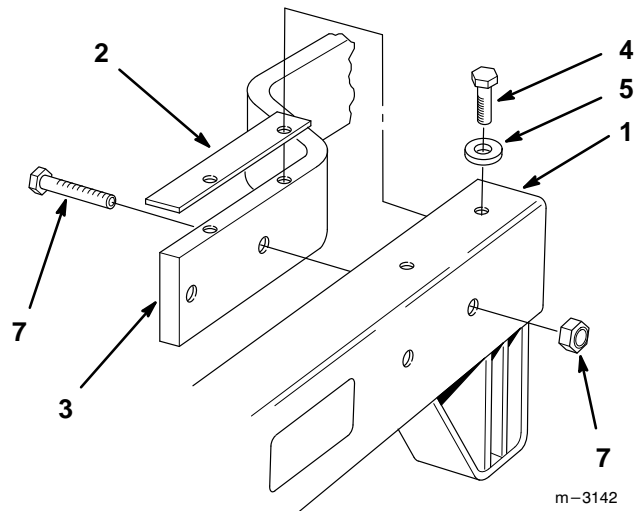

Figure 2

- | | |
|------------------------------|---------------------------------|
| 1. Carrier frame | 5. Washer 3/8" (10 mm) |
| 2. Shim | 6. Bolt 3/8-16 x 1-3/4" (44 mm) |
| 3. Traction unit frame | 7. Locknut 3/8-16 |
| 4. Bolt 3/8-16 x 7/8 (22 mm) | |

4. Set the castor wheel tire pressure to 25–30 psi (172–207 kPa).

Installing the Cutting Mower

1. Position mower under the carrier frame.
2. Mount the mower to the carrier frame with four (4) clevis pins and hairpin cotters (Fig. 3).

Note: All four pins must be in the same hole locations to prevent uneven cutting.

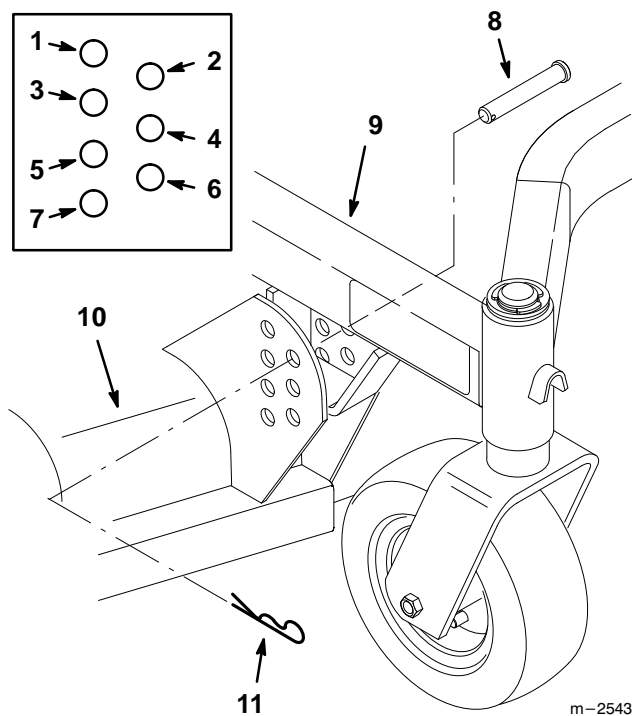

Figure 3

- | | |
|------------------------------|---------------------------|
| 1. 1" (25 mm) Cut height | 7. 4" (102 mm) Cut height |
| 2. 1-1/2" (39 mm) Cut height | 8. Clevis pin |
| 3. 2" (51 mm) Cut height | 9. Carrier frame |
| 4. 2-1/2" (64 mm) Cut height | 10. Mower |
| 5. 3" (76 mm) Cut height | 11. Hairpin cotter |
| 6. 3-1/2" (89 mm) Cut height | |

Installing the Drive Belt

1. Release latches holding covers to the top of the mower, over gearbox pulley, and remove.
2. Install the drive belt around the jackshaft pulley, on the traction unit, and the gearbox pulley. Raise the idler pulley and position over the upper portion of the drive belt (Fig. 4).
3. Install mower covers and secure latches.

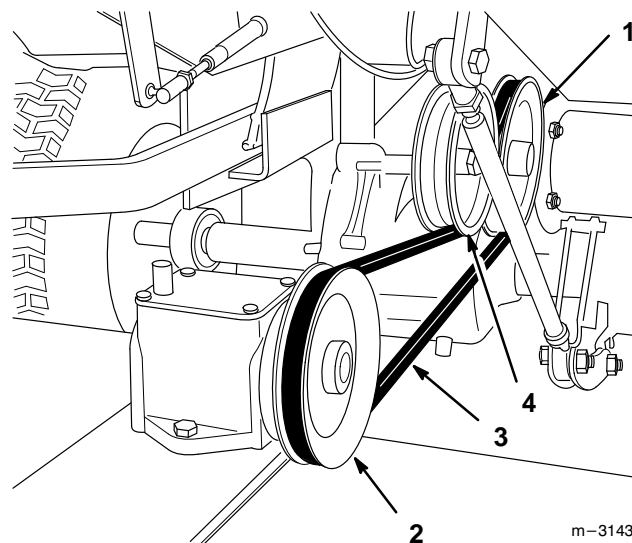

Figure 4

- | | |
|---------------------|-----------------|
| 1. Jackshaft pulley | 3. Drive belt |
| 2. Gearbox pulley | 4. Idler pulley |

! DANGER

POTENTIAL HAZARD

- When the mower is attached to the traction unit, without additional weight, the traction unit may become unstable.

WHAT CAN HAPPEN

- Loss of traction and stability may cause loss of control.

HOW TO AVOID THE HAZARD

- **NEVER** operate the traction unit with mower attached, unless rear weight is installed.

Operation

DANGER

POTENTIAL HAZARD

- When the mower is attached to the traction unit, without additional weight, the traction unit may become unstable.

WHAT CAN HAPPEN

- Loss of traction and stability may cause loss of control.

HOW TO AVOID THE HAZARD

- NEVER operate the traction unit with mower attached, unless rear weight is installed.

Operating the Power Take Off (PTO)

The power take off (PTO) switch engages and disengages power to the electric clutch.

Engaging the PTO

1. Release the parking brake.
2. Release pressure on the traction pedal to stop movement (Fig. 5).
3. To engage lift cover and move the PTO switch to the “ON” position (Fig. 5).

Disengaging the PTO

1. Closing the cover moves the PTO switch to the “OFF” position (Fig. 5).

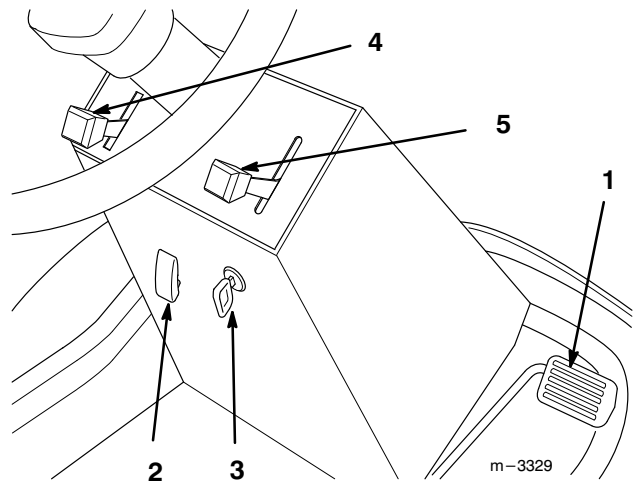

Figure 5

- | | |
|--------------------|-------------|
| 1. Traction pedal | 4. Choke |
| 2. PTO switch | 5. Throttle |
| 3. Ignition switch | |

Implement Lift Lever

The implement lift lever (Fig. 6) is used to raise and lower various attachments.

Raising Attachments

1. Remove pressure from traction pedal to stop the machine.
2. Pull implement lift lever (Fig. 6) rearward to raise attachment to the desired height.

Lowering Attachments

1. Remove pressure from traction pedal to stop the machine.
2. Push implement lift lever (Fig. 6) forward to lower attachment.

Note: Hold lift lever in down position 1–2 seconds after attachment in down to extend lift cylinder allowing attachment to float with changes in ground contour.

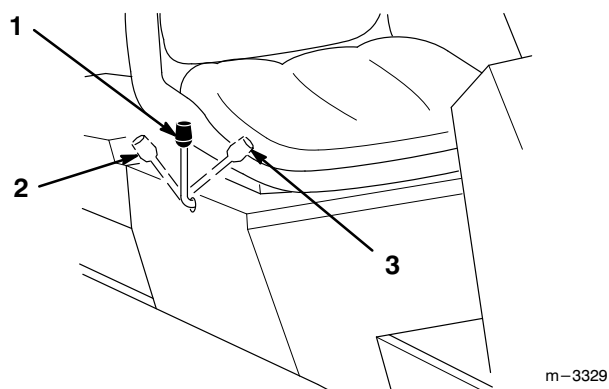

Figure 6

1. Lift lever
2. Lift-raise
3. Lift-lower

Adjusting Gage Wheels

The gage wheels must be adjusted in the proper hole location for each height-of-cut position.

1. After adjusting height-of-cut, raise the attachment lift lever: Refer to Raising Attachments.
2. Remove hairpin cotter and pin to change hole location (Fig. 7).
3. Select a hole position so the gage wheel is 3/8" (9.5 mm) off the ground for the height-of-cut to be used (Fig. 7).
4. Insert pin and secure with hairpin cotter.
5. Repeat adjustment on other gage wheels.

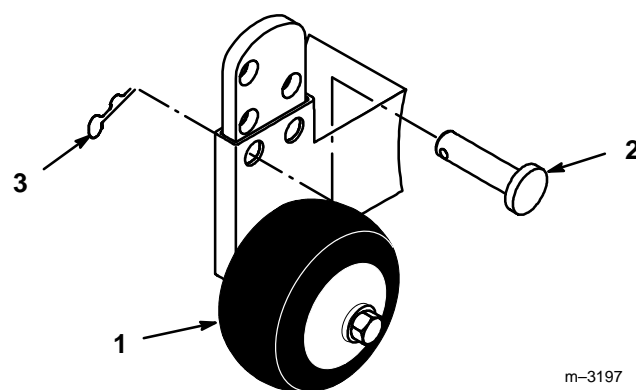

Figure 7

1. Wheel
2. Pin
3. Hair pin cotter

Maintenance

Service Interval Chart

Service Operation	Each Use	8 Hours	25 Hours	50 Hours	Notes
Cutting blades – check		X		X	
Belts – check for wear/cracks			X		
Blade spindle bearings – grease		X			
Idler arm – oil			X		
Castor wheels – grease			X		
Gearbox – check level of lubricant				X	
Mower housing – clean	X	X		X	
Chipped surfaces – paint				X	

Cutting Blades

To ensure a superior quality of cut, keep the blades sharp. For convenient sharpening and replacement, you may want to keep extra blades on hand.

WARNING

POTENTIAL HAZARD

- A blade that is worn or damaged could break apart and pieces could be thrown at bystanders or at you as you use the mower.

WHAT CAN HAPPEN

- Pieces of blade that may be thrown could seriously injure or kill you or bystanders.

HOW TO AVOID THE HAZARD

- Periodically inspect the blade for wear and damage. Immediately install a new blade if it is worn or damaged.

Before Inspecting or Servicing the Blades

Park the machine on a level surface, disengage the blade control (PTO) and set the parking brake. Turn the ignition key to “OFF” to stop the engine. Remove the key and disconnect the spark plug wire(s) from the spark plug(s).

Inspecting the Blades

1. Inspect the cutting edges (Fig 8). If the edges are not sharp or have nicks, remove and sharpen the blades. Refer to Sharpening the Blades on page 10.
2. Inspect the blades, especially the curved area (Fig. 8). If you notice any damage, wear, or a slot forming in this area (item 3 in Fig. 8), immediately install a new blade.

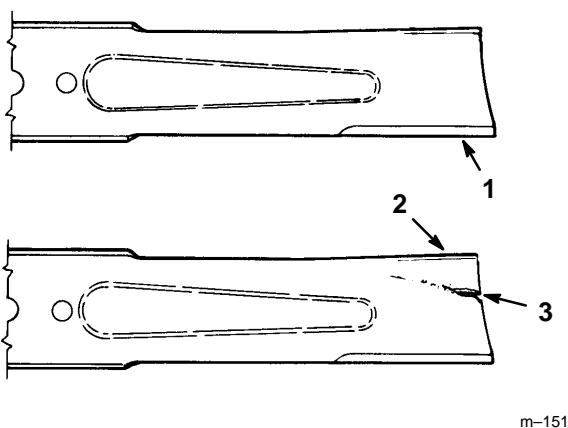

Figure 8

1. Cutting edge
2. Curved area
3. Wear/slot forming

Checking for Bent Blades

1. Rotate the blades until the ends face forward and backward (Fig. 9). Measure from a level surface to the cutting edge of the blades (Fig. 10). Note this dimension.

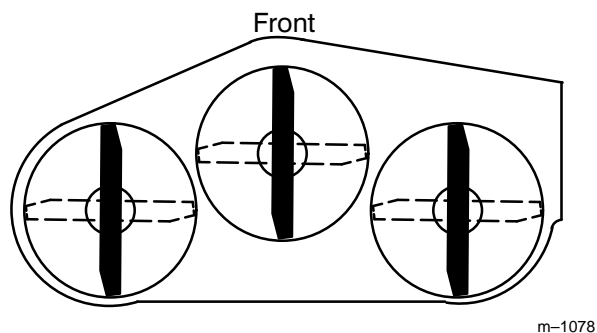
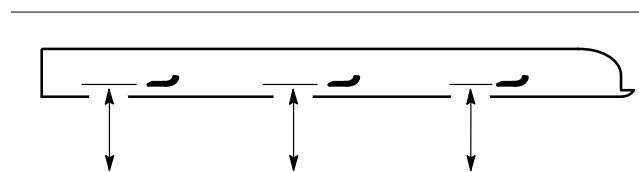

Figure 9



MEASURE FROM
CUTTING EDGE TO A
LEVEL SURFACE

Figure 10

2. Rotate the opposite ends of the blades forward. Measure from a level surface to the cutting edge of the blades at the same position as in step 1 above. The difference between the dimensions obtained in steps 1 and 2 must not exceed 1/8" (3 mm). If this dimension exceeds 1/8" (3 mm), the blade is bent and must be replaced. Refer to Removing the Blades, and Installing the Blades on page 10.

! WARNING

POTENTIAL HAZARD

- A blade that is bent or damaged could break apart and pieces could be thrown at bystanders or at you as you use the mower.

WHAT CAN HAPPEN

- Pieces of blade that may be thrown could seriously injure or kill you or bystanders.

HOW TO AVOID THE HAZARD

- Always replace bent or damaged blade with a new blade.
- Never file or create sharp notches in the edges or surfaces of blade.

Removing the Blades

Blades must be replaced if a solid object is hit, if the blade is out of balance or is bent. To ensure optimum performance and continued safety conformance of the machine, use genuine TORO replacement blades. Replacement blades made by other manufacturers may result in non-conformance with safety standards.

Hold the blade end using a rag or thickly-padded glove. Remove the blade bolt, washer, anti-scalp cup and blade from the spindle shaft (Fig. 11).

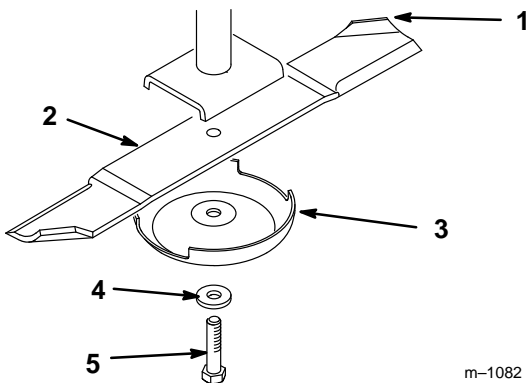

Figure 11

- | | |
|-----------------------|---------------|
| 1. Sail area of blade | 4. Washer |
| 2. Blade | 5. Blade bolt |
| 3. Anti-scalp cup | |

Sharpening the Blades

1. Use a file to sharpen the cutting edge at both ends of the blade (Fig. 12). Maintain the original angle. The blade retains its balance if the same amount of material is removed from both cutting edges.

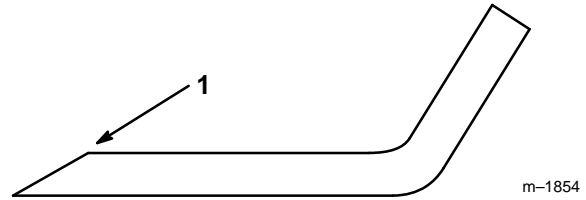

Figure 12

1. Sharpen at original angle

2. Check the balance of the blade by putting it on a blade balancer (Fig. 13). If the blade stays in a horizontal position, the blade is balanced and can be used. If the blade is not balanced, file some metal off the end of the sail area only (Fig. 11). Repeat this procedure until the blade is balanced.

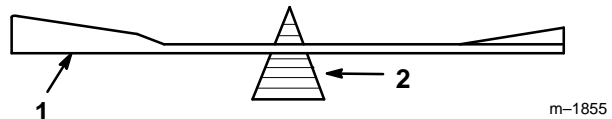

Figure 13

1. Blade
2. Balancer

Installing the Blades

1. Install the blade onto the spindle shaft (Fig. 11).

IMPORTANT: The curved part of the blade must be pointing upward toward the inside of the mower to ensure proper cutting.

2. Install the lock washer and blade bolt (Fig. 11). Torque the blade bolt to 85–110 ft-lb (115–140 N•m).

Correcting Cutting Unit Mismatch

If one cutter blade cuts lower than the other, correct as follows:

1. Stop the engine, remove the key and disconnect the spark plug wire(s) from the spark plug(s).
2. Adjust the tire pressure in all tires to specifications and check that the blades are not bent. Refer to Checking for Bent Blades on page 9.
3. Set the height-of-cut to the 2-1/2" position. Refer to Adjusting the Height-Of-Cut in the Operation section. Make sure the clevis pins are resting on the frame cushions.
4. Rotate the blades so the tips line up with one another. The blade tips must be within 1/8" (3 mm) of each other. If the blade tips are not within 1/8" (3 mm) of each other, add shims (Part No. 3256-24) between the appropriate spindle housing and the bottom of the cutting unit to align the blades.

Setting the Front-to-Rear Pitch

1. Check the tire pressure.
2. Position the blades front-to-rear (Fig. 14). Measure at "C" and "D" locations (Fig. 14) from a level surface to the cutting edge of the blades (Fig. 15).
3. The mower should be 1/8"–5/8" (3–16 mm) lower in front "C" than in the rear "D".

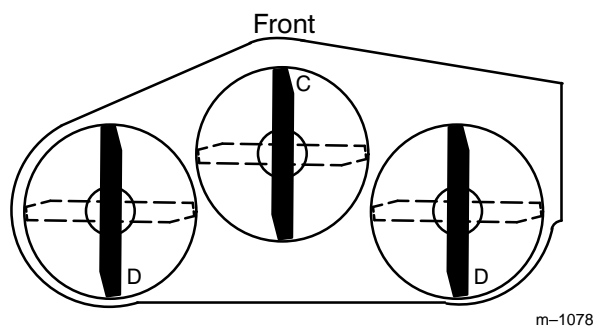
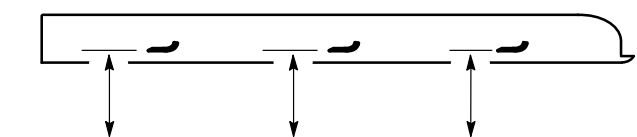

Figure 14



MEASURE FROM
CUTTING EDGE TO A
LEVEL SURFACE

Figure 15

4. To change the front-to-rear pitch, move an equal number of thrust washers on both castor wheel forks. Move the thrust washers from the top of the carrier frame mounting tube to the bottom to raise the front of the mower. Move the thrust washers from the bottom of the mounting tube to the top to lower the front of the mower. (Fig. 16).
5. Check the side-to-side leveling of the cutting unit.

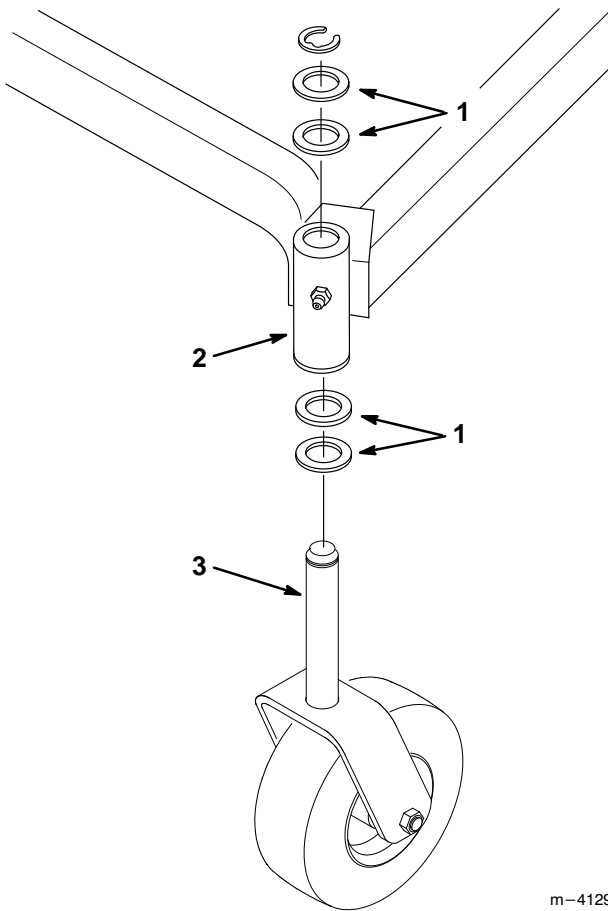

Figure 16

- | | |
|--|----------------------|
| 1. Thrust washers (locate as required) | 3. Castor wheel fork |
| 2. Carrier frame mounting tube | |

Setting the Side-to-Side Leveling

1. Check the tire pressure.
2. Position the blades side-to-side (Fig. 17). Measure at “A” and “B” locations (Fig. 17) from a level surface to the cutting edge of blades (Fig. 18).
3. The difference between measurements “A” and “B” should be no more than 1/4” (6 mm).

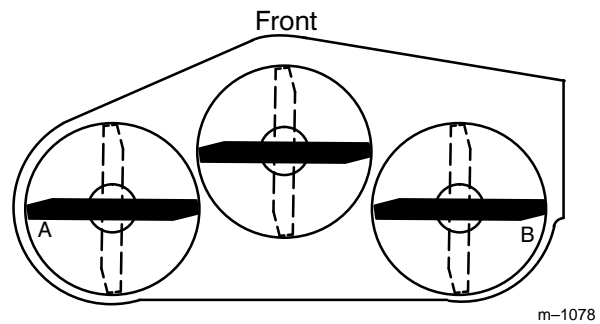
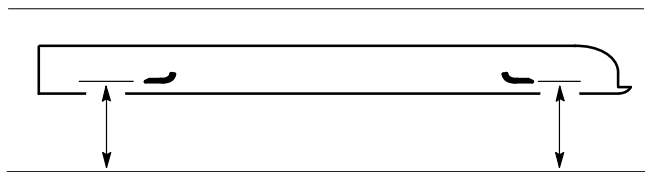

Figure 17



MEASURE FROM CUTTING EDGE TO A LEVEL SURFACE

Figure 18

4. To change the side-to-side leveling, move the thrust washers on one castor wheel fork only. Move the thrust washers from the top of the carrier frame mounting tube to the bottom to raise the corresponding side of the mower. Move the thrust washers from the bottom of the mounting tube to the top to lower the corresponding side of the mower. (Fig. 16).
5. Recheck the front-to-rear pitch of the cutting unit.

Greasing and Lubrication

Greasing

The cutting unit must be lubricated regularly. Refer to the Service Interval Chart on page 8. Grease with No. 2 general purpose lithium base or molybdenum base grease.

1. Stop the engine, remove the key and disconnect the spark plug wire(s) from the spark plug(s).
2. Grease the fittings on the three spindle bearings and the idler arm (Fig. 23).

Note: You'll have to remove the mower cover to access the grease fitting on the idler arm.

3. Grease the fittings on the carrier frame mounting tubes and castor wheels (Fig. 19).

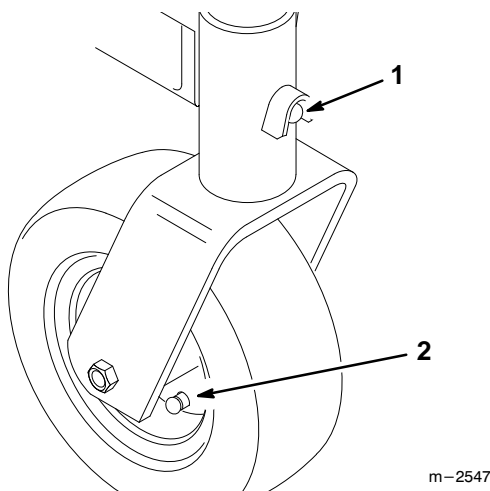

m-2547

Figure 19

1. Carrier frame mounting tube grease fitting
2. Castor wheel grease fitting

Lubrication

The gearbox lubrication should be checked regularly. Refer to the Service Interval Chart on page 8. Fill with SAE EP 90 gear lube.

4. Lower lift and adjust mower so it is level, all height-of-cut pins in the same hole.
5. Clean area around the gearbox so dirt does not get into gearbox.
6. Remove filler plug and check fluid level. Fluid should be at lower level of filler plug hole (Fig. 20).

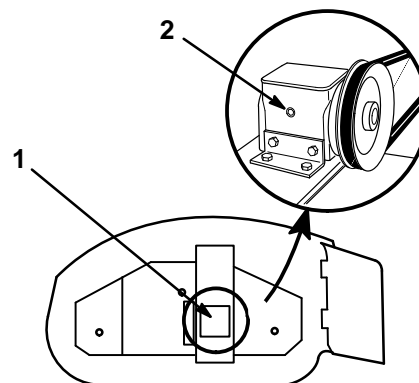

m-3161

Figure 20

1. Gearbox
2. Filler plug

7. Oil the mower idler arm pivot every 25 hours with a few drops of SAE 30 oil (Fig. 21).

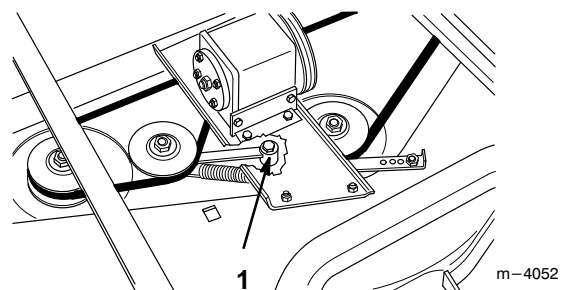

m-4052

Figure 21

1. Idler arm pivot

Replacing the Mower Belt

Squealing when the belt is rotating, blades slipping when cutting grass, frayed belt edges, burn marks and cracks are signs of a worn mower belt. Replace the mower belt if any of these conditions are evident.

1. Stop the engine, remove the key and disconnect the spark plug wire(s) from the spark plug(s).
2. Release the latches holding the mower cover to the top of the cutting unit and remove the mower cover (Fig. 22).

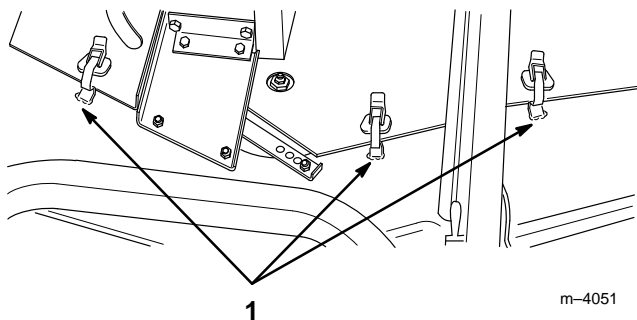

Figure 22

1. Latch

3. Remove nut securing spring anchor to housing and lift spring anchor from bolt (Fig. 23).
4. Remove the worn mower belt (Fig. 23).
5. Install new mower belt around the three spindle pulleys, the idler pulley, and the gearbox pulley (Fig. 23).
6. Pull on the spring anchor and connect to anchor bolt (Fig. 23).
7. Correct belt tension is achieved with 30-40 lb. of spring force applied to the spring. Change mounting hole location to increase tension.

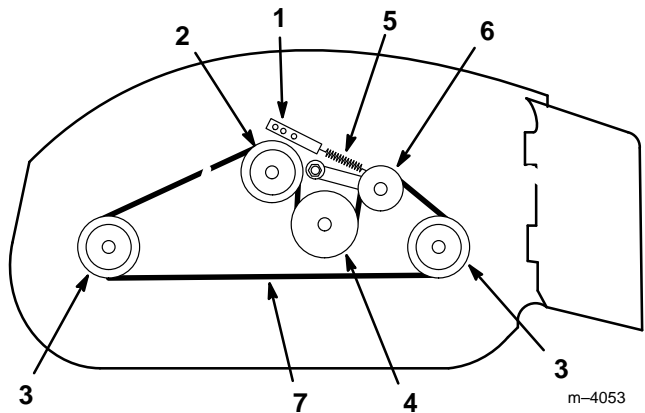

Figure 23

Top View

- | | |
|----------------------------|---------------------|
| 1. Idler arm anchor | 5. Idler arm spring |
| 2. Center spindle pulley | 6. Idler pulley |
| 3. Outboard spindle pulley | 7. Mower belt |
| 4. Gearbox pulley | |

8. Install covers onto the mower and secure latches (Fig. 22).

Replacing the Drive Belt

Squealing when the belt is rotating, blades slipping when cutting grass, frayed belt edges, burn marks and cracks are signs of a worn drive belt. Replace the drive belt if any of these conditions are evident.

1. Stop the engine, remove the key and disconnect the spark plug wire(s) from the spark plug(s).
2. Release latches holding the covers to the top of the mower, over gearbox pulley, and remove.
3. Install the new drive belt around the jackshaft pulley, on the traction unit, and the gearbox pulley on the mower (Fig. 24).
4. Raise the idler pulley and position over the upper portion of the drive belt (Fig. 24).
5. Install mower covers and secure latches.

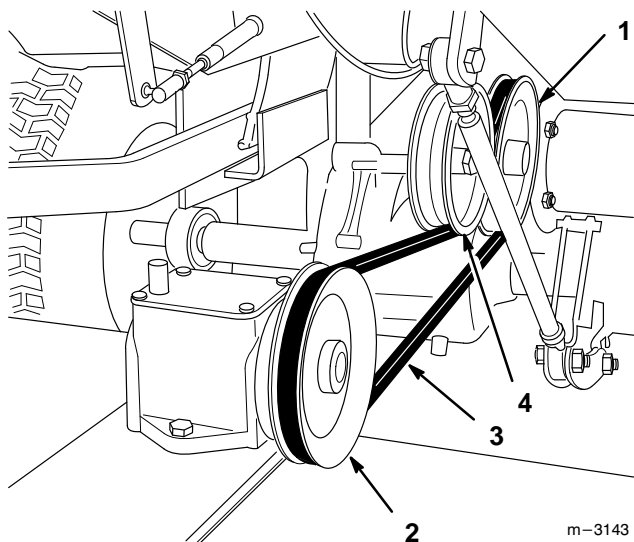

Figure 24

- | | |
|---------------------|-----------------|
| 1. Jackshaft pulley | 3. Drive belt |
| 2. Gearbox pulley | 4. Idler pulley |

Replacing the Grass Deflector

1. Remove the locknuts, bolts and springs holding the deflector mounts to the pivot brackets (Fig. 25).
2. If the pivot brackets need to be replaced, remove the carriage bolts and cone locknuts holding the old brackets to the top of the discharge opening, then install the replacement pivot brackets. Make sure the carriage bolt heads are on the inside of the cutting unit (Fig. 25).
3. Install the deflector mounts onto the pivot brackets with the bolts, springs and locknuts. Make sure the straight ends of the springs are positioned between the deflector mounts and the grass deflector (Fig. 25).
4. Tighten the locknuts until they contact the pivot brackets (Fig. 25).

IMPORTANT: The grass deflector must be spring-loaded in the down position. Lift the deflector up to test that it snaps to the full down position.

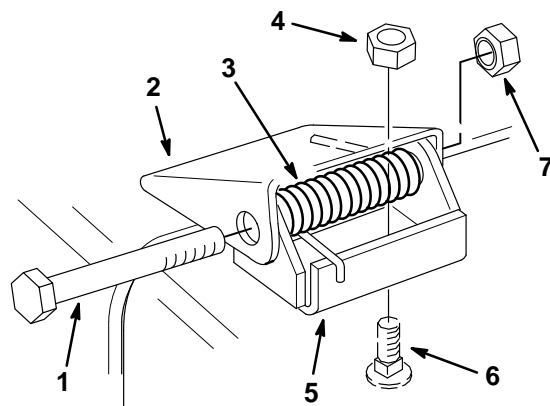

Figure 25

- | | |
|--------------------|------------------|
| 1. Bolt | 5. Pivot bracket |
| 2. Deflector mount | 6. Carriage bolt |
| 3. Spring | 7. Locknut |
| 4. Cone locknut | |

Replacing the Castor Wheel Fork Bushings

The castor wheel forks are mounted in bushings pressed into the top and bottom of the carrier frame mounting tubes. To check the bushings, move the castor forks back and forth and side-to-side. If a castor fork is loose, the bushings are worn and must be replaced.

1. Raise the cutting unit so the castor wheels are off the floor, then block up the front of the mower with jack stands.
2. Remove the retaining ring and thrust washer(s) from the top of the castor wheel fork (Fig. 26).
3. Pull the castor wheel fork out of the mounting tube, leaving the thrust washer(s) on the bottom of the fork. Remember the location of the thrust washers and spacer on each fork to ensure correct installation, and to maintain a level mower.

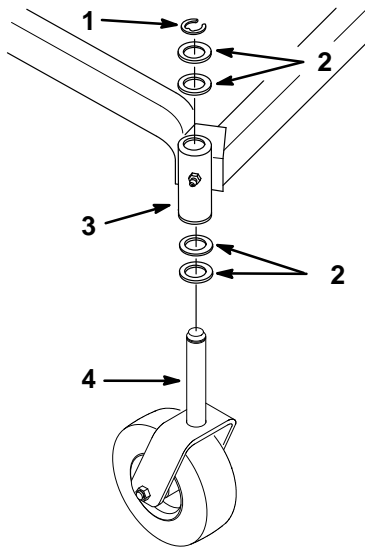

Figure 26

- | | |
|--|--------------------------------|
| 1. Retaining ring | 3. Carrier frame mounting tube |
| 2. Thrust washers (locate as required) | 4. Castor wheel fork |

m-3983

4. Insert a pin punch into the mounting tube and carefully drive out the bushings (Fig. 27). Clean the inside of the mounting tube.
 5. Grease the inside and outside of the new bushings. Use a hammer and flat plate to carefully drive the bushings into the mounting tube.
 6. Inspect the castor wheel fork for wear and replace if necessary (Fig. 26).
 7. Slide the castor wheel fork through the bushings in the mounting tube. Replace the thrust washer(s) onto the fork and secure with the retaining ring (Fig 26).
- IMPORTANT: The inside diameter of the bushings may collapse slightly when installed. If the castor wheel fork does not slide into the new bushings, ream both bushings to an inside diameter of 1.126 in. (28.6mm).**
8. Grease the fitting on the carrier frame mounting tube using No. 2 general purpose lithium base or molybdenum base grease.

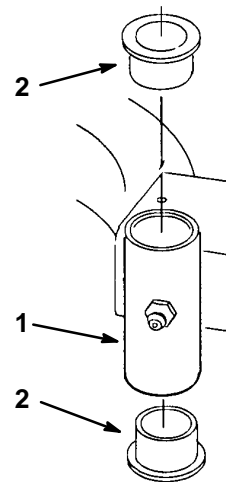

Figure 27

- | | |
|--------------------------------|------------|
| 1. Carrier frame mounting tube | 2. Bushing |
|--------------------------------|------------|

m-1076

Servicing the Castor Wheels and Bearings

The castor wheels rotate on a roller bearing supported by a spanner bushing. If the bearing is kept well lubricated, wear will be minimal. Failure to keep the bearing well lubricated will cause rapid wear. A wobbly castor wheel usually indicates a worn bearing.

1. Remove the locknut and wheel bolt holding the castor wheel to the castor fork (Fig. 28).
2. Remove the washers and bushing, then pull the spanner bushing and roller bearing out of the wheel hub (Fig. 28).
3. Remove the other bushing from the wheel hub and clean any grease and dirt from the wheel hub (Fig. 28).
4. Inspect the roller bearing, bushings, spanner bushing and inside of the wheel hub for wear. Replace any defective or worn parts (Fig. 28).

5. To assemble, place one (1) bushing into the wheel hub. Grease the roller bearing and spanner bushing and slide them into the wheel hub. Place the second bushing into the wheel hub (Fig. 28).
6. Install wheel bolt, (2) washers per side, and castor wheel into the castor fork. Secure with locknut and tighten until the spanner bushing bottoms against the inside of the castor forks (Fig. 28).
7. Grease the fitting on the castor wheel.

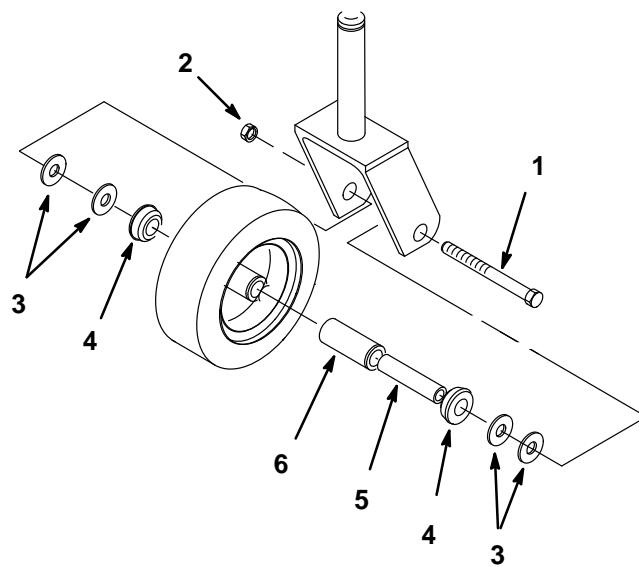

m-3896

Figure 28

- | | |
|---------------|--------------------|
| 1. Locknut | 4. Bushing |
| 2. Wheel bolt | 5. Spanner bushing |
| 3. Washer (4) | 6. Roller bearing |

Storage

1. Clean any dirt and chaff from the top of the mower.
2. Scrape any heavy buildup of grass and dirt from the underside of the mower, then wash the mower with a garden hose.
3. Check the condition of the blades. Refer to Cutting Blades on page 8.
4. Check the condition of the drive and mower belts.
5. Check and tighten all bolts, nuts and screws. Repair or replace any part that is damaged or defective.
6. Paint all scratched or bare metal surfaces. Paint is available from your Authorized Service Dealer.
7. Store the machine in a clean, dry garage or storage area. Cover the machine to protect it and keep it clean.

Troubleshooting

PROBLEM	POSSIBLE CAUSES	CORRECTIVE ACTION
Abnormal vibration.	<ol style="list-style-type: none"> 1. Cutting blade(s) is/are bent or unbalanced. 2. Blade mounting bolt is loose. 3. Gearbox mounting bolts are loose. 4. Loose gearbox pulley, idler pulley, or blade pulley. 5. Gearbox pulley is damaged. 6. Blade spindle bent. 	<ol style="list-style-type: none"> 1. Install new cutting blade(s). 2. Tighten blade mounting bolt. 3. Tighten gearbox mounting bolts. 4. Tighten the appropriate pulley. 5. Contact Authorized Service Dealer. 6. Contact Authorized Service Dealer.
Uneven cutting height.	<ol style="list-style-type: none"> 1. Blade(s) not sharp. 2. Cutting blade(s) is/are bent. 3. Mower is not level. 4. Underside of mower is dirty. 5. Tire pressure is incorrect. 6. Blade spindle bent. 	<ol style="list-style-type: none"> 1. Sharpen blade(s). 2. Install new cutting blade(s). 3. Level mower from side-to-side and front-to-rear. 4. Clean the underside of the mower. 5. Adjust tire pressure. 6. Contact Authorized Service Dealer.
Blades do not rotate.	<ol style="list-style-type: none"> 1. Drive belt is worn, loose or broken. 2. Drive belt is off pulley. 3. Deck belt is worn, loose or broken. 4. Deck belt is off pulley. 	<ol style="list-style-type: none"> 1. Install new drive belt. 2. Install drive belt and check adjusting shafts and belt guides for correct position. 3. Install new deck belt. 4. Install deck pulley and check the idler pulley, idler arm and spring for correct position and function.

