



**Count on it.**

**Operator's Manual**

**Z Master® Professional 6000  
Series Riding Mower  
with 60in or 72in TURBO FORCE® Side  
Discharge Mower**

Model No. 74946—Serial No. 402000000 and Up

Model No. 74947—Serial No. 402000000 and Up

Model No. 74969—Serial No. 400000000 and Up



It is a violation of California Public Resource Code Section 4442 or 4443 to use or operate the engine on any forest-covered, brush-covered, or grass-covered land unless the engine is equipped with a spark arrester, as defined in Section 4442, maintained in effective working order or the engine is constructed, equipped, and maintained for the prevention of fire.

**Gross or Net Torque:** The gross or net torque of this engine was laboratory rated by the engine manufacturer in accordance with the Society of Automotive Engineers (SAE) J1940 or J2723. As configured to meet safety, emission, and operating requirements, the actual engine torque on this class of mower will be significantly lower. Please refer to the engine manufacturer's information included with the machine.

## ▲ WARNING

### CALIFORNIA Proposition 65 Warning

The engine exhaust from this product contains chemicals known to the State of California to cause cancer, birth defects, or other reproductive harm.

Battery posts, terminals, and related accessories contain lead and lead compounds, chemicals known to the State of California to cause cancer and reproductive harm. Wash hands after handling.

Use of this product may cause exposure to chemicals known to the State of California to cause cancer, birth defects, or other reproductive harm.

# Introduction

This rotary-blade, riding lawn mower is intended to be used by professional, hired operators. It is designed primarily for cutting grass on well-maintained lawns on residential or commercial properties. It is not designed for cutting brush or for agricultural uses.

Read this information carefully to learn how to operate and maintain your product properly and to avoid injury and product damage. You are responsible for operating the product properly and safely.

You may contact Toro directly at [www.Toro.com](http://www.Toro.com) for product safety and operation training materials, accessory information, help finding a dealer, or to register your product.

For the Operator's Manual, the complete warranty details, or to register your product, use the QR code or visit [www.Toro.com](http://www.Toro.com). You may also call us at 1-888-384-9939 to request a written copy of the product warranty.

Whenever you need service, genuine Toro parts, or additional information, contact an Authorized Service Dealer or Toro Customer Service and have the model and serial numbers of your product ready. [Figure 1](#) identifies the location of the model and serial numbers on the product. Write the numbers in the space provided.

**Important:** With your mobile device, you can scan the QR code (if equipped) on the serial number decal to access warranty, parts, and other product information.

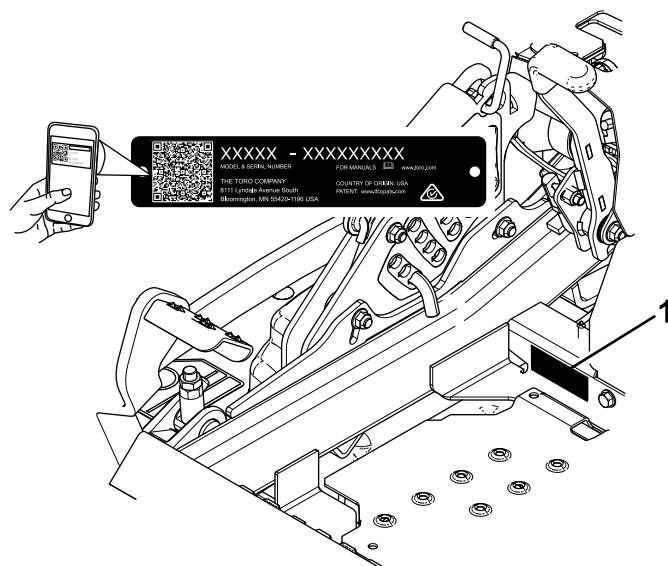

Figure 1

1. Model and serial number location

g233771

Model No. \_\_\_\_\_

Serial No. \_\_\_\_\_

# Contents

- Safety ..... 4
  - General Safety ..... 4
  - Slope Indicator ..... 5
  - Safety and Instructional Decals ..... 6
- Product Overview ..... 12
  - Controls ..... 12
  - Specifications ..... 13
- Before Operation ..... 14
  - Before Operation Safety ..... 14
  - Adding Fuel ..... 14
  - Performing Daily Maintenance ..... 15
  - Breaking in a New Machine ..... 15
  - Using the Rollover-Protection System (ROPS) ..... 16
  - Using the Safety-Interlock System ..... 17
  - Positioning the Seat ..... 18
  - Unlatching the Seat ..... 18
  - Changing the Seat Suspension ..... 18
- During Operation ..... 19
  - During Operation Safety ..... 19
  - Operating the Parking Brake ..... 20
  - Operating the Mower Blade-Control Switch (PTO) ..... 21
  - Starting the Engine ..... 21
  - Shutting Off the Engine ..... 22
  - Using the Motion-Control Levers ..... 22
  - Driving the Machine ..... 22
  - Using the Side Discharge ..... 24
  - Adjusting the Height of Cut ..... 24
  - Adjusting the Anti-Scalp Rollers ..... 25
  - Adjusting the Flow Baffle Cam Locks ..... 26
  - Positioning the Flow Baffle ..... 26
  - Operating Tips ..... 27
- After Operation ..... 28
  - After Operation Safety ..... 28
  - Using the Fuel-Shutoff Valve ..... 28
  - Using the Drive-Wheel-Release Valves ..... 28
  - Transporting the Machine ..... 29
- Maintenance ..... 31
  - Recommended Maintenance Schedule(s) ..... 31
  - Pre-Maintenance Procedures ..... 32
    - Maintenance Safety ..... 32
  - Lubrication ..... 33
    - Greasing the Machine ..... 33
    - Adding Light Oil or Spray Lubrication ..... 33
    - Greasing the Mower Deck ..... 34
    - Lubricating the Caster-Wheel Hubs ..... 35
  - Engine Maintenance ..... 36
    - Identifying the Engine ..... 36
    - Engine Safety ..... 36
    - Servicing a Kawasaki® Engine ..... 36
    - Servicing a Kohler® Engine ..... 42
    - Checking the Spark Arrester ..... 46
  - Fuel System Maintenance ..... 47
    - Servicing the Electronic Fuel-Injection System ..... 47

This manual identifies potential hazards and has safety messages identified by the safety-alert symbol (Figure 2), which signals a hazard that may cause serious injury or death if you do not follow the recommended precautions.



**Figure 2**  
Safety-alert symbol

g000502

This manual uses 2 words to highlight information. **Important** calls attention to special mechanical information and **Note** emphasizes general information worthy of special attention.

# Safety

This machine has been designed in accordance with ANSI B71.4-2012.

## General Safety

This product is capable of amputating hands and feet and of throwing objects. Always follow all safety instructions to avoid serious personal injury.

Using this product for purposes other than its intended use could prove dangerous to you and bystanders.

- Always keep the roll bar in the fully raised and locked position and use the seat belt.
- Do not operate the machine near drop-offs, ditches, embankments, water, or other hazards, or on slopes greater than 15 degrees.
- Read and understand the contents of this *Operator's Manual* before starting the engine.
- Do not put your hands or feet near moving components of the machine.
- Do not operate the machine without all guards and other safety protective devices in place and working on the machine.
- Keep children and bystanders out of the operating area. Never allow children to operate the machine.
- Stop the machine, shut off the engine, and remove the key before servicing, fueling, or unclogging the machine.

Improperly using or maintaining this machine can result in injury. To reduce the potential for injury, comply with these safety instructions and always pay attention to the safety-alert symbol, which means Caution, Warning, or Danger—personal safety instruction. Failure to comply with these instructions may result in personal injury or death.

You can find additional safety information where needed throughout this manual.

|  |    |
|--|----|
| Replacing the Low-Pressure Fuel Filter.....            | 47 |
| Filter.....  | 47 |
| Servicing the High-Pressure Fuel Filter.....           | 47 |
| Servicing the Fuel Tank.....                           | 47 |
| Electrical System Maintenance .....                    | 48 |
| Electrical System Safety .....                         | 48 |
| Servicing the Battery.....                             | 48 |
| Servicing the Fuses .....                              | 50 |
| Drive System Maintenance .....                         | 50 |
| Checking the Seat Belt .....                           | 50 |
| Checking the Roll-Bar Knobs .....                      | 50 |
| Adjusting the Tracking .....                           | 51 |
| Checking the Tire Pressure.....                        | 52 |
| Checking the Wheel Lug Nuts.....                       | 52 |
| Checking the Wheel-Hub Slotted Nut.....                | 52 |
| Adjusting the Caster-Pivot Bearing .....               | 52 |
| Using the Clutch Shim .....                            | 53 |
| Cooling System Maintenance .....                       | 55 |
| Cleaning the Engine Screen and Engine-Oil Cooler ..... | 55 |
| Cleaning the Engine-Cooling Fins and Shrouds .....     | 55 |
| Checking and Cleaning the Hydraulic-Unit Shrouds ..... | 56 |
| Brake Maintenance .....                                | 56 |
| Adjusting the Parking Brake.....                       | 56 |
| Belt Maintenance .....                                 | 57 |
| Inspecting the Belts .....                             | 57 |
| Replacing the Mower Belt .....                         | 57 |
| Replacing the Hydraulic Pump-Drive Belt.....           | 58 |
| Controls System Maintenance .....                      | 59 |
| Adjusting the Control-Handle Position .....            | 59 |
| Adjusting the Motion-Control Linkage .....             | 60 |
| Adjusting the Motion-Control Damper .....              | 61 |
| Adjusting the Motion-Control Neutral-Lock Pivot.....   | 61 |
| Hydraulic System Maintenance .....                     | 62 |
| Hydraulic System Safety.....                           | 62 |
| Servicing the Hydraulic System .....                   | 62 |
| Mower Deck Maintenance.....                            | 64 |
| Leveling the Mower Deck.....                           | 64 |
| Servicing the Cutting Blades .....                     | 66 |
| Removing the Mower Deck.....                           | 68 |
| Replacing the Grass Deflector .....                    | 69 |
| Cleaning .....   | 70 |
| Cleaning under the Mower Deck .....                    | 70 |
| Disposing of Waste.....                                | 70 |
| Storage .....  | 70 |
| Storage Safety.....                                    | 70 |
| Cleaning and Storage.....                              | 70 |
| Troubleshooting .....                                  | 72 |
| Schematics .....                                       | 75 |

# Slope Indicator

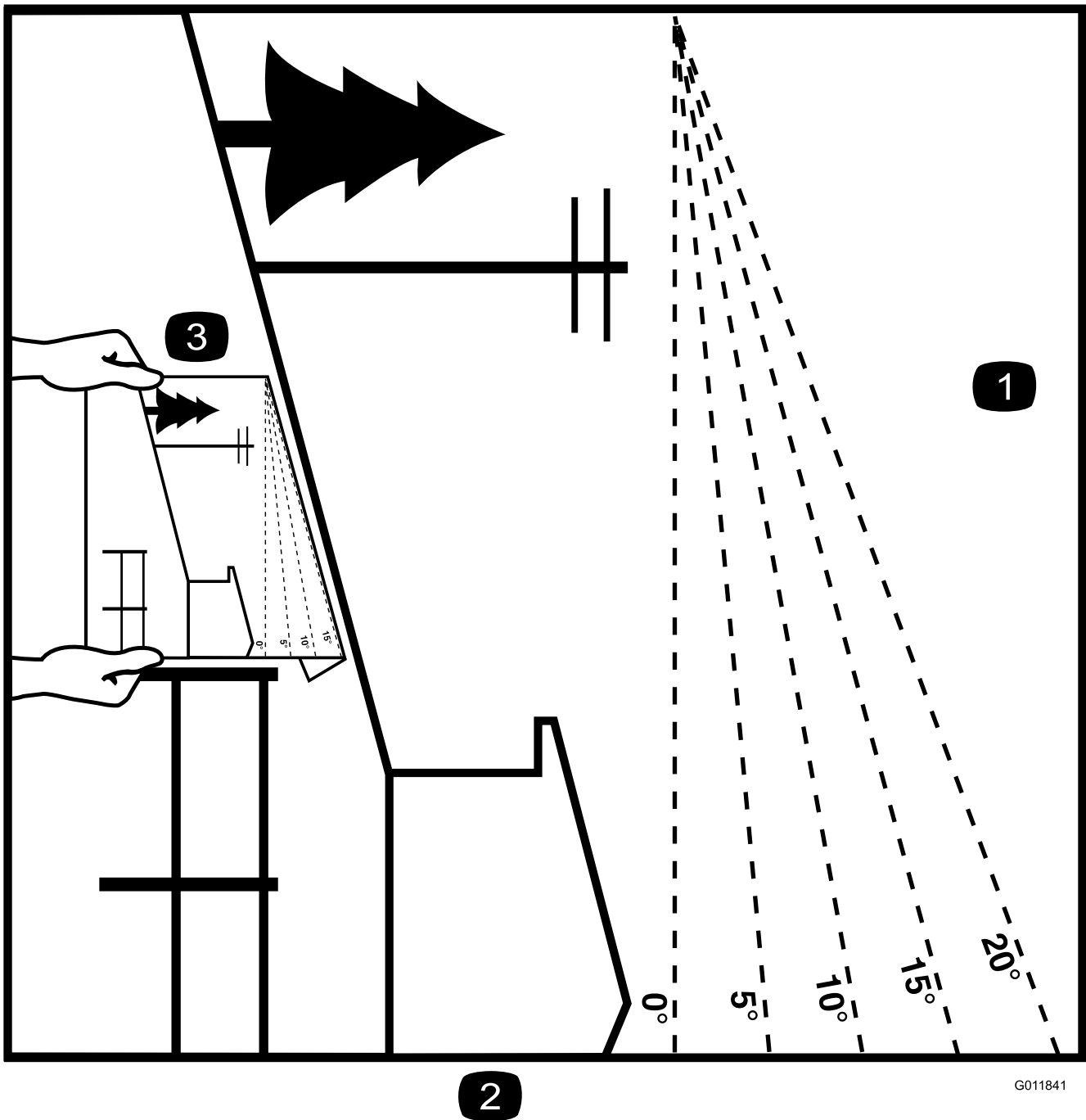

G011841

g011841

**Figure 3**

You may copy this page for personal use.

1. The maximum slope you can operate the machine on is **15 degrees**. Use the slope chart to determine the degree of slope of hills before operating. **Do not operate this machine on a slope greater than 15 degrees**. Fold along the appropriate line to match the recommended slope.
2. Align this edge with a vertical surface, a tree, building, fence pole, etc.
3. Example of how to compare slope with folded edge

# Safety and Instructional Decals



Safety decals and instructions are easily visible to the operator and are located near any area of potential danger. Replace any decal that is damaged or missing.



## Battery Symbols

Some or all of these symbols are on your battery

- |  |   |
|--|---|
| 1. Explosion hazard                    | 6. Keep bystanders a safe distance away from the battery.                       |
| 2. No fire, open flame, or smoking     | 7. Wear eye protection; explosive gases can cause blindness and other injuries. |
| 3. Caustic liquid/chemical burn hazard | 8. Battery acid can cause blindness or severe burns.                            |
| 4. Wear eye protection.                | 9. Flush eyes immediately with water and get medical help fast.                 |
| 5. Read the <i>Operator's Manual</i> . | 10. Contains lead; do not discard   |

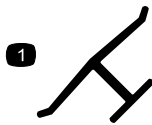

## Manufacturer's Mark

- Indicates the blade is identified as a part from the original machine manufacturer.



58-6520

- Grease

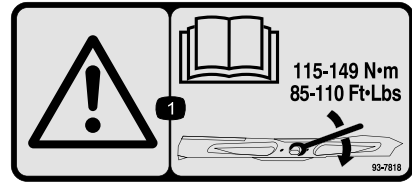

93-7818

- Warning—read the *Operator's Manual* for instructions on torquing the blade bolt/nut to 115 to 149 N·m (85 to 110 ft-lb).

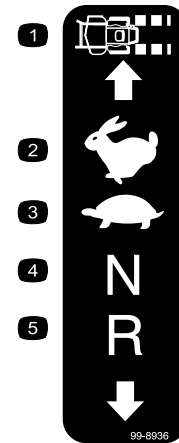

99-8936

- |                  |            |
|------------------|------------|
| 1. Machine speed | 4. Neutral |
| 2. Fast          | 5. Reverse |
| 3. Slow          |            |



106-2655

- Warning—do not touch or approach moving belts; remove the ignition key and read the instructions before servicing or performing maintenance.



106-5517

decal106-5517

1. Warning—do not touch the hot surface.



107-3069

decal107-3069

1. Warning—there is no rollover protection when the roll bar is down.
2. To avoid injury or death from a rollover accident, keep the roll bar in the raised and locked position and wear the seat belt. Lower the roll bar only when absolutely necessary; do not wear the seat belt when the roll bar is down.
3. Read the *Operator's Manual*; drive slowly and carefully.

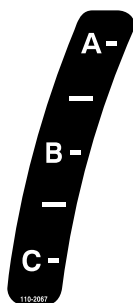

110-2067

decal110-2067

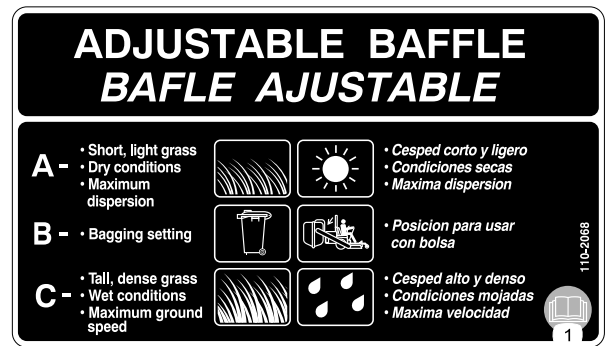

110-2068

decal110-2068

1. Read the *Operator's Manual*.

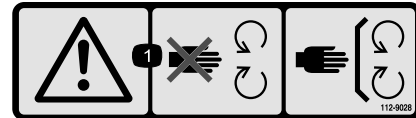

112-9028

decal112-9028

1. Warning—stay away from moving parts; keep all guards in place.

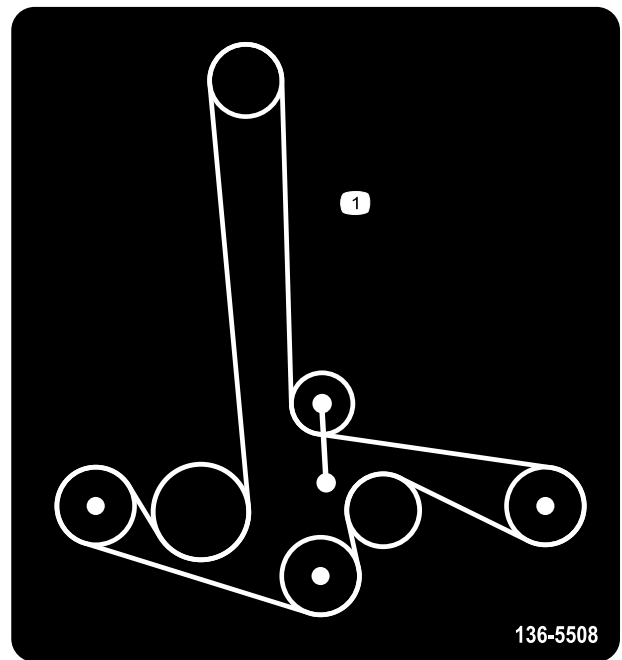

136-5508

decal136-5508

1. Belt routing

**CALIFORNIA SPARK ARRESTER WARNING**

Operation of this equipment may create sparks that can start fires around dry vegetation. A spark arrester may be required. The operator should contact local fire agencies for laws or regulations relating to fire prevention requirements.

116-4858

116-4858

decal116-4858

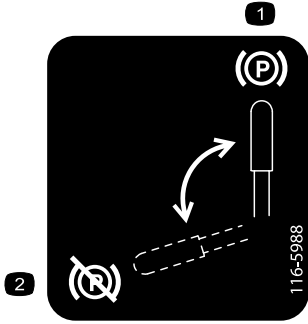

116-5988

decal116-5988

1. Parking brake—engaged
2. Parking brake—disengaged



116-8726

decal116-8726

1. Read the *Operator's Manual* for the recommended hydraulic fluid.

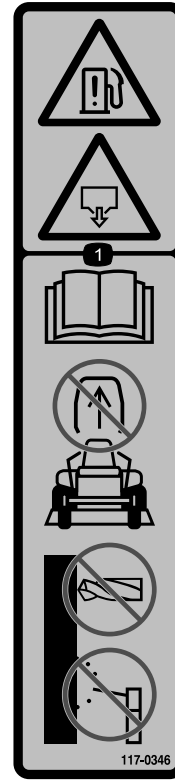

117-0346

decal117-0346

1. Fuel leak hazard—read the *Operator's Manual*; do not attempt to remove the roll bar; do not weld, drill, or modify the roll bar in any way.



117-3848

decal117-3848

1. Thrown object hazard—keep bystanders a safe distance away from the machine.
2. Thrown object hazard, mower—do not operate the machine without the deflector, discharge cover, or grass collection system in place.
3. Cutting/dismemberment of hand or foot—stay away from moving parts; keep all guards and shields in place.



119-6807

decal119-6807

1. Warning—no step

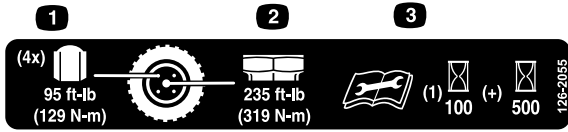

126-2055

decal126-2055

1. Wheel lug nut torque 95 ft-lb (129 N-m) (4x)
2. Wheel hub nut torque 235 ft-lb (319 N-m)
3. Read and understand the *Operator's Manual* before performing any maintenance, check torque after first 100 hours then every 500 hours thereafter.

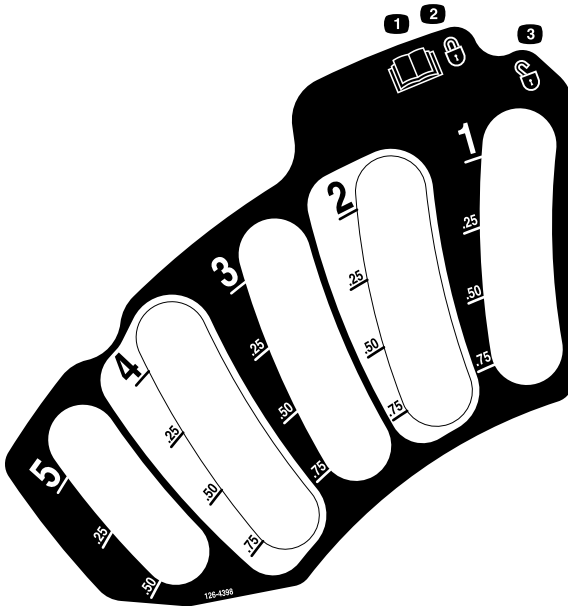

126-4398

decal126-4398

1. Read the *Operator's Manual*.
2. Lock
3. Unlock

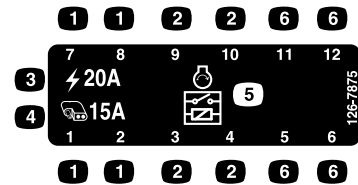

126-7875

decal126-7875

1. Fuse location
2. Relay location
3. Main, 20A
4. Auxiliary, 15A
5. Start relay
6. Not used

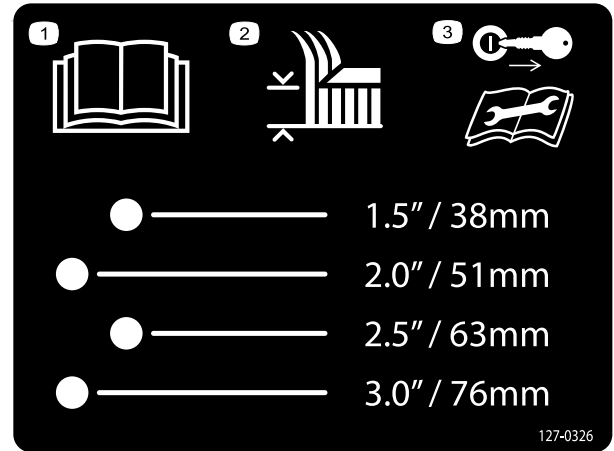

127-0326

decal127-0326

1. Read the *Operator's Manual*.
2. Height-of-cut
3. Remove the key from the ignition and read the *Operator's Manual* before performing maintenance or servicing the machine.

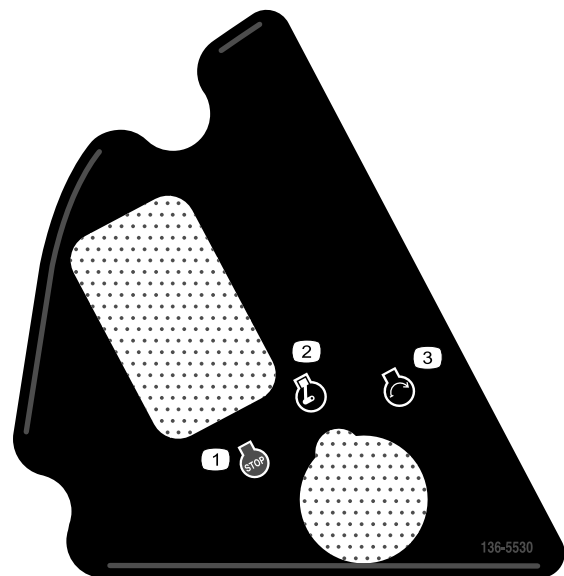

136-5530

decal136-5530

1. Engine—stop
2. Engine—run
3. Engine—start

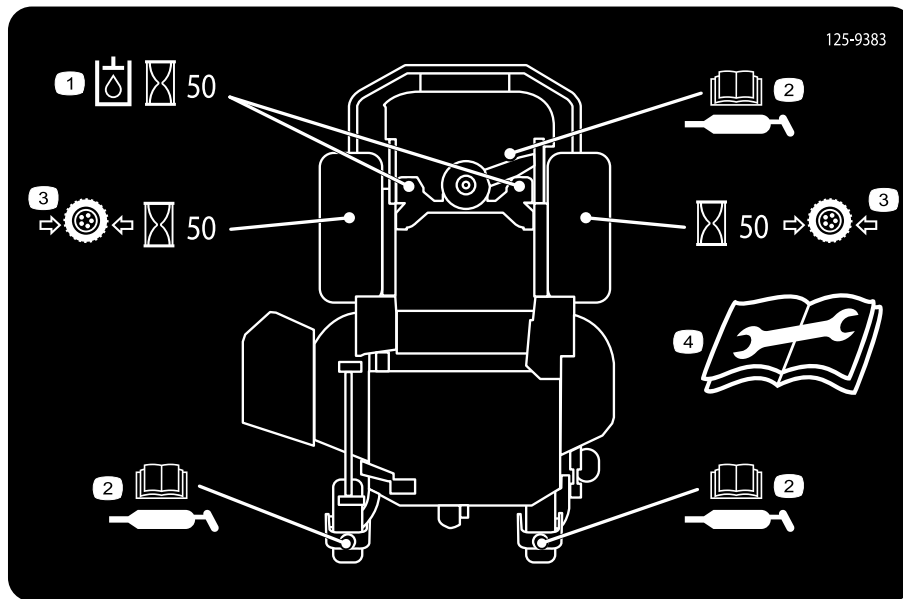

125-9383

**125-9383**

decal125-9383

1. Check the hydraulic fluid every 50 operating hours.
2. Read the *Operator's Manual* for information on lubricating the machine.
3. Check the tire pressure every 50 operating hours.
4. Read the *Operator's Manual* before servicing or performing maintenance.

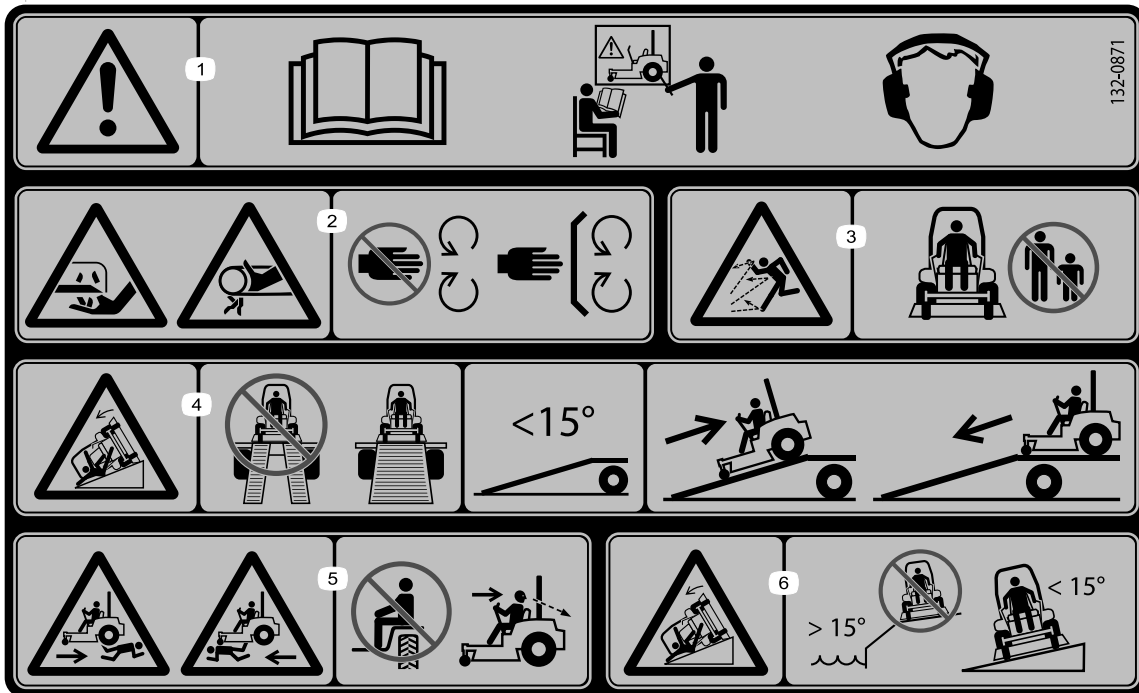

132-0871

decal132-0871

**Note:** This machine complies with the industry standard stability test in the static lateral and longitudinal tests with the maximum recommended slope indicated on the decal. Review the instructions for operating the machine on slopes in the *Operator's Manual* as well as the conditions in which you would operate the machine to determine whether you can operate the machine in those conditions on that day and at that site. Changes in the terrain can result in a change in slope operation for the machine. If possible, keep the cutting units lowered to the ground while operating the machine on slopes. Raising the cutting units while operating on slopes can cause the machine to become unstable.

1. Warning—read the *Operator's Manual*; do not operate this machine unless you are trained; wear hearing protection.
2. Cutting, dismembering, and entanglement hazard—keep hands away from moving parts; keep all guards and shields in place.
3. Thrown object hazard—keep bystanders away.
4. Ramp hazard—when loading onto a trailer, do not use dual ramps; only use a singular ramp wide enough for the machine and that has an incline less than  $15^\circ$ ; back up the ramp (in reverse) and drive forward off the ramp.
5. Bodily harm hazard—do not carry passengers; look behind you when mowing in reverse.
6. Tipping hazard on slopes—do not use on slopes near open water; do not use on slopes greater than  $15^\circ$ .

# Product Overview

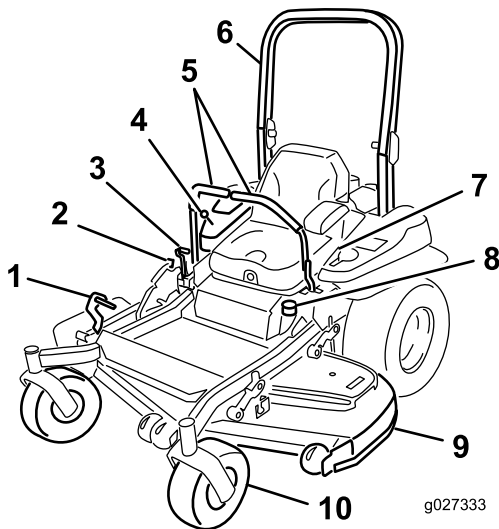

Figure 4

- |                                  |                  |
|----------------------------------|------------------|
| 1. Height-of-cut deck-lift pedal | 6. Roll bar      |
| 2. Transport lock                | 7. Seat belt     |
| 3. Parking-brake lever           | 8. Fuel cap      |
| 4. Controls                      | 9. Mower deck    |
| 5. Motion-control levers         | 10. Caster wheel |

## Controls

### Control Panel

Become familiar with all of the controls before you start the engine and operate the machine (Figure 4 and Figure 5).

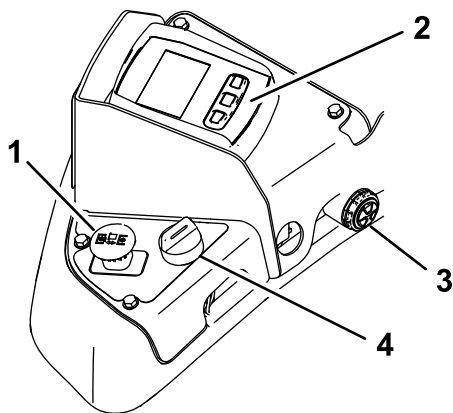

Figure 5

- |   |                  |
|---|------------------|
| 1. Blade-control switch (power takeoff) | 3. Audible alarm |
| 2. Horizon display monitor              | 4. Key switch    |

The Horizon Display Monitor monitors and displays machine system information.

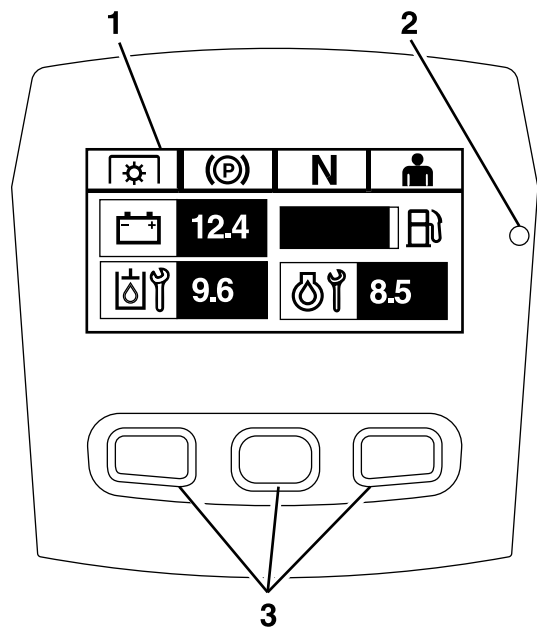

Figure 6

- |                       |                 |
|-----------------------|-----------------|
| 1. Information screen | 3. Push buttons |
| 2. LED status light   |                 |

## Horizon Display Monitor

Refer to the *Software Guide* for detailed information explaining the operator interface that allows users to access information, reset counters, modify system settings, and troubleshoot the equipment.

### Information Screen

The information screen displays information relative to machine operation; refer to the *Software Guide* for more information.

### Buttons

The icons displayed on the information screen above the buttons indicate the current function. The buttons allow the user to select the engine speed as well as navigate through system menus.

Refer to the *Software Guide* for more information.

### LED Status Light

The LED is multi-colored to indicate the system status. During start-up, the LED illuminates red, then orange, then green to verify functionality.

- **Solid green**—indicates normal operating activity
- **Blinking red**—indicates an active fault
- **Blinking green and orange**— indicates that a clutch reset is required

Refer to the *Software Guide* for more information.

## Audible Alarm

The audible alarm (Figure 5) sounds if an error occurs, indicating an issue to the operator. During start-up, the alarm sounds briefly to verify functionality.

When the alarm sounds, an error message displays on the monitor, and the LED turns red.

- Continuous sound indicates a critical error.
- Chirping sound indicates less critical errors, such as required maintenance or service intervals.

Refer to the *Software Guide* for more information.

## Hour Meter

The hour meter records the number of hours the engine has operated. It operates when the engine is running. Use these times for scheduling regular maintenance (Figure 5).

Hours are displayed in **Engine-Off** screen or in the **Engine Hour Counter** menu.

Refer to the *Software Guide* for more information.

## Throttle Control

The throttle controls the engine speed, and there are 3 speeds: Max, Efficient, and Low.

Refer to the *Software Guide* for more information.

## Blade-Control Switch (Power Takeoff)

The blade-control switch, represented by a power-takeoff (PTO) symbol, engages and disengages power to the mower blades (Figure 5).

## Safety-Interlock Indicators

There are symbols that display on the Horizon Display Monitor when the interlock component is positioned correctly (Figure 5).

## Key Switch

The key switch, used to start and shut off the engine, has 3 positions: OFF, RUN, and START. Refer to [Starting the Engine \(page 21\)](#).

## Motion-Control Levers

Use the motion-control levers to drive the machine forward, reverse, and turn either direction (Figure 4).

## Neutral-Lock Position

Use the NEUTRAL-LOCK position with the safety-interlock system to engage and to determine the NEUTRAL position.

## Fuel-Shutoff Valve

Close the fuel-shutoff valve when transporting or storing the machine; refer to [Using the Fuel-Shutoff Valve \(page 28\)](#).

## Attachments/Accessories

A selection of Toro approved attachments and accessories is available for use with the machine to enhance and expand its capabilities. Contact your Authorized Service Dealer or authorized Toro distributor or go to [www.Toro.com](http://www.Toro.com) for a list of all approved attachments and accessories.

To ensure optimum performance and continued safety certification of the machine, use only genuine Toro replacement parts and accessories. Replacement parts and accessories made by other manufacturers could be dangerous, and such use could void the product warranty.

## Specifications

**Note:** Specifications and design are subject to change without notice.

### Width:

|                | 60-inch Deck       | 72-inch Deck       |
|----------------|--------------------|--------------------|
| Without Deck   | 135 cm (53 inches) | 150 cm (59 inches) |
| Deflector Up   | 157 cm (62 inches) | 187 cm (74 inches) |
| Deflector Down | 192 cm (76 inches) | 222 cm (88 inches) |

### Length:

|                 | 60-inch Deck       | 72-inch Deck       |
|-----------------|--------------------|--------------------|
| Roll Bar - Up   | 211 cm (83 inches) | 219 cm (83 inches) |
| Roll Bar - Down | 215 cm (85 inches) | 223 cm (88 inches) |

### Height:

| Roll Bar - Up      | Roll Bar - Down    |
|--------------------|--------------------|
| 179 cm (71 inches) | 119 cm (47 inches) |

### Weight:

| Model | Weight            |
|-------|-------------------|
| 74946 | 576 kg (1,269 lb) |
| 74947 | 612 kg (1,349 lb) |
| 74969 | 576 kg (1,270 lb) |

# Operation

**Note:** Determine the left and right sides of the machine from the normal operating position.

## Before Operation

### Before Operation Safety

#### General Safety

- Never allow children or untrained people to operate or service the machine. Local regulations may restrict the age of the operator. The owner is responsible for training all operators and mechanics.
- Become familiar with the safe operation of the equipment, operator controls, and safety signs.
- Know how to stop the machine and shut off the engine quickly.
- Check that operator-presence controls, safety switches, and shields are attached and functioning properly. Do not operate the machine unless they are functioning properly.
- Before mowing, always inspect the machine to ensure that the blades, blade bolts, and cutting assemblies are in good working condition. Replace worn or damaged blades and bolts in sets to preserve balance.
- Inspect the area where you will use the machine and remove all objects that the machine could throw.
- Evaluate the terrain to determine the appropriate equipment and any attachments or accessories required to operate the machine properly and safely.

#### Fuel Safety

- To avoid personal injury or property damage, use extreme care in handling fuel. Fuel vapors are flammable and explosive.
- Extinguish all cigarettes, cigars, pipes, and other sources of ignition.
- Use only an approved fuel container.
- Do not remove the fuel cap or add fuel to the fuel tank while the engine is running or while hot.
- Do not refuel the machine indoors.
- Do not store the machine or fuel container where there is an open flame, spark, or pilot light, such as on a water heater or on other appliances.
- Do not fill containers inside a vehicle or on a truck or trailer bed with a plastic liner. Always place

containers on the ground, away from your vehicle before filling.

- Remove the equipment from the truck or trailer and refuel it while it is on the ground. If this is not possible, then refuel from a portable container rather than a fuel-dispenser nozzle.
- Do not operate the machine without the entire exhaust system in place and in proper working condition.
- Keep the fuel-dispenser nozzle in contact with the rim of the fuel tank or container opening at all times until fueling is complete. Do not use a nozzle lock-open device.
- If you spill fuel on your clothing, change your clothing immediately. Wipe up any fuel that spills.
- Never overfill the fuel tank. Replace the fuel cap and tighten it securely.
- Store fuel in an approved container and keep it out of the reach of children. Never buy more than a 30-day supply of fuel.
- Do not fill the fuel tank completely full. Add fuel to the fuel tank until the level is 6 to 13 mm (1/4 to 1/2 inch) below the bottom of the filler neck. This empty space in the tank allows fuel to expand.
  - Avoid prolonged breathing of vapors.
  - Keep your face away from the nozzle and fuel tank opening.
  - Avoid contact with skin; wash off spills with soap and water.

## Adding Fuel

### Recommended Fuel

- For best results, use only clean, fresh (less than 30 days old), unleaded gasoline with an octane rating of 87 or higher ((R+M)/2 rating method).
- **Ethanol:** Gasoline with up to 10% ethanol (gasohol) or 15% MTBE (methyl tertiary butyl ether) by volume is acceptable. Ethanol and MTBE are not the same. Gasoline with 15% ethanol (E15) by volume is not approved for use. **Never use gasoline that contains more than 10% ethanol by volume**, such as E15 (contains 15% ethanol), E20 (contains 20% ethanol), or E85 (contains up to 85% ethanol). Using unapproved gasoline may cause performance problems and/or engine damage which may not be covered under warranty.
- **Do not** use gasoline containing methanol.
- **Do not** store fuel either in the fuel tank or fuel containers over the winter unless you use a fuel stabilizer.
- **Do not** add oil to gasoline.

## Using Stabilizer/Conditioner

Use a fuel stabilizer/conditioner in the machine to provide the following benefits:

- Keeps fuel fresh longer when used as directed by the fuel-stabilizer manufacturer
- Cleans the engine while it runs
- Eliminates gum-like varnish buildup in the fuel system, which causes hard starting

**Important:** Do not use fuel additives containing methanol or ethanol.

Add the correct amount of fuel stabilizer/conditioner to the fuel.

**Note:** A fuel stabilizer/conditioner is most effective when mixed with fresh fuel. To minimize the chance of varnish deposits in the fuel system, use fuel stabilizer at all times.

## Filling the Fuel Tank

1. Park the machine on a level surface.
2. Engage the parking brake.
3. Shut off the engine and remove the key.
4. Clean around the fuel-tank cap.
5. Fill the fuel tank to the bottom of the filler neck (Figure 7).

**Note:** Do not fill the fuel tank completely full. The empty space in the tank allows the fuel to expand.

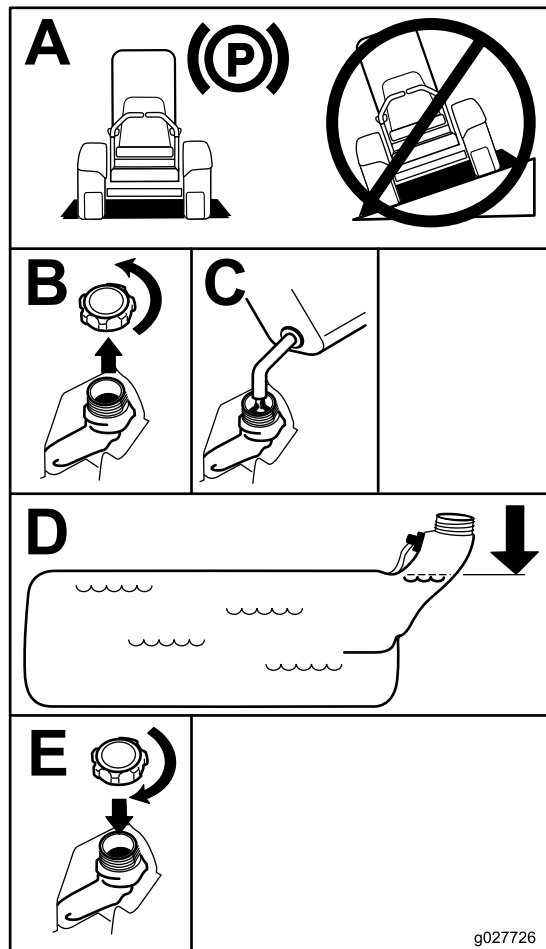

Figure 7

g027726

## Performing Daily Maintenance

Before starting the machine each day, perform the Each Use/Daily procedures listed in [Maintenance \(page 31\)](#).

## Breaking in a New Machine

New engines take time to develop full power. Mower decks and drive systems have higher friction when new, placing additional load on the engine. Allow 40 to 50 hours of break-in time for new machines to develop full power and best performance.

# Using the Rollover-Protection System (ROPS)

## ⚠ WARNING

To avoid injury or death from rollover, keep the roll bar in the fully raised, locked position and use the seat belt.

Ensure that the seat is secured to the machine.

## ⚠ WARNING

There is no rollover protection when the roll bar is in the down position.

- Lower the roll bar only when absolutely necessary.
- Do not wear the seat belt when the roll bar is in the down position.
- Drive slowly and carefully.
- Raise the roll bar as soon as clearance permits.
- Check carefully for overhead clearances (i.e., branches, doorways, electrical wires) before driving under any objects and do not contact them.

## Lowering the Roll Bar

**Important:** Lower the roll bar only when absolutely necessary.

1. To lower the roll bar, apply forward pressure to the upper part of the roll bar.
2. Pull both knobs out and rotate them 90 degrees so they are not engaged (Figure 8).
3. Lower the roll bar to the down position (Figure 8).

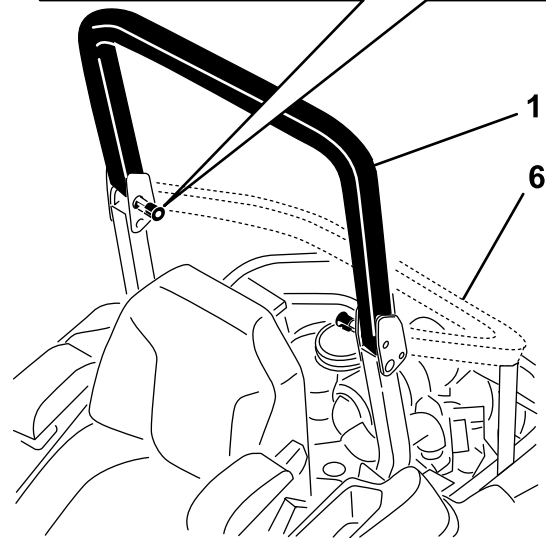
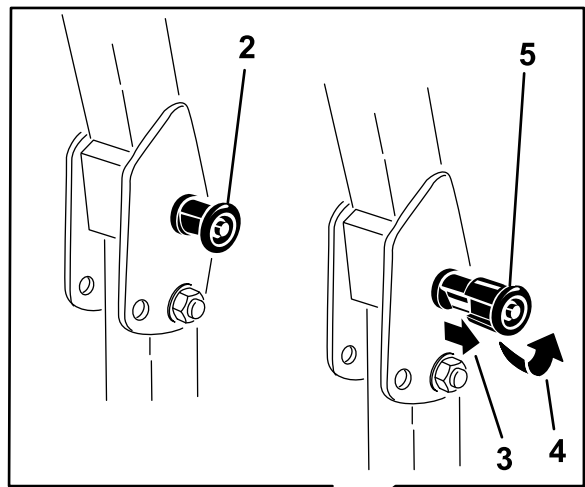

Figure 8

g228804

1. Roll bar in the upright position
2. ROPS knob in the latched position
3. Pull the ROPS knob out.
4. Rotate the ROPS knob 90 degrees.
5. ROPS knob in the unlatched position
6. Roll bar in the folded position

## Raising the Roll Bar

**Important:** Always use the seat belt with the roll bar in the raised position.

1. Raise the roll bar to the operating position and rotate the knobs until they move partially into the grooves (Figure 8).
2. Raise the roll bar to the full upright position while pushing on the upper roll bar so that the pins snap into position when the holes align with the pins (Figure 8).
3. Push on the roll bar and ensure that both pins are engaged.

# Using the Safety-Interlock System

## ⚠ WARNING

If the safety-interlock switches are disconnected or damaged, the machine could operate unexpectedly, causing personal injury.

- Do not tamper with the interlock switches.
- Check the operation of the interlock switches daily and replace any damaged switches before operating the machine.

## Understanding the Safety-Interlock System

The safety-interlock system is designed to prevent the engine from starting unless:

- The parking brake is engaged.
- The blade-control switch (PTO) is disengaged.
- The motion-control levers are in the NEUTRAL-LOCK position.

The safety-interlock system also is designed to shut off the engine when the motion-control levers are moved from the NEUTRAL-LOCK position with the parking brake engaged or if you rise from the seat when the PTO is engaged.

The Horizon Display Monitor has symbols to notify the user when the interlock component is in the correct position. When the component is in the correct position, the corresponding symbol displays on the monitor.

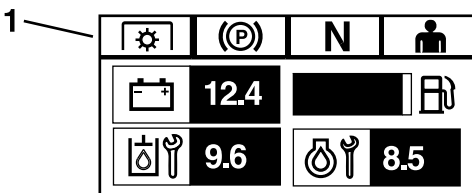

Figure 9

g230650

1. Symbols display on the monitor when the interlock components are in the correct position.

# Testing the Safety-Interlock System

**Service Interval:** Before each use or daily

Test the safety-interlock system before you use the machine each time. If the safety system does not operate as described below, have an Authorized Service Dealer repair the safety system immediately.

1. Sit on the seat, engage the parking brake, and move the blade-control switch (PTO) to the ON position. Try starting the engine; the engine should not start.
2. Sit on the seat, engage the parking brake, and move the blade-control switch (PTO) to the OFF position. Move either motion-control lever out of the NEUTRAL-LOCK position. Try starting the engine; the engine should not start. Repeat for the other control lever.
3. Sit on the seat, engage the parking brake, move the blade-control switch (PTO) to the OFF position, and move the motion-control levers to the NEUTRAL-LOCK position. Now start the engine. While the engine is running, disengage the parking brake, engage the blade-control switch (PTO), and rise slightly from the seat; the engine should shut off.
4. Sit on the seat, engage the parking brake, move the blade-control switch (PTO) to the OFF position, and move the motion-control levers to the NEUTRAL-LOCK position. Now start the engine. While the engine is running, center either motion control and move (forward or reverse); the engine should shut off. Repeat for other motion control.
5. Sit on the seat, disengage the parking brake, move the blade-control switch (PTO) to the OFF position, and move the motion-control levers to the NEUTRAL-LOCK position. Try starting the engine; the engine should not start.

## Positioning the Seat

The seat can move forward and backward. Position the seat where you have the best control of the machine and are most comfortable (Figure 10).

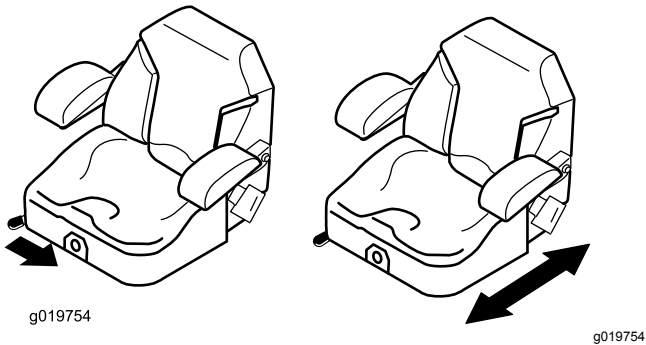

Figure 10

## Unlatching the Seat

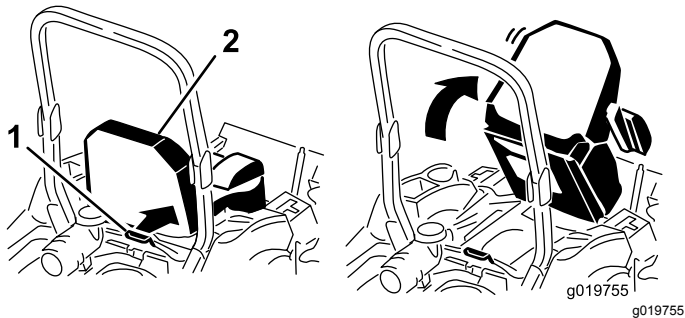

Figure 11

1. Seat latch

2. Seat

## Changing the Seat Suspension

The seat adjusts to provide a smooth and comfortable ride. Position the seat where you are most comfortable.

To adjust, turn the knob in front either direction to provide the best comfort (Figure 12).

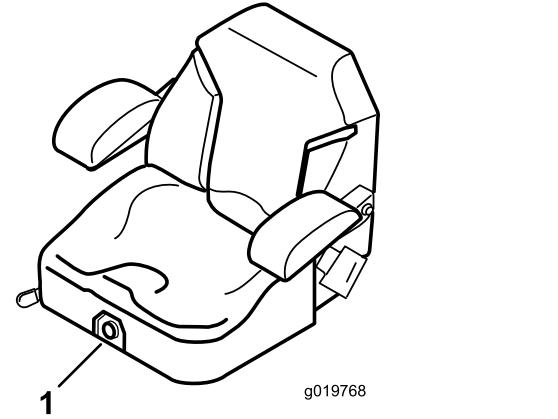

Figure 12

1. Seat-suspension knob

# ***During Operation***

## **During Operation Safety**

### **General Safety**

- The owner/operator can prevent and is responsible for accidents that may cause personal injury or property damage.
- Wear appropriate clothing, including eye protection; long pants; slip-resistant, substantial footwear; and hearing protection. Tie back long hair and do not wear loose jewelry.
- Use your full attention while operating the machine. Do not engage in any activity that causes distractions; otherwise, injury or property damage may occur.
- Do not operate the machine while ill, tired, or under the influence of alcohol or drugs.
- Never carry passengers on the machine and keep bystanders and pets away from the machine during operation.
- Operate the machine only in good visibility to avoid holes or hidden hazards.
- Avoid mowing on wet grass. Reduced traction could cause the machine to slide.
- Ensure that all drives are in neutral, the parking brake is engaged, and you are in the operating position before you start the engine.
- Keep your hands and feet away from the cutting units. Keep clear of the discharge opening at all times.
- Look behind and down before backing up to be sure of a clear path.
- Use care when approaching blind corners, shrubs, trees, or other objects that may obscure your vision.
- Do not mow near drop-offs, ditches, or embankments. The machine could suddenly roll over if a wheel goes over the edge or if the edge gives way.
- Stop the blades whenever you are not mowing.
- Stop the machine, shut off the engine, remove the key, and inspect the blades after striking an object or if there is an abnormal vibration in the machine. Make all necessary repairs before resuming operation.
- Slow down and use caution when making turns and crossing roads and sidewalks with the machine. Always yield the right-of-way.
- Disengage the drive to the cutting unit, shut off the engine, and remove the key before adjusting the height of cut (unless you can adjust it from the operating position).

- Never run an engine in an area where exhaust gases are enclosed.
- Never leave a running machine unattended.
- Before leaving the operating position (including to empty the catchers or to unclog the chute), do the following:
  - Stop the machine on level ground.
  - Disengage the power takeoff and lower the attachments.
  - Engage the parking brake.
  - Shut off the engine and remove the key.
  - Wait for all moving parts to stop.
- Do not operate the machine when there is the risk of lightning.
- Do not use the machine as a towing vehicle unless it has a hitch installed.
- Do not change the governor speed or overspeed the engine.
- Use only accessories and attachments approved by Toro.
- This machine produces sound levels in excess of 85 dBA at the operator's ear and can cause hearing loss through extended periods of exposure.

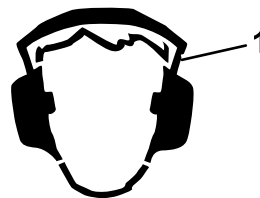

**Figure 13**

g229846

1. Wear hearing protection.

---

## **Rollover Protection System (ROPS) Safety**

- **Do not** remove the roll bar from the machine.
- Ensure that the seat belt is attached and that you can release it quickly in an emergency.
- Always wear your seat belt when the roll bar is up.
- Check carefully for overhead obstructions and do not contact them.
- Keep the roll bar in safe operating condition by thoroughly inspecting it periodically for damage and keeping all the mounting fasteners tight.
- Replace a damaged roll bar. Do not repair or alter it.

## **Slope Safety**

- Slopes are a major factor related to loss of control and rollover accidents, which can result in severe

injury or death. The operator is responsible for safe slope operation. Operating the machine on any slope requires extra caution. Before using the machine on a slope, do the following:

- Review and understand the slope instructions in the manual and on the machine.
  - Use an angle indicator to determine the approximate slope angle of the area.
  - Never operate on slopes greater than 15 degrees.
  - Evaluate the site conditions of the day to determine if the slope is safe for machine operation. Use common sense and good judgment when performing this evaluation. Changes in the terrain, such as moisture, can quickly affect the operation of the machine on a slope.
- Identify hazards at the base of the slope. Do not operate the machine near drop-offs, ditches, embankments, water, or other hazards. The machine could suddenly roll over if a wheel goes over the edge or the edge collapses. Keep a safe distance (twice the width of the machine) between the machine and any hazard. Use a walk-behind mower or a hand trimmer to mow the grass in these areas.
  - Avoid starting, stopping, or turning the machine on slopes. Avoid making sudden changes in speed or direction; turn slowly and gradually.
  - Do not operate a machine under any conditions where traction, steering, or stability is in question. Be aware that operating the machine on wet grass, across slopes, or downhill may cause the machine to lose traction. Loss of traction to the drive wheels may result in sliding and a loss of braking and steering. The machine can slide even if the drive wheels are stopped.
  - Remove or mark obstacles such as ditches, holes, ruts, bumps, rocks, or other hidden hazards. Tall grass can hide obstacles. Uneven terrain could overturn the machine.
  - Use extra care while operating with accessories or attachments, such as grass-collection systems. These can change the stability of the machine and cause a loss of control. Follow directions for counterweights.
  - If possible, keep the deck lowered to the ground while operating on slopes. Raising the deck while operating on slopes can cause the machine to become unstable.

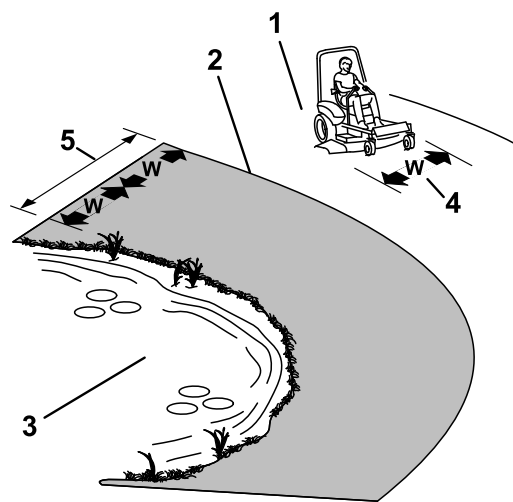

**Figure 14**

g221745

1. Safe Zone—use the machine here on slopes less than 15 degrees or flat areas.
2. Danger Zone—use a walk-behind mower and/or a hand trimmer on slopes greater than 15 degrees and near drop-offs or water.
3. Water
4. W=width of the machine
5. Keep a safe distance (twice the width of the machine) between the machine and any hazard.

## Operating the Parking Brake

Always engage the parking brake when you stop the machine or leave it unattended.

### Engaging the Parking Brake

Park the machine on a level surface.

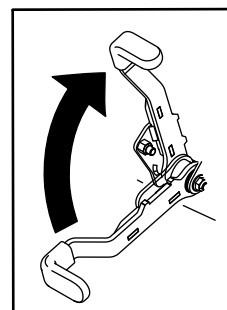

g027334

**Figure 15**

g027334

## Disengaging the Parking Brake

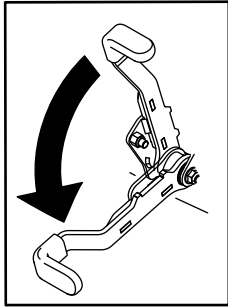

g027335

Figure 16

g027335

## Operating the Mower Blade-Control Switch (PTO)

The blade-control switch (PTO) starts and stops the mower blades and any powered attachments.

### Engaging the Blade-Control Switch (PTO)

**Note:** Engaging the blade-control switch (PTO) with the throttle position at half or less causes excessive wear to the drive belts.

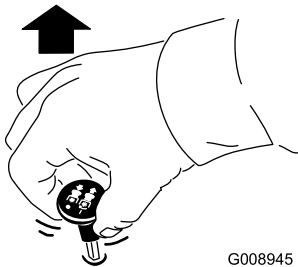

G008945

Figure 17

g008945

### Disengaging the Blade-Control Switch (PTO)

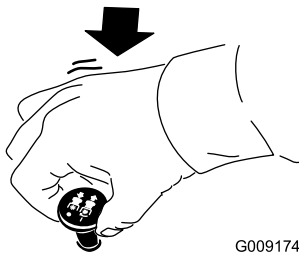

G009174

Figure 18

g009174

## Starting the Engine

**Important:** Do not engage starter for more than 5 seconds at a time. If the engine fails to start, wait 15 seconds between attempts. Failure to follow these instructions can burn out the starter motor.

**Note:** You may need multiple attempts to start the engine the first time after adding fuel to an empty fuel system.

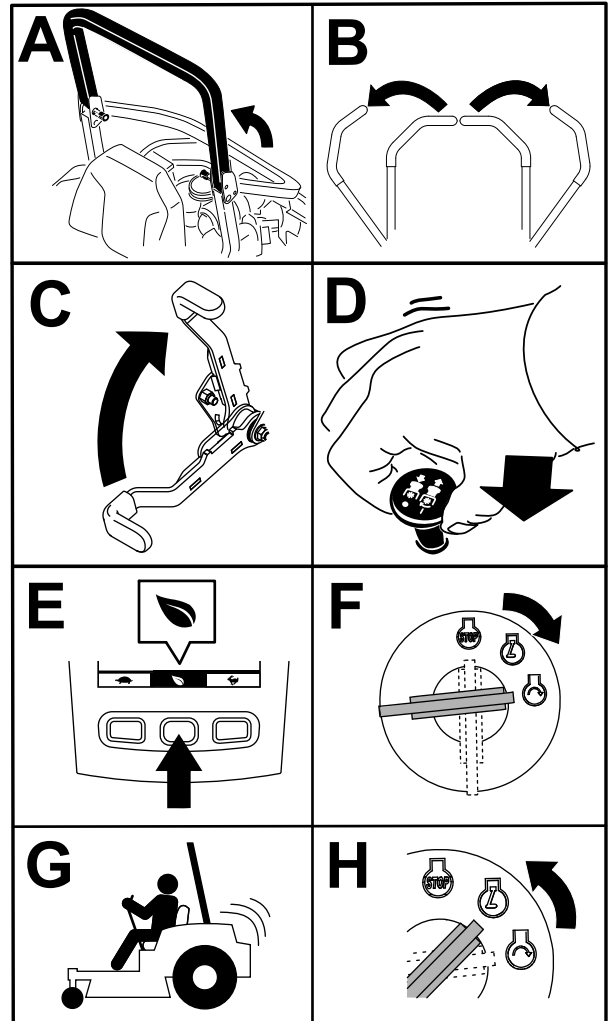

Figure 19

g230704

# Shutting Off the Engine

## ⚠ CAUTION

Children or bystanders may be injured if they move or attempt to operate the machine while it is unattended.

Always remove the key and engage the parking brake when leaving the machine unattended.

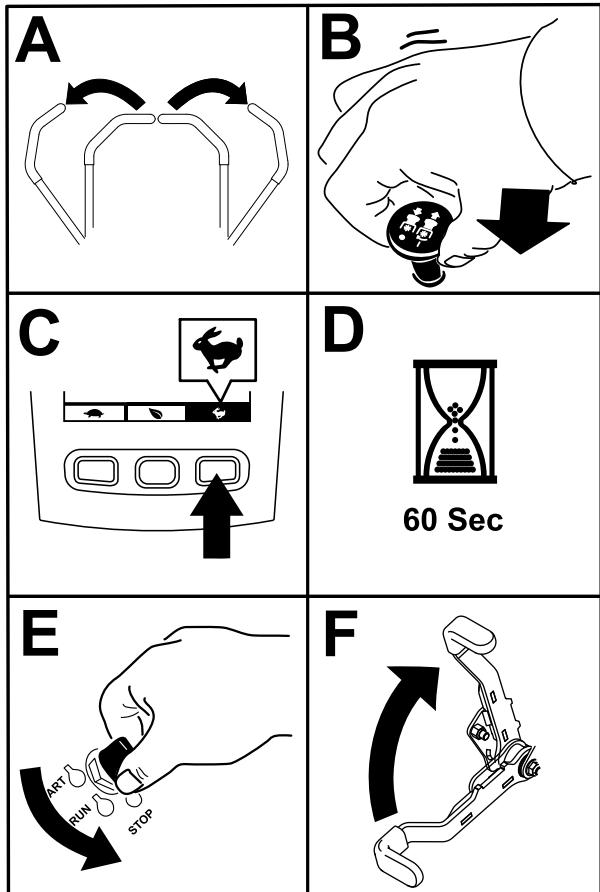
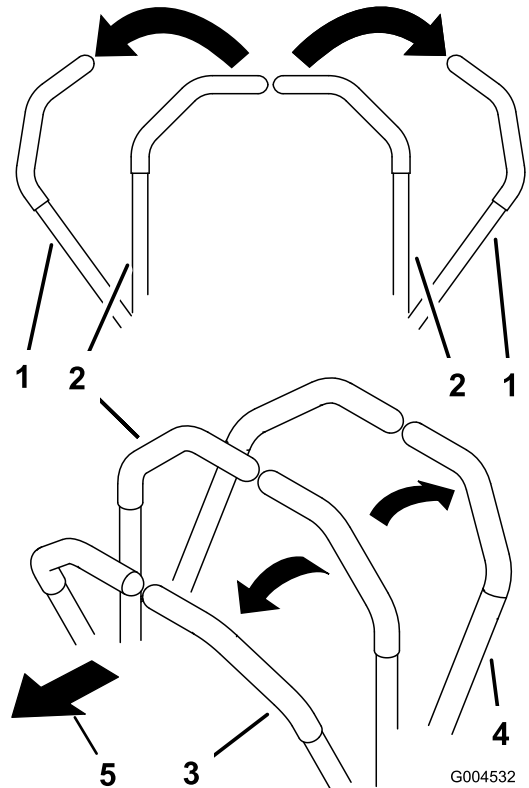

Figure 20

g230715

**Important:** Make sure that the fuel-shutoff valve is closed before transporting or storing the machine, as fuel leakage may occur. Engage the parking brake before transporting. Make sure that you remove the key as the fuel pump may run and cause the battery to lose charge.

# Using the Motion-Control Levers



G004532

Figure 21

g004532

- 1. Motion-control lever—NEUTRAL-LOCK position
- 2. Center, unlocked position
- 3. Forward
- 4. Backward
- 5. Front of machine

# Driving the Machine

The drive wheels turn independently, powered by hydraulic motors on each axle. You can turn 1 side in reverse while you turn the other forward, causing the machine to spin rather than turn. This greatly improves the machine maneuverability but may require some time for you to adapt to how it moves.

The throttle control regulates the engine speed as measured in rpm (revolutions per minute). Place the throttle control in the FAST position for best performance. Always operate in the full throttle position when mowing.

## ⚠ WARNING

The machine can spin very rapidly. You may lose control of the machine and cause personal injury or damage to the machine.

- Use caution when making turns.
- Slow the machine down before making sharp turns.

## Driving Forward

**Note:** The engine shuts off when you move the traction-control with the parking brake engaged.

To stop the machine, pull the motion-control levers to the NEUTRAL position.

1. Disengage the parking brake; refer to [Disengaging the Parking Brake \(page 21\)](#).
2. Move the levers to the center, unlocked position.
3. To go forward, slowly push the motion-control levers forward ([Figure 22](#)).

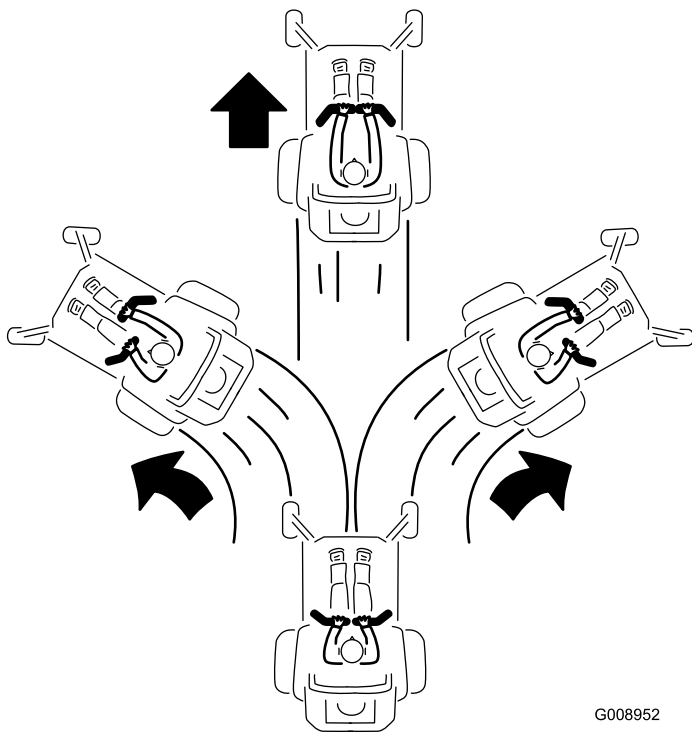
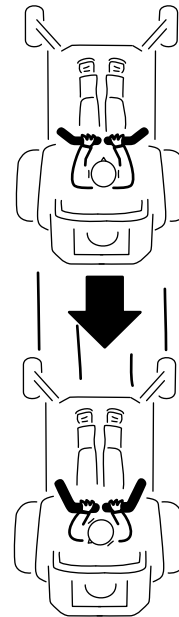

Figure 22

G008952  
g008952

## Driving Backward

1. Move the levers to the center, unlocked position.
2. To go backward, slowly pull the motion-control levers rearward ([Figure 23](#)).



G008953

g008953

Figure 23

## Using the Side Discharge

The mower has a hinged grass deflector that disperses clippings to the side and down toward the turf.

### **⚠ DANGER**

Without a grass deflector, discharge cover, or a complete grass-catcher assembly mounted in place, you and others are exposed to blade contact and thrown debris. Contact with rotating mower blade(s) and thrown debris will cause injury or death.

- Never remove the grass deflector from the mower deck because the grass deflector routes material down toward the turf. If the grass deflector is ever damaged, replace it immediately.
- Never put your hands or feet under the mower deck.
- Never try to clear the discharge area or mower blades unless you move the blade-control switch (PTO) to the OFF position, rotate the key switch to the OFF position, and remove the key from the key switch.
- Make sure that the grass deflector is in the down position.

## Adjusting the Height of Cut

### Using the Transport Lock

The transport lock has 2 positions, and is used with the deck-lift pedal. There is a LOCK position and an UNLOCK position for the transport position of the mower deck (Figure 24).

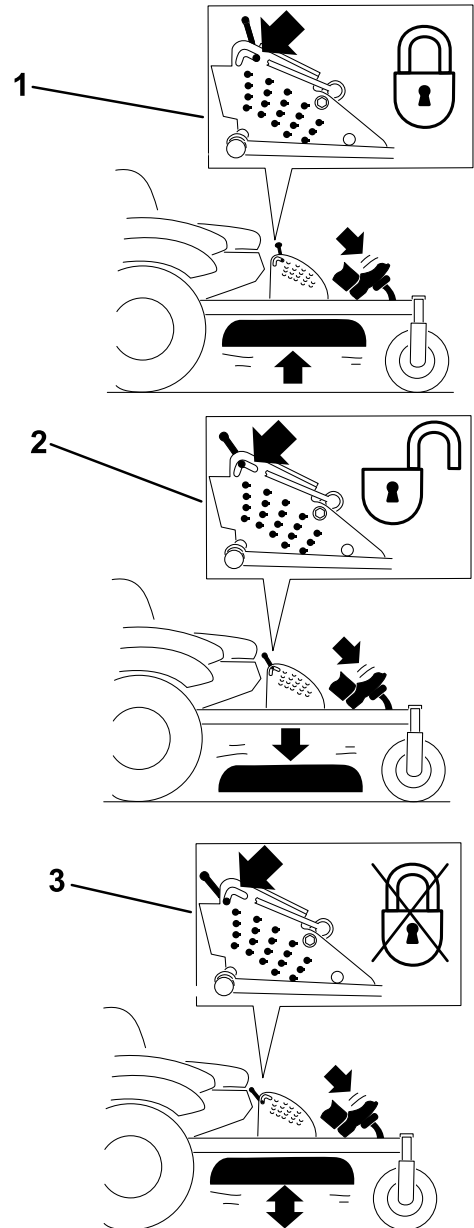

**Figure 24**

Transport-Lock Positions

1. Transport lock knob
2. LOCK position—The mower deck locks into the transport position.
3. UNLOCK position—The mower deck does not lock into the transport position.

g229103

## Adjusting the Height-of-Cut Pin

The height-of-cut is adjusted from 25 to 140 mm (1 to 5-1/2 inches) in 6 mm (1/4 inch) increments by relocating the clevis pin into different hole locations.

1. Move the transport lock to the lock position.
2. Push on the deck-lift pedal with your foot, and raise the mower deck to the transport position (also the 140 mm (5-1/2 inches) cutting height position) as shown in [Figure 25](#).
3. To adjust, rotate the pin 90 degrees and remove the pin from the height-of-cut bracket ([Figure 25](#)).
4. Select a hole in the height-of-cut bracket corresponding to the height-of-cut desired, and insert the pin ([Figure 25](#)).
5. Push on the deck lift, pull back on the transport lock, and slowly lower the mower deck.

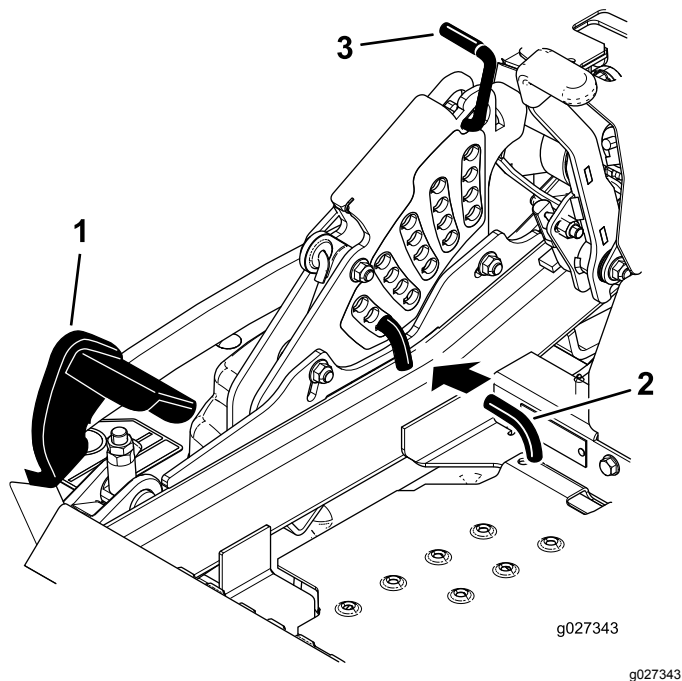

**Figure 25**

1. Deck-lift pedal
2. Cut-of-height pin
3. Transport lock

## Adjusting the Anti-Scalp Rollers

Whenever you change the height-of-cut, it is recommended to adjust the height of the anti-scalp rollers.

1. Park the machine on a level surface, disengage the blade-control switch, and engage the parking brake.
2. Shut off the engine, remove the key, and wait for all moving parts to stop before leaving the operating position.
3. Adjust the anti-scalp rollers as shown in [Figure 26](#) and [Figure 27](#).

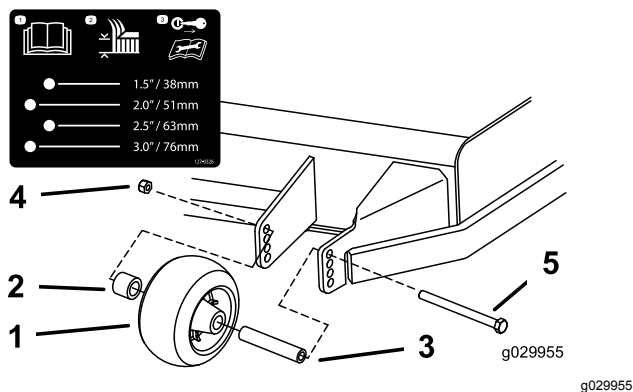

**Figure 26**

1. Anti-scalp roller
2. Spacer
3. Bushing
4. Flange nut
5. Bolt

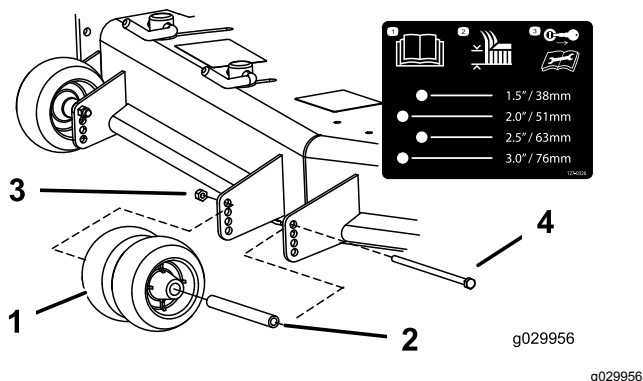

**Figure 27**

1. Anti-scalp roller
2. Bushing
3. Flange nut
4. Bolt

# Adjusting the Flow Baffle Cam Locks

This procedure is applicable only to machines with the flow-baffle locks. Certain models have nuts and bolts in place of the flow-baffle locks and can be adjusted the same.

You can adjust the mower-discharge flow for different types of mowing conditions. Position the cam locks and baffle to give the best quality of cut.

1. Park the machine on a level surface, disengage the blade-control switch, and engage the parking brake.
2. Shut off the engine, remove the key, and wait for all moving parts to stop before leaving the operating position.
3. To adjust the cam locks, swing the lever up to loosen the cam lock (Figure 28).
4. Adjust the baffle and cam locks in the slots to the desired discharge flow.
5. Swing the lever back over to tighten the baffle and cam locks (Figure 28).
6. If the cam locks do not lock the baffle into place or it is too tight, loosen the lever and then rotate the cam lock.

**Note:** Adjust the cam lock until the desired locking pressure is achieved.

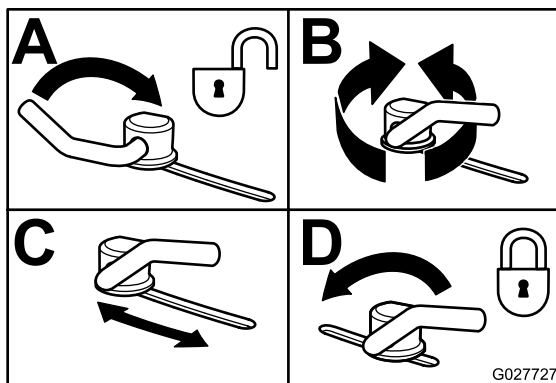

Figure 28

G027727

# Positioning the Flow Baffle

The following figures are only recommendations for use. Adjustments vary by grass type, moisture content, and the height of the grass.

**Note:** If the engine power draws down and the mower ground speed is the same, open up the baffle.

## Position A

This is the full rear position. The suggested use for this position is as follows:

- Short, light grass mowing conditions
- Dry conditions
- Smaller grass clippings
- Propels grass clippings farther away from the mower

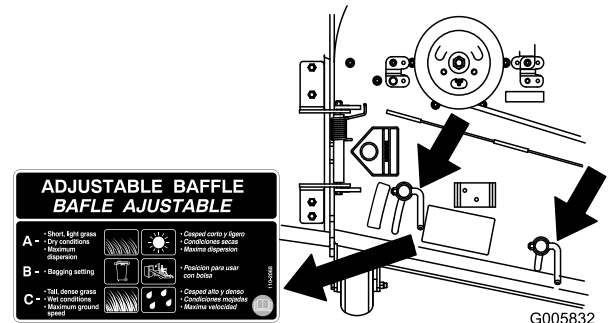

Figure 29

G005832

## Position B

Use this position when bagging. Always align it with the blower opening.

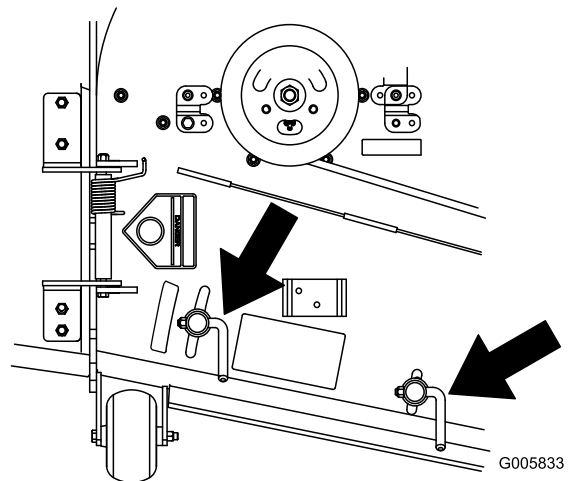

Figure 30

G005833

## Position C

This is the full open position. The suggested use for this position is as follows:

- Tall, dense grass mowing conditions
- Wet conditions
- Lowers the engine-power consumption
- Allows increased ground speed in heavy conditions

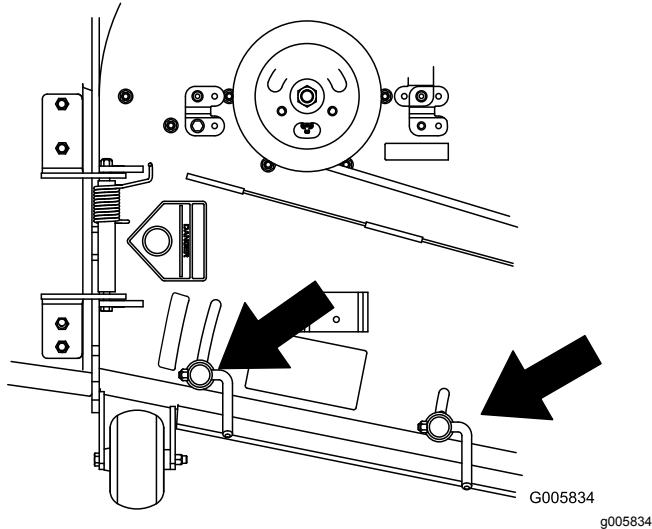

Figure 31

---

## Operating Tips

### Using the Fast Throttle Setting

For best mowing and maximum air circulation, operate the engine at the FAST position. Air is required to thoroughly cut grass clippings, so do not set the height-of-cut so low as to totally surround the mower deck in uncut grass. Always try to have 1 side of the mower deck free from uncut grass, which allows air to be drawn into the mower deck.

### Cutting a Lawn for the First Time

Cut grass slightly longer than normal to ensure that the cutting height of the mower deck does not scalp any uneven ground. However, the cutting height used in the past is generally the best one to use. When cutting grass longer than 15 cm (6 inches) tall, you may want to cut the lawn twice to ensure an acceptable quality of cut.

### Cutting a Third of the Grass Blade

It is best to cut only about a third of the grass blade. Cutting more than that is not recommended unless grass is sparse, or it is late fall when grass grows more slowly.

## Alternating the Mowing Direction

Alternate the mowing direction to keep the grass standing straight. This also helps disperse clippings, which enhances decomposition and fertilization.

## Mowing at Correct Intervals

Grass grows at different rates at different times of the year. To maintain the same cutting height, mow more often in early spring. As the grass growth rate slows in mid summer, mow less frequently. If you cannot mow for an extended period, first mow at a high cutting height, then mow again 2 days later at a lower height setting.

## Using a Slower Cutting Speed

To improve cut quality, use a slower ground speed in certain conditions.

## Avoiding Cutting Too Low

When mowing uneven turf, raise the cutting height to avoid scalping the turf.

## Stopping the Machine

If you must stop the forward motion of the machine while mowing, a clump of grass clippings may drop onto your lawn. To avoid this, move onto a previously cut area with the blades engaged or you can disengage the mower deck while moving forward.

## Keeping the Underside of the Mower Deck Clean

Clean clippings and dirt from the underside of the mower deck after each use. If grass and dirt build up inside the mower deck, cutting quality will eventually become unsatisfactory.

## Maintaining the Blade(s)

Maintain a sharp blade throughout the cutting season because a sharp blade cuts cleanly without tearing or shredding the grass blades. Tearing and shredding turns grass brown at the edges, which slows growth and increases the chance of disease. Check the mower blades after each use for sharpness, and for any wear or damage. File down any nicks and sharpen the blades as necessary. If a blade is damaged or worn, replace it immediately with a genuine Toro replacement blade.

# After Operation

## After Operation Safety

### General Safety

- Clean grass and debris from the cutting units, mufflers, and engine compartment to help prevent fires. Clean up oil or fuel spills.
- Shut off the fuel and remove the key before storing or transporting the machine.
- Disengage the drive to the attachment whenever you are transporting or not using the machine.
- Allow the engine to cool before storing the machine in any enclosure.
- Never store the machine or fuel container where there is an open flame, spark, or pilot light, such as on a water heater or on other appliances.

## Using the Fuel-Shutoff Valve

The fuel-shutoff valve is located under the seat. Move the seat forward to access it.

Close the fuel-shutoff valve for transport, maintenance, and storage.

Ensure that the fuel-shutoff valve is open when starting the engine.

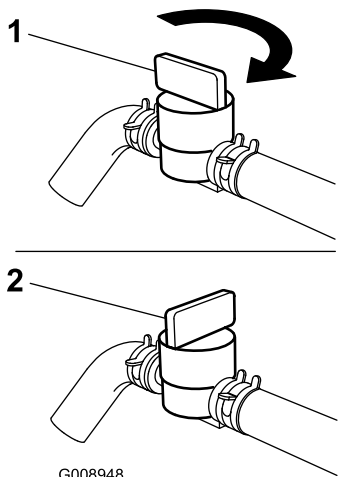

Figure 32

1. ON position

2. OFF position

## Using the Drive-Wheel-Release Valves

### ⚠ WARNING

Hands may become entangled in the rotating drive components below the engine deck, which could result in serious injury.

**Shut off the engine, remove the key, and allow all moving parts to stop before accessing the drive-wheel-release valves.**

### ⚠ WARNING

The engine and hydraulic-drive units can become very hot. Touching a hot engine or hydraulic-drive units can cause severe burns.

**Allow the engine and hydraulic-drive units to cool completely before accessing the drive-wheel-release valves.**

The drive-wheel-release valves are located in the back of each hydraulic-drive unit, under the seat.

**Note:** Make sure that the release valves are in the fully horizontal position when operating the machine; otherwise, severe damage to the hydraulic system can occur.

1. Park the machine on a level surface, disengage the blade-control switch, and engage the parking brake.
2. Shut off the engine, remove the key, and wait for all moving parts to stop before leaving the operating position.
3. Rotate the release-valve levers vertically to push the machine (Figure 33).

**Note:** This allows hydraulic fluid to bypass the pump, enabling the wheels to turn.

4. Disengage the parking brake before pushing the machine.

# Transporting the Machine

Use a heavy-duty trailer or truck to transport the machine. Use a full-width ramp. Ensure that the trailer or truck has all the necessary brakes, lighting, and marking as required by law. Please carefully read all the safety instructions. Knowing this information could help you or bystanders avoid injury. Refer to your local ordinances for trailer and tie-down requirements.

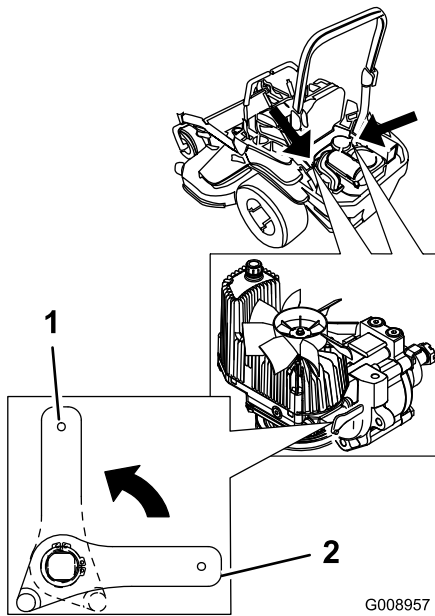

Figure 33

1. Vertical to push the machine
2. Horizontal to run the machine

5. Rotate the release valve levers horizontally to run the machine (Figure 33).

## ⚠ WARNING

Driving on the street or roadway without turn signals, lights, reflective markings, or a slow-moving-vehicle emblem is dangerous and can lead to accidents, causing personal injury.

Do not drive the machine on a public street or roadway.

## Selecting a Trailer

### ⚠ WARNING

Loading a machine onto a trailer or truck increases the possibility of tip-over and could cause serious injury or death (Figure 34).

- Use only a full-width ramp; do not use individual ramps for each side of the machine.
- Do not exceed a 15-degree angle between the ramp and the ground or between the ramp and the trailer or truck.
- Ensure that the length of ramp is at least 4 times as long as the height of the trailer or truck bed to the ground. This ensures that ramp angle does not exceed 15 degrees on flat ground.

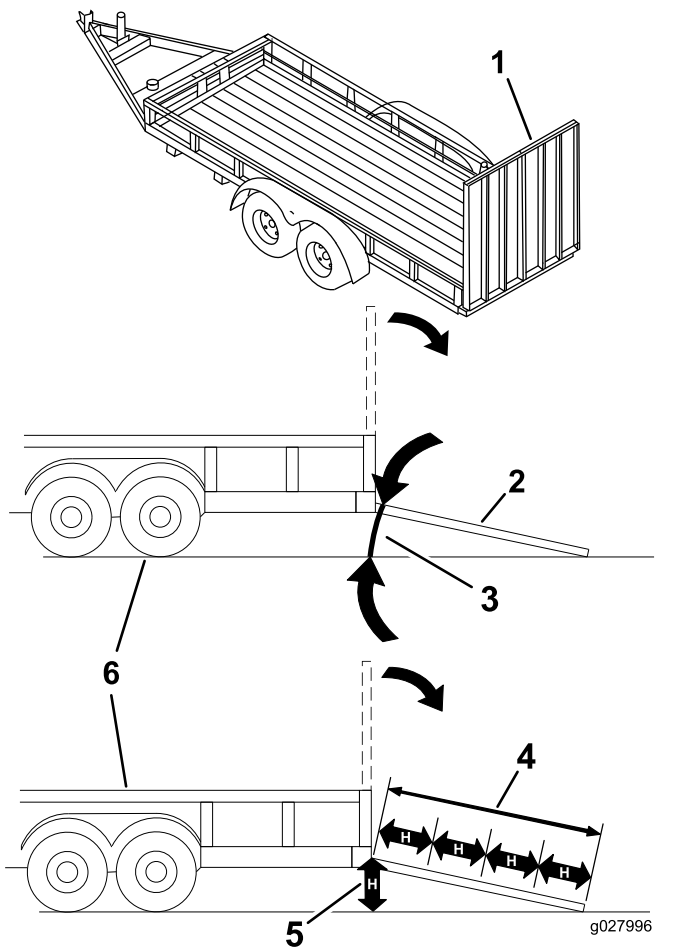

Figure 34

- |   |   |
|---|---|
| 1. Full-width ramp in stowed position               | 4. Ramp is at least 4 times as long as the height of the trailer or truck bed to the ground |
| 2. Side view of full-width ramp in loading position | 5. H=height of the trailer or truck bed to the ground                                       |
| 3. Not greater than 15 degrees                      | 6. Trailer  |

## Loading the Machine

### ⚠ WARNING

Loading a machine onto a trailer or truck increases the possibility of tip-over and could cause serious injury or death.

- Use extreme caution when operating a machine on a ramp.
- Back the machine up the ramp and drive it forward down the ramp.
- Avoid sudden acceleration or deceleration while driving the machine on a ramp as this could cause a loss of control or a tip-over situation.

1. If using a trailer, connect it to the towing vehicle and connect the safety chains.
2. If applicable, connect the trailer brakes and lights.
3. Lower the ramp, ensuring that the angle between the ramp and the ground does not exceed 15 degrees (Figure 34).
4. Back the machine up the ramp (Figure 35).

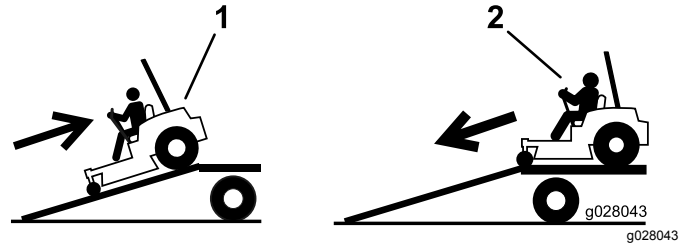

Figure 35

1. Back the machine up the ramp.
2. Drive the machine forward down the ramp.

5. Shut off the engine, remove the key, and engage the parking brake.
6. Tie down the machine near the front caster wheels and the rear bumper with straps, chains, cable, or ropes (Figure 36). Refer to local regulations for tie-down requirements.

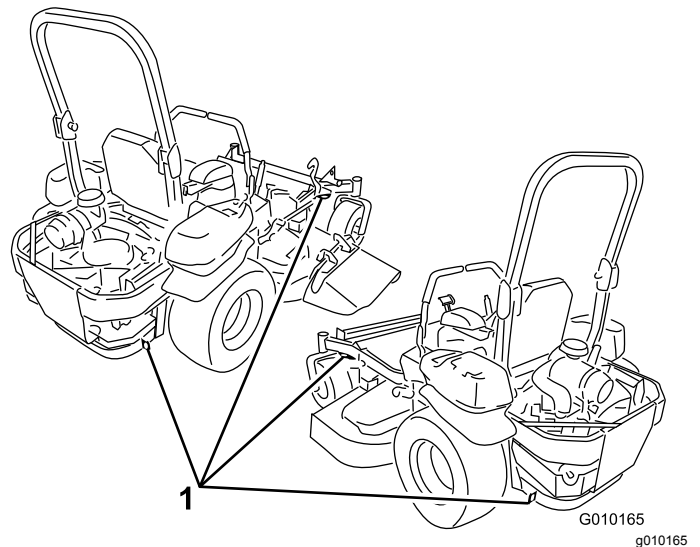

Figure 36

1. Tie-down loops

## Unloading the Machine

1. Lower the ramp, ensuring that the angle between the ramp and the ground does not exceed 15 degrees (Figure 34).
2. Drive the machine forward down the ramp (Figure 35).

# Maintenance

Determine the left and right sides of the machine from the normal operating position.

## Recommended Maintenance Schedule(s)

| Maintenance Service Interval | Maintenance Procedure   |
|------------------------------|---|
| After the first 100 hours    | <ul style="list-style-type: none"> <li>• Check the wheel lug-nut torque.</li> <li>• Check the wheel-hub slotted-nut torque.</li> <li>• Check the parking brake adjustment.</li> </ul>   |
| After the first 250 hours    | <ul style="list-style-type: none"> <li>• Change the hydraulic filters and hydraulic fluid when using any type of fluid.</li> </ul>  |
| Before each use or daily     | <ul style="list-style-type: none"> <li>• Check the safety system.</li> <li>• For Kawasaki engines—check the engine-oil level.</li> <li>• For Kohler engines—check the engine-oil level.</li> <li>• Check the seat belt.</li> <li>• Check the roll bar knobs.</li> <li>• Clean the engine screen and the oil cooler.</li> <li>• Check and clean the hydraulic-unit shrouds.</li> <li>• Inspect the blades.</li> <li>• Clean the mower deck.</li> </ul> |
| Every 40 hours               | <ul style="list-style-type: none"> <li>• Check the tire pressure.</li> </ul>  |
| Every 50 hours               | <ul style="list-style-type: none"> <li>• Check the spark arrester (if equipped).</li> <li>• Inspect the belts for cracks and wear.</li> <li>• Check the hydraulic-fluid level.</li> </ul>   |
| Every 100 hours              | <ul style="list-style-type: none"> <li>• Lubricate the mower deck-lift pivots.</li> <li>• For Kawasaki engines—change the engine oil (more often in dirty or dusty conditions).</li> <li>• For Kawasaki engines—replace or clean and gap the spark plug.</li> <li>• For Kohler engines—change the engine oil and the engine-oil filter.</li> <li>• Check and clean engine-cooling fins and shrouds.</li> </ul>  |
| Every 150 hours              | <ul style="list-style-type: none"> <li>• For Kohler engines—inspect the primary filter.</li> </ul>  |
| Every 200 hours              | <ul style="list-style-type: none"> <li>• For Kawasaki engines—change the engine-oil filter (more often in dirty or dusty conditions).</li> <li>• For Kohler engines—check the spark plug(s).</li> <li>• Replace the fuel filter (more often in dirty or dusty conditions).</li> </ul>   |
| Every 250 hours              | <ul style="list-style-type: none"> <li>• For Kawasaki engines—replace the primary air filter (more often in dusty or sandy conditions).</li> <li>• For Kawasaki engines—check the safety air filter. (more often in dusty or sandy conditions).</li> <li>• Change the hydraulic filters and hydraulic fluid when using Mobil® 1 fluid (more often in dirty or dusty conditions).</li> </ul>   |
| Every 300 hours              | <ul style="list-style-type: none"> <li>• For Kawasaki engines—Check and adjust the valve clearance. See an Authorized Service Dealer.</li> <li>• For Kohler engines—replace the primary air filter (more often in dusty or sandy conditions).</li> <li>• For Kohler engines—check the inner air filter.</li> </ul>  |

| Maintenance Service Interval | Maintenance Procedure  |
|------------------------------|--|
| Every 500 hours              | <ul style="list-style-type: none"> <li>• For Kawasaki engines—replace the safety air filter. (more often in dusty or sandy conditions).</li> <li>• For Kohler engines—replace the spark plug(s).</li> <li>• Check the wheel lug-nut torque.</li> <li>• Check the wheel-hub slotted-nut torque.</li> <li>• Adjust the caster-pivot bearing.</li> <li>• Check the parking brake adjustment.</li> <li>• Change the hydraulic filters and hydraulic fluid when using Toro® HYPR-OIL™ 500 hydraulic fluid (more often in dirty or dusty conditions).</li> </ul> |
| Every 600 hours              | <ul style="list-style-type: none"> <li>• For Kohler engines—replace the inner air filter.</li> </ul>   |
| Monthly                      | <ul style="list-style-type: none"> <li>• Check the battery charge.</li> </ul>  |
| Yearly                       | <ul style="list-style-type: none"> <li>• Grease the pump-belt-idler arm.</li> <li>• Grease the front caster pivots (more often in dirty or dusty conditions).</li> <li>• Repack the front caster-wheel bearings (more often in dirty or dusty conditions).</li> <li>• Lubricate the caster-wheel hubs.</li> </ul>  |
| Yearly or before storage     | <ul style="list-style-type: none"> <li>• Paint chipped surfaces.</li> <li>• Check all maintenance procedures listed above before storage.</li> </ul>   |

**Important:** Refer to your engine owner's manual for additional maintenance procedures.

## ⚠ CAUTION

If you leave the key in the switch, someone could accidentally start the engine and seriously injure you or other bystanders.

Remove the key from the switch before you perform any maintenance.

## Pre-Maintenance Procedures

### Maintenance Safety

- Before repairing the machine do the following:
  - Disengage the drives.
  - Engage the parking brake.
  - Shut off the engine and remove the key.
  - Disconnect the spark-plug wire.
- Park the machine on a level surface.
- Clean grass and debris from the cutting unit, drives, mufflers, and engine to help prevent fires.
- Clean up oil or fuel spills.
- Do not allow untrained personnel to service the machine.
- Use jack stands to support the machine and/or components when required.
- Carefully release pressure from components with stored energy.
- Disconnect the battery or remove the spark-plug wire before making any repairs. Disconnect the

negative terminal first and the positive terminal last. Connect the positive terminal first and negative last.

- Use care when checking the blades. Wrap the blade(s) or wear thickly padded gloves, and use caution when servicing them. Only replace blades; do not straighten or weld them.
- Keep your hands and feet away from moving parts. If possible, do not make adjustments with the engine running.
- Keep all parts in good working condition and all hardware tightened, especially the blade-attachment bolts. Replace all worn or damaged decals.
- Never interfere with the intended function of a safety device or reduce the protection provided by a safety device. Check their proper operation regularly.
- Check the parking brake operation frequently. Adjust and service as required.

# Lubrication

## Greasing the Machine

Grease more frequently when operating conditions are extremely dusty or sandy.

**Grease Type:** No. 2 lithium or molybdenum grease

1. Park the machine on a level surface, disengage the blade-control switch, and engage the parking brake.
2. Shut off the engine, remove the key, and wait for all moving parts to stop before leaving the operating position.
3. Clean the grease fittings with a rag.

**Note:** Make sure that you scrape any paint off the front of the fitting(s).

4. Connect a grease gun to the fitting.
5. Pump grease into the fittings until grease begins to ooze out of the bearings.
6. Wipe up any excess grease.

## Adding Light Oil or Spray Lubrication

**Service Interval:** Every 100 hours

Lubricate the deck-lift pivots.

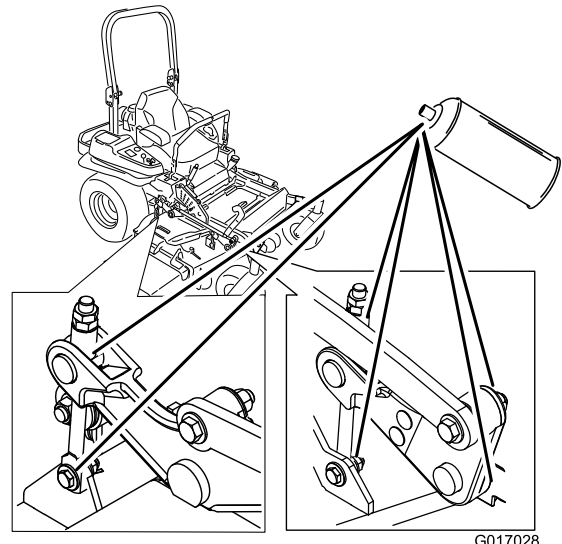

G017028

g017028

Figure 37

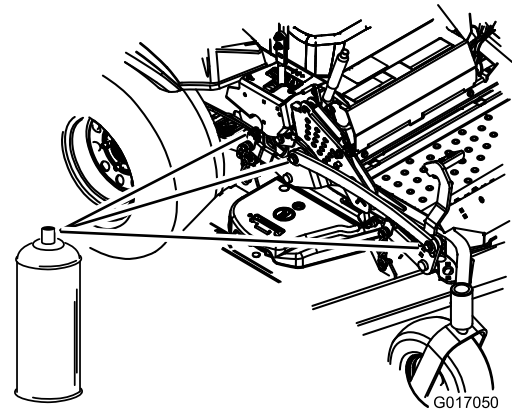

G017050

g017050

Figure 38

# Greasing the Mower Deck

**Service Interval:** Yearly—Grease the pump-belt-idler arm.

Yearly—Grease the front caster pivots (more often in dirty or dusty conditions).

Yearly—Repack the front caster-wheel bearings (more often in dirty or dusty conditions).

1. Park the machine on a level surface, disengage the blade-control switch, and engage the parking brake.
2. Shut off the engine, remove the key, and wait for all moving parts to stop before leaving the operating position.
3. Grease the mower deck idler-pulley pivot until grease comes out the bottom ([Figure 39](#)).

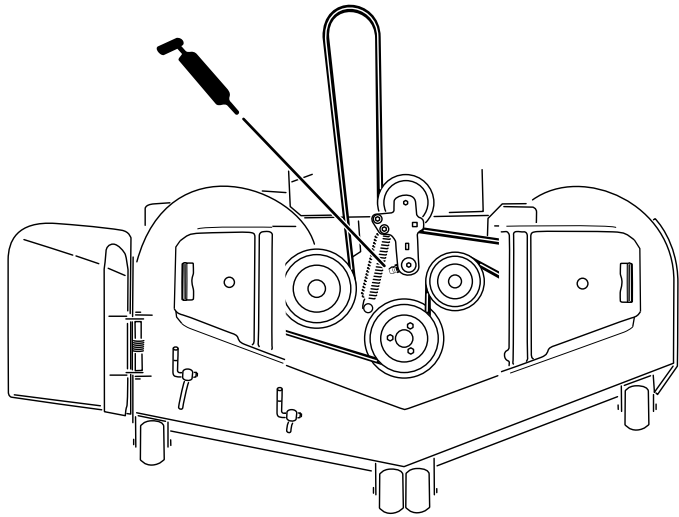

**Figure 39**

g185957

4. Grease the drive-belt-idler arm ([Figure 40](#)).

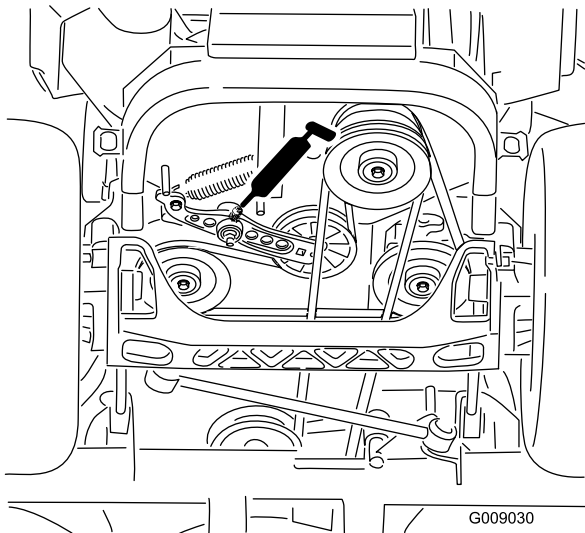

**Figure 40**

G009030

g009030

5. Remove the dust cap and adjust the caster pivots.

**Note:** Keep the dust cap off until greasing is done.

6. Remove the hex plug.
7. Thread a grease fitting into the hole.
8. Pump grease into the fitting until it oozes out around the top bearing.
9. Remove the grease fitting in the hole.
10. Install the hex plug and dust cap ([Figure 41](#)).

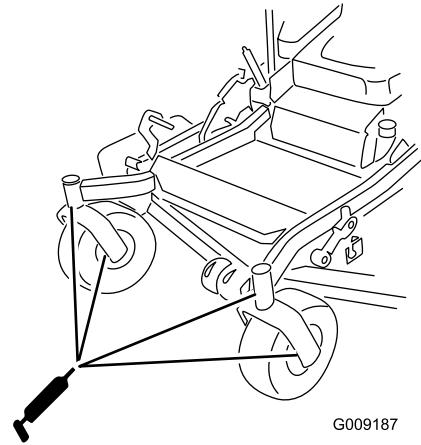

G009187

g009187

**Figure 41**

11. Grease the caster-wheel bearings ([Figure 41](#)).

# Lubricating the Caster-Wheel Hubs

**Service Interval:** Yearly

1. Park the machine on a level surface, disengage the blade-control switch, and engage the parking brake.
2. Shut off the engine, remove the key, and wait for all moving parts to stop before leaving the operating position.

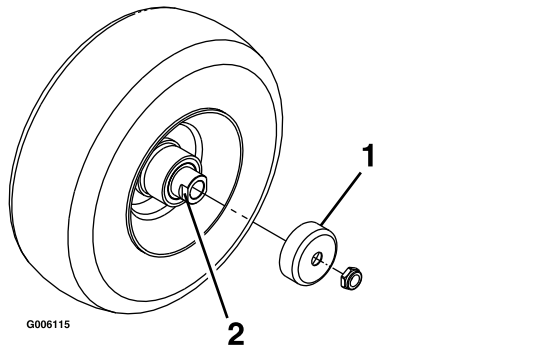

**Figure 42**

1. Seal guard
2. Spacer nut with wrench flats

3. Raise the mower for access.
4. Remove the caster wheel from the caster forks.
5. Remove the seal guards from the wheel hub.
6. Remove a spacer nut from the axle assembly in the caster wheel.

**Note:** Thread-locking adhesive has been applied to lock the spacer nuts to the axle.

7. Remove the axle (with the other spacer nut still assembled to it) from the wheel assembly.
8. Pry out seals and inspect bearings for wear or damage and replace if necessary.
9. Pack the bearings with a general-purpose grease.
10. Insert 1 bearing and 1 new seal into the wheel.

**Note:** Replace the seals.

11. If the axle assembly is missing both spacer nuts, apply a thread-locking adhesive to 1 spacer nut and thread it onto the axle with the wrench flats facing outward.

**Note:** Do not thread the spacer nut all of the way onto the end of the axle. Leave approximately 3 mm (1/8 inch) from the outer surface of the spacer nut to the end of the axle inside the nut.

12. Insert the assembled nut and axle into the wheel on the side of the wheel with the new seal and bearing.
13. With the open end of the wheel facing up, fill the area inside the wheel around the axle full of general-purpose grease.
14. Insert the second bearing and new seal into the wheel.
15. Apply a thread-locking adhesive to the second spacer nut, and thread it onto the axle with the wrench flats facing outward.
16. Torque the nut to 8 to 9 N·m (75 to 80 in-lb), loosen, then torque to 2 to 3 N·m (20 to 25 in-lb).
17. Install the seal guards over the wheel hub, and insert the wheel into the caster fork.
18. Install the caster bolt and tighten the nut fully.

**Important:** To prevent seal and bearing damage, check the bearing adjustment often. Spin the caster tire. The tire should not spin freely (more than 1 or 2 revolutions) or have any side play. If the wheel spins freely, adjust the torque on the spacer nut until there is a slight amount of drag. Apply another layer of thread-locking adhesive.

# Engine Maintenance

## Identifying the Engine

Use the following graphic to identify the engine you have and proceed to the section listed below for service (Figure 43).

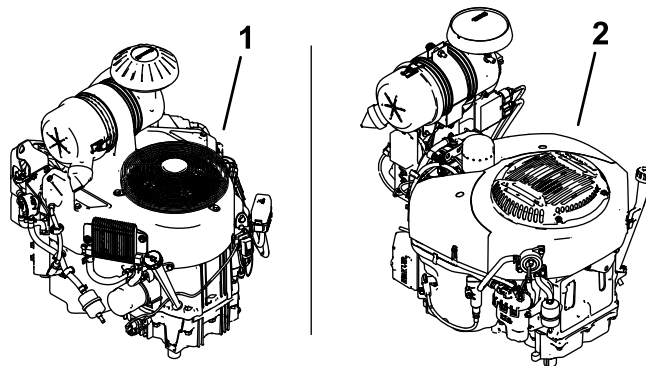

Figure 43

g230521

1. Kawasaki engine

2. Kohler engine

- For Kawasaki engine maintenance, refer to [Servicing a Kawasaki® Engine \(page 36\)](#).
- For Kohler engine maintenance, refer to [Replacing the Mower Belt \(page 57\)](#).

## Engine Safety

- Shut off the engine before checking the oil or adding oil to the crankcase.
- Keep your hands, feet, face, clothing, and other body parts away from the muffler and other hot surfaces.

## Servicing a Kawasaki® Engine

This section is only for machines with Kawasaki engines. If your engine looks like the one shown in Figure 44, you have a Kawasaki engine.

**Important:** Refer to your engine owner's manual for additional maintenance procedures.

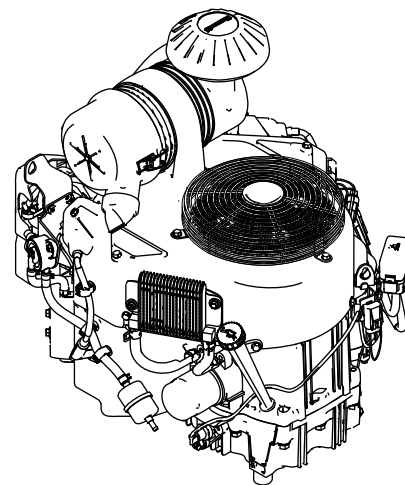

Figure 44

g230522

# Servicing the Air Cleaner

**Service Interval:** Every 250 hours—For Kawasaki engines—replace the primary air filter (more often in dusty or sandy conditions).

Every 250 hours—For Kawasaki engines—check the safety air filter. (more often in dusty or sandy conditions).

Every 500 hours—For Kawasaki engines—replace the safety air filter. (more often in dusty or sandy conditions).

**Note:** Check the filters more frequently if the operating conditions are extremely dusty or sandy.

## Removing the Filters

1. Park the machine on a level surface, disengage the blade-control switch (PTO), and engage the parking brake.
2. Shut off the engine, remove the key, and wait for all moving parts to stop before leaving the operating position.
3. Release the latches on the air cleaner and pull the air-cleaner cover off the air-cleaner body (Figure 45).

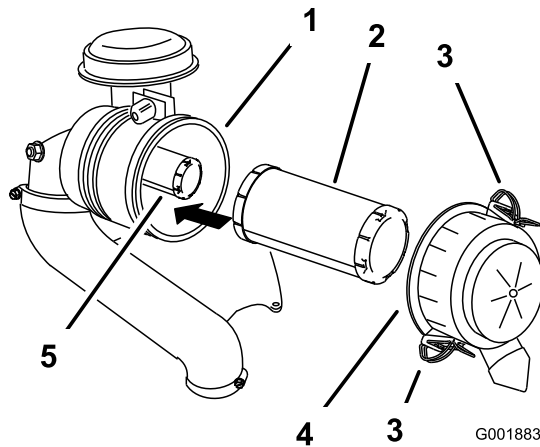

Figure 45

- |                     |                      |
|---------------------|----------------------|
| 1. Air-cleaner body | 4. Air-cleaner cover |
| 2. Primary filter   | 5. Safety filter     |
| 3. Latch            |                      |

4. Clean the inside of the air-cleaner cover with compressed air.
5. Gently slide the primary filter out of the air-cleaner body (Figure 45).

**Note:** Avoid knocking the filter into the side of the body.

6. Remove the safety filter only to replace it.

**Important:** Do not attempt to clean the safety filter. If the safety filter is dirty, then the primary filter is damaged. Replace both filters.

7. Inspect the primary filter for damage by looking into the filter while shining a bright light on the outside of the filter.

**Note:** Holes in the filter appear as bright spots. If the filter is damaged, discard it.

## Inspecting the Filters

1. Inspect the safety filter. If it is dirty, replace both the safety and primary filters.

**Important:** Do not attempt to clean the safety filter. If the safety filter is dirty, then the primary filter is damaged.

2. Inspect the primary filter for damage by looking into the filter while shining a bright light on the outside of the filter. If the primary filter is dirty, bent, or damaged, replace it.

**Note:** Holes in the filter appear as bright spots. Do not clean the primary filter.

## Installing the Filters

**Important:** To prevent engine damage, always operate the engine with both air filters and the cover installed.

1. If you are installing new filters, check each filter for shipping damage.

**Note:** Do not use a damaged filter.

2. If you are replacing the inner filter, carefully slide it into the filter body (Figure 45).
3. Carefully slide the primary filter over the safety filter (Figure 45).

**Note:** Ensure that the primary filter is fully seated by pushing on the outer rim while installing it.

**Important:** Do not press on the soft, inside area of the filter.

4. Install the air-cleaner cover and secure the latches (Figure 45).

# Servicing the Engine Oil

## Engine-Oil Specifications

**Oil Type:** Detergent oil (API service SF, SG, SH, SJ, or SL)

**Crankcase Capacity:** 1.8 L (61 oz) without oil filter; 2.1 L (71 oz) with oil filter

**Viscosity:** See the table below.

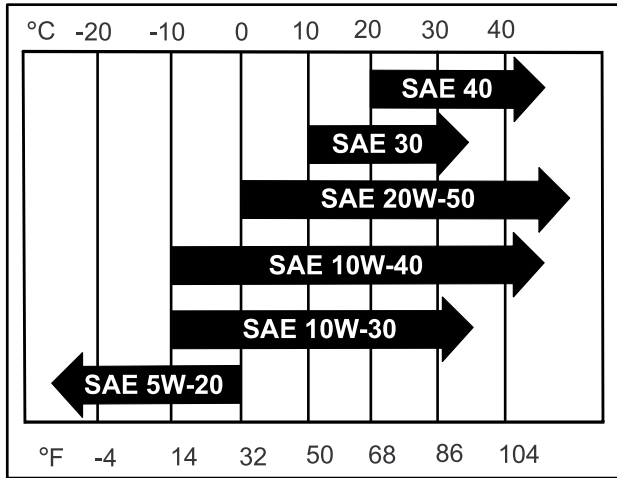

Figure 46

**Note:** Although 10W-40 engine oil is recommended for most conditions, you may need to change oil viscosity to accommodate atmospheric conditions. Using 20W-50 engine oil in higher ambient temperatures can reduce oil consumption.

## Checking the Engine-Oil Level

**Service Interval:** Before each use or daily

**Note:** Check the oil when the engine is cold.

**Important:** If you overfill or underfill the engine crankcase with oil and run the engine, you may damage the engine.

1. Park the machine on a level surface, disengage the blade-control switch (PTO), and engage the parking brake.
2. Shut off the engine, remove the key, and wait for all moving parts to stop before leaving the operating position.

**Note:** Ensure that the engine is cool so that the oil has had time to drain into the sump.

3. To keep dirt, grass clippings, etc., out of the engine, clean the area around the oil-fill cap and dipstick before removing it (Figure 47).

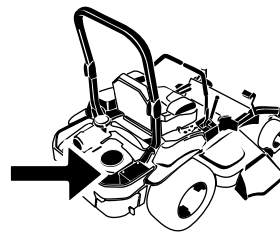

G008804  
g008804

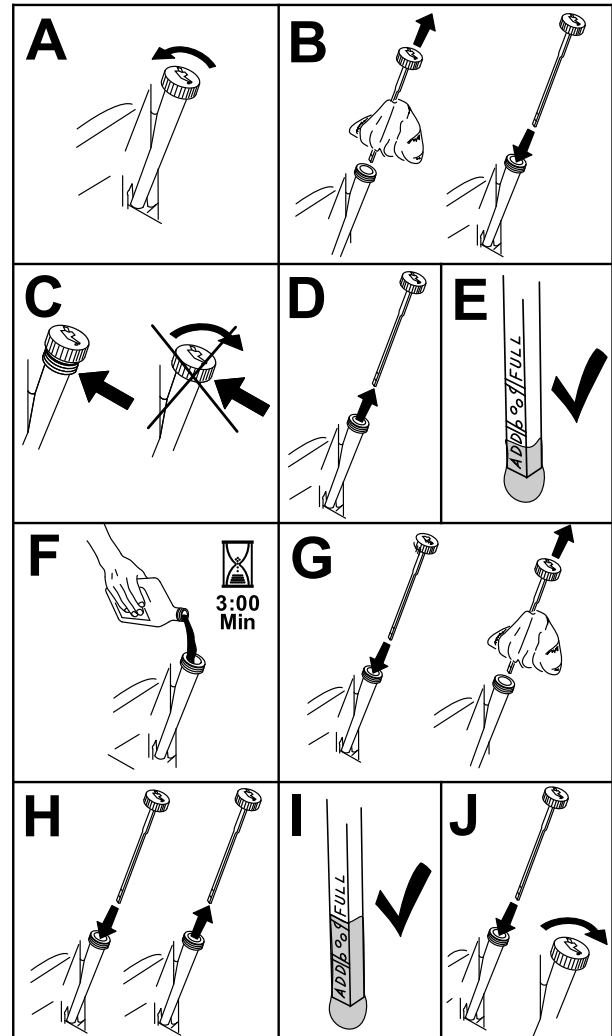

Figure 47

g194611

## Changing the Engine Oil

**Service Interval:** Every 100 hours (more often in dirty or dusty conditions).

**Note:** Dispose of the used oil at a recycling center.

1. Start the engine and let it run for 5 minutes.

**Note:** This warms the oil so that it drains better.

2. Park the machine so that the drain side is slightly lower than the opposite side to ensure that the oil drains completely.
3. Disengage the blade-control switch (PTO) and engage the parking brake.

4. Shut off the engine, remove the key, and wait for all moving parts to stop before leaving the operating position.
5. Drain the oil from the engine (Figure 48).

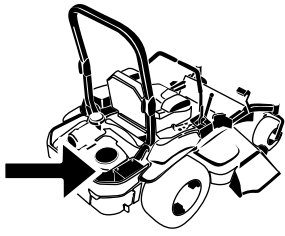

G008804  
g008804

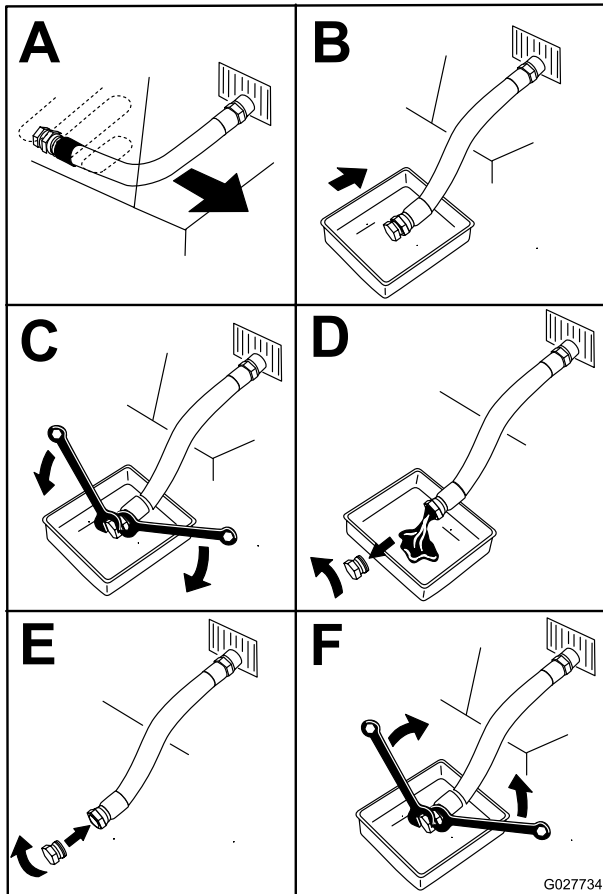

G027734  
g027734

Figure 48

6. Slowly pour approximately 80% of the specified oil into the filler tube and slowly add the additional oil to bring it to the Full mark (Figure 49).

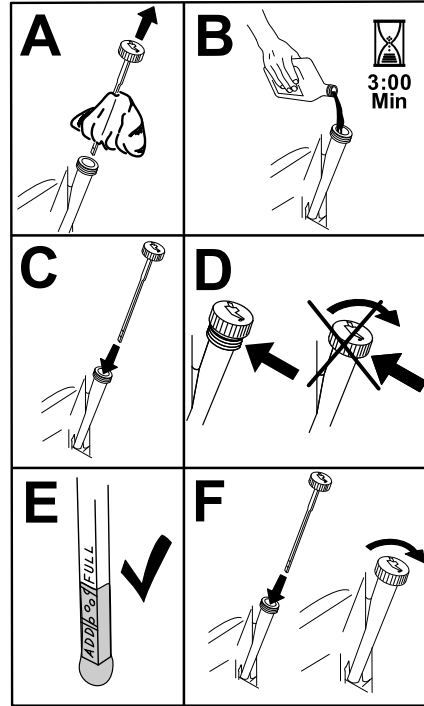

g194610

Figure 49

7. Start the engine and drive to a flat area.
8. Check the oil level again.

## Changing the Engine-Oil Filter

**Service Interval:** Every 200 hours—For Kawasaki engines—change the engine-oil filter (more often in dirty or dusty conditions).

1. Drain the oil from the engine; refer to [Changing the Engine Oil \(page 38\)](#).
2. Change the engine-oil filter ([Figure 50](#)).

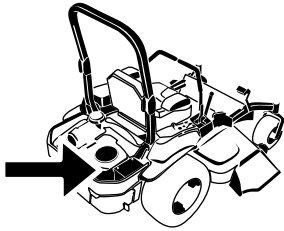

G008804  
g008804

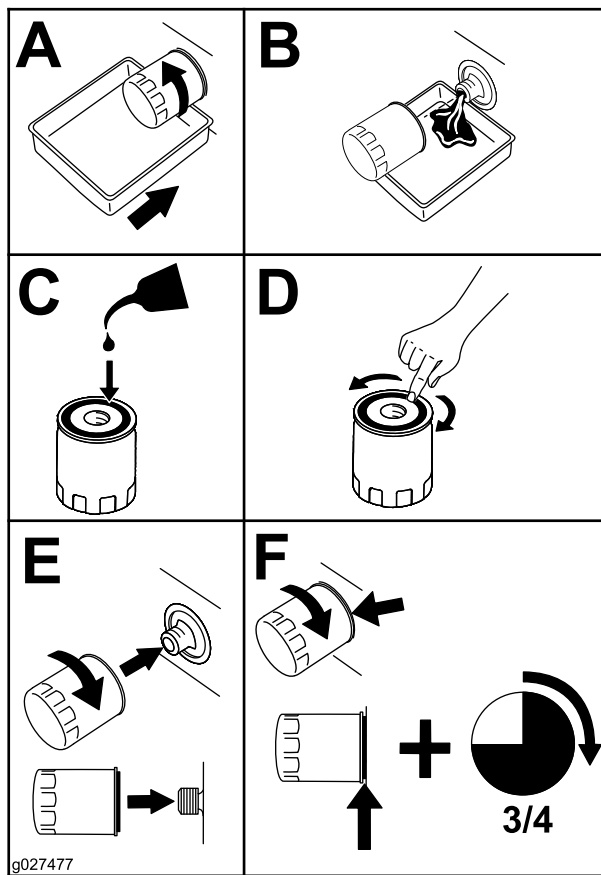

Figure 50

**Note:** Ensure that the oil-filter gasket touches the engine, and then turn the oil filter an extra 3/4 turn.

3. Fill the crankcase with the proper type of new oil; refer to [Changing the Engine Oil \(page 38\)](#).

## Servicing the Spark Plug

**Service Interval:** Every 100 hours

Ensure that the air gap between the center and side electrodes is correct before installing the spark plug. Use a spark plug wrench for removing and installing the spark plug and a gapping tool or feeler gauge to check and adjust the air gap. Install a new spark plug if necessary.

**Type of Spark Plug:** NGK® BPR4ES or equivalent

**Air Gap:** 0.75 mm (0.03 inch)

### Removing the Spark Plug

1. Park the machine on a level surface, disengage the blade-control switch, and engage the parking brake.
2. Shut off the engine, remove the key, and wait for all moving parts to stop before leaving the operating position.
3. Remove the left hydraulic-unit shroud in the order listed with [Figure 51](#). This gives you access to the front spark plug.

5. Install the left hydraulic-unit shroud (Figure 51).

### Checking the Spark Plug

**Important:** Do not clean the spark plug(s). Always replace the spark plug(s) when it has a black coating, worn electrodes, an oily film, or cracks.

If you see light brown or gray on the insulator, the engine is operating properly. A black coating on the insulator usually means the air cleaner is dirty.

Set the gap to 0.75 mm (0.03 inch).

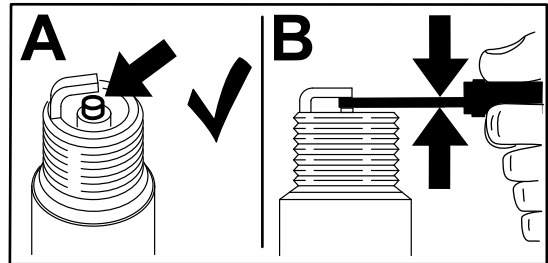

Figure 53

g206628

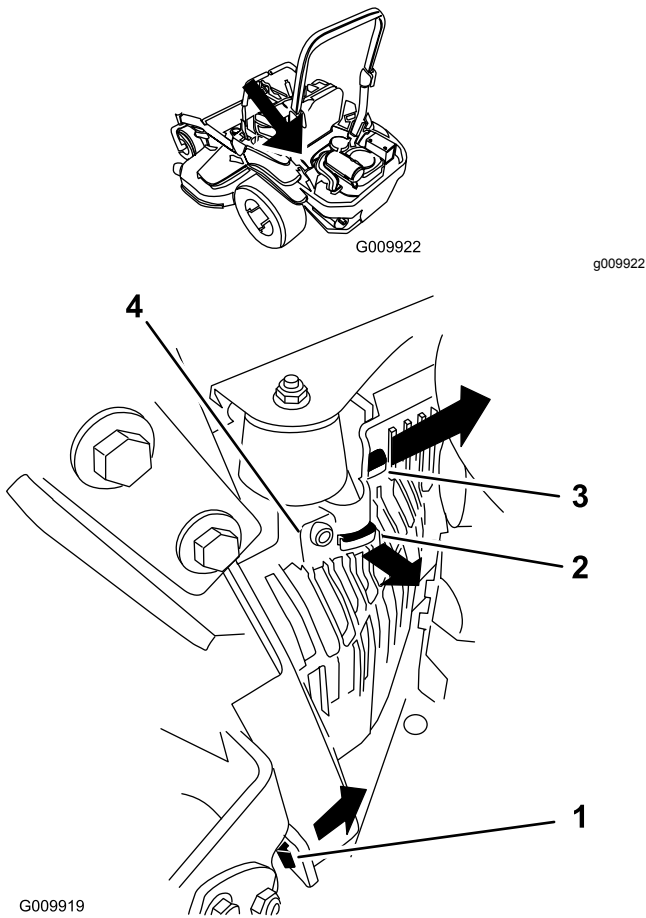

Figure 51

1. Pull this tab out to the side in the direction of the arrow
2. Pull the shroud off this frame tab in the direction of the arrow
3. Pull the shroud off this frame tab in the direction of the arrow
4. Shroud

4. Remove the spark plug.

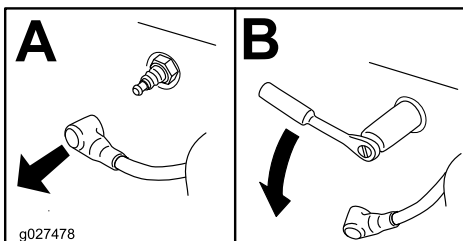
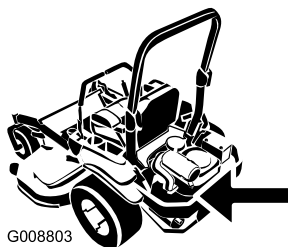

Figure 52

g027478

### Installing the Spark Plug

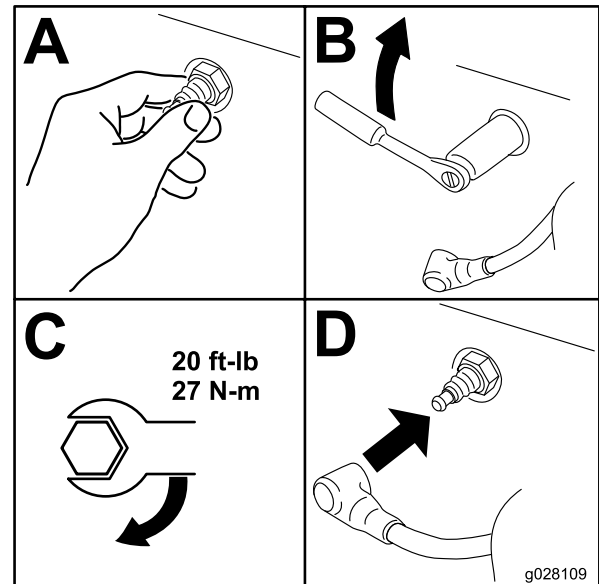

Figure 54

g028109

# Servicing a Kohler® Engine

This section is only for machines with Kohler engines. If your engine looks like the one shown in [Figure 55](#), you have a Kohler engine.

**Important:** Refer to your engine owner's manual for additional maintenance procedures.

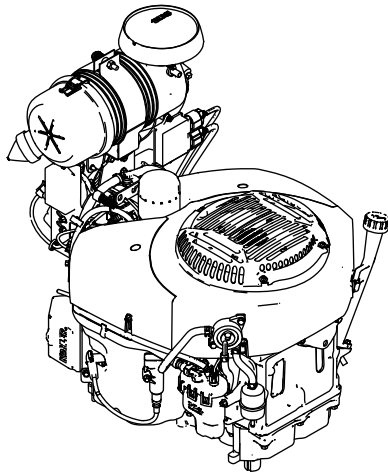

Figure 55

g230523

## Servicing the Air Cleaner

**Service Interval:** Every 150 hours—For Kohler engines—inspect the primary filter.

Every 300 hours/Yearly (whichever comes first)—For Kohler engines—replace the primary air filter (more often in dusty or sandy conditions).

Every 300 hours—For Kohler engines—check the inner air filter.

Every 600 hours—For Kohler engines—replace the inner air filter.

**Note:** Check the filters more frequently if the operating conditions are extremely dusty or sandy.

### Removing the Filters

1. Park the machine on a level surface, disengage the blade-control switch (PTO), and engage the parking brake.
2. Shut off the engine, remove the key, and wait for all moving parts to stop before leaving the operating position.
3. Release the latches on the air cleaner and pull the air-cleaner cover off the air-cleaner body ([Figure 56](#)).

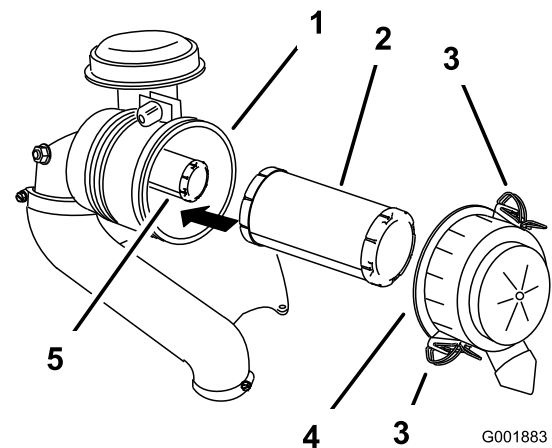

G001883

g001883

Figure 56

- |                     |                      |
|---------------------|----------------------|
| 1. Air-cleaner body | 4. Air-cleaner cover |
| 2. Primary filter   | 5. Safety filter     |
| 3. Latch            |                      |

4. Clean the inside of the air-cleaner cover with compressed air.
5. Gently slide the primary filter out of the air-cleaner body ([Figure 56](#)).

**Note:** Avoid knocking the filter into the side of the body.

6. Remove the safety filter only to replace it.

**Important:** Do not attempt to clean the safety filter. If the safety filter is dirty, then the primary filter is damaged. Replace both filters.

7. Inspect the primary filter for damage by looking into the filter while shining a bright light on the outside of the filter.

**Note:** Holes in the filter appear as bright spots. If the filter is damaged, discard it.

### Inspecting the Filters

1. Inspect the safety filter. If it is dirty, replace both the safety and primary filters.

**Important:** Do not attempt to clean the safety filter. If the safety filter is dirty, then the primary filter is damaged.

2. Inspect the primary filter for damage by looking into the filter while shining a bright light on the outside of the filter. If the primary filter is dirty, bent, or damaged, replace it.

**Note:** Holes in the filter appear as bright spots. Do not clean the primary filter.

## Installing the Filters

**Important:** To prevent engine damage, always operate the engine with both air filters and the cover installed.

1. If you are installing new filters, check each filter for shipping damage.

**Note:** Do not use a damaged filter.

2. If you are replacing the inner filter, carefully slide it into the filter body (Figure 56).
3. Carefully slide the primary filter over the safety filter (Figure 56).

**Note:** Ensure that the primary filter is fully seated by pushing on the outer rim while installing it.

**Important:** Do not press on the soft, inside area of the filter.

4. Install the air-cleaner cover and secure the latches (Figure 56).

## Servicing the Engine Oil

### Engine Oil Specifications

**Oil Type:** Detergent oil (API service SJ or higher)

**Crankcase Capacity:** 1.9 L (64 fl oz) with oil filter

**Viscosity:** See the table below.

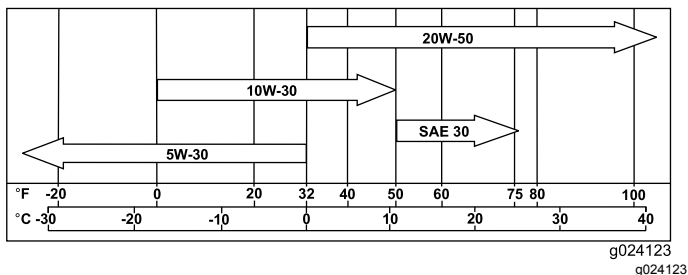

Figure 57

### Checking the Engine-Oil Level

**Service Interval:** Before each use or daily

**Note:** Check the oil when the engine is cold.

**Important:** If you overfill or underfill the engine crankcase with oil and run the engine, you may damage the engine.

1. Park the machine on a level surface, disengage the blade-control switch (PTO), and engage the parking brake.
2. Shut off the engine, remove the key, and wait for all moving parts to stop before leaving the operating position.

**Note:** Ensure that the engine is cool so that the oil has had time to drain into the sump.

3. To keep dirt, grass clippings, etc., out of the engine, clean the area around the oil-fill cap and dipstick before removing it (Figure 47).

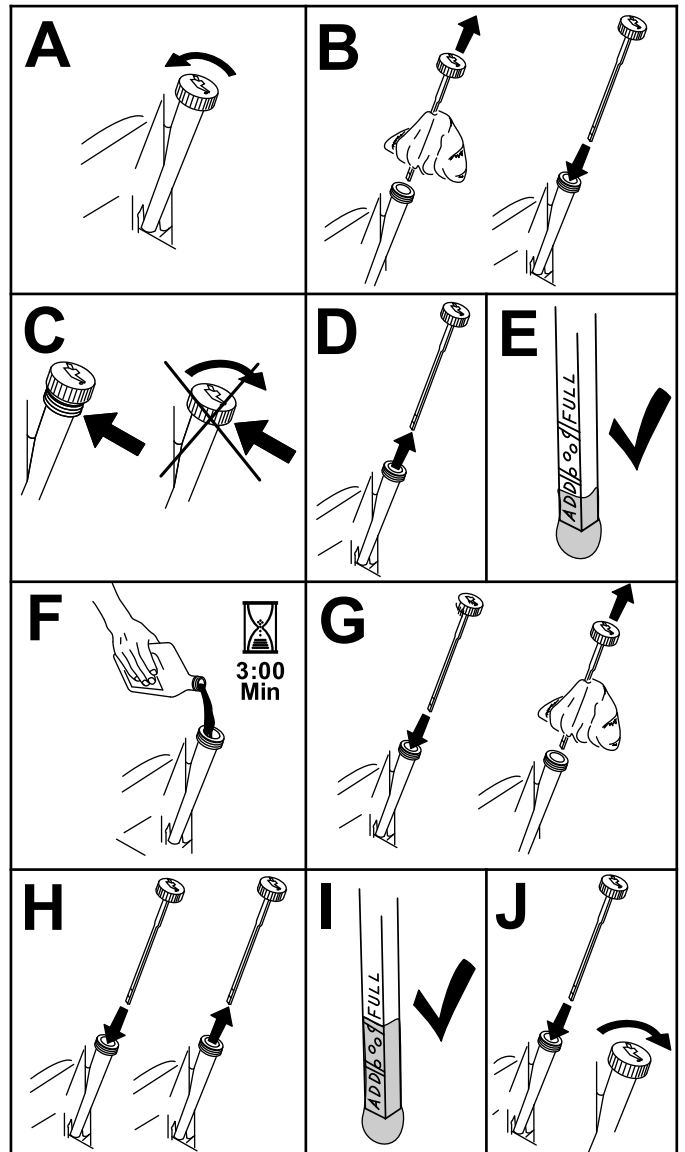

Figure 58

### Changing the Engine Oil and the Engine-Oil Filter

**Service Interval:** Every 100 hours—For Kohler engines—change the engine oil and the engine-oil filter.

**Note:** The drain plug is attached to the drain hose.

1. Park the machine so that the drain side is slightly lower than the opposite side to ensure that the oil drains completely.
2. Disengage the blade-control switch (PTO) and engage the parking brake.

3. Shut off the engine, remove the key, and wait for all moving parts to stop before leaving the operating position.
4. Drain the oil from the engine.

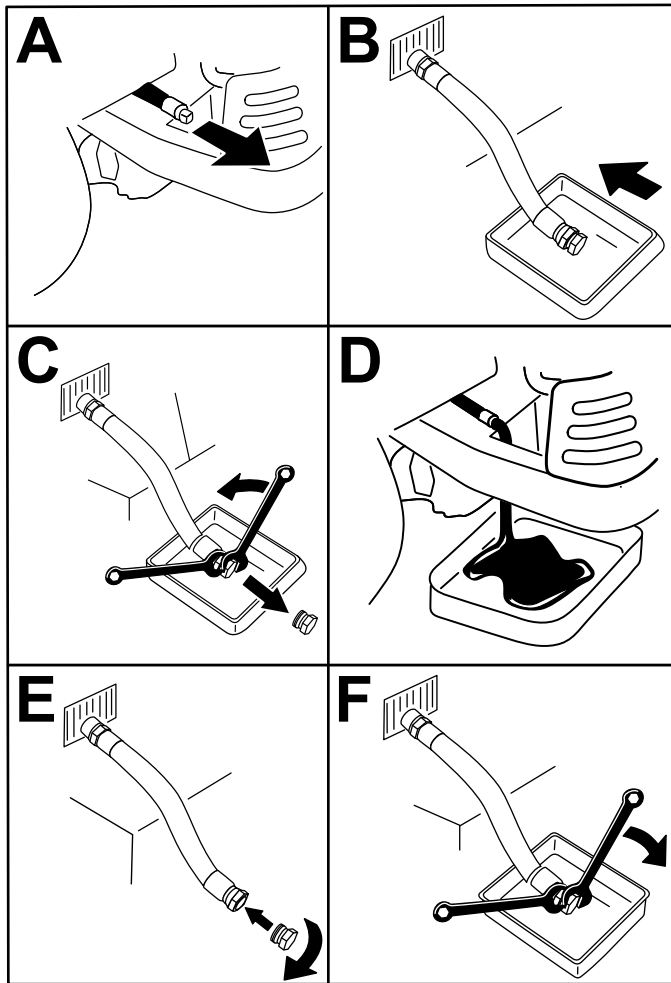

Figure 59

g027934

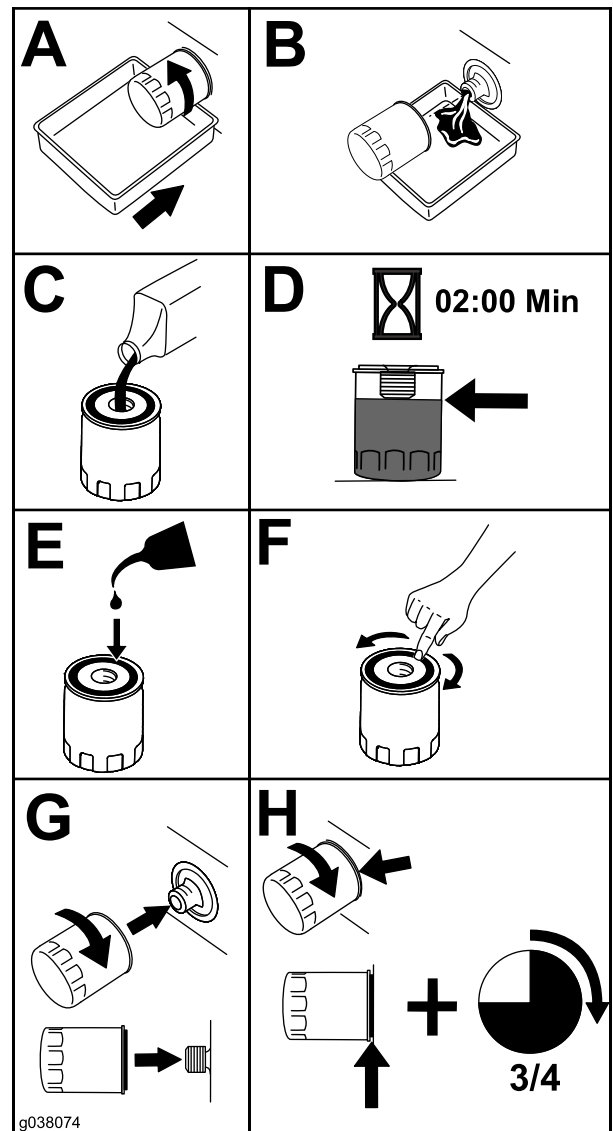

Figure 60

g038074

5. Torque the plug to 14 N·m (125 in-lb).

6. Slowly pour approximately 80% of the specified oil into the filler tube and slowly add the additional oil to bring it to the Full mark (Figure 61).

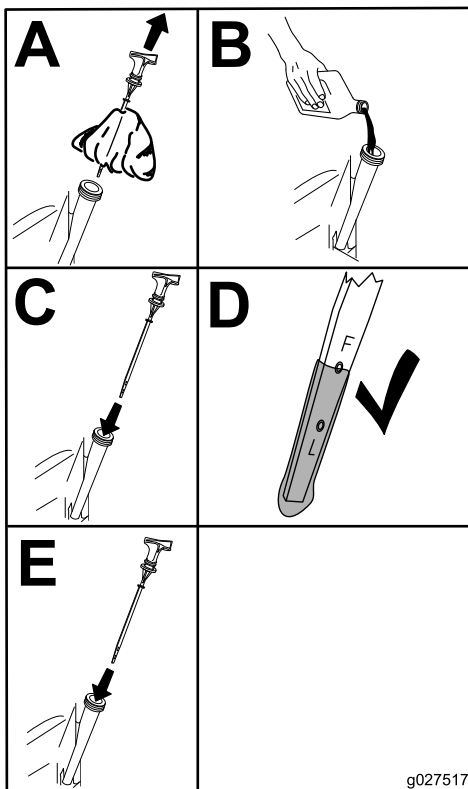
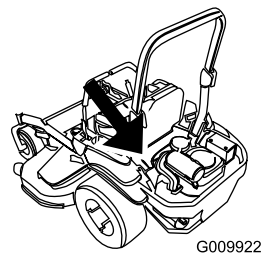
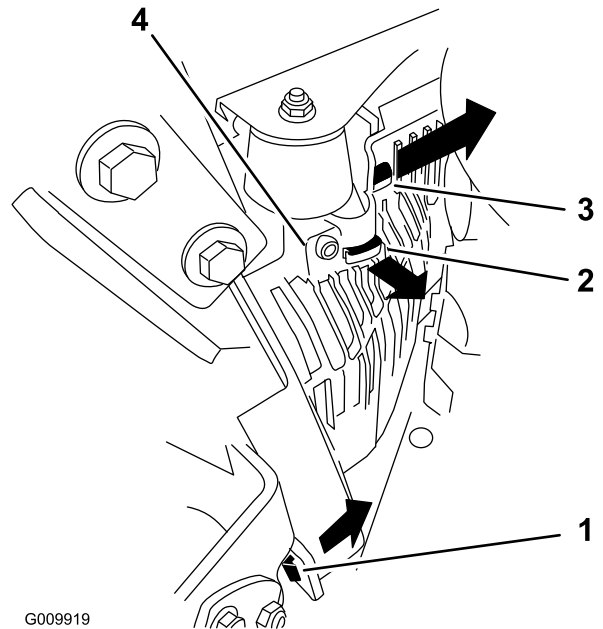

Figure 61

g027517



g009922



G009919

g009919

Figure 62

1. Pull this tab out to the side in the direction of the arrow
2. Pull the shroud off this frame tab in the direction of the arrow
3. Pull the shroud off this frame tab in the direction of the arrow
4. Shroud

7. Dispose the used oil at a recycling center.

## Servicing the Spark Plug

**Service Interval:** Every 200 hours—For Kohler engines—check the spark plug(s).

Every 500 hours—For Kohler engines—replace the spark plug(s).

**Type:** Champion XC12YC

**Air Gap:** 0.76 mm (0.03 inch)

### Removing the Spark Plug

1. Park the machine on a level surface, disengage the blade-control switch, and engage the parking brake.
2. Shut off the engine, remove the key, and wait for all moving parts to stop before leaving the operating position.
3. Remove the left hydraulic-unit shroud in the order listed with [Figure 62](#). This gives you access to the front spark plug.



g008803

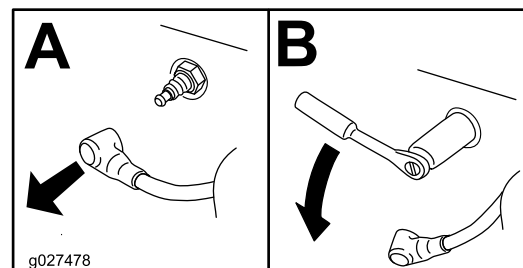

g027478

g027478

Figure 63

5. Install the left hydraulic-unit shroud (Figure 62).

## Checking the Spark Plug

**Important:** Do not clean the spark plug(s). Always replace the spark plug(s) when it has a black coating, worn electrodes, an oily film, or cracks.

If you see light brown or gray on the insulator, the engine is operating properly. A black coating on the insulator usually means the air cleaner is dirty.

Set the gap to 0.76 mm (0.03 inch).

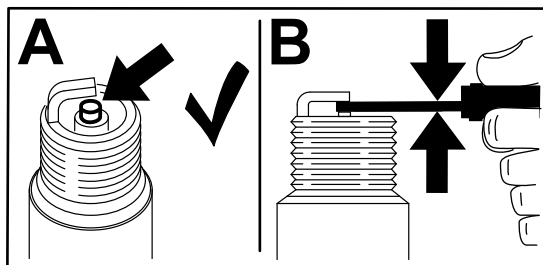

Figure 64

g206628

## Installing the Spark Plug

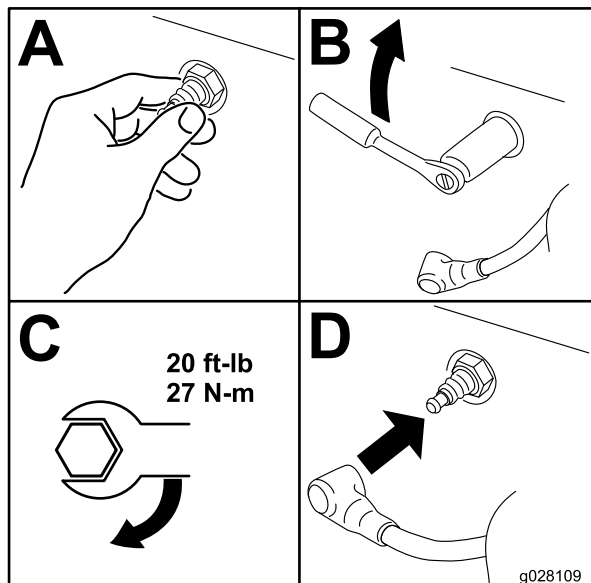

Figure 65

g028109

# Checking the Spark Arrester

## For Machines with a Spark Arrester

Service Interval: Every 50 hours

### ⚠ WARNING

Hot exhaust-system components may ignite fuel vapors even after you shut off the engine. Hot particles exhausted during engine operation may ignite flammable materials, resulting in personal injury or property damage.

**Do not refuel or run the engine unless the spark arrester is installed.**

1. Park the machine on a level surface, disengage the PTO, and engage the parking brake.
2. Shut off the engine, remove the key, and wait for all moving parts to stop before leaving the operating position.
3. Wait for the muffler to cool.
4. If you see any breaks in the screen or welds, replace the arrester.
5. If the screen is plugged, remove the arrester, shake loose particles out of the arrester, and clean the screen with a wire brush (soak the screen in solvent if necessary).
6. Install the arrester on the exhaust outlet.

# Fuel System Maintenance

## ⚠ WARNING

Fuel-system components are under high pressure. The use of improper components can result in system failure, fuel leakage, and possible explosion.

Use only approved fuel lines and fuel filters.

## Servicing the Electronic Fuel-Injection System

This machine contains an electronic fuel-injection system. It controls the fuel flow under different operating conditions.

The electronic-control unit (ECU) continuously monitors the operation of the EFI system.

If a problem or fault within the system is detected, the LED status light illuminates. The MIL is the red light located on the right side of the hour meter.

Once the light illuminates, make initial troubleshooting checks; refer to the LED status light section under [Troubleshooting \(page 72\)](#).

If these checks do not correct the problem, further diagnosis and servicing by an Authorized Service Dealer is necessary.

## Replacing the Low-Pressure Fuel Filter

**Service Interval:** Every 200 hours/Yearly (whichever comes first)

The fuel filter is located near the engine on the front or rear side of the engine.

1. Park the machine on a level surface, disengage the blade-control switch, and engage the parking brake.
2. Shut off the engine, remove the key, and wait for all moving parts to stop before leaving the operating position.
3. Wait for the machine to cool down.
4. Close the fuel-shutoff valve under the seat ([Figure 66](#)).

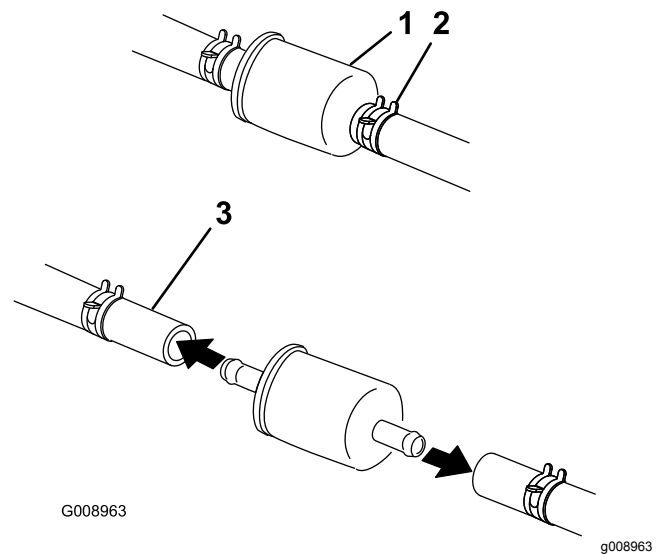

Figure 66

1. Fuel filter
2. Hose clamp
3. Fuel line

5. Squeeze the ends of the hose clamps together and slide them away from the filter ([Figure 66](#)).
6. Remove the filter from the fuel lines.
7. Install a new filter and move the hose clamps close to the filter ([Figure 66](#)).
8. Open the fuel-shutoff valve.

**Important:** Install the fuel line hoses and secure with plastic ties the same as they were originally installed at the factory to keep the fuel line away from components that can cause fuel line damage.

## Servicing the High-Pressure Fuel Filter

Do not attempt to service the high-pressure fuel filter. The high-pressure filter is integrated within the fuel-pump module. The fuel filter and other components inside the fuel-pump module are not serviceable.

**Important:** Do not attempt to open the fuel-pump module.

Ensure that an Authorized Service Dealer replaces the fuel-pump module with the high-pressure fuel filter.

## Servicing the Fuel Tank

Do not attempt to drain the fuel tank. Ensure that an Authorized Service Dealer drains the fuel tank and services any components of the fuel system.

# Electrical System Maintenance

## Electrical System Safety

- Disconnect the battery before repairing the machine. Disconnect the negative terminal first and the positive last. Connect the positive terminal first and the negative last.
- Charge the battery in an open, well-ventilated area, away from sparks and flames. Unplug the charger before connecting or disconnecting the battery. Wear protective clothing and use insulated tools.

## Servicing the Battery

Service Interval: Monthly

## Removing the Battery

### ⚠ WARNING

Battery terminals or metal tools could short against metal machine components causing sparks. Sparks can cause the battery gasses to explode, resulting in personal injury.

- When removing or installing the battery, do not allow the battery terminals to touch any metal parts of the machine.
- Do not allow metal tools to short between the battery terminals and metal parts of the machine.

### ⚠ WARNING

Incorrectly removing the cables from battery could damage the machine and cables, causing sparks. Sparks can cause the battery gasses to explode, resulting in personal injury.

- Always disconnect the negative (black) battery cable before disconnecting the positive (red) cable.
- Always connect the positive (red) battery cable before connecting the negative (black) cable.

1. Park the machine on a level surface, disengage the blade-control switch (PTO), and engage the parking brake.

2. Shut off the engine, remove the key, and wait for all moving parts to stop before leaving the operating position.
3. Remove the battery as shown in [Figure 67](#).

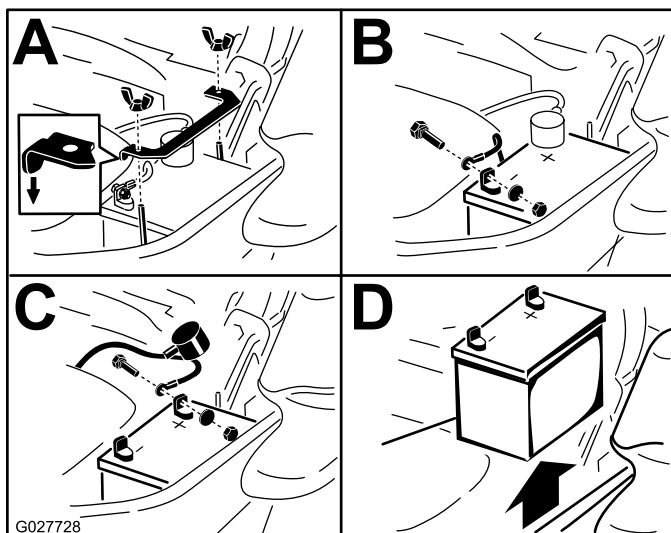

Figure 67

# Charging the Battery

## ⚠ WARNING

Charging the battery produces gasses that can explode.

Never smoke near the battery and keep sparks and flames away from the battery.

**Important:** Always keep the battery fully charged (1.265 specific gravity). This is especially important to prevent battery damage when the temperature is below 0°C (32°F).

1. Remove the battery from the chassis; refer to [Removing the Battery \(page 48\)](#).
2. Charge the battery for 10 to 15 minutes at 25 to 30 A or for 30 minutes at 10 A.

**Note:** Do not overcharge the battery.

3. When the battery is fully charged, unplug the charger from the electrical outlet, then disconnect the charger leads from the battery posts ([Figure 68](#)).
4. Install the battery in the machine and connect the battery cables; refer to [Installing the Battery \(page 49\)](#).

**Note:** Do not run the machine with the battery disconnected; electrical damage may occur.

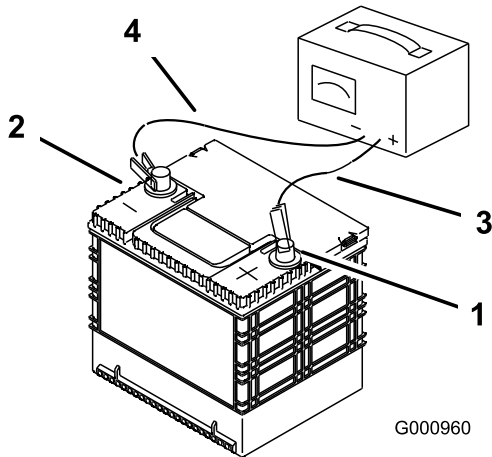

Figure 68

- |                              |                           |
|------------------------------|---------------------------|
| 1. Positive (+) battery post | 3. Red (+) charger lead   |
| 2. Negative (-) battery post | 4. Black (-) charger lead |

# Installing the Battery

**Note:** Position the battery in the tray with the terminal posts opposite from the hydraulic tank ([Figure 67](#)).

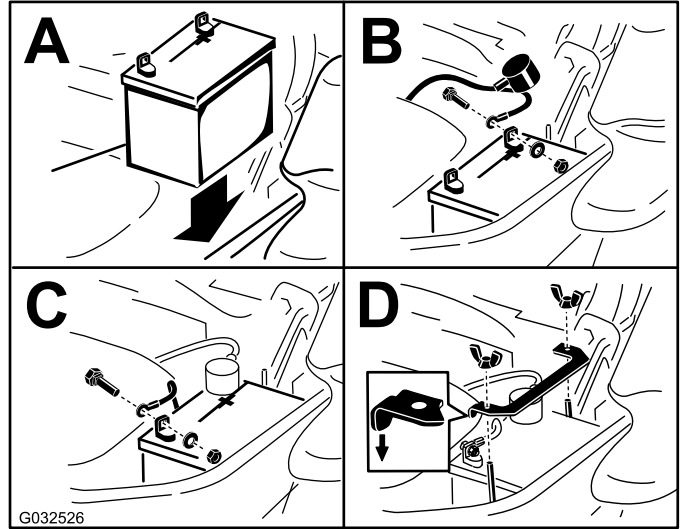

Figure 69

## Servicing the Fuses

The electrical system is protected by fuses. It requires no maintenance, however, if a fuse blows check the component/circuit for a malfunction or short. The fuses are located on the console to the right of the seat (Figure 70).

To replace the fuses, remove the cover, pull out on the fuse to remove it, and install a new fuse.

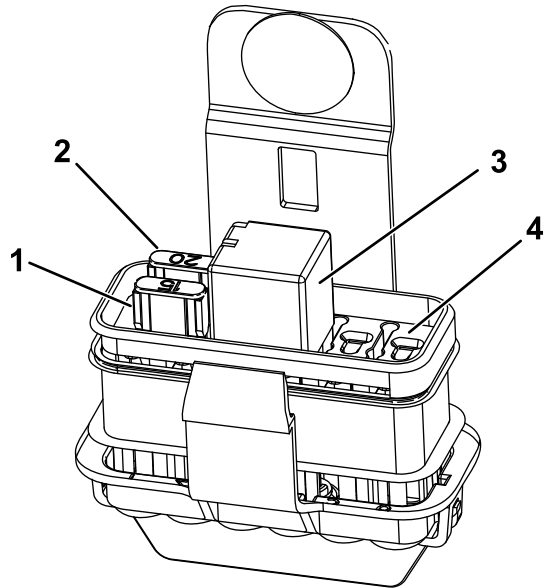

Figure 70

g231345

- |                    |                |
|--------------------|----------------|
| 1. Auxiliary, 15 A | 3. Start relay |
| 2. Main, 20 A      | 4. Open        |

## Drive System Maintenance

### Checking the Seat Belt

**Service Interval:** Before each use or daily

Inspect the seat belt for wear, cuts, and proper operation of the retractor and buckle. Replace the seat belt if it is damaged.

### Checking the Roll-Bar Knobs

**Service Interval:** Before each use or daily

#### **⚠ WARNING**

To avoid injury or death from rollover, keep the roll bar in the fully raised, locked position and use the seat belt.

**Ensure that the seat is secured to the machine.**

- Check that both the mounting hardware and the knobs are in good working condition.
- Make sure that the knobs are fully engaged with the roll bar in the raised position.

**Note:** The upper hoop of the roll bar may need to be pushed forward or pulled rearward to fully engage both knobs (Figure 71 and Figure 72).

# Adjusting the Tracking

1. Disengage the blade-control switch (PTO).
2. Drive to an open flat area, move the motion-control levers to the NEUTRAL-LOCK position.
3. Move the throttle midway between fast and slow.
4. Move both motion-control levers all the way forward until they both hit the stops in the T-slot.
5. Check which way the machine tracks.
  - If it tracks to the right, loosen the bolts and adjust the left stop plate rearward on the left T-slot until the machine tracks straight (Figure 73).
  - If it tracks to the left, loosen the bolts and adjust the right stop plate rearward on the right T-slot until the machine tracks straight (Figure 73).
6. Tighten the stop plate (Figure 73).

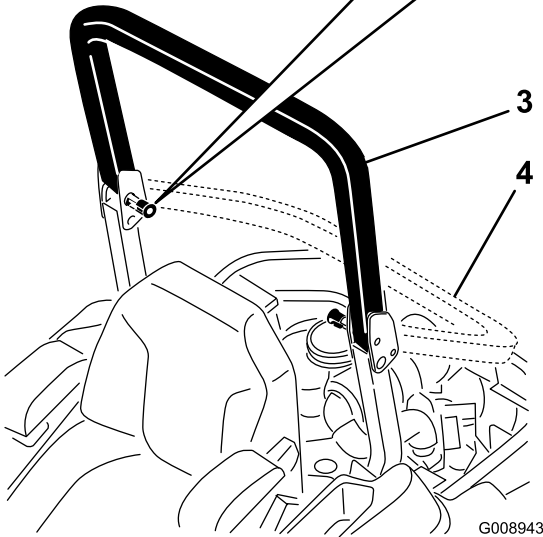
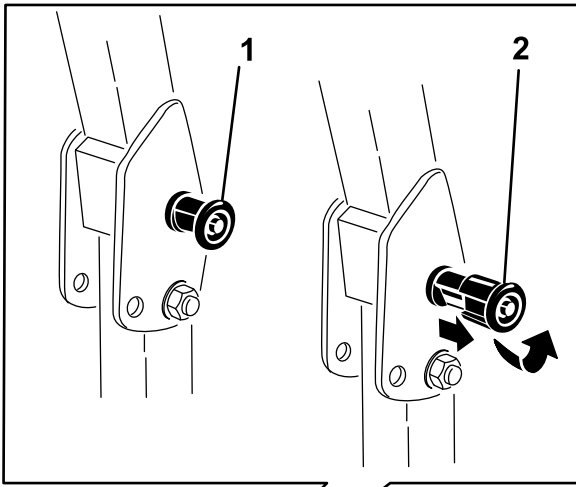

**Figure 71**

- |   |  |
|---|--|
| 1. Roll bar in the upright position                     | 4. Rotate the roll-bar knob 90 degrees.    |
| 2. Roll-bar knob in the latched position                | 5. Roll-bar knob in the unlatched position |
| 3. Pull the roll-bar knob out and rotate it 90 degrees. | 6. Roll bar in the folded position         |

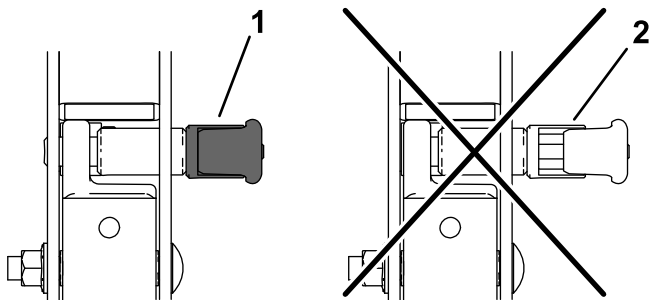

**Figure 72**

- |            |   |
|------------|---|
| 1. Engaged | 2. Partially engaged—do not operate with the roll bar in this position. |
|------------|---|

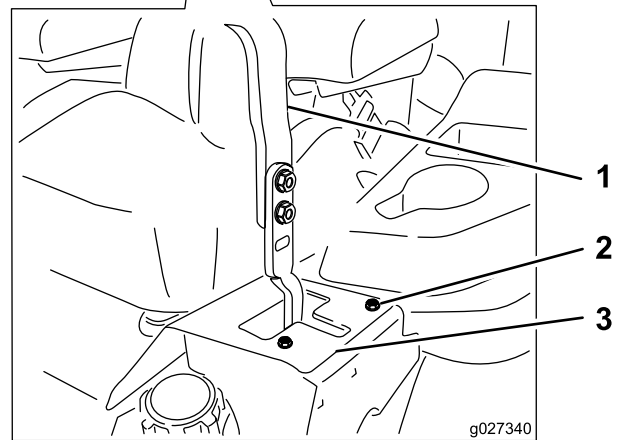
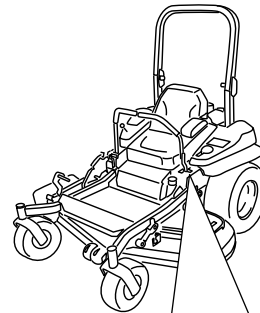

**Figure 73**  
Left control lever shown

- |                  |               |
|------------------|---------------|
| 1. Control lever | 3. Stop plate |
| 2. Bolt          |               |

# Checking the Tire Pressure

**Service Interval:** Every 40 hours

Maintain the air pressure in the rear tires at 103 kPa (15 psi). Uneven tire pressure can cause uneven cut. Check the tires when they are cold, to get the most accurate pressure reading.

**Note:** The front tires are semi-pneumatic tires and does not require air pressure maintenance.

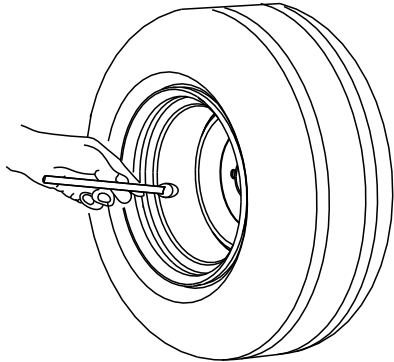

G001055

Figure 74

g001055

---

**Note:** Do not add any type of tire liner or foam fill material to the tires.

# Checking the Wheel Lug Nuts

Check and torque the wheel lug nuts to 122 to 129 N·m (90 to 95 ft-lb).

# Checking the Wheel-Hub Slotted Nut

**Service Interval:** After the first 100 hours

Every 500 hours

Check and ensure that the torque of the slotted nut is 286 to 352 N·m (211 to 260 ft-lb).

**Note:** Do not use anti-seize compound on wheel hub.

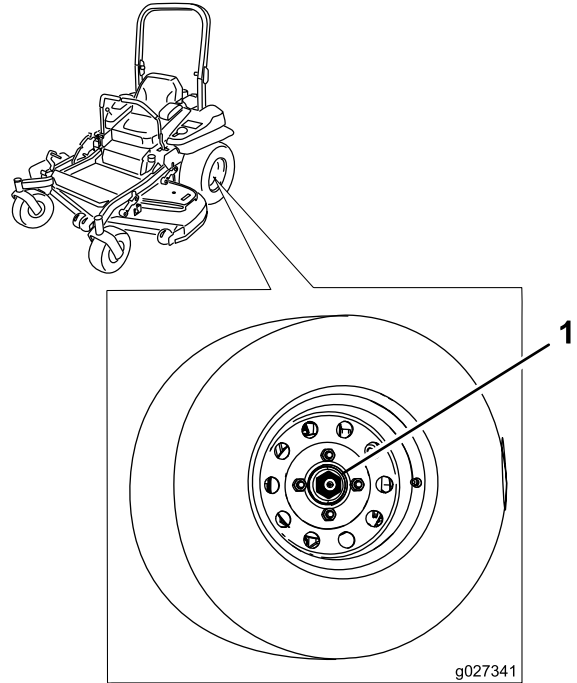

g027341

Figure 75

g027341

1. Slotted nut

---

# Adjusting the Caster-Pivot Bearing

**Service Interval:** Every 500 hours/Yearly (whichever comes first)

1. Park the machine on a level surface, disengage the blade-control switch (PTO), and engage the parking brake.
2. Shut off the engine, remove the key, and wait for all moving parts to stop before leaving the operating position.
3. Remove the dust cap from caster and tighten the locknut (Figure 76).
4. Tighten the locknut until the spring washers are flat, and then back off a 1/4 turn to properly set the preload on the bearings (Figure 76).

**Important:** Make sure that the spring washers are installed correctly as shown in Figure 76.

5. Install the dust cap (Figure 76).

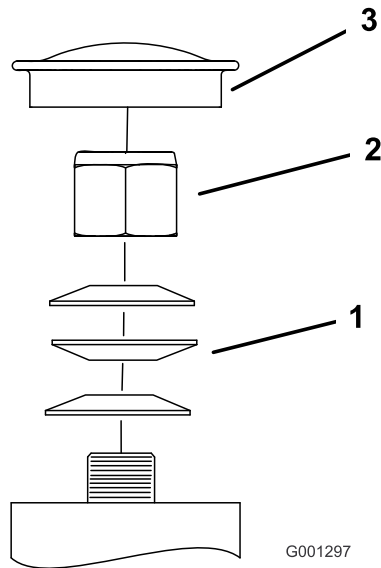

Figure 76

- |                   |             |
|-------------------|-------------|
| 1. Spring washers | 3. Dust cap |
| 2. Locknut        |             |

## Removing the Clutch Shim

1. Park the machine on a level surface, disengage the blade-control switch (PTO), and engage the parking brake.
2. Shut off the engine, remove the key, and wait for all moving parts to stop before leaving the operating position.
3. Using an air compressor, blow out any debris from under the brake pole and around the brake spacers (Figure 78).

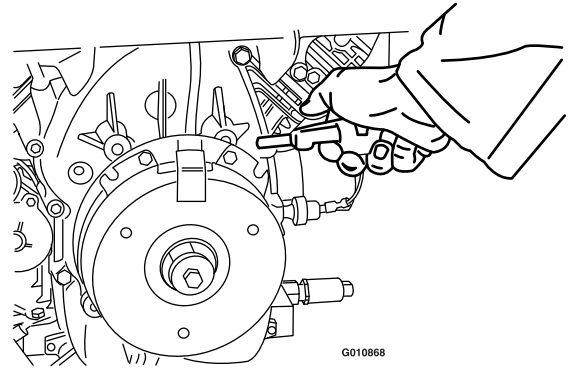

Figure 78

## Using the Clutch Shim

Some later model year units have been built with clutches that contain a brake shim. When the clutch brake has worn to the point where the clutch no longer engages consistently, you can remove the shim to extend the clutch life.

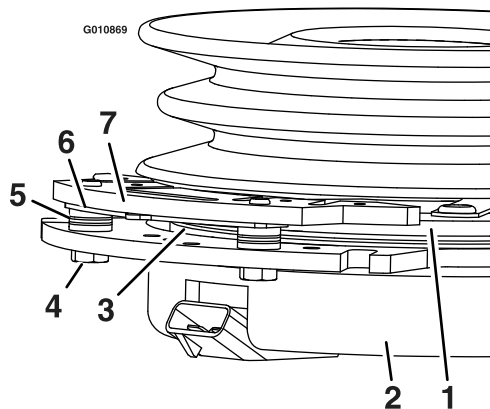
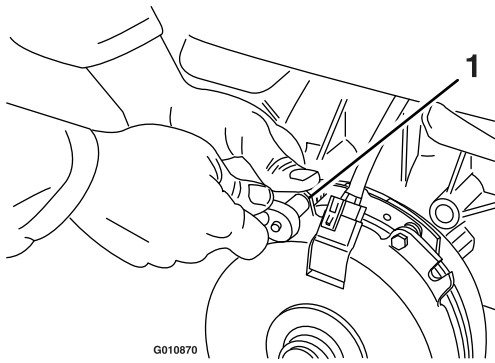

Figure 77

- |                        |                 |
|------------------------|-----------------|
| 1. Armature            | 5. Brake spacer |
| 2. Field shell         | 6. Re-gap shim  |
| 3. Rotor               | 7. Brake pole   |
| 4. Brake-mounting bolt |                 |

4. Check the condition of the wire-harness leads, connectors, and terminals.
  - Note:** Clean or repair as necessary.
5. Verify that 12 V is present at the clutch connector when the blade-control switch (PTO) switch is engaged.
6. Measure the gap between the rotor and armature. If the gap is greater than 1 mm (0.04 inch), do the following steps:
  - A. Loosen both brake-mounting bolts 1/2 to 1 full turn as shown in Figure 79.

**Note:** Do not remove the brake pole from the field shell/armature. The brake pole has worn to match the armature and needs to continue to match after you remove the shim to ensure proper brake torque.

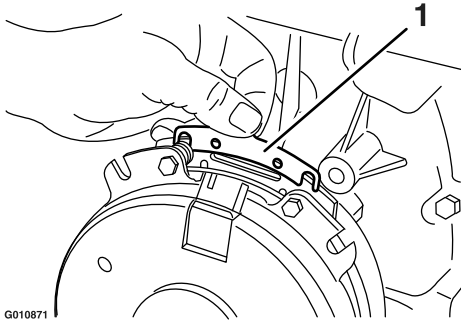

**Figure 79**

1. Brake-mounting bolt

- B. Using needle-nose pliers, or by hand, hold the tab and remove the shim (Figure 80).

**Note:** Do not discard the shim until the clutch is functioning properly.

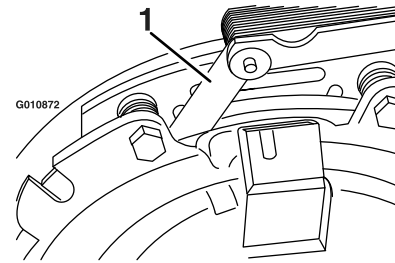

**Figure 80**

1. Shim

- C. Using a pneumatic line, blow out any debris from under the brake pole and around the brake spacers.
- D. Torque each bolt (M6 x 1) to 12.3 to 13.7 N·m (9.5 to 10.5 ft-lb).
- E. Using a 0.25 mm (0.01 inch) thick feeler gauge, verify that a gap is present between the rotor and the armature face on both sides of the brake pole as shown in Figure 81 and Figure 82.

**Note:** Due to the way the rotor and the armature faces wear (peaks and valleys) it is sometimes difficult to measure the gap accurately.



**Figure 81**

1. Feeler gauge

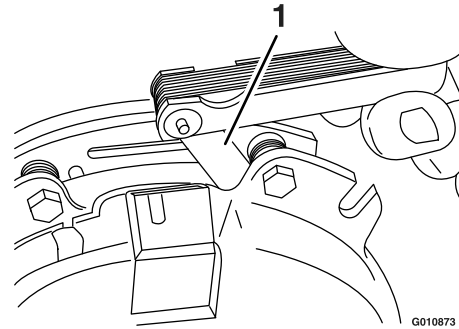

**Figure 82**

1. Feeler gauge

- If the gap is less than 0.25 mm (0.01 inch), then install the shim; refer to [Using the Clutch Shim \(page 53\)](#).
- If the gap is sufficient, proceed to the safety check in step F.

- F. Perform the following safety check:

- i. Sit on the seat and start the engine.
- ii. Make sure that the blades do not engage with the blade-control switch (PTO) in the OFF position, and that the clutch is disengaged.

If the clutch does not disengage, install the shim again; refer to [Using the Clutch Shim \(page 53\)](#).

- iii. Engage and disengage the blade-control switch (PTO) 10 consecutive times to ensure that the clutch is functioning properly.

# Cooling System Maintenance

## Cleaning the Engine Screen and Engine-Oil Cooler

**Service Interval:** Before each use or daily

Remove any buildup of grass, dirt, or other debris from the oil cooler and the engine screen (Figure 83).

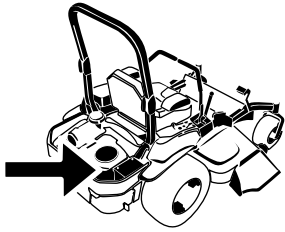

G008804  
g008804

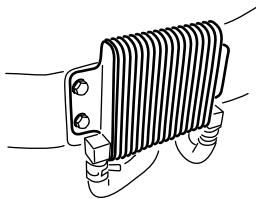

G009191  
g009191

Figure 83

Remove any buildup of grass, dirt, or other debris from the engine screen. This helps ensure adequate cooling and correct engine speed and reduces the possibility of overheating and mechanical damage to the engine (Figure 80).

## Cleaning the Engine-Cooling Fins and Shrouds

**Service Interval:** Every 100 hours/Yearly (whichever comes first)

1. Park the machine on a level surface, disengage the blade-control switch (PTO), and engage the parking brake.
2. Shut off the engine, remove the key, and wait for all moving parts to stop before leaving the operating position.
3. Remove the air-intake screen, the recoil starter, and the fan housing (Figure 84).
4. Clean the debris and grass from the engine parts.
5. Install the air-intake screen, the recoil starter, and the fan housing (Figure 84).

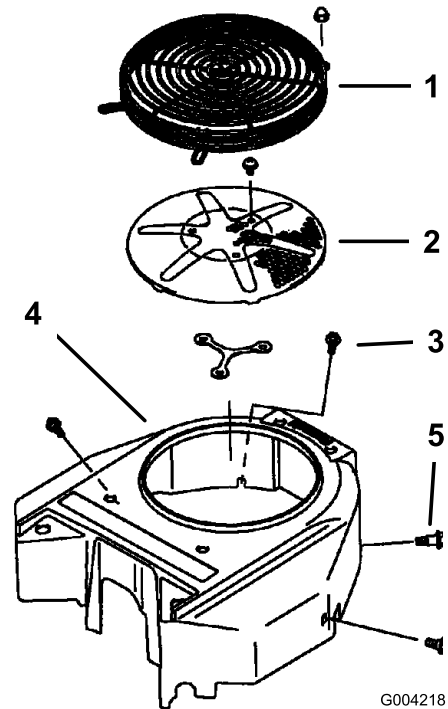

G004218

g004218

Figure 84

- |                             |                |
|-----------------------------|----------------|
| 1. Engine guard             | 4. Fan housing |
| 2. Engine air-intake screen | 5. Screw       |
| 3. Bolt                     |                |

# Checking and Cleaning the Hydraulic-Unit Shrouds

**Service Interval:** Before each use or daily

1. Disengage the blade-control switch (PTO) and engage the parking brake.
2. Shut off the engine, remove the key, and wait for all moving parts to stop before leaving the operating position.
3. Move the seat forward.
4. Clean the debris and grass from the hydraulic-unit shrouds ([Figure 85](#)).
5. Position the seat.

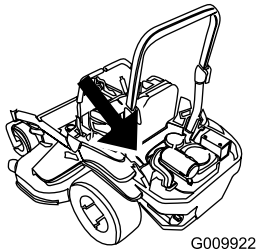

g009922

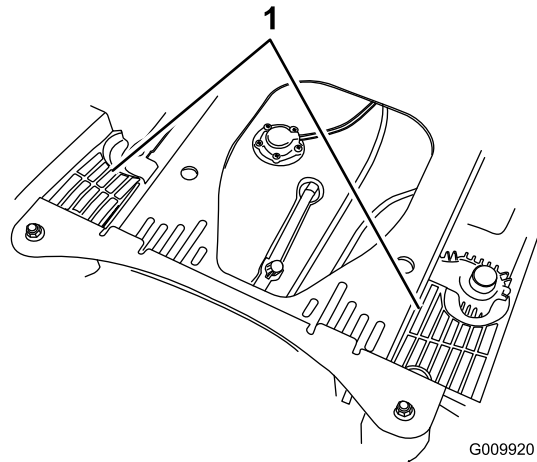

g009920

**Figure 85**

1. Hydraulic-unit shrouds

# Brake Maintenance

## Adjusting the Parking Brake

**Service Interval:** After the first 100 hours

Every 500 hours thereafter

**Note:** Perform this procedure at the recommended service interval or when a brake component has been removed or replaced.

1. Park the machine on a level surface, disengage the blade-control switch (PTO), and engage the parking brake.
2. Shut off the engine, remove the key, and wait for all moving parts to stop before leaving the operating position.
3. Raise the back of the machine and support the machine with jack stands.

### **CAUTION**

Raising the machine for service or maintenance relying solely on mechanical or hydraulic jacks could be dangerous. The mechanical or hydraulic jacks may not be enough support or may malfunction allowing the machine to fall, which could cause injury.

**Do not rely solely on mechanical or hydraulic jacks for support. Use adequate jack stands or equivalent support.**

4. Remove the rear tires from the machine.
5. Remove any debris from the brake area.
6. Rotate the drive-wheel release handle to the released position; refer to [Using the Drive-Wheel-Release Valves](#) (page 28).
7. Check to see if there is a visible gap between the L-bracket and the linkage stop ([Figure 86](#)).

# Belt Maintenance

## Inspecting the Belts

**Service Interval:** Every 50 hours

Replace the belt if it is worn. The signs of a worn belt include squealing while the belt is rotating; the blades slipping while cutting grass; and frayed edges, burn marks, and cracks on the belt.

## Replacing the Mower Belt

1. Park the machine on a level surface, disengage the blade-control switch (PTO), and engage the parking brake.
2. Shut off the engine, remove the key, and wait for all moving parts to stop before leaving the operating position.
3. Lower the mower to the 76 mm (3 inch) height-of-cut.
4. Remove the belt covers (Figure 87).

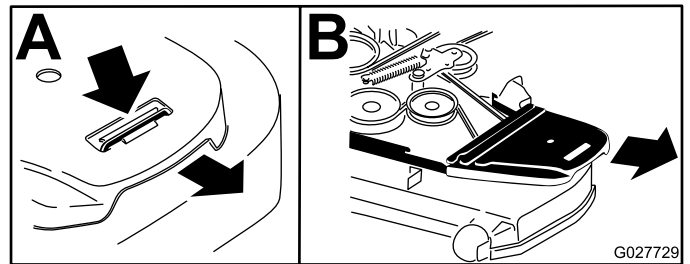

**Figure 87**

1. Push the tab down
2. Remove the belt cover

5. Use a ratchet in the square hole in the idler arm to remove tension on the idler spring (Figure 88).
6. Remove the belt from the mower-deck pulleys.
7. Remove the belt guide on the spring-loaded idler arm (Figure 88).
8. Remove the existing belt.
9. Install the new belt around the mower pulleys and the clutch pulley under the engine (Figure 88).

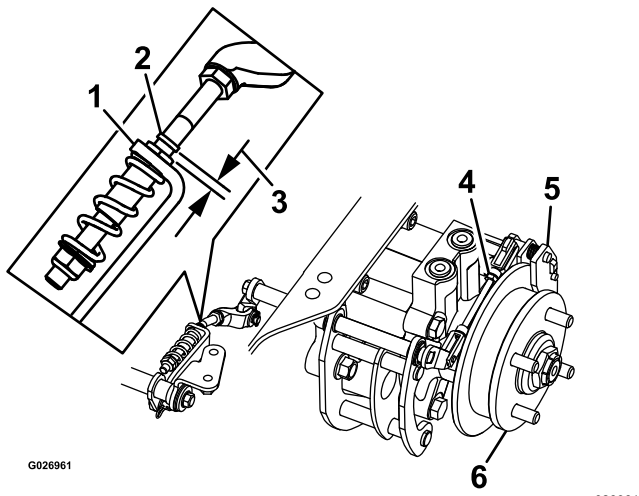

**Figure 86**  
Left Side Shown

1. L-bracket
  2. Linkage stop
  3. Gap
  4. Rear linkage assembly
  5. Caliper
  6. Wheel hub
- 
8. Disengage the parking brake, the lever should be in the down position.
  9. Turn the wheel hub by hand in both directions relative to the caliper; the wheel hub should move freely between the caliper.
  10. If a gap is needed or the wheel hub does not move freely:
    - A. Disengage the parking brake.
    - B. Disconnect and fine-tune the rear linkage assembly:
      - Shorten the link to create a gap.
      - Lengthen the link to allow wheel hub movement.
    - C. Connect the rear linkage assembly.
  11. Engage the parking brake and check the gap.
  12. Repeat steps 8 through 12 until a visible gap is achieved and the wheel hub rotates freely.
  13. Repeat this procedure for the brake on the opposite side.
  14. Rotate the drive-wheel release handle to the operating position; refer to [Using the Drive-Wheel-Release Valves \(page 28\)](#).
  15. Install the rear tires and torque the lug nuts; refer to [Checking the Wheel Lug Nuts \(page 52\)](#).
  16. Remove the jack stands.

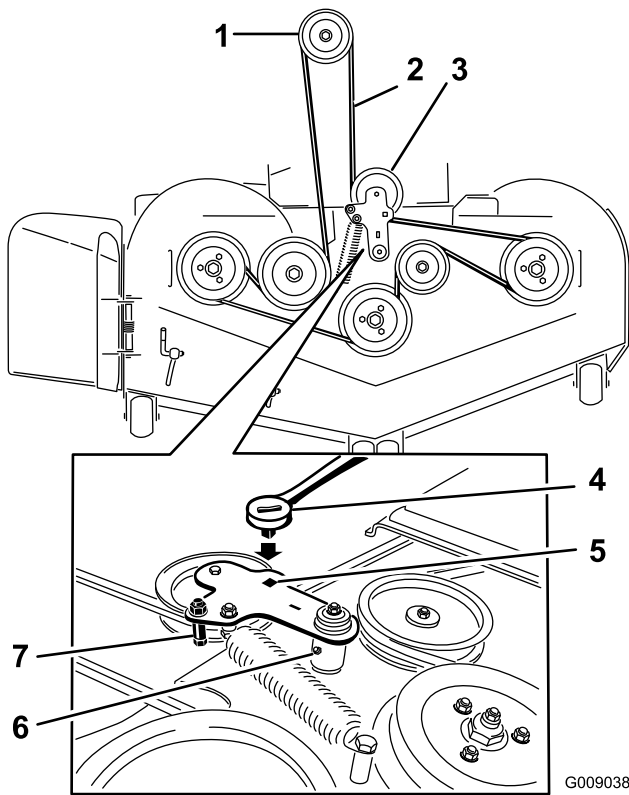

Figure 88

G009038  
g009038

- |                               |   |
|-------------------------------|---|
| 1. Clutch pulley              | 5. Square hole in the idler arm for the ratchet |
| 2. Mower belt                 | 6. Idler-grease fitting                         |
| 3. Spring-loaded idler pulley | 7. Belt guide                                   |
| 4. Ratchet                    |   |

10. Install the belt guide on the idler arm (Figure 88).
11. Using the ratchet in the square hole, install the idler spring (Figure 88).

**Note:** Make sure that the spring ends are seated in the anchor grooves.

12. Install the belt covers (Figure 89).

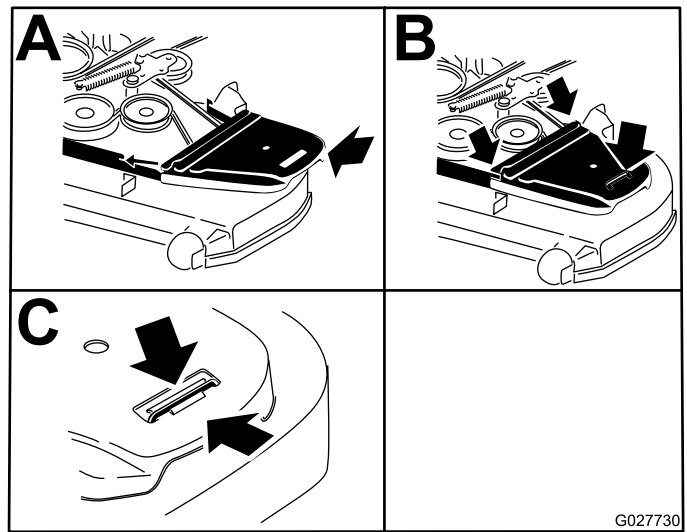

G027730  
g027730

Figure 89

1. Position the belt cover
2. Slide the belt cover under the side catches
3. Ensure that the tab is under the metal catch

## Replacing the Hydraulic Pump-Drive Belt

1. Park the machine on a level surface, disengage the blade-control switch (PTO), and engage the parking brake.
2. Shut off the engine, remove the key, and wait for all moving parts to stop before leaving the operating position.
3. Remove the mower belt; refer to [Replacing the Mower Belt \(page 57\)](#).
4. Raise the machine and support it with jack stands (Figure 90).

# Controls System Maintenance

## Adjusting the Control-Handle Position

There are 2 height positions for the control levers—high and low. Remove the bolts to adjust the height for the operator.

1. Park the machine on a level surface, disengage the blade-control switch (PTO), and engage the parking brake.
2. Shut off the engine, remove the key, and wait for all moving parts to stop before leaving the operating position.
3. Loosen the bolts and flange nuts installed in the levers ([Figure 91](#)).
4. Align the levers in the front-to-rear position by bringing the levers together to the NEUTRAL position, and slide them until they are aligned, then tighten the bolts ([Figure 92](#)).

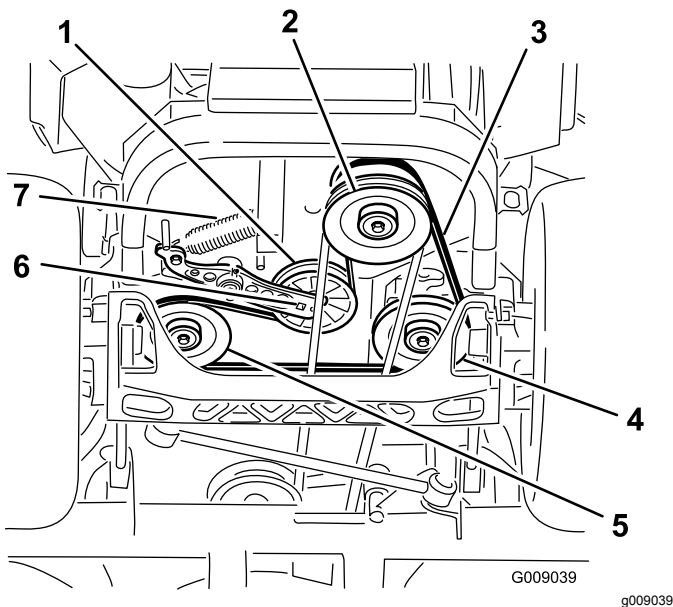

**Figure 90**

- |                                |                                 |
|--------------------------------|---------------------------------|
| 1. Idler pulley                | 5. Left hydraulic-pump pulley   |
| 2. Clutch pulley               | 6. Square hole in the idler arm |
| 3. Pump-drive belt             | 7. Idler spring                 |
| 4. Right hydraulic-pump pulley |                                 |

5. Use a ratchet in the square hole in the idler arm to remove the idler spring ([Figure 90](#)).
6. Unhook the idler spring from the frame ([Figure 90](#)).
7. Remove the belt from the hydraulic-unit-drive pulleys and the engine pulley.
8. Install the new belt around engine pulley and the 2 drive pulleys.
9. Using a ratchet in the square hole in the idler arm, install the idler spring to the frame ([Figure 90](#)).
10. Install the mower belt; refer to [Replacing the Mower Belt \(page 57\)](#).

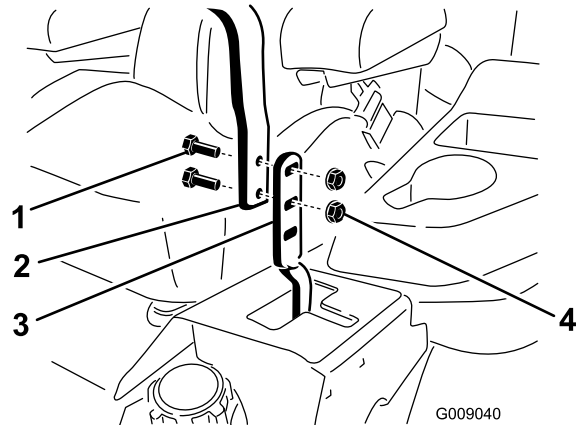

**Figure 91**

- |           |                  |
|-----------|------------------|
| 1. Bolt   | 3. Control lever |
| 2. Handle | 4. Nut           |

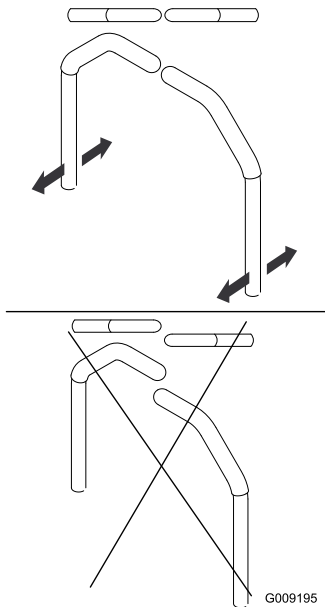

Figure 92

G009195

5. If the ends of the levers hit against each other, refer to [Adjusting the Motion-Control Neutral-Lock Pivot](#) (page 61).
6. Repeat to adjust the control levers.

## Adjusting the Motion-Control Linkage

Located on either side of the machine, below the seat, are the pump-control linkages. Rotating the end nut with a 1/2-inch deep socket wrench allows fine tuning adjustments so that the machine does not move in neutral. Any adjustments should be made for neutral positioning only.

### **⚠ WARNING**

**The engine must be running and the drive wheels turning so that you can perform the adjustments. Contact with moving parts or hot surfaces may cause personal injury.**

**Keep your fingers, hands, and clothing clear of rotating components and hot surfaces.**

1. Disengage the blade-control switch (PTO), move the motion-control levers to the NEUTRAL-LOCK position, and engage the parking brake.
2. Shut off the engine, remove the key, and wait for all moving parts to stop before leaving the operating position.
3. Push the deck-lift pedal, and remove the height-of-cut pin.

4. Lower deck to the ground.
  5. Raise the rear of machine up and support it with jack stands (or equivalent support).
- Note:** Raise the machine just high enough to allow the drive wheels to turn freely.
6. Remove the electrical connection from the seat safety switch, located under the bottom cushion of the seat.

**Note:** The switch is a part of the seat assembly.

7. **Temporarily** install a jumper wire across the terminals in the connector of the main wire harness.
8. Start the engine and run it at full throttle and disengage the brake.

**Note:** Before starting the engine, ensure that the parking brake is engaged and that the motion-control levers are out. You do not have to be in the seat.

9. Run the machine for at least 5 minutes with the drive levers at full forward speed to bring the hydraulic fluid up to the operating temperature.

**Note:** The motion-control levers must be in neutral while making any necessary adjustments.

10. Bring the motion-control levers into the NEUTRAL position.
11. Adjust the pump control rod lengths by rotating the double nuts on the rod in the appropriate direction until the wheels slightly creep in reverse ([Figure 93](#)).

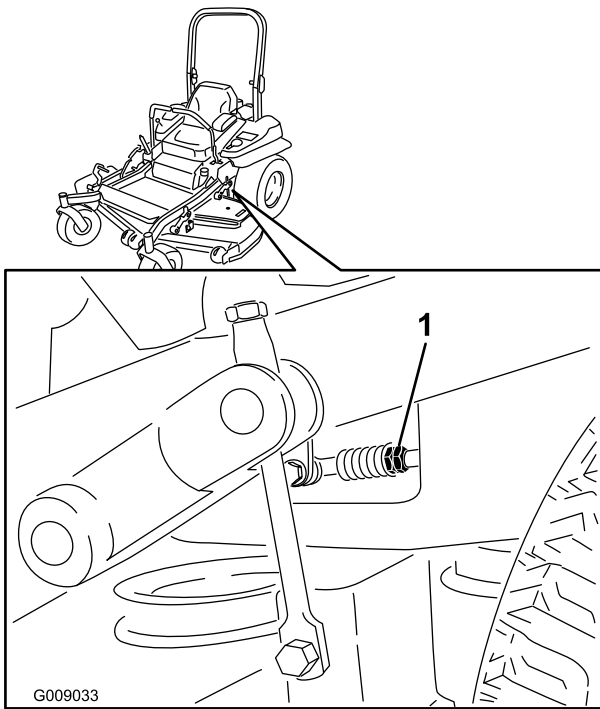

**Figure 93**

1. Double nuts

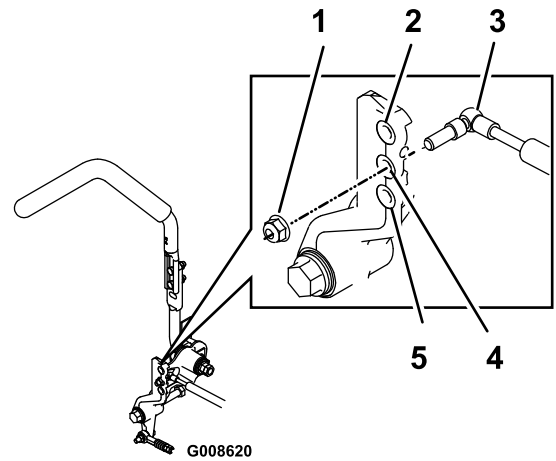

**Figure 94**

Right Motion Control Shown

1. Torque the locknut to 23 N·m (17 ft·lb). The bolt must protrude past the end of the locknut after torquing.
2. Most resistance (firmest feel)
3. Damper
4. Medium resistance (medium feel)
5. Least resistance (softest feel)

12. Move the motion-control levers to the REVERSE position and while applying slight pressure to the lever, allow the reverse-indicator springs to bring the levers back to neutral.

**Note:** The wheels must stop turning or slightly creep in reverse.

13. Shut off the machine.
14. Remove the jumper wire from the wire harness and plug the connector into the seat switch.
15. Remove the jack stands.
16. Raise the deck and install the height-of-cut pin.
17. Check that the machine does not creep in neutral with the park brakes disengaged.

## Adjusting the Motion-Control Damper

You can adjust the top damper-mounting bolt to obtain the desired motion-control lever resistance. Refer to [Figure 94](#) for mounting options.

## Adjusting the Motion-Control Neutral-Lock Pivot

You can adjust the flanged nut to obtain the desired motion-control lever resistance when moving it to the NEUTRAL-LOCK position. See [Figure 95](#) for adjustment options.

1. Loosen the jam nut.
2. Tighten or loosen the flanged nut to the desired feel.
  - For more resistance, tighten the flanged nut.
  - For less resistance, loosen the flanged nut
3. Tighten the jam nut.

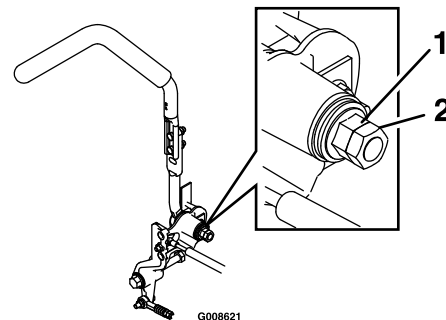

**Figure 95**

1. Flanged nut
2. Jam nut

# Hydraulic System Maintenance

## Hydraulic System Safety

- Seek immediate medical attention if fluid is injected into skin. Injected fluid must be surgically removed within a few hours by a doctor.
- Ensure that all hydraulic-fluid hoses and lines are in good condition and all hydraulic connections and fittings are tight before applying pressure to the hydraulic system.
- Keep your body and hands away from pinhole leaks or nozzles that eject high-pressure hydraulic fluid.
- Use cardboard or paper to find hydraulic leaks.
- Safely relieve all pressure in the hydraulic system before performing any work on the hydraulic system.

## Servicing the Hydraulic System

### Hydraulic-Fluid Specifications

**Hydraulic-Fluid Type:** Toro® HYPR-OIL™ 500 hydraulic fluid or Mobil® 1 15W-50.

**Important:** Use the specified fluid. Other fluids could damage the hydraulic system.

**Each Hydraulic-System Fluid Capacity:** 1.5 L (52 oz) per side with filter change

### Checking the Hydraulic Fluid

**Service Interval:** Every 50 hours—Check the hydraulic-fluid level.

1. Park the machine on a level surface, disengage the blade-control switch (PTO), and engage the parking brake.
2. Shut off the engine, remove the key, and wait for all moving parts to stop before leaving the operating position.
3. Allow the engine and the hydraulic system to cool for 10 minutes.

**Note:** The fluid level on the dipstick is incorrect when the fluid is checked and the machine is hot.

4. Move the seat forward.
5. Clean the area around the dipsticks of hydraulic-system reservoirs (Figure 96).

6. Remove 1 dipstick from the hydraulic reservoir (Figure 96).
  7. Wipe the dipstick off and thread the dipstick into the reservoir.
  8. Remove the dipstick and look at the end (Figure 96).
- Important:** Do not overfill the hydraulic units with fluid, as damage may occur. Do not run the machine with fluid below the add mark.
9. If the fluid level is at the add mark, slowly pour only enough fluid into the hydraulic reservoir to raise the level to the full or H line.
  10. Install the dipstick.
  11. Repeat the procedure for the opposite dipstick.

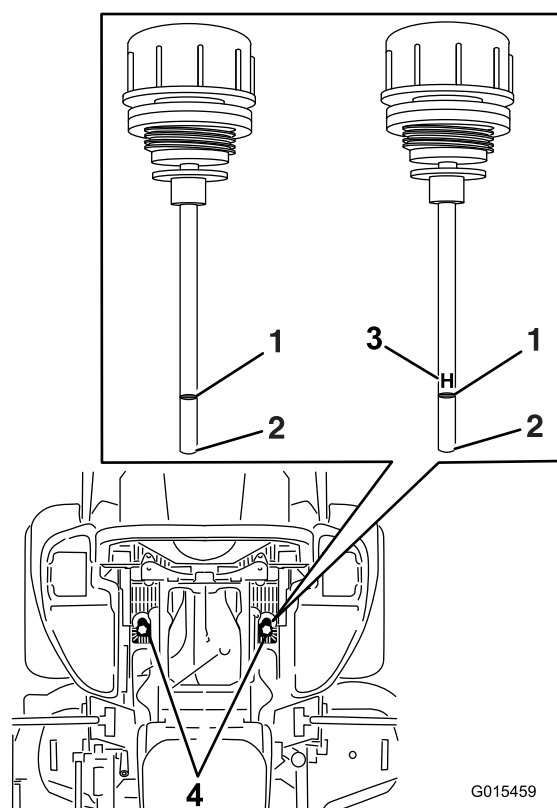

**Figure 96**

Either dipstick is used in the machine

1. Full
2. Add
3. H —means high level
4. Dipstick locations under seat

# Replacing the Hydraulic Fluid and Filters

**Service Interval:** After the first 250 hours—Change the hydraulic filters and hydraulic fluid when using any type of fluid.

Every 250 hours—Change the hydraulic filters and hydraulic fluid when using Mobil® 1 fluid (more often in dirty or dusty conditions).

Every 500 hours—Change the hydraulic filters and hydraulic fluid when using Toro® HYPR-OIL™ 500 hydraulic fluid (more often in dirty or dusty conditions).

To replace the hydraulic fluid, the filters need to be removed. Replace both at the same time; refer to [Hydraulic-Fluid Specifications \(page 62\)](#) for the fluid specifications.

1. Park the machine on a level surface, disengage the blade-control switch, and engage the parking brake.
2. Shut off the engine, remove the key, and wait for all moving parts to stop before leaving the operating position.
3. Raise the machine and support it with jack stands ([Figure 97](#)).

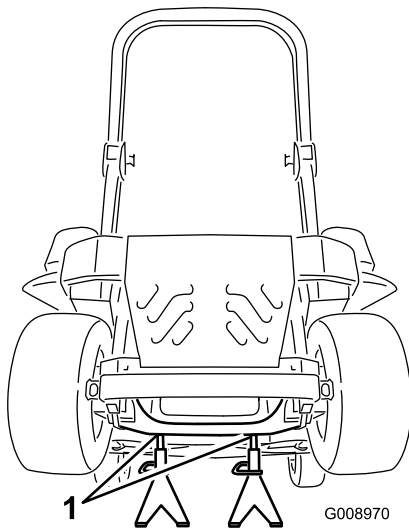

**Figure 97**

1. Jack stands

4. Remove both the mower belt and the pump-drive belt; refer to [Replacing the Mower Belt \(page 57\)](#) and [Replacing the Hydraulic Pump-Drive Belt \(page 58\)](#).

**Note:** This prevents fluid from getting on the belts.

5. Place a drain pan under the filter, remove the old filter, and wipe the surface clean ([Figure 98](#)).

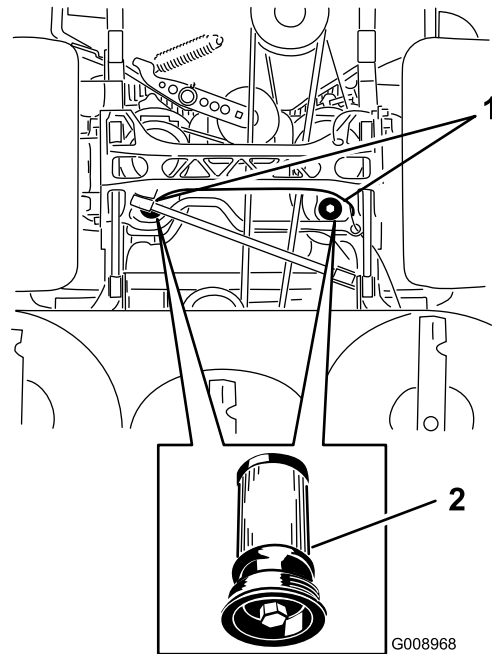

**Figure 98**

Bottom view of the machine

1. Filter locations
2. Hydraulic filter

6. Apply a thin coat of hydraulic fluid to the rubber gasket on the replacement filter ([Figure 98](#)).
7. Install the replacement hydraulic filter.
8. Install the pump-drive belt and the mower belt.
9. Remove the jack stands and lower the machine ([Figure 97](#)).
10. Add fluid to the hydraulic reservoir and check for any leaks.
11. Clean up any spilled fluid.
12. Start the engine and let it run for about 2 minutes to purge air from the system.
13. Shut off the engine and check for leaks.
14. Check the fluid level while the fluid is cold.
15. If required, add fluid to the hydraulic reservoir.

**Note:** Do not overfill.

# Mower Deck Maintenance

## Leveling the Mower Deck

### Leveling the Deck

1. Park the machine on a level surface, disengage the blade-control switch (PTO), and engage the parking brake.
2. Shut off the engine, remove the key, and wait for all moving parts to stop before leaving the operating position.
3. Check the tire pressure in the drive tires; refer to [Checking the Tire Pressure \(page 52\)](#).
4. Position the transport lock in the latching position.
5. Push the deck-lift pedal all the way forward and the deck latches at the 14 cm (5-1/2 inches) transport position ([Figure 99](#)).

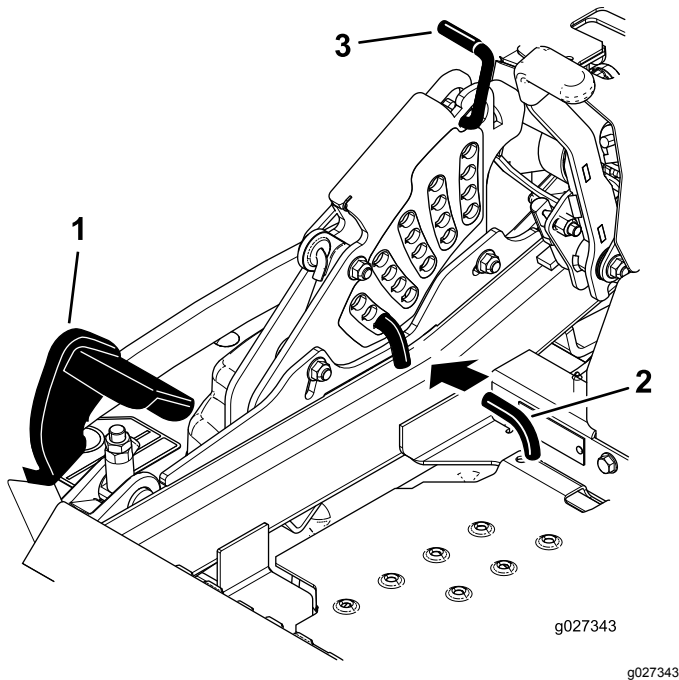

Figure 99

1. Deck-lift pedal
2. Height-of-cut pin
3. Transport lock

6. Insert the height-adjustment pin into the 7.6 cm (3 inches) cutting-height location.
7. Release the transport lock and allow the deck to lower to the cutting height.
8. Raise the discharge chute.

9. On both sides of the deck, measure from the level surface to the front tip of the blade (Position A) as shown in [Figure 100](#).

**Note:** The measurement should read 7.6 mm (3 inches)

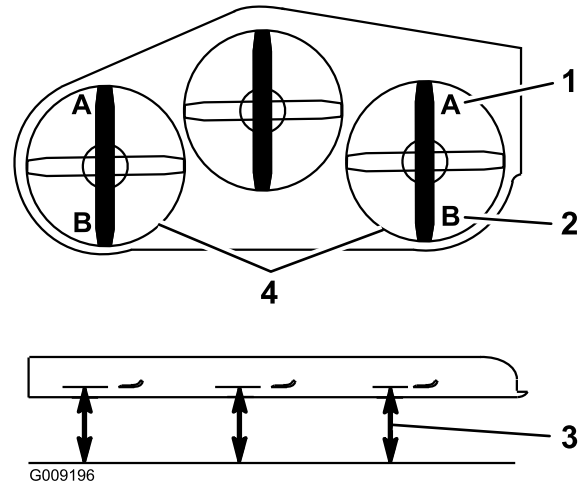

Figure 100

1. 7.6 cm (3 inch) at position A is correct
2. 8.3 cm (3-1/4 inch) at position B is correct
3. Measure here from the blade tip to the hard surface
4. Measure at position A and B on both sides

10. Fine-tune the adjustment nut on the front deck-lift assembly by turning it ([Figure 101](#)).

**Note:** To increase the height, turn the adjustment nut clockwise; to decrease the height, turn the nut counterclockwise.

**Note:** If the front deck links do not have enough adjustment to achieve accurate cut height, the single-point adjustment can be utilized to gain more adjustment.

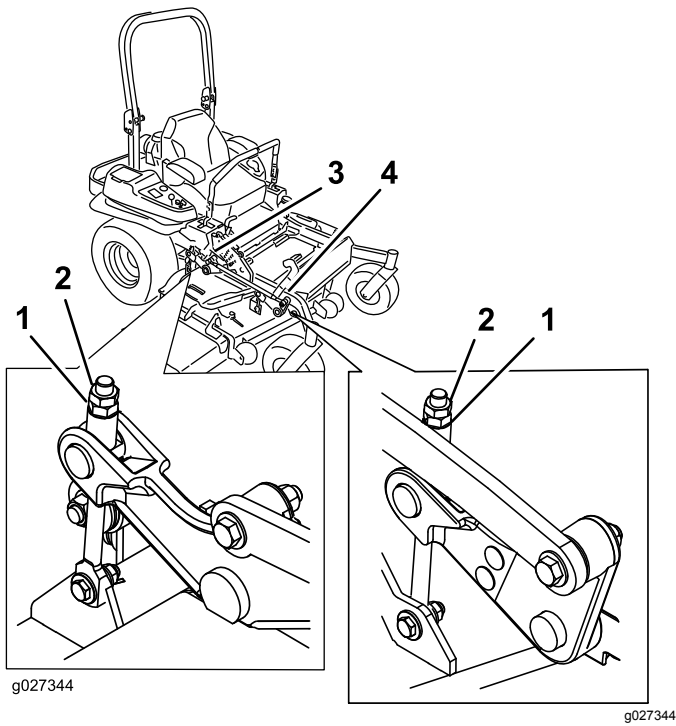

**Figure 101**

- |                   |                          |
|-------------------|--------------------------|
| 1. Adjustment nut | 3. Rear deck adjustment  |
| 2. Jam nut        | 4. Front deck adjustment |

11. To adjust the single-point system, loosen the 2 bolts at the bottom of the height-of-cut plate (Figure 102).

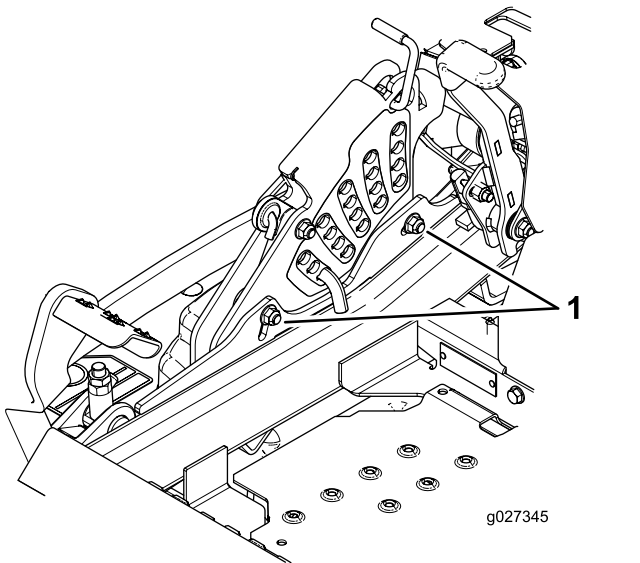
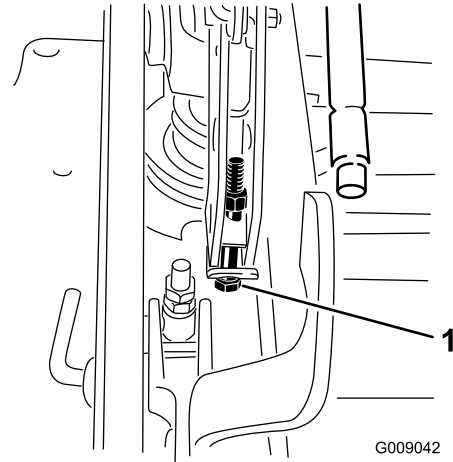

**Figure 102**

1. Bolts at the bottom of the height-of-cut plate

12. If the deck is too low, tighten the single-point-adjustment bolt by rotating it clockwise. If the deck is too high, loosen the single-point-adjustment bolt by rotating it counterclockwise (Figure 103).

**Note:** Loosen or tighten the single-point adjustment bolt enough to move the height-of-cut plate mounting bolts at least 1/3 the length of the available travel in their slots. This regains some up and down adjustment on each of the 4 deck links.



**Figure 103**

1. Single-point adjustment bolt

13. Tighten the 2 bolts at the bottom of the height-of-cut plate (Figure 102).

**Note:** In most conditions, the back blade tip should be adjusted 6.4 mm (1/4 inch) higher than the front.

14. Torque the 2 bolts to 37 to 45 N·m (27 to 33 ft-lb).  
 15. On both sides of the deck, measure from the level surface to the back tip of the blade (position B) as shown in Figure 100.

**Note:** The measurement should read 8.3 cm (3-1/4 inches)

16. Fine tune the screw adjuster by turning it to get 8.3 mm (3-1/4 inches) height (Figure 101).

To increase the height, turn the adjustment nut clockwise; to decrease, turn counterclockwise.

17. Measure until all 4 sides are the correct height.  
 18. Tighten all of the nuts on the deck-lift-arm assemblies.  
 19. Lower the discharge chute.

# Servicing the Cutting Blades

To ensure a superior quality of cut, keep the blades sharp. For convenient sharpening and replacement, you may want to keep extra blades on hand.

## Blade Safety

A worn or damaged blade can break, and a piece of the blade could be thrown toward you or bystanders, resulting in serious personal injury or death. Trying to repair a damaged blade may result in discontinued safety certification of the product.

- Inspect the blades periodically for wear or damage.
- Use care when checking the blades. Wrap the blades or wear gloves, and use caution when servicing the blades. Only replace or sharpen the blades; never straighten or weld them.
- On multi-bladed machines, take care as rotating 1 blade can cause other blades to rotate.

## Before Inspecting or Servicing the Blades

1. Park the machine on a level surface, disengage the blade-control switch (PTO), and engage the parking brake.
2. Shut off the engine, remove the key, and disconnect the spark-plug wires from the spark plugs.

## Inspecting the Blades

**Service Interval:** Before each use or daily

1. Inspect the cutting edges (Figure 104).
2. If the edges are not sharp or have nicks, remove and sharpen the blade; refer to [Sharpening the Blades](#) (page 67).
3. Inspect the blades, especially in the curved area.
4. If you notice any cracks, wear, or a slot forming in this area, immediately install a new blade (Figure 104).

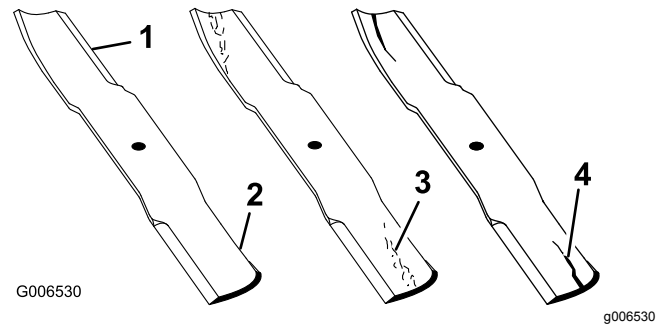

Figure 104

1. Cutting edge
2. Curved area
3. Wear/slot forming
4. Crack

## Checking for Bent Blades

1. Rotate the blades until the ends face forward and backward.
2. Measure from a level surface to the cutting edge, position A, of the blades (Figure 105).

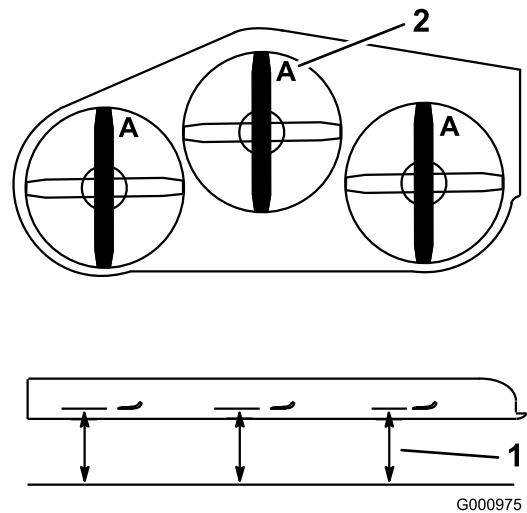

Figure 105

1. Measure here from blade to hard surface
2. Position A

3. Rotate the opposite ends of the blades forward.
4. Measure from a level surface to the cutting edge of the blades at the same position as in step 2 above.

**Note:** The difference between the dimensions obtained in steps 2 and 4 must not exceed 3 mm (1/8 inch).

**Note:** If this dimension exceeds 3 mm (1/8 inch), the blade is bent and must be replaced.

## Removing the Blades

Replace the blades if they hit a solid object, or if the blade is out of balance or bent.

1. Hold the blade end using a rag or thickly padded glove.
2. Remove the blade bolt, curved washer, and blade from the spindle shaft (Figure 106).

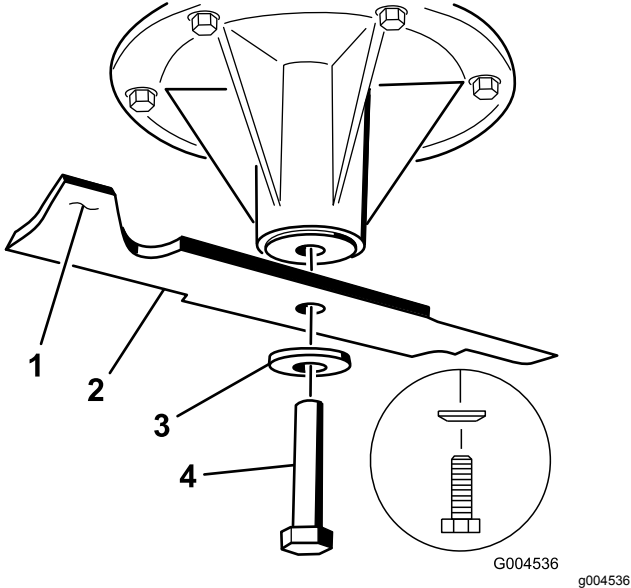

1. Sail area of the blade
2. Blade
3. Curved washer
4. Blade bolt

**Note:** If the blade is not balanced, file some metal off the end of the sail area only (Figure 107).

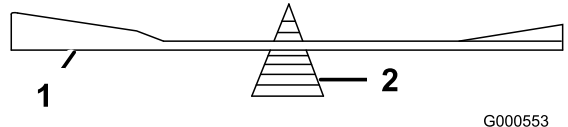

Figure 108

1. Blade
2. Balancer

3. Repeat this procedure until the blade is balanced.

## Installing the Blades

1. Install the blade onto the spindle shaft (Figure 106).

**Important:** The curved part of the blade must point upward toward the inside of the mower to ensure proper cutting.

2. Install the curved washer and blade bolt (Figure 106).

**Note:** Install the curved-washer cone toward the bolt head.

3. Torque the blade bolt to 115 to 150 N·m (85 to 110 ft-lb).

## Sharpening the Blades

1. Use a file to sharpen the cutting edge at both ends of the blade (Figure 107).

**Note:** Maintain the original angle.

**Note:** The blade retains its balance if the same amount of material is removed from both cutting edges.

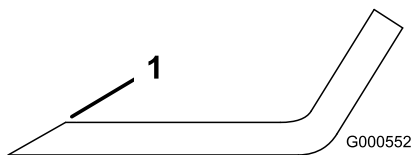

Figure 107

1. Sharpen at original angle.

2. Check the balance of the blade by putting it on a blade balancer (Figure 108).

**Note:** If the blade stays in a horizontal position, the blade is balanced and can be used.

# Removing the Mower Deck

Lock out the spring-loaded deck arms before servicing or removing the mower deck.

## ⚠ WARNING

Deck-lift arm assemblies have stored energy. Removing the deck with out releasing the stored energy can cause serious injury or death.

Do not attempt to disassemble the deck from the front frame without locking out the stored energy.

1. Park the machine on a level surface, disengage the blade-control switch (PTO), and engage the parking brake.
2. Shut off the engine, remove the key, and wait for all moving parts to stop before leaving the operating position.
3. Place the height adjustment pin in the 7.6 cm (3 inch) cutting-height location.

**Note:** This locks the deck-lift arms in the lowest position when the deck is removed and the stored energy in the deck spring is released.

4. Remove the belt covers.
5. Lift up the floor pan and insert a ratchet into the square hole in the deck idler (Figure 109).
6. Rotate the deck idler clockwise and remove the mower belt (Figure 109).

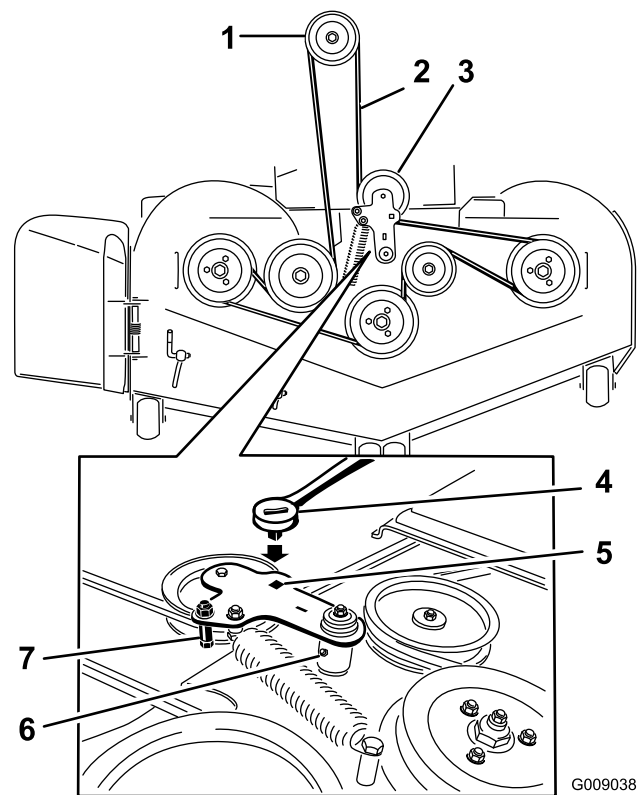

Figure 109

G009038  
g009038

- |                               |   |
|-------------------------------|---|
| 1. Clutch pulley              | 5. Square hole in the idler arm for the ratchet |
| 2. Mower belt                 | 6. Idler grease fitting                         |
| 3. Spring-loaded idler pulley | 7. Belt guide                                   |
| 4. Ratchet                    |   |
- 
7. Remove and retain the hardware on both sides of the deck as shown in Figure 110.

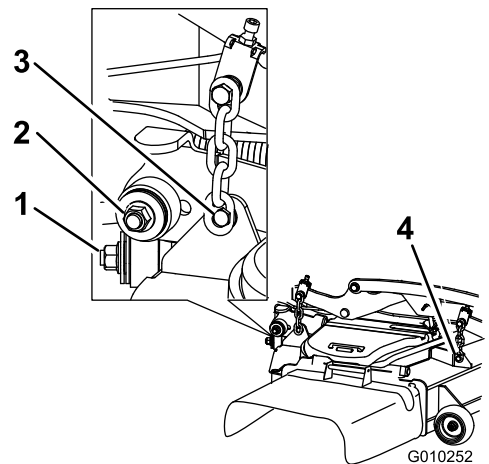

Figure 110

G010252

g010252

1. Right stabilizer
2. Deck strut (right side shown)
3. Remove the shoulder bolt and nut.
4. Remove the shoulder bolt and nut.

8. Raise the deck struts and secure them in the raised position.
9. Slide the deck out to the right side of the machine.

## Replacing the Grass Deflector

### ⚠ WARNING

An uncovered discharge opening could allow the machine to throw objects toward you or bystanders, resulting in serious injury. Also, contact with the blade could occur.

Never operate the machine unless you install a mulch plate, discharge deflector, or grass collection system.

1. Remove the locknut, bolt, spring, and spacer holding the deflector to the pivot brackets (Figure 111).
2. Remove the damaged or worn grass deflector (Figure 111).

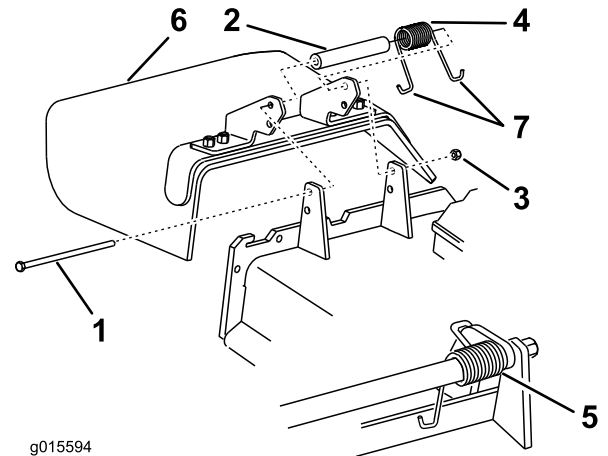

Figure 111

- |            |                         |
|------------|-------------------------|
| 1. Bolt    | 5. Spring installed     |
| 2. Spacer  | 6. Grass deflector      |
| 3. Locknut | 7. J-hook end of spring |
| 4. Spring  |                         |

3. Place the spacer and the spring onto grass deflector.
4. Place 1 J-hook end of the spring behind the deck edge.

**Note:** Make sure that 1 J-hook end of the spring is installed behind the deck edge before installing the bolt as shown in Figure 111.

5. Install the bolt and the nut.
6. Place 1 J-hook end of the spring around the grass deflector (Figure 111).

**Important:** The grass deflector must be able to rotate. Lift the deflector up to the full open position and ensure that it rotates into the full down position.

# Cleaning

## Cleaning under the Mower Deck

**Service Interval:** Before each use or daily

1. Park the machine on a level surface, disengage the blade-control switch (PTO), and engage the parking brake.
2. Shut off the engine, remove the key, and wait for all moving parts to stop before leaving the operating position.
3. Raise the mower deck to the TRANSPORT position.

## Disposing of Waste

Engine oil, batteries, hydraulic fluid, and engine coolant are pollutants to the environment. Dispose of these according to your state and local regulations.

# Storage

## Storage Safety

- Shut off the engine, remove the key, wait for all moving parts to stop, and allow the machine to cool before storing it.
- Do not store the machine or fuel near flames or drain the fuel indoors.
- Remove the key and store it in a safe place out of the reach of children.

## Cleaning and Storage

1. Disengage the blade-control switch (PTO), and engage the parking brake.
2. Shut off the engine, remove the key, and wait for all moving parts to stop before leaving the operating position.
3. Remove grass clippings, dirt, and grime from the external parts of the entire machine, especially the engine and hydraulic system. Clean dirt and chaff from the outside of the engine cylinder head fins and blower housing.

**Important:** You can wash the machine with mild detergent and water. Do not pressure wash the machine. Avoid excessive use of water, especially near the control panel, engine, hydraulic pumps, and motors.

4. Check the parking brake operation; refer to [Operating the Parking Brake \(page 20\)](#).
5. Service the air cleaner; refer to [Engine Maintenance \(page 36\)](#).
6. Grease the machine; refer to [Lubrication \(page 33\)](#).
7. Change the crankcase oil; refer to [Engine Safety \(page 36\)](#).
8. Check the tire pressure; refer to [Checking the Tire Pressure \(page 52\)](#).
9. Change the hydraulic filters; refer to [Replacing the Hydraulic Fluid and Filters \(page 63\)](#).
10. Charge the battery; refer to [Charging the Battery \(page 49\)](#).
11. Scrape any heavy buildup of grass and dirt from the underside of the mower, then wash the mower with a garden hose.

**Note:** Run the machine with the blade-control switch (PTO) engaged and the engine at high idle for 2 to 5 minutes after washing.

12. Check the condition of the blades; refer to [Servicing the Cutting Blades \(page 66\)](#).

13. Prepare the machine for storage when non-use occurs over 30 days. Prepare the machine for storage as follows:

A. Add a petroleum-based stabilizer/conditioner to fuel in the tank. Follow mixing instructions from the stabilizer manufacturer. Do not use an alcohol-based stabilizer (ethanol or methanol).

**Note:** A fuel stabilizer/conditioner is most effective when mixed with fresh fuel and used at all times.

B. Run the engine to distribute conditioned fuel through the fuel system for 5 minutes.

C. Shut off the engine, allow it to cool, and drain the fuel tank.

D. Start the engine and run it until it stops.

E. Dispose of fuel properly. Recycle the fuel according to local codes.

**Important:** Do not store fuel containing stabilizer/conditioner longer than the duration recommended by the fuel-stabilizer manufacturer.

14. Remove and check the condition of the spark plug(s); refer to [Engine Maintenance \(page 36\)](#). With the spark plug(s) removed from the engine, pour 30 ml (2 tablespoons) of engine oil into the spark plug hole. Use the starter to crank the engine and distribute the oil inside the cylinder. Install the spark plug(s). Do not install the wire on the spark plug(s).

15. Check and tighten all bolts, nuts, and screws. Repair or replace any part that is damaged.

16. Paint all scratched or bare metal surfaces. Paint is available from your Authorized Service Dealer.

17. Store the machine in a clean, dry garage or storage area. Remove the key from the switch and keep it out of reach of children or other unauthorized users. Cover the machine to protect it and keep it clean.

# Troubleshooting

| Problem  | Possible Cause  | Corrective Action   |
|--|---|---|
| The oil-temperature light is on and the engine rpm is low. | 1. The engine-control unit has limited engine rpm, known as "limp" mode.  | 1. Check the engine-oil level. If the level is above the "add" line, contact an Authorized Toro Service Dealer.   |
| The oil-pressure light is on and the engine rpm is low.    | 1. The engine-control unit has limited engine rpm, known as "limp" mode.  | 1. Let the engine cool and check the engine-oil level. If the level is above the "add" line, contact an Authorized Toro Service Dealer.   |
| The LED status light comes on.                             | <ol style="list-style-type: none"> <li>1. The engine is too hot.</li> <li>2. There is old fuel in the fuel tank.</li> <li>3. The fuel-shutoff valve is not open completely.</li> <li>4. The air cleaner is dirty.</li> <li>5. The battery is not charged.</li> <li>6. Incorrect fuel filters are being used or the fuel filters are dirty.</li> <li>7. The connections to the sensors electronic-control unit (ECU) and fuel injectors are not secured properly.</li> <li>8. There is low voltage from the battery.</li> <li>9. A fuse is blown.</li> </ol> | <ol style="list-style-type: none"> <li>1. Shut off the engine and let it cool.</li> <li>2. Use new fuel.</li> <li>3. Open the fuel-shutoff valve.</li> <li>4. Make sure that the air cleaner and precleaner are clean. Replace if necessary.</li> <li>5. Charge or replace the battery.</li> <li>6. Contact an Authorized Service Dealer.</li> <li>7. Contact an Authorized Service Dealer.</li> <li>8. Ensure that you are using a good 12 V battery and that it is fully charged.</li> <li>9. Check and replace any blown fuses.</li> </ol> |
| The starter does not crank.                                | <ol style="list-style-type: none"> <li>1. The blade-control switch is engaged.</li> <li>2. The parking brake is disengaged.</li> <li>3. The motion-control levers are not in the NEUTRAL-LOCK position.</li> <li>4. You are not sitting in the operator's seat.</li> <li>5. The battery is dead.</li> <li>6. The electrical connections are corroded or loose.</li> <li>7. A fuse is blown.</li> <li>8. A relay or switch is damaged.</li> </ol>  | <ol style="list-style-type: none"> <li>1. Disengage the blade-control switch.</li> <li>2. Engage the parking brake.</li> <li>3. Move the motion-control levers outward to the NEUTRAL-LOCK position.</li> <li>4. Sit on the operator's seat.</li> <li>5. Charge the battery.</li> <li>6. Check the electrical connections for good contact.</li> <li>7. Replace the fuse.</li> <li>8. Contact an Authorized Service Dealer.</li> </ol>  |

| Problem  | Possible Cause  | Corrective Action  |
|--|---|--|
| The engine does not start, starts hard, or fails to keep running.  | <ol style="list-style-type: none"> <li>1. The fuel tank is empty.</li> <li>2. The fuel-shutoff valve is closed.</li> <li>3. The oil level in the crankcase is low.</li> <li>4. The throttle is not in the correct position.</li> <li>5. There is dirt in the fuel filter.</li> <li>6. Dirt, water, or stale fuel is in fuel system.</li> <li>7. The air cleaner is dirty.</li> <li>8. The seat switch is not functioning properly.</li> <li>9. The electrical connections are corroded, loose, or damaged.</li> <li>10. The relay or switch is worn or damaged.</li> <li>11. The spark plug is fouled or improperly gapped.</li> <li>12. The spark-plug wire is not connected.</li> </ol> | <ol style="list-style-type: none"> <li>1. Fill the fuel tank.</li> <li>2. Open the fuel-shutoff valve.</li> <li>3. Add oil to the crankcase.</li> <li>4. Be sure that the throttle control is midway between the slow and fast positions.</li> <li>5. Replace the fuel filter.</li> <li>6. Contact an Authorized Service Dealer.</li> <li>7. Clean or replace the air-cleaner element.</li> <li>8. Check the seat-switch indicator. Replace the seat if necessary.</li> <li>9. Check the electrical connections for good contact. Clean the connector terminals thoroughly with electrical-contact cleaner, apply dielectric grease, and make the appropriate connections.</li> <li>10. Contact an Authorized Service Dealer.</li> <li>11. Adjust or replace the spark plug.</li> <li>12. Check the spark-plug wire connection.</li> </ol> |
| The engine loses power.  | <ol style="list-style-type: none"> <li>1. The engine load is excessive.</li> <li>2. The air cleaner is dirty.</li> <li>3. The oil level in the crankcase is low.</li> <li>4. The cooling fins and the air passages above the engine are plugged.</li> <li>5. The vent hole in the fuel cap is plugged.</li> <li>6. There is dirt in the fuel filter.</li> <li>7. There is dirt, water, or stale fuel in the fuel system.</li> </ol>   | <ol style="list-style-type: none"> <li>1. Reduce the ground speed.</li> <li>2. Clean the air-cleaner element.</li> <li>3. Add oil to the crankcase.</li> <li>4. Remove the obstruction from the cooling fins and the air passages.</li> <li>5. Clean or replace the fuel cap.</li> <li>6. Replace the fuel filter.</li> <li>7. Contact an Authorized Service Dealer.</li> </ol>  |
| The engine overheats.  | <ol style="list-style-type: none"> <li>1. The engine load is excessive.</li> <li>2. The oil level in the crankcase is low.</li> <li>3. The cooling fins and air passages under the engine-blower housing are plugged.</li> <li>4. The air cleaner is dirty.</li> <li>5. Dirt, water, or stale fuel is in the fuel system.</li> </ol>  | <ol style="list-style-type: none"> <li>1. Reduce the ground speed.</li> <li>2. Add oil to the crankcase.</li> <li>3. Remove the obstruction from the cooling fins and air passages.</li> <li>4. Clean or replace the air-cleaner element.</li> <li>5. Contact an Authorized Service Dealer</li> </ol>  |
| The machine pulls to the left or right (with levers fully forward) | <ol style="list-style-type: none"> <li>1. The tracking needs adjustment</li> <li>2. The tire pressure in the drive tires is not correct.</li> </ol>   | <ol style="list-style-type: none"> <li>1. Adjust the tracking.</li> <li>2. Adjust the tire pressure in the drive tires.</li> </ol>   |
| The machine does not drive.  | <ol style="list-style-type: none"> <li>1. The bypass valves are not closed tight.</li> <li>2. The pump belt is worn, loose, or broken.</li> <li>3. The pump belt is off a pulley.</li> <li>4. The idler spring is broken or missing.</li> <li>5. The hydraulic fluid level is low or too hot.</li> </ol>  | <ol style="list-style-type: none"> <li>1. Tighten the bypass valves.</li> <li>2. Change the belt.</li> <li>3. Change the belt.</li> <li>4. Replace the spring.</li> <li>5. Add hydraulic fluid to the reservoirs or let it cool down.</li> </ol>   |

| Problem                          | Possible Cause  | Corrective Action  |
|----------------------------------|---|--|
| The machine vibrates abnormally. | <ol style="list-style-type: none"> <li>1. The cutting blade(s) is/are bent or unbalanced.</li> <li>2. The blade mounting bolt is loose.</li> <li>3. The engine mounting bolts are loose.</li> <li>4. The engine pulley, idler pulley, or blade pulley is loose.</li> <li>5. The engine pulley is damaged.</li> <li>6. The blade spindle is bent.</li> <li>7. The motor mount is loose or worn.</li> </ol> | <ol style="list-style-type: none"> <li>1. Install new cutting blade(s).</li> <li>2. Tighten the blade mounting bolt.</li> <li>3. Tighten the engine mounting bolts.</li> <li>4. Tighten the appropriate pulley.</li> <li>5. Contact an Authorized Service Dealer.</li> <li>6. Contact an Authorized Service Dealer.</li> <li>7. Contact an Authorized Service Dealer.</li> </ol>   |
| The cutting height is uneven.    | <ol style="list-style-type: none"> <li>1. The blade(s) is not sharp.</li> <li>2. A cutting blade(s) is/are bent.</li> <li>3. The mower is not level.</li> <li>4. An anti-scalp roller (if applicable) is not set correctly.</li> <li>5. The underside of the mower deck is dirty.</li> <li>6. The tire pressure is incorrect.</li> <li>7. A blade spindle is bent.</li> </ol>                             | <ol style="list-style-type: none"> <li>1. Sharpen the blade(s).</li> <li>2. Install a new cutting blade(s).</li> <li>3. Level the mower from side-to-side and front-to-rear.</li> <li>4. Adjust the anti-scalp wheel height.</li> <li>5. Clean the underside of the mower deck.</li> <li>6. Adjust the tire pressure.</li> <li>7. Contact an Authorized Service Dealer.</li> </ol>   |
| The blades do not rotate.        | <ol style="list-style-type: none"> <li>1. The mower deck belt is damaged, worn, loose, or broken.</li> <li>2. The mower deck belt is off the pulley.</li> <li>3. The pump drive belt is worn, loose, or broken.</li> <li>4. The idler spring is broken or missing.</li> </ol>   | <ol style="list-style-type: none"> <li>1. Install a new deck belt.</li> <li>2. Install the mower belt on the deck pulley and check the idler pulley, idler arm, and spring for correct position and function.</li> <li>3. Check the belt tension or install a new belt.</li> <li>4. Replace the spring.</li> </ol>   |
| The clutch does not engage.      | <ol style="list-style-type: none"> <li>1. The fuse is blown.</li> <li>2. There is low voltage supply at the clutch.</li> <li>3. The coil is damaged.</li> <li>4. There is inadequate current supply.</li> <li>5. The rotor/armature air gap is too large.</li> </ol>  | <ol style="list-style-type: none"> <li>1. Replace the fuse. Check the coil resistance, battery charge, charging system, and wiring connections, and replace components if necessary.</li> <li>2. Check the coil resistance, battery charge, charging system, and wiring connections and replace parts if necessary.</li> <li>3. Replace the clutch.</li> <li>4. Repair or replace the clutch lead wire or electrical system. Clean the connector contacts.</li> <li>5. Remove the shim or replace the clutch.</li> </ol> |



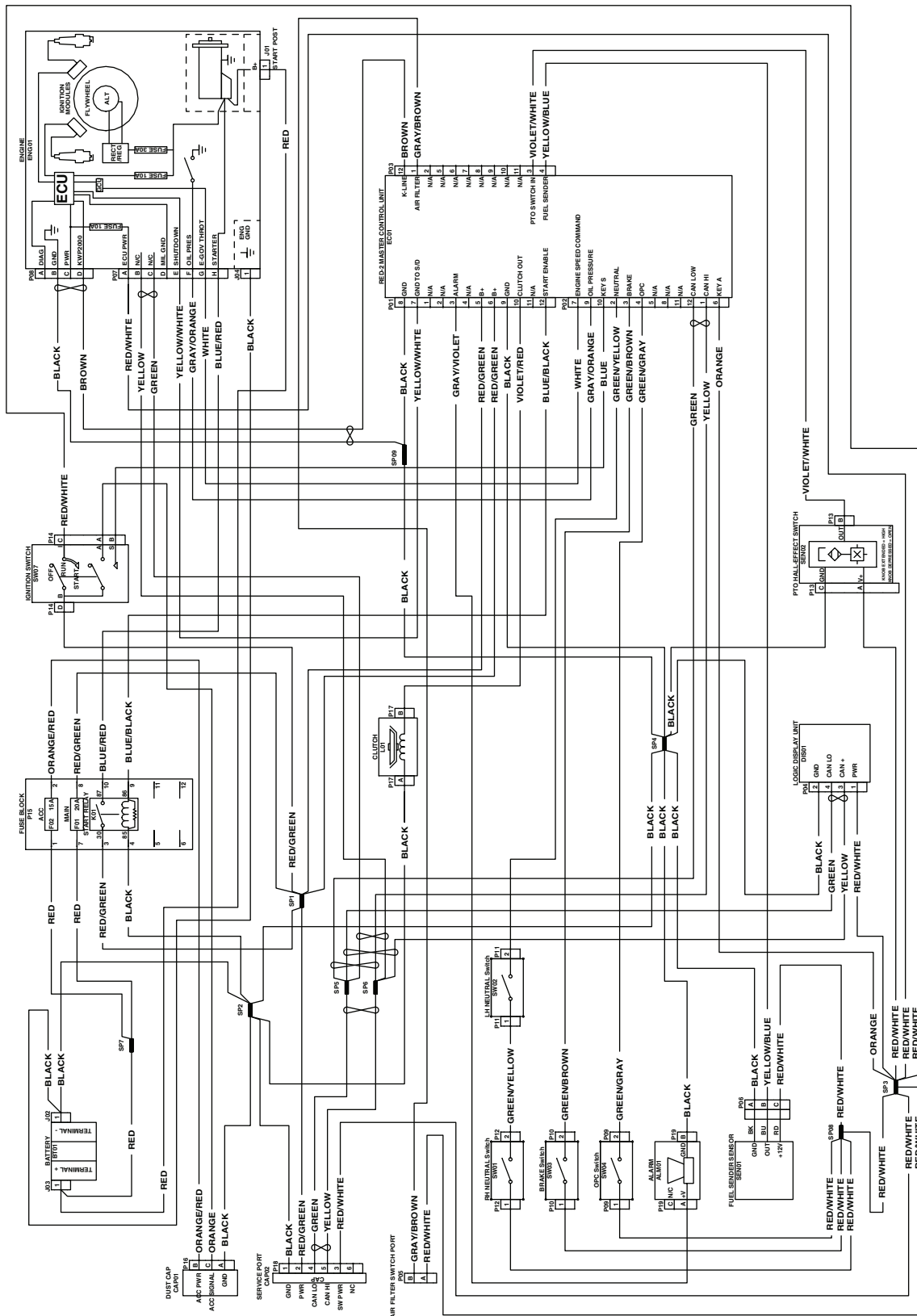

Electrical Schematic—Kohler Engines (Rev. A)

g237359