



Count on it.

Parts Catalog

**53cm Super Recycler®
Lawn Mower**

Model No. 20797—Serial No. 40000000 and Up



Ordering Replacement Parts

To order replacement parts, please supply the part number, the quantity, and the description of each part desired.

Understanding Reference Numbers

Each identified part in an illustration has a reference number. The reference number for a part also appears in the parts list, along with other information about the part.

This catalog uses two special reference number formats, one to indicate parts in a service assembly and another to indicate the quantity of a given part in an illustration.

Service Assembly Reference Numbers

Parts in service assemblies have reference numbers in the form a:b. The a represents the reference number of the entire service assembly and the b represents a sequential number unique to each part within the service assembly.

For example, a wheel assembly might be identified by reference number 6, the tire by 6:1, the valve by 6:2, and the wheel by 6:3. When you order the assembly identified by reference number 6, you receive all parts identified by reference numbers 6:1, 6:2, and 6:3. However, you may also order any part individually. Reference numbers of this type appear in illustration and in parts lists.

Reference Numbers Indicating Quantity

In an illustration, if a reference number indicates more than one part, the reference number has the form nX y. The n represents the quantity of the part, the X is the multiplication symbol, and the y represents the reference number.

For example, in an illustration, the reference number 2X 37 means that two of the parts identified by reference number 37 are indicated.

Contents

Housing Assembly	4
Rear Door and Mulch Plug Assembly	6
Bag Assembly	8
Engine and Blade Assembly	10
Front Wheel and Height-of-Cut Assembly	12
Rear Wheel and Height-of-Cut Assembly	14
Handle Assembly	16
Electrical Assembly	18
Attachments and Accessories	20

Housing Assembly

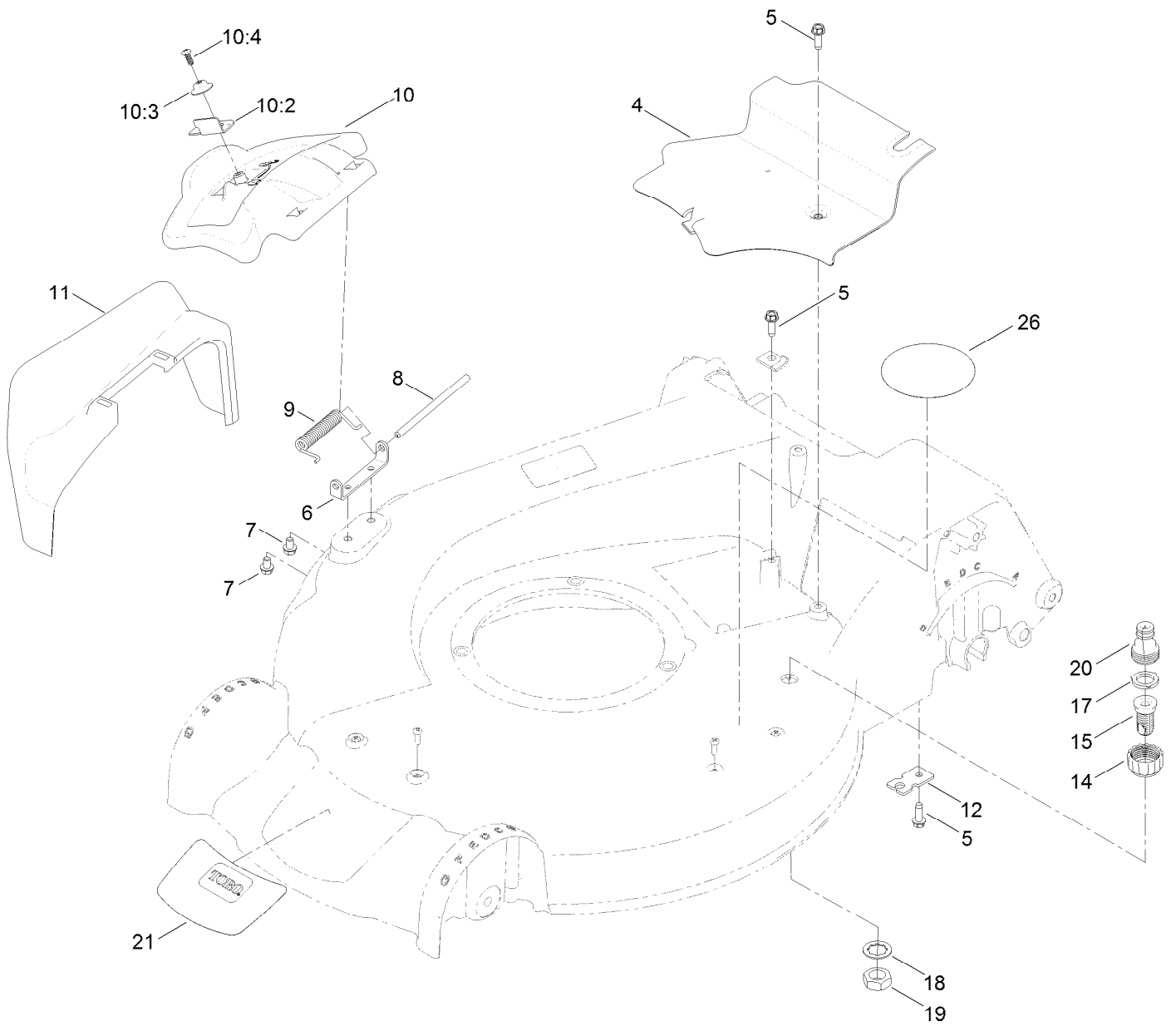

Housing Assembly (continued)

<i>Ref.</i>	<i>Part Number</i>	<i>Qty.</i>	<i>Description</i>	<i>Ref.</i>	<i>Part Number</i>	<i>Qty.</i>	<i>Description</i>
4	107-7494	1	Cover-Belt	12	107-7497	1	Bracket-Cable, Traction
5	49-2040	2	Screw-HWHTF	14	112-6401	1	Coupling-Hose, Washout Port
6	112-6416	1	Bracket-Cover	15	112-6400	1	Port-Washout
7	99-8445	2	Screw-HWH	17	112-6438	1	Washer-Seal, Washout Port
8	99-5291	1	Rod-Cover	18	3254-5	1	Washer-Tooth, Internal
9	99-5293	1	Spring-Torsion	19	3218-6	1	Nut-Jam
10	107-3717	1	Discharge Door ASM	20	112-6437	1	Adapter-Connect, Quick
10:2	107-0795	1	Latch-Door	21	136-7098	1	Decal-Deck
10:3	107-7456	1	Cap-Door	26	133-1986	1	Decal-Pos
10:4	107-7461	1	Screw-Plastite				
11	108-3753	1	Chute-Discharge, Side				

Rear Door and Mulch Plug Assembly

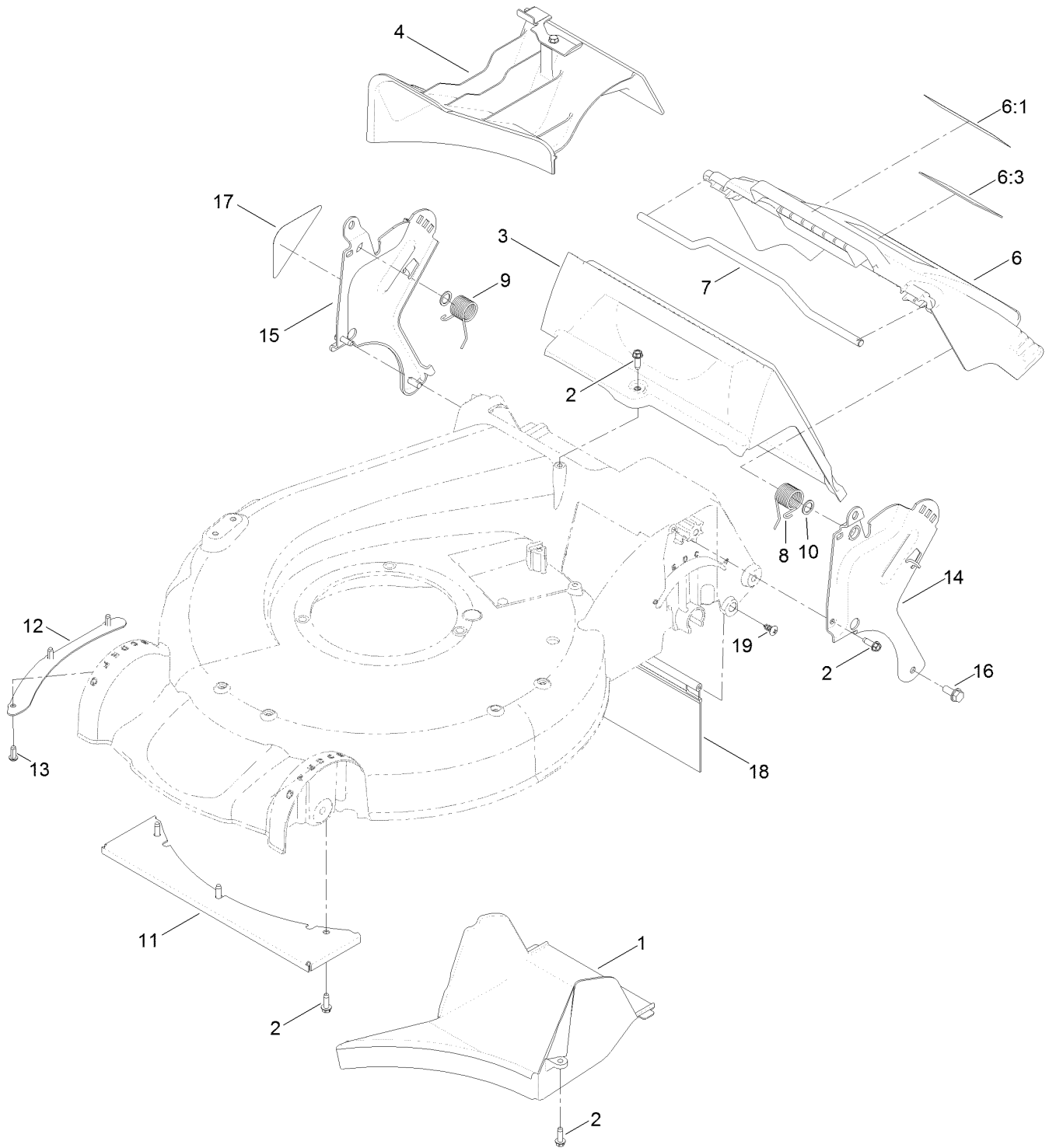

Rear Door and Mulch Plug Assembly (continued)

<i>Ref.</i>	<i>Part Number</i>	<i>Qty.</i>	<i>Description</i>	<i>Ref.</i>	<i>Part Number</i>	<i>Qty.</i>	<i>Description</i>
1	107-7495	1	Tunnel-Discharge	10	94-8196	2	Washer-Nylon
2	49-2040	8	Screw-HWHTF	11	108-3797-03	1	Plate-Cover, Front
3	114-2668	1	Chute	12	105-1316-03	1	Sheet-Lip
4	115-8413	1	Mulch Plug ASM	13	63-8590	3	Screw
6	119-3803	1	Rear Door ASM	14	114-2671-03	1	Bracket-Handle, LH
6:1	131-4514	1	Decal-Warning	15	114-2672-03	1	Bracket-Handle, RH
6:3	104-7908	1	Decal-Warning	16	32144-11	2	Screw-HWHTF
7	117-9378	1	Rod-Deflector	17	115-2884	1	Decal-Instruction
8	115-2859	1	Spring-Torsion	18	120-7011	1	Shield-Trailing
9	114-7924	1	Spring-Torsion	19	117-1092	2	Screw-PTH

Bag Assembly

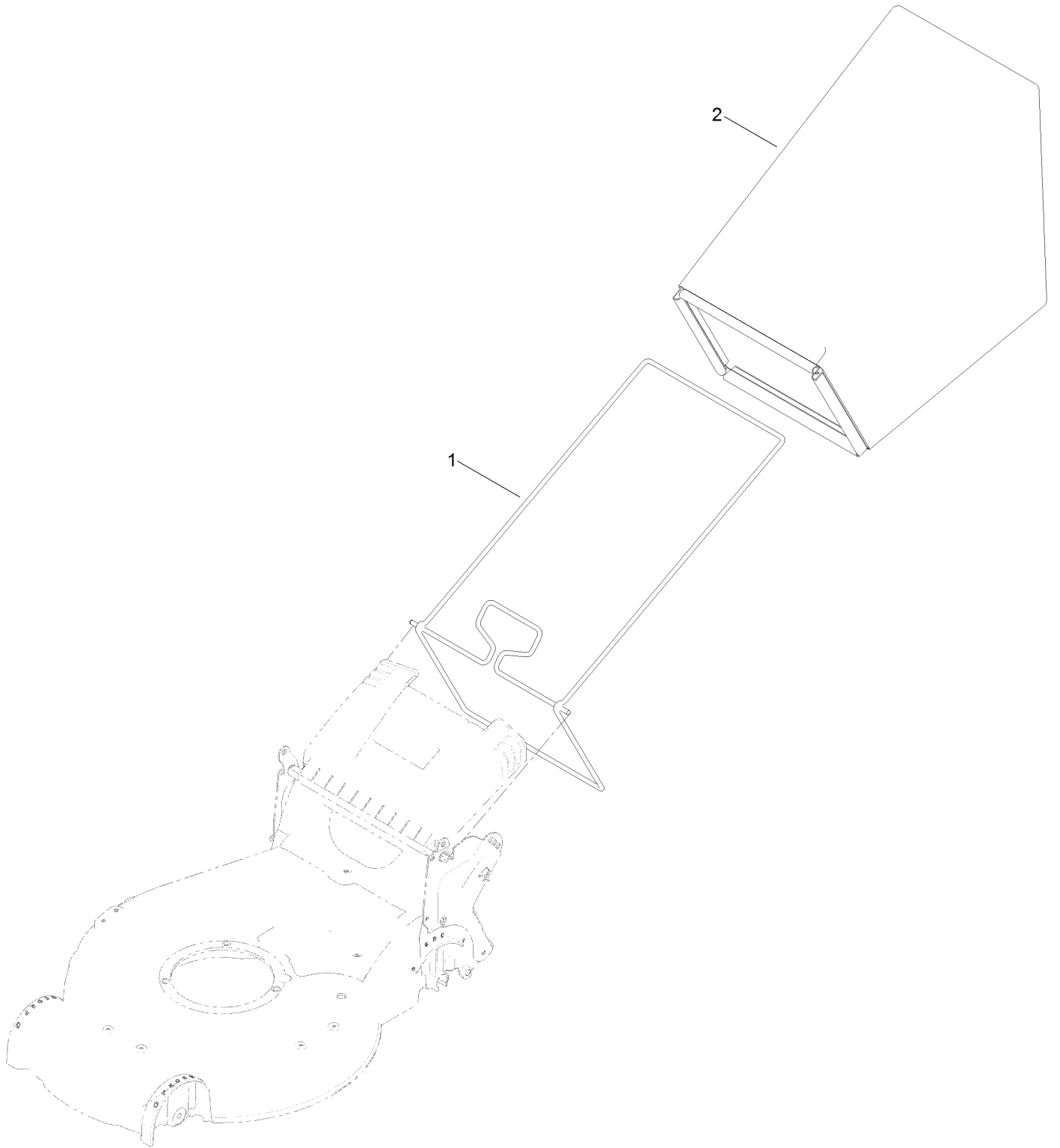

Bag Assembly (continued)

<i>Ref.</i>	<i>Part Number</i>	<i>Qty.</i>	<i>Description</i>
1	132-4529-03	1	Bag Frame ASM
2	114-2664	1	Grass Bag ASM

Engine and Blade Assembly

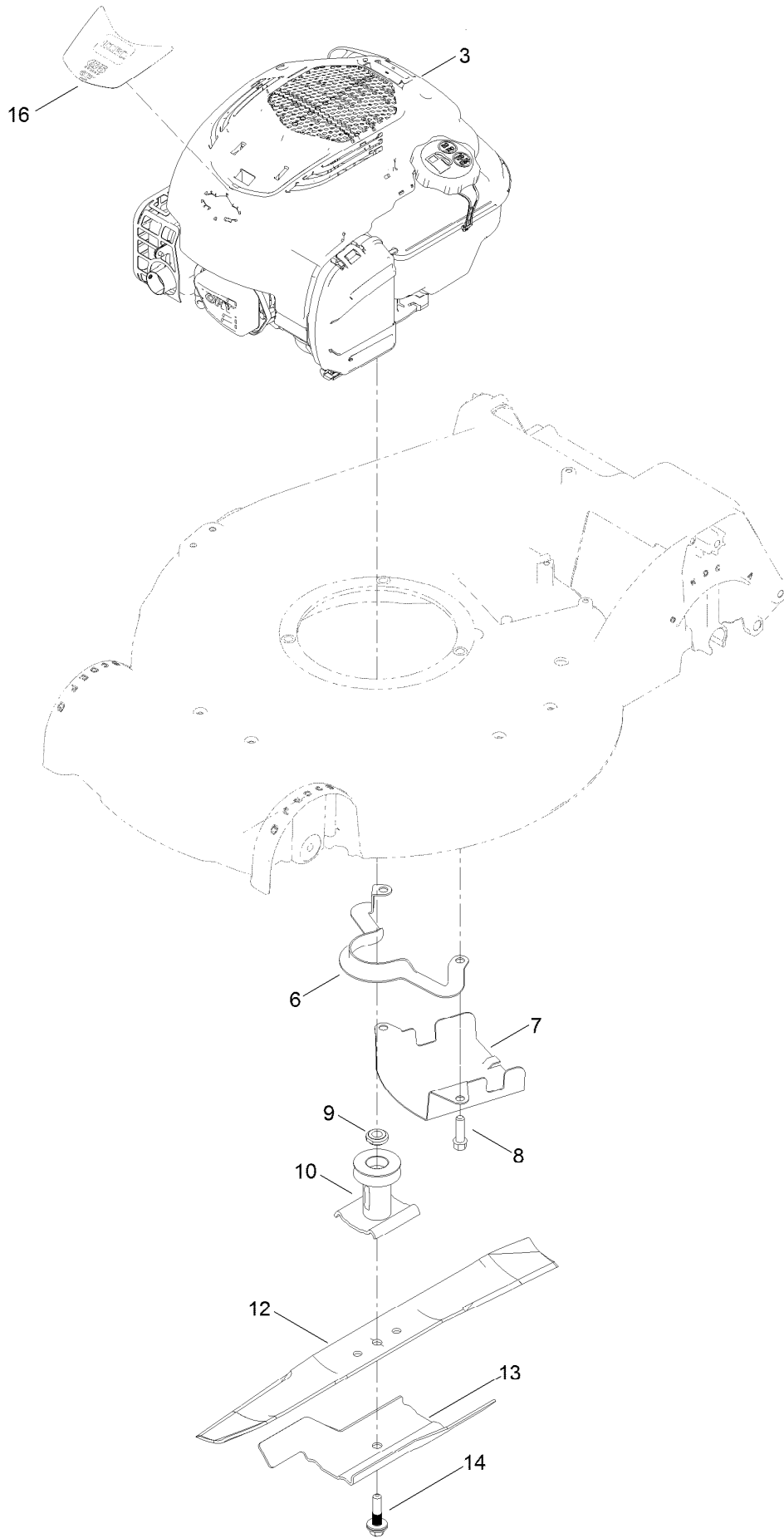

Engine and Blade Assembly (continued)

<i>Ref.</i>	<i>Part Number</i>	<i>Qty.</i>	<i>Description</i>	<i>Ref.</i>	<i>Part Number</i>	<i>Qty.</i>	<i>Description</i>
3		1	Engine-Briggs 104M050051F1 ●■	10	106-3987	1	Driver-Blade
6	108-8110-03	1	Guide-Belt	12	108-3762-03	1	Blade-Recycling
7	107-7489-03	1	Shield-Grass	13	105-6848-03	1	Accelerator-Blade
8	95-1727	3	Screw-Taptite	14	125-2466	1	Bolt-Blade
9	106-3999	1	Spacer-Driver	16	132-4472	1	Decal-Shroud

● Not serviced separately

■ Obtain parts from www.briggsandstratton.com

Front Wheel and Height-of-Cut Assembly

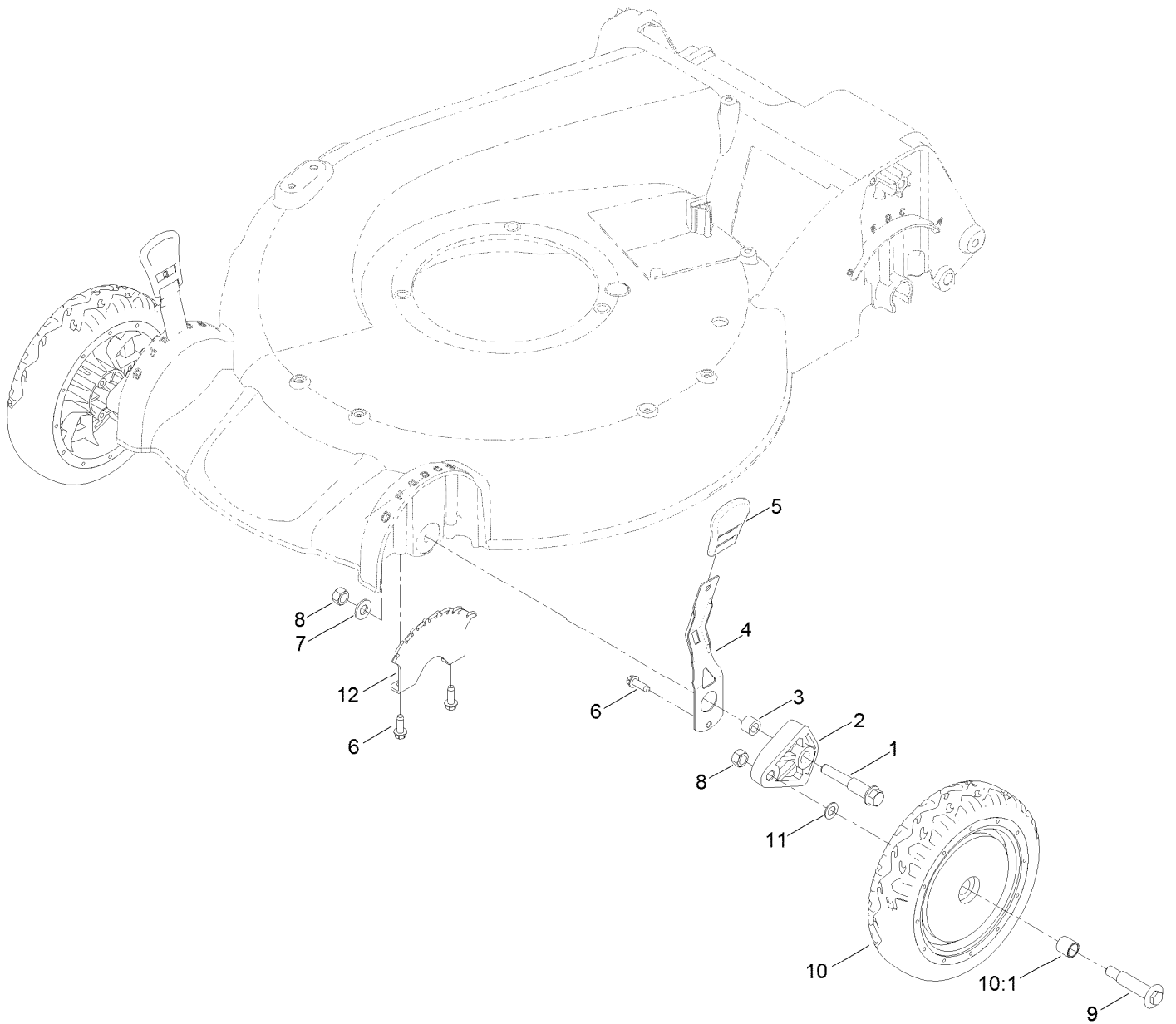

Front Wheel and Height-of-Cut Assembly (continued)

<i>Ref.</i>	<i>Part Number</i>	<i>Qty.</i>	<i>Description</i>	<i>Ref.</i>	<i>Part Number</i>	<i>Qty.</i>	<i>Description</i>
1	114-3467	2	Screw-Shoulder	8	125-5069	4	Nut-Hex
2	107-7492	2	Arm-Pivot	9	92-1057	2	Bolt-Shoulder
3	52-2480	2	Spacer-Wheel	10	107-3706	2	8 Inch Wheel ASM
4	107-7491	2	Arm-Spring	10:1	27-6250	2	Bushing
5	110-0549	2	Knob-HOC	11	40-1940	2	Washer
6	49-2040	6	Screw-HWHTF	12	107-7478	2	Plate-HOC
7	3256-24	2	Washer-Flat				

Rear Wheel and Height-of-Cut Assembly

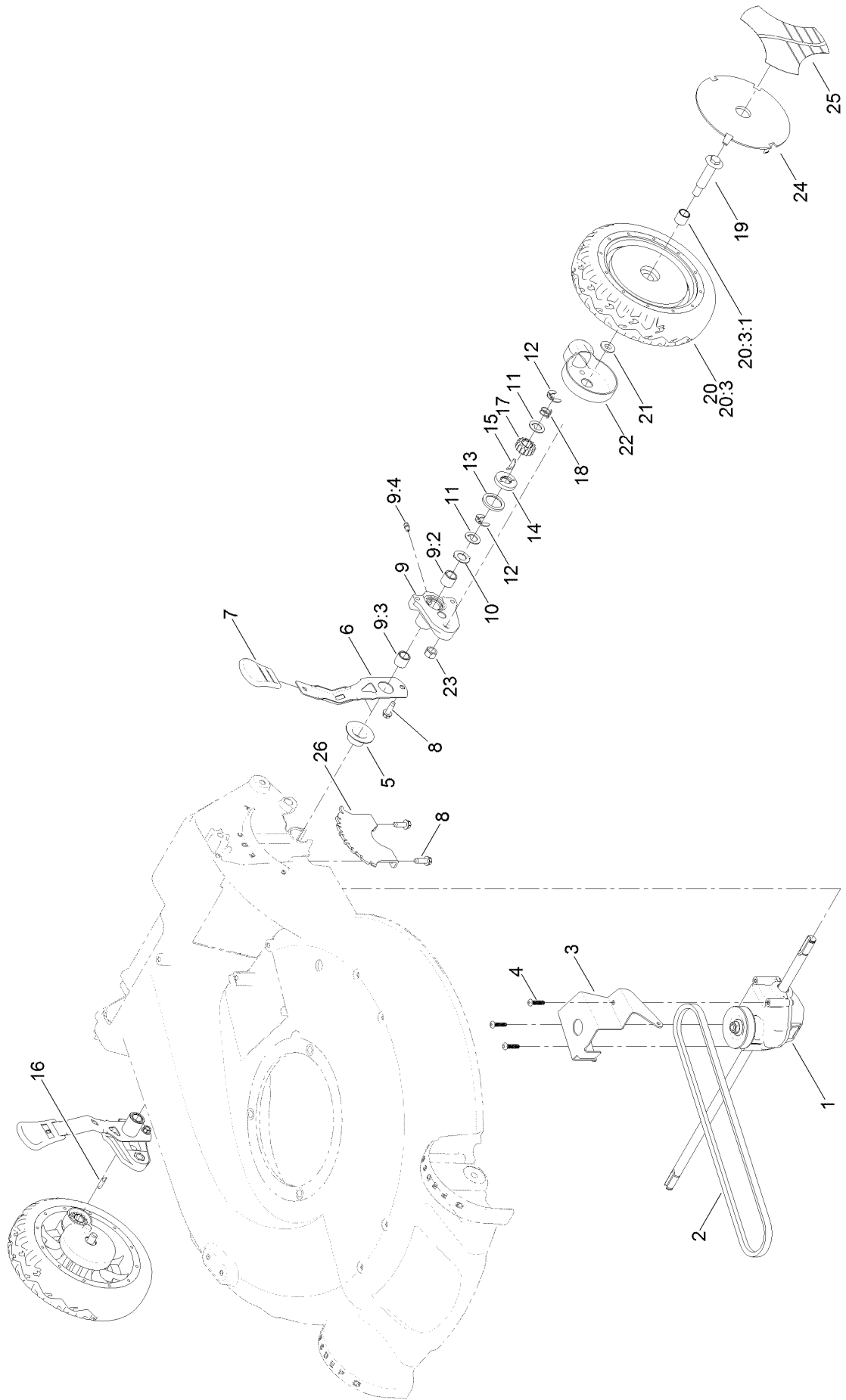

Rear Wheel and Height-of-Cut Assembly (continued)

<i>Ref.</i>	<i>Part Number</i>	<i>Qty.</i>	<i>Description</i>	<i>Ref.</i>	<i>Part Number</i>	<i>Qty.</i>	<i>Description</i>
1	121-9184	1	Transmission ASM	14	65-4760	2	Washer-Clutch
2	115-4669	1	Belt-V	15	66-6050	1	Key-Rocking, LH
3	114-7977-03	1	Bracket-Transmission	16	66-6040	1	Key-Rocking, RH
4	108-7476	3	Screw-Plastite	17	65-4750	2	Gear-Pinion
5	42-3520	2	Cap-End	18	65-4720	2	Spring-Compression
6	107-7491	2	Arm-Spring	19	92-1057	2	Bolt-Shoulder
7	110-0549	2	Knob-HOC	20	107-3707	2	8 Inch Wheel And Gear ASM
8	49-2040	6	Screw-HWHTF				
9	100-8774	2	Pivot Arm ASM	20:3		1	8 Inch Wheel ASM ●
9:2	47-2900	1	Bushing	20:3:1	27-6250	2	Bushing
9:3	70-9760	1	Bushing	21	74-1671	2	Spacer-Cover, Wheel
9:4	302-56	1	Fitting-Grease	22	74-1660	2	Cover-Wheel
10	65-4730	2	Washer-Arm, Pivot	23	125-5069	2	Nut-Hex
11	65-4740	4	Washer-Thrust, Keyed	24	100-6351	1	Cover-Wheel
12	65-2720	4	Ring-Retaining, Clip	25	100-1519	1	Label-Wheel, Smart
13	65-4710	2	Ring-Friction	26	107-7478	2	Plate-HOC

● Not serviced separately

Handle Assembly

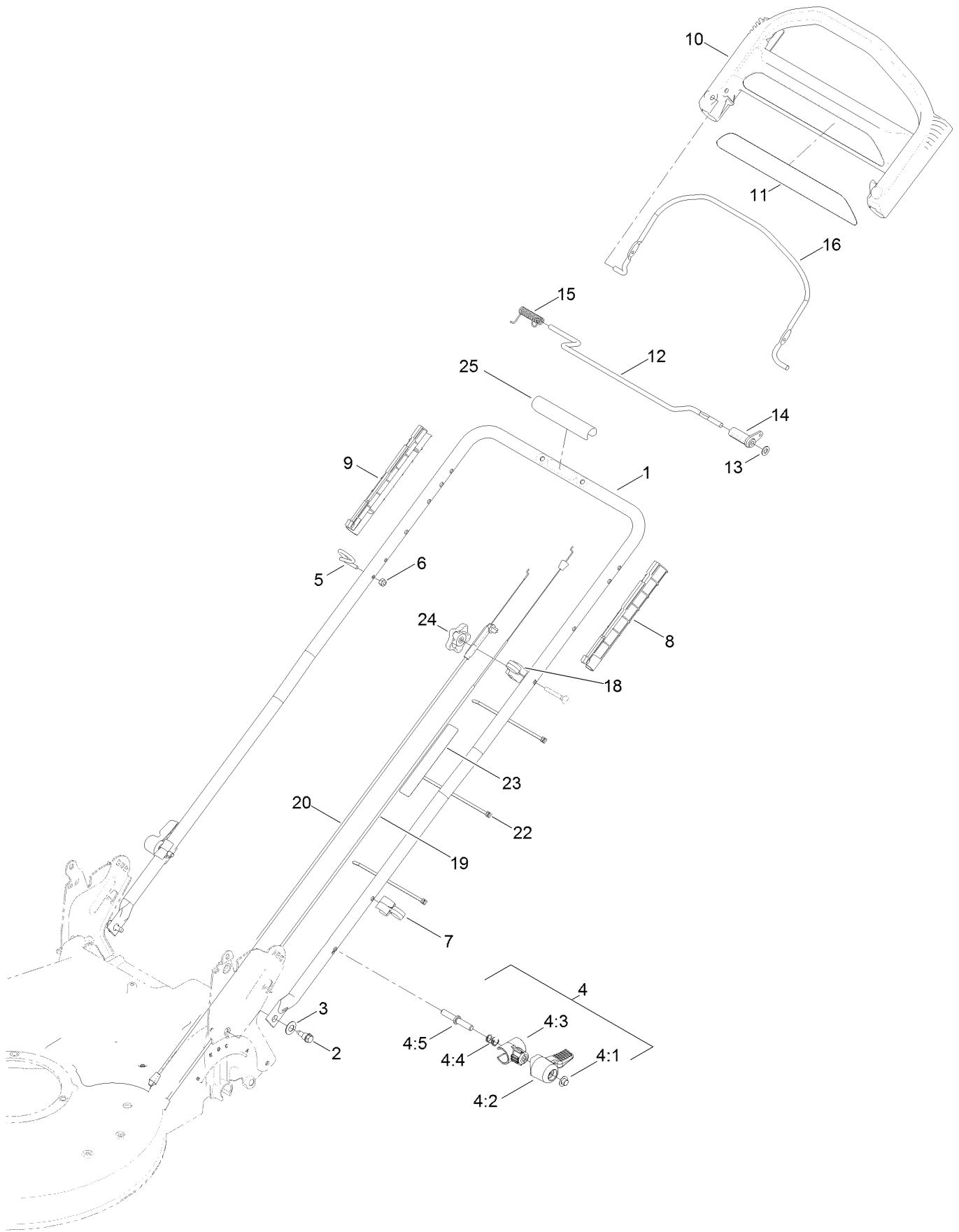

Handle Assembly (continued)

<i>Ref.</i>	<i>Part Number</i>	<i>Qty.</i>	<i>Description</i>	<i>Ref.</i>	<i>Part Number</i>	<i>Qty.</i>	<i>Description</i>
1	132-4460-05	1	Handle	10	104-8678	1	Handle-Control
2	115-1958	2	Bolt-Shoulder	11	120-3911	1	Decal-Handle
3	112-9972	2	Washer-Spring, Conical	12	99-1588	1	Bar-Control, Traction
4	115-2860	2	Quick Release ASM	13	3256-23	1	Washer-Plain
4:1	109-0917	1	Nut-Push	14	99-1589	1	Lever-Traction
4:2	114-7995	1	Lever	15	121-9118	1	Spring-Torsion
4:3	114-7996	1	Anchor-Spring	16	131-0880-03	1	Bail-Brake
4:4	115-2858	1	Spring-Compression	18	136-5864	1	Anchor-Cable
4:5	114-2675	1	Rod-Release	19	108-8158	1	Cable-Traction
5	86-9671	1	Guide-Rope	20	117-5900	1	Cable-Brake
6	3296-73	1	Nut-Lock, NI	22	614249	3	Tie-Cable
7	114-7988	1	Guide-Cable	23	132-4470	1	Decal-Traction, Adjust
8	105-6842	1	Guide-LH	24	131-0897	1	Knob-Handle, Locking
9	105-6841	1	Guide-RH	25	131-4551	1	Handle-Cover

Electrical Assembly

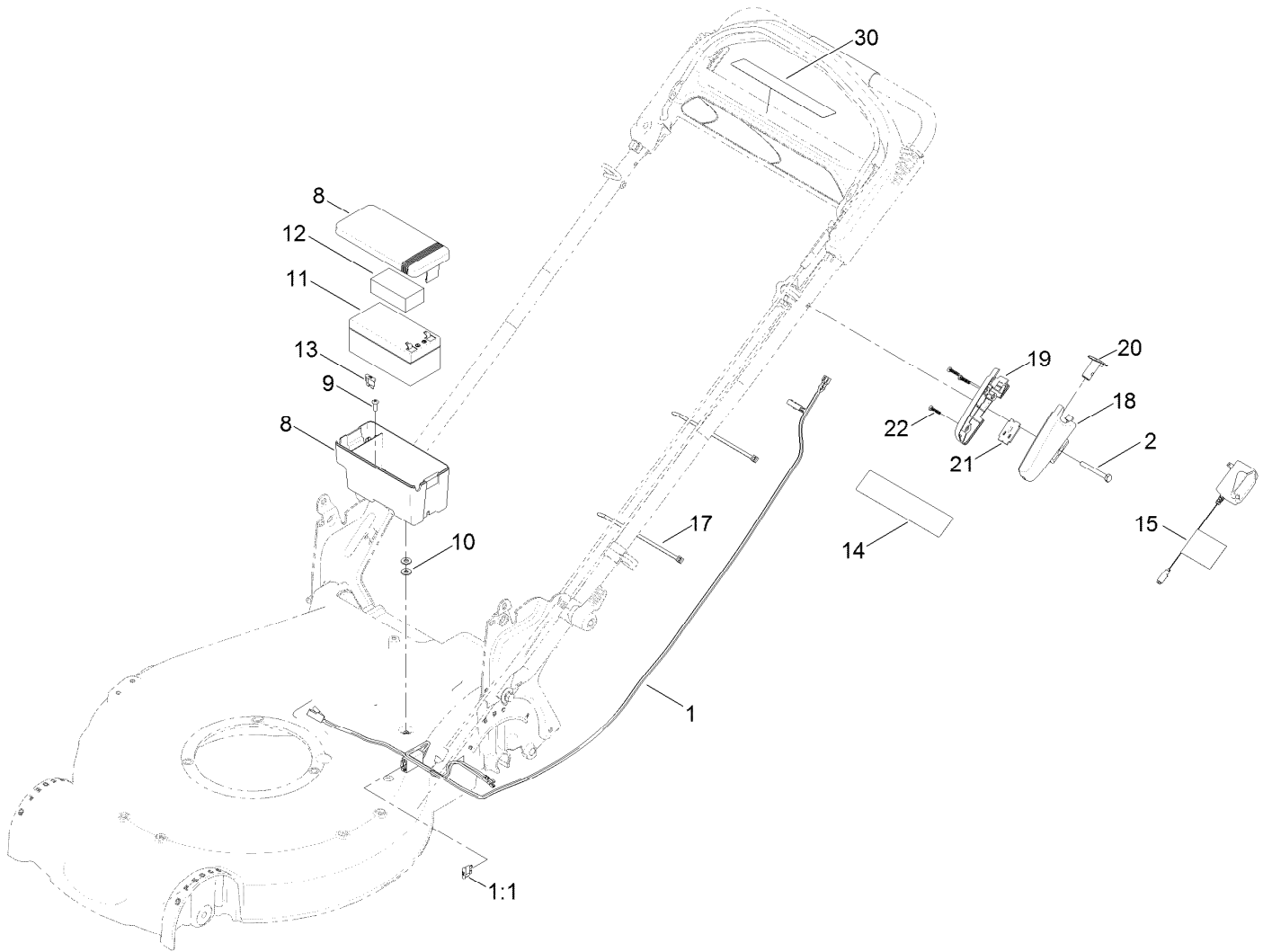

Electrical Assembly (continued)

<i>Ref.</i>	<i>Part Number</i>	<i>Qty.</i>	<i>Description</i>	<i>Ref.</i>	<i>Part Number</i>	<i>Qty.</i>	<i>Description</i>
1	125-5025	1	Harness-Wire	14	104-7953	1	Decal-Warning
1:1	99-6124	1	Fuse-40 Amp	15	120-3947	1	Charger-CE
2	321-50	1	Screw-HH	17	614249	3	Tie-Cable
8	108-4844	1	Battery Box ASM	18	133-8160	1	Housing-Switch, LH
9	32144-32	1	Screw	19	133-8161	1	Housing-Switch, RH
10	3256-22	2	Washer-Flat	20	125-2470	1	Button-Switch
11	106-8397	1	Battery-Wet	21	121-9173	1	Switch-Push Button
12	107-3774	1	Foam-Battery, Top	22	94-4496	3	Screw-PPH
13	99-6124	1	Fuse-40 Amp	30	133-1900	1	Decal-Button, Push

Attachments and Accessories

For 20797 53cm Super Recycler Lawn Mower

Product Name	Model/Part
Traction Assist Handle Kit.....	131-4590
Lawnmower Cover.....	490-7462

Notes:

Notes:

Notes:



Count on it.