



LAWN & GARDEN TRACTOR

260 Series

SET UP
INSTRUCTIONS

Loose Parts

Note: Use the chart below to identify parts for assembly.

DESCRIPTION	QTY.	USE
Bolt 1/4-20 x 3/4"	2	Attach battery cables.
Washer	2	
Locknut 1/4-20	2	
Key	1	Use in ignition switch.
Operator's Manual	1	Read manual before operating tractor.

Check Tire Pressure

Check front and rear tire pressure. See Operator's Manual for specification.

Pressure: 20 psi (138 kPa) front and rear.

Activate the Battery

Bulk electrolyte with 1.260 specific gravity must be purchased from a local battery supply outlet.

1. Remove the battery from the tractor: refer to Operator's Manual, Removing the Battery.

IMPORTANT: Be careful not to damage the long vent tube when removing the battery box.

DANGER

POTENTIAL HAZARD

- Battery electrolyte contains sulfuric acid which is a deadly poison and it causes severe burns.

WHAT CAN HAPPEN

- If you carelessly drink electrolyte you could die or if it gets onto your skin you will be burned.

HOW TO AVOID THE HAZARD

- Do not drink electrolyte and avoid contact with skin, eyes or clothing. Wear safety glasses to shield your eyes and rubber gloves to protect your hands.
- Fill the battery where clean water is always available for flushing the skin.
- Follow all instructions and comply with all safety messages on the electrolyte container.

2. Remove filler caps from the battery. Slowly pour electrolyte into each cell until the electrolyte level is up to the lower part of the tube (Fig. 1).

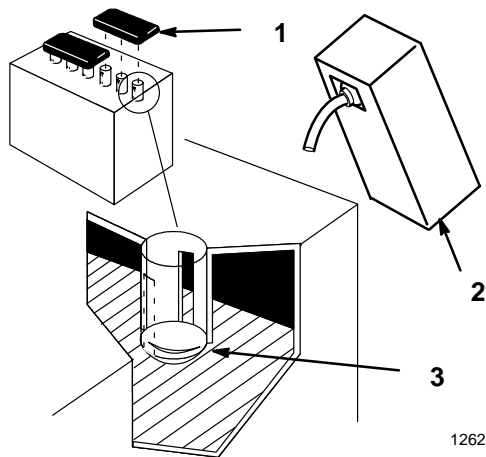

Figure 1

1. Filler caps
2. Electrolyte
3. Lower part of the tube

3. Leave the covers off and connect a 3 to 4 amp battery charger to the battery posts (Fig. 2). Charge the battery at a rate of 4 amperes or less for 4 hours (12 volts).

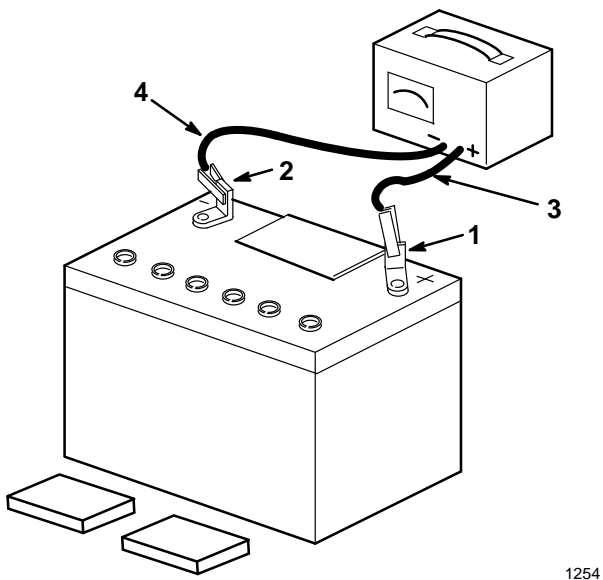

Figure 2

1. Positive post
2. Negative post
3. Charger red (+) wire
4. Charger black (-) wire

! WARNING

POTENTIAL HAZARD

- Charging battery produces gasses.

WHAT CAN HAPPEN

- Battery gasses can explode.

HOW TO AVOID THE HAZARD

- Keep cigarettes, sparks and flames away from battery.

4. When the battery is fully charged, disconnect the charger from the electrical outlet then from the negative and positive battery posts (Fig. 2).
5. Slowly pour electrolyte into each cell until the level is once again up to the "UPPER" line on the battery case (Fig. 1) and install covers.
6. Install the battery in the tractor and connect cables with (2) 1/4 x 3/4" bolts, (2) washers and (2) 1/4-20 locknuts: refer to the Operator's Manual, Installing the Battery.

Fill Crankcase with Oil

IMPORTANT: The tractor is shipped from the factory without oil in the engine crankcase

Refer to the Operator's Manual, Engine Oil Specifications for oil type, viscosity, and crankcase capacity. Only add about 80% of the specified amount of oil. Then check the oil level and add only enough oil to raise the level to the "FULL" mark on the dipstick.

Note: When checking oil, slide the dipstick fully into the filler tube, do not thread onto fill tube.

Lubricate the Tractor

Refer to the Operator's Manual, Greasing and Lubrication.

If equipped with Power Lift, check reservoir level. If necessary, fill to bottom of filler opening with Dexron Type II

Check Safety System

Refer to the Operator's Manual, Checking Safety System.

Electric Clutch Break-In

The electric clutch requires initial break-in to seat the mating surfaces. Engage/disengage the clutch 10-20 cycles with the mower installed. Rotating the blades provides load for break-in.

Adjust Electric Clutch

The electric clutch has three (3) adjustment nuts that all must be adjusted the same (Fig. 3).

1. Insert a 0.010 inch (.25 mm) feeler gauge into the slot (Fig. 3).
2. Turn the nut until light resistance is felt on the gauge.
3. Repeat for all three adjusting nuts.

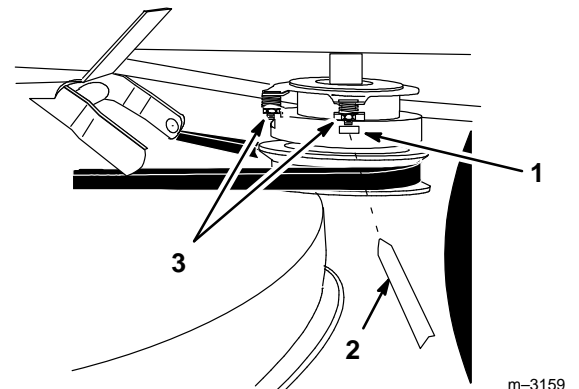

Figure 3

- | | |
|--------------------------------|------------------|
| 1. Slot | 3. Adjusting nut |
| 2. 0.010" (25 mm) Feeler gauge | |

Test Drive the Tractor

Make sure all electrical and mechanical systems are operating properly.

