



Count on it.

Operator's Manual

**TITAN® ZX 4800 or 5400
Zero-Turn-Radius Riding Mower**

Model No. 74846—Serial No. 316000001 and Up

Model No. 74848—Serial No. 316000001 and Up

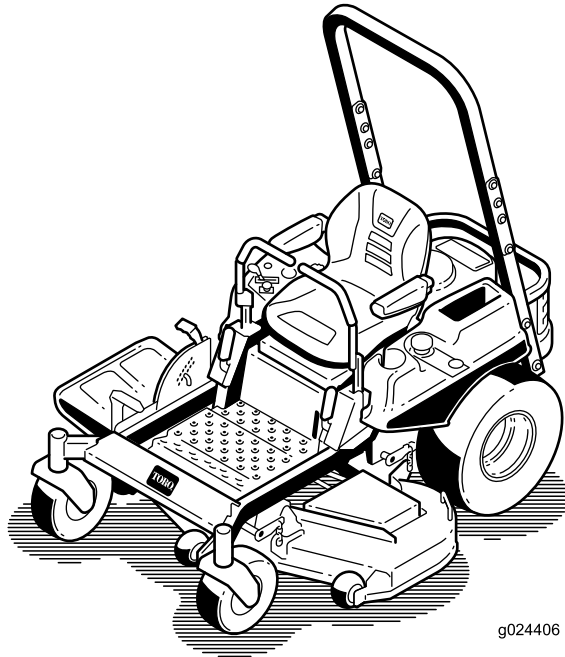

g024406



This machine is a ride-on, rotary-blade lawnmower intended to be used by homeowners in residential applications. It is primarily designed for cutting grass on well-maintained lawns. It is not designed for cutting brush, mowing grass and other growth alongside highways, or for agricultural uses.

This product complies with all relevant European directives; for details, please see the separate product specific Declaration of Conformity (DOC) sheet.

It is a violation of California Public Resource Code Section 4442 or 4443 to use or operate the engine on any forest-covered, brush-covered, or grass-covered land unless the engine is equipped with a spark arrester, as defined in Section 4442, maintained in effective working order or the engine is constructed, equipped, and maintained for the prevention of fire.

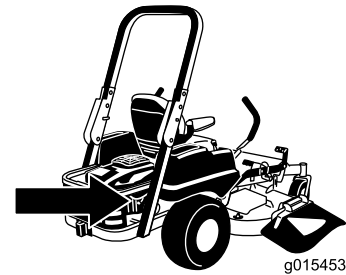

g015453

⚠ WARNING

**CALIFORNIA
Proposition 65 Warning**

The engine exhaust from this product contains chemicals known to the State of California to cause cancer, birth defects, or other reproductive harm.

Use of this product may cause exposure to chemicals known to the State of California to cause cancer, birth defects, or other reproductive harm.

Introduction

Read this information carefully to learn how to operate and maintain your product properly and to avoid injury and product damage. You are responsible for operating the product properly and safely.

You may contact Toro directly at www.Toro.com for product safety and operation training materials, accessory information, help finding a dealer, or to register your product.

Whenever you need service, genuine Toro parts, or additional information, contact an Authorized Service Dealer or Toro Customer Service and have the model and serial numbers of your product ready. [Figure 1](#) identifies the location of the model and serial numbers on the product. Write the numbers in the space provided.

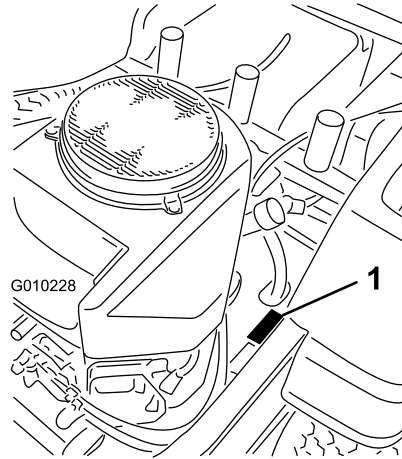

g010228

Figure 1

1. Model and serial-number location

Model No. _____

Serial No. _____

This manual identifies potential hazards and has safety messages identified by the safety alert symbol ([Figure 2](#)), which signals a hazard that may cause serious injury or death if you do not follow the recommended precautions.



g000502

Figure 2

1. Safety-alert symbol

This manual uses 2 other words to highlight information. **Important** calls attention to special mechanical information and **Note** emphasizes general information worthy of special attention.

▲ WARNING

Removing standard original equipment parts and accessories may alter the warranty, traction, and safety of the machine. Failure to use original Toro parts could cause serious injury or death. Making unauthorized changes to the engine, fuel or venting system, may violate EPA and CARB regulations.

Replace all parts including, but not limited to, tires, belts, blades, and fuel system components with original Toro parts.

For models with stated engine horsepower, the gross horsepower of the engine was laboratory rated by the engine manufacturer in accordance with SAE J1940 and rated to J2723.

Do not tamper with the engine controls or alter the governor speed; doing so may create an unsafe condition resulting in personal injury.

Contents

Safety	5	Electrical System Maintenance	41
Safe Operating Practices	5	Servicing the Battery	41
Toro Riding Mower Safety	6	Servicing the Fuses	42
Model 74846	7	Drive System Maintenance	43
Model 74848	8	Checking the Tire Pressure	43
Slope Indicator	9	Hydraulic System Maintenance	44
Safety and Instructional Decals	10	Checking the Hydraulic-Fluid Level	44
Product Overview	15	Changing the Hydraulic Filter and Fluid	44
Controls	16	Mower Deck Maintenance	46
Operation	17	Servicing the Cutting Blades	46
Adding Fuel	17	Leveling the Mower Deck	48
Think Safety First	19	Inspecting the Belts	50
Using the Rollover Protection System (ROPS)	19	Replacing the Mower Belt	50
Understanding the Safety-Interlock System	20	Removing the Mower	51
Testing the Safety-Interlock System	20	Installing the Mower Deck	52
Checking the Engine-Oil Level	20	Replacing the Grass Deflector	52
Breaking in a New Machine	20	Cleaning	53
Operating the Parking Brake	20	Washing the Underside of the Mower	53
Operating the Throttle	21	Disposing of Waste	54
Operating the Choke	21	Storage	54
Operating the Ignition Switch	21	Cleaning and Storage	54
Starting and Stopping the Engine	21	Troubleshooting	56
Operating the Blade-Control Switch (PTO)	22	Schematics	58
Driving the Machine	23		
Stopping the Machine	24		
Adjusting the Height of Cut	24		
Adjusting the Anti-Scalp Rollers	25		
Positioning the Seat	26		
Adjusting the Motion-Control Levers	26		
Pushing the Machine by Hand	26		
Converting the 48-Inch Mower to Side Discharge	27		
Converting the 54-Inch Mower to Side Discharge	29		
Using the Side Discharge	30		
Transporting the Machine	31		
Loading the Machine	31		
Operating Tips	33		
Maintenance	34		
Recommended Maintenance Schedule(s)	34		
Pre-Maintenance Procedures	35		
Service-Interval Chart	35		
Raising the Seat	35		
Releasing the Mower-Deck Curtain	35		
Lubrication	36		
Greasing the Bearings	36		
Engine Maintenance	36		
Servicing the Air Cleaner	36		
Servicing the Engine Oil	37		
Servicing the Spark Plug	39		
Cleaning the Cooling System	40		
Fuel System Maintenance	41		
Replacing the Fuel Filter	41		

Safety

The following instructions are from the EN standard EN ISO 5395:2013.

Improperly using or maintaining the machine can result in injury. To reduce the potential for injury, comply with these safety instructions and always pay attention to the safety alert symbol, which means Caution, Warning, or Danger—personal safety instruction. Failure to comply with the instruction may result in personal injury or death.

Safe Operating Practices

This product is capable of amputating hands and feet and throwing objects. Always follow all safety instructions to avoid serious injury or death.

Training

- Read the instructions carefully. Be familiar with the controls and the proper use of the equipment.
- Never allow children or people unfamiliar with these instructions to use the lawnmower. Local regulations can restrict the age of the operator.
- Never mow while people, especially children, or pets are nearby.
- Keep in mind that the operator or user is responsible for accidents or hazards occurring to other people or their property.
- Do not carry passengers.
- All drivers should seek and obtain professional and practical instruction. Such instruction should emphasize:
 - The need for care and concentration when working with ride-on machines;
 - Control of a ride-on machine sliding on a slope will not be regained by the application of the brake. The main reasons for loss of control are:
 - ◇ Insufficient wheel grip;
 - ◇ Being driven too fast;
 - ◇ Inadequate braking;
 - ◇ The type of machine is unsuitable for its task;
 - ◇ Lack of awareness of the effect of ground conditions, especially slopes;
 - ◇ Incorrect hitching and load distribution.

Preparation

- While mowing, always wear substantial, slip-resistant footwear and long trousers. Tie back any long hair. Do not wear jewelry.

- Thoroughly inspect the area where the equipment is to be used and remove all objects which may be thrown by the machine.
- Warning-Fuel is highly flammable.
 - Store fuel in containers specifically designed for this purpose.
 - Refuel outdoors only and do not smoke while refueling.
 - Add fuel before starting the engine. Never remove the cap of the fuel tank or add fuel while the engine is running or when the engine is hot.
 - If fuel is spilled, do not attempt to start the engine but move the machine away from the area of spillage and avoid creating any source of ignition until fuel vapors have dissipated.
 - Replace all fuel tanks and container caps securely.
- Replace faulty silencers.
- Before using, always visually inspect to see that the blades, blade bolts and cutter assembly are not worn or damaged. Replace worn or damaged blades and bolts in sets to preserve balance.
- On multi-bladed machines, take care as rotating one blade can cause other blades to rotate.

Operation

- Be alert, slow down and use caution when making turns. Look behind and to the side before changing directions.
- Do not operate the engine in a confined space where dangerous carbon monoxide fumes can collect.
- Mow only in daylight or in good artificial light.
- Before attempting to start the engine, disengage all blade attachment clutches and shift into neutral.
- Do not use on slopes of more than 15 degrees.
- Remember there is no such thing as a safe slope. Travel on grass slopes requires particular care. To guard against overturning:
 - do not stop or start suddenly when going up or downhill;
 - use low speeds on slopes and during tight turns;
 - stay alert for humps and hollows and other hidden hazards;
- Use care when pulling loads.
 - Use only approved drawbar hitch points.
 - Limit loads to those you can safely control.
 - Do not turn sharply. Use care when reversing.

- Watch out for traffic when crossing or near roadways.
- Stop the blades rotating before crossing surfaces other than grass.
- When using any attachments, never direct discharge of material toward bystanders nor allow anyone near the machine while in operation.
- Never operate the machine with damaged guards or without safety protective devices in place.
- Do not change the engine governor settings or overspeed the engine. Operating the engine at excessive speed can increase the hazard of personal injury.
- Before leaving the operator's position:
 - Disengage the power take-off and lower the attachments;
 - Change into neutral and set the parking brake;
 - Shut off the engine and remove the key.
- Disengage drive to attachments, shut off the engine, and disconnect the spark plug wire(s) or remove the ignition key.
 - Before clearing blockages or unclogging chute;
 - Before checking, cleaning or working on the lawnmower;
 - After striking a foreign object. Inspect the lawnmower for damage and make repairs before restarting and operating the equipment;
 - If the machine starts to vibrate abnormally (check immediately).
- Disengage drive to attachments when transporting or not in use.
- Shut off the engine and disengage drive to attachment.
 - Before filling the fuel tank;
 - Before removing the grass catcher;
 - Before making height adjustments; unless an adjustment can be made from the operator's position.
- Reduce the throttle setting during engine run-out and, if the engine is provided with a shut-off valve, turn the fuel off at the conclusion of mowing.
- Lightning can cause severe injury or death. If lightning is seen or thunder is heard in the area, do not operate the machine; seek shelter.

Maintenance and Storage

- Keep all nuts, bolts and screws tight to be sure the equipment is in safe working condition.
- Never store the equipment with fuel in the tank inside a building where fumes can reach an open flame or spark.

- Allow the engine to cool before storing in any enclosure.
- To reduce the fire hazard, keep the engine, silencer, battery compartment and fuel storage area free of grass, leaves, or excessive grease.
- Check the grass catcher frequently for wear or deterioration.
- Replace worn or damaged parts for safety.
- If the fuel tank has to be drained, this should be done outdoors.
- When machine is to be parked, stored or left unattended, lower the cutting means.

Toro Riding Mower Safety

The following list contains safety information specific to Toro products or other safety information that you must know that is not included in the CEN standard.

- Do not operate the engine in a confined space where dangerous carbon monoxide and other exhaust gasses can collect.
- Keep hands, feet, hair and loose clothing away from attachment discharge area, underside of mower and any moving parts while engine is running.
- Do not touch equipment or attachment parts which may be hot from operation. Allow to cool before attempting to maintain, adjust, or service.
- Battery acid is poisonous and can cause burns. Avoid contact with skin, eyes and clothing. Protect your face, eyes, and clothing when working with a battery.
- Battery gases can explode. Keep cigarettes, sparks, and flames away from battery.
- Use only genuine Toro replacement parts to ensure that original standards are maintained.
- Use only Toro-approved attachments.

Slope Operation

- Do not mow slopes greater than 15 degrees.
- Do not mow near drop-offs, ditches, steep banks, or water. Wheels dropping over edges can cause rollovers, which may result in serious injury, death, or drowning.
- Do not mow slopes when grass is wet. Slippery conditions reduce traction and could cause sliding and loss of control.
- Do not make sudden turns or rapid speed changes.
- Use a walk behind mower and/or a hand trimmer near drop-offs, ditches, steep banks, or water.
- Reduce speed and use extreme caution on slopes.

- Remove or mark obstacles such as rocks, tree limbs, etc. from mowing area. Tall grass can hide obstacles.
- Watch for ditches, holes, rocks dips, and rises that change the operating angle, as rough terrain could overturn the machine.
- Avoid sudden starts when mowing uphill because the mower may tip backwards.
- Be aware that loss of traction may occur going downhill. Weight transfer to the front wheels may cause drive wheels to slip and cause loss of braking and steering.
- Always avoid sudden starting or stopping on a slope. If tires lose traction, disengage the blades and proceed slowly off the slope.
- Follow the manufacturer's recommendations for wheel weights or counterweights to improve stability.
- Use extreme care with grass catchers or other attachments. These can change the stability of the machine and cause loss of control.

Using the Rollover-Protection System (ROPS)

- Keep the roll bar in the raised and locked position and use the seat belt when operating the machine.
- Be certain that the seat belt can be released quickly in the event of an emergency.
- Be aware there is no rollover protection when the roll bar is down.
- Check the area to be mowed and never fold the ROPS in areas where there are slopes, drop offs or water.
- Lower the rollbar only when absolutely necessary. Do not wear the seat belt with the roll bar folded down.
- Check carefully for overhead clearances (i.e. branches, doorways, electrical wires) before driving under any objects and do not contact them.

Model 74846

Sound Power

This unit has a guaranteed sound power level of 105 dBA, which includes an Uncertainty Value (K) of 1 dBA.

Sound power level was determined according to the procedures outlined in ISO 11094.

Sound Pressure

This unit has a sound pressure level at the operator's ear of 92 dBA, which includes an Uncertainty Value (K) of 1 dBA.

Sound power level was determined according to the procedures outlined in EN ISO 5395:2013.

Hand-Arm Vibration

Measured vibration level for left hand = 4.8 m/s²

Measured vibration level for right hand = 4.4 m/s²

Uncertainty Value (K) = 2.4 m/s²

Measured values were determined according to the procedures outlined in EN ISO 5395:2013.

Whole Body Vibration

Measured vibration level = 0.39 m/s²

Uncertainty Value (K) = 0.19 m/s²

Measured values were determined according to the procedures outlined in EN ISO 5395:2013.

Model 74848

Sound Power

This unit has a guaranteed sound power level of 105 dBA, which includes an Uncertainty Value (K) of 1 dBA.

Sound power level was determined according to the procedures outlined in ISO 11094.

Sound Pressure

This unit has a sound pressure level at the operator's ear of 92 dBA, which includes an Uncertainty Value (K) of 1 dBA.

Sound power level was determined according to the procedures outlined in EN ISO 5395:2013.

Hand-Arm Vibration

Measured vibration level for left hand = 5.8 m/s²

Measured vibration level for right hand = 3.6 m/s²

Uncertainty Value (K) = 2.3 m/s²

Measured values were determined according to the procedures outlined in EN ISO 5395:2013.

Whole Body Vibration

Measured vibration level = 0.45 m/s²

Uncertainty Value (K) = 0.22 m/s²

Measured values were determined according to the procedures outlined in EN ISO 5395:2013.

Slope Indicator

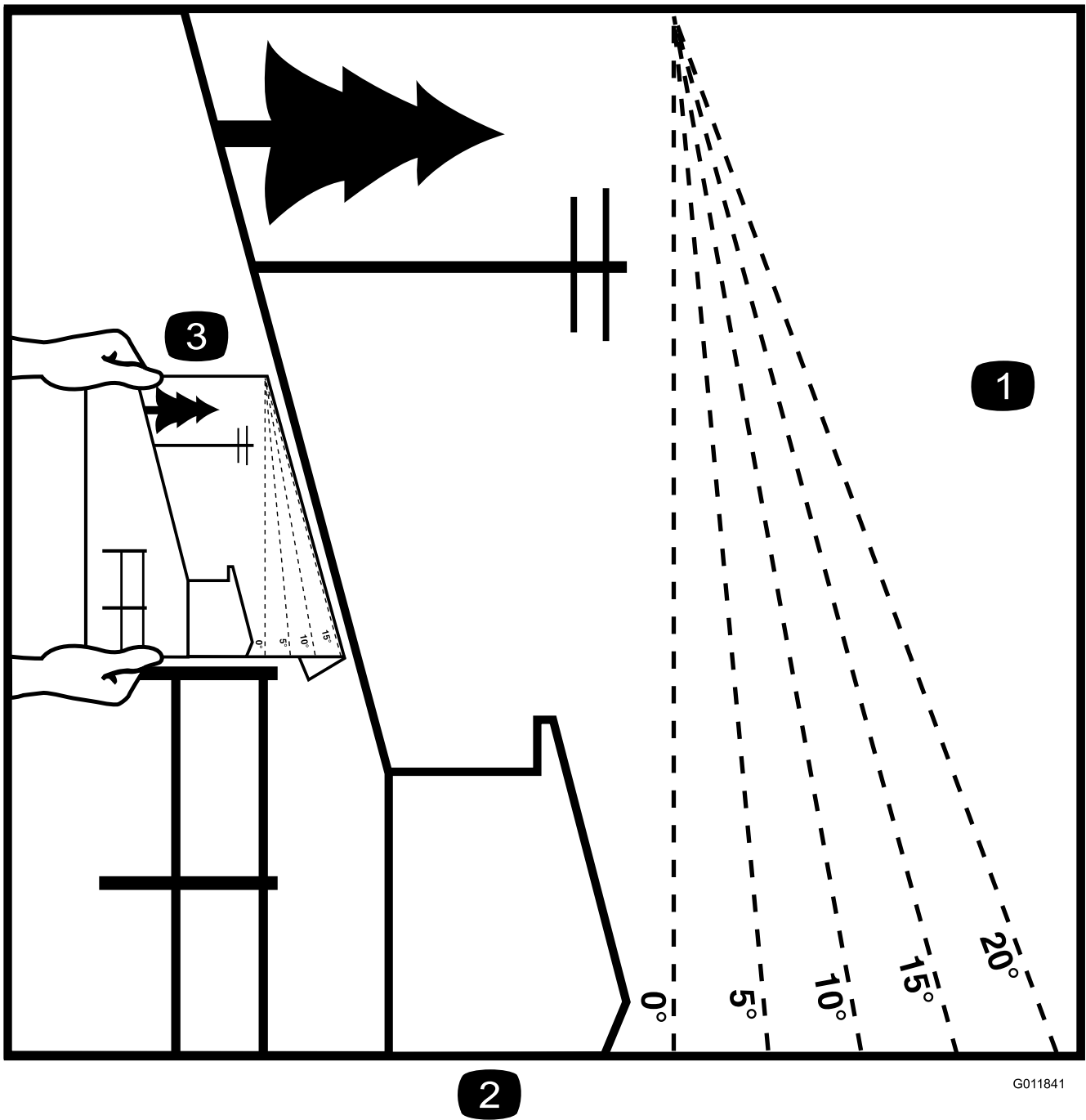

G011841

g011841

Figure 3

This page may be copied for personal use.

1. The maximum slope you can safely operate the machine on is **15 degrees**. Use the slope chart to determine the degree of slope of hills before operating. **Do not operate this machine on a slope greater than 15 degrees.** Fold along the appropriate line to match the recommended slope.
2. Align this edge with a vertical surface, a tree, building, fence pole, etc.
3. Example of how to compare slope with folded edge.

Safety and Instructional Decals



Safety decals and instructions are easily visible to the operator and are located near any area of potential danger. Replace any decal that is damaged or lost.

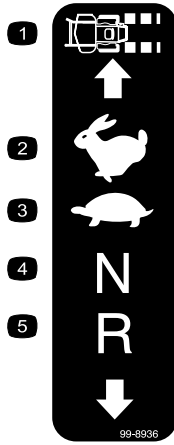

99-8936

decal99-8936

- | | |
|------------------|------------|
| 1. Machine speed | 4. NEUTRAL |
| 2. FAST | 5. REVERSE |
| 3. SLOW | |

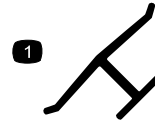

decaloemmark

Manufacturer's Mark

1. Indicates the blade is identified as a part from the original machine manufacturer.

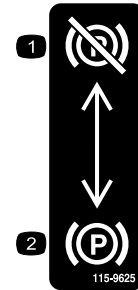

decal115-9625

115-9625

1. Parking brake—disengaged
2. Parking brake—engaged



decalbatterysymbols

Battery Symbols

Some or all of these symbols are on your battery

- | | |
|--|---|
| 1. Explosion hazard | 6. Keep bystanders a safe distance from the battery. |
| 2. No fire, open flame, or smoking. | 7. Wear eye protection; explosive gases can cause blindness and other injuries. |
| 3. Caustic liquid/chemical burn hazard | 8. Battery acid can cause blindness or severe burns. |
| 4. Wear eye protection. | 9. Flush eyes immediately with water and get medical help fast. |
| 5. Read the <i>Operator's Manual</i> . | 10. Contains lead; do not discard. |

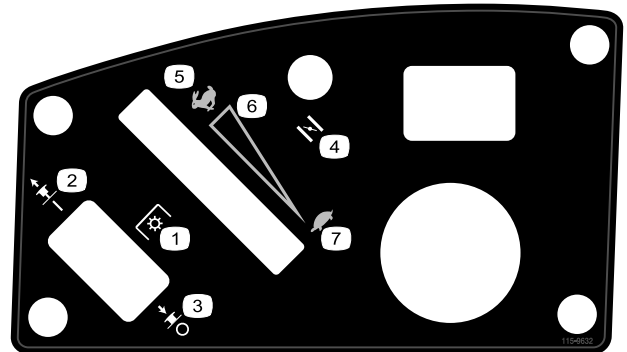

decal115-9632

115-9632

- | | |
|--|--------------------------------|
| 1. Power take-off (PTO), Blade-control switch on some models | 5. FAST |
| 2. Blade control switch—ON | 6. Continuous variable setting |
| 3. Blade control switch—OFF | 7. SLOW |
| 4. Choke | |

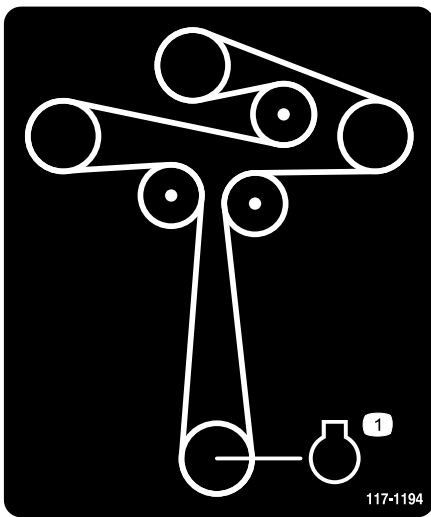

117-1194

decal117-1194

1. Engine

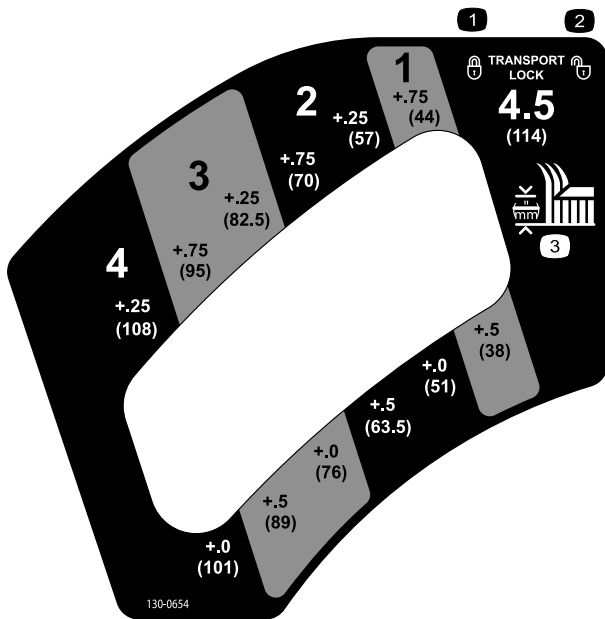

130-0654

decal130-0654

1. Transport—lock
2. Transport—unlock
3. Height of cut

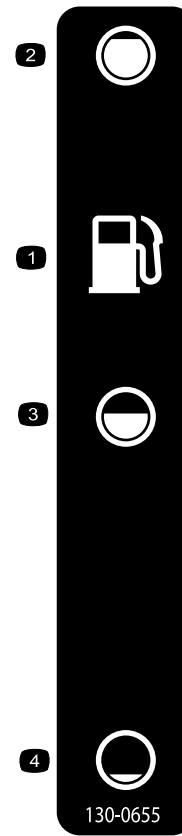

130-0655

decal130-0655

1. Fuel tank
2. Full
3. Half
4. Empty



130-0731

decal130-0731

1. Warning—thrown object hazard; keep the deflector in place.
2. Cutting hazard of hand or foot, mower blade—keep away from moving parts.

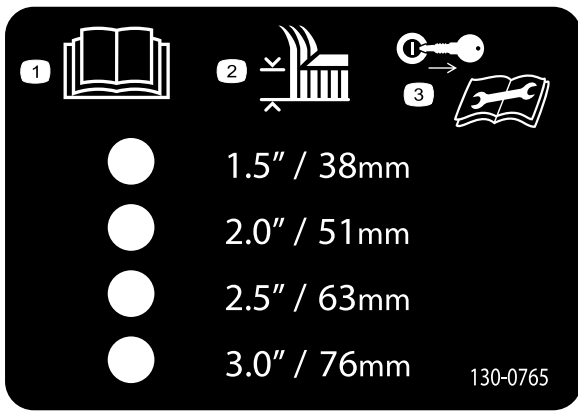

decal130-0765

130-0765

1. Read the *Operator's Manual*.
2. Height-of-cut selection
3. Remove the key from the ignition and read the *Operator's Manual* before performing maintenance.

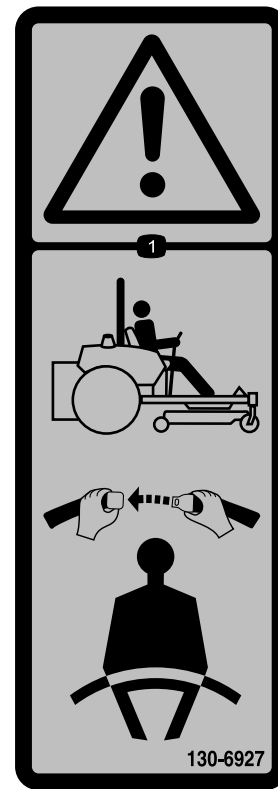

decal130-6927

130-6927

1. Warning—always use the ROPS and wear the seat belt when seated in the operator's position.

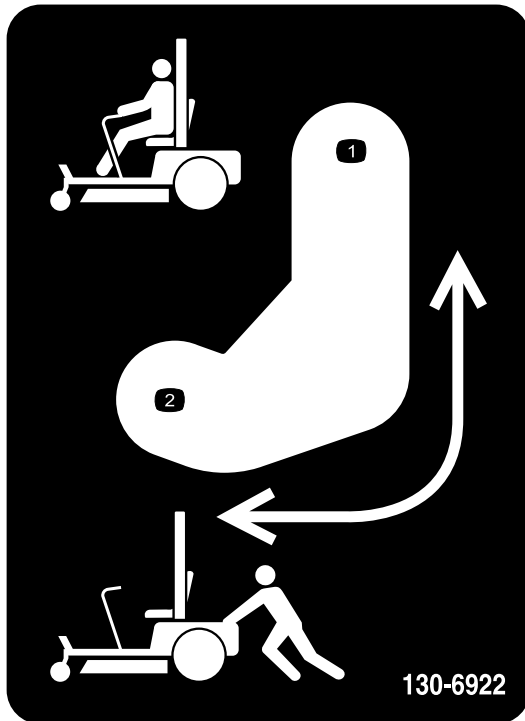

decal130-6922

130-6922

1. Bypass lever position for operating the machine.
2. Bypass lever position for pushing the machine.

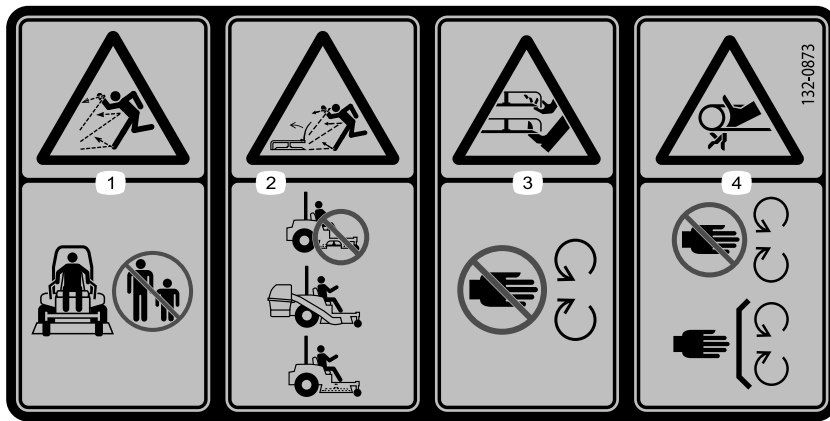

132-0873

decal132-0873

1. Thrown object hazard—keep bystanders away from the machine.
2. Thrown object hazard, mower—do not operate the without deflector, discharge cover, or grass collection system in place.
3. Cutting/dismemberment of hand or foot—stay away from moving parts.
4. Entanglement hazard, belt—keep all guards in place.

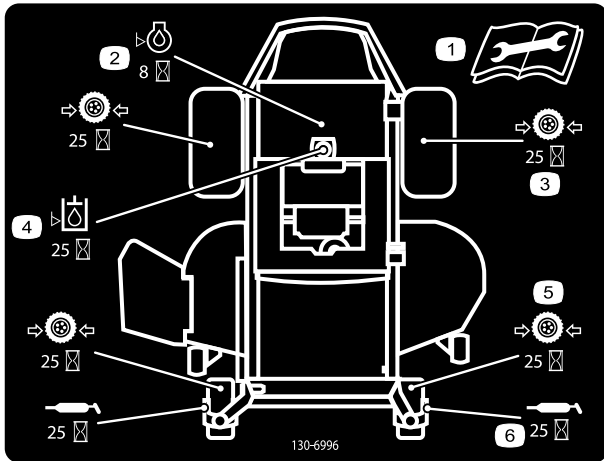

130-6996

decal130-6996

1. Read the *Operator's Manual* for information on maintenance.
2. Check the engine oil every 8 hours
3. Check the drive wheel tire pressure every 25 hours
4. Check the hydraulic oil every 25 hours
5. Check the caster wheel tire pressure every 25 hours
6. Lubricate the caster wheel every 25 hours

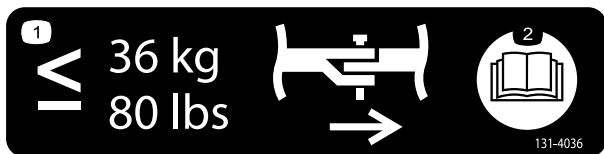

131-4036

decal131-4036

1. The maximum drawbar pull is 36 kg (80 lb).
2. Read the *Operator's Manual*.



132-0871

decal132-0871

Note: This machine complies with the industry standard stability test in the static lateral and longitudinal tests with the maximum recommended slope indicated on the decal. Review the instructions for operating the machine on slopes in the *Operator's Manual* as well as the conditions in which you would operate the machine to determine whether you can operate the machine in those conditions on that day and at that site. Changes in the terrain can result in a change in slope operation for the machine. If possible, keep the cutting units lowered to the ground while operating the machine on slopes. Raising the cutting units while operating on slopes can cause the machine to become unstable.

1. Warning—read the *Operator's Manual*; do not operate this machine unless you are trained; wear hearing protection.
2. Cutting, dismembering, and entanglement hazard—keep hands away from moving parts; keep all guards and shields in place.
3. Thrown object hazard—keep bystanders away.
4. Ramp hazard—when loading onto a trailer, do not use dual ramps; only use a singular ramp wide enough for the machine and that has an incline less than 15° ; back up the ramp (in reverse) and drive forward off the ramp.
5. Bodily harm hazard—do not carry passengers; look behind you when mowing in reverse.
6. Tipping hazard on slopes—do not use on slopes near open water; do not use on slopes greater than 15° .

Product Overview

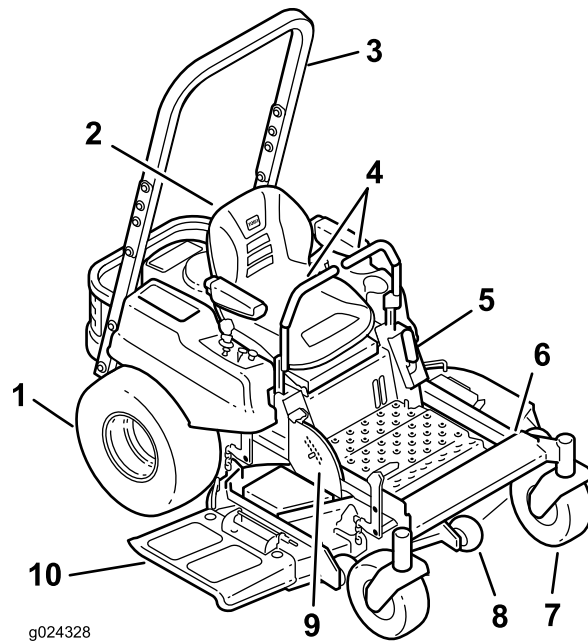

g024328

g024328

Figure 4

- | | | | |
|--------------------------------------|--------------------------|---|---------------|
| 1. Drive wheel | 4. Motion-control levers | 7. Front caster wheel | 10. Deflector |
| 2. Operator seat | 5. Parking brake | 8. Anti-scalp roller | |
| 3. Rollover Protection System (ROPS) | 6. Footrest | 9. Foot pedal deck lift and height of cut | |

Controls

Become familiar with all the controls before you start the engine and operate the machine (Figure 5).

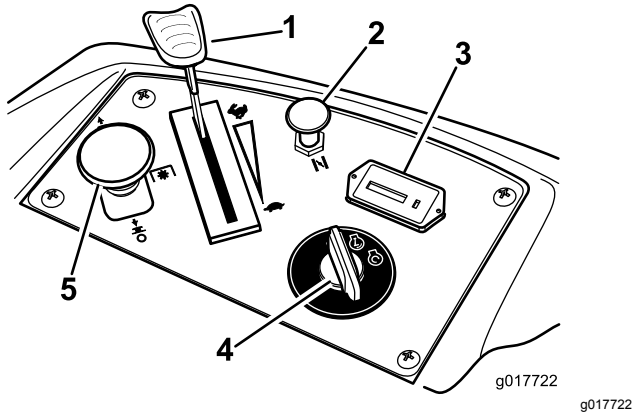

Figure 5

- | | |
|---------------------|-------------------------------|
| 1. Throttle control | 4. Ignition switch |
| 2. Choke | 5. Blade-control switch (PTO) |
| 3. Hour meter | |

Ignition Switch

The ignition switch has 3 positions: START, RUN, and OFF.. The key will turn to the START position and move back to the RUN position upon release. Turning the key to the OFF position will shut off the engine; however, always remove the key when leaving the machine to prevent the engine from accidentally starting (Figure 5).

Throttle Control

The throttle control is variable between the FAST and SLOW position. Moving throttle lever forward increases engine speed and moving throttle lever to the rear decreases engine speed. Moving the throttle forward into the detent is full throttle (Figure 5).

Choke

Use the choke to start a cold engine. Pull the choke knob up to engage it. Push down on the choke knob to disengage it.

Blade Control Switch (Power Takeoff)

The blade-control switch engages and disengages power to the mower blades (Figure 5).

Hour Meter

The hour meter records the number of hours the blades operate. It operates when the blade-control

switch (PTO) is engaged. Use these times for scheduling regular maintenance (Figure 5).

Fuel Gauge

The fuel window located below the operator position can be used to verify the level of gasoline in the tank (Figure 6).

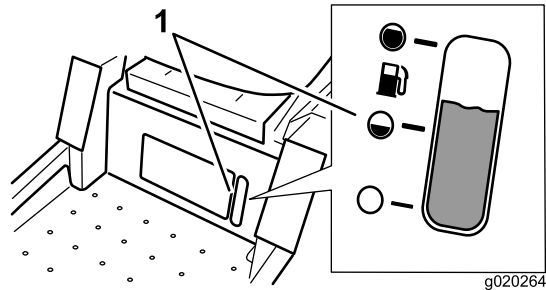

Figure 6

1. Fuel-gauge window

Motion-Control Levers

The motion-control levers are speed-sensitive controls of independent-wheel motors. Moving a lever forward or backward turns the wheel on the same side forward or in reverse; wheel speed is proportional to the amount the lever is moved. Move the control levers outward from the center to the NEUTRAL-LOCK position and exit the machine (Figure 4). Always position the motion-control levers into the NEUTRAL-LOCK position when you stop the machine or leave it unattended.

Parking-Brake Lever

The parking-brake lever is located on left side of the console (Figure 4). The brake lever engages a parking brake on the drive wheels. Pull the lever up and rearward to engage the brake. Push the lever forward and down to disengage the brake.

Foot Pedal Deck-Lift System

The foot pedal deck-lift system allows the operator to lower and raise the deck from the seated position. The operator can use the foot pedal to lift the deck briefly to avoid obstacles or lock the deck in the highest height of cut or transport position (Figure 4).

Height-of-Cut Lever

The height-of-cut lever works with the foot pedal to lock the deck in a specific cutting height. Only adjust the height of cut while machine is not moving (Figure 4).

Attachments/Accessories

A selection of Toro approved attachments and accessories is available for use with the machine to enhance and expand its capabilities. Contact your Authorized Service Dealer or Distributor or go to www.Toro.com for a list of all approved attachments and accessories.

Operation

Note: Determine the left and right sides of the machine from the normal operating position.

Adding Fuel

- For best results, use only clean, fresh, unleaded gasoline with an octane rating of 87 or higher ((R+M)/2 rating method).
- Oxygenated fuel with up to 10% ethanol or 15% MTBE by volume is acceptable.
- **Do not** use ethanol blends of gasoline (such as E15 or E85) with more than 10% ethanol by volume. Performance problems and/or engine damage may result which may not be covered under warranty.
- **Do not** use gasoline containing methanol.
- **Do not** store fuel either in the fuel tank or fuel containers over the winter unless a fuel stabilizer is used.
- **Do not** add oil to gasoline.

⚠ DANGER

In certain conditions during fueling, static electricity can be released causing a spark which can ignite the gasoline vapors. A fire or explosion from gasoline can burn you and others and can damage property.

- **Always place gasoline containers on the ground away from your vehicle before filling.**
- **Do not fill gasoline containers inside a vehicle or on a truck or trailer bed because interior carpets or plastic truck bed liners may insulate the container and slow the loss of any static charge.**
- **When practical, remove gas-powered equipment from the truck or trailer and refuel the equipment with its wheels on the ground.**
- **If this is not possible, then refuel such equipment on a truck or trailer from a portable container, rather than from a gasoline dispenser nozzle.**
- **If a gasoline dispenser nozzle must be used, keep the nozzle in contact with the rim of the fuel tank or container opening at all times until fueling is complete.**

⚠ WARNING

Gasoline is harmful or fatal if swallowed. Long-term exposure to vapors can cause serious injury and illness.

- Avoid prolonged breathing of vapors.
- Keep face away from nozzle and gas tank or conditioner opening.
- Keep gas away from eyes and skin.

⚠ DANGER

In certain conditions, gasoline is extremely flammable and highly explosive. A fire or explosion from gasoline can burn you and others and can damage property.

- Fill the fuel tank outdoors, in an open area, when the engine is cold. Wipe up any gasoline that spills.
- Never fill the fuel tank inside an enclosed trailer.
- Do not fill the fuel tank completely full. Add gasoline to the fuel tank until the level is 6 to 13 mm (1/4 to 1/2 inch) below the bottom of the filler neck. This empty space in the tank allows gasoline to expand.
- Never smoke when handling gasoline, and stay away from an open flame or where gasoline fumes may be ignited by a spark.
- Store gasoline in an approved container and keep it out of the reach of children. Never buy more than a 30-day supply of gasoline.
- Do not operate without entire exhaust system in place and in proper working condition.

Using Stabilizer/Conditioner

Use a fuel stabilizer/conditioner in the machine to provide the following benefits:

- Keeps gasoline fresh during storage of 90 days or less. For longer storage it is recommended that the fuel tank be drained.
- Cleans the engine while it runs
- Eliminates gum-like varnish buildup in the fuel system, which causes hard starting

Important: Do not use fuel additives containing methanol or ethanol.

Add the correct amount of gas stabilizer/conditioner to the gas.

Note: A fuel stabilizer/conditioner is most effective when mixed with fresh gasoline. To minimize the chance of varnish deposits in the fuel system, use fuel stabilizer at all times.

Filling the Fuel Tank

Shut off the engine and move the motion controls to the PARK position.

Important: Do not overfill fuel tank. Fill the fuel tank to the bottom of the filler neck. The empty space in the tank allows the fuel to expand. Overfilling may result in fuel leakage or damage to the engine or emission system.

1. Clean around the fuel-tank cap and remove the cap.
2. **Slowly** add regular, unleaded gasoline until the fuel reaches the base of the filler neck [Figure 7](#).

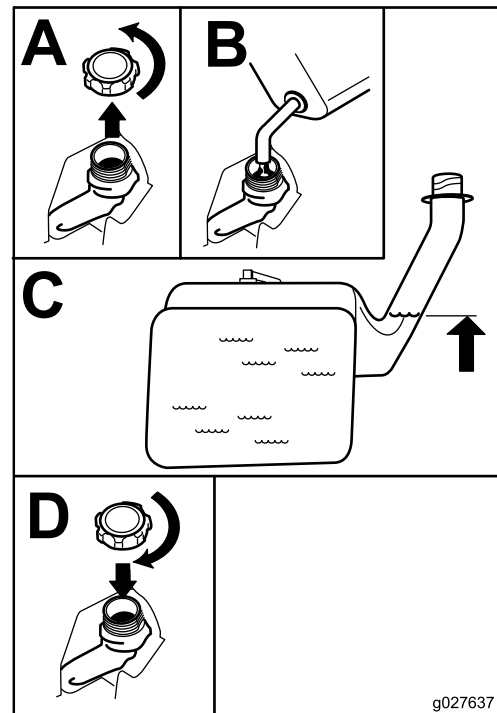

Figure 7

g027637

3. Install the fuel-tank cap securely and tighten until it clicks.

Note: Wipe up any gasoline that may have spilled.

Think Safety First

Please read all safety instructions and symbols in the safety section. Knowing this information could help you or bystanders avoid injury.

⚠ DANGER

Operating the machine on wet grass or steep slopes can cause sliding and loss of control.

- Do not operate on slopes greater than 15 degrees.
- Reduce speed and use extreme caution on slopes.
- Do not operate the machine near water.

⚠ DANGER

Wheels dropping over edges can cause rollovers, which may result in serious injury, death, or drowning.

Do not operate the machine near drop-offs.

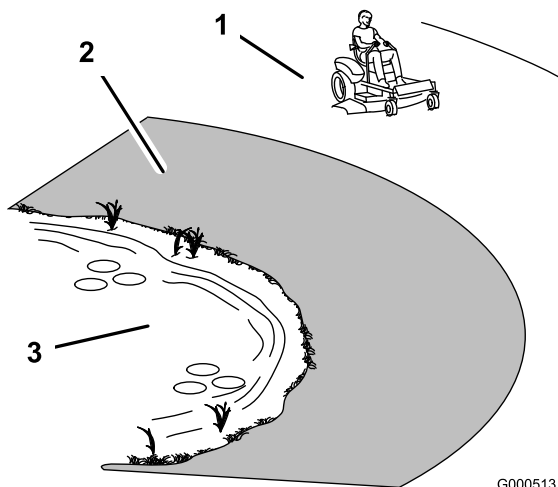

Figure 8

1. Safe zone—use the machine here.
2. Use a walk-behind mower and/or hand trimmer near drop-offs and water.
3. Water

⚠ CAUTION

This machine produces sound levels in excess of 85 dBA at the operator's ear and can cause hearing loss through extended periods of exposure.

Wear hearing protection when operating this machine.

The use of protective equipment for eyes, ears, hands, feet, and head is recommended.

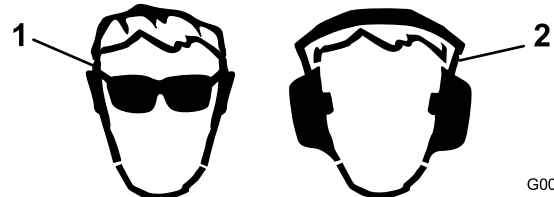

Figure 9

1. Wear eye protection.
2. Wear hearing protection.

Using the Rollover Protection System (ROPS)

⚠ WARNING

To avoid injury or death from rollover: keep the roll bar installed and use the seat belt.

⚠ WARNING

There is no rollover protection when the roll bar is removed.

- Drive slowly and carefully.
- Check carefully for overhead clearances (i.e. branches, doorways, electrical wires) before driving under any objects and do not contact them.

Understanding the Safety-Interlock System

⚠ WARNING

If the safety-interlock switches are disconnected or damaged, the machine could operate unexpectedly, causing personal injury.

- Do not tamper with the interlock switches.
- Check the operation of the interlock switches daily and replace any damaged switches before operating the machine.

The safety-interlock system is designed to prevent the engine from starting unless:

- The blades are disengaged.
- The motion-control levers are in the PARK position.

The safety-interlock system also is designed to shut off the engine whenever the control levers are out of the PARK position and you rise from the seat.

Testing the Safety-Interlock System

Test the safety-interlock system before you use the machine each time. If the safety system does not operate as described below, have an Authorized Service Dealer repair the safety system immediately.

1. While sitting on the seat, with the control levers in the PARK position, and move the blade-control switch to the ON position. Try starting the engine; the engine should not crank.
2. While sitting on the seat, move the blade-control switch to the OFF position. Move either motion control lever to the center, unlocked position. Try starting the engine; the engine should not crank. Repeat with the other motion-control lever.
3. While sitting on the seat, move the blade control switch to the OFF position, and lock the motion-control levers in the PARK position. Start the engine. While the engine is running, engage the blade-control switch, and rise slightly from the seat; the engine should stop.
4. While sitting on the seat, move the blade-control switch to the OFF position, and lock the motion-control levers in the PARK position. Start the engine. While the engine is running, move the motion-control levers to the center, unlocked position, engage the blade-control switch, and rise slightly from the seat; the engine should stop.

Checking the Engine-Oil Level

Before you start the engine and use the machine, check the oil level in the engine crankcase; refer to [Checking the Engine-Oil Level \(page 37\)](#).

Breaking in a New Machine

New engines take time to develop full power. Mower decks and drive systems have higher friction when new, placing additional load on the engine. Allow 40 to 50 hours of break-in time for new machines to develop full power and best performance.

Operating the Parking Brake

Always set the parking brake when you stop the machine or leave it unattended.

Setting the Parking Brake

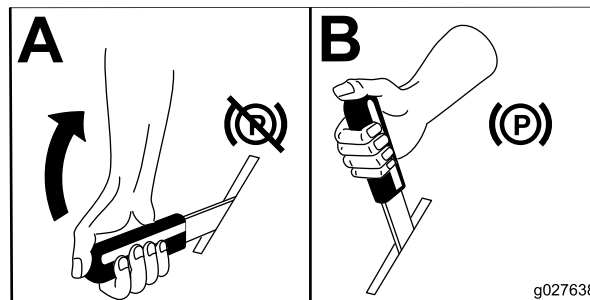

Figure 10

Releasing the Parking Brake

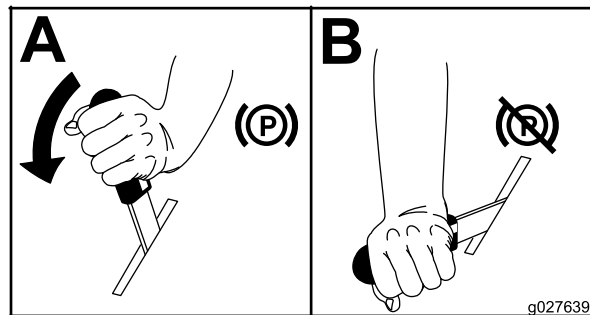

Figure 11

Operating the Throttle

The throttle control can be moved between the SLOW and FAST positions (Figure 12).

Always use the FAST position when turning on the mower deck with the blade-control switch (PTO).

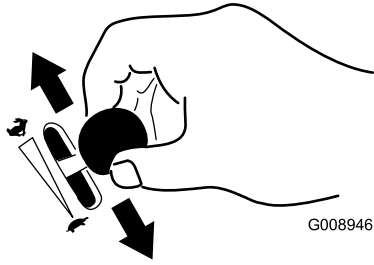

Figure 12

g008946

Operating the Choke

Use the choke to start a cold engine.

1. If the engine is cold, use the choke to start the engine.
2. Pull up on the choke knob to engage the choke before using the ignition switch (Figure 13).
3. Push down on the choke to disengage the choke after the engine starts (Figure 13).

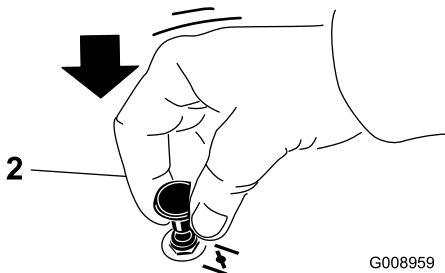
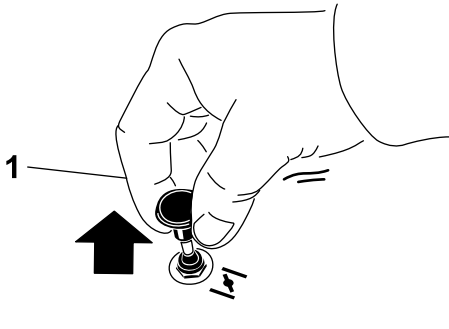

Figure 13

g008959

1. ON position

2. OFF position

Operating the Ignition Switch

1. Turn the ignition key to the START position (Figure 14).

Note: When the engine starts, release the key.

Note: Additional starting cycles may be required when starting the engine for the first time after the fuel system has been without fuel completely.

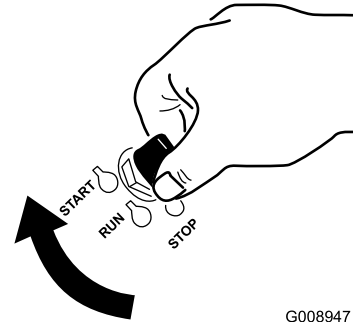

Figure 14

G008947

g008947

2. Turn the ignition key to the STOP position.

Starting and Stopping the Engine

Starting the Engine

Start the engine as shown in Figure 15.

Note: A warm or hot engine may not require choking.

Important: Do not engage starter for more than 5 seconds at a time. If the engine fails to start allow a 15 second cool-down period between attempts. Failure to follow these instructions can burn out the starter motor.

Note: If the fuel system was depleted of fuel—add fuel to the machine and use additional starting cycles when starting the engine.

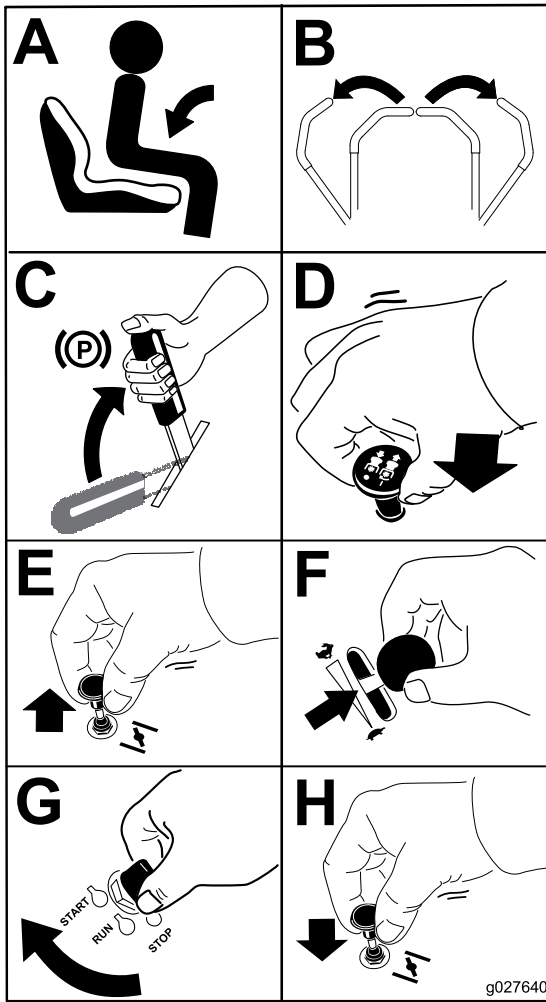

Figure 15

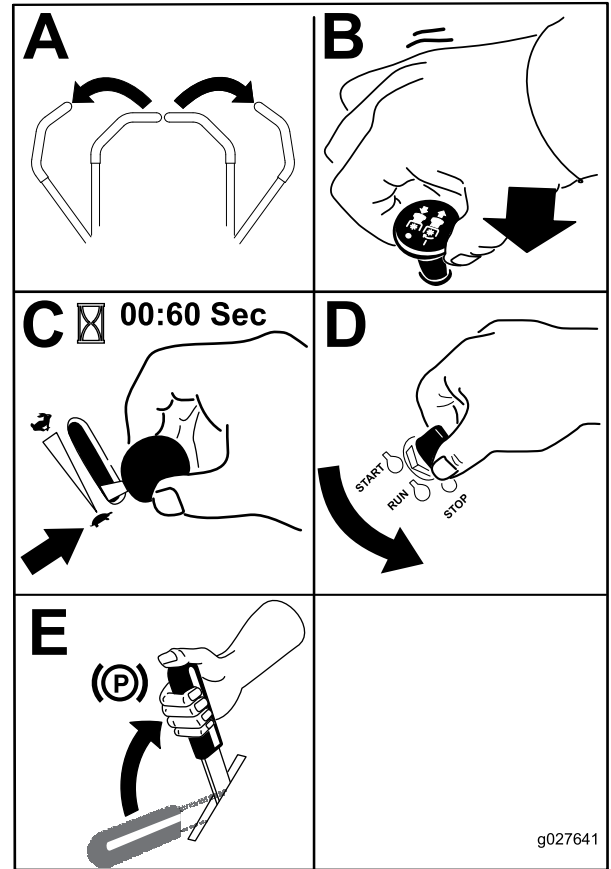

Figure 16

Stopping the Engine

⚠ CAUTION

Injury can occur if children or bystanders move or attempt to operate the machine while it is unattended.

Always remove the ignition key and set the parking brake when leaving the machine unattended, even if just for a few minutes.

Operating the Blade-Control Switch (PTO)

The blade-control switch (PTO) starts and stops the mower blades and any powered attachments.

Engaging the Blade-Control Switch (PTO)

Engage the blade-control switch (PTO) with the throttle position at FAST.

Note: Engaging the blade-control switch (PTO) with the throttle position at half or less will cause excessive wear to the drive belts.

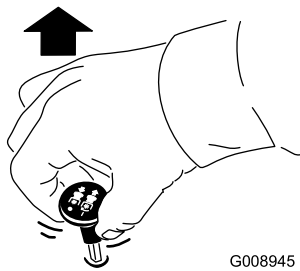

G008945

g008945

Figure 17

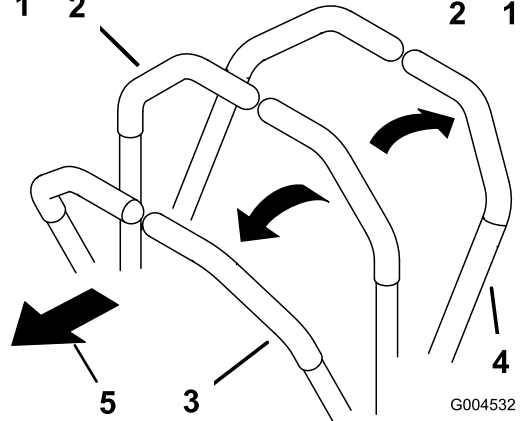
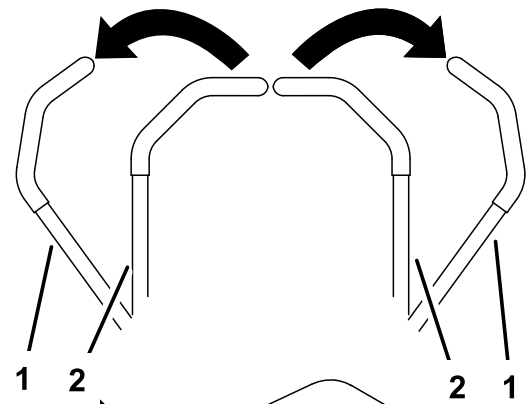

G004532

g004532

Figure 19

- | | |
|---|-------------------------|
| 1. Motion-control lever—NEUTRAL-LOCK position | 4. Backward |
| 2. Center, unlocked position | 5. Front of the machine |
| 3. Forward | |

Disengaging the Blade-Control Switch (PTO)

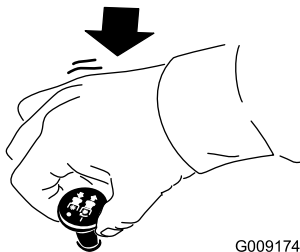

G009174

g009174

Figure 18

Driving the Machine

The throttle control regulates the engine speed as measured in rpm (revolutions per minute). Place the throttle control in the FAST position for best performance. Always operate in the full-throttle position when mowing.

⚠ CAUTION

Machine can spin very rapidly. Operator may lose control of machine and cause personal injury or damage to machine.

- Use caution when making turns.
- Slow the machine down before making sharp turns.

Using the Motion-Control Levers

Use the motion-control levers as shown in [Figure 19](#).

Driving Forward

Note: The engine kills if the traction-control levers are moved with the parking brake engaged.

1. Release the parking brake.
2. Move the levers to the center, unlocked position.
3. To move forward, slowly push the motion-control levers forward ([Figure 20](#)).

Stopping the Machine

⚠ WARNING

Children or bystanders may be injured if they move or attempt to operate the machine while it is unattended.

Always remove the ignition key and move the motion-control levers outward to the PARK position when leaving the machine unattended, even if just for a few minutes.

To stop the machine, move the traction-control levers to the NEUTRAL position and move to the locked position, disengage the blade-control switch (PTO), and turn the ignition key to the OFF position.

Set the parking brake when you leave the machine. Remember to remove the key from the ignition switch.

Adjusting the Height of Cut

The machine is equipped with a foot pedal deck-lift system. The operator can use the foot pedal to lift the deck briefly to avoid obstacles or lock the deck in the highest height of cut or transport position. The operator can use the height-of-cut lever with the foot pedal to lock the deck in a specific cutting height.

Using the Foot Pedal Deck-Lift System

- Press the pedal down to raise the deck; continue to press the pedal until the deck is locked in the transport position (Figure 22).
- Push on the deck-lift pedal with your foot and pull the transport lock handle rearward to disengage the transport lock (Figure 22).

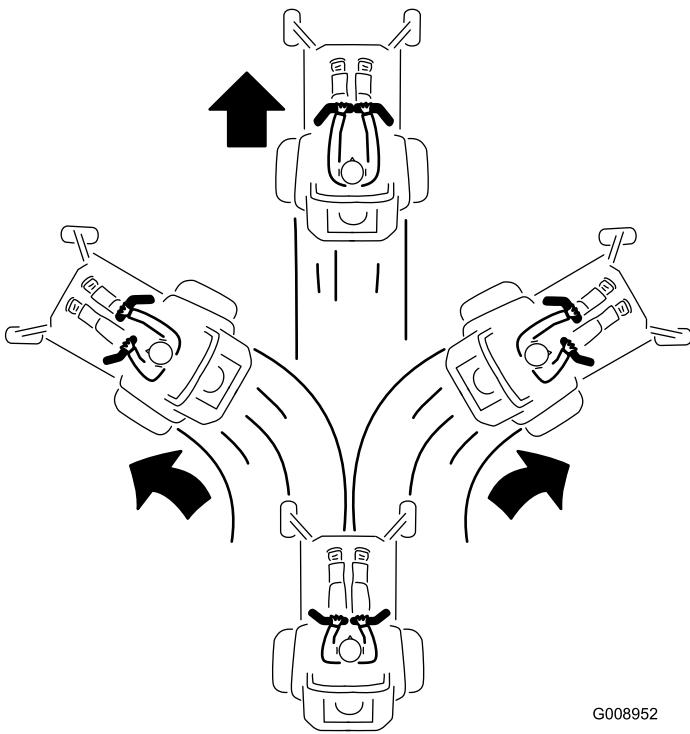

Figure 20

G008952
g008952

Driving Backward

Note: Always use caution when backing up and turning.

1. Move the levers to the center, unlocked position.
2. To go backward, slowly pull the motion-control levers rearward (Figure 21).

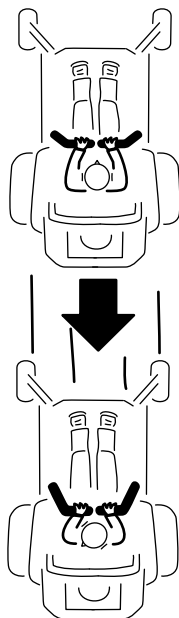
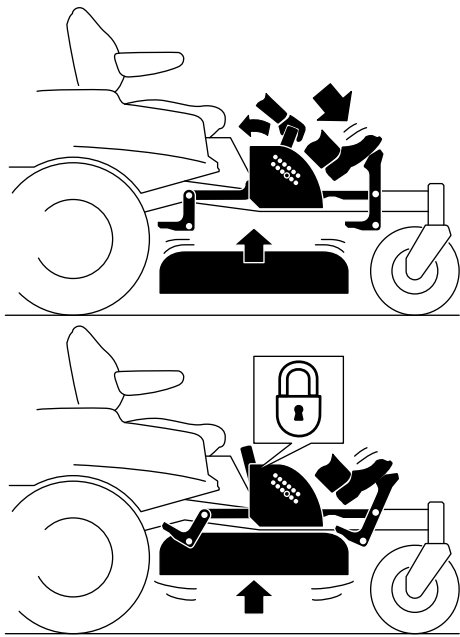

Figure 21

G008953
g008953



g024409

Figure 22

Transport Lock Position

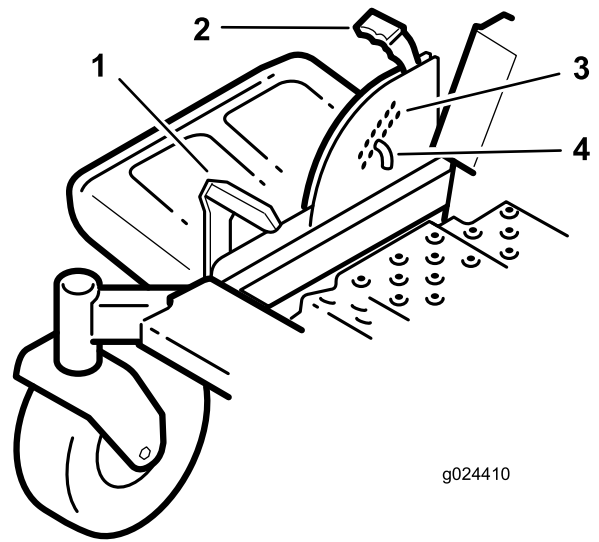

g024410

Figure 23

- | | |
|--------------------|----------------------------|
| 1. Deck-lift pedal | 3. Height-of-cut positions |
| 2. Handle | 4. Pin |

g024410

Adjusting the Height of Cut

The height of cut can be adjusted from 38 to 114 mm (1-1/2 to 4-1/2 inch) in 6 mm (1/4 inch) increments by relocating the height-of-cut pin into different hole locations.

1. Push on the deck-lift pedal with your foot and raise the mower deck to the transport-lock position (also the 114 mm (4-1/2 inch) cutting height position) as shown in [Figure 23](#).
2. To adjust, remove the pin from the height-of-cut bracket ([Figure 23](#)).
3. Select a hole in the height-of-cut system corresponding to the desired height of cut and insert the pin ([Figure 23](#)).
4. Push on the deck-lift pedal with your foot and pull the handle rearward to disengage the transport lock ([Figure 22](#)).
5. Lower the deck slowly until the lever makes contact with the pin.

Adjusting the Anti-Scalp Rollers

Whenever you change the height of cut, it is recommended to adjust the height of the anti-scalp rollers.

1. Disengage the blade-control switch (PTO), move the motion-control levers to the NEUTRAL-LOCK position, and set the parking brake.
2. Shut off the engine, remove the key, and wait for all moving parts to stop before leaving the operating position.
3. Remove the flange nut, anti-scalp roller, and bolt from the bracket ([Figure 24](#)).

Note: Keep the bolt and anti-scalp roller together when removing.

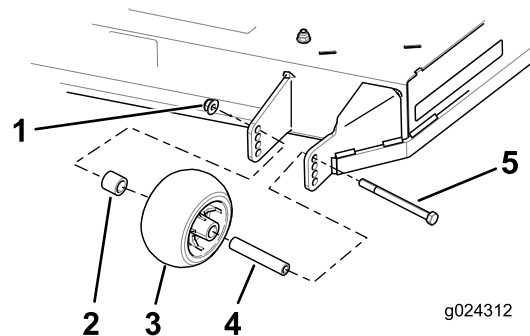

g024312

Figure 24

- | | |
|----------------------|------------|
| 1. Flange nut | 4. Bushing |
| 2. Spacer | 5. Bolt |
| 3. Anti-scalp roller | |

g024312

- Align the bolt and anti-scalp roller in the hole of the bracket that matched the closest height-of-cut position (Figure 24).
- Insert the bolt into the bracket hole and secure the bolt and anti-scalp roller with the flange nut (Figure 24).

Positioning the Seat

The seat can move forward and backward (Figure 25). Position the seat where you have the best control of the machine and are most comfortable.

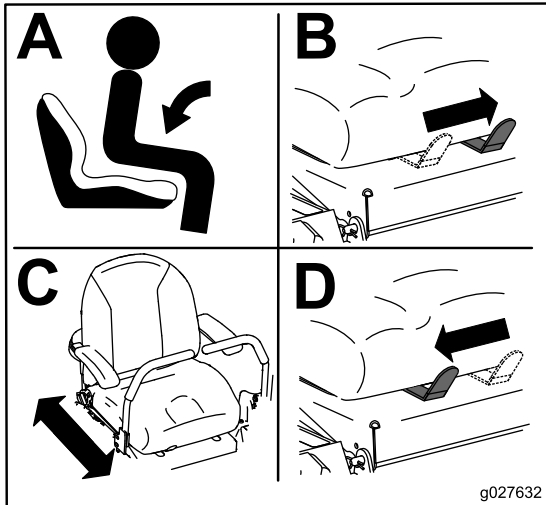

Figure 25

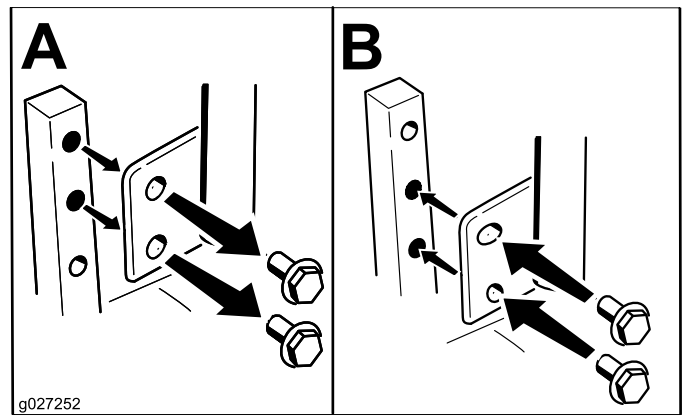

Figure 26

Adjusting the Tilt

The motion-control levers can be tilted forward or rearward for maximum operator comfort.

- Loosen the upper bolt holding the control lever to the control-arm shaft.
- Loosen the lower bolt just enough to pivot the control lever forward or rearward.
- Tighten both bolts to secure the control in the new position.
- Repeat the adjustment for the opposite control lever.

Adjusting the Motion-Control Levers

Adjusting the Height

Note: Repeat the adjustment for the opposite control lever.

The motion-control levers can be adjusted higher or lower for maximum operator comfort (Figure 26).

Pushing the Machine by Hand

Important: Always push the machine by hand. Never tow the machine because damage may occur.

- Park the machine on a level surface and disengage the blade control switch.
- Move the motion control levers outward to neutral lock position, shut off the engine, remove the key, and wait for all moving parts to stop before leaving the operating position. Make sure the parking brake is **disengaged**.
- Do this procedure on each side of the machine Figure 27.

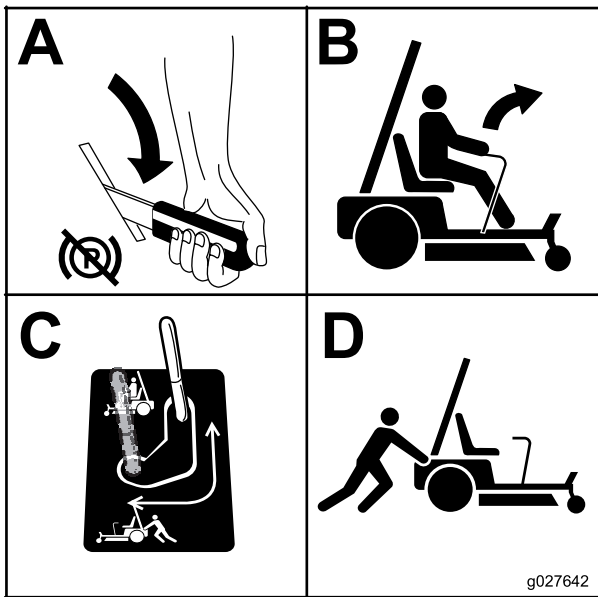

Figure 27

g027642

4. Move the bypass to the position for operating the machine (Figure 27) to engage the wheel motors.

Converting the 48-Inch Mower to Side Discharge

The mower deck and mower blades shipped with this machine were designed for optimum mulching and side-discharge performance.

Install the fasteners into the same holes in the deck that they were originally removed from. This ensure no holes are left open when the deck is operated.

⚠ DANGER

Open holes in the mower expose you and others to thrown debris. Debris thrown out of holes in the mower can cause injury.

- Never operate the mower without hardware mounted in all holes in the mower.
- Install hardware in mounting holes when the baffle is removed.

Removing the Mulching Baffle

1. Park the machine on a level surface and disengage the blade-control switch.
2. Move the motion-control levers outward to the NEUTRAL-LOCK position, set the parking brake, shut off the engine, remove the key, and wait for all moving parts to stop before leaving the operating position.
3. Remove the mower; refer to [Removing the Mower \(page 51\)](#).
4. Turn the mower upside down.
5. Remove the 2 locknuts (5/16 inch) secured to the welded posts of the left baffle on the top of the mower deck at the center and left of center positions (Figure 28).

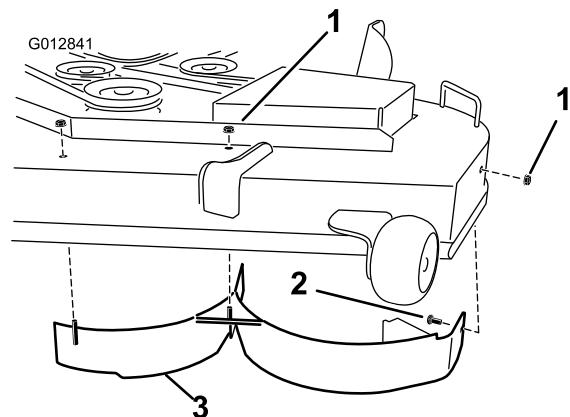

Figure 28

g012841

1. Locknut (5/16 inch)
2. Carriage bolt (5/16 x 3/4 inch)
3. Left baffle

6. Remove the carriage bolt and locknut on the side wall of the mower deck securing the left baffle to the deck.
7. Remove the left baffle from the mower deck as shown in [Figure 28](#).
8. Remove the carriage bolt (5/16 x 3/4 inch) and locknut (5/16 inch) on the rear wall of the mower deck securing the baffle to the deck ([Figure 29](#)).

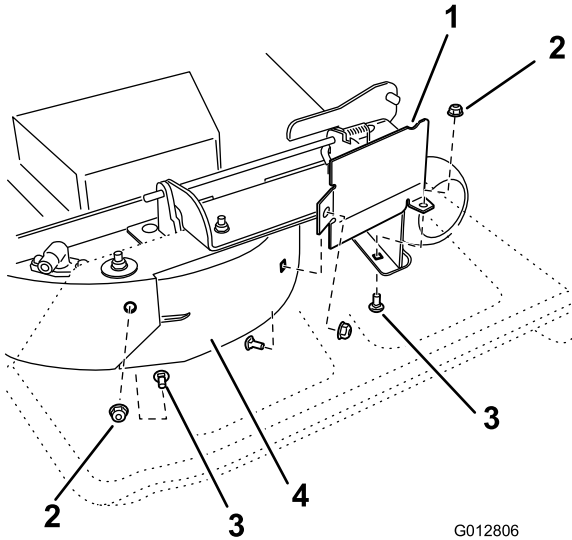

Figure 29

- | | |
|------------------------|------------------------------------|
| 1. Baffle guard | 3. Carriage bolt (5/16 x 3/4 inch) |
| 2. Locknut (5/16 inch) | 4. Right baffle |

9. Locate the baffle guard at the front edge of the side discharge opening and remove the fasteners securing the baffle guard and the right baffle to the mower deck ([Figure 29](#)).

Note: Remove the baffle guard and retain all fasteners.

10. Remove the 2 locknuts (5/16 inch) to securing the welded posts of the right baffle to the top of the mower deck at center and right of center positions ([Figure 30](#)).

Note: Remove the right baffle from the mower deck.

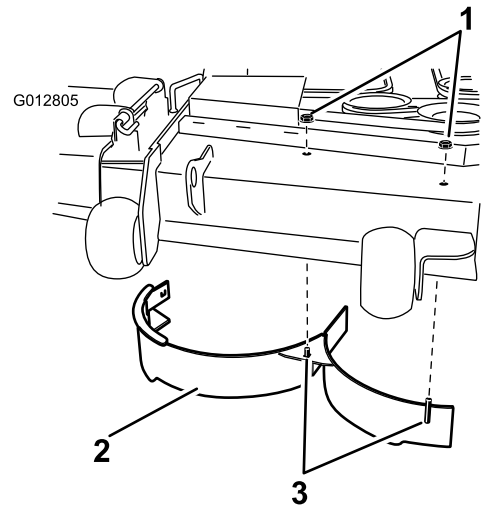

Figure 30

- | | |
|------------------------|-------------------------------|
| 1. Locknut (5/16 inch) | 3. Welded posts, right baffle |
| 2. Right baffle | |

11. Locate the cutoff baffle in the loose parts bag and remove the fasteners at the rear holes of the discharge plate ([Figure 31](#)).

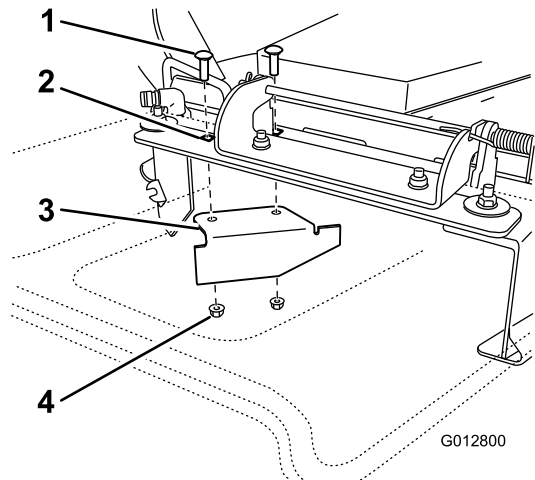

Figure 31

- | | |
|--------------------------------------|---------------------------------|
| 1. Carriage bolt, existing | 3. Cutoff baffle, shipped loose |
| 2. Rear holes in the discharge plate | 4. Locknut, existing |

12. Install the baffle at the side discharge opening on the mower deck.
13. Use the fasteners removed to secure the cutoff baffle to the deck.
14. Install the mower; refer to [Installing the Mower Deck \(page 52\)](#).

Converting the 54-Inch Mower to Side Discharge

Install the fasteners into the same holes in the deck as they were originally removed from. This ensures that no holes are left open when the deck is operated.

⚠ DANGER

Open holes in the mower expose you and others to thrown debris. Debris thrown out of holes in the mower can cause injury.

- Never operate the mower without hardware mounted in all holes in the mower.
- Install hardware in mounting holes when the baffle is removed.

Removing the Mulching Baffle

1. Park the machine on a level surface and disengage the blade-control switch.
2. Move the motion-control levers outward to the NEUTRAL-LOCK position, set the parking brake, shut off the engine, remove the key, and wait for all moving parts to stop before leaving the operating position.
3. Remove the mower; refer to [Removing the Mower](#) (page 51).
4. Turn the mower upside down.
5. Remove the 3 locknuts (5/16 inch) secured to the welded posts of the left baffle on the top of the mower deck at the center, left of center and left positions ([Figure 32](#)).

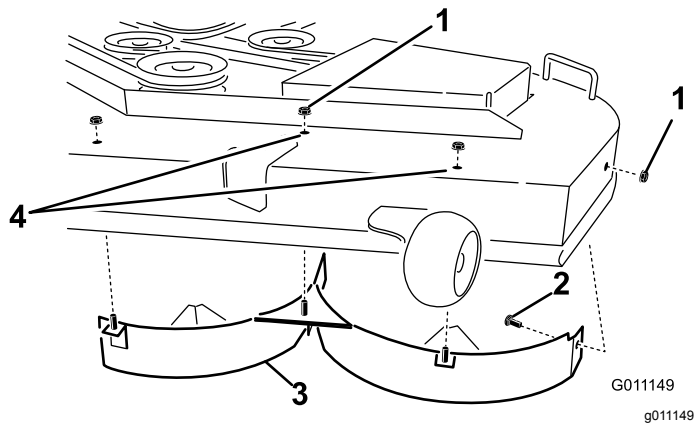

Figure 32

- | | |
|------------------------------------|---------------------------|
| 1. Locknut (5/16 inch) | 3. Left baffle |
| 2. Carriage bolt (5/16 x 3/4 inch) | 4. Install fasteners here |

6. Remove the carriage bolt and locknut on the side wall of the mower deck securing the left baffle to the deck ([Figure 32](#)).

7. Remove the left baffle from the mower deck ([Figure 32](#)).
8. Locate the 2 bolts in loose parts and use the existing locknuts and install these fasteners into the holes shown in [Figure 32](#) on the mower deck to prevent flying debris.

Note: Install the bolt up, through the underside of the deck and use an existing locknut to secure from the topside.

⚠ WARNING

Open holes in the mower expose you and others to thrown debris which can cause severe injury.

- Never operate the mower without hardware mounted in all holes in the mower housing.
- Install the hardware in the mounting holes when you remove the mulching baffle.

9. Remove the carriage bolt (5/16 x 3/4 inch) and locknut (5/16 inch) on the rear wall of the mower deck securing the baffle to the deck ([Figure 33](#)).

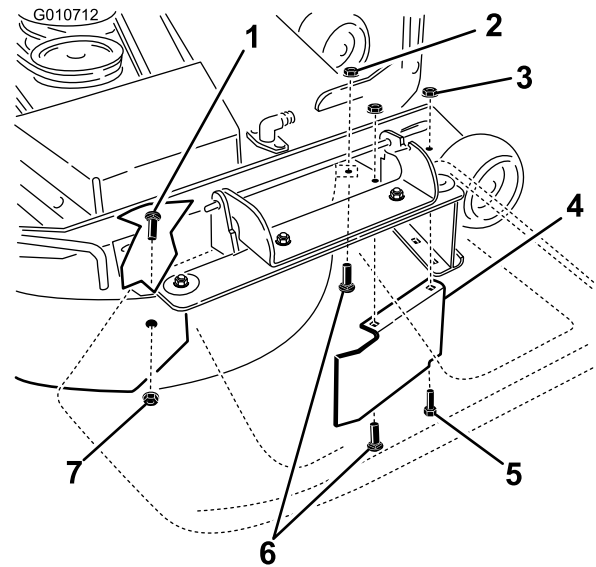

Figure 33

- | | |
|--|---|
| 1. Carriage bolt (5/16 x 3/4 inch) | 5. Hex-head bolt, forward hole in deck (reinstall after baffle is removed) |
| 2. Locknut, front of discharge plate (reinstall after baffle is removed) | 6. Carriage bolts, front of discharge plate (reinstall after baffle is removed) |
| 3. Locknut, forward hole in deck (reinstall after baffle is removed) | 7. Locknut (5/16 inch) |
| 4. Baffle guard, 54 inch decks | |

10. Locate the baffle guard at the front edge of the side discharge opening (Figure 33).
11. Remove the fasteners securing the baffle guard and the right baffle to the mower deck (Figure 33).

Note: Remove the baffle guard and retain all fasteners.
12. Remove the 2 locknuts (5/16 inch) securing the welded posts of the right baffle to the top of the mower deck at center and right of center positions (Figure 34).

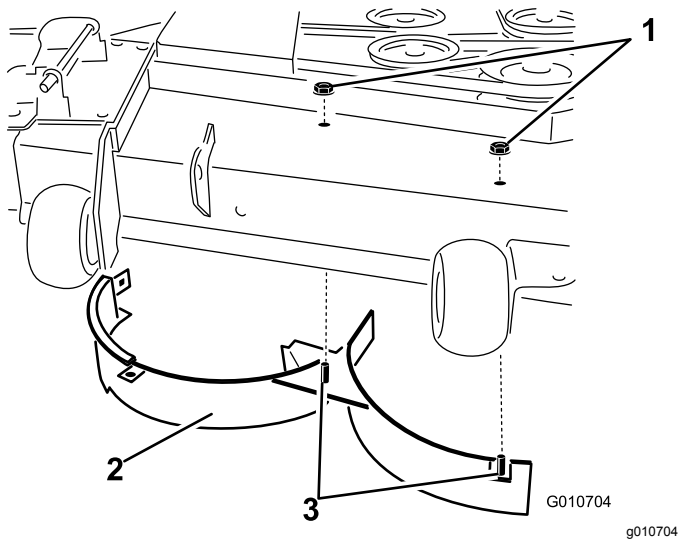

Figure 34

- | | |
|------------------------|-------------------------------|
| 1. Locknut (5/16 inch) | 3. Welded posts, right baffle |
| 2. Right baffle | 4. Carriage bolt |

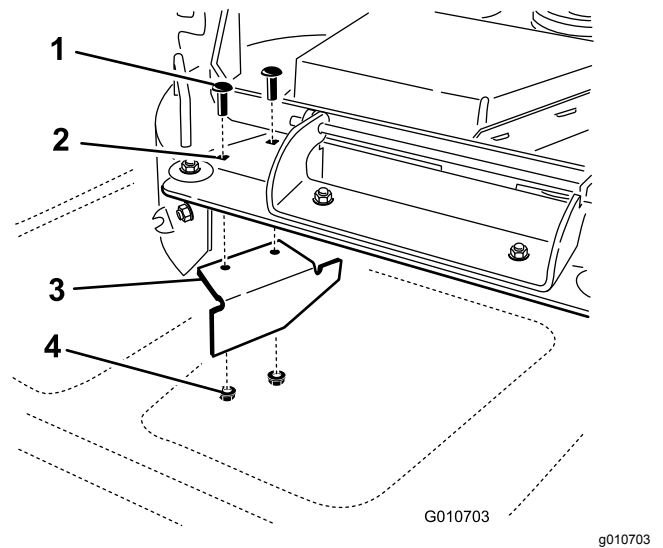

Figure 35

- | | |
|--------------------------------------|------------------|
| 1. Carriage bolt | 3. Cutoff baffle |
| 2. Rear holes in the discharge plate | 4. Locknut |

16. Use the fasteners removed to secure the cutoff baffle to the deck.
17. Install the mower; refer to [Installing the Mower Deck](#) (page 52).

Using the Side Discharge

The mower has a hinged grass deflector that disperses clippings to the side and down toward the turf.

⚠ DANGER

Without a grass deflector, discharge cover, or complete grass catcher assembly mounted in place, you and others are exposed to blade contact and thrown debris. Contact with rotating mower blade(s) and thrown debris will cause injury or death.

- **Never remove the grass deflector from the mower because the grass deflector routes material down toward the turf. If the grass deflector is ever damaged, replace it immediately.**
- **Never put your hands or feet under the mower.**
- **Never try to clear the discharge area or mower blades unless you move the blade-control switch (PTO) to the OFF position, rotate the ignition key to the OFF position, and remove the key.**
- **Make sure that the grass deflector is in the down position.**

Transporting the Machine

Use a heavy-duty trailer or truck to transport the machine. Ensure that the trailer or truck has all necessary brakes, lighting, and marking as required by law. Please carefully read all the safety instructions. Knowing this information could help you, your family, pets, or bystanders avoid injury.

⚠ WARNING

Driving on the street or roadway without turn signals, lights, reflective markings, or a slow-moving-vehicle emblem is dangerous and can lead to accidents, causing personal injury.

Do not drive the machine on a public street or roadway.

1. If you are using a trailer, connect it to the towing vehicle and connect the safety chains.
2. If applicable, connect the trailer brakes.
3. Load the machine onto the trailer or truck.
4. Shut off the engine, remove the key, set the brake, and close the fuel valve.
5. Tie down the machine near the front caster wheels and the rear bumper (Figure 36).

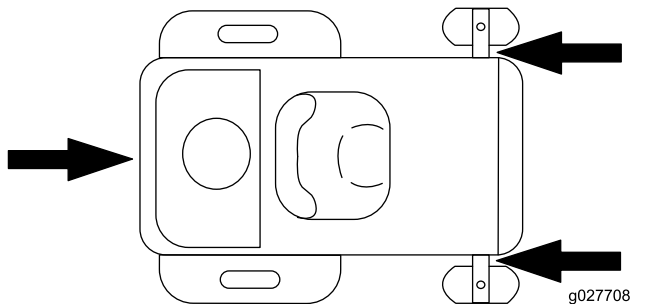

Figure 36

Loading the Machine

Use extreme caution when loading or unloading machines onto a trailer or a truck. Use a full-width ramp that is wider than the machine for this procedure. Back the machine up the ramp and drive it forward down the ramp (Figure 37).

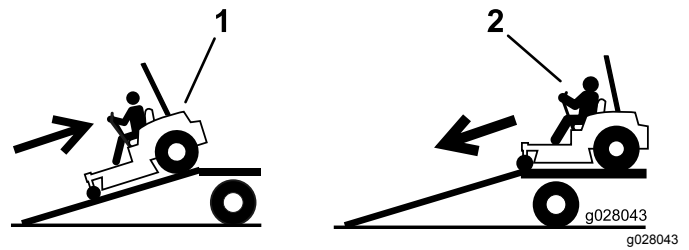

Figure 37

1. Back the machine up the ramp.
2. Drive the machine forward down the ramp.

Important: Do not use narrow individual ramps for each side of the machine.

Ensure the ramp is long enough so that the angle with the ground does not exceed 15 degrees (Figure 38). On flat ground, this requires a ramp to be at least 4 times as long as the height of the trailer or truck bed to the ground. A steeper angle may cause mower components to get caught as the unit moves from the ramp to the trailer or truck. Steeper angles may also cause the machine to tip or lose control. If loading on or near a slope, position the trailer or truck so that it is on the down side of the slope and the ramp extends up the slope. This will minimize the ramp angle.

⚠ WARNING

Loading a machine onto a trailer or truck increases the possibility of tip-over and could cause serious injury or death.

- Use extreme caution when operating a machine on a ramp.
- Use only a full-width ramp; do not use individual ramps for each side of the machine.
- Do not exceed a 15-degree angle between the ramp and the ground or between the ramp and the trailer or truck.
- Ensure the length of ramp is at least 4 times as long as the height of the trailer or truck bed to the ground. This will ensure that ramp angle does not exceed 15 degrees on flat ground.
- Back up ramps and drive forward down ramps.
- Avoid sudden acceleration or deceleration while driving the machine on a ramp as this could cause a loss of control or a tip-over situation.

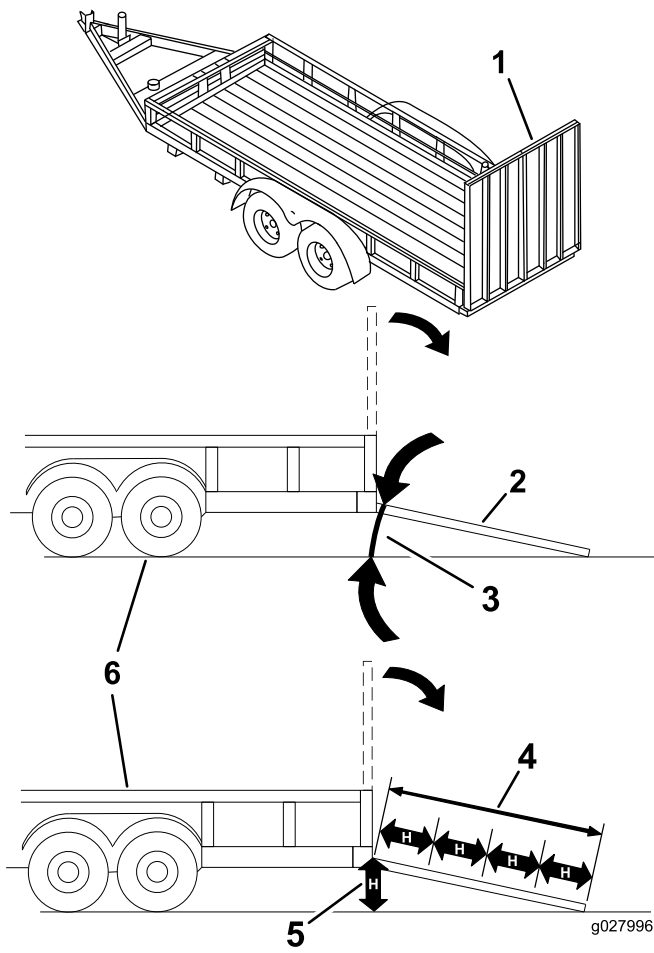

Figure 38

- | | |
|---|---|
| 1. Full-width ramp in stowed position | 4. Ramp is at least 4 times as long as the height of the trailer or truck bed to the ground |
| 2. Side view of full-width ramp in loading position | 5. H= height of the trailer or truck bed to the ground |
| 3. Not greater than 15 degrees | 6. Trailer |

Operating Tips

Using the Fast Throttle Setting

For best mowing and maximum air circulation, operate the engine at the FAST position. Air is required to thoroughly cut grass clippings, so do not set the height-of-cut so low as to totally surround the mower in uncut grass. Always try to have 1 side of the mower free from uncut grass, which allows air to be drawn into the mower.

Cutting a Lawn for the First Time

Cut grass slightly longer than normal to ensure that the cutting height of the mower does not scalp any uneven ground. However, the cutting height used in the past is generally the best one to use. When cutting grass longer than 15 cm (6 inches) tall, you may want to cut the lawn twice to ensure an acceptable quality of cut.

Cutting a Third of the Grass Blade

It is best to cut only about 1/3 of the grass blade. Cutting more than that is not recommended unless grass is sparse, or it is late fall when grass grows more slowly.

Alternating the Mowing Direction

Alternate the mowing direction to keep the grass standing straight. This also helps disperse clippings which enhances decomposition and fertilization.

Mowing at Correct Intervals

Normally, mow every 4 days. But, remember, grass grows at different rates at different times. So to maintain the same cutting height, which is a good practice, and mow more often in early spring. As the grass growth rate slows in mid summer, mow less frequently. If you cannot mow for an extended period, first mow at a high cutting height, then mow again 2 days later at a lower height setting.

Using a Slower Cutting Speed

To improve cut quality, use a slower ground speed in certain conditions.

Avoiding Cutting Too Low

If the cutting width of the mower is wider than the mower you previously used, raise the cutting height to ensure that uneven turf is not cut too short.

Cutting Long Grass

If the grass is ever allowed to grow slightly longer than normal, or if it contains a high degree of moisture, raise the cutting height higher than usual and cut the grass at this setting. Then cut the grass again using the lower, normal setting.

Stopping

If you must stop the forward motion of the machine while mowing, a clump of grass clippings may drop onto your lawn. To avoid this, move onto a previously cut area with the blades engaged or you can disengage the mower deck while moving forward.

Keeping the Underside of the Mower Clean

Clean clippings and dirt from the underside of the mower after each use. If grass and dirt build up inside the mower, cutting quality will eventually become unsatisfactory.

Maintaining the Blade(s)

Maintain a sharp blade throughout the cutting season because a sharp blade cuts cleanly without tearing or shredding the grass blades. Tearing and shredding turns grass brown at the edges, which slows growth and increases the chance of disease. Check the mower blades after each use for sharpness, and for any wear or damage. File down any nicks and sharpen the blades as necessary. If a blade is damaged or worn, replace it immediately with a genuine Toro replacement blade.

Maintenance

Recommended Maintenance Schedule(s)

Maintenance Service Interval	Maintenance Procedure
After the first 8 hours	<ul style="list-style-type: none">• Change the engine oil.
After the first 50 hours	<ul style="list-style-type: none">• Change the hydraulic filter and fluid.
Before each use or daily	<ul style="list-style-type: none">• Check the safety-interlock system.• Clean and check the air-cleaner element.• Check the engine-oil level.• Clean the air-intake screen.• Check the mower blades.• Inspect the grass deflector for damage.
After each use	<ul style="list-style-type: none">• Clean the mower housing.
Every 25 hours	<ul style="list-style-type: none">• Grease all lubrication points.• Check tire pressure.• Check the hydraulic-fluid level in the expansion tank.
Every 50 hours	<ul style="list-style-type: none">• Inspect the belts for cracks and wear.
Every 100 hours	<ul style="list-style-type: none">• Service the paper element (more often in dusty, dirty conditions).• Change the engine oil (more often in dusty, dirty conditions).• Check the spark plug(s).• Replace the fuel filters (more often under dusty, dirty conditions).
Every 200 hours	<ul style="list-style-type: none">• Replace the paper element (more often in dusty, dirty conditions).• Change the engine-oil filter (more often in dusty, dirty conditions).
Every 400 hours	<ul style="list-style-type: none">• Change the hydraulic filter and fluid.
Monthly	<ul style="list-style-type: none">• Check the battery charge.
Yearly or before storage	<ul style="list-style-type: none">• Paint chipped surfaces.• Check all maintenance procedures listed above before storage.

Important: Refer to your engine operator's manual for additional maintenance procedures.

⚠ CAUTION

If you leave the key in the ignition switch, someone could accidentally start the engine and seriously injure you or other bystanders.

Remove the key from the ignition and disconnect the wire from the spark plug before you do any maintenance. Set the wire aside so that it does not accidentally contact the spark plug.

Pre-Maintenance Procedures

Service-Interval Chart

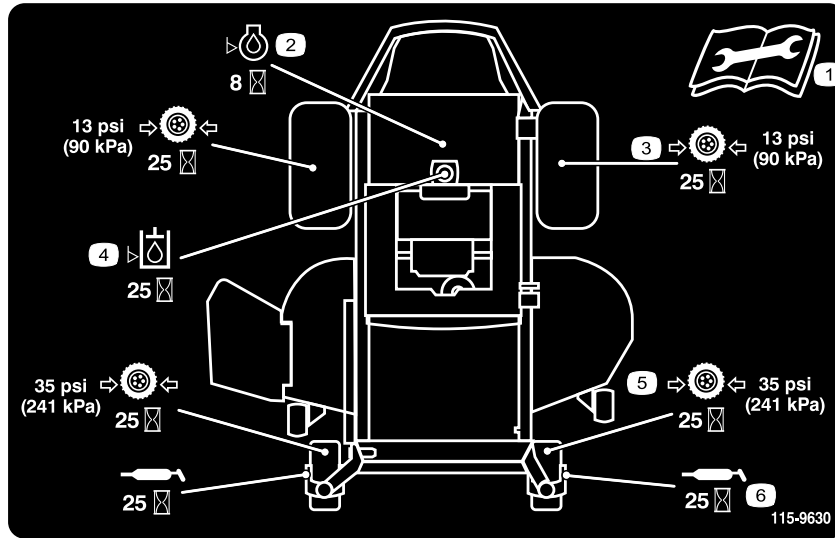

decal115-9630

Figure 39

Located on the seat pan underside

1. Read the *Operator's Manual* before performing any maintenance.
2. Check the engine oil every 8 hours.
3. Check the drive wheel tire pressure every 25 hours.
4. Check the hydraulic oil every 25 hours.
5. Check the caster wheel tire pressure every 25 hours.
6. Lubricate the caster wheel every 25 hours.

Raising the Seat

Ensure that the motion-control levers are locked in the NEUTRAL-LOCK position and lift the seat forward.

The following components can be accessed by raising the seat:

- Service decal
- Fuses
- Battery and cables

Releasing the Mower-Deck Curtain

Loosen the 2 bottom bolts of the curtain to gain access to the top of the mower deck ([Figure 40](#)).

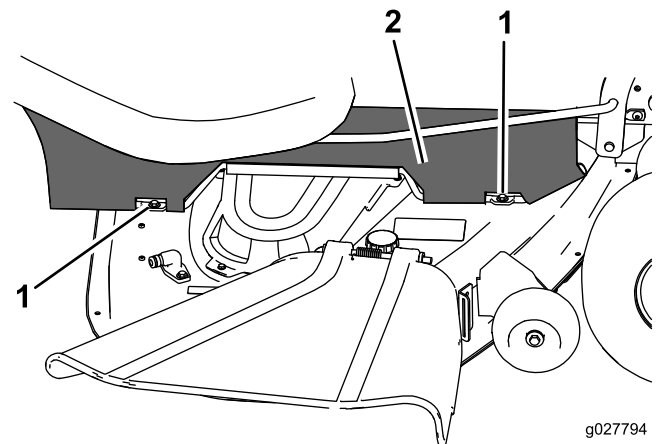

g027794

g027794

Figure 40

1. Bottom bolt
2. Curtain

Lubrication

Greasing the Bearings

Service Interval: Every 25 hours—Grease all lubrication points.

Grease Type: No. 2 lithium grease

1. Park the machine on a level surface and disengage the blade-control switch.
2. Move the motion-control levers outward to the NEUTRAL-LOCK position, shut off the engine, remove the key, and wait for all moving parts to stop before leaving the operating position.
3. Clean the grease fittings (Figure 41 and Figure 39) with a rag.

Note: Make sure to scrape any paint off the front of the fitting(s).

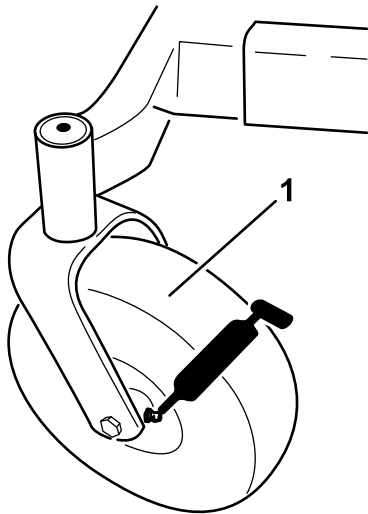

Figure 41

1. Front caster tire

-
4. Connect a grease gun to each fitting and pump grease into the fittings until grease begins to ooze out of the bearings (Figure 39 and Figure 41).

Engine Maintenance

⚠ WARNING

Contact with hot surfaces may cause personal injury.

Keep hands, feet, face, clothing and other body parts away the muffler and other hot surfaces.

Servicing the Air Cleaner

Service Interval: Before each use or daily—Clean and check the air-cleaner element.

Note: Service the air cleaner more frequently if the operating conditions are extremely dusty or sandy.

Removing the Element

1. Park the machine on a level surface and disengage the blade-control switch (PTO).
2. Move the motion-control levers to the NEUTRAL-LOCK position, set the parking brake, shut off the engine, remove the key, and wait for all moving parts to stop before leaving the operating position.
3. Clean around the air-cleaner cover to prevent dirt from getting into the engine and causing damage and lift the cover and remove the hose clamp securing the air cleaner assembly to the engine (Figure 42).
4. Loosen the hose clamp and remove the paper element (Figure 42).

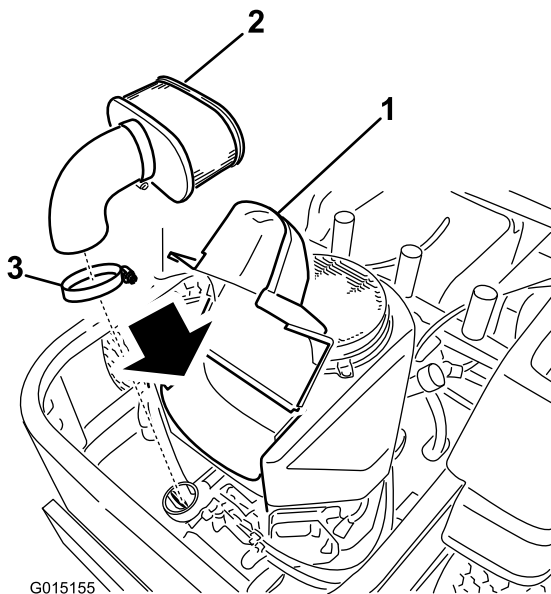

Figure 42

1. Cover
2. Paper element
3. Hose clamp

Cleaning the Element

Service Interval: Every 100 hours—Service the paper element (more often in dusty, dirty conditions).

Every 200 hours/Yearly (whichever comes first)—Replace the paper element (more often in dusty, dirty conditions).

1. Lightly tap the element on a flat surface to remove dust and dirt.
2. Inspect the element for tears, an oily film, and damage to the seal.

Important: Never clean the paper element with pressurized air or liquids, such as solvent, gas, or kerosene. Replace the paper element if it is damaged or cannot be cleaned thoroughly.

Servicing the Engine Oil

Oil Type: Detergent oil (API service SF, SG, SH, SJ, or SL)

Crankcase Capacity: 1.8 L (61 oz); when oil filter is removed: 2.1 L (70 oz)

Viscosity: See the table below.

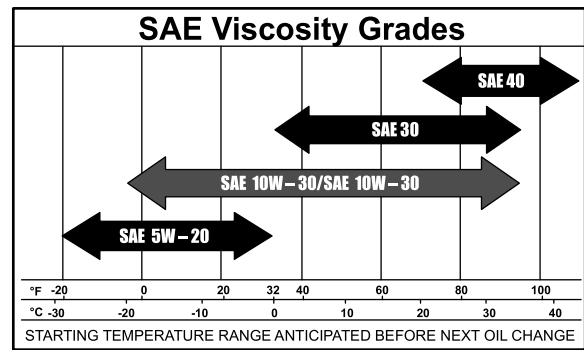

G010686

g010686

Figure 43

Note: Using multi grade oils (5W-20, 10W-30, and 10W-40) will increase oil consumption. Check oil level more frequently when using them.

Checking the Engine-Oil Level

Service Interval: Before each use or daily

Note: Check the oil when the engine is cold.

⚠ WARNING

Contact with hot surfaces may cause personal injury.

Keep hands, feet, face, clothing and other body parts away the muffler and other hot surfaces.

Important: Do not overfill the crankcase with oil because damage to the engine may result. Do not run the engine with oil below the low mark because the engine may be damaged.

1. Park the machine on a level surface.
2. Disengage the blade-control switch (PTO).
3. Shut off the engine, wait for all moving parts to stop, and remove the key before leaving the operating position.
4. Check the engine-oil level (Figure 44).

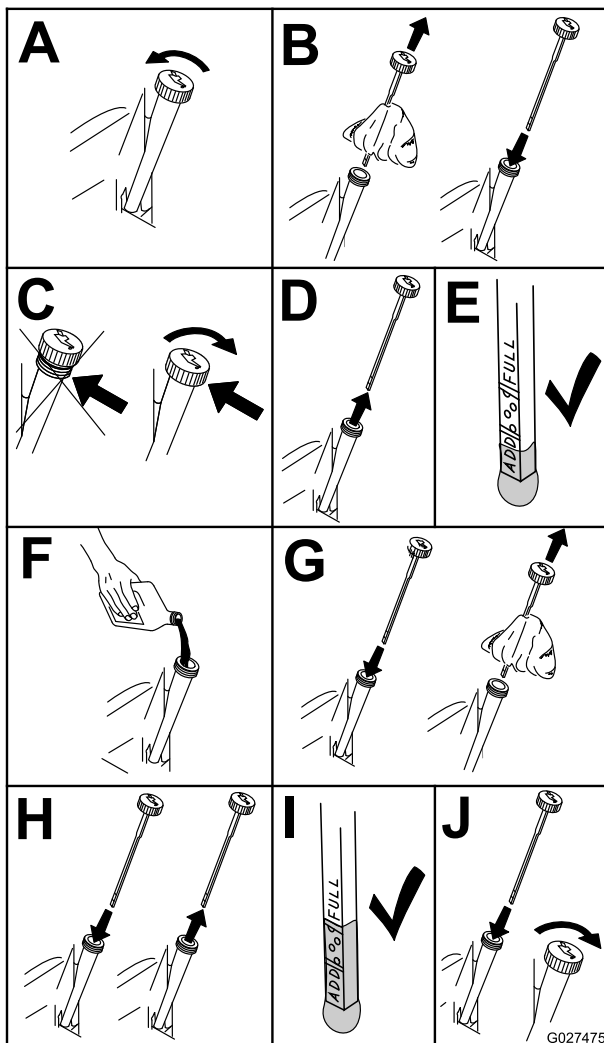

Figure 44

g027475

Changing the Engine Oil

Service Interval: After the first 8 hours—Change the engine oil.

Every 100 hours—Change the engine oil (more often in dusty, dirty conditions).

Note: Dispose of the used oil at a recycling center.

1. Park the machine so that the drain side is slightly lower than the opposite side to ensure the oil drains completely.
2. Disengage the PTO, move the motion-control levers to the NEUTRAL-LOCK position, and set the parking brake.
3. Shut off the engine, remove the key, and wait for all moving parts to stop before leaving the operating position.
4. Drain the oil from the engine (Figure 45).

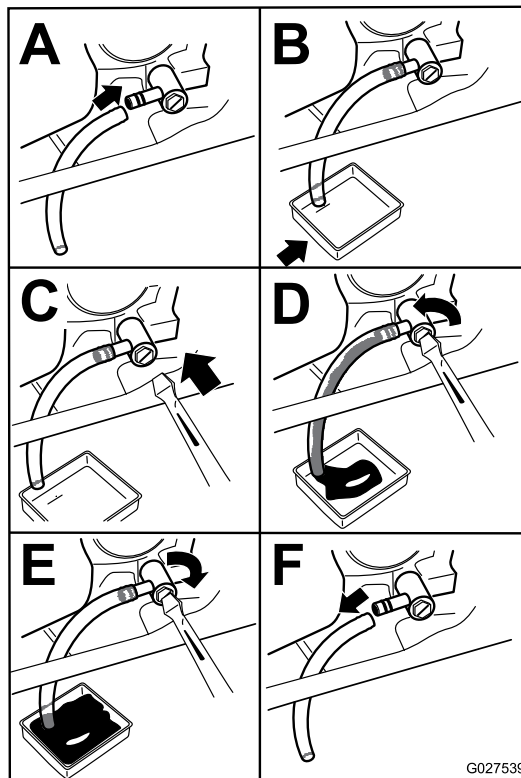

Figure 45

G027539

g027539

5. Slowly pour approximately 80% of the specified oil into the filler tube and slowly add the additional oil to bring it to the **Full** mark (Figure 46).

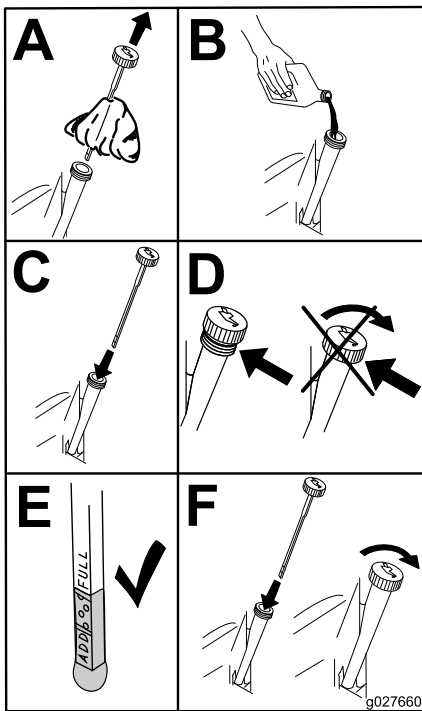

Figure 46

g027660

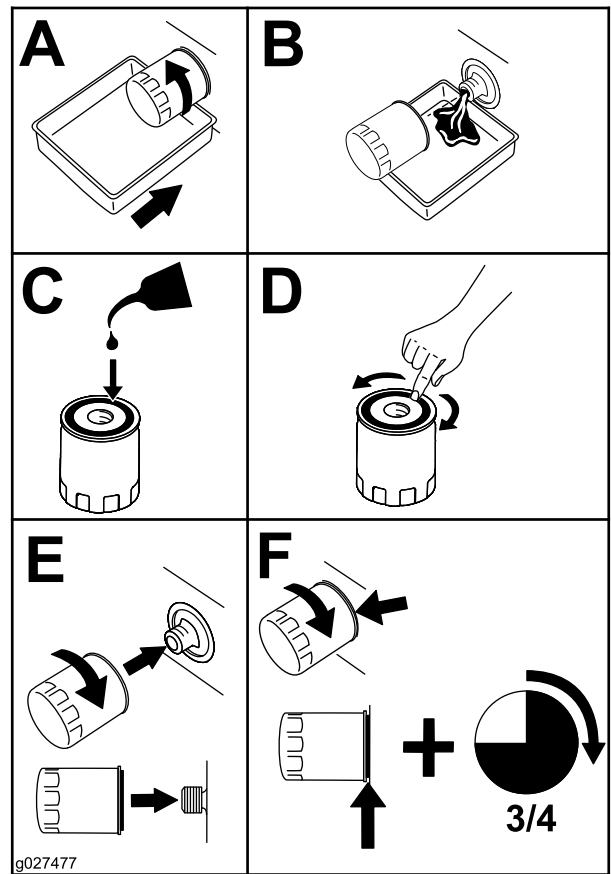

Figure 47

g027477

Changing the Engine-Oil Filter

Service Interval: Every 200 hours—Change the engine-oil filter (more often in dusty, dirty conditions).

Note: Change the engine-oil filter more frequently when operating conditions are extremely dusty or sandy.

1. Drain the oil from the engine.
2. Change the engine-oil filter (Figure 47).

Note: Ensure the oil filter gasket touches the engine and then an extra 3/4 turn is completed.

3. Fill the crankcase with the proper type of new oil.

Servicing the Spark Plug

Service Interval: Every 100 hours—Check the spark plug(s).

Make sure the air gap between the center and side electrodes is correct before installing the spark plug. Use a spark plug wrench for removing and installing the spark plug(s) and a gapping tool/feeler gauge to check and adjust the air gap. Install a new spark plug(s) if necessary.

Type: NGK BPR4ES

Air Gap: 0.76 mm (0.03 inch)

Removing the Spark Plug

1. Disengage the PTO, move the motion-control levers to the NEUTRAL-LOCK position, and set the parking brake.
2. Shut off the engine, remove the key, and wait for all moving parts to stop before leaving the operating position.

- Remove the spark plug (Figure 48).

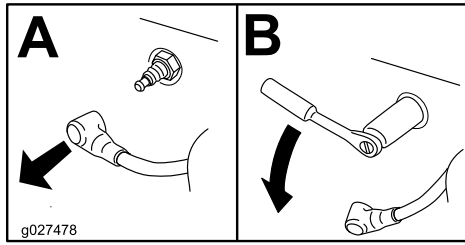

Figure 48

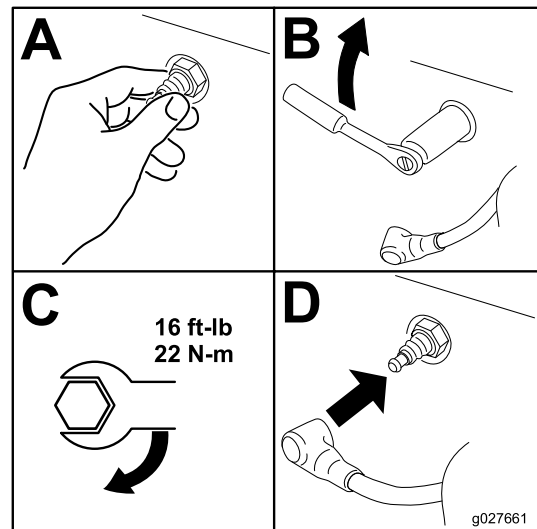

Figure 50

Checking the Spark Plug

Important: Never clean the spark plug(s). Always replace the spark plug(s) when it has: a black coating, worn electrodes, an oily film, or cracks.

If you see light brown or gray on the insulator, the engine is operating properly. A black coating on the insulator usually means the air cleaner is dirty.

Set the gap to 0.03 inches (0.76 mm).

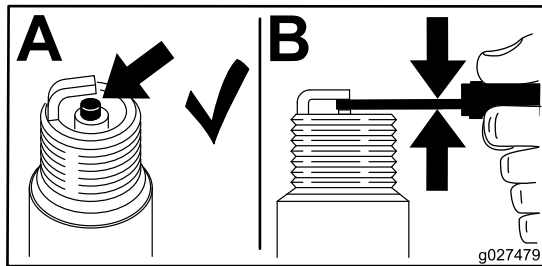

Figure 49

Installing the Spark Plug

Tighten the spark plug(s) to 22 N•m (16 ft-lb) as shown in Figure 50.

Cleaning the Cooling System

Clean the air-intake screen from grass and debris before each use.

- Disengage the blade-control switch and move the control levers to the NEUTRAL-LOCK position, and apply the parking brake.
- Shut off the engine, remove the key, and wait for all moving parts to stop before leaving the operating position.
- Remove the air-intake screen, air-cleaner cover, and fan housing.
- Clean the debris and grass from the parts.
- Install the air-intake screen, air-cleaner cover, and fan housing.

Fuel System Maintenance

Replacing the Fuel Filter

Service Interval: Every 100 hours/Yearly (whichever comes first) (more often under dusty, dirty conditions).

1. Disengage the blade-control switch (PTO), move the motion-control levers to the NEUTRAL-LOCK position, and set the parking brake.
2. Shut off the engine, remove the key, and wait for all moving parts to stop before leaving the operating position.
3. Replace the fuel filter (Figure 51).

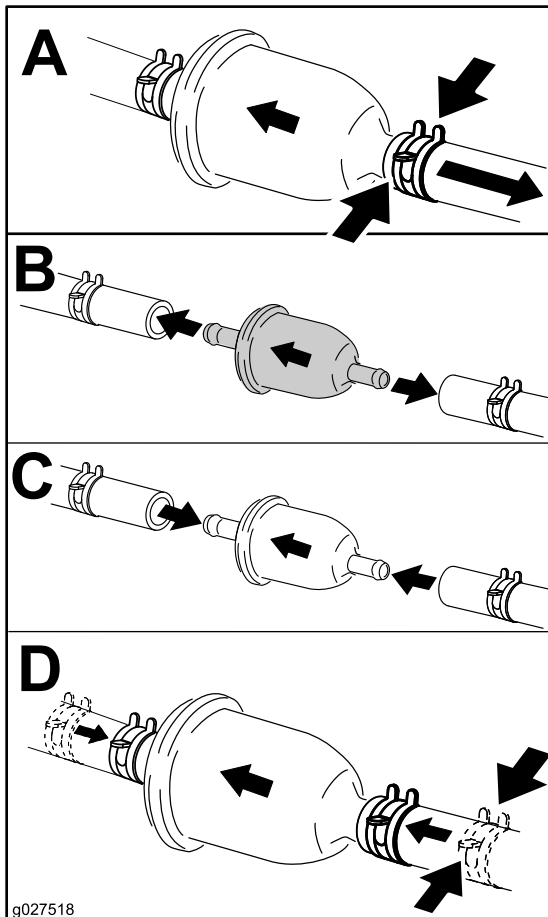
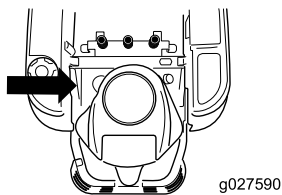

Figure 51

Electrical System Maintenance

Servicing the Battery

Service Interval: Monthly

⚠ DANGER

Battery electrolyte contains sulfuric acid which is a deadly poison and causes severe burns.

Do not drink electrolyte and avoid contact with skin, eyes or clothing. Wear safety glasses to shield your eyes and rubber gloves to protect your hands.

Removing the Battery

⚠ WARNING

Battery terminals or metal tools could short against metal machine components causing sparks. Sparks can cause the battery gasses to explode, resulting in personal injury.

- When removing or installing the battery, do not allow the battery terminals to touch any metal parts of the machine.
- Do not allow metal tools to short between the battery terminals and metal parts of the machine.

⚠ WARNING

Incorrect battery cable routing could damage the machine and cables causing sparks. Sparks can cause the battery gasses to explode, resulting in personal injury.

- Always disconnect the negative (black) battery cable before disconnecting the positive (red) cable.
- Always reconnect the positive (red) battery cable before reconnecting the negative (black) cable.

1. Disengage the blade-control switch (PTO), move the motion-control levers to the NEUTRAL-LOCK position, and set the parking brake.
2. Shut off the engine, remove the key, and wait for all moving parts to stop before leaving the operating position.
3. Remove the wing nut securing the battery clamp (Figure 52).

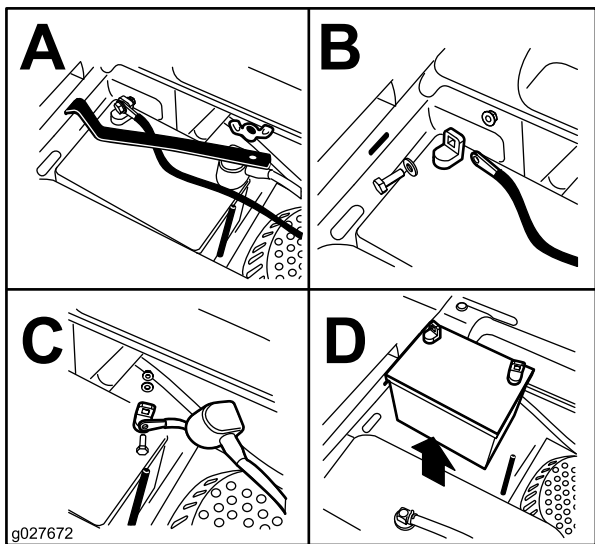

Figure 52

4. Remove the clamp (Figure 52).
5. First disconnect the negative battery cable (black) from the negative (-)(black) battery terminal (Figure 52).
6. Slide the red terminal boot off the positive (red) battery terminal and remove the positive (+)(red) battery cable (Figure 52).
7. Remove the battery.

Installing the Battery

1. Position the battery in the tray with the terminal posts opposite from the fuel tank (Figure 52).
2. Install the positive (red) battery cable to positive (+) battery terminal.
3. Install the negative battery cable to the negative (-) battery terminal.
4. Secure the cables with 2 bolts, 2 washers, and 2 locknuts (Figure 52).
5. Slide the red terminal boot onto the positive (red) battery post.
6. Install the clamp and secure it with the wing nut (Figure 52).

Charging the Battery

⚠ WARNING

Charging the battery produces gasses that can explode.

Never smoke near the battery and keep sparks and flames away from battery.

Important: Always keep the battery fully charged. This is especially important to prevent battery damage when the temperature is below 32°F (0°C).

1. Charge battery for 10 to 15 minutes at 25 to 30 amps or 30 minutes at 10 amps.
2. When the battery is fully charged, unplug the charger from the electrical outlet, then disconnect the charger leads from the battery posts (Figure 53).
3. Install the battery in the machine and connect the battery cables.

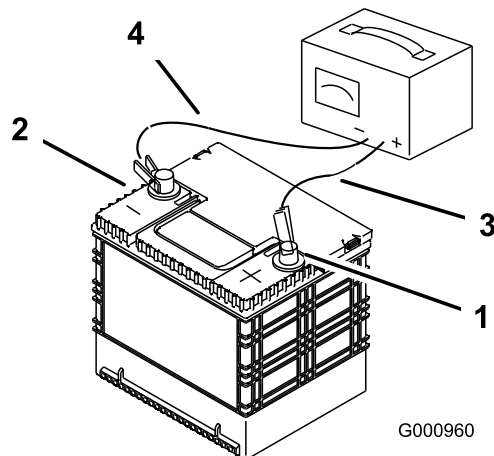

Figure 53

1. Positive battery post
2. Negative battery post
3. Red (+) charger lead
4. Black (-) charger lead

Servicing the Fuses

The electrical system is protected by fuses. It requires no maintenance; however, if a fuse blows, check the component/circuit for a malfunction or short.

Note: The fuses are located on right hand console next to the seat (Figure 54).

Fuse type:

- Main—30 A, blade-type
- Engine—20 A, blade-type

1. To replace the main fuse, grasp the fuse and pull it straight and away from the fuse block (Figure 54).

Drive System Maintenance

Checking the Tire Pressure

Service Interval: Every 25 hours—Check tire pressure.

Maintain the air pressure in the front and rear tires as specified. Uneven tire pressure can cause uneven cut. Check the pressure at the valve stem (Figure 56). Check the tires when they are cold to get the most accurate pressure reading.

Refer to the maximum pressure suggested by the tire manufacturer on the sidewall of the caster wheel tires.

Inflate the rear drive wheel tires to 90 kPa (13 psi).

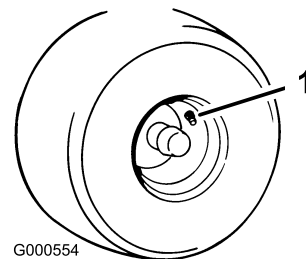

Figure 56

1. Valve stem

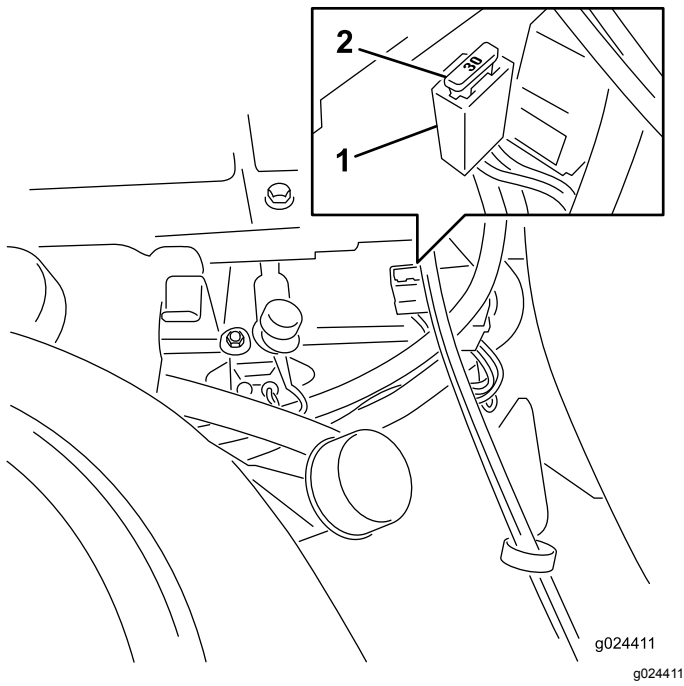

Figure 54

1. Fuse block
2. Main—30 A

Important: Ensure that the new fuses are the same type and amperage as the fuses removed.

2. To replace the engine fuse, remove the console from the plastic fender.

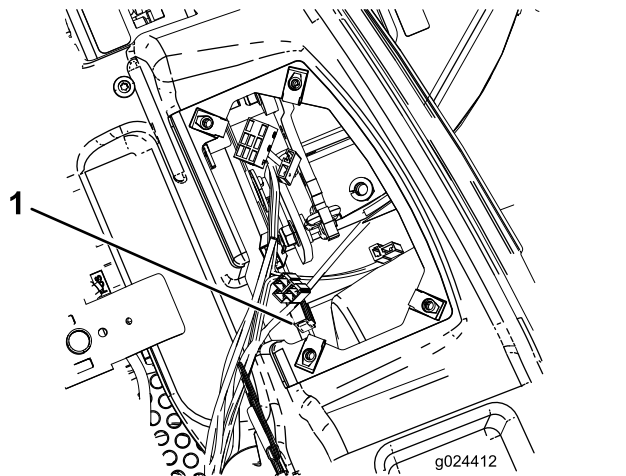

Figure 55

1. Engine fuse—25 A

3. Grasp the engine fuse and pull it straight and away from the fuse block (Figure 55).
4. Align a new fuse with the slot in the fuse block (Figure 54).
5. Push the fuse into the fuse block until the fuse is seated (Figure 54).

Hydraulic System Maintenance

Oil Type: Toro HYPR-OIL® 500 or 20W-50 motor oil.

System Capacity: 4.495 L (152 oz) with a filter change.

Important: Use oil specified or equivalent. Other fluids could cause system damage.

Checking the Hydraulic-Fluid Level

Service Interval: Every 25 hours

Check the expansion reservoir, and, if necessary, add fluid to the Full Cold line.

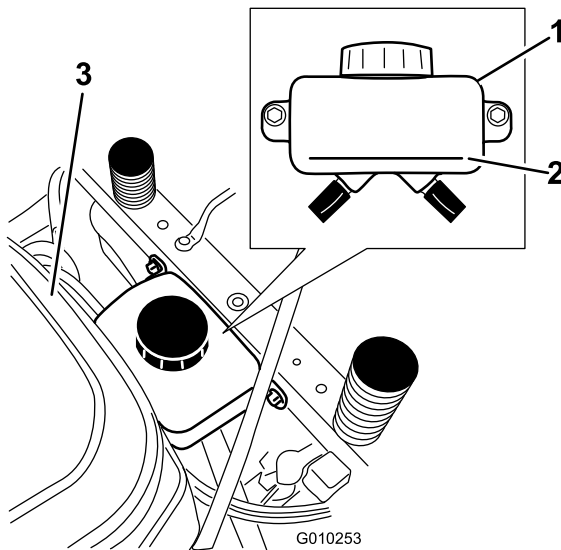

Figure 57

- 1. Expansion reservoir
- 2. Full Cold line
- 3. Engine

Changing the Hydraulic Filter and Fluid

The filter and fluid are changed at the same time. Once the new filter is installed and fluid is added, any air in the system must be purged.

The bleeding process is repeated until the fluid remains at the Full Cold line in the reservoir after purging. **Failure to properly perform this procedure can result in irreparable damage to the transaxle drive system.**

Removing the Hydraulic Filters

Important: When the hydraulic filter is removed, all of the hydraulic fluid in each transaxle will drain out. Use a container that holds 4.495 L (152 oz) or larger.

1. Shut off the engine, wait for all moving parts to stop, allow the engine to cool, remove the key, and engage the parking brake.
2. Locate the filter and guards on each transaxle drive system and remove the 3 screws securing the filter guard (Figure 58).

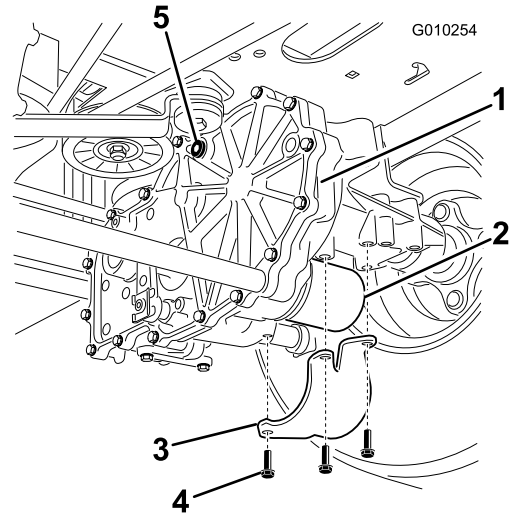

Figure 58
Right side shown

- 1. Transaxle drive
- 2. Hydraulic filter
- 3. Filter guard
- 4. Screws
- 5. Vent plug

3. Carefully clean the area around the filters.

Important: Do not allow dirt to enter the hydraulic system, as it may cause damage.

4. Place a container below the filter and drain the fluid.
5. Locate and remove the vent plug on each transmission.
6. Unscrew the filter and allow the fluid to drain from the drive system.
7. Repeat this procedure for both filters.

Installing the Hydraulic Filter

Service Interval: After the first 50 hours
Every 400 hours

1. Using the 3 screws to install the filter guards over each filter removed previously.
2. Verify that the vent plugs are removed before adding the fluid.

3. Slowly pour the specified fluid through the expansion reservoir until fluid comes out of a vent-plug hole.
4. Install the vent plug and torque it to 20 N•m (180 in-lb).
5. Continue to add fluid through the expansion reservoir until fluid comes out of the remaining vent-plug hole on the second transmission.
6. Install the second vent plug and torque it to 20 N•m (180 in-lb).
7. Continue to add fluid through the expansion reservoir until it reaches the Full Cold line on the expansion reservoir.

Important: Failure to perform the *Bleeding the Hydraulic System* procedure after changing hydraulic filters and oil can result in irreparable damage to the transaxle drive system.

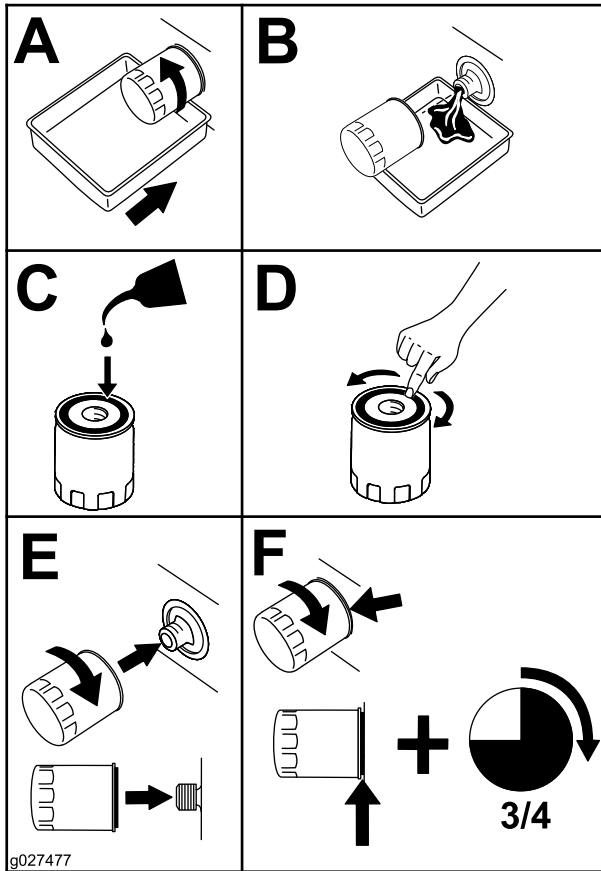

Figure 59

Bleeding the Hydraulic System

1. Raise the rear of machine up and support it with jack stands (or equivalent support) just high enough to allow the drive wheels to turn freely.

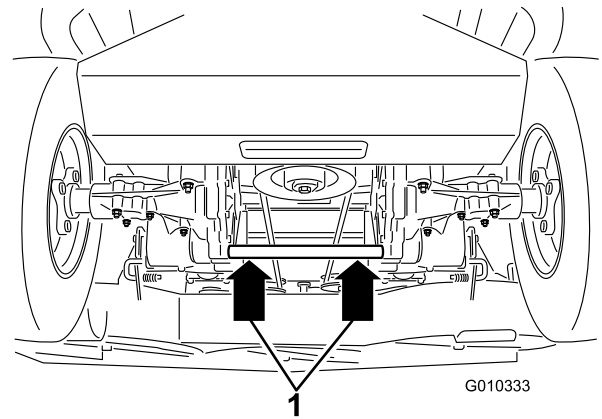

Figure 60

1. Jacking points

2. Enter the operator's position, start the engine, move the throttle control to 1/2 throttle position, and disengage the parking brake.
 - A. Move the bypass levers into the pushing the machine position; refer to [Pushing the Machine by Hand \(page 26\)](#). With the bypass valves open and the engine running, slowly move the motion-control levers in both forward and reverse directions (5 or 6 times).
 - B. Move the bypass levers into the operating the machine position. With the bypass valve closed and the engine running, slowly move the directional control in both forward and reverse directions (5 to 6 times).
 - C. Shut off the engine and check the fluid level in the expansion reservoir. Add the specified fluid as until it reaches the Full Cold line on the expansion reservoir.
3. Repeat step 2 until all of the air is completely purged from the system.

Note: When the transaxle operates at normal noise levels and moves smoothly forward and reverse at normal speeds, then the transaxle is considered purged.

Mower Deck Maintenance

Servicing the Cutting Blades

Maintain sharp blades throughout the cutting season, because sharp blades cut cleanly without tearing or shredding the grass blades. Tearing and shredding turns grass brown at the edges, which slows growth, and increases the chance of disease.

Check the cutter blades daily for sharpness, and for any wear or damage. File down any nicks and sharpen the blades as necessary. If a blade is damaged or worn, replace it immediately with a genuine Toro replacement blade. For convenient sharpening and replacement, you may want to keep extra blades on hand.

⚠ WARNING

A worn or damaged blade can break, and a piece of the blade could be thrown at you or bystanders, resulting in serious personal injury or death.

- Inspect the blade periodically for wear or damage.
- Replace a worn or damaged blade.

Before Inspecting or Servicing the Blades

Park the machine on a level surface, disengage the blade-control switch, move the motion-control levers outward to the PARK position, shut off the engine, and remove the key.

Inspecting the Blades

Service Interval: Before each use or daily

1. Inspect the cutting edges ([Figure 61](#)).

Note: If the edges are not sharp or have nicks, remove and sharpen the blades; refer to [Sharpening the Blades](#) (page 48).

2. Inspect the blades, especially the curved area ([Figure 61](#)).

Note: If you notice any damage, wear, or a slot forming in this area (items 3 and 4 in [Figure 61](#)), immediately install a new blade.

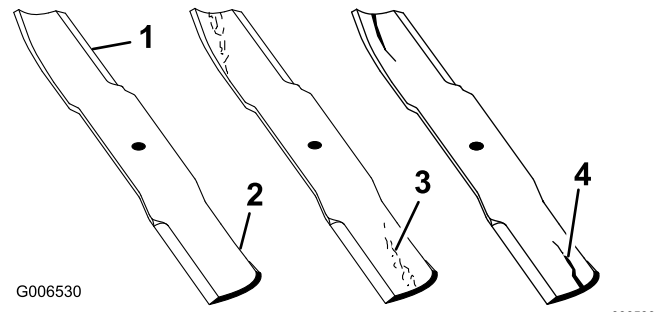

Figure 61

1. Cutting edge
2. Curved area
3. Wear/slot forming
4. Damage

Checking for Bent Blades

Note: The machine must be on a level surface for the following procedure.

1. Raise the mower deck to the highest height-of-cut position.
2. While wearing thickly-padded gloves, or other adequate hand protection, slowly rotate the blade to be measure into a position that allows effective measurement of the distance between the cutting edge and the level surface the machine is on ([Figure 62](#)).

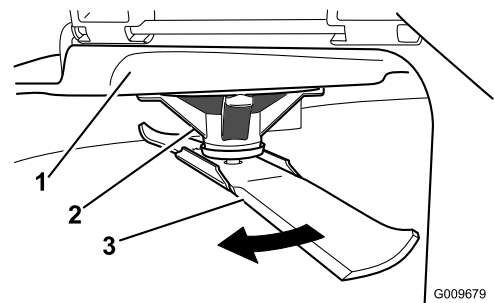

Figure 62

1. Deck
2. Spindle housing
3. Blade

3. Measure from the tip of the blade to the flat surface (Figure 63).

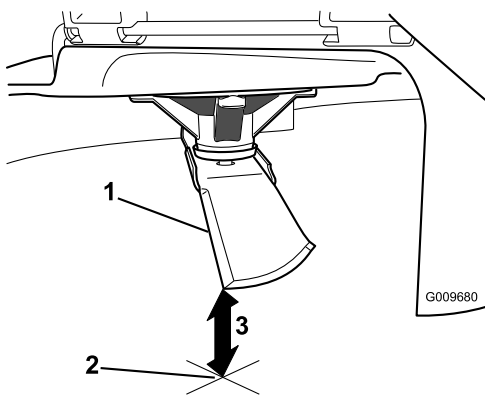

Figure 63

1. Blade (in position for measuring)
2. Level surface
3. Measured distance between blade and the surface (A)

4. Rotate the same blade 180 degrees so that the opposing cutting edge is now in the same position (Figure 64).

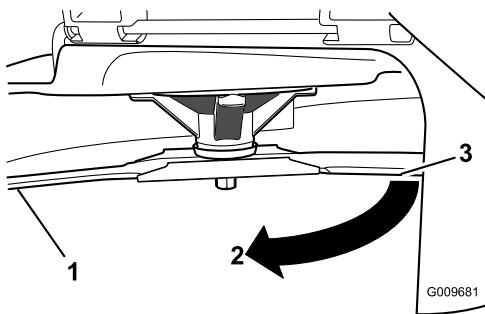

Figure 64

1. Blade (side previously measured)
2. Measurement (position used previously)
3. Opposing side of blade being moved into measurement position

5. Measure from the tip of the blade to the flat surface (Figure 65).

Note: The variance should be no more than 3 mm (1/8 inch).

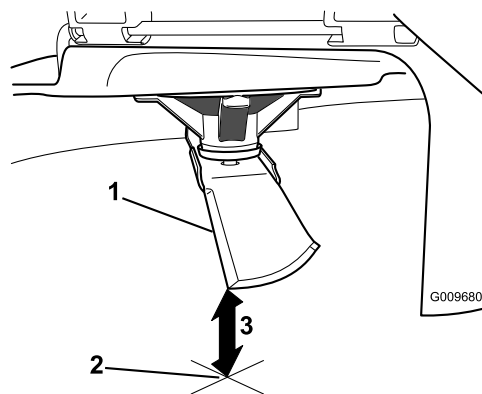

Figure 65

1. Opposite blade edge (in position for measuring)
2. Level surface
3. Second measured distance between blade and surface (B)

- A. If the difference between A and B is greater than 3 mm (1/8 inch), replace the blade with a new blade; refer to [Removing the Blades \(page 47\)](#) and [Installing the Blades \(page 48\)](#).

Note: If a bent blade is replaced with a new blade, and the dimension obtained continues to exceed 3mm (1/8 inch), the blade spindle could be bent. Contact an Authorized Toro Dealer for service.

- B. If the variance is within constraints, move to the next blade.

Repeat this procedure on each blade.

Removing the Blades

The blades must be replaced if a solid object is hit, if the blade is out of balance, or if the blade is bent. To ensure optimum performance and continued safety conformance of the machine, use genuine Toro replacement blades. Replacement blades made by other manufacturers may result in non-conformance with safety standards.

1. Hold the blade end using a rag or thickly-padded glove.
2. Remove the blade bolt, curved washer, and blade from the spindle shaft (Figure 66).

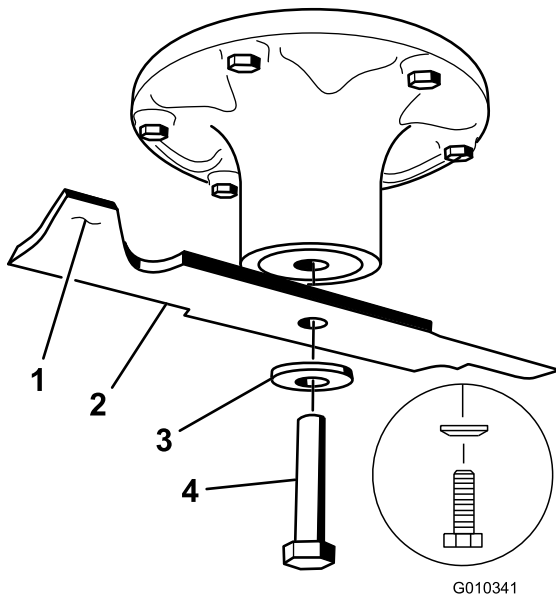

Figure 66

- | | |
|-----------------------|------------------|
| 1. Sail Area of Blade | 3. Curved washer |
| 2. Blade | 4. Blade bolt |

Sharpening the Blades

1. Use a file to sharpen the cutting edge at both ends of the blade (Figure 67).

Note: Maintain the original angle.

Note: The blade retains its balance if the same amount of material is removed from both cutting edges.

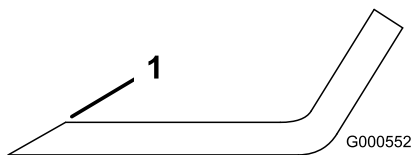

Figure 67

1. Sharpen at original angle.

2. Check the balance of the blade by putting it on a blade balancer (Figure 68).

Note: If the blade stays in a horizontal position, the blade is balanced, and can be used.

Note: If the blade is not balanced, file some metal off the end of the sail area only (Figure 67).

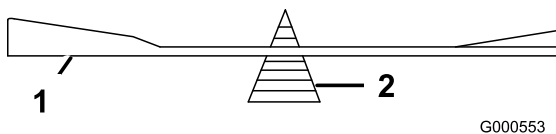

Figure 68

- | | |
|----------|-------------|
| 1. Blade | 2. Balancer |
|----------|-------------|

3. Repeat this procedure until the blade is balanced.

Installing the Blades

1. Install the blade onto the spindle shaft (Figure 66).

Important: The curved part of the blade must be pointing upward toward the inside of the mower to ensure proper cutting.

2. Install the spring disk and blade bolt with the spring disk cone installed toward the bolt head (Figure 66).
3. Torque the blade bolt to 135 to 150 N•m (100 to 110 ft-lb).

Leveling the Mower Deck

Ensure that the mower deck is level any time you install the mower deck or when you see an uneven cut on your lawn.

Check the mower deck for bent blades prior to leveling; remove and replace any bent blades; refer to [Checking for Bent Blades \(page 46\)](#) before continuing.

Level the mower deck side-to-side before adjusting the front-to-rear slope.

Requirements:

- The machine must be on a level surface.
- All 4 tires must be properly inflated; refer to [Checking the Tire Pressure \(page 43\)](#).

Checking the Side-to-Side Level

The mower blades must be level from side to side. Check the side-to-side level any time you install the mower or when you see an uneven cut on your lawn.

1. Park the machine on a level surface and disengage the blade-control switch.
2. Move the motion-control levers outward to the NEUTRAL-LOCK position, shut off the engine, remove the key, set the parking brake, and wait for all moving parts to stop before leaving the operating position.
3. Carefully rotate the blades side to side.
4. Measure between the outside cutting edges and the flat surface (Figure 69).

Note: If both measurements are not within 5 mm (3/16 inch), an adjustment is required; refer to [Leveling the Mower Deck \(page 49\)](#).

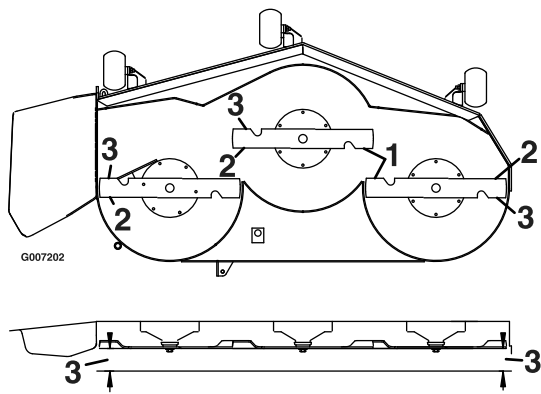

Figure 69

1. Blades side to side
2. Outside cutting edges
3. Measure from the tip of the blade to the flat surface here.

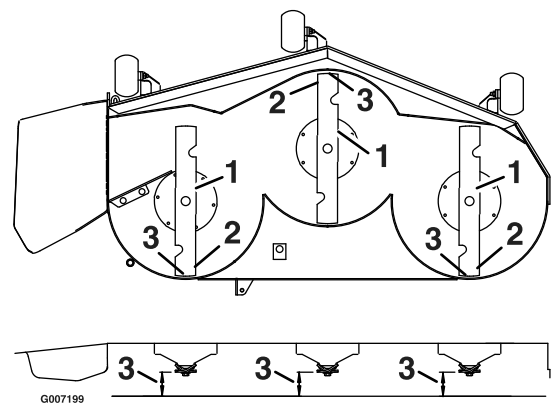

Figure 70

1. Blades front to rear
2. Outside cutting edges
3. Measure from the tip of the blade to the flat surface here.

Checking the Front-to-Rear Blade Slope

Check the front-to-rear blade level any time you install the mower. If the front of the mower is more than 7.9 mm (5/16 inch) lower than the rear of the mower, adjust the blade level using the following instructions:

1. Park the machine on a level surface and disengage the blade-control switch.
2. Move the motion-control levers outward to the NEUTRAL-LOCK position, engage the parking brake, shut off the engine, remove the key, and wait for all moving parts to stop before leaving the operating position.
3. Carefully rotate the blades so they are facing front to rear ([Figure 70](#)).
4. Measure from the tip of the front blade to the flat surface and the tip of the rear blade to the flat surface ([Figure 70](#)).

Note: If the front blade tip is not 1.6 to 7.9 mm (1/16 to 5/16 inch) lower than the rear blade tip, continue to the [Leveling the Mower Deck](#) (page 49) procedure.

Leveling the Mower Deck

1. Set anti-scalp rollers to top holes or remove them completely for this procedure; refer to [Adjusting the Anti-Scalp Rollers](#) (page 25).
2. Set the height-of-cut lever to the 76 mm (3 inch) position; refer to [Adjusting the Height of Cut](#) (page 24).
3. Place 2 6.6 cm (2-5/8 inches) blocks under each side of the front edge of the deck, but not under the anti-scalp roller brackets ([Figure 71](#)).
4. Place 2 7.3 cm (2-7/8 inches) thick blocks under the rear edge of the cutting deck skirt; one on each side of the cutting deck ([Figure 71](#)).

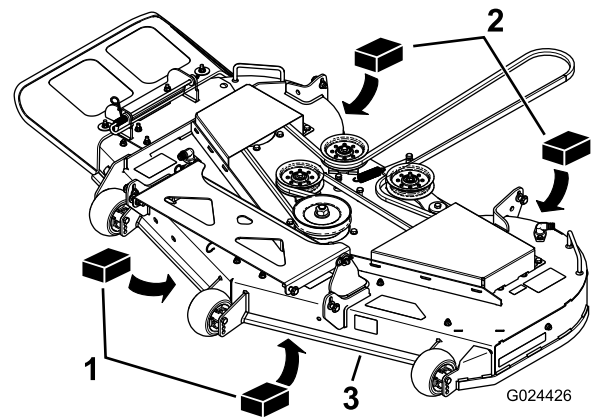

Figure 71

1. Wood block—6.6 cm (2-5/8 inches) thick
2. Wood block—7.3 cm (2-7/8 inches) thick
3. Front edge

5. Loosen the adjustment bolts on all 4 corners so that the deck is sitting securely on all 4 blocks ([Figure 72](#)).

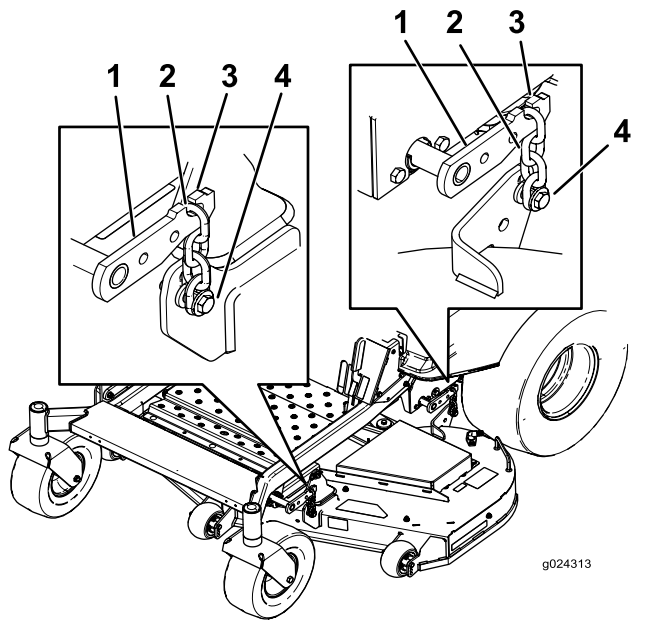

Figure 72

- | | |
|------------------|--------------------|
| 1. Deck-lift arm | 3. Hook |
| 2. Chain | 4. Adjustment bolt |
-
6. Ensure that there is tension on all 4 chains ([Figure 72](#)).
 7. Tighten the 4 adjustment bolts ([Figure 72](#)).
 8. Ensure that the blocks fit snugly under the deck skirt and that all bolts are tight.
 9. Verify that the deck is level by checking the side-to-side level and front-to-rear blade slope; repeat the deck leveling procedure if necessary.

Inspecting the Belts

Service Interval: Every 50 hours

Check the belts for squealing when the belt is rotating, blades slipping when cutting grass, frayed belt edges, burn marks and cracks are signs of a worn mower belt. Replace the mower belt if any of these conditions are evident.

Replacing the Mower Belt

Squealing when the belt is rotating, blades slipping when cutting grass, frayed belt edges, burn marks, and cracks are signs of a worn mower belt. Replace the mower belt if any of these conditions are evident.

1. Disengage the blade-control switch (PTO), move the motion-control levers to the NEUTRAL-LOCK position, and set the parking brake.
2. Shut off the engine, remove the key, and wait for all moving parts to stop before leaving the operating position.
3. Lower the mower to the 76 mm (3 inch) height-of-cut position.
4. Loosen the 2 bottom bolts holding the mower-deck curtain to the mower deck; refer to [Releasing the Mower-Deck Curtain \(page 35\)](#).
5. For each of the belt covers, loosen the 2 bolts, **but do not remove them**.
6. Slide the cover until it is clear of the bolts and lift it up and out to remove it.
7. Remove the floor pan to access the idler pulley.
8. Using a spring removal tool, (Toro Part No. 92-5771), remove the idler spring from the deck post to remove tension on the idler pulley ([Figure 73](#)).

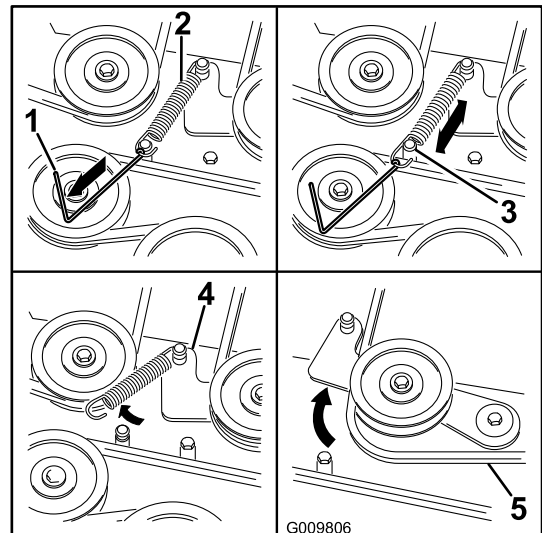

Figure 73

- | | |
|--|---------------|
| 1. Spring-removal tool (Toro Part No. 92-5771) | 4. Idler arm |
| 2. Idler spring | 5. Mower belt |
| 3. Deck post | |

9. Lower the mower to the lowest height of cut and place the height-of-cut pin in the lock position for the lowest height-of-cut.
10. Remove the belt from the mower-deck pulleys and remove the existing belt.

11. Install the new belt around the mower pulleys and the clutch pulley under the engine (Figure 73).

⚠ WARNING

The spring is under tension when installed and can cause personal injury.

Be careful when removing the belt.

12. Using a spring-removal tool, (Toro Part No. 92-5771), install the idler spring over the deck post and placing tension on the idler pulley and mower belt (Figure 73).
13. Ensure that the belt is properly seated in all pulleys.
14. To install the belt covers, insert the tabs on the each cover into the corresponding slots on the deck bracket, ensuring that they seat.
15. Rotate the cover to the deck and slide the notches under the loosened bolts until they are seated.
16. Tighten the bolts to secure the cover to the deck.
17. Tighten the 2 bottom bolts holding the mower-deck curtain to the mower deck; refer to [Releasing the Mower-Deck Curtain \(page 35\)](#).

Removing the Mower

Park the machine on a level surface and disengage the blade-control switch. Move the motion-control levers outward to the NEUTRAL-LOCK position, engage the parking brake, shut off the engine, remove the key, and wait for all moving parts to stop before leaving the operating position.

Lower the mower to the lowest height of cut. Select one of the following procedures depending on the mower deck size installed to complete the removal.

Preparing to Remove the Mower Deck

1. Lower the mower to the 76 mm (3 inch) height-of-cut position.
2. Loosen the 2 bottom bolts holding the mower-deck curtain to the mower deck; refer to [Releasing the Mower-Deck Curtain \(page 35\)](#).
3. Remove the mower belt from the engine pulley; refer to [Replacing the Mower Belt \(page 50\)](#).

Removing the Mower Deck

1. Remove the hairpin cotter and washer securing the link pin to the frame and deck, and remove the link bar (Figure 74).

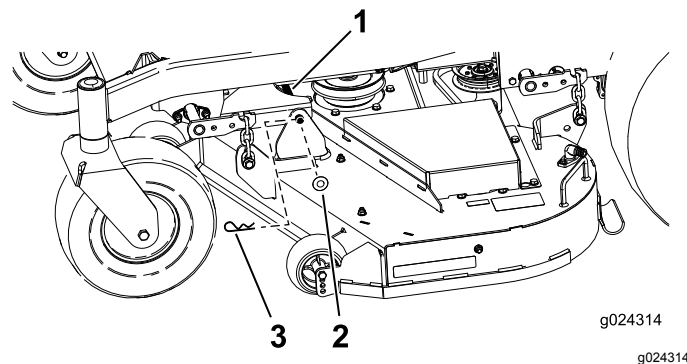

Figure 74

- | | |
|-------------|-------------------|
| 1. Link pin | 3. Hairpin cotter |
| 2. Washer | |

2. Lift up the mower deck to relieve tension from the mower deck.
3. Remove the chains from the hooks on the deck-lift arms (Figure 75).

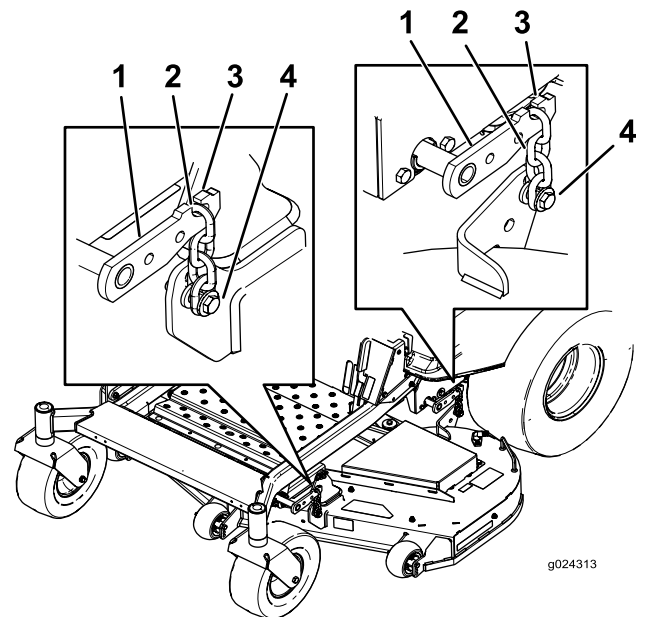

Figure 75

- | | |
|------------------|--------------------|
| 1. Deck-lift arm | 3. Hook |
| 2. Chain | 4. Adjustment bolt |

4. Raise the height of cut to the transport position.
5. Remove the belt from the clutch pulley on the engine.
6. Slide the mower out from underneath the machine.

Note: Retain all parts for future installation.

Installing the Mower Deck

1. Park the machine on a level surface and disengage the blade-control switch.
2. Move the motion-control levers outward to the NEUTRAL-LOCK position, shut off the engine, remove the key, set the parking brake, and wait for all moving parts to stop before leaving the operating position.
3. Slide the mower under the machine.
4. Lower the height-of-cut lever to the lowest position.
5. Place the height-of-cut pin in the lock position for lowest height of cut.
6. Lift the rear of the mower deck and attach the chains to the rear lift arms (Figure 75).
7. Attach the front chains to the front lift arms (Figure 75).
8. Install the long link bar through the frame hanger and deck.
9. Secure the link pin with the hairpin cotters and washers removed previously (Figure 74).
10. Install the mower belt onto the engine pulley; refer to Replacing the Mower Belt (page 50).
11. Tighten the 2 bottom bolts holding the mower-deck curtain to the mower deck; refer to Releasing the Mower-Deck Curtain (page 35).

Replacing the Grass Deflector

Service Interval: Before each use or daily—Inspect the grass deflector for damage.

▲ WARNING

An uncovered discharge opening could allow the lawn mower to throw objects in the operator's or bystander's direction and result in serious injury. Also, contact with the blade could occur.

Never operate the lawn mower unless you install a mulch plate, discharge deflector, or grass collection system.

Inspect the grass deflector for damage before each use. Replace any damaged parts before use.

1. Remove the cotter pin from the end of the rod (Figure 76).
2. Disengage the spring from the notch in the deflector bracket and slide the rod out of the

welded deck brackets, spring, and discharge deflector (Figure 76).

Note: Remove the damaged or worn discharge deflector.

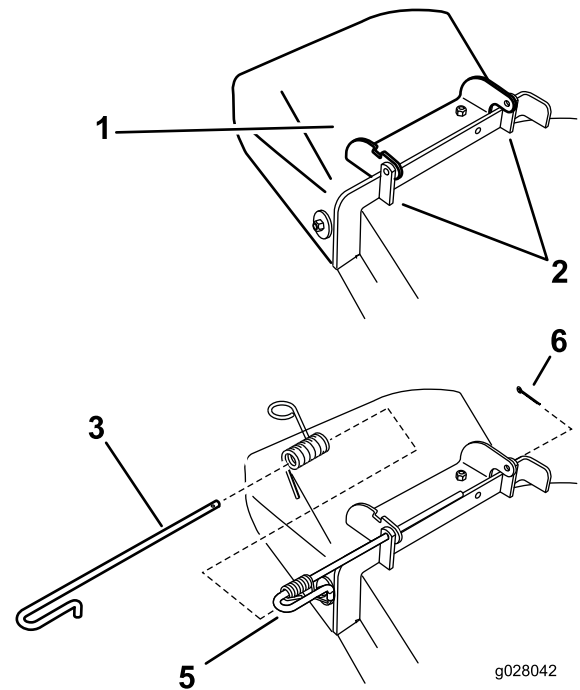

Figure 76

- | | |
|------------------|----------------------------------|
| 1. Deflector | 4. Spring |
| 2. Deck brackets | 5. Spring installed over the rod |
| 3. Rod | 6. Cotter pin |

3. Position the new discharge deflector with the bracket ends between the welded brackets on the deck (Figure 76).
4. Install the spring onto the straight end of the rod.

Note: Position the spring on the rod as shown in so the shorter spring end is coming from under the rod before the bend and going over the rod as it returns from the bend.

5. Lift the loop end of the spring and place it into the notch on the deflector bracket (Figure 77).

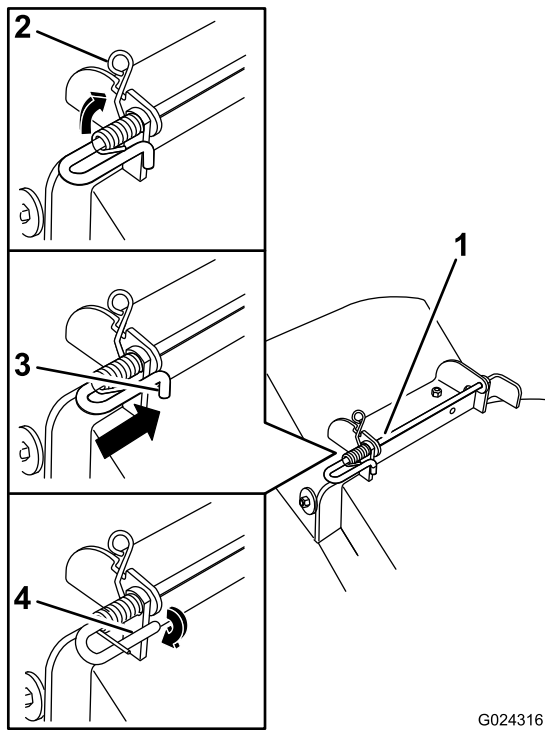

G024316

g024316

Figure 77

- | | |
|---|---|
| 1. Rod and spring assembly partially installed | 3. Rod, short end, moved behind the mower bracket |
| 2. Loop end of the spring installed into the notch in the deflector bracket | 4. Short end, retained by the mower bracket |

6. Secure the rod and spring assembly by twisting it so the short end of the rod can be placed behind the front bracket welded to the deck (Figure 77).

Important: The grass deflector must be spring loaded in the down position. Lift the deflector up to test that it snaps to the full down position.

7. Install the cotter pin into the end of the rod (Figure 76).

Cleaning

Washing the Underside of the Mower

Service Interval: After each use—Clean the mower housing.

Wash the underside of the mower after each use to prevent grass buildup for improved mulch action and clipping dispersal.

1. Park the machine on a level surface and disengage the blade-control switch.
2. Move the motion-control levers outward to the NEUTRAL-LOCK position, shut off the engine, remove the key, and wait for all moving parts to stop before leaving the operating position.
3. Attach the hose coupling to the end of the mower washout fitting, and turn the water on high (Figure 78).

Note: Spread petroleum jelly on the washout fitting O-ring to make the coupling slide on easier and protect the O-ring.

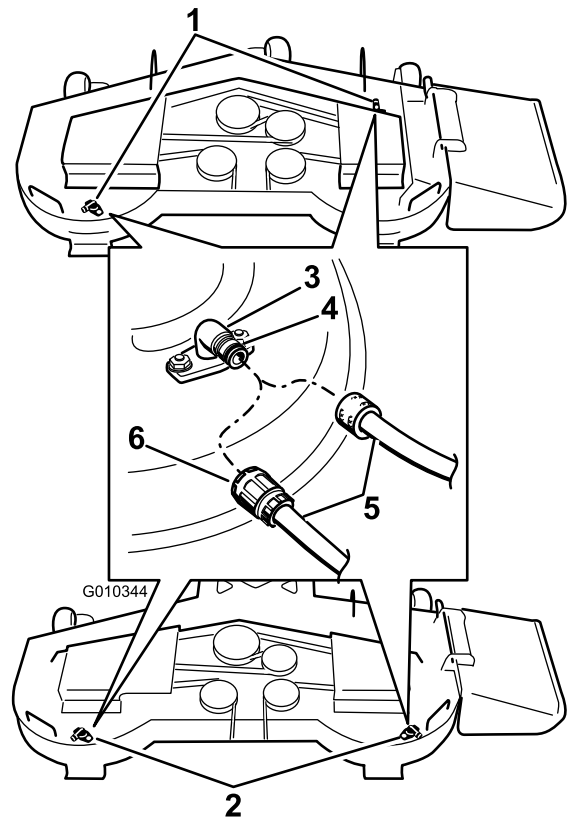

G010344

g010344

Figure 78

- | | |
|---|-------------|
| 1. Washout fitting locations on 54-inch decks | 4. O-ring |
| 2. Washout fitting locations on 48-inch decks | 5. Hose |
| 3. Washout fitting | 6. Coupling |

4. Lower the mower to the lowest height of cut.
5. Sit on the seat, start the engine, engage the blade-control switch, and let the mower run for 1 to 3 minutes.
6. Disengage the blade-control switch, shut off the engine, remove the ignition key, and wait for all moving parts to stop.
7. Turn the water off and remove the coupling from the washout fitting.

Note: If the mower is not clean after one washing, soak it and let it stand for 30 minutes. Then repeat the process.

8. Run the mower again for 1 to 3 minutes to remove excess water.

⚠ WARNING

A broken or missing washout fitting could expose you and others to thrown objects or blade contact. Contact with blade or thrown debris can cause injury or death.

- **Replace broken or missing washout fitting immediately, before using mower again.**
- **Never put your hands or feet under the mower or through openings in the mower.**

Disposing of Waste

Engine oil, batteries, hydraulic oil, and engine coolant are pollutants to the environment. Dispose of these according to your state and local regulations.

Storage

Cleaning and Storage

1. Disengage the blade-control switch (PTO), set the parking brake, turn the ignition key to the OFF position, and remove the key.
 2. Remove grass clippings, dirt, and grime from the external parts of the entire machine, especially the engine and hydraulic system. Clean dirt and chaff from the outside of the engine cylinder head fins and blower housing.
- Important:** You can wash the machine with mild detergent and water. Do not pressure wash the machine. Avoid excessive use of water, especially near the control panel, engine, hydraulic pumps, and motors.
3. Check the parking brake operation; refer to [Operating the Parking Brake \(page 20\)](#).
 4. Service the air cleaner; refer to [Servicing the Air Cleaner \(page 36\)](#).
 5. Grease the machine; refer to [Lubrication \(page 36\)](#).
 6. Change the crankcase oil; refer to [Changing the Engine Oil \(page 38\)](#).
 7. Check the tire pressure; refer to [Checking the Tire Pressure \(page 43\)](#).
 8. Change the hydraulic filter; refer to [Changing the Hydraulic Filter and Fluid \(page 44\)](#).
 9. Charge the battery; refer to [Charging the Battery \(page 42\)](#).
 10. Scrape any heavy buildup of grass and dirt from the underside of the mower, then wash the mower with a garden hose.

Note: Run the machine with the blade control switch (PTO) engaged and the engine at high idle for 2 to 5 minutes after washing.

11. Check the condition of the blades; refer to [Servicing the Cutting Blades \(page 46\)](#).
12. Prepare the machine for storage when non-use occurs over 30 days. Prepare the machine for storage as follows:
 - A. Add a petroleum based stabilizer/conditioner to fuel in the tank. Follow mixing instructions from the stabilizer manufacturer. Do not use an alcohol based stabilizer (ethanol or methanol).

Note: A fuel stabilizer/conditioner is most effective when mixed with fresh fuel and used at all times.

- B. Run the engine to distribute conditioned fuel through the fuel system (5 minutes).
- C. Shut off the engine, allow it to cool, and drain the fuel tank.
- D. Restart the engine and run it until it stops.
- E. Dispose of fuel properly. Recycle the fuel according to local codes.

***Important:* Do not store stabilizer/conditioned fuel over 90 days.**

- 13. Check and tighten all bolts, nuts, and screws. Repair or replace any part that is damaged.
- 14. Paint all scratched or bare metal surfaces. Paint is available from your Authorized Service Dealer.
- 15. Store the machine in a clean, dry garage or storage area. Remove the key from the ignition switch and keep it out of reach of children or other unauthorized users. Cover the machine to protect it and keep it clean.

Troubleshooting

Problem	Possible Cause	Corrective Action
The starter does not crank	<ol style="list-style-type: none"> 1. Blade-control switch (PTO) is engaged. 2. Parking brake is not on. 3. Drive levers are not in NEUTRAL-LOCK position. 4. Operator is not seated. 5. Battery is dead. 6. Electrical connections are corroded or loose. 7. Fuse is blown. 8. Relay or switch is defective. 	<ol style="list-style-type: none"> 1. Move the blade-control switch (PTO) to disengaged. 2. Set the parking brake. 3. Ensure that the drive levers are in the NEUTRAL-LOCK position. 4. Sit on the seat. 5. Charge the battery. 6. Check the electrical connections for good contact. 7. Replace fuse. 8. Contact an Authorized Service Dealer.
Engine does not start, starts hard, or fails to keep running	<ol style="list-style-type: none"> 1. Fuel tank is empty. 2. Fuel shutoff valve is closed. 3. Oil level in the crankcase is low. 4. The throttle and choke are not in the correct position. 5. Dirt in fuel filter. 6. Dirt, water, or stale fuel is in the fuel system. 7. Air cleaner is dirty. 8. Seat switch is not functioning properly. 9. Electrical connections are corroded, loose or faulty. 10. Relay or switch is defective. 11. Faulty spark plug. 12. Spark plug wire is not connected. 	<ol style="list-style-type: none"> 1. Fill the fuel tank. 2. Open the fuel shutoff valve. 3. Add oil to the crankcase. 4. Be sure the throttle control is midway between the SLOW and FAST positions, and the choke is in the ON position for a cold engine or the OFF position for a warm engine. 5. Replace the fuel filter. 6. Contact an Authorized Service Dealer. 7. Clean or replace the air cleaner element. 8. Check the seat switch indicator. Replace seat if needed. 9. Check the electrical connections for good contact. Clean connector terminals thoroughly with electrical contact cleaner, apply dielectric grease and reconnect. 10. Contact an Authorized Service Dealer. 11. Clean, adjust or replace spark plug. 12. Check the spark plug wire connection.
Engine loses power.	<ol style="list-style-type: none"> 1. Engine load is excessive. 2. Air cleaner is dirty. 3. Oil level in the crankcase is low. 4. Cooling fins and air passages above the engine are plugged. 5. Vent hole in the fuel cap is plugged. 6. Dirt in the fuel filter. 7. Dirt, water, or stale fuel is in the fuel system. 	<ol style="list-style-type: none"> 1. Reduce the ground speed. 2. Clean the air cleaner element. 3. Add oil to the crankcase. 4. Remove the obstruction from the cooling fins and air passages. 5. Clean or replace the fuel cap. 6. Replace the fuel filter. 7. Contact an Authorized Service Dealer.
Engine overheats.	<ol style="list-style-type: none"> 1. Engine load is excessive. 2. Oil level in the crankcase is low. 3. Cooling fins and air passages above the engine are plugged. 	<ol style="list-style-type: none"> 1. Reduce the ground speed. 2. Add oil to the crankcase. 3. Remove the obstruction from the cooling fins and air passages.
Mower pulls left or right (with levers fully forward)	<ol style="list-style-type: none"> 1. Tracking needs adjustment 2. Tire pressure in drive tires not correct. 	<ol style="list-style-type: none"> 1. Adjust the tracking. 2. Adjust tire pressure in the drive tires.

Problem	Possible Cause	Corrective Action
Machine does not drive.	<ol style="list-style-type: none"> 1. By pass valves is not closed tight. 2. Pump belt is worn, loose or broken. 3. Pump belt is off a pulley. 4. Broken or missing idler spring. 5. Hydraulic oil level is low or too hot. 	<ol style="list-style-type: none"> 1. Tighten the by pass valves. 2. Change the belt. 3. Change the belt. 4. Replace the spring. 5. Add hydraulic oil to reservoirs or let it cool down.
Abnormal vibration.	<ol style="list-style-type: none"> 1. Cutting blade(s) is/are bent or unbalanced. 2. Blade mounting bolt is loose. 3. Engine mounting bolts are loose. 4. Loose engine pulley, idler pulley, or blade pulley. 5. Engine pulley is damaged. 6. Blade spindle is bent. 7. Motor mount is loose or worn. 	<ol style="list-style-type: none"> 1. Install new cutting blade(s). 2. Tighten the blade mounting bolt. 3. Tighten the engine mounting bolts. 4. Tighten the appropriate pulley. 5. Contact an Authorized Service Dealer. 6. Contact an Authorized Service Dealer. 7. Contact an Authorized Service Dealer.
Uneven cutting height.	<ol style="list-style-type: none"> 1. Blade(s) not sharp. 2. Cutting blade(s) is/are bent. 3. Mower deck is not level. 4. Underside of mower is dirty. 5. Tire pressure is not correct. 6. Blade spindle bent. 	<ol style="list-style-type: none"> 1. Sharpen the blade(s). 2. Install new cutting blade(s). 3. Level mower deck from side-to-side and front-to-rear. 4. Clean the underside of the mower. 5. Adjust the tire pressure. 6. Contact an Authorized Service Dealer.
Blades do not rotate.	<ol style="list-style-type: none"> 1. Mower deck belt is worn, loose or broken. 2. Mower deck belt is off pulley. 3. Pump drive belt is worn, loose or broken. 4. Broken or missing idler spring. 	<ol style="list-style-type: none"> 1. Install new deck belt. 2. Install mower deck pulley and check the idler pulley, idler arm and spring for correct position and function. 3. Check the belt tension or install new belt. 4. Replace the spring.

Schematics

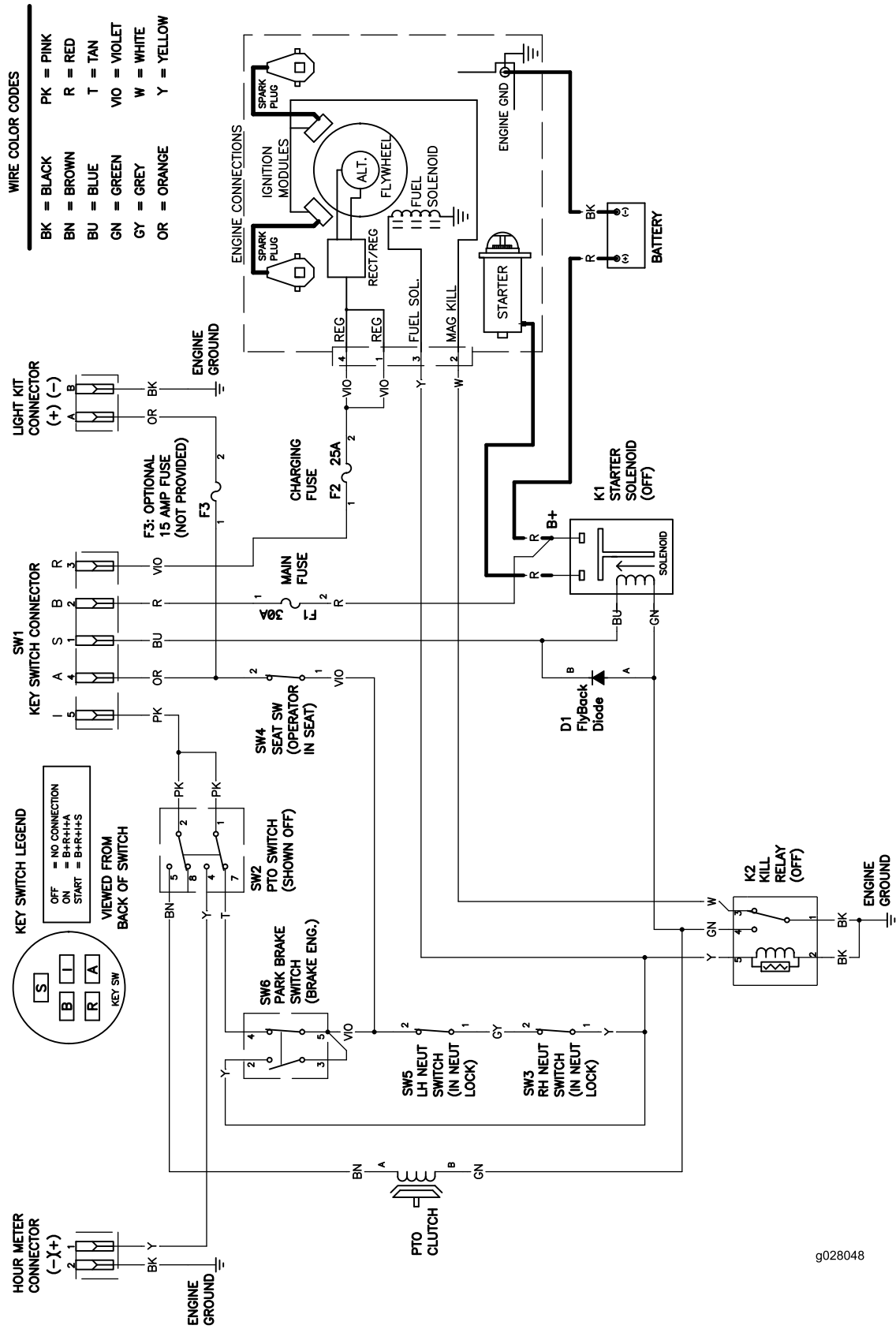

Wire Diagram (Rev. B)

g028048

g028048

International Distributor List

Distributor:	Country:	Phone Number:	Distributor:	Country:	Phone Number:
Agrolanc Kft	Hungary	36 27 539 640	Maquiver S.A.	Colombia	57 1 236 4079
Asian American Industrial (AAI)	Hong Kong	852 2497 7804	Maruyama Mfg. Co. Inc.	Japan	81 3 3252 2285
B-Ray Corporation	Korea	82 32 551 2076	Mountfield a.s.	Czech Republic	420 255 704 220
Brisa Goods LLC	Mexico	1 210 495 2417	Mountfield a.s.	Slovakia	420 255 704 220
Casco Sales Company	Puerto Rico	787 788 8383	Munditol S.A.	Argentina	54 11 4 821 9999
Ceres S.A.	Costa Rica	506 239 1138	Norma Garden	Russia	7 495 411 61 20
CSSC Turf Equipment (pvt) Ltd.	Sri Lanka	94 11 2746100	Oslinger Turf Equipment SA	Ecuador	593 4 239 6970
Cyril Johnston & Co.	Northern Ireland	44 2890 813 121	Oy Hako Ground and Garden Ab	Finland	358 987 00733
Cyril Johnston & Co.	Republic of Ireland	44 2890 813 121	Parkland Products Ltd.	New Zealand	64 3 34 93760
Fat Dragon	China	886 10 80841322	Perfetto	Poland	48 61 8 208 416
Femco S.A.	Guatemala	502 442 3277	Pratoverde SRL.	Italy	39 049 9128 128
FIVEMANS New-Tech Co., Ltd	China	86-10-6381 6136	Prochaska & Cie	Austria	43 1 278 5100
ForGarder OU	Estonia	372 384 6060	RT Cohen 2004 Ltd.	Israel	972 986 17979
G.Y.K. Company Ltd.	Japan	81 726 325 861	Riversa	Spain	34 9 52 83 7500
Geomechaniki of Athens	Greece	30 10 935 0054	Lely Turfcare	Denmark	45 66 109 200
Golf international Turizm	Turkey	90 216 336 5993	Lely (U.K.) Limited	United Kingdom	44 1480 226 800
Hako Ground and Garden	Sweden	46 35 10 0000	Solvart S.A.S.	France	33 1 30 81 77 00
Hako Ground and Garden	Norway	47 22 90 7760	Spypros Stavrinides Limited	Cyprus	357 22 434131
Hayter Limited (U.K.)	United Kingdom	44 1279 723 444	Surge Systems India Limited	India	91 1 292299901
Hydroturf Int. Co Dubai	United Arab Emirates	97 14 347 9479	T-Markt Logistics Ltd.	Hungary	36 26 525 500
Hydroturf Egypt LLC	Egypt	202 519 4308	Toro Australia	Australia	61 3 9580 7355
Irrimac	Portugal	351 21 238 8260	Toro Europe NV	Belgium	32 14 562 960
Irrigation Products Int'l Pvt Ltd.	India	0091 44 2449 4387	Valtech	Morocco	212 5 3766 3636
Jean Heybroek b.v.	Netherlands	31 30 639 4611	Victus Emak	Poland	48 61 823 8369

European Privacy Notice

The Information Toro Collects

Toro Warranty Company (Toro) respects your privacy. In order to process your warranty claim and contact you in the event of a product recall, we ask you to share certain personal information with us, either directly or through your local Toro company or dealer.

The Toro warranty system is hosted on servers located within the United States where privacy law may not provide the same protection as applies in your country.

BY SHARING YOUR PERSONAL INFORMATION WITH US, YOU ARE CONSENTING TO THE PROCESSING OF YOUR PERSONAL INFORMATION AS DESCRIBED IN THIS PRIVACY NOTICE.

The Way Toro Uses Information

Toro may use your personal information to process warranty claims, to contact you in the event of a product recall and for any other purpose which we tell you about. Toro may share your information with Toro's affiliates, dealers or other business partners in connection with any of these activities. We will not sell your personal information to any other company. We reserve the right to disclose personal information in order to comply with applicable laws and with requests by the appropriate authorities, to operate our systems properly or for our own protection or that of other users.

Retention of your Personal Information

We will keep your personal information as long as we need it for the purposes for which it was originally collected or for other legitimate purposes (such as regulatory compliance), or as required by applicable law.

Toro's Commitment to Security of Your Personal Information

We take reasonable precautions in order to protect the security of your personal information. We also take steps to maintain the accuracy and current status of personal information.

Access and Correction of your Personal Information

If you would like to review or correct your personal information, please contact us by email at legal@toro.com.

Australian Consumer Law

Australian customers will find details relating to the Australian Consumer Law either inside the box or at your local Toro Dealer.



The Toro Warranty

Limited Warranty (see warranty periods below)

Conditions and Products Covered

The Toro Company and its affiliate, Toro Warranty Company, pursuant to an agreement between them, jointly promise to repair the Toro Products listed below if defective in materials or workmanship.

The following time periods apply from the date of purchase by the original owner:

Products	Warranty Period
TimeCutter and MX Mowers • Engines ¹ — Residential use	Residential use ² – 3 years Kawasaki – 3 years Kohler – 3 years Toro – 3 years
TimeCutter and MX Mowers • Engines ¹ — Commercial use	Commercial use 30 days Kawasaki – 3 years Kohler – 90 days Toro – 90 days
TITAN SW and ZS Series Mowers – Residential or Commercial use • Engines ¹ — Residential or Commercial use • Frame	3 years or 300 hours ³ Kawasaki – 3 years Lifetime (original owner only) ⁴
TITAN MX Series Mowers – Residential or Commercial use • Engines ¹ — Residential or Commercial use • Frame	4 years or 400 hours ³ Kawasaki – 3 years Lifetime (original owner only) ⁴
All Mowers • Attachments • Battery	1 year 90 days Parts and Labor 1 year Parts only
• Belts and Tires	90 days

¹Some engines used on Toro Products are warranted by the engine manufacturer.

²Residential use means use of the product on the same lot as your home. Use at more than one location is considered commercial use and the commercial use warranty would apply.

³Whichever occurs first.

⁴Lifetime Frame Warranty - If the main frame, consisting of the parts welded together to form the tractor structure that other components such as the engine are secured to, cracks or breaks in normal use, it will be repaired or replaced, at Toro's option, under warranty at no cost for parts and labor. Frame failure due to misuse or abuse and failure or repair required due to rust or corrosion are not covered.

Warranty may be denied if the hour meter is disconnected, altered, or shows signs of being tampered with.

Owner Responsibilities

You must maintain your Toro Product by following the maintenance procedures described in the *Operator's Manual*. Such routine maintenance, whether performed by a dealer or by you, is at your expense.

Instructions for Obtaining Warranty Service

If you think that your Toro Product contains a defect in materials or workmanship, follow this procedure:

1. Contact any Authorized Toro Service Dealer to arrange service at their dealership. To locate a dealer convenient to you, access our web site at www.Toro.com. You may also call the numbers listed in item #3 to use the 24-hour Toro Dealer locator system.
2. Bring the product and your proof of purchase (sales receipt) to the Service Dealer. The dealer will diagnose the problem and determine if it is covered under warranty.
3. If for any reason you are dissatisfied with the Service Dealer's analysis or with the assistance provided, contact us at:

Toro Warranty Company
Customer Care Department, RLC Division
8111 Lyndale Avenue South
Bloomington, MN 55420-1196
Toll free at 866-216-6029 (U.S. customers)
Toll free at 866-216-6030 (Canadian customers)

Items and Conditions Not Covered

There is no other express warranty except for special emission system coverage and engine warranty coverage on some products. This express warranty does not cover the following:

- Cost of regular maintenance service or parts, such as filters, fuel, lubricants, oil changes, spark plugs, air filters blade sharpening or worn blades, cable/linkage adjustments, or brake and clutch adjustments
- Components failing due to normal wear
- Any product or part which has been altered or misused or neglected or requires replacement or repair due to accidents or lack of proper maintenance
- Pickup and delivery charges
- Repairs or attempted repairs by anyone other than an Authorized Toro Service Dealer
- Repairs necessary due to failure to follow recommended fuel procedure (consult *Operator's Manual* for more details)
 - Removing contaminants from the fuel system is not covered
 - Use of old fuel (more than one month old) or fuel which contains more than 10% ethanol or more than 15% MTBE
 - Failure to drain the fuel system prior to any period of non-use over one month

General Conditions

All repairs covered by these warranties must be performed by an Authorized Toro Service Dealer using Toro approved replacement parts.

Neither The Toro Company nor Toro Warranty Company is liable for indirect, incidental or consequential damages in connection with the use of the Toro Products covered by this warranty, including any cost or expense of providing substitute equipment or service during reasonable periods of malfunction or non-use pending completion of repairs under this warranty.

All implied warranties of merchantability (that the product is fit for ordinary use) and fitness for use (that the product is fit for a particular purpose) are limited to the duration of the express warranty.

Some states do not allow exclusions of incidental or consequential damages, or limitations on how long an implied warranty lasts, so the above exclusions and limitations may not apply to you.

This warranty gives you specific legal rights, and you may also have other rights which vary from state to state.

Countries Other than the United States or Canada

This warranty is not valid in Mexico. Customers who have purchased Toro products outside the United States or Canada should contact their Toro Distributor (Dealer) to obtain guarantee policies for your country, province, or state. If for any reason you are dissatisfied with your Distributor's service or have difficulty obtaining guarantee information, contact the Toro importer. If all other remedies fail, you may contact us at Toro Warranty Company.

Australian Consumer Law: Australian customers will find details relating to the Australian Consumer Law either inside the box or at your local Toro Dealer.