



Count on it.

Operator's Manual

**Z Master® Professional 5000
Series Riding Mower
with 60in TURBO FORCE® Side Discharge
Mower**

Model No. 74991—Serial No. 316000001 and Up

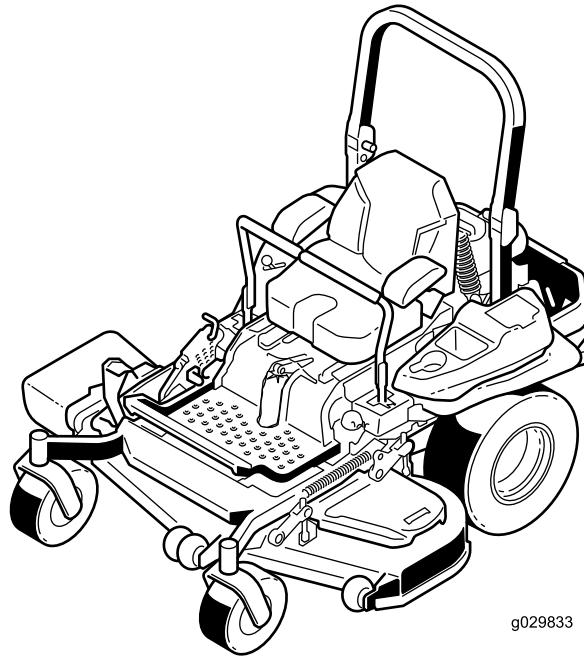

g029833



This spark ignition system complies with Canadian ICES-002

It is a violation of California Public Resource Code Section 4442 or 4443 to use or operate the engine on any forest-covered, brush-covered, or grass-covered land unless the engine is equipped with a spark arrester, as defined in Section 4442, maintained in effective working order or the engine is constructed, equipped, and maintained for the prevention of fire.

⚠ WARNING

Removing standard original equipment parts and accessories may alter the warranty, traction, and safety of the machine. Failure to use original Toro parts could cause serious injury or death. Making unauthorized changes to the engine, fuel or venting system, may violate EPA and CARB regulations.

Replace all parts including, but not limited to, tires, belts, blades, and fuel system components with original Toro parts.

The enclosed *Engine Owner's Manual* is supplied for information regarding the US Environmental Protection Agency (EPA) and the California Emission Control Regulation of emission systems, maintenance, and warranty. Replacements may be ordered through the engine manufacturer.

⚠ WARNING

CALIFORNIA
Proposition 65 Warning

The engine exhaust from this product contains chemicals known to the State of California to cause cancer, birth defects, or other reproductive harm.

Introduction

This rotary-blade, riding lawn mower is intended to be used by residential homeowners or professional, hired operators. It is designed primarily for cutting grass on well-maintained lawns on residential or commercial properties. It is not designed for cutting brush or for agricultural uses.

Read this information carefully to learn how to operate and maintain your product properly and to avoid injury and product damage. You are responsible for operating the product properly and safely.

You may contact Toro directly at www.Toro.com for product safety and operation training materials, accessory information, help finding a dealer, or to register your product.

Whenever you need service, genuine Toro parts, or additional information, contact an Authorized Service Dealer or Toro Customer Service and have the model and serial numbers of your product ready. **Figure 1** identifies the location of the model and serial numbers on the product. Write the numbers in the space provided.

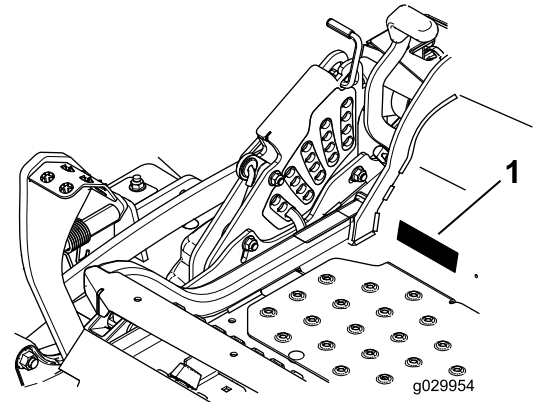

Figure 1

1. Model and serial number location

Model No. _____
Serial No. _____

This manual identifies potential hazards and has safety messages identified by the safety-alert symbol (**Figure 2**), which signals a hazard that may cause serious injury or death if you do not follow the recommended precautions.



Figure 2

1. Safety-alert symbol

This manual uses 2 words to highlight information. **Important** calls attention to special mechanical information and **Note** emphasizes general information worthy of special attention.

Contents

Safety	4	Servicing the High-Pressure Fuel Filter	46
Safe Operating Practices	4	Servicing the Fuel Tank	46
Toro Mower Safety	6	Electrical System Maintenance	47
Slope Indicator	7	Servicing the Battery	47
Safety and Instructional Decals	8	Servicing the Fuses	48
Product Overview	14	Jump-Starting the Machine	48
Controls	14	Drive System Maintenance	50
Specifications	16	Checking the Seat Belt	50
Operation	16	Checking the Rollover-Protection-System (ROPS) Knobs	50
Adding Fuel	16	Adjusting the Tracking	51
Checking the Engine-Oil Level	18	Checking the Tire Pressure	51
Breaking in a New Machine	18	Checking the Wheel Lug Nuts	51
Using the Rollover-Protection System (ROPS)	18	Checking the Wheel Hub Slotted Nut	52
Entering the Operating Position	19	Adjusting the Caster-Pivot Bearing	52
Think Safety First	19	Using the Clutch Shim	53
Operating the Parking Brake	20	Cooling System Maintenance	55
Operating the Mower Blade-Control Switch (PTO)	20	Cleaning the Engine Screen and Engine-Oil Cooler	55
Operating the Throttle	20	Cleaning the Engine Cooling Fins and Shrouds	55
Operating the Ignition Switch	21	Cleaning the Hydraulic Units	56
Using the Fuel-Shutoff Valve	21	Brake Maintenance	56
Starting and Shutting Off the Engine	21	Adjusting the Parking Brake	56
Using the Safety-Interlock System	23	Belt Maintenance	57
Driving Forward or Backward	24	Inspecting the Belts	57
Shutting Off the Machine	25	Replacing the Mower Belt	57
Adjusting the Height of Cut	25	Replacing the Hydraulic-Pump Drive Belt	58
Adjusting the Anti-Scalp Rollers	27	Controls System Maintenance	59
Adjusting the Flow-Baffle-Cam Locks	28	Adjusting the Control-Handle Position	59
Positioning the Flow Baffle	29	Adjusting the Motion-Control Linkage	60
Positioning the Seat	30	Adjusting the Motion-Control Damper	61
Unlatching the Seat	30	Adjusting the Motion-Control Neutral-Lock Pivot	62
Adjusting the MyRide™ Suspension System	30	Hydraulic System Maintenance	62
Using the Drive-Wheel Release Valves	31	Servicing the Hydraulic System	62
Using the Side Discharge	32	Mower Deck Maintenance	64
Transporting the Machine	33	Leveling the Mower Deck	64
Loading the Machine	33	Servicing the Cutting Blades	66
Operating Tips	35	Removing the Mower Deck	69
Maintenance	36	Replacing the Grass Deflector	70
Recommended Maintenance Schedule(s)	36	Cleaning	71
Lubrication	37	Cleaning under the Mower	71
Adding Light Oil or Spray Lubrication	37	Cleaning the Suspension System	71
Greasing the Mower	38	Disposing of Waste	71
Lubricating the Caster-Wheel Hubs	39	Storage	71
Engine Maintenance	40	Cleaning and Storage	71
Servicing the Air Cleaner	40	Troubleshooting	73
Servicing the Engine Oil	41	Schematics	76
Servicing the Spark Plug	44		
Checking the Spark Arrester (if Equipped)	45		
Fuel System Maintenance	46		
Servicing the Electronic Fuel-Injection System	46		
Replacing the Low-Pressure Fuel Filter	46		

Safety

Improper use or maintenance by the operator or owner can result in injury. To reduce the potential for injury, comply with these safety instructions, and pay attention to the safety alert symbol, which means Caution, Warning, or Danger—personal safety instruction. Failure to comply with the instructions may result in personal injury or death.

This machine was manufactured according to the appropriate regulatory standards in effect at the time of manufacture. Modifying this machine in any way may cause it to be out of compliance with those standards and with the instructions in this *Operator's Manual*. Modifications to this machine should only be made by either the manufacturer or an Authorized Toro Dealer.

This product is capable of amputating hands and feet. Follow all safety instructions to avoid serious injury or death.

The owner/user can prevent and is responsible for accidents or injuries occurring to people, or damage to property.

The addition of attachments made by other manufacturers that do not meet American National Standards Institute certification will cause noncompliance of this machine.

Safe Operating Practices

The following instructions are adapted from ANSI standard B71.4-2012.

Training

- Read the *Operator's Manual* and other training material.
- If the operator(s) or mechanic(s) cannot read the manual language, it is the owner's responsibility to explain this material to them.
- Become familiar with the safe operation of the equipment, operator controls, and safety signs.
- All operators and mechanics should be trained. The owner is responsible for training the users.
- Never let children or untrained people operate or service the equipment. Local regulations may restrict the age of the operator.
- The owner/user can prevent and is responsible for accidents or injuries occurring to people, or damage to property.

Preparation

- Evaluate the terrain to determine what accessories and attachments are needed to properly and safely perform the job. Only use accessories and attachments approved by the manufacturer.
- Wear appropriate clothing including: substantial slip-resistant footwear, safety glasses, and hearing protection. Tie back long hair and do not wear jewelry.
- Inspect the area where the equipment is used, and remove all objects that can be thrown by the machine.
- Check that operator's presence controls, safety switches, and shields are attached and functioning properly. Do not operate the machine unless they are functioning properly.

Operation

- Lightning can cause severe injury or death. If lightning is seen or thunder is heard in the area, do not operate the machine; seek shelter.
- Do not run an engine in an enclosed area.
- Operate only in well-lit areas, keeping away from holes and hidden hazards.
- Ensure that all drives are in neutral and that the parking brake is engaged before starting engine. Start the engine only from the operator's position.
- Make sure that you have good footing while using this machine, especially when backing up. Reduced footing could cause slipping.
- Slow down and use extra care on hillsides. Be sure to travel side to side on hillsides. Turf conditions can affect the stability of the machine. Use caution while operating near drop-offs.
- Slow down and use caution when making turns and when changing directions on slopes.
- Do not raise the mower deck with the blades running.
- Do not operate the machine without the PTO shield or other guards securely in place. Be sure that all interlocks are attached, adjusted properly, and functioning properly.
- Do not operate with the discharge deflector raised, removed or altered, unless you are using a grass catcher.
- Do not change the engine governor setting or overspeed the engine.
- Stop the machine on level ground, disengage drives, engage the parking brake (if provided), shut off the engine before leaving the operator's position for any reason, including emptying the catchers or unclogging the chute.
- Stop the machine and inspect the blades after striking objects or if an abnormal vibration occurs.

Make the necessary repairs before resuming operation.

- Keep your hands and feet away from the cutting unit.
- Look behind and down before backing up to ensure a clear path.
- Keep pets and bystanders away from an operating machine.
- Slow down and use caution when making turns and crossing roads and sidewalks. Stop the blades if you are not mowing.
- Be aware of the mower-discharge direction and do not point it at anyone.
- Do not operate the mower when tired, ill, or under the influence of alcohol or drugs.
- Use care when loading or unloading the machine into or from a trailer or truck.
- Use care when approaching blind corners, shrubs, trees, or other objects that may obscure vision.

Safe Handling of Fuels

- To avoid personal injury or property damage, use extreme care in handling gasoline. Gasoline is extremely flammable and the vapors are explosive.
- Extinguish all cigarettes, cigars, pipes, and other sources of ignition.
- Use only an approved fuel container.
- Do not remove the fuel cap or add fuel with the engine running.
- Allow the engine to cool before fueling.
- Do not fuel the machine indoors.
- Do not store the machine or fuel container where there is an open flame, spark, or pilot light, such as on a water heater or on other appliances.
- Do not fill containers inside a vehicle, on a truck, or on a trailer bed with a plastic liner. Always place containers on the ground away from your vehicle before filling.
- Remove equipment from the truck or trailer and fuel it on the ground. If this is not possible, then add fuel with such equipment as a portable container rather than from a fuel-dispenser nozzle.
- Keep the nozzle in contact with the rim of the fuel tank or container opening at all times until fueling is complete.
- Do not use a nozzle lock-open device.
- If you spill fuel on clothing, change your clothing immediately.
- Do not overfill the fuel tank. Replace the fuel cap and tighten it securely.

Maintenance and Storage

- Disengage drives, set the parking brake, shut off the engine, and remove the key or disconnect spark-plug wire. Wait for all movement to stop before adjusting, cleaning, or repairing the machine.
- Park the machine on a level surface.
- Clean grass and debris from the cutting unit, drives, mufflers, and engine to help prevent fires.
- Clean up oil or fuel spills.
- Let the engine cool before storing the machine.
- Do not store fuel near flames or drain fuel indoors.
- Do not allow untrained personnel to service the machine.
- Use jack stands to support components when required.
- Carefully release pressure from components with stored energy.
- Disconnect the battery or remove the spark-plug wire before making any repairs. Disconnect the negative terminal first and the positive terminal last. Connect the positive terminal first and negative last.
- Use care when checking the blades. Wrap the blade(s) or wear thickly padded gloves, and use caution when servicing them. Only replace blades; do not straighten or weld them.
- Keep hands and feet away from moving parts. If possible, do not make adjustments with the engine running.
- Keep all parts in good working condition and all hardware tightened. Replace all worn or damaged decals.

Hauling

- Use care when loading or unloading the machine into a trailer or a truck.
- Use a full-width ramp for loading machine into a trailer or a truck.
- Tie the machine down securely using straps, chains, cable, or ropes. Both front and rear straps should be directed down and outward from the machine.

Toro Mower Safety

The following list contains safety information specific to Toro products and other safety information that you must know.

This product is capable of amputating hands and feet, and of throwing objects. Always follow all safety instructions to avoid serious injury or death.

This product is designed for cutting and recycling grass, or, when equipped with a grass bagger, for catching cut grass. Any use for purposes other than these could prove dangerous to the user and bystanders.

Using the Rollover-Protection System (ROPS)

- The ROPS is an integral and effective safety device. Keep the ROPS in the raised and locked position and use the seat belt when operating the machine.
- Lower the ROPS temporarily only when absolutely necessary. Do not wear the seat belt when the ROPS is folded down.
- Be aware there is no rollover protection when the ROPS is in the down position.
- Be certain that the seat belt can be released quickly in the event of an emergency.
- Check the area to be mowed and never fold down the ROPS in areas where there are slopes, drop-offs, or water.
- Check carefully for overhead clearances (i.e. branches, doorways, electrical wires) before driving under any objects and do not contact them.
- Keep the ROPS in safe operating condition by periodically thoroughly inspecting for damage and keeping all mounting fasteners tight.
- Replace a damaged ROPS. Do not repair or revise.
- **Do not** remove the ROPS.
- Any alterations to a ROPS must be approved by the manufacturer.
- Do not mow slopes greater than 15 degrees.

Service

- Do not store the machine or a fuel container inside where there is an open flame, such as near a water heater or furnace.
- Keep the nuts and bolts tight, especially the blade-attachment bolts.
- Never interfere with the intended function of a safety device or reduce the protection provided by a safety device. Check their proper operation regularly.
- To best protect your investment and maintain optimal performance of your Toro equipment, count on Toro genuine parts. When it comes to reliability, Toro delivers replacement parts designed to the exact engineering specifications of our equipment. For peace of mind, insist on Toro genuine parts.
- Check brake operation frequently. Adjust and service as required.

Slope Indicator



G011841

g011841

Figure 3

This page may be copied for personal use.

1. The maximum slope you can safely operate the machine on is **15 degrees**. Use the slope chart to determine the degree of slope of hills before operating. **Do not operate this machine on a slope greater than 15 degrees.** Fold along the appropriate line to match the recommended slope.
2. Align this edge with a vertical surface, a tree, building, fence pole, etc.
3. Example of how to compare slope with folded edge

Safety and Instructional Decals



Safety decals and instructions are easily visible to the operator and are located near any area of potential danger. Replace any decal that is damaged or lost.



58-6520

decal58-6520

1. Grease

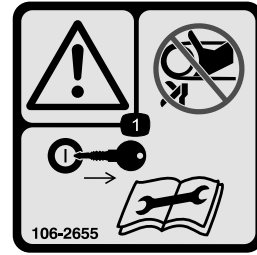

106-2655

decal106-2655

1. Warning—do not touch or approach moving belts; remove the ignition key and read the instructions before servicing or performing maintenance.

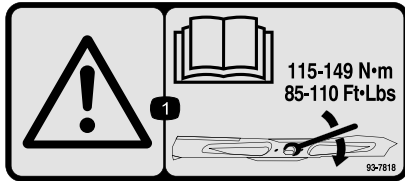

93-7818

decal93-7818

1. Warning—read the *Operator's Manual* for instructions on torquing the blade bolt/nut to 115 to 149 N·m (85 to 110 ft-lb).



106-5517

decal106-5517

1. Warning—do not touch the hot surface.

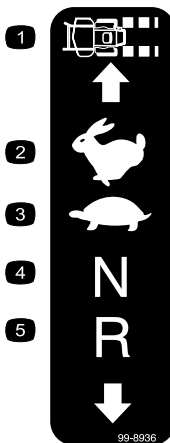

99-8936

decal99-8936

- | | |
|------------------|------------|
| 1. Machine speed | 4. Neutral |
| 2. Fast | 5. Reverse |
| 3. Slow | |



107-3069

decal107-3069

1. Warning—there is no rollover protection when the roll bar is down.
2. To avoid injury or death from a rollover accident, keep the roll bar in the fully raised and locked position and wear the seat belt. Lower the roll bar only when absolutely necessary; do not wear the the seat belt when the roll bar is down.
3. Read the *Operator's Manual*; drive slowly and carefully.

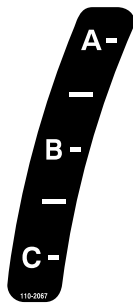

110-2067

decal110-2067

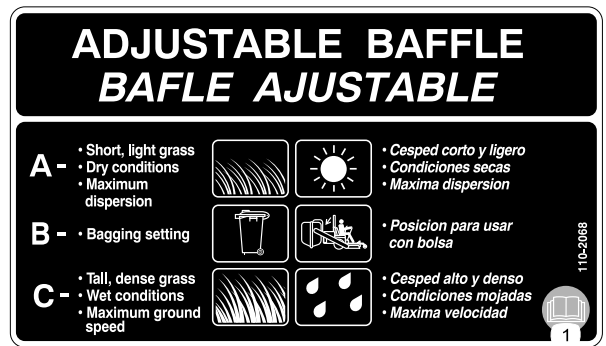

110-2068

decal110-2068

1. Read the *Operator's Manual*.

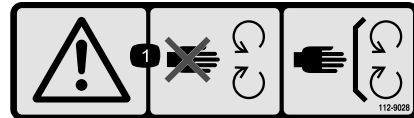

112-9028

decal112-9028

1. Warning—stay away from moving parts; keep all guards in place.

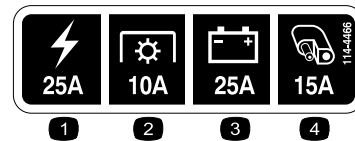

114-4466

decal114-4466

1. Main (25 A)
2. PTO (10 A)
3. Charge (25 A)
4. Auxiliary (15 A)

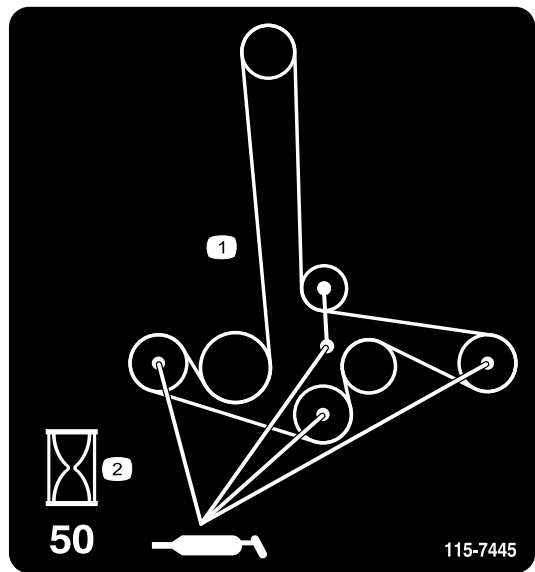

115-7445

decal115-7445

1. Grease pulleys and spindles
2. Maintenance interval—50 hours

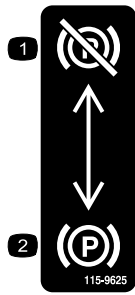

115-9625

decal115-9625

1. Parking brake—disengaged
2. Parking brake—engaged

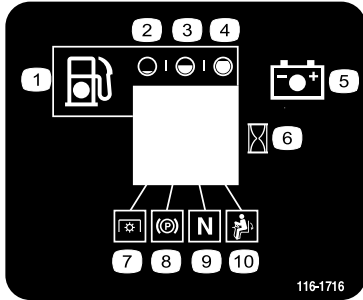

116-1716

decal116-1716

1. Fuel
2. Empty
3. Half
4. Full
5. Battery
6. Hour meter
7. PTO
8. Parking brake
9. Neutral
10. Operator-presence switch



116-4858

decal116-4858



116-8726

decal116-8726

1. Read the *Operator's Manual* for recommended hydro oil.

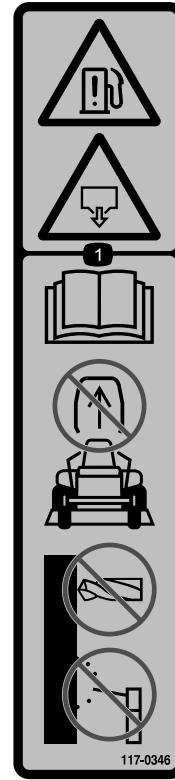

117-0346

decal117-0346

1. Fuel leak hazard—read the *Operator's Manual*; do not attempt to remove the roll bar; do not weld, drill, or modify the roll bar in any way.



117-3848

decal117-3848

1. Thrown object hazard—keep bystanders a safe distance from the machine.
2. Thrown object hazard, mower—do not operate the machine without deflector, discharge cover, or grass collection system in place.
3. Cutting/dismemberment of hand or foot—stay away from moving parts; keep all guards and shields in place.

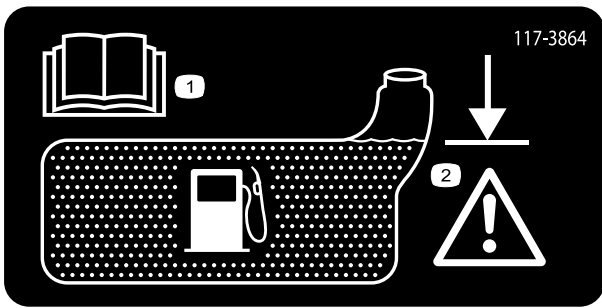

decal117-3864

117-3864

1. Read the *Operator's Manual*.
2. Fill to bottom of filler neck; warning—do not overfill the tank.

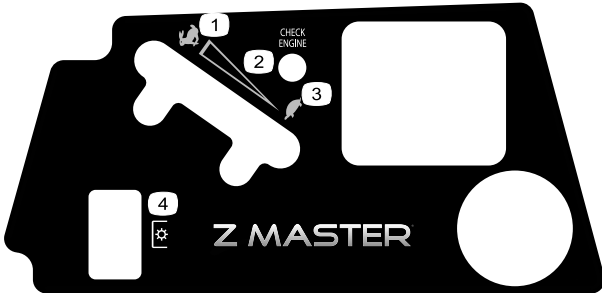

decal121-7586

121-7586

1. Fast
2. Variable speed control
3. Slow
4. Power takeoff (PTO)

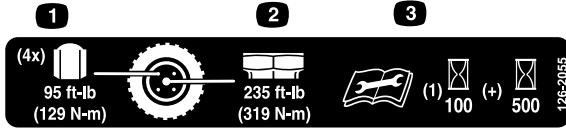

decal126-2055

126-2055

1. Wheel lug-nut torque 129 N·m (95 ft-lb) (4x)
2. Wheel hub-nut torque 319 N·m (235 ft-lb)
3. Read and understand the *Operator's manual* before performing any maintenance, check torque after first 100 hours then every 500 hours thereafter.

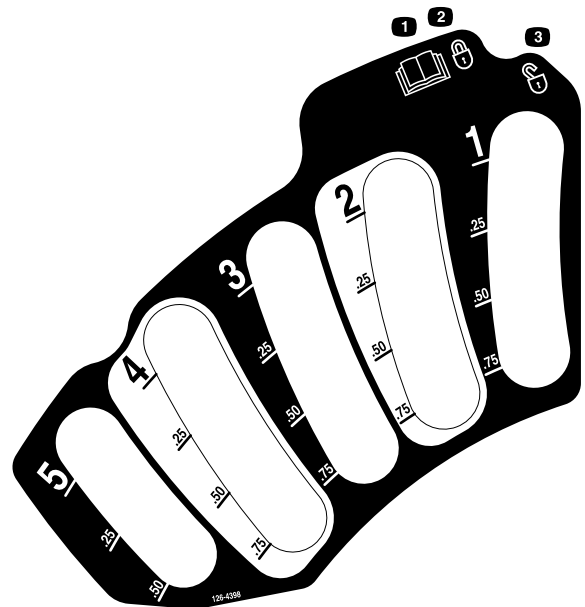

decal126-4398

126-4398

1. Read the *Operator's manual*
2. Lock
3. Unlock

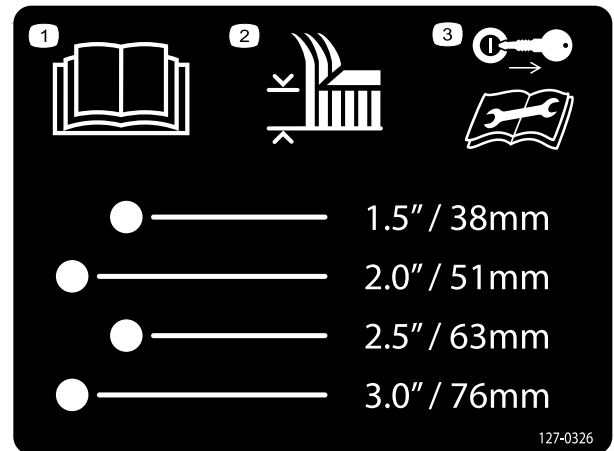

decal127-0326

127-0326

1. Read the *Operator's Manual*.
2. Height-of-cut
3. Remove the key from the ignition and read the *Operator's Manual* before performing maintenance or servicing the machine.

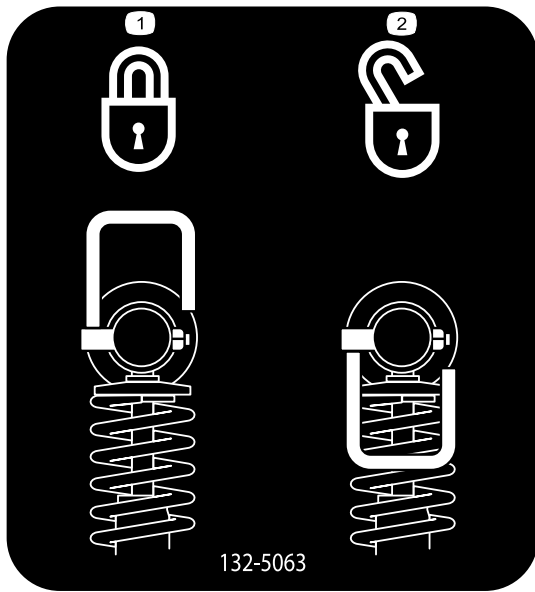

132-5063

decal132-5063

1. Cam lock

2. Cam unlock

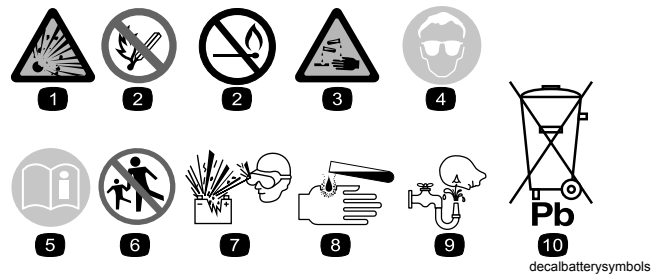

decalbatterysymbols

Battery Symbols

Some or all of these symbols are on your battery.

1. Explosion hazard
2. No fire, open flame, or smoking
3. Caustic liquid/chemical burn hazard
4. Wear eye protection.
5. Read the *Operator's Manual*.
6. Keep bystanders a safe distance from the battery.
7. Wear eye protection; explosive gases can cause blindness and other injuries.
8. Battery acid can cause blindness or severe burns.
9. Flush eyes immediately with water and get medical help fast.
10. Contains lead; do not discard



decaloemmark

Manufacturer's Mark

1. Indicates the blade is identified as a part from the original machine manufacturer.

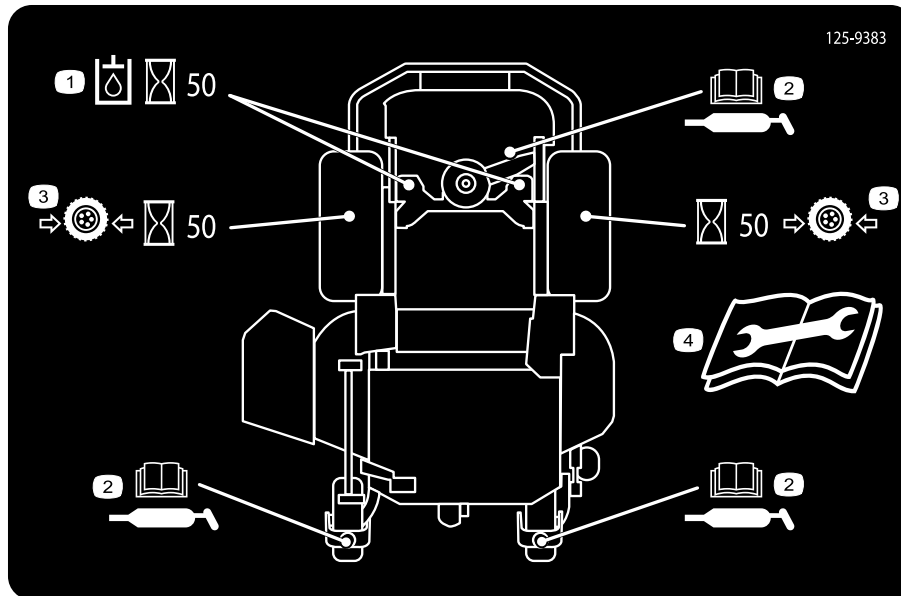

125-9383

125-9383

decal125-9383

1. Check hydraulic fluid every 50 operating hours.
2. Read the *Operator's Manual* for information on lubricating the machine.
3. Check the tire pressure every 50 operating hours.
4. Read the *Operator's Manual* before servicing or performing maintenance.



132-0871

decal132-0871

Note: This machine complies with the industry standard stability test in the static lateral and longitudinal tests with the maximum recommended slope indicated on the decal. Review the instructions for operating the machine on slopes in the *Operator's Manual* as well as the conditions in which you would operate the machine to determine whether you can operate the machine in those conditions on that day and at that site. Changes in the terrain can result in a change in slope operation for the machine. If possible, keep the cutting units lowered to the ground while operating the machine on slopes. Raising the cutting units while operating on slopes can cause the machine to become unstable.

1. Warning—read the *Operator's Manual*; do not operate this machine unless you are trained; wear hearing protection.
2. Cutting, dismembering, and entanglement hazard—keep hands away from moving parts; keep all guards and shields in place.
3. Thrown object hazard—keep bystanders away.
4. Ramp hazard—when loading onto a trailer, do not use dual ramps; only use a singular ramp wide enough for the machine and that has an incline less than 15° ; back up the ramp (in reverse) and drive forward off the ramp.
5. Bodily harm hazard—do not carry passengers; look behind you when mowing in reverse.
6. Tipping hazard on slopes—do not use on slopes near open water; do not use on slopes greater than 15° .



132-5067

decal132-5067

Product Overview

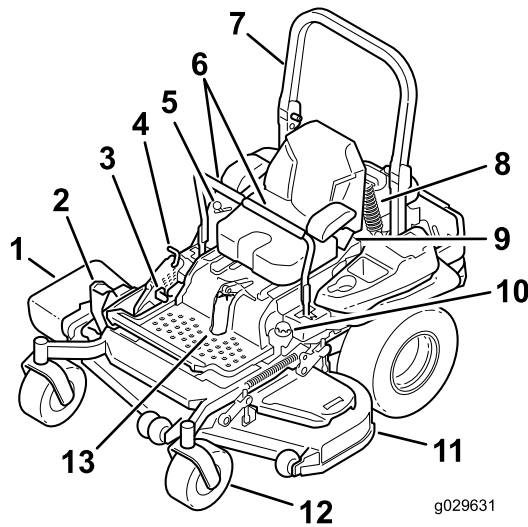

Figure 4

- | | |
|----------------------------------|--------------------------|
| 1. Side-discharge deflector | 8. Rear-shock assembly |
| 2. Height-of-cut deck-lift pedal | 9. Seat belt |
| 3. Parking-brake lever | 10. Fuel cap |
| 4. Transport lock | 11. Mower deck |
| 5. Controls | 12. Caster wheel |
| 6. Motion-control levers | 13. Front-shock assembly |
| 7. Roll bar | |

Controls

Become familiar with all the controls before you start the engine and operate the machine (Figure 4 and Figure 5).

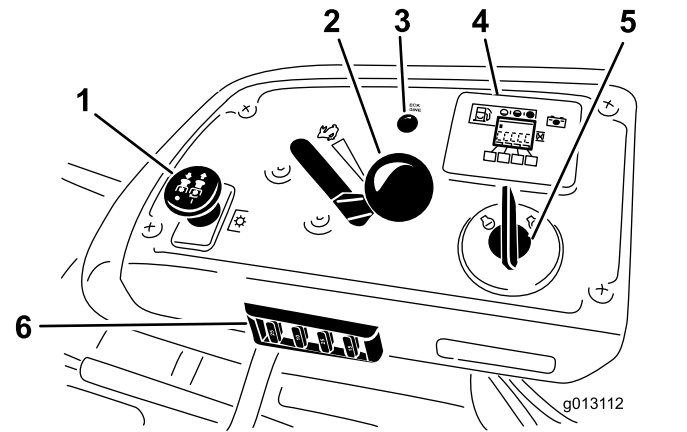

Figure 5

- | | |
|--------------------------------------|---|
| 1. PTO Switch | 4. Hour meter/Safety-interlock display/Fuel gauge |
| 2. Throttle control | 5. Ignition switch |
| 3. Malfunction-indicator light (MIL) | 6. Fuses |

Fuel Gauge

The fuel gauge is located with the hour meter, and the bars light up when the ignition switch is on (Figure 6).

The indicator light appears when the fuel level is low—approximately 3.8 L (1 US gallon) remaining in the fuel tank.

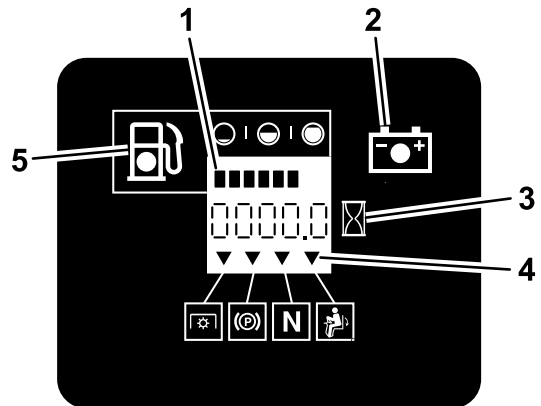

Figure 6

- | | |
|----------------------|-----------------------------|
| 1. Fuel gauge (bars) | 4. Safety-interlock symbols |
| 2. Battery light | 5. Low-fuel indicator light |
| 3. Hour meter | |

Hour Meter

The hour meter records the number of hours the engine has operated. It operates when the engine is running. Use these times for scheduling regular maintenance (Figure 6).

Safety-Interlock Indicators

There are symbols on the hour meter and they indicate with a black triangle that the interlock component is in the correct position ([Figure 6](#)).

Battery-Indicator Light

When you initially turn the ignition key to the RUN position for a few seconds, the battery voltage displays in the area where the hours are normally displayed.

The battery light turns on when the ignition is turned on and when the charge is below the correct operating level ([Figure 5](#)).

Throttle Control

The throttle control is variable between the FAST and SLOW positions.

Blade-Control Switch (PTO)

Use the blade-control switch (PTO) to engage the electric clutch and drive the mower blades. Pull the switch up to engage the blades and release. To disengage the blades, push the blade-control switch (PTO) down or move a motion-control lever into the NEUTRAL-LOCK position.

Ignition Switch

This switch is used to start the mower engine and has 3 positions: **Start**, **Run**, and **Off**.

Motion-Control Levers

Use the motion-control levers to drive the machine forward and reverse, and to turn either direction.

Neutral-Lock Position

Use the NEUTRAL-LOCK position with the safety-interlock system to engage and to determine the NEUTRAL position.

Fuel-Shutoff Valve

Close the fuel-shutoff valve (under the seat) when transporting or storing the mower.

Electronic Control Unit Malfunction Indicator Light

The electronic control unit (ECU) continuously monitors the operation of the EFI system.

If the system detects a problem or fault, the malfunction indicator light (MIL) illuminates.

The MIL is the red light located in the right console panel.

If the MIL illuminates, perform the initial troubleshooting checks; refer to the MIL section in [Troubleshooting \(page 73\)](#).

If these checks do not correct the problem, further diagnosis and servicing by an Authorized Service Dealer is necessary.

Attachments/Accessories

A selection of Toro approved attachments and accessories is available for use with the machine to enhance and expand its capabilities. Contact your Authorized Service Dealer or Distributor or go to www.Toro.com for a list of all approved attachments and accessories.

Specifications

Note: Specifications and design are subject to change without notice.

Width

Without Deck	135 cm (53 inches)
Deflector Up	157 cm (62 inches)
Deflector Down	192 cm (76 inches)

Length

Roll Bar Up	211 cm (83 inches)
Roll Bar Down	215 cm (85 inches)

Height

Roll Bar Up	Roll Bar Down
179 cm (71 inches)	127.8 cm (50.3 inches)

Weight

Model	Weight
74991	587 kg (1,295 lbs)

Operation

Note: Determine the left and right sides of the machine from the normal operating position.

Adding Fuel

- For best results, use only clean, fresh (less than 30 days old), unleaded gasoline with an octane rating of 87 or higher ((R+M)/2 rating method).
- **Ethanol:** Gasoline with up to 10% ethanol (gasohol) or 15% MTBE (methyl tertiary butyl ether) by volume is acceptable. Ethanol and MTBE are not the same. Gasoline with 15% ethanol (E15) by volume is not approved for use. **Never use gasoline that contains more than 10% ethanol by volume**, such as E15 (contains 15% ethanol), E20 (contains 20% ethanol), or E85 (contains up to 85% ethanol). Using unapproved gasoline may cause performance problems and/or engine damage which may not be covered under warranty.
- **Do not** use gasoline containing methanol.
- **Do not** store fuel either in the fuel tank or fuel containers over the winter unless a fuel stabilizer is used.
- **Do not** add oil to gasoline.

⚠ DANGER

In certain conditions, gasoline is extremely flammable and highly explosive. A fire or explosion from gasoline can burn you and others and can damage property.

- **Fill the fuel tank outdoors, in an open area, when the engine is cold. Wipe up any gasoline that spills.**
- **Never fill the fuel tank inside an enclosed trailer.**
- **Do not fill the fuel tank completely full. Add gasoline to the fuel tank until the level is 6 to 13 mm (1/4 to 1/2 inch) below the bottom of the filler neck. This empty space in the tank allows gasoline to expand.**
- **Never smoke when handling gasoline, and stay away from an open flame or where gasoline fumes may be ignited by a spark.**
- **Store gasoline in an approved container and keep it out of the reach of children. Never buy more than a 30-day supply of gasoline.**
- **Do not operate without entire exhaust system in place and in proper working condition.**

⚠ DANGER

In certain conditions during fueling, static electricity can be released, causing a spark that can ignite the gasoline vapors. A fire or explosion from gasoline can burn you and others and can damage property.

- Always place gasoline containers on the ground away from your vehicle before filling.
- Do not fill gasoline containers inside a vehicle or on a truck or trailer bed, because interior carpets or plastic truck bed liners may insulate the container and slow the loss of any static charge.
- When practical, remove gas-powered equipment from the truck or trailer and refuel the equipment with its wheels on the ground.
- If this is not possible, then refuel such equipment on a truck or trailer from a portable container rather than from a gasoline-dispenser nozzle.
- If you must use a gasoline-dispenser nozzle, keep the nozzle in contact with the rim of the fuel tank or container opening at all times until fueling is complete.

⚠ WARNING

Gasoline is harmful or fatal if swallowed. Long-term exposure to vapors can cause serious injury and illness.

- Avoid prolonged breathing of vapors.
- Keep face away from nozzle and gas tank or conditioner bottle opening.
- Avoid contact with skin; wash off spills with soap and water.

Using Stabilizer/Conditioner

Use a fuel stabilizer/conditioner in the machine to provide the following benefits:

- Keeps gasoline fresh during storage of 90 days or less. For longer storage it is recommended that the fuel tank be drained.
- Cleans the engine while it runs
- Eliminates gum-like varnish buildup in the fuel system, which causes hard starting

Important: Do not use fuel additives containing methanol or ethanol.

Add the correct amount of gasoline stabilizer/conditioner to the gasoline.

Note: A fuel stabilizer/conditioner is most effective when mixed with fresh gasoline. To minimize the chance of varnish deposits in the fuel system, use fuel stabilizer at all times.

Filling the Fuel Tank

1. Park the machine on level ground.
2. Shut the engine off and set the parking brake.
3. Clean around the fuel-tank cap.
4. Fill the fuel tank to the bottom of the filler neck (Figure 7).

Note: Ensure that there is empty space in the tank to allow the gasoline to expand.

Note: Do not fill the fuel tank completely full. Fill the fuel tank to the bottom of the filler neck.

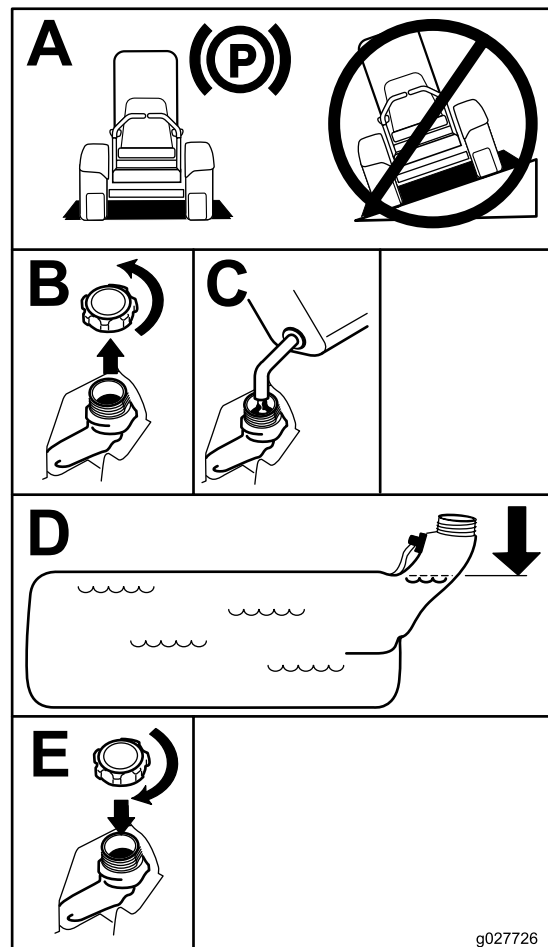

Figure 7

g027726

Checking the Engine-Oil Level

Before you start the engine and use the machine, check the oil level in the engine crankcase; refer to [Checking the Engine-Oil Level \(page 41\)](#).

Breaking in a New Machine

New engines take time to develop full power. Mower decks and drive systems have higher friction when new, placing additional load on the engine. Allow 40 to 50 hours of break-in time for new machines to develop full power and best performance.

Using the Rollover-Protection System (ROPS)

⚠ WARNING

To avoid injury or death from rollover: keep the roll bar in the fully raised, locked position and use the seat belt.

Ensure that the seat is secured to the machine.

⚠ WARNING

There is no rollover protection when the roll bar is in the down position.

- Lower the roll bar only when absolutely necessary.
- Do not wear the seat belt when the roll bar is in the down position.
- Drive slowly and carefully.
- Raise the roll bar as soon as clearance permits.
- Check carefully for overhead clearances (i.e., branches, doorways, electrical wires) before driving under any objects, and do not contact them.

Important: Ensure that the seat is secured to the machine.

1. To lower the roll bar, apply forward pressure to the upper part of the roll bar.
2. Pull both knobs out and rotate them 90 degrees so that they are not engaged ([Figure 8](#)).

3. Lower the roll bar to the down position ([Figure 8](#)).

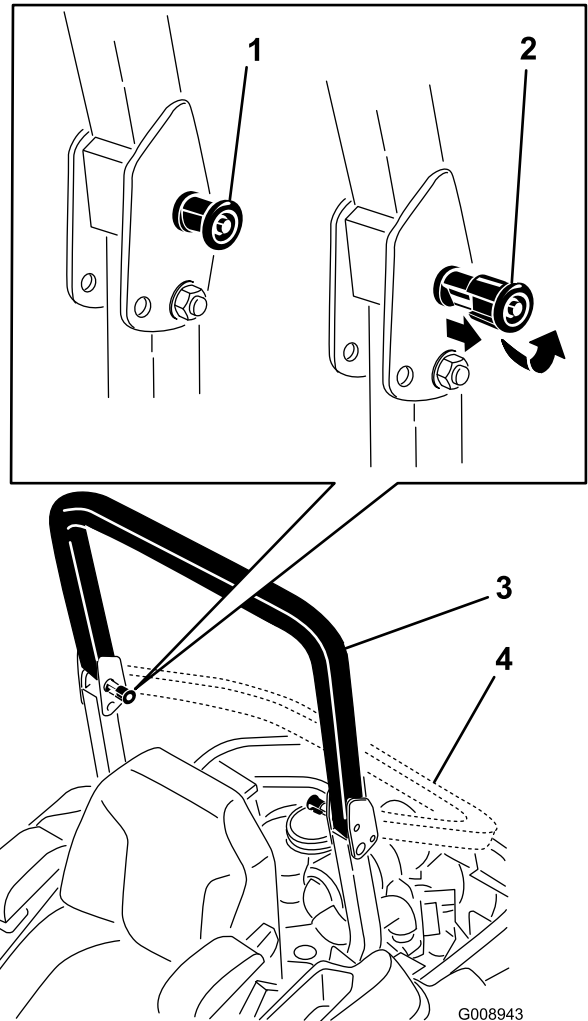

Figure 8

1. ROPS knob
2. Pull the ROPS knob out and rotate it 90 degrees.
3. Roll bar in the upright position
4. Roll bar in the folded position

4. To raise the roll bar, raise the roll bar to the operate position and rotate the knobs so that they move partially into the grooves ([Figure 8](#)).
5. Raise the roll bar to the full upright position while pushing on the upper roll bar so that the pins snap into position when the holes align with the pins ([Figure 8](#)).
6. Push on the roll bar and ensure that both pins are engaged.

Important: Always use the seat belt with the roll bar in the raised position.

Entering the Operating Position

Use the mower deck as a step to get into the operating position (Figure 9).

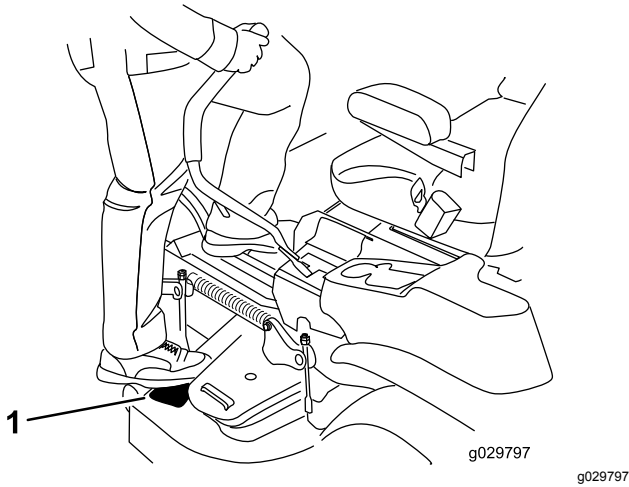

Figure 9

1. Mower deck

Think Safety First

Please read all safety instructions and symbols in the safety section. Knowing this information could help you or bystanders avoid injury.

⚠ DANGER

Operating the machine on wet grass or steep slopes can cause sliding and loss of control.

- Do not operate on slopes greater than 15 degrees.
- Reduce speed and use extreme caution on slopes.
- Do not operate the machine near water.

⚠ DANGER

Wheels dropping over edges can cause rollovers, which may result in serious injury, death, or drowning.

Do not operate the machine near drop-offs.

⚠ DANGER

Operating the machine while the roll bar is down may lead to serious injury or death in the event of a rollover.

Always keep the roll bar in the fully raised and locked position and use the seat belt.

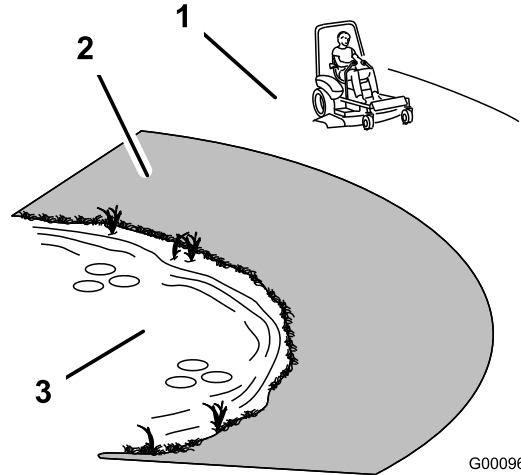

Figure 10

1. Safe Zone—use the machine here on slopes less than 15 degrees or flat areas.
2. Danger Zone—use a walk-behind mower and/or a hand trimmer on slopes greater than 15 degrees, near drop-offs and water.
3. Water

⚠ CAUTION

This machine produces sound levels in excess of 85 dBA at the operator's ear and can cause hearing loss through extended periods of exposure.

Wear hearing protection when operating this machine.

Use protective equipment for your eyes, ears, hands, feet, and head.

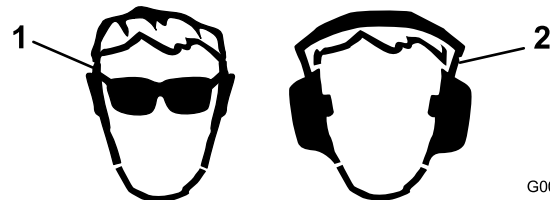

Figure 11

1. Wear eye protection.
2. Wear hearing protection.

Operating the Parking Brake

Always set the parking brake when you stop the machine or leave it unattended.

Setting the Parking Brake

⚠ WARNING

The parking brake may not hold a machine parked on a slope and could cause personal injury or property damage.

Do not park the machine on slopes unless the wheels are chocked or blocked.

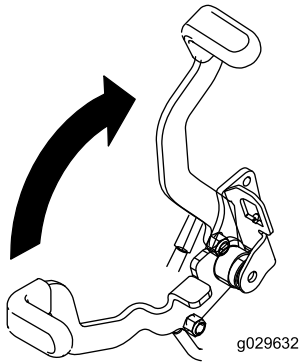

Figure 12

g029632

g029632

Releasing the Parking Brake

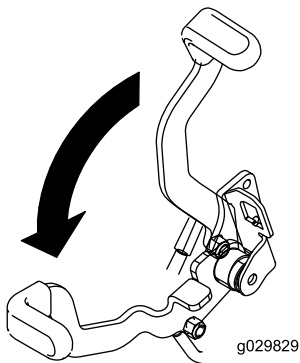

Figure 13

g029829

g029829

Operating the Mower Blade-Control Switch (PTO)

The blade-control switch (PTO) starts and stops the mower blades and any powered attachments.

Engaging the Blade-Control Switch (PTO)

Note: Engaging the blade-control switch (PTO) with the throttle position at half or less causes excessive wear to the drive belts.

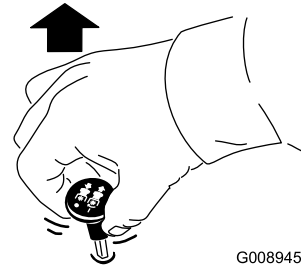

G008945

g008945

Figure 14

Disengaging the Blade-Control Switch (PTO)

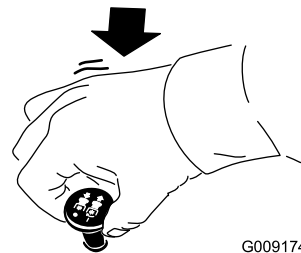

G009174

g009174

Figure 15

Operating the Throttle

You can move the throttle control between FAST and SLOW positions (Figure 16).

Always use the FAST position when turning on the mower deck with the blade-control switch (PTO).

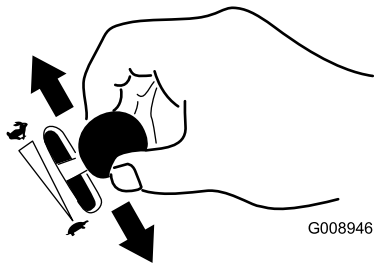

G008946

Figure 16

g008946

Operating the Ignition Switch

1. Turn the ignition key to the START position (Figure 17).

Note: When the engine starts, release the key.

Important: Do not engage the starter for more than 5 seconds at a time. If the engine fails to start, wait 15 seconds between attempts. Failure to follow these instructions can burn out the starter motor.

Note: You may need multiple attempts to start the engine when you start it the first time after the fuel system has been without fuel completely.

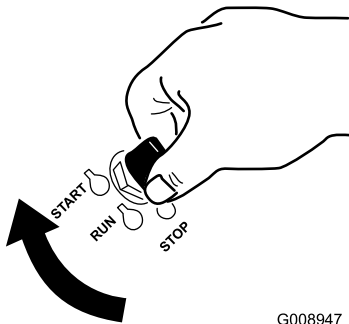

G008947

Figure 17

g008947

2. Turn the ignition key to the STOP position to shut off the engine.

Using the Fuel-Shutoff Valve

The fuel-shutoff valve is located under the seat. Move the seat forward to access it.

Close the fuel-shutoff valve for transport, maintenance, and storage.

Ensure that the fuel-shutoff valve is open when starting the engine.

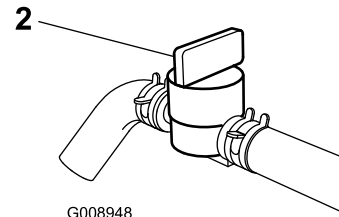
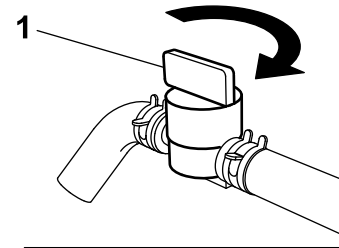

G008948

Figure 18

g008948

1. On

2. Off

Starting and Shutting Off the Engine

Starting the Engine

1. Raise the ROPS up, lock it into place, sit on the seat, and fasten the seat belt.
2. Move the motion-control levers to the NEUTRAL-LOCK position.
3. Set the parking brake; refer to [Setting the Parking Brake \(page 20\)](#).
4. Move the blade-control switch (PTO) to the OFF position (Figure 19).
5. Move the throttle lever midway between the SLOW and FAST positions.

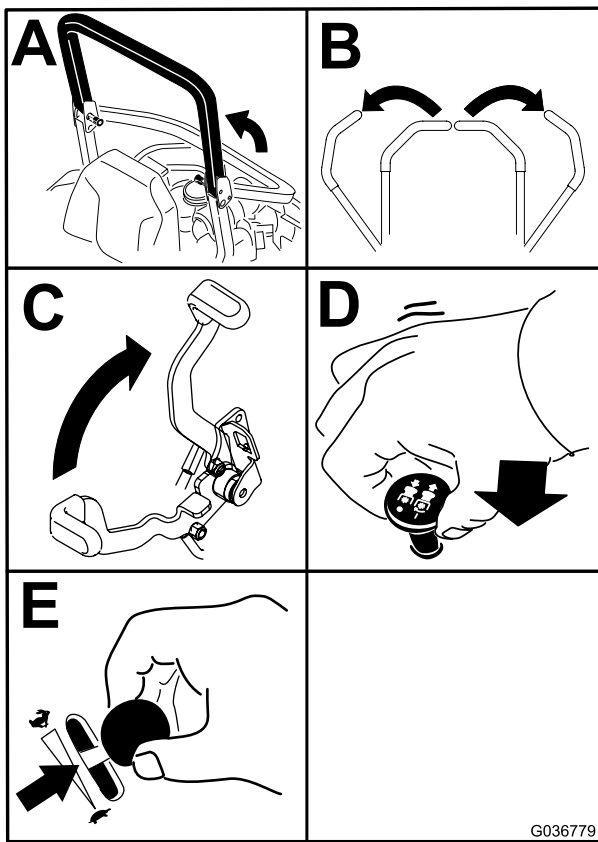

Figure 19

G036779

g036779

- Turn the ignition key to the START position (Figure 20).

Note: When the engine starts, release the key.

Important: Do not engage starter for more than 5 seconds at a time. If the engine fails to start, wait 15 seconds between attempts. Failure to follow these instructions can burn out the starter motor.

Note: You may need to attempt to start the engine multiple times when you start it for the first time after the fuel system has been without fuel completely.

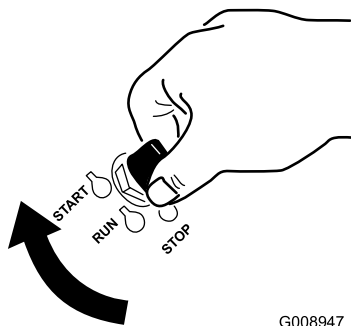

Figure 20

G008947

g008947

- Off
- Run
- Start

Shutting Off the Engine

⚠ CAUTION

Children or bystanders may be injured if they move or attempt to operate the machine while it is unattended.

Always remove the ignition key and set the parking brake when leaving the machine unattended, even if just for a few minutes.

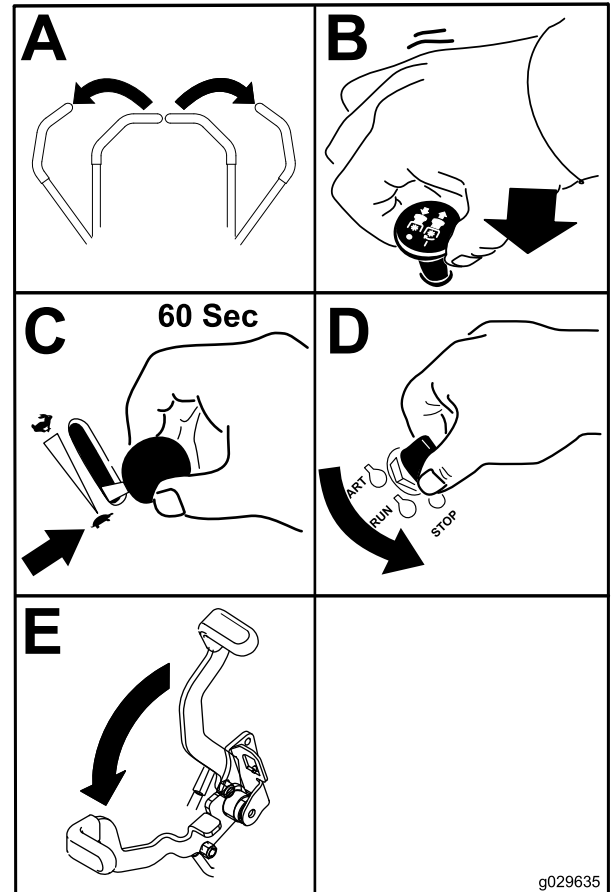

Figure 21

g029635

g029635

Important: Make sure that you close the fuel-shutoff valve before transporting or storing the machine, as fuel leakage may occur. Set the parking brake before transporting the machine. Make sure to remove the key as the fuel pump may run and cause the battery to lose charge.

Using the Safety-Interlock System

⚠ CAUTION

If the safety-interlock switches are disconnected or damaged, the machine could operate unexpectedly, causing personal injury.

- Do not tamper with the interlock switches.
- Check the operation of the interlock switches daily and replace any damaged switches before operating the machine.

Understanding the Safety-Interlock System

The safety-interlock system is designed to prevent the engine from starting unless:

- The parking brake is engaged.
- The blade-control switch (PTO) is disengaged.
- The motion-control levers are in the NEUTRAL-LOCK position.

The safety-interlock system also is designed to shut off the engine when you move the traction controls from the locked position with the parking brake engaged or if you rise from the seat when the PTO is engaged.

The hour meter has symbols to notify you when the interlock component is in the correct position. When the component is in the correct position, a triangle lights up in the corresponding square.

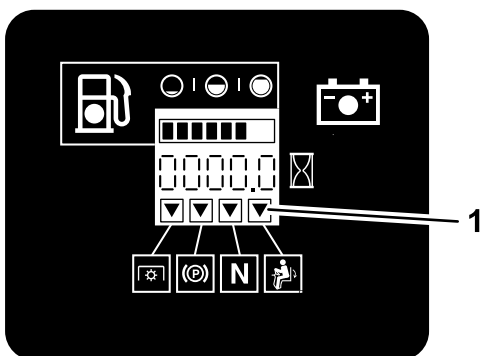

G009181

g009181

Figure 22

1. Triangles light up when the interlock components are in the correct position.

Testing the Safety-Interlock System

Service Interval: Before each use or daily

Test the safety-interlock system before you use the machine each time. If the safety system does not operate as described below, have an Authorized Service Dealer repair the safety system immediately.

1. Sit on the seat, engage the parking brake and move the blade-control switch (PTO) to the ON position. Try starting the engine; the engine should not crank.
2. Sit on the seat, engage the parking brake and move the blade-control switch (PTO) to the OFF position. Move either motion-control lever (out of the NEUTRAL-LOCK position). Try starting the engine; the engine should not crank. Repeat for the other control lever.
3. Sit on the seat, engage the parking brake, move the blade-control switch (PTO) to the OFF position, and move the motion-control levers to the NEUTRAL-LOCK position. Start the engine. While the engine is running, release the parking brake, engage the blade-control switch (PTO), and rise slightly from the seat; the engine should shut off.
4. Sit on the seat, engage the parking brake, move the blade-control switch (PTO) to the OFF position, and move the motion-control levers to NEUTRAL-LOCK position. Start the engine. While the engine is running, center either motion-control lever and move it forward or reverse; the engine should shut off. Repeat for the other motion-control lever.
5. Sit on the seat, disengage the parking brake, move the blade-control switch (PTO) to the OFF position, and move the motion-control levers to NEUTRAL-LOCK position. Try starting the engine; the engine should not crank.

Driving Forward or Backward

The throttle control regulates the engine speed as measured in rpm (revolutions per minute). Place the throttle control in the FAST position for best performance. Always operate in the full throttle position when mowing.

⚠ CAUTION

Machine can spin very rapidly. You may lose control of machine and injure yourself or damage the machine.

- Use caution when making turns.
- Slow the machine down before making sharp turns.

Using the Motion-Control Levers

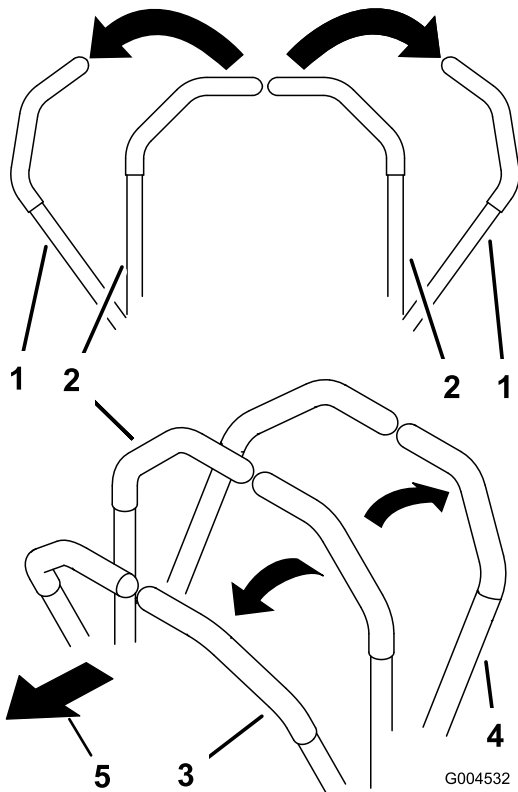

Figure 23

g004532

- | | |
|---|---------------------|
| 1. Motion-control lever—NEUTRAL-LOCK position | 4. Backward |
| 2. Center, unlocked position | 5. Front of machine |
| 3. Forward | |

Driving Forward

Note: The engine shuts off if you move the traction-control levers with the parking brake engaged.

To stop, pull the motion-control levers to the NEUTRAL position.

1. Release the parking brake; refer to [Releasing the Parking Brake \(page 20\)](#).
2. Move the levers to the center, unlocked position.
3. To go forward, slowly push the motion-control levers forward ([Figure 24](#)).

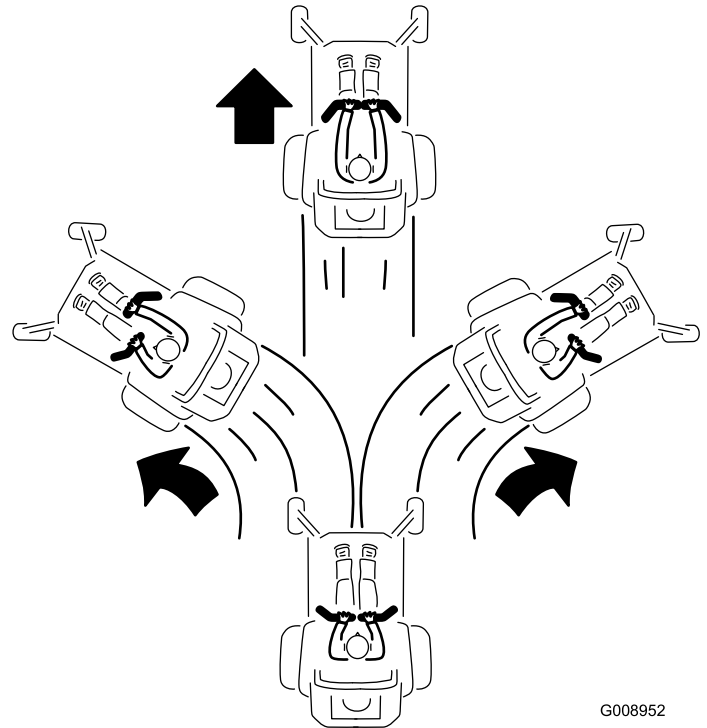
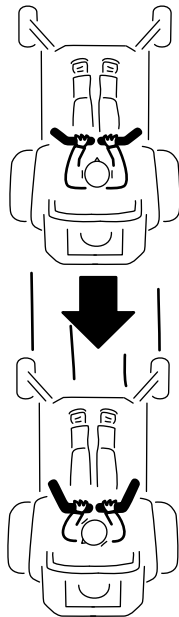

Figure 24

g008952

Driving Backward

1. Move the levers to the center, unlocked position.
2. To go backward, slowly pull the motion-control levers rearward ([Figure 25](#)).



G008953

g008953

Figure 25

Shutting Off the Machine

To shut off the machine, move the motion-control levers to neutral and then to the NEUTRAL-LOCK position, disengage the blade-control switch (PTO), and turn the ignition key to the OFF position.

Set the parking brake when you leave the machine; refer to [Setting the Parking Brake \(page 20\)](#). Remove the key from the ignition switch.

⚠ CAUTION

Children or bystanders may be injured if they move or attempt to operate the machine while it is unattended.

Always remove the ignition key and set the parking brake when leaving the machine unattended, even if just for a few minutes.

Adjusting the Height of Cut

Using the Transport Lock

The transport lock has 2 positions, and is used with the deck-lift pedal. There is a LOCK position and an UNLOCK position for the transport position of the mower deck ([Figure 26](#)).

Adjusting the Height-of-Cut Pin

Adjust the height-of-cut from 25 to 140 mm (1 to 5-1/2 inches) in 6 mm (1/4 inch) increments by moving the clevis pin into different hole locations.

1. Move the transport lock to the LOCK position.
2. Push on the deck-lift pedal with your foot and raise the mower deck to the Transport position (also the 140 mm or 5-1/2 inch cutting-height position) as shown in [Figure 26](#).
3. To adjust, rotate the pin 90 degrees and remove the pin from the height-of-cut bracket ([Figure 27](#)).
4. Select a hole in the height-of-cut bracket corresponding to the height-of-cut desired, and insert the pin ([Figure 27](#)).
5. Push on the deck lift, pull back on the transport lock, and slowly lower the mower deck.

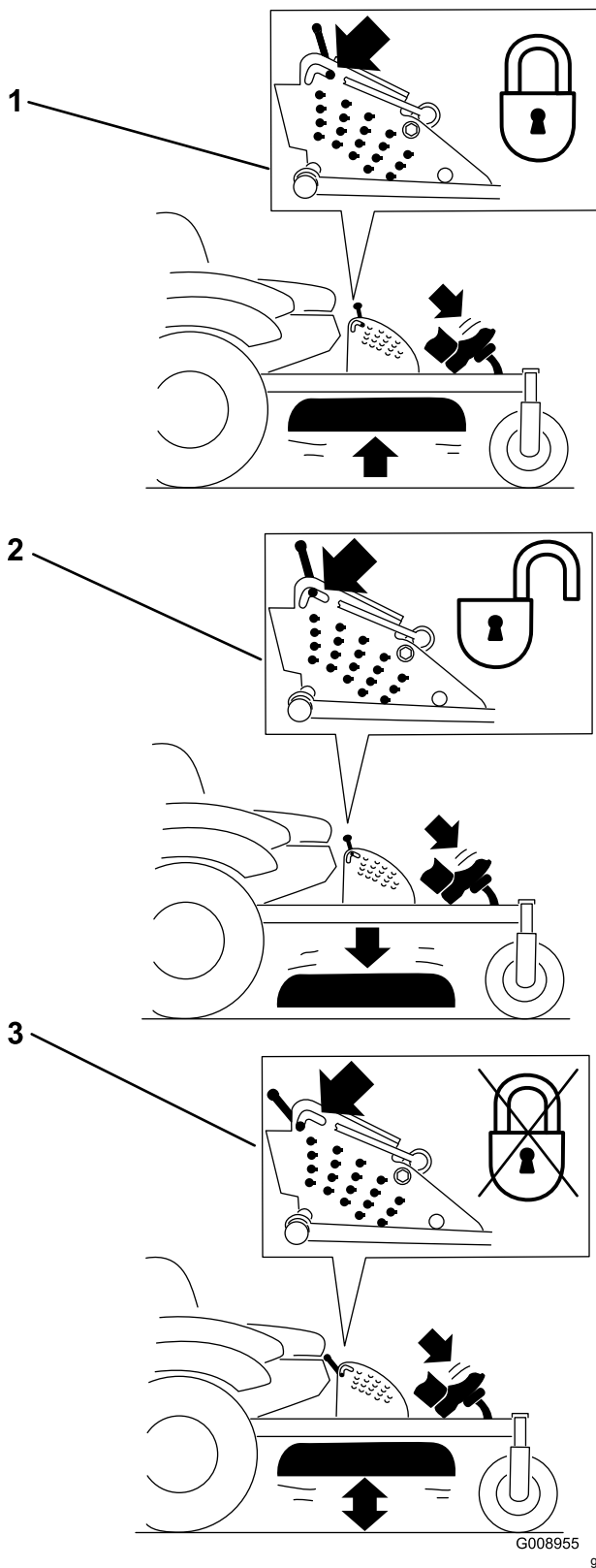

Figure 26

Transport-Lock Positions

1. Transport lock
2. Lock position—The mower deck locks into the transport position.
3. UNLOCK position—The mower deck does not lock into the transport position.

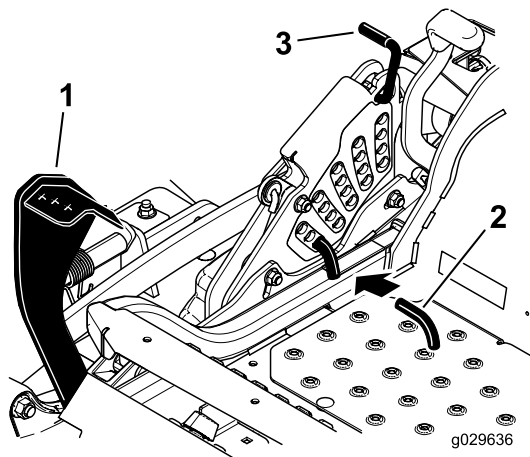

Figure 27

1. Deck-lift pedal
2. Height-of-cut pin
3. Transport lock

g029840

Adjusting the Anti-Scalp Rollers

Whenever you change the height of cut, adjust the height of the anti-scalp rollers.

1. Disengage the blade-control switch (PTO), move the motion-control levers to the NEUTRAL-LOCK position, and set the parking brake.
2. Shut off the engine, remove the key, and wait for all moving parts to stop before leaving the operating position.

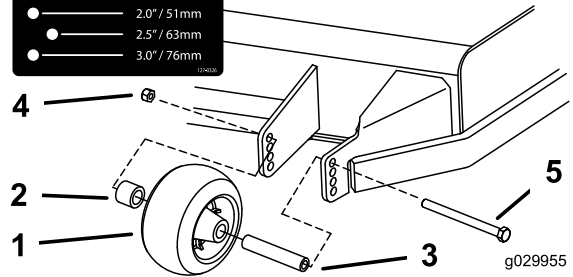
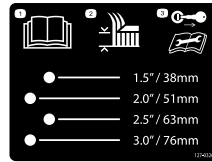

Figure 28

1. Anti-scalp roller
2. Spacer
3. Bushing
4. Flange nut
5. Bolt

g029955

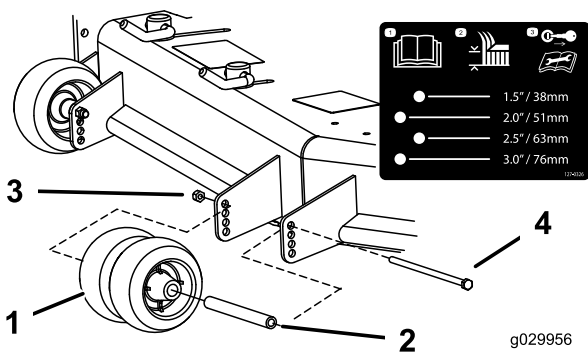

Figure 29

- | | |
|----------------------|---------------|
| 1. Anti-scalp roller | 3. Flange nut |
| 2. Bushing | 4. Bolt |

Adjusting the Flow-Baffle-Cam Locks For Machines with Flow-Baffle Locks Only

You can adjust the mower-discharge flow for different types of mowing conditions. Position the cam locks and baffle to achieve the best quality of cut.

Note: Certain models have nuts and bolts in place of the flow-baffle locks.

1. Disengage the blade-control switch (PTO), move the motion-control levers to the NEUTRAL-LOCK position, and set the parking brake.
2. Shut off the engine, remove the key, and wait for all moving parts to stop before leaving the operating position.
3. To adjust the cam locks, swing the lever up to loosen the cam lock (Figure 30).
4. Adjust the baffle and cam locks in the slots to the desired discharge flow.
5. Swing the lever back over to tighten the baffle and cam locks (Figure 30).
6. If the cam locks do not lock the baffle into place or it is too tight, loosen the lever and then rotate the cam lock. Adjust the cam lock until you achieve the desired locking pressure.

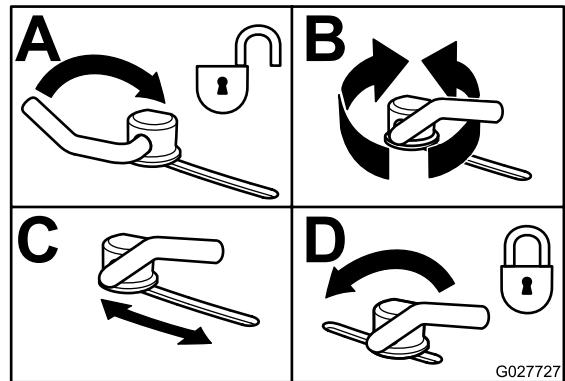

Figure 30

Positioning the Flow Baffle

The following figures are only recommendations for use. Adjustments vary by grass type, moisture content, and height of grass.

Note: If the engine power draws down and the mower ground speed is the same, open up the baffle.

Position A

This is the full rear position. Use this position for the following.

- Short, light grass mowing conditions.
- Dry conditions.
- Smaller grass clippings.
- Propelling grass clippings farther away from the mower.

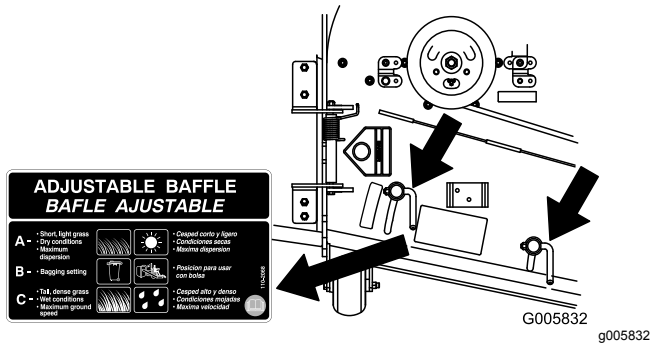

Figure 31

Position B

Use this position when bagging. Always align it with the blower opening.

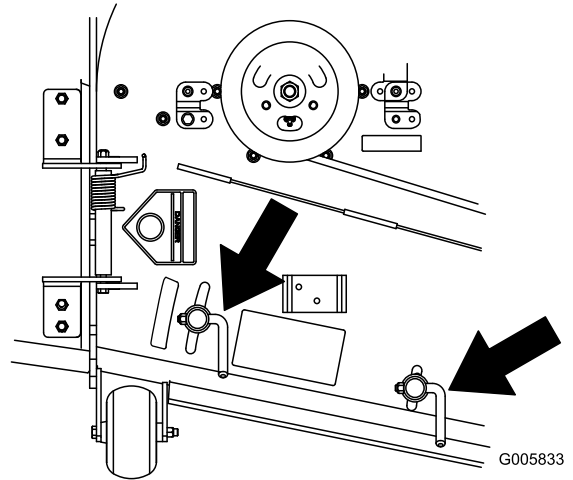

Figure 32

Position C

This is the fully open position. Use this position for the following:

- Tall, dense grass mowing conditions.
- Wet conditions.
- Lowering the engine power consumption.
- Increased ground speed in heavy conditions.

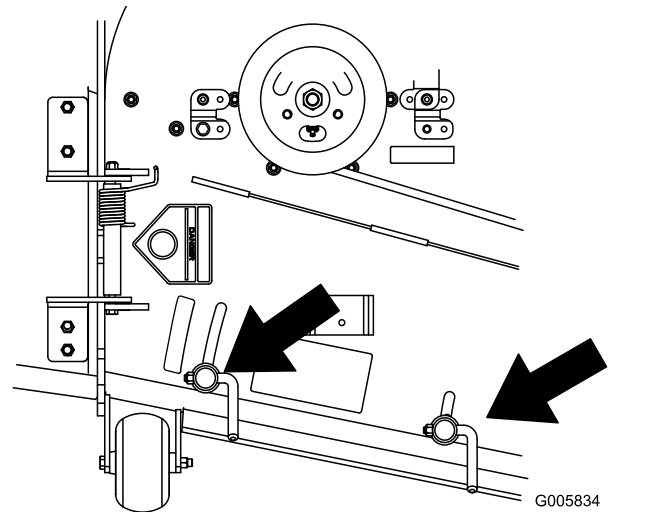

Figure 33

Note: This position is similar to the benefits of the Toro SFS mower.

Positioning the Seat

The seat can move forward and backward. Position the seat where you have the best control of the machine and are most comfortable.

To adjust the seat, move the lever sideways to unlock seat (Figure 34).

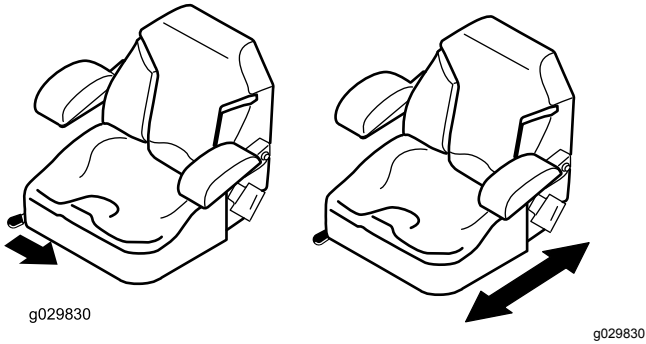

Figure 34

Unlatching the Seat

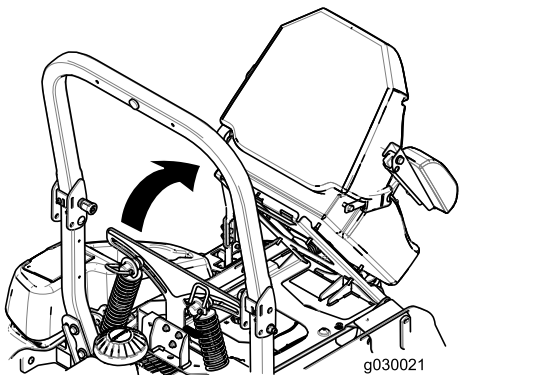
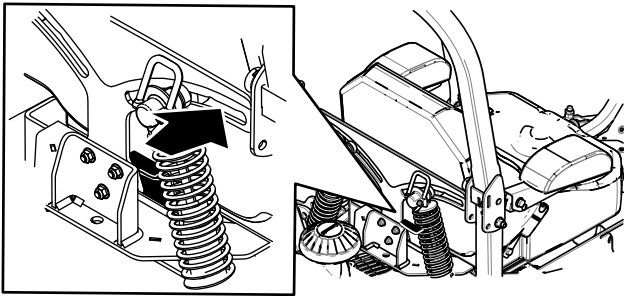

Figure 35

Adjusting the MyRide™ Suspension System

The MyRide™ suspension system adjusts to provide a smooth and comfortable ride. Adjusting the rear 2-shock assemblies is the easiest and quickest adjustment for changing the suspension system. Position the suspension system where you are most comfortable.

Adjusting the Rear-Shock Assemblies

The slots for the rear-shock assemblies have detent positions for reference. You can position the rear-shock assemblies anywhere in the slot, not just in the detent positions.

The following graphic shows the position for a soft or firm ride and the different detent positions (Figure 36).

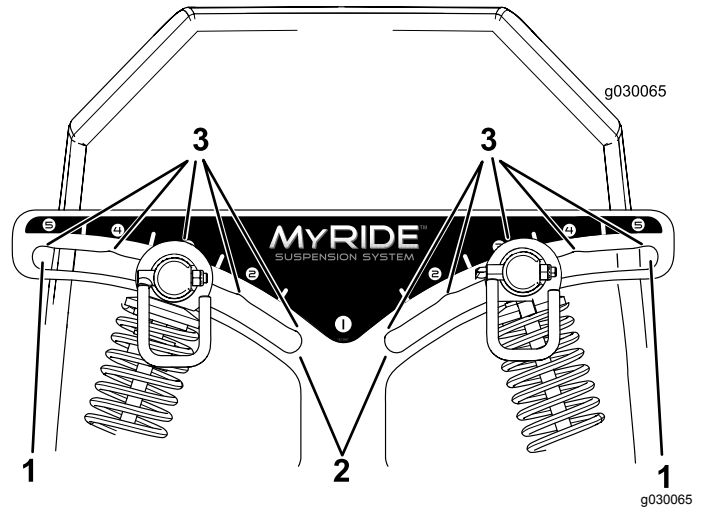
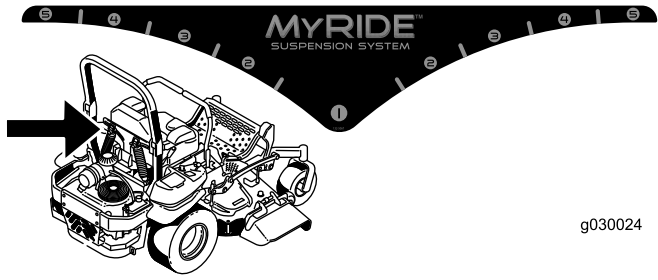

Figure 36

1. Firmest position
2. Softest position
3. Detents in the slots

Note: Ensure that the left and right rear-shock assemblies are always adjusted to the same positions.

Adjust the rear-shock assemblies (Figure 37).



g030024

g030024

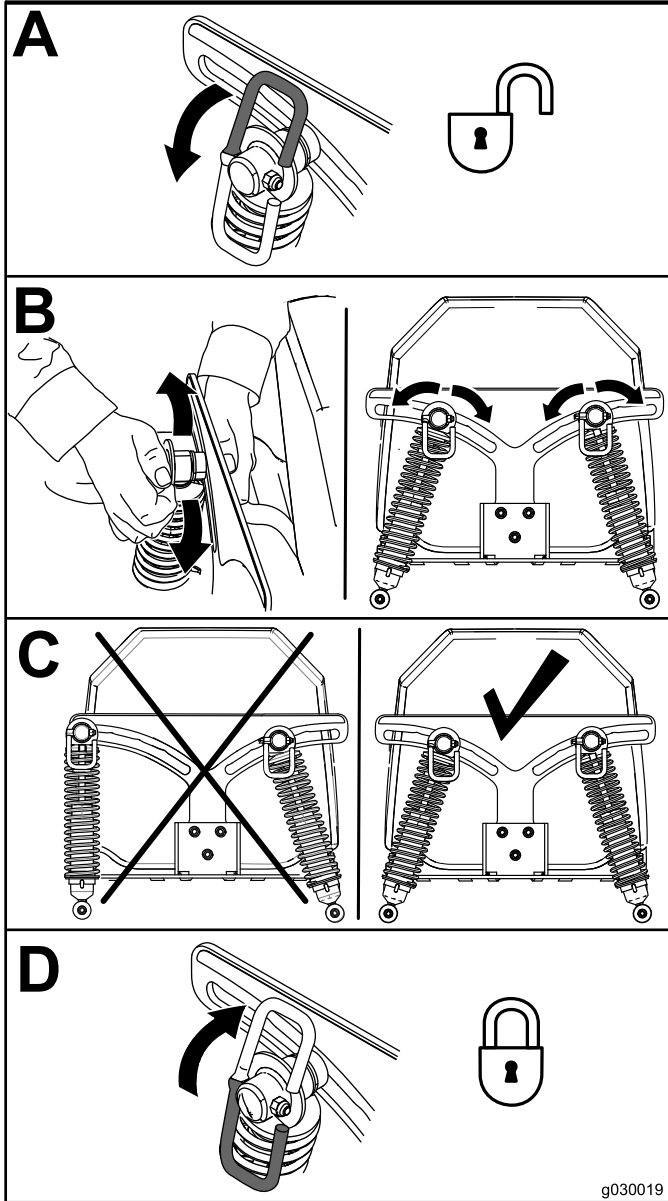

g030019

Figure 37

g030019

Adjusting the Front-Shock Assembly

The front-shock assembly is set at the middle position and is normally not adjusted.

To adjust the front-shock assembly, open the floor pan and adjust it by using a spanner wrench (Toro Part No. 132-5069) or slip-joint pliers (Figure 38).

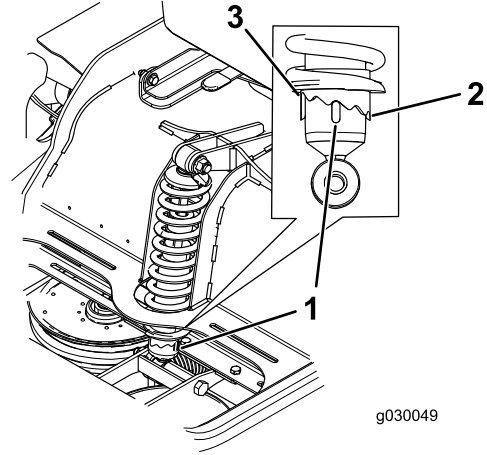

g030049

g030049

Figure 38

1. Middle position
2. Firm ride
3. Soft ride

Using the Drive-Wheel Release Valves

⚠ WARNING

Hands may become entangled in the rotating drive components below the engine deck, which could result in serious injury.

Shut off the engine, remove the key, and wait for all moving parts to stop before accessing the drive-wheel release valves.

⚠ WARNING

The engine and hydraulic drive units can become very hot. Touching a hot engine or hydraulic drive units can cause severe burns.

Wait for the engine and hydraulic drive units to cool completely before accessing the drive-wheel release valves.

The drive-wheel release valves are located in the back of each hydraulic drive unit, under the seat.

Note: Make sure that the release valves are in the fully horizontal position when operating the machine, or severe damage to the hydraulic system could occur.

1. Disengage the blade-control switch (PTO) and turn the ignition key to off. Move the levers to the NEUTRAL-LOCK position and apply the parking brake. Remove the key.
2. Rotate the release-valve levers vertically to push the machine (Figure 39).

Note: This allows the hydraulic fluid to bypass the pump, enabling the wheels to turn.

3. Disengage the parking brake before pushing the machine.

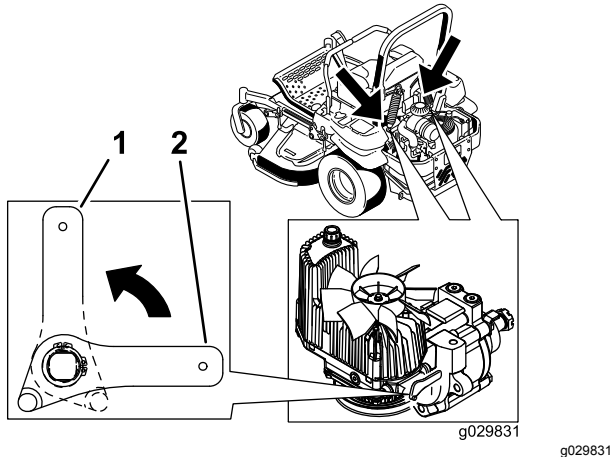

Figure 39

1. Vertical to push the machine
2. Horizontal to run the machine

4. Rotate the release-valve levers horizontally to run the machine (Figure 39).

⚠ DANGER

Without a grass deflector, discharge cover, or a complete grass-catcher assembly mounted in place, you and others are exposed to blade contact and thrown debris. Contact with rotating mower blade(s) and thrown debris cause injury or death.

- **Never remove the grass deflector from the mower because the grass deflector routes material down toward the turf. If the grass deflector is ever damaged, replace it immediately.**
- **Never put your hands or feet under the mower.**
- **Never try to clear the discharge area or mower blades unless you move the blade-control switch (PTO) to the OFF position, rotate the ignition key to the OFF position, and remove the key.**
- **Make sure that the grass deflector is in the down position.**

Using the Side Discharge

The mower has a hinged grass deflector that disperses clippings to the side and down toward the turf.

Transporting the Machine

Use a heavy-duty trailer or truck to transport the machine. Ensure that the trailer or truck has all necessary brakes, lighting, and marking as required by law. Please carefully read all the safety instructions. Knowing this information could help you, your family, pets, or bystanders avoid injury.

⚠ WARNING

Driving on the street or roadway without turn signals, lights, reflective markings, or a slow-moving-vehicle emblem is dangerous and can lead to accidents, causing personal injury.

Do not drive the machine on a public street or roadway.

1. If you are using a trailer, connect it to the towing vehicle and connect the safety chains.
2. If applicable, connect the trailer brakes.
3. Load the machine onto the trailer or truck.
4. Shut off the engine, remove the key, set the brake, and close the fuel valve.
5. Use the metal tie-down loops on the machine to securely fasten it to the trailer or truck with straps, chains, cable, or ropes (Figure 40).

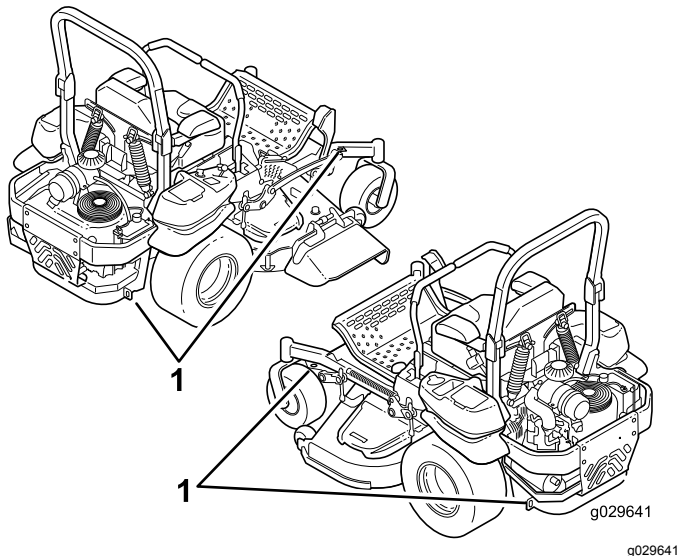

Figure 40

1. Tie-down loops

Loading the Machine

Use extreme caution when loading or the unloading machine onto a trailer or a truck. Use a full-width ramp that is wider than the machine for this procedure. Back the machine up the ramp and drive it forward down the ramp (Figure 41).

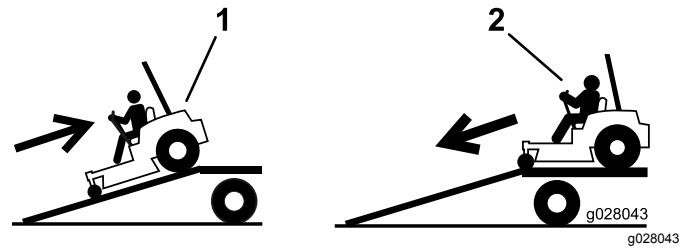

Figure 41

1. Back the machine up the ramp.
2. Drive the machine forward down the ramp.

Important: Do not use narrow individual ramps for each side of the machine.

Ensure that the ramp is long enough so that the angle with the ground does not exceed 15 degrees (Figure 42). On flat ground, this requires a ramp to be at least 4 times as long as the height of the trailer or truck bed to the ground. A steeper angle may cause mower components to get caught as the machine moves from the ramp to the trailer or truck. Steeper angles may also cause the machine to tip or lose control. If you are loading the machine on or near a slope, position the trailer or truck so that it is on the down side of the slope and the ramp extends up the slope. This minimizes the ramp angle.

⚠ WARNING

Loading a machine onto a trailer or truck increases the possibility of a tip-over and could cause serious injury or death.

- Use extreme caution when operating a machine on a ramp.
- Ensure that the ROPS is in the up position and use the seat belt when loading or unloading the machine. Ensure that the ROPS clears the top of an enclosed trailer.
- Use only a full-width ramp; do not use individual ramps for each side of the machine.
- Do not exceed a 15-degree angle between the ramp and the ground or between the ramp and the trailer or truck.
- Ensure that the length of ramp is at least 4 times as long as the height of the trailer or truck bed to the ground. This ensures that ramp angle does not exceed 15 degrees on flat ground.
- Back the machine up the ramp and drive it forward down the ramp.
- Avoid sudden acceleration or deceleration while driving the machine on a ramp as this could cause a loss of control or a tip-over.

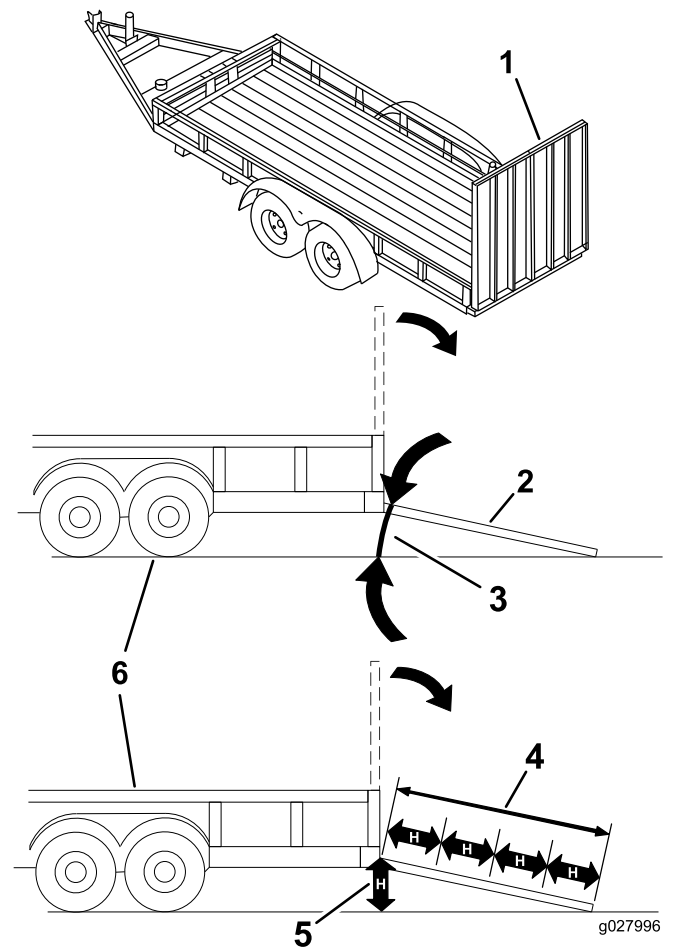

Figure 42

1. Full-width ramp in stowed position
2. Side view of full-width ramp in loading position
3. Not greater than 15 degrees
4. The ramp is at least 4 times as long as the height of the trailer or truck bed to the ground.
5. H= height of the trailer or truck bed to the ground
6. Trailer

Operating Tips

Using the Fast Throttle Setting

For best mowing and maximum air circulation, operate the engine at the FAST throttle position. Air is required to thoroughly cut grass clippings, so do not set the height of cut so low as to totally surround the mower in uncut grass. Always try to have 1 side of the mower free from uncut grass, which allows air to be drawn into the mower.

Cutting a Lawn for the First Time

Cut the grass slightly longer than normal to ensure that the cutting height of the mower does not scalp any uneven ground. However, the cutting height you have used in the past is generally the best to use. When cutting grass longer than 15 cm (6 inches) tall, you may want to cut the lawn twice to ensure an acceptable quality of cut.

Cutting a Third of the Grass Blade

It is best to cut only about a third of the grass blade. Cutting more than that is not recommended unless grass is sparse, or it is late fall when grass grows more slowly.

Alternating the Mowing Direction

Alternate the mowing direction to keep the grass standing straight. This also helps disperse clippings, which enhances decomposition and fertilization.

Mowing at Correct Intervals

Normally, mow every 4 days. However, grass grows at different rates at different times. To maintain the same cutting height, which is a good practice, mow more often in early spring. As the grass growth rate slows in mid-summer, mow less frequently. If you cannot mow for an extended period, first mow at a high cutting height; then mow again 2 days later at a lower height setting.

Adjusting the Cutting Speed

To improve cut quality, use a slower ground speed in certain conditions.

Avoiding Cutting Too Low

If the cutting width of the mower is wider than the mower that you previously used, raise the cutting height to ensure that uneven turf is not cut too short.

Cutting Long Grass

If the grass is ever allowed to grow slightly longer than normal, or if it contains a high degree of moisture, raise the cutting height higher than usual and cut the grass at this setting. Then cut the grass again using the lower, normal setting.

Stopping

If you must stop the forward motion of the machine while mowing, a clump of grass clippings may drop onto your lawn. To avoid this, move onto a previously cut area with the blades engaged.

Keeping the Underside of the Mower Clean

Clean clippings and dirt from the underside of the mower after each use. If grass and dirt build up inside the mower, the cutting quality eventually becomes unsatisfactory.

Maintaining the Blade

Maintain a sharp blade throughout the cutting season, because a sharp blade cuts cleanly without tearing or shredding the grass blades. Tearing and shredding turns grass brown at the edges, which slows growth and increases the chance of disease. Check the cutter blades daily for sharpness and for any wear or damage. File down any nicks and sharpen the blades as necessary. If a blade is damaged or worn, replace it immediately with a genuine Toro replacement blade.

Maintenance

Recommended Maintenance Schedule(s)

Maintenance Service Interval	Maintenance Procedure
After the first 100 hours	<ul style="list-style-type: none"> • Check the wheel lug-nut torque. • Check the wheel hub slotted-nut torque. • Check the parking-brake adjustment (check every time you remove or replace a brake component).
After the first 250 hours	<ul style="list-style-type: none"> • Change the hydraulic filters and hydraulic fluid.
Before each use or daily	<ul style="list-style-type: none"> • Check the safety system. • Check the engine-oil level. • Check the seat belt. • Check the rollover-protection-system (ROPS) knobs. • Clean the engine screen and the oil cooler. • Clean the hydraulic units. • Inspect the blades. • Clean the mower deck.
Every 50 hours	<ul style="list-style-type: none"> • Grease the mower-deck spindles and idler arm. • Check spark arrester (if equipped). • Check the tire pressure. • Inspect the belts for cracks and wear. • Check the hydraulic-fluid level.
Every 100 hours	<ul style="list-style-type: none"> • Lubricate the mower deck lift pivots. • Change the engine oil (more often in dirty or dusty conditions). • Check and clean the engine cooling fins and shrouds.
Every 150 hours	<ul style="list-style-type: none"> • Inspect the primary filter and air-inlet screen.
Every 200 hours	<ul style="list-style-type: none"> • Change the engine oil filter (more often in dirty or dusty conditions). • Clean the engine oil cooler. • Check, clean and gap the spark plug. • Replace the fuel filter (more often in dirty or dusty conditions).
Every 250 hours	<ul style="list-style-type: none"> • Change the hydraulic filters and hydraulic fluid when using Mobil® 1 fluid (more often in dirty or dusty conditions).
Every 300 hours	<ul style="list-style-type: none"> • Replace the primary air filter (more often in dusty or sandy conditions). • Check the inner air filter.
Every 500 hours	<ul style="list-style-type: none"> • Check the wheel lug-nut torque. • Check the wheel hub slotted-nut torque. • Adjust the caster-pivot bearing. • Check the parking-brake adjustment. • Change the hydraulic filters and hydraulic fluid when using Toro® HYPR-OIL™ 500 hydraulic fluid (more often in dirty or dusty conditions).
Every 600 hours	<ul style="list-style-type: none"> • Replace the inner air filter.
Monthly	<ul style="list-style-type: none"> • Check the battery.
Yearly	<ul style="list-style-type: none"> • Grease the pump-belt idler arm. • Grease the front caster pivots (more often in dirty or dusty conditions). • Repack the front caster-wheel bearings (more often in dirty or dusty conditions). • Lubricate the caster-wheel hubs.
Yearly or before storage	<ul style="list-style-type: none"> • Paint chipped surfaces. • Check all maintenance procedures listed above before storage.

Important: Refer to your engine operator's manual for additional maintenance procedures.

⚠ CAUTION

If you leave the key in the ignition switch, someone could accidentally start the engine and seriously injure you or other bystanders.

Remove the key from the ignition before you do any maintenance.

Lubrication

Grease more frequently when operating conditions are extremely dusty or sandy.

Grease Type: No. 2 lithium or molybdenum-base grease

1. Disengage the blade-control switch (PTO), move the motion-control levers to the NEUTRAL-LOCK position, and set the parking brake.
2. Shut off the engine, remove the key, and wait for all moving parts to stop before leaving the operating position.
3. Clean the grease fittings with a rag.

Note: Make sure to scrape any paint off the front of the fitting(s).

4. Connect a grease gun to the fitting and pump grease into the fittings until grease begins to ooze out of the bearings.
5. Wipe up any excess grease.

Adding Light Oil or Spray Lubrication

Service Interval: Every 100 hours

Lubricate the deck lift pivots.

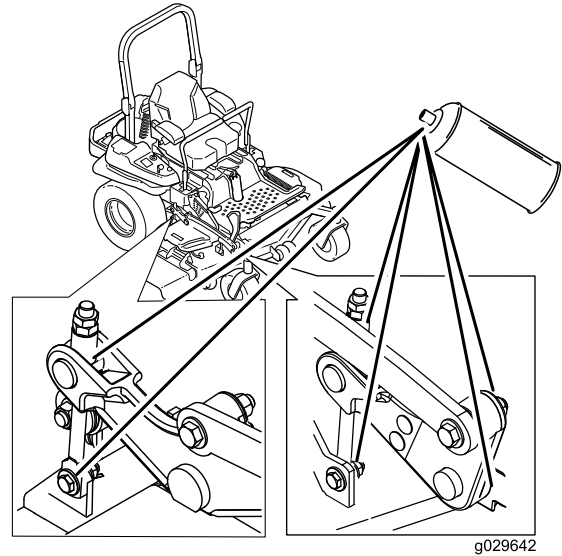

Figure 43

g029642

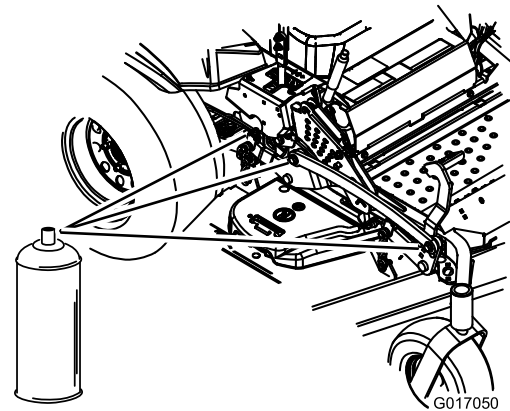

Figure 44

g017050

Greasing the Mower

Service Interval: Every 50 hours—Grease the mower-deck spindles and idler arm.

Yearly—Grease the pump-belt idler arm.

Yearly—Grease the front caster pivots (more often in dirty or dusty conditions).

Yearly—Repack the front caster-wheel bearings (more often in dirty or dusty conditions).

1. Disengage the blade-control switch (PTO), move the motion-control levers to the NEUTRAL-LOCK position, and set the parking brake.
2. Shut off the engine, remove the key, and wait for all moving parts to stop before leaving the operating position.
3. Grease the mower-deck idler-pulley pivot until grease come out the bottom ([Figure 45](#)).
4. Grease the 3 spindle bearings until grease comes out the lower seals ([Figure 45](#)).

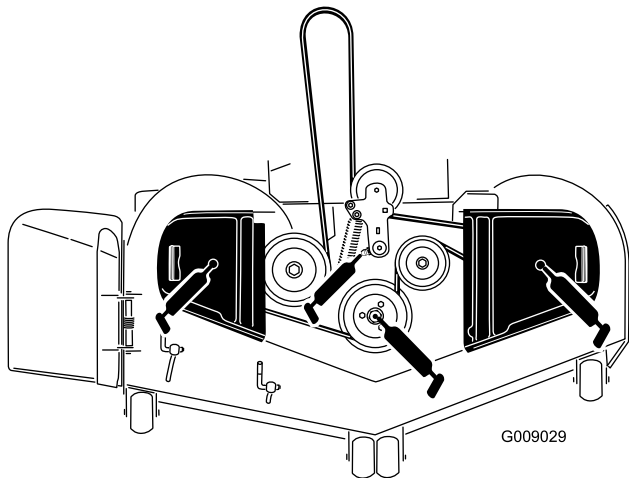

Figure 45

5. Grease the drive-belt idler arm ([Figure 46](#)).

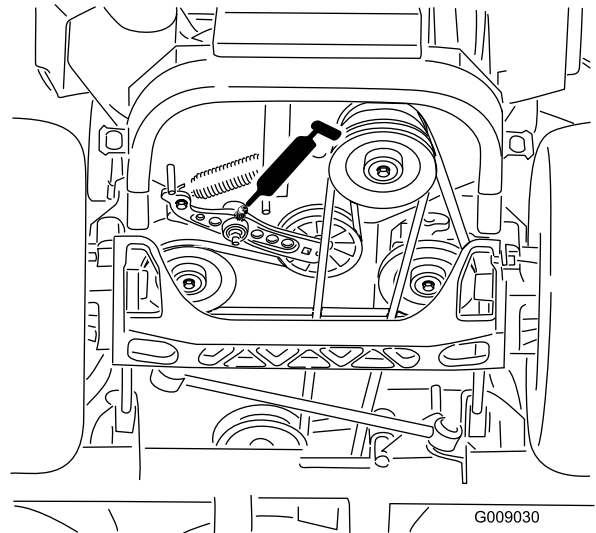

Figure 46

6. Remove the dust cap and adjust the caster pivots.

Note: Keep the dust cap off until greasing is complete. Refer to [Adjusting the Caster-Pivot Bearing](#) (page 52).

7. Remove the hex plug and thread a grease fitting into the hole.
8. Pump grease into the fitting until it oozes out around the top bearing.
9. Remove the grease fitting from the hole.
10. Install the hex plug and dust cap ([Figure 47](#)).

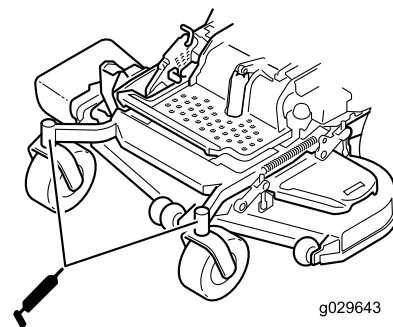

Figure 47

Lubricating the Caster-Wheel Hubs

Service Interval: Yearly

1. Shut off the engine, wait for all moving parts to stop, remove the key, and engage the parking brake.

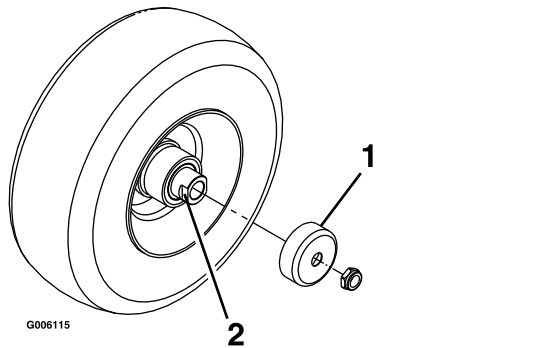

Figure 48

1. Seal guard
2. Spacer nut with wrench flats

2. Remove the caster wheel from the caster forks.
3. Remove the seal guards from the wheel hub.
4. Remove a spacer nut from the axle assembly in the caster wheel.

Note: Thread-locking compound has been applied to lock the spacer nuts to the axle.

5. Remove the axle (with the other spacer nut still assembled to it) from the wheel assembly.
6. Pry out seals and inspect bearings for wear or damage and replace if necessary.
7. Pack the bearings with a general-purpose grease.
8. Insert 1 bearing and 1 new seal into the wheel.

Note: Replace the seals.

9. If both spacer nuts have been removed (or broken loose) from the axle assembly, apply a thread-locking compound to 1 spacer nut and thread it onto the axle with the wrench flats facing outward.

Note: Do not thread the spacer nut all of the way onto the end of the axle. Leave approximately 3 mm (1/8 inch) from the outer surface of the spacer nut to the end of the axle inside the nut.

10. Insert the assembled nut and axle into the wheel on the side with the new seal and bearing.
11. With the open end of the wheel facing up, fill the area inside the wheel around the axle full of general-purpose grease.

12. Insert the second bearing and new seal into the wheel.
13. Apply a thread-locking compound to the second spacer nut and thread it onto the axle with the wrench flats facing outward.
14. Torque the nut to 8 to 9 N·m (75 to 80 in-lb), loosen the nut, then torque it to 2 to 3 N·m (20 to 25 in-lb).

Note: Make sure that the axle does not extend beyond either nut.

15. Install the seal guards over the wheel hub and insert wheel into the caster fork.
16. Install the caster bolt and tighten the nut fully.

Important: To prevent seal and bearing damage, check the bearing adjustment often. Spin the caster tire. The tire should not spin freely (more than 1 or 2 revolutions) or have any side play. If the wheel spins freely, adjust the torque on the spacer nut until there is a slight amount of drag. Apply another layer of thread-locking compound.

Engine Maintenance

⚠ WARNING

Contact with hot surfaces may cause personal injury.

Keep hands, feet, face, clothing, and other body parts away the muffler and other hot surfaces.

Servicing the Air Cleaner

Service Interval: Every 150 hours

Every 300 hours/Yearly (whichever comes first)—Replace the primary air filter (more often in dusty or sandy conditions).

Every 300 hours—Check the inner air filter.

Every 600 hours—Replace the inner air filter.

Note: Check the filters more frequently if the operating conditions are extremely dusty or sandy.

Removing the Filters

1. Disengage the blade-control switch (PTO), move the motion-control levers to the NEUTRAL-LOCK position, and set the parking brake.
2. Shut off the engine, remove the key, and wait for all moving parts to stop before leaving the operating position.
3. Release the latches on the air cleaner and pull the air-inlet cover off the air-cleaner body (Figure 49).
4. Clean the air-inlet screen and cover.
5. Install the air-inlet cover and secure it with the latches (Figure 49).

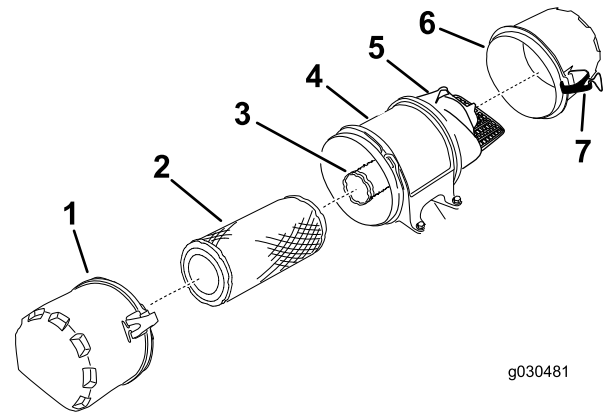

g030481

g030481

Figure 49

- | | |
|---------------------|---------------------|
| 1. Cover | 5. Air-inlet screen |
| 2. Primary filter | 6. Cover |
| 3. Inner filter | 7. Latch |
| 4. Air-cleaner body | |

6. Release the latches on the air cleaner and pull the air-cleaner cover off the air-cleaner body (Figure 49).
7. Clean the inside of the air-cleaner cover with compressed air.
8. Gently slide the primary filter out of the air-cleaner body (Figure 49).

Note: Avoid knocking the filter into the side of the body.

9. Remove the inner filter only if you intend to replace it.

Important: Never attempt to clean the inner filter. If the safety filter is dirty, then the primary filter is damaged; replace both filters.

10. Inspect the primary filter for damage by looking into the filter while shining a bright light on the outside of the filter.

Note: Any holes in the filter appear as bright spots. If the filter is damaged, discard it.

Servicing the Primary Filter

- If the primary filter is dirty, bent, or damaged, replace it.
- Do not clean the primary filter.

Servicing the Safety Filter

Replace the safety filter, never clean it.

Important: Never attempt to clean the safety filter. If the safety filter is dirty, then the primary filter is damaged. Replace both filters.

Installing the Filters

Important: To prevent engine damage, always operate the engine with both air filters and the cover installed.

1. If you are installing new filters, check each filter for shipping damage.

Note: Do not use a damaged filter.

2. If you are replacing the inner filter, carefully slide it into the filter body (Figure 49).
3. Carefully slide the primary filter over the inner filter (Figure 49).

Note: Ensure that the primary filter is fully seated by pushing on its outer rim while installing it.

Important: Do not press on the soft inside area of the filter.

4. Install the air-cleaner cover and secure the latches (Figure 49).

Servicing the Engine Oil

Oil Type: Detergent oil (API service class SL, SM, SN, or higher)

Oil Capacity: with a filter change, 1.9 L (2.0 US qt); with no filter change, 1.6 L (1.7 US qt)

Viscosity: See the table below.

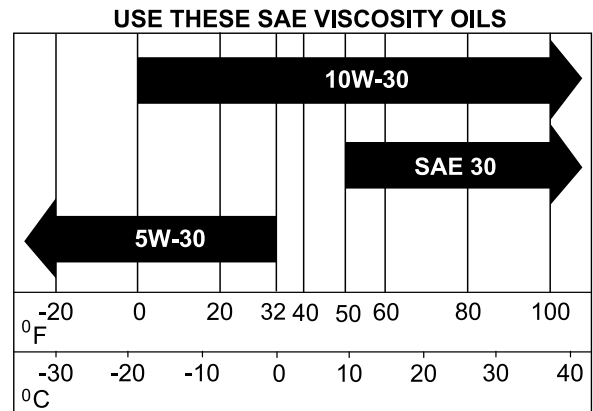

G032626
g032626

Figure 50

Note: Use of synthetic oil having 5W-20 or 5W-30 rating is acceptable, up to 4 degrees C (40 degrees F).

Note: Synthetic oils will provide better starting in extreme cold below -23 degrees C (-10 degrees F).

Checking the Engine-Oil Level

Service Interval: Before each use or daily

Note: Check the oil when the engine is cold.

⚠ WARNING

Contact with hot surfaces may cause personal injury.

Keep hands, feet, face, clothing and other body parts away from the muffler and other hot surfaces.

Important: Do not overfill the crankcase with oil because damage to the engine may result. Do not run engine with oil below the low mark because the engine may be damaged.

1. Disengage the blade-control switch (PTO), move the motion-control levers to the NEUTRAL-LOCK position, and set the parking brake.
2. Shut off the engine, remove the key, and wait for all moving parts to stop before leaving the operating position (Figure 51).

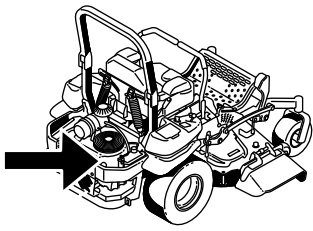

G029644
g029644

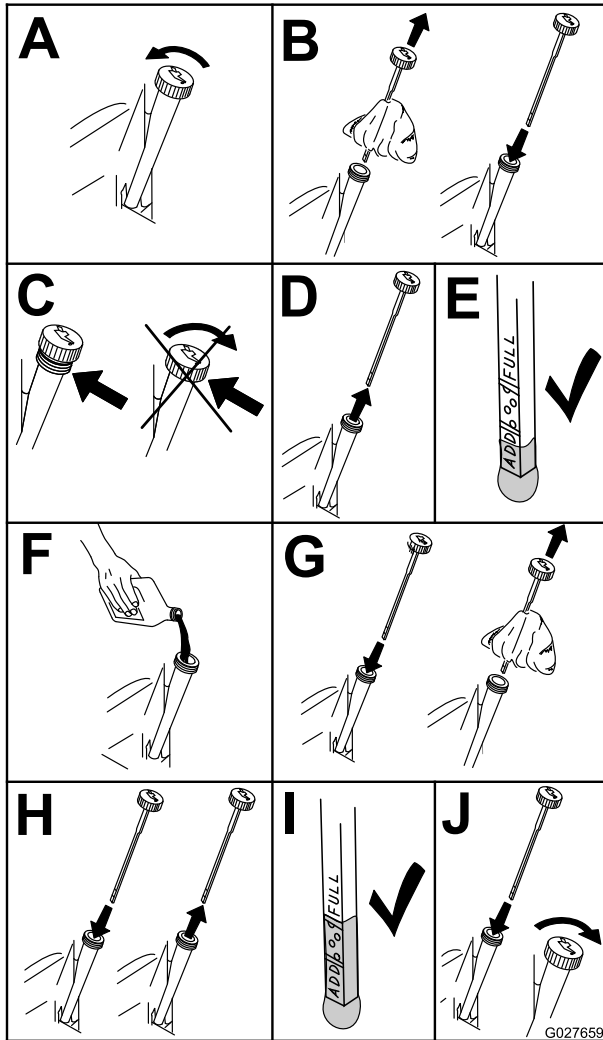

Figure 51

G027659
g027659

Changing the Engine Oil

Service Interval: Every 100 hours (more often in dirty or dusty conditions).

Note: Dispose of the used oil at a recycling center.

1. Start the engine and let it run for 5 minutes.
Note: This warms the oil so that it drains better.
2. Park the machine so that the rear is slightly lower than the front to ensure that the oil drains completely.
3. Disengage the blade-control switch (PTO), move the motion-control levers to the NEUTRAL-LOCK position, and set the parking brake.
4. Shut off the engine, remove the key, and wait for all moving parts to stop before leaving the operating position (Figure 52).

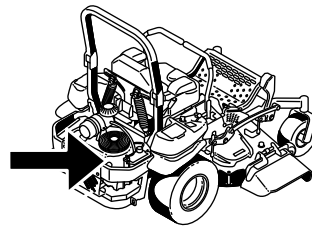

G029644
g029644

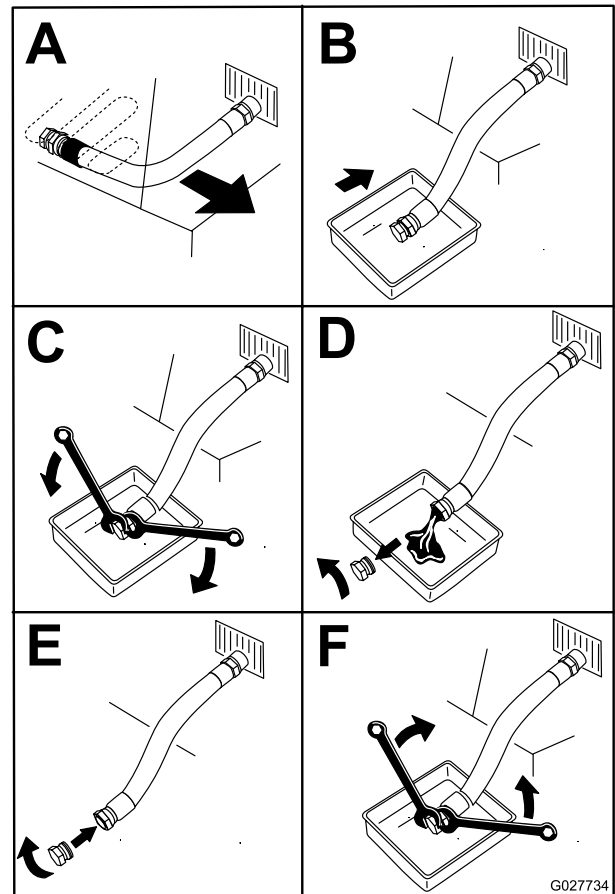

Figure 52

G027734
g027734

- Slowly pour approximately 80% of the specified oil into the filler tube and slowly add the additional oil to bring it to the **Full** mark (Figure 53).

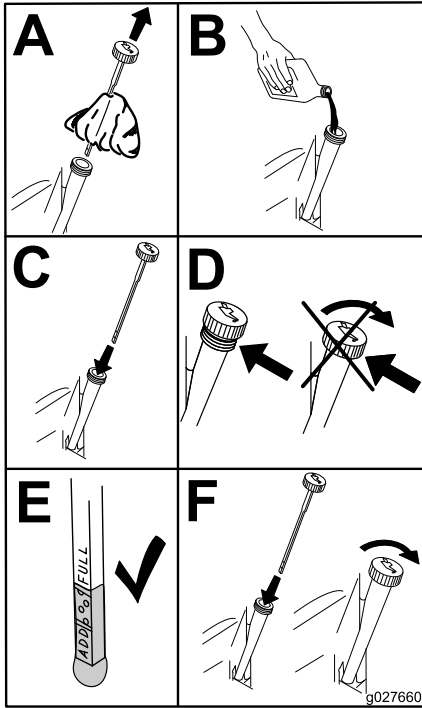

Figure 53

g027660

- Start the engine and drive to a flat area. Check the oil level again.

Changing the Engine-Oil Filter

Service Interval: Every 200 hours (more often in dirty or dusty conditions).

Note: Change the engine oil filter more frequently when operating conditions are extremely dusty or sandy.

- Drain the oil from the engine; refer to [Changing the Engine Oil \(page 42\)](#).
- Change the engine oil filter (Figure 54).

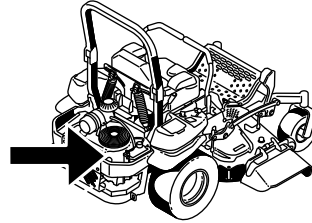

G029644
g029644

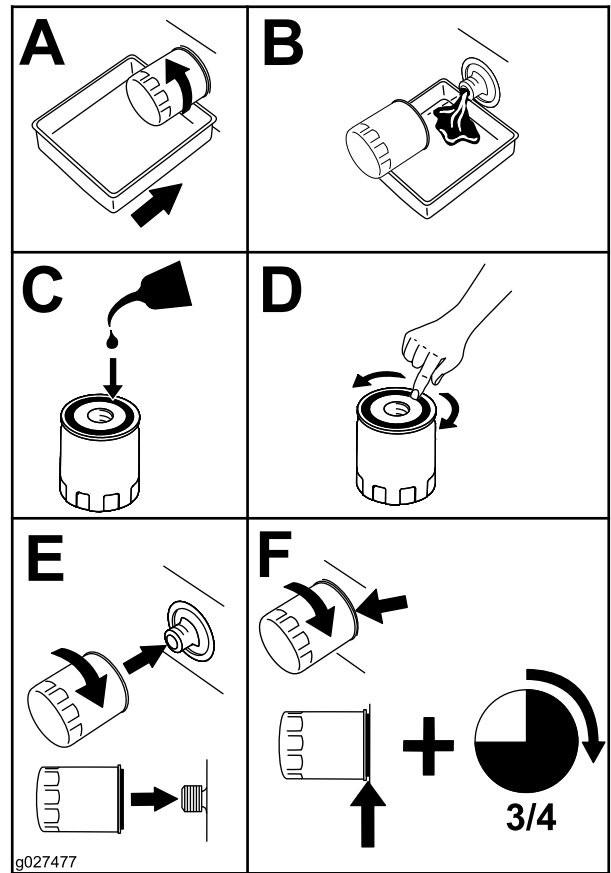

Figure 54

g027477

g027477

Note: Ensure the oil filter gasket touches the engine and then an extra 3/4 turn is completed.

- Fill the crankcase with the proper type of new oil; refer to [Changing the Engine Oil \(page 42\)](#).

Servicing the Engine-Oil Cooler

Service Interval: Every 200 hours

1. Keep the oil cooler free of debris by cleaning the fins with a brush.
2. Remove the bolts holding the oil cooler to the engine housing.
3. Clean the inside of the oil cooler with a brush.
4. Install the oil cooler to the engine housing.

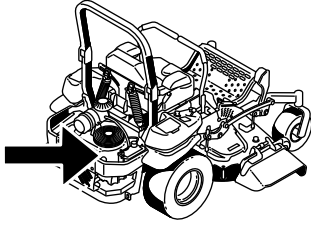

G029644
g029644

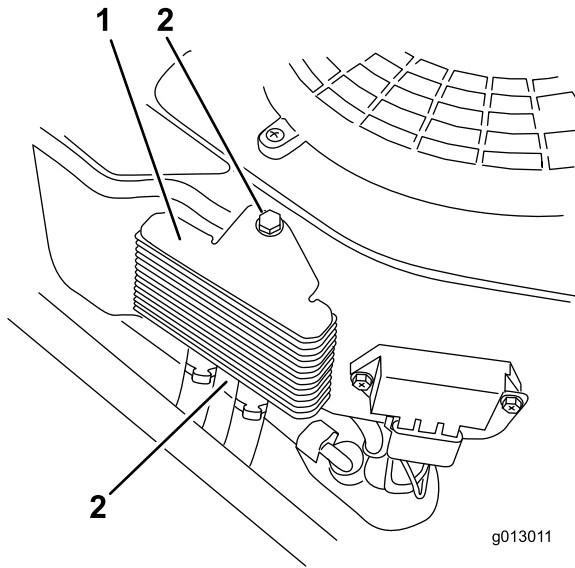

g013011

g013011

Figure 55

1. Engine-oil cooler
2. Bolts

Removing the Spark Plug

1. Shut off the engine, remove the key, and wait for all moving parts to stop before leaving the operating position.
2. Disengage the blade-control switch (PTO), move the motion-control levers to the NEUTRAL-LOCK position, and set the parking brake.
3. Remove the left hydraulic unit shroud in the order listed with [Figure 56](#).

Note: This gives you access to the front spark plug.

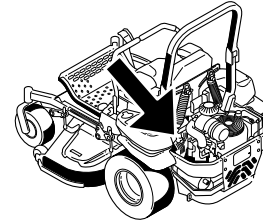

g029645

g029645

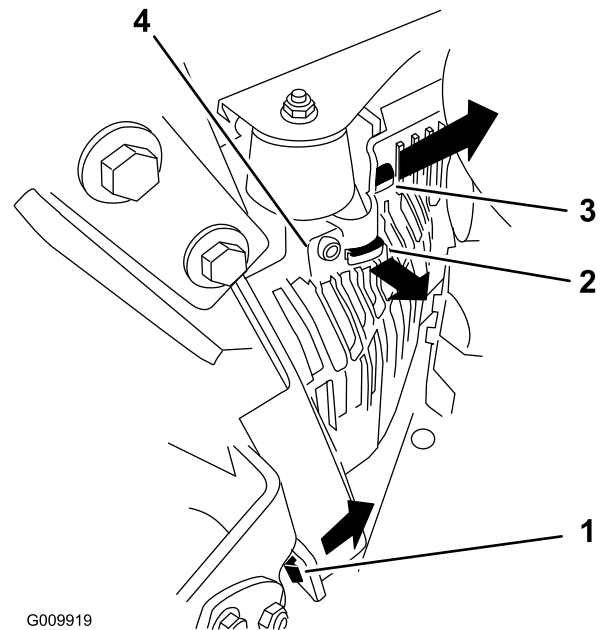

G009919

g009919

Figure 56

1. Pull this tab out to the side in the direction of the arrow.
2. Pull the shroud off this frame tab in the direction of the arrow.
3. Pull the shroud off this frame tab in the direction of the arrow.
4. Shroud

Servicing the Spark Plug

Service Interval: Every 200 hours—Check, clean and gap the spark plug.

Make sure that the air gap between the center and side electrodes is correct before installing the spark plug. Use a spark plug wrench to remove and install the spark plug(s) and use a gapping tool/feeler gauge to check and adjust the air gap. Install a new spark plug(s) if necessary.

Type : Champion® XC12YC, or equivalent

Air Gap: 0.76 mm (0.030 inch)

4. Remove the spark plug ([Figure 57](#)).

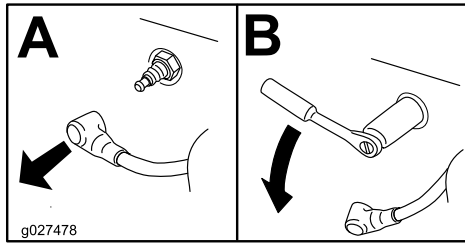
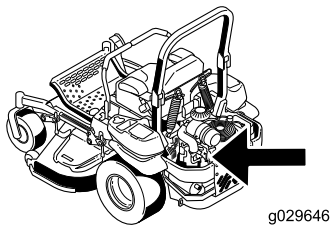

Figure 57

5. Install the left hydraulic unit shroud (Figure 56).

Checking the Spark Plug

Important: Replace the spark plug(s) when it has: a black coating, worn electrodes, an oily film, cracks or reuse is questionable.

If you see light brown or gray on the insulator, the engine is operating properly. A black coating on the insulator usually means the air cleaner is dirty.

Set the gap to 0.76 mm (0.030 inches).

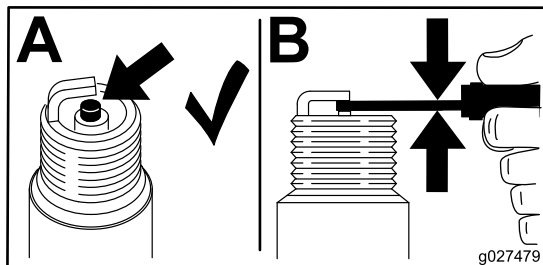

Figure 58

Installing the Spark Plug

Tighten the spark plug(s) to 24.4 to 29.8 N·m (18 to 22 ft-lb).

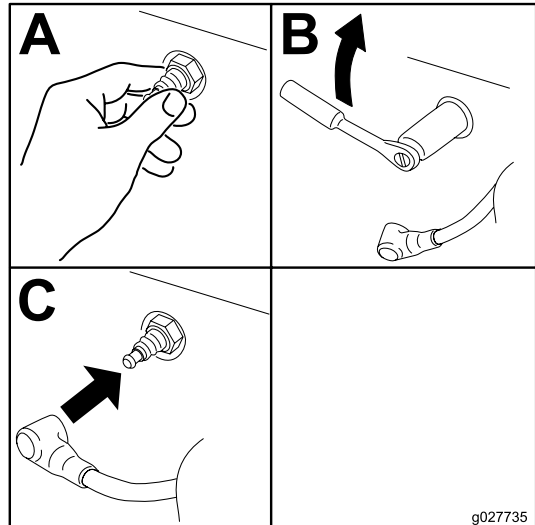

Figure 59

Checking the Spark Arrester (if Equipped)

Service Interval: Every 50 hours

⚠ WARNING

Hot exhaust system components may ignite gasoline vapors even after you shut off the engine. Hot particles exhausted during engine operation may ignite flammable materials. Fire may result in personal injury or property damage.

Do not refuel or run the engine unless a spark arrester is installed.

1. Shut off the engine, wait for all moving parts to stop, and remove key. Engage parking brake.
2. Wait for the muffler to cool.
3. If there are any breaks in the screen or welds, replace the arrester.
4. If the screen is plugged, remove the arrester and shake the loose particles out of the arrester and clean the screen with a wire brush (soak it in solvent if necessary). Install the arrester on the exhaust outlet.

Fuel System Maintenance

⚠ WARNING

Fuel-system components are under high pressure. The use of improper components can result in system failure, gasoline leakage, and possible explosion.

Use only approved fuel lines and fuel filters.

Servicing the Electronic Fuel-Injection System

This machine contains an electronic fuel-injection system. It controls the fuel flow under different operating conditions.

The electronic control unit (ECU) continuously monitors the operation of the EFI system.

If a problem or fault within the system is detected, the malfunction indicator light (MIL) illuminates. The MIL is the red light located in the right console panel.

Once the MIL illuminates, make initial troubleshooting checks. Refer to the MIL section under [Troubleshooting \(page 73\)](#).

If these checks do not correct the problem, further diagnosis and servicing by an Authorized Service Dealer is necessary.

Replacing the Low-Pressure Fuel Filter

Service Interval: Every 200 hours/Yearly (whichever comes first)

The fuel filter is located near the engine on the front or rear side of the engine.

1. Disengage the blade-control switch (PTO), move the motion-control levers to the NEUTRAL-LOCK position, and set the parking brake.
2. Shut off the engine, remove the key, and wait for all moving parts to stop before leaving the operating position.
3. Wait for the machine to cool down.
4. Close the fuel-shutoff valve under the seat ([Figure 60](#)).

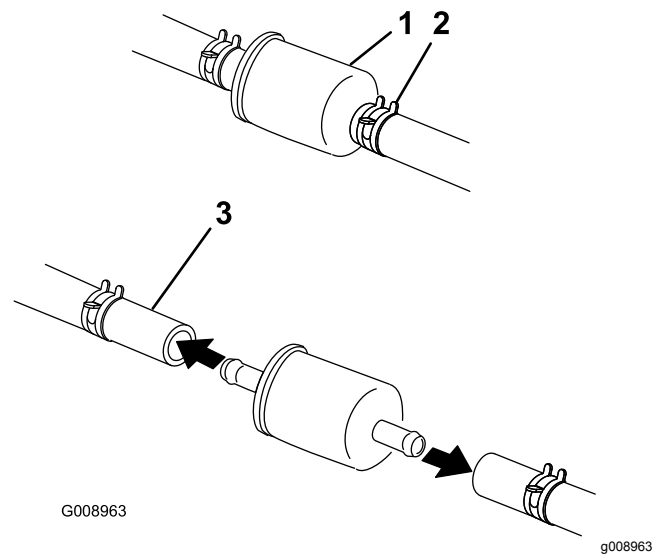

Figure 60

1. Fuel filter
2. Hose clamp
3. Fuel line

5. Squeeze the ends of the hose clamps together and slide them away from the filter ([Figure 60](#)).
6. Remove the filter from the fuel lines.
7. Install a new filter and move the hose clamps close to the filter ([Figure 60](#)).
8. Open the fuel-shutoff valve.

Important: Install the fuel line hoses and secure with plastic ties the same as they were originally installed at the factory to keep the fuel line away from components that can cause fuel line damage.

Servicing the High-Pressure Fuel Filter

Do not attempt to service the high-pressure fuel filter. The high-pressure filter is integrated within the fuel-pump module. The fuel filter and other components inside the fuel-pump module are not serviceable.

Important: Do not attempt to open the fuel-pump module.

Ensure that an Authorized Service Dealer replaces the fuel-pump module with the high-pressure fuel filter.

Servicing the Fuel Tank

Do not attempt to drain the fuel tank. Ensure that an Authorized Service Dealer drains the fuel tank.

Electrical System Maintenance

Servicing the Battery

Service Interval: Monthly

⚠ DANGER

Battery electrolyte contains sulfuric acid, which is a deadly poison and causes severe burns.

Do not drink electrolyte and avoid contact with skin, eyes, or clothing. Wear safety glasses to shield your eyes and wear rubber gloves to protect your hands.

Removing the Battery

⚠ WARNING

Battery terminals or metal tools could short against metal machine components, causing sparks. Sparks can cause the battery gasses to explode, resulting in personal injury.

- When removing or installing the battery, do not allow the battery terminals to touch any metal parts of the machine.
- Do not allow metal tools to short between the battery terminals and metal parts of the machine.

⚠ WARNING

Incorrect battery cable routing could damage the machine and cables, causing sparks. Sparks can cause the battery gasses to explode, resulting in personal injury.

- Always disconnect the negative (black) battery cable before disconnecting the positive (red) cable.
 - Always connect the positive (red) battery cable before connecting the negative (black) cable.
1. Disengage the blade-control switch (PTO), move the motion-control levers to the NEUTRAL-LOCK position, and set the parking brake.
 2. Shut off the engine, remove the key, and wait for all moving parts to stop before leaving the operating position.

3. Disconnect the negative battery cable (black) from the negative (-) battery terminal (Figure 61).
4. Slide the red terminal boot off the positive (+) battery terminal and remove the positive (red) battery cable (Figure 61).
5. Remove the wing nut securing the battery clamp (Figure 61).
6. Remove the clamp (Figure 61).
7. Remove the battery (Figure 61).

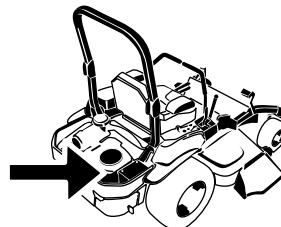

G008804
g008804

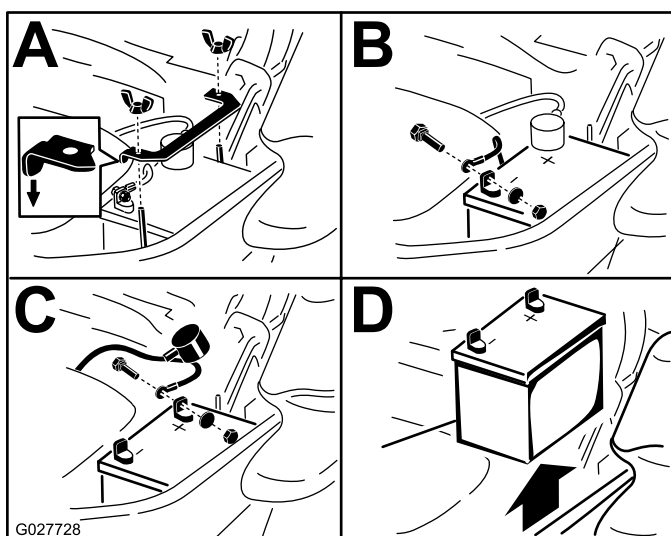

Figure 61

Installing the Battery

1. Position battery in the tray with the terminal posts opposite from the hydraulic tank (Figure 61).
2. Install the positive (red) battery cable to the positive (+) battery terminal.
3. Install the negative (black) battery cable and ground wire to the negative (-) battery terminal.
4. Secure the cables with 2 bolts, 2 washers, and 2 locknuts (Figure 61).
5. Slide the red terminal boot onto the positive (+) battery terminal.
6. Install the clamp and secure it with the wing nut (Figure 61).

Charging the Battery

⚠ WARNING

Charging the battery produces gasses that can explode.

Never smoke near the battery and keep sparks and flames away from battery.

Important: Always keep the battery fully charged (1.265 specific gravity). This is especially important to prevent battery damage when the temperature is below 0°C (32°F).

1. Charge battery for 10 to 15 minutes at 25 to 30 A or for 30 minutes at 10 A.
2. When the battery is fully charged, unplug the charger from the electrical outlet, then disconnect the charger leads from the battery posts (Figure 62).
3. Install the battery in the machine and connect the battery cables; refer to [Installing the Battery](#) (page 47).

Note: Do not run the machine with the battery disconnected; otherwise, electrical damage may occur.

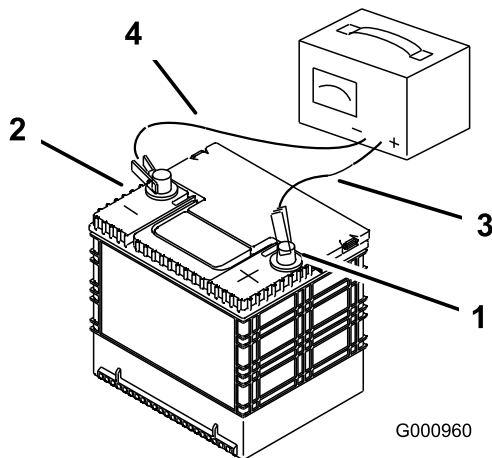

Figure 62

1. Positive battery post
2. Negative battery post
3. Red (+) charger lead
4. Black (-) charger lead

Servicing the Fuses

The electrical system is protected by fuses. It requires no maintenance, however, if a fuse blows check the component and circuit for a malfunction or short.

1. The fuses are located on right console next to the seat (Figure 63).
2. To replace the fuses, pull out the fuse to remove it.
3. Install a new fuse (Figure 63).

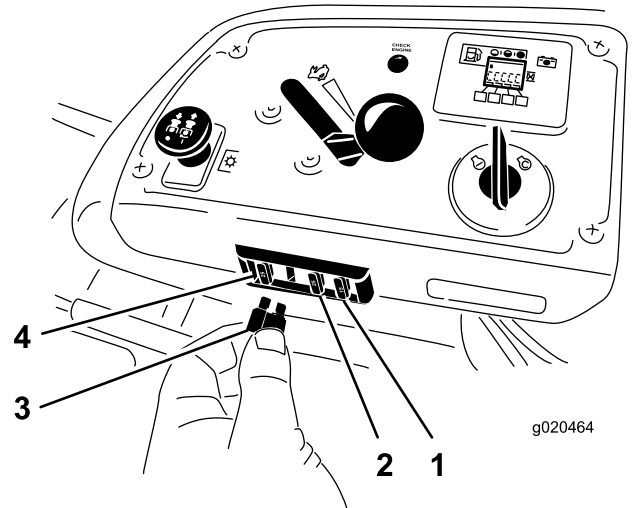

Figure 63

1. Optional accessory (15 A)
2. Charge (25 A)
3. PTO (10 A)
4. Main (25 A)
5. Console

Jump-Starting the Machine

1. Check and clean corrosion from the battery terminals before jump-starting. Ensure that the connections are tight.

⚠ CAUTION

Corrosion or loose connections can cause unwanted electrical voltage spikes at any time during the jump-starting procedure.

Do not attempt to jump-start the machine with loose or corroded battery terminals, or damage to the engine or EFI may occur.

⚠ DANGER

Jump-starting a weak battery that is cracked, frozen, or has a low electrolyte level or an open/shorted battery cell can cause an explosion, resulting in serious personal injury.

Do not jump-start a weak battery if these conditions exist.

2. Make sure that the booster battery is a good and fully charged lead-acid battery at 12.6 V or greater.

Note: Use properly sized jumper cables with short lengths to reduce voltage drop between systems. Make sure that the cables are color coded or labeled for the correct polarity.

⚠ CAUTION

Connecting the jumper cables incorrectly (wrong polarity) can immediately damage the EFI system.

Be certain of battery terminal polarity and jumper cable polarity when connecting the batteries.

⚠ WARNING

Batteries contain acid and produce explosive gases.

- Shield the eyes and face from the batteries at all times.
- Do not lean over the batteries.

Note: Be sure that the vent caps are tight and level. Place a damp cloth, if available, over any vent caps on both batteries. Be sure that the vehicles do not touch and that both electrical systems are off and at the same rated system voltage. These instructions are for negative ground systems only.

3. Connect the positive (+) cable to the positive (+) terminal of the discharged battery that is wired to the starter or solenoid as shown in [Figure 64](#).

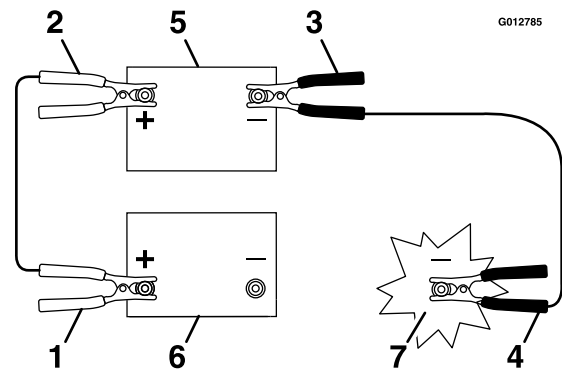

Figure 64

1. Positive (+) cable on discharged battery
2. Positive (+) cable on booster battery
3. Negative (-) cable on the booster battery
4. Negative (-) cable on the engine block
5. Booster battery
6. Discharged battery
7. Engine block

4. Connect the other end of the positive cable to the positive terminal of the booster battery.
5. Connect the black negative (-) cable to the other terminal (negative) of the booster battery.
6. Make the final connection on the engine block of the stalled vehicle (not to the negative battery post) **away from the battery and stand back** ([Figure 65](#)).

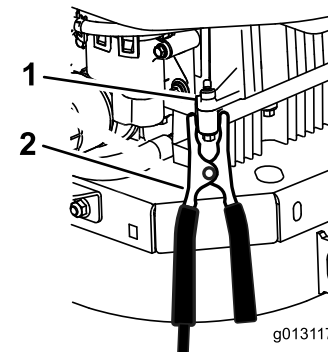
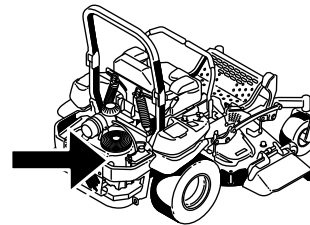

Figure 65

1. Engine block
2. Negative (-) cable

7. Start the vehicle and remove the cables in the reverse order of connection..

Note: Disconnect the engine block (black) first.

Drive System Maintenance

Checking the Seat Belt

Service Interval: Before each use or daily

Inspect the seat belt for wear, cuts, and proper operation of the retractor and buckle. Replace the seat belt if it is damaged.

Checking the Rollover-Protection-System (ROPS) Knobs

Service Interval: Before each use or daily

⚠ WARNING

To avoid injury or death from rollover: keep the roll bar in the fully raised locked position and use the seat belt.

Ensure that the seat is secured to the machine.

Check that both the mounting hardware and the knobs are in good working condition. Make sure that the knobs are fully engaged with the ROPS in the raised position. The upper hoop of the roll bar may need to be pushed forward or pulled rearward to fully engage both knobs ([Figure 66](#)).

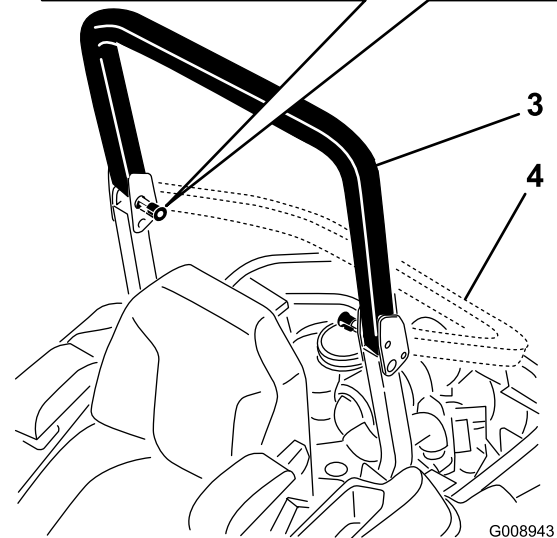
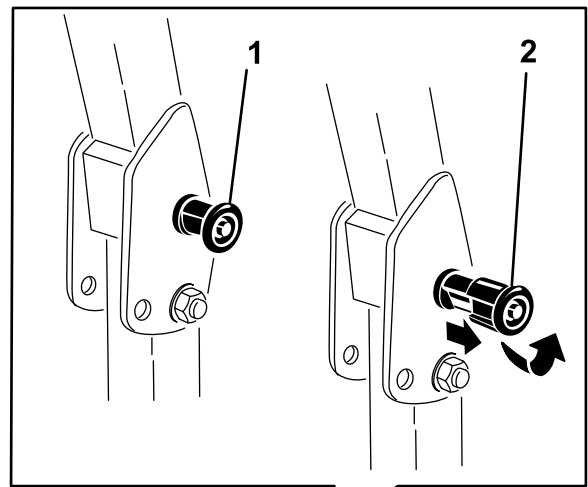

Figure 66

1. ROPS knob (locked position)
2. Pull the ROPS knob out, and rotate it 90 degrees to change the roll bar position.
3. Roll bar in the upright position
4. Roll bar in the folded position

Adjusting the Tracking

1. Disengage the blade-control switch (PTO).
2. Drive to an open, flat area and move the motion-control levers to the NEUTRAL-LOCK position.
3. Move the throttle midway between the FAST and SLOW positions.
4. Move both motion-control levers forward until they both hit the stops in the T-slot.
5. Check which way the machine tracks.
6. If the machine tracks to the right, loosen the bolts and adjust the left stop plate rearward on the left T-slot until the machine tracks straight (Figure 67).
7. If the machine tracks to the left, loosen the bolts and adjust the right stop plate rearward on the right T-slot until the machine tracks straight (Figure 67).
8. Tighten the stop plate (Figure 67).

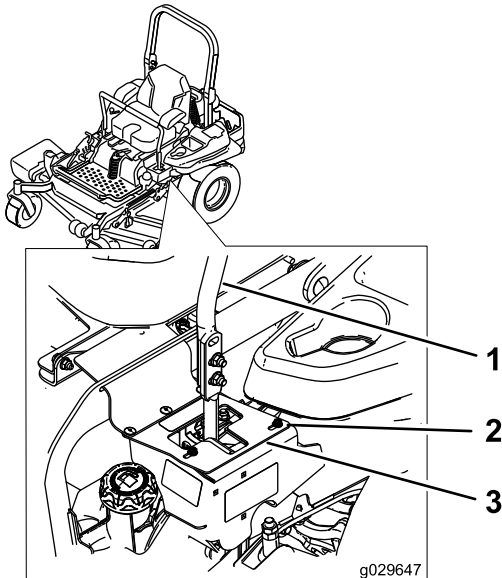

Figure 67

Left control lever shown

1. Control lever
2. Bolt
3. Stop plate

Checking the Tire Pressure

Service Interval: Every 50 hours/Monthly (whichever comes first)

Maintain the air pressure in the rear tires at 90 kPa (13 psi). Uneven tire pressure can cause uneven cut. Check the tires when they are cold, to get the most accurate pressure reading.

Note: The front tires are semi-pneumatic tires and do not require air-pressure maintenance.

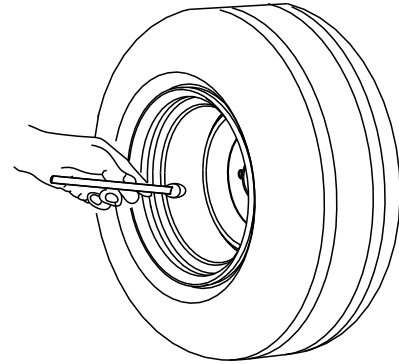

Figure 68

g001055

Checking the Wheel Lug Nuts

Check and torque the wheel lug nuts to 122 to 129 N·m (90 to 95 ft-lb).

Checking the Wheel Hub Slotted Nut

Service Interval: After the first 100 hours
Every 500 hours

Check and ensure that the torque of the slotted nut is 286 to 352 N·m (211 to 260 ft-lb).

Note: Do not use anti-seize compound on the wheel hub.

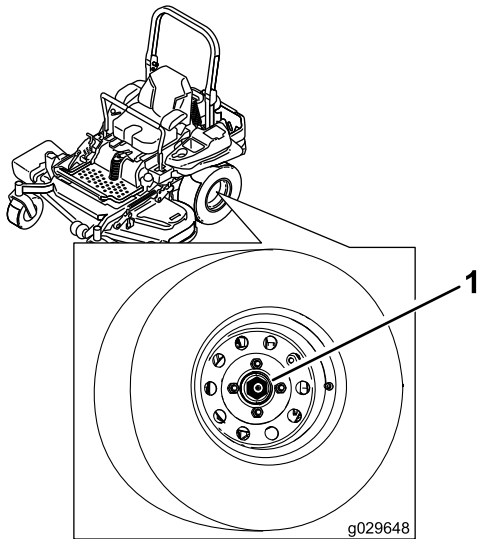

Figure 69

1. Slotted nut

Adjusting the Caster-Pivot Bearing

Service Interval: Every 500 hours/Yearly (whichever comes first)

1. Disengage the blade-control switch (PTO), move the motion-control levers to the NEUTRAL-LOCK position, and set the parking brake.
2. Shut off the engine, remove the key, and wait for all moving parts to stop before leaving the operating position.
3. Remove the dust cap from caster and tighten the locknut (Figure 70).
4. Tighten the locknut until the spring washers are flat, and then back off a 1/4 turn to properly set the preload on the bearings (Figure 70).

Important: Make sure that the spring washers are installed correctly as shown in Figure 70.

5. Install the dust cap (Figure 70).

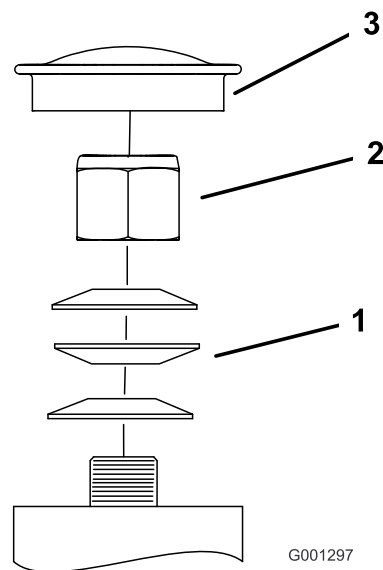

Figure 70

1. Spring washers
2. Locknut
3. Dust cap

Using the Clutch Shim

Some later model year units have been built with clutches that contain a brake shim. When the clutch brake has worn to the point where the clutch no longer engages consistently, you can remove the shim to extend the clutch life.

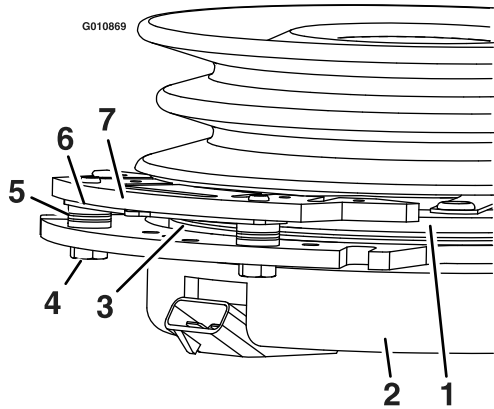

Figure 71

g010869

- | | |
|------------------------|-----------------|
| 1. Armature | 5. Brake spacer |
| 2. Field shell | 6. Regap shim |
| 3. Rotor | 7. Brake pole |
| 4. Brake-mounting bolt | |

Removing the Clutch Shim

1. Shut off the engine, wait for all moving parts to stop, and remove the key.
2. Engage the parking brake and wait for machine to cool completely.
3. Using an air compressor, blow out any debris under the brake pole and around the brake spacers.

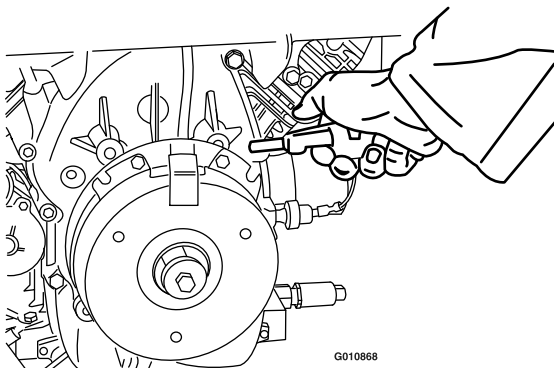

Figure 72

g010868

4. Check the condition of the wire-harness leads, connectors, and terminals. Clean or repair them as necessary.

5. Verify that 12 V is present at the clutch connector when you engage the blade-control switch (PTO).
6. Measure the gap between the rotor and armature. If the gap is greater than 1 mm (0.04 inch), proceed with the following steps:
 - A. Loosen both brake mounting bolts 1/2 to 1 full turn as shown in Figure 73.

Note: Do not remove the brake pole from the field shell/armature. The brake pole has worn to match the armature and needs to continue to match after you remove the shim to ensure the proper brake torque.

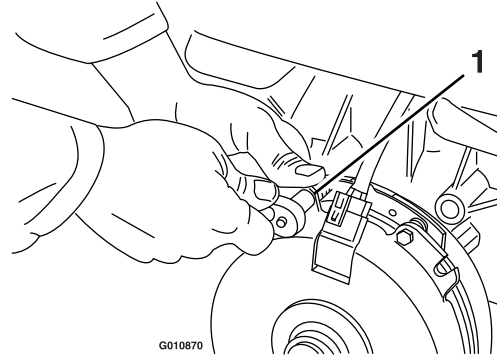

Figure 73

g010870

1. Brake-mounting bolt

- B. Using needle-nose pliers, or by hand, remove the shim.

Note: Do not discard the shim until you confirm that the clutch functions properly.

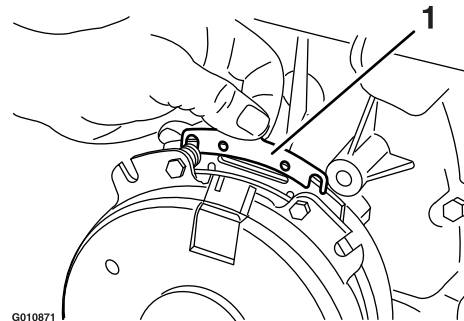

Figure 74

g010871

1. Shim

- C. Using a pneumatic line, blow out any debris under the brake pole and around the brake spacers.
- D. Torque each bolt (M6 x 1) to 12.3 to 13.7 N·m (9.5 to 10.5 ft-lb).

- E. Using a 0.010 inch thick-feeler gauge, verify that a gap is present between the rotor and armature face on both sides of the brake pole as shown in [Figure 75](#) and [Figure 76](#).

Note: Due to the way the rotor and armature faces wear (peaks and valleys), it is sometimes difficult to measure the true gap.

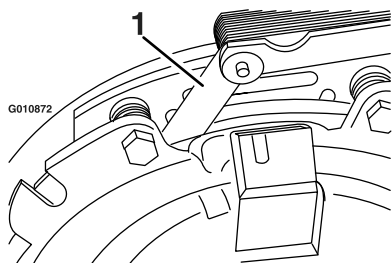

Figure 75

g010872

1. Feeler gauge
-

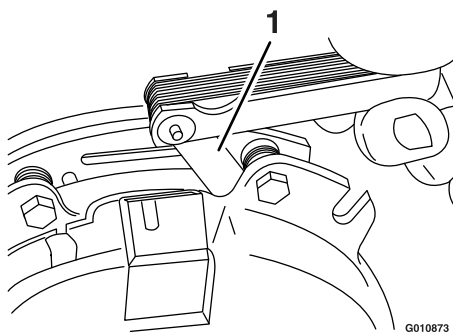

Figure 76

g010873

1. Feeler gauge
-

- If the gap is less than 0.010 inch, then install the shim and refer to [Troubleshooting \(page 73\)](#).
- If the gap is sufficient, proceed to the safety check in step [F](#).

- F. Perform the following safety check:
- i. Sit on the seat and start the engine.
 - ii. Make sure that the blades do not engage when the blade-control switch (PTO) is in the OFF position and the clutch is disengaged.

Note: If the clutch does not disengage, install the shim, and refer to [Troubleshooting \(page 73\)](#).

- iii. Engage and disengage the blade-control switch (PTO) 10 consecutive times to ensure that the clutch is functioning properly.

Note: If the clutch does not engage properly, refer to [Troubleshooting \(page 73\)](#).

Cooling System Maintenance

Cleaning the Engine Screen and Engine-Oil Cooler

Service Interval: Before each use or daily

Remove any buildup of grass, dirt, or other debris from the oil cooler (Figure 77). This helps ensure adequate cooling, correct engine speed, and reduces the possibility of overheating and mechanical damage to the engine.

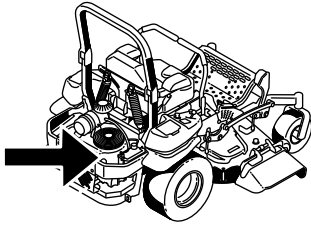

G029644
g029644

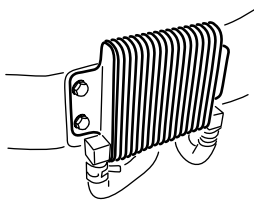

G009191

g009191

Figure 77

Cleaning the Engine Cooling Fins and Shrouds

Service Interval: Every 100 hours/Yearly (whichever comes first)

1. Disengage the blade-control switch (PTO) and set the parking brake.
2. Shut off the engine, remove the key, and wait for all moving parts to stop before leaving the operating position.
3. Remove the air intake screen, recoil starter, and fan housing (Figure 78).
4. Clean the debris and grass from the engine parts.
5. Install the air-intake screen, recoil starter, and fan housing (Figure 78).

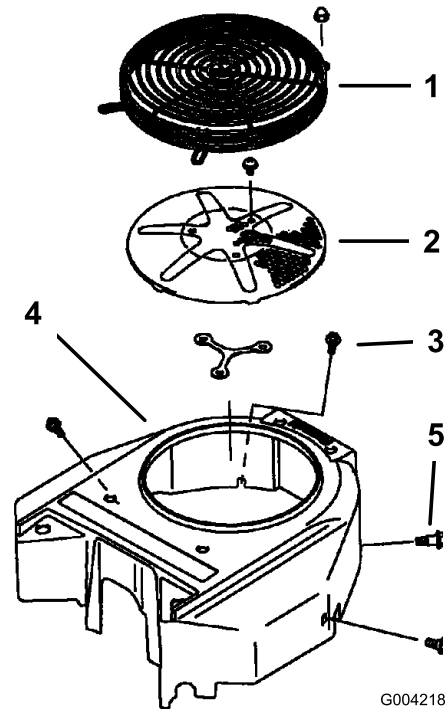

G004218

g004218

Figure 78

- | | |
|-----------------------------|----------------|
| 1. Engine guard | 4. Fan housing |
| 2. Engine air-intake screen | 5. Screw |
| 3. Bolt | |

Cleaning the Hydraulic Units

Service Interval: Before each use or daily

1. Disengage the blade-control switch (PTO) and set the parking brake.
2. Shut off the engine, remove the key, and wait for all moving parts to stop before leaving the operating position.
3. Move the seat forward.
4. Clean the debris and grass from the hydraulic units ([Figure 79](#)).
5. Position the seat.

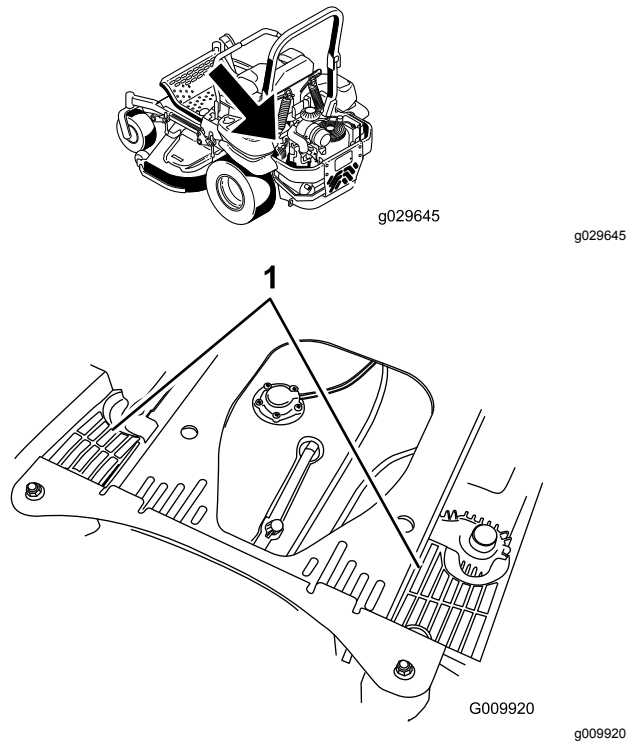

Figure 79

1. Hydraulic units

Brake Maintenance

Adjusting the Parking Brake

Service Interval: After the first 100 hours

Every 500 hours thereafter

1. Drive the machine onto a level surface.
2. Disengage the blade-control switch (PTO), move the motion-control levers to the NEUTRAL-LOCK position, and engage the parking brake.
3. Shut off the engine, wait for all moving parts to stop, and remove the key.
4. Raise the back of the machine and support the machine with jack stands.

▲ DANGER

Mechanical or hydraulic jacks may fail to support machine and cause a serious injury.

- Use a jack stand when supporting the machine.
 - Do not use hydraulic jacks.
5. Remove the rear tires from the machine.
 6. Remove any debris from the brake area.
 7. Rotate the drive-wheel release handle to the released position. Refer to [Using the Drive-Wheel Release Valves \(page 31\)](#).
 8. Check if there is a visible gap between the L-bracket and the linkage stop ([Figure 80](#)).

Belt Maintenance

Inspecting the Belts

Service Interval: Every 50 hours

Replace the belt if it is worn. The signs of a worn belt include squealing while the belt is rotating; the blades slipping while cutting grass; and frayed edges, burn marks, and cracks on the belt.

Replacing the Mower Belt

1. Disengage the blade-control switch (PTO), move the motion-control levers to the NEUTRAL-LOCK position, and set the parking brake.
2. Shut off the engine, remove the key, and wait for all moving parts to stop before leaving the operating position.
3. Lower the mower to the 76 mm (3 inch) height-of-cut.
4. Remove the belt covers (Figure 81).

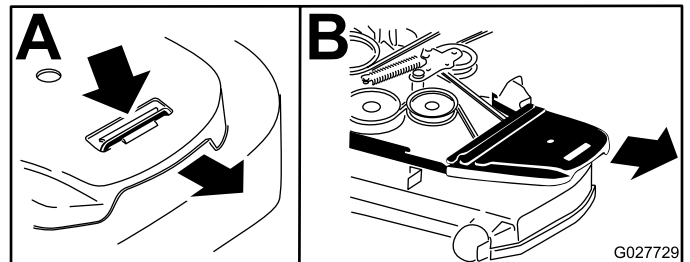

Figure 81

5. Use a ratchet in the square hole in the idler arm to remove tension on the idler spring (Figure 82).
6. Remove the belt from the mower-deck pulleys.
7. Remove the belt guide on the spring-loaded idler arm (Figure 82).
8. Remove the existing belt.
9. Install the new belt around the mower pulleys and the clutch pulley under the engine (Figure 82).

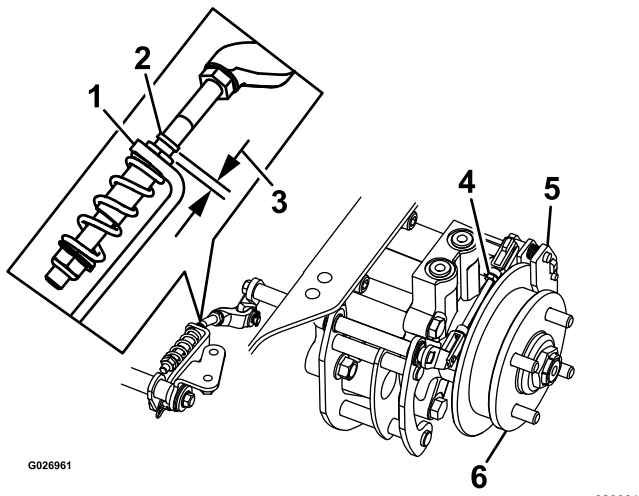

Figure 80
Left Side Shown

- | | |
|-----------------|--------------------------|
| 1. L-bracket | 4. Rear-linkage assembly |
| 2. Linkage stop | 5. Caliper |
| 3. Gap | 6. Wheel hub |

9. Disengage the parking brake.
10. Turn the wheel hub by hand in both directions relative to the caliper.
Note: The wheel hub should move freely between the caliper.
11. If a gap is needed or the wheel hub does not move freely:
 - A. Disengage the parking brake.
 - B. Disconnect and fine-tune the rear linkage assembly:
 - Shorten the link to create a gap.
 - Lengthen the link to allow wheel hub movement.
 - C. Connect the rear-linkage assembly.
12. Engage the parking brake and check the gap.
13. Repeat steps 9 through 13 until you achieve a visible gap and the wheel hub rotates freely.
14. Repeat this procedure for the brake on the opposite side.
15. Rotate the drive-wheel release handle to the operating position; refer to [Using the Drive-Wheel Release Valves \(page 31\)](#).
16. Install the rear tires and torque the lug nuts; refer to [Checking the Wheel Lug Nuts \(page 51\)](#).
17. Remove the jack stands.

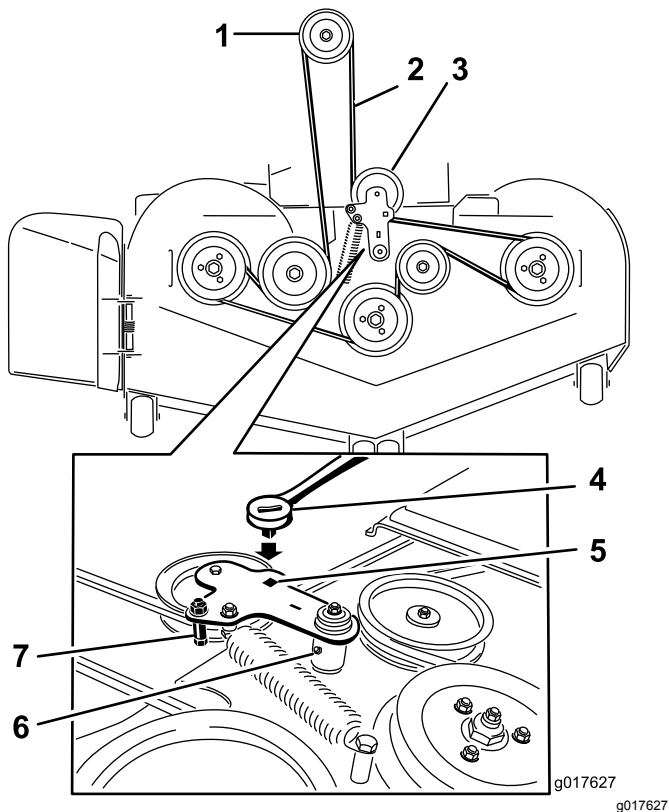

Figure 82

- | | |
|-------------------------------|---|
| 1. Clutch pulley | 5. Square hole in the idler arm for the ratchet |
| 2. Mower belt | 6. Idler-grease fitting |
| 3. Spring-loaded idler pulley | 7. Belt guide |
| 4. Ratchet | |

10. Install the belt guide on the idler arm (Figure 82).
11. Using the ratchet in the square hole, install the idler spring (Figure 82).

Note: Make sure to seat the spring ends in the anchor grooves.

12. Install the belt covers (Figure 83).

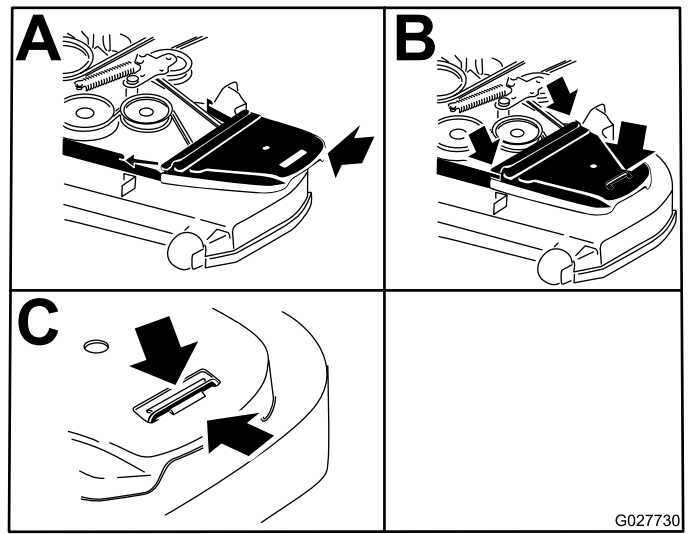

Figure 83

Replacing the Hydraulic-Pump Drive Belt

1. Disengage the blade-control switch (PTO) and set the parking brake.
2. Shut off the engine, remove the key, and wait for all moving parts to stop before leaving the operating position.
3. Remove mower belt; refer to [Replacing the Mower Belt \(page 57\)](#).
4. Raise the machine and support it with jack stands (Figure 84).

Controls System Maintenance

Adjusting the Control-Handle Position

There are 2 height positions for the control levers—high and low. Remove the bolts to adjust the height.

1. Disengage the blade-control switch (PTO), move the motion-control levers to the NEUTRAL-LOCK position, and set the parking brake.
2. Shut off the engine, remove the key, and wait for all moving parts to stop before leaving the operating position.
3. Loosen the bolts and flange nuts installed in the levers ([Figure 85](#)).
4. Align the levers in the front-to-rear position by bringing the levers together to the NEUTRAL position, slide them until they are aligned, and tighten the bolts ([Figure 85](#)).

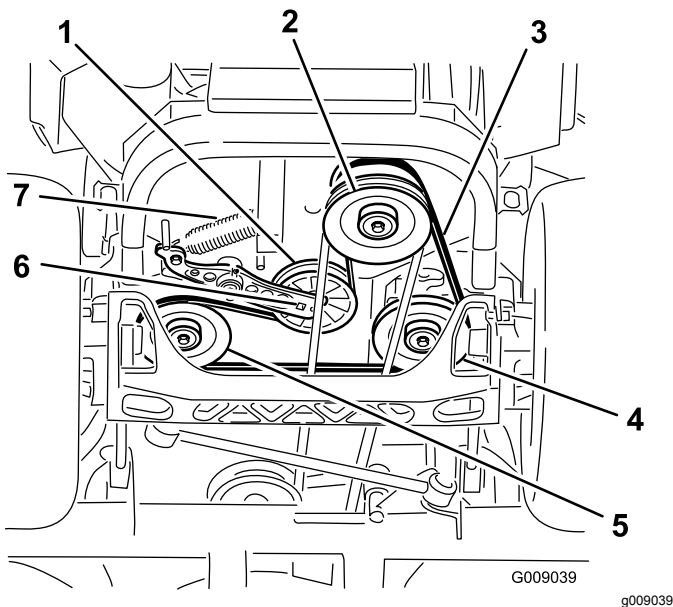

Figure 84

- | | |
|--------------------------------|-------------------------------|
| 1. Idler pulley | 5. Left hydraulic-pump pulley |
| 2. Clutch pulley | 6. Square hole in idler arm |
| 3. Pump-drive belt | 7. Idler spring |
| 4. Right hydraulic-pump pulley | |

5. Use a ratchet in the square hole in the idler arm to remove the idler spring ([Figure 84](#)).
6. Unhook the idler spring from the frame ([Figure 84](#)).
7. Remove the belt from the hydraulic-unit-drive pulleys and the engine pulley.
8. Install the new belt around engine pulley and the 2 drive pulleys.
9. Using a ratchet in the square hole in the idler arm, install the idler spring to the frame ([Figure 84](#)).
10. Install the mower belt; refer to [Replacing the Mower Belt \(page 57\)](#).

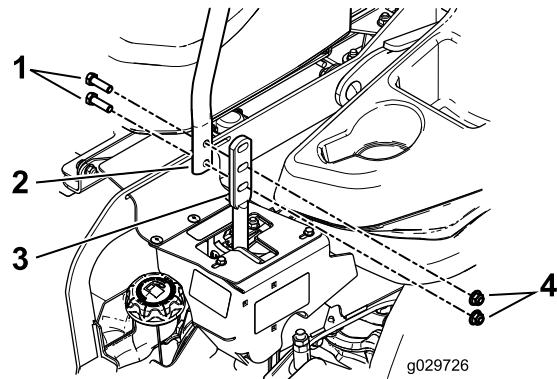

Figure 85

- | | |
|-----------|------------------|
| 1. Bolt | 3. Control lever |
| 2. Handle | 4. Nut |

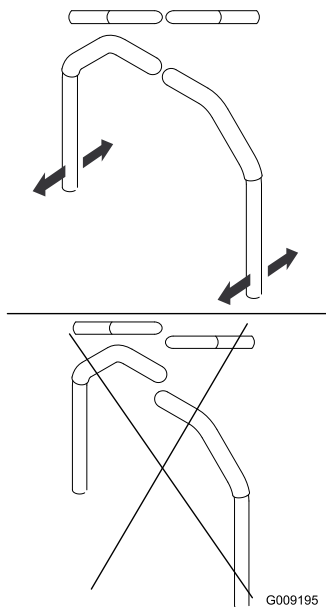

Figure 86

Note: The switch is a part of the seat assembly.

4. **Temporarily** install a jumper wire across the terminals in the connector of the main wiring harness.

5. If the ends of the levers hit against each other, refer to [Adjusting the Motion-Control Neutral-Lock Pivot](#) (page 62).

Adjusting the Motion-Control Linkage

The pump-control linkages are located on either side of the fuel tank, below the seat. Rotate the pump linkage with a 1/2 inch wrench for fine-tuning adjustments so that the machine does not move in neutral. Make any adjustments for neutral positioning only.

⚠ WARNING

The engine must be running and the drive wheels must be turning, so the motion-control adjustment can be performed. Contact with moving parts or hot surfaces may cause personal injury.

Keep your fingers, hands, and clothing clear of rotating components and hot surfaces.

1. Prior to starting the engine, push the deck-lift pedal, remove the height-of-cut pin, and lower the deck to the ground.
2. Raise the rear of machine and support it with jack stands (or equivalent support) just high enough to allow the drive wheels to turn freely.
3. Remove the electrical connection from the seat safety switch, located under the bottom cushion of the seat.

5. Start the engine.

Note: Engage the parking brake and move the motion-control levers out before starting the engine. You do not need to be in the seat because of the jumper wire being used. Run the engine at full throttle and release the brake.

6. Run the machine at least 5 minutes with the motion-control levers at full forward speed to bring the hydraulic fluid up to operating temperature.
7. Bring the motion-control levers into the NEUTRAL position.
8. Adjust the pump-control rod lengths by rotating the double nuts on the rod in the appropriate direction until the wheels slightly creep in reverse (Figure 87).

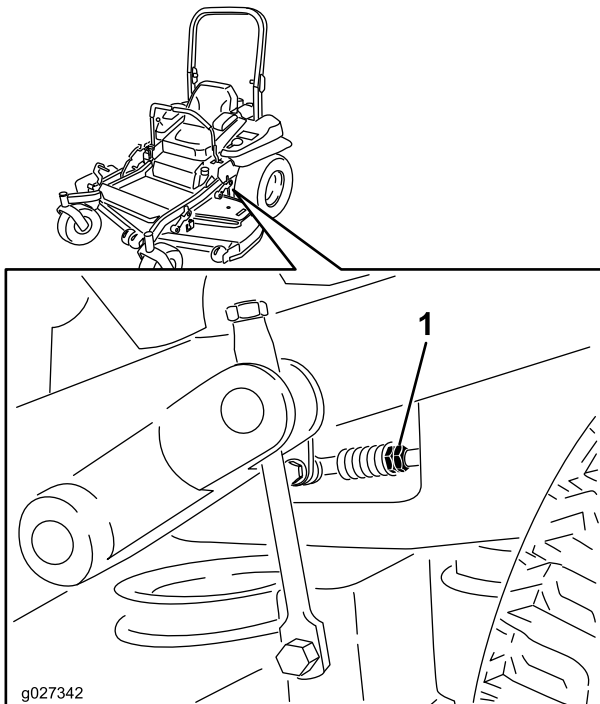

Figure 87

1. Double nuts

9. Move the motion-control levers to the REVERSE position, and while applying slight pressure to the lever, allow the reverse indicator springs to bring the levers back to neutral.

Note: The wheels must stop turning or slightly creep in reverse.

10. Shut off the machine.
11. Remove the jumper wire from wire harness and plug the connector into the seat switch.
12. Remove the jack stands.
13. Raise the deck and install the height-of-cut pin.

14. Check that the machine does not creep in neutral when you disengage the parking brakes.

Adjusting the Motion-Control Damper

You can adjust the top damper mounting bolt to obtain a more desired motion-control lever resistance. See Figure 88 for mounting options.

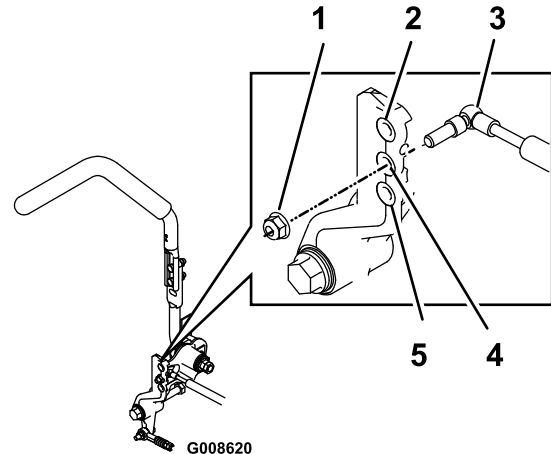

Figure 88

Right motion-control lever shown

1. Torque the locknut to 23 N·m (17 ft-lb). The bolt must protrude past the end of the locknut after torquing.
2. Most resistance (firmest feel)
3. Damper
4. Medium resistance (medium feel)
5. Least resistance (softest feel)

Adjusting the Motion-Control Neutral-Lock Pivot

You can adjust the flanged nut to obtain the desired motion-control lever resistance when you move them to the NEUTRAL-LOCK position. See [Figure 89](#) for adjustment options.

1. Loosen the jam nut.
2. Tighten or loosen the flanged nut to the desired feel.

Note: For more resistance, tighten the flanged nut.

Note: For less resistance, loosen the flanged nut

3. Tighten the jam nut.

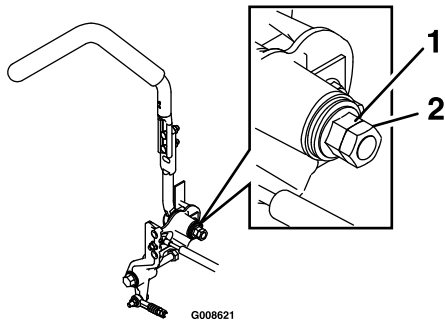

Figure 89

1. Flanged nut

2. Jam nut

Hydraulic System Maintenance

Servicing the Hydraulic System

Hydraulic Fluid Type: Toro® HYPR-OIL™ 500 hydraulic fluid or Mobil® 1 15W-50.

Important: Use the fluid specified. Other fluids could damage the hydraulic system.

Each Hydraulic System Fluid Capacity: 1.5 L (52 oz) per side with filter change

Checking the Hydraulic Fluid

Service Interval: Every 50 hours—Check the hydraulic-fluid level.

1. Position the machine on a level surface.
2. Disengage the blade-control switch (PTO), move the motion-control levers to the NEUTRAL-LOCK position, and set the parking brake.
3. Shut off the engine, remove the key, and wait for all moving parts to stop before leaving the operating position.
4. Wait for the engine and hydraulic system to cool for 10 minutes.

Note: The fluid level on the dipstick is incorrect if you check the fluid when the machine is hot.

5. Move the seat forward.
6. Clean the area around the dipsticks of the hydraulic system reservoirs ([Figure 90](#)).
7. Remove 1 dipstick from the hydraulic reservoir ([Figure 90](#)).
8. Wipe the dipstick off and thread the dipstick into the reservoir.
9. Remove the dipstick and look at the end ([Figure 90](#)).

Note: If the fluid level is at the add mark, slowly pour only enough fluid into the hydraulic reservoir to raise the level to the full or H line.

Important: Do not overfill the hydraulic units with fluid, as damage may occur. Do not run the machine with the fluid below the add mark.

10. Install the dipstick.
11. Repeat procedure for the opposite dipstick.

Replacing the Hydraulic Filters and Hydraulic Fluid

Service Interval: After the first 250 hours—Change the hydraulic filters and hydraulic fluid.

Every 250 hours—Change the hydraulic filters and hydraulic fluid when using Mobil® 1 fluid (more often in dirty or dusty conditions).

Every 500 hours—Change the hydraulic filters and hydraulic fluid when using Toro® HYPR-OIL™ 500 hydraulic fluid (more often in dirty or dusty conditions).

To replace the hydraulic fluid, you need to remove the filters. Replace both at the same time; refer to [Servicing the Hydraulic System \(page 62\)](#) for the oil specifications.

1. Disengage the blade-control switch (PTO), move the motion-control levers to the NEUTRAL-LOCK position, and set the parking brake.
2. Shut off the engine, remove the key, and wait for all moving parts to stop before leaving the operating position.
3. Raise the machine and support it with jack stands ([Figure 91](#)).

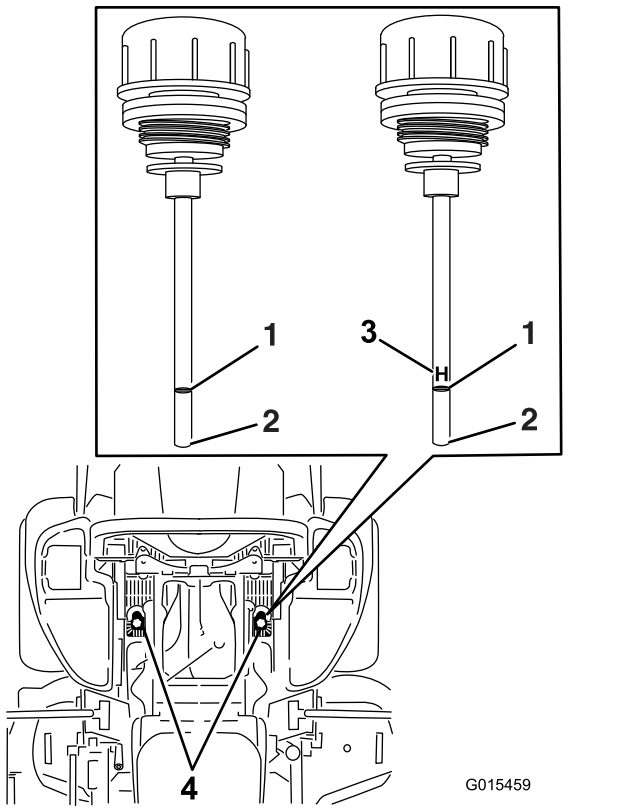

Figure 90

Either dipstick is used in the machine

- | | |
|---------|----------------------------------|
| 1. Full | 3. H—means high level |
| 2. Add | 4. Dipstick locations under seat |

⚠ WARNING

Hydraulic fluid escaping under pressure can penetrate skin and cause injury.

- If hydraulic fluid is injected into the skin, it must be surgically removed within a few hours by a doctor familiar with this type of injury. Gangrene may result if this is not done.
- Keep your body and hands away from pin hole leaks or nozzles that eject high-pressure hydraulic fluid.
- Use cardboard or paper to find hydraulic leaks.
- Safely relieve all pressure in the hydraulic system before performing any work on the hydraulic system.
- Make sure that all hydraulic-fluid hoses and lines are in good condition and that all hydraulic connections and fittings are tight before applying pressure to the hydraulic system.

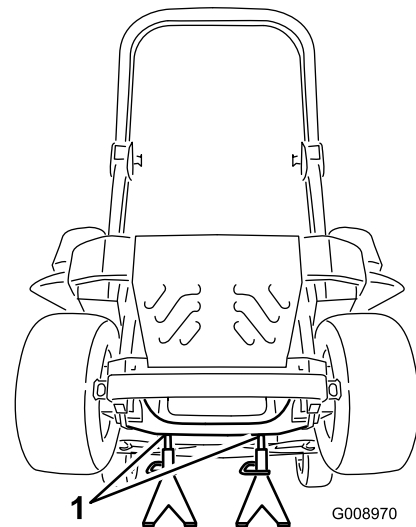

Figure 91

1. Jack stands

4. Remove both the mower belt and the pump-drive belt; refer to [Replacing the Mower Belt \(page 57\)](#) and [Replacing the Hydraulic-Pump Drive Belt \(page 58\)](#).

Note: This prevents oil from getting on the belts.

5. Place a drain pan under the filter, remove the old filter, and wipe the surface clean ([Figure 92](#)).

Mower Deck Maintenance

Leveling the Mower Deck

Setting Up the Machine

Note: Ensure that the mower deck is level before matching the height of cut (HOC).

1. Position the mower on a flat surface.
2. Disengage the blade-control switch (PTO), move the motion-control levers to the NEUTRAL-LOCK position, and set the parking brake.
3. Shut off the engine, remove the key, and wait for all moving parts to stop before leaving the operating position.
4. Check the pressure of the drive tires.

Note: Proper inflation pressure for the tires is 90 kPa (13 psi).

5. Position the mower deck to the 76 mm (3 inch) height-of-cut position.

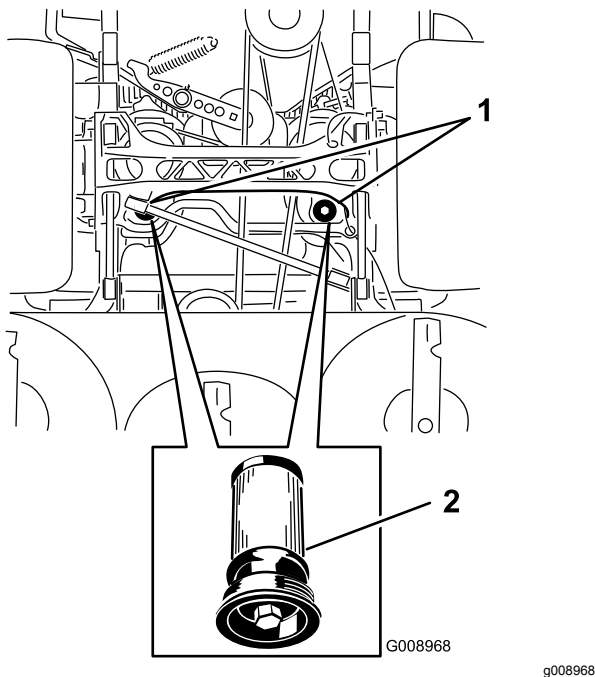

Figure 92

Bottom view of the machine

1. Filter locations
2. Hydraulic filter

6. Apply a thin coat of hydraulic fluid to the rubber gasket on the replacement filter (Figure 92).
7. Install the replacement hydraulic filter.
8. Install the pump-drive belt and the mower belt.
9. Remove the jack stands and lower the machine (Figure 91).
10. Add fluid to the hydraulic reservoir and check for any leaks.
11. Clean up any spilled fluid.
12. Start the engine and let it run for about 2 minutes to purge air from the system.
13. Shut off the engine and check for leaks.
14. Check the fluid level while the oil is cold.
15. If required, add fluid to the hydraulic reservoir.

Note: Do not overfill.

Leveling the Deck

1. Position the mower on a flat surface.
2. Shut off the engine, wait for all moving parts to stop, remove the key, and engage the parking brake.
3. Check the pressure in the drive tires.

Note: Proper inflation pressure for the tires is 90 kPa (13 psi).

4. Position the transport lock in the latching position.
5. Push the deck lift pedal all the way forward and the deck will latch at the 14 cm (5-1/2 inch) transport position (Figure 93).

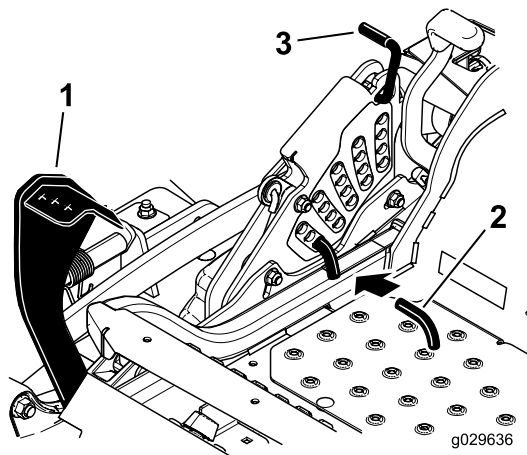

Figure 93

- 1. Deck-lift pedal
- 2. Height-of-cut pin
- 3. Transport lock

6. Insert the height-adjustment pin into the 7.6 cm (3 inch) height-of-cut location.
7. Release the transport lock and allow the deck to lower to the cutting height.
8. Raise the discharge chute.
9. On both sides of the deck, measure from the level surface to the front tip of the blade (Position A) as shown in Figure 94.

Note: The measurement should read 7.6 mm (3 inches)

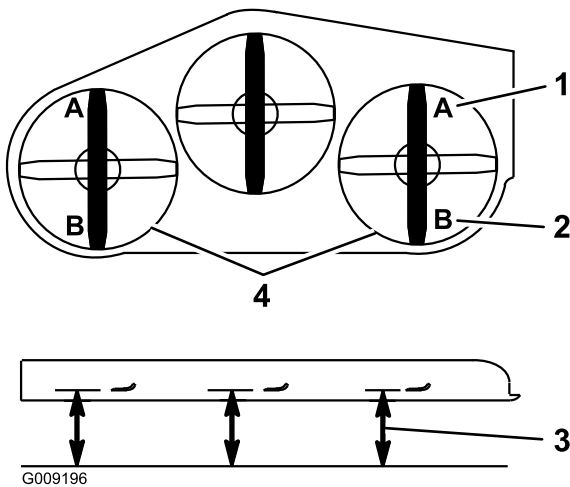

Figure 94

- 1. 7.6 cm (3 inches) at position A is correct.
- 2. 8.3 cm (3-1/4 inches) at position B is correct.
- 3. Measure here from the blade tip to the hard surface.
- 4. Measure at position A and B on both sides.

10. If needed, loosen the flanged locknut on the side of the yoke and the jam nut on top.

11. Fine-tune the adjuster screw by turning it to get 7.6 mm (3 inch) height (Figure 95).

Note: To increase the height, turn the adjuster screw clockwise; to decrease the height, turn it counterclockwise.

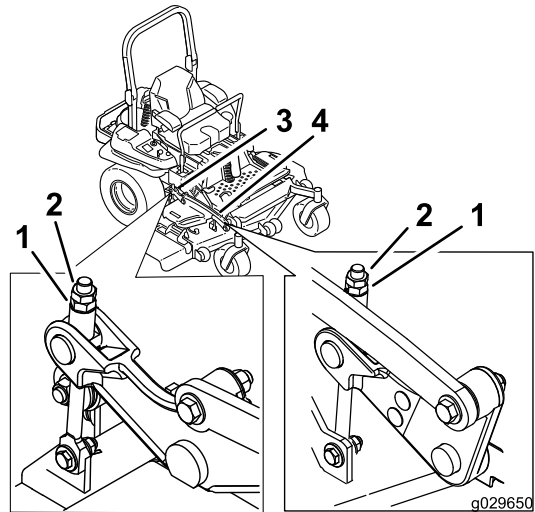

Figure 95

- 1. Flanged locknut
- 2. Adjuster screw
- 3. Jam nut
- 4. Yoke

12. If the front deck links do not have enough adjustment to achieve accurate cut height, loosen the 2 bolts at the bottom of the height-of-cut plate to adjust the single-point system (Figure 96).

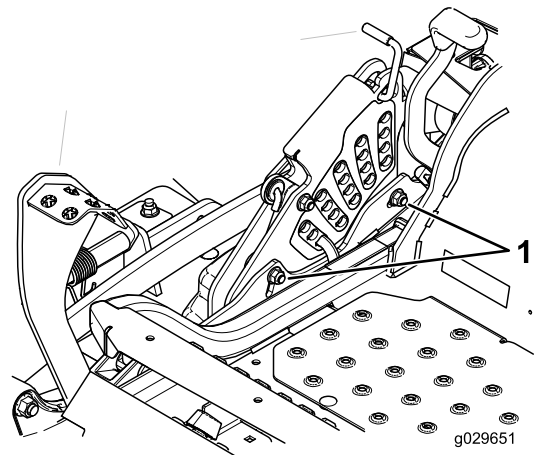

Figure 96

- 1. Bolts at the bottom of the height-of-cut plate

13. If the deck is too low, tighten the single-point adjustment bolt by rotating it clockwise. If the deck is too high, loosen the single-point adjustment bolt by rotating it counterclockwise (Figure 97).

Note: Loosen or tighten the single-point adjustment bolt enough to move the height-of-cut plate mounting bolts at least 1/3 the length of the available travel in their slots. This regains some up-and-down adjustment on each of the 4 deck links.

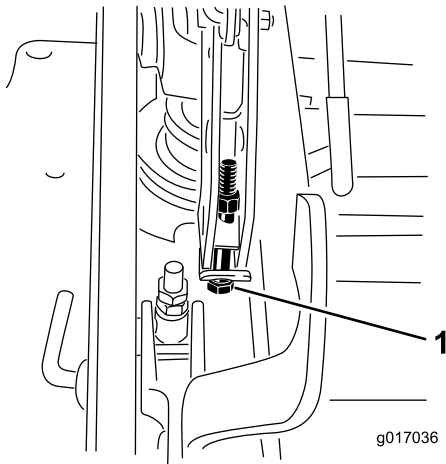

Figure 97

g017036

1. Single-point adjustment bolt

14. Tighten the 2 bolts at the bottom of the height-of-cut plate (Figure 96).
15. Torque the 2 bolts to 37 to 45 N·m (27 to 33 ft-lb).
16. On both sides of the deck, measure from the level surface to the back tip of the blade (position B) as shown in Figure 94.

Note: For most conditions, adjust the back blade tip 4 mm (1/4 inch) higher than the front.

Note: The measurement should read 8.3 cm (3-1/4 inches)

17. Fine-tune the adjuster screw by turning it to get 8.3 mm (3-1/4 inches) height (Figure 95).

Note: To increase the height, turn the adjustment nut clockwise; to decrease the height, turn it counterclockwise.

18. Measure until all 4 sides are the correct height.
19. Tighten all the nuts on the deck-lift-arm assemblies.
20. Lower the discharge chute.

Servicing the Cutting Blades

To ensure a superior quality of cut, keep the blades sharp. For convenient sharpening and replacement, keep extra blades on hand.

⚠ WARNING

A worn or damaged blade can break, and a piece of the blade could be thrown at you or bystanders, resulting in serious personal injury or death.

- Inspect the blades periodically for wear or damage.
- Replace a worn or damaged blade.

Before Inspecting or Servicing the Blades

1. Park the machine on a level surface, Disengage the blade-control switch (PTO), and set the parking brake.
2. Turn the ignition key to off. Remove the key, and disconnect the spark plug wires from the spark plugs.

Inspecting the Blades

Service Interval: Before each use or daily

1. Inspect the cutting edges (Figure 98).
2. If the edges are not sharp or have nicks, remove and sharpen the blade; refer to [Removing the Blades](#) (page 67) and [Sharpening the Blades](#) (page 68).
3. Inspect the blades, especially in the curved area.
4. If you notice any cracks, wear, or a slot forming in this area, immediately install a new blade (Figure 98).

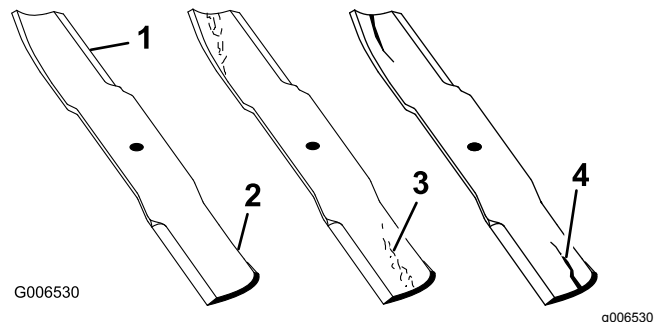

Figure 98

1. Cutting edge
2. Curved area
3. Wear/slot forming
4. Crack

Checking for Bent Blades

1. Disengage the blade-control switch (PTO), move the motion-control levers to the NEUTRAL-LOCK position, and set the parking brake.
2. Shut off the engine, remove the key, and wait for all moving parts to stop before leaving the operating position.
3. Rotate the blades until the ends face forward and backward (Figure 99).
4. Measure from a level surface to the cutting edge, position A, of the blades (Figure 99).

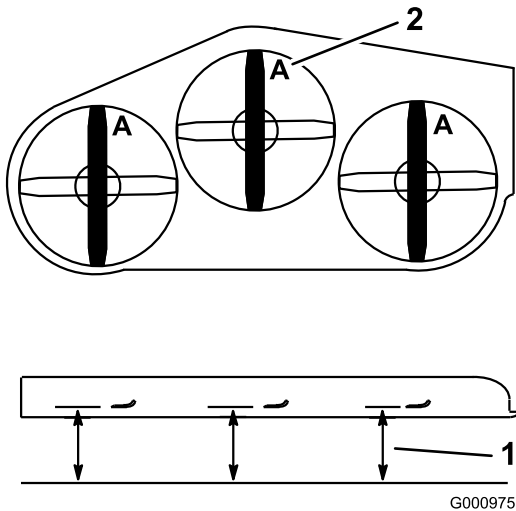

Figure 99

1. Measure here from blade to hard surface
2. Position A

5. Rotate the opposite ends of the blades forward.
6. Measure from a level surface to the cutting edge of the blades at the same position as in step 4.

Note: The difference between the dimensions obtained in steps 4 and 5 must not exceed 3 mm (1/8 inch).

Note: If this dimension exceeds 3 mm (1/8 inch), the blade is bent and must be replaced.

⚠ WARNING

A blade that is bent or damaged could break apart and could seriously injure or kill you or bystanders.

- Always replace bent or damaged blade with a new blade.
- Do not file or create sharp notches in the edges or surfaces of the blade.

Removing the Blades

Replace a blade if it hits an object, if the blade is out of balance, or if the blade is bent. To ensure optimum performance and continued safety conformance of the machine, use genuine Toro replacement blades. Replacement blades made by other manufacturers may result in nonconformance with safety standards.

1. Hold the blade end using a rag or a thickly padded glove.
2. Remove the blade bolt, curved washer, and blade from the spindle shaft (Figure 100).

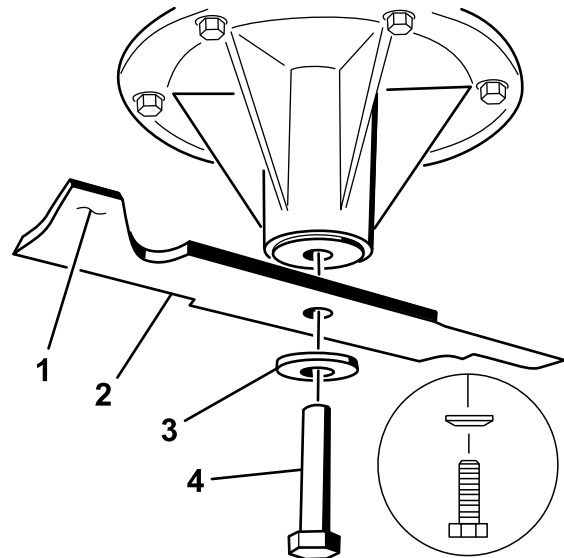

Figure 100

1. Sail area of the blade
2. Blade
3. Curved washer
4. Blade bolt

Sharpening the Blades

1. Use a file to sharpen the cutting edge at both ends of the blade (Figure 101).

Note: Maintain the original angle.

Note: The blade retains balance if you remove the same amount of material from both cutting edges.

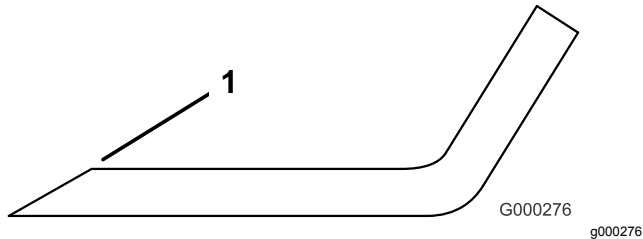

Figure 101

1. Sharpen at the original angle

2. Check the balance of the blade by putting it on a blade balancer (Figure 102).

Note: If the blade stays in a horizontal position, the blade is balanced and ready to use.

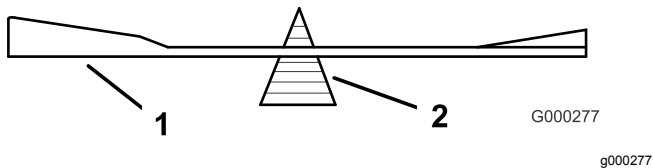

Figure 102

1. Blade
2. Balancer

3. If the blade is not balanced, file some metal off the end of the sail area only (Figure 100).
4. Repeat this procedure until the blade is balanced.

Installing the Blades

1. Install the blade onto the spindle shaft (Figure 103).

Important: The curved part of the blade must point upward toward the inside of the mower to ensure proper cutting.

2. Install the spring disk and blade bolt (Figure 103).

Note: Install the spring-disk cone toward the bolt head.

3. Torque the blade bolt to 115 to 150 N·m (85 to 110 ft·lb).

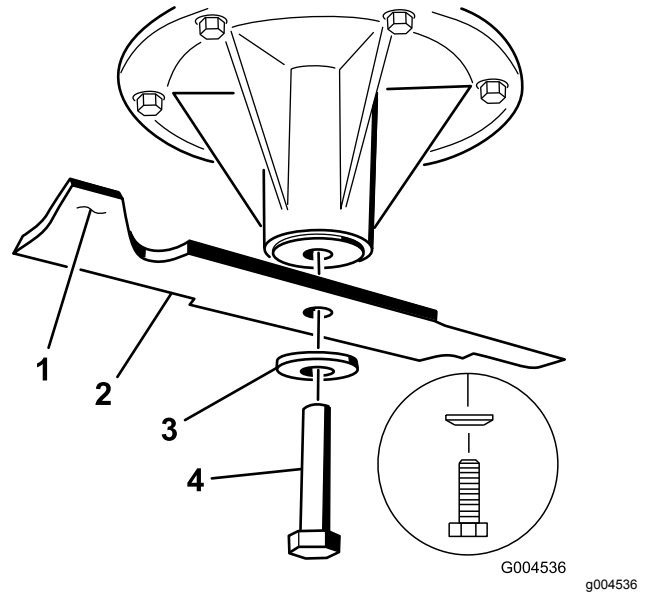

Figure 103

1. Sail area of the blade
2. Blade
3. Spring disk
4. Blade bolt

Removing the Mower Deck

Before servicing or removing the mower deck, lock out the spring-loaded deck arms.

⚠ WARNING

Deck-lift-arm assemblies have stored energy. Removing the deck without releasing the stored energy can cause serious injury or death.

Do not attempt to disassemble the deck from the front frame without locking out the stored energy.

1. Shut off the engine, wait for all of the moving parts to stop, remove the key, and engage parking brake.
2. Remove the height-adjustment pin and lower the deck to the ground.
3. Place the height-adjustment pin in the 7.6 cm (3 inch) height-of-cut location.

Note: This locks the deck-lift arms in the lowest position so that when you remove the deck, the stored energy in the deck spring is released.

4. Remove the belt covers.
5. Lift the floor pan and insert a ratchet into the square hole in the deck idler ([Figure 104](#)).
6. Rotate the deck idler clockwise and remove the mower belt ([Figure 104](#)).

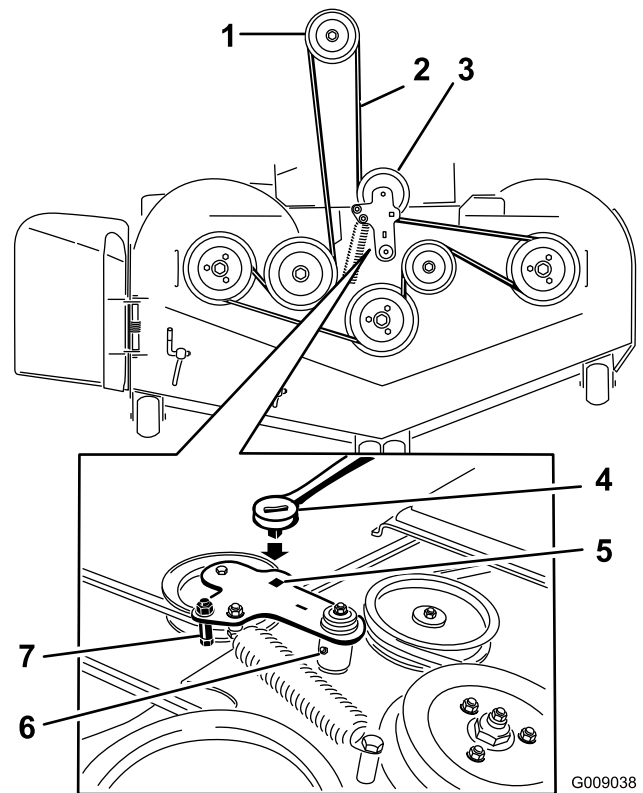

Figure 104

G009038
g009038

- | | |
|-------------------------------|---|
| 1. Clutch pulley | 5. Square hole in the idler arm for the ratchet |
| 2. Mower belt | 6. Idler grease fitting |
| 3. Spring-loaded idler pulley | 7. Belt guide |
| 4. Ratchet | |
-
7. Remove and retain the hardware on both sides of the deck as shown in [Figure 105](#).

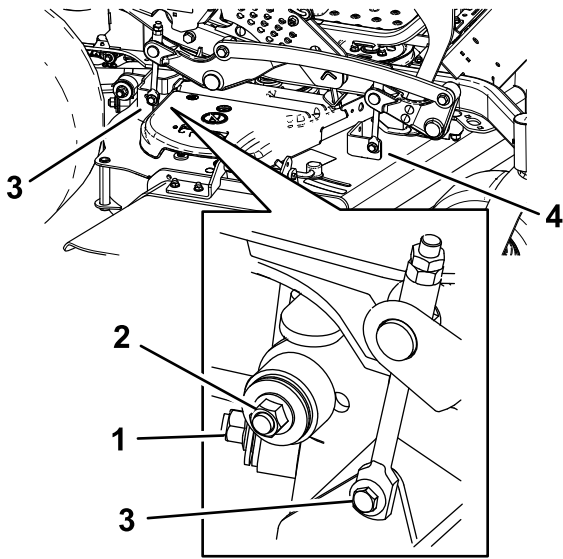

Figure 105

g029652

1. Right stabilizer
2. Deck strut (right side shown)
3. Remove the shoulder bolt and nut.
4. Remove the shoulder bolt and nut.

8. Raise the deck struts and secure them in the up position.
9. Slide the deck out to the right side of the machine.

Replacing the Grass Deflector

⚠ WARNING

An uncovered discharge opening could allow the lawn mower to throw objects at you or bystanders, resulting in serious injury. Also, contact with the blade could occur.

Do not operate the lawn mower unless you install a cover plate, mulch plate, grass deflector, or bagger.

1. Remove the locknut, bolt, spring, and spacer holding the deflector to the pivot brackets (Figure 106).
2. Remove the damaged or worn grass deflector (Figure 106).

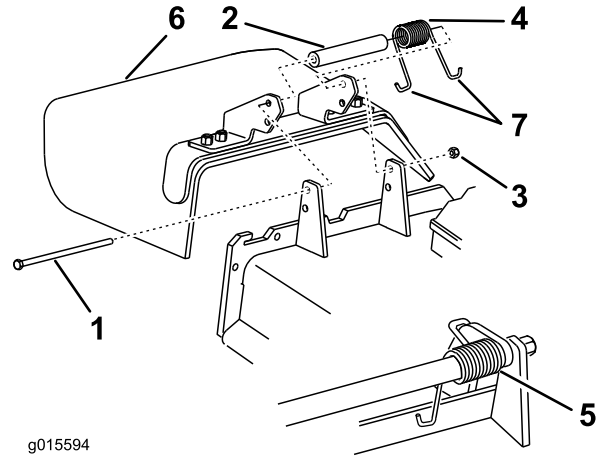

g015594

g015594

Figure 106

- | | |
|------------|-------------------------|
| 1. Bolt | 5. Spring installed |
| 2. Spacer | 6. Grass deflector |
| 3. Locknut | 7. J-hook end of spring |
| 4. Spring | |

3. Place the spacer and the spring onto grass deflector.
4. Place 1 J-hook end of the spring behind the deck edge.

Note: Make sure that 1 J-hook end of the spring is installed behind the deck edge before installing the bolt as shown in Figure 106.

5. Install the bolt and the nut.
6. Place 1 J-hook end of the spring around the grass deflector (Figure 106).

Important: The grass deflector must be able to rotate. Lift the deflector up to the full open position and ensure that it rotates into the fully down position.

Cleaning

Cleaning under the Mower

Service Interval: Before each use or daily

1. Disengage the blade-control switch (PTO), move the motion-control levers to the NEUTRAL-LOCK position, and set the parking brake.
2. Shut off the engine, remove the key, and wait for all moving parts to stop before leaving the operating position.
3. Raise the mower to the TRANSPORT position.

Cleaning the Suspension System

Note: Do not clean the shock assemblies with pressurized water (Figure 107).

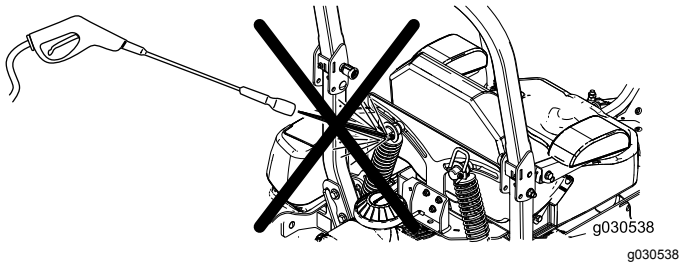

Figure 107

Disposing of Waste

Engine oil, batteries, hydraulic fluid, and engine coolant are pollutants to the environment. Dispose of these according to your state and local regulations.

Storage

Cleaning and Storage

1. Disengage the blade-control switch (PTO), set the parking brake, and turn the ignition key to Off. Remove the key.
2. Remove grass clippings, dirt, and grime from the external parts of the entire machine, especially the engine and hydraulic system. Clean dirt and chaff from the outside of the engine-cylinder-head fins and blower housing.
Important: You can wash the machine with mild detergent and water. Do not pressure-wash the machine. Avoid excessive use of water, especially near the control panel, engine, hydraulic pumps, and motors.
3. Check the brake.
4. Service the air cleaner; refer to [Servicing the Air Cleaner \(page 40\)](#).
5. Grease the machine; refer to [Lubrication \(page 37\)](#).
6. Change the crankcase oil; refer to [Changing the Engine Oil \(page 42\)](#).
7. Check the tire pressure; refer to [Checking the Tire Pressure \(page 51\)](#).
8. Change the hydraulic filters; refer to [Replacing the Hydraulic Filters and Hydraulic Fluid \(page 63\)](#).
9. Charge the battery; refer to [Charging the Battery \(page 48\)](#).
10. Scrape any heavy buildup of grass and dirt from the underside of the mower, then wash the mower with a garden hose.

Note: Run the machine with the blade-control switch (PTO) engaged, and the engine at high idle for 2 to 5 minutes after washing.

11. Check the condition of the blades; refer to [Servicing the Cutting Blades \(page 66\)](#).
12. Prepare the machine for storage when non-use occurs over 30 days. Prepare the machine for storage as follows:
 - A. Add a petroleum-based stabilizer/conditioner to fuel in the tank. Follow mixing instructions from the stabilizer manufacturer. Do not use an alcohol based stabilizer (ethanol or methanol).

Note: A fuel stabilizer/conditioner is most effective when mixed with fresh fuel and used at all times.

- B. Run the engine to distribute conditioned fuel through the fuel system (5 minutes).
- C. Shut off the engine, allow it to cool, and drain the fuel tank; refer to [Servicing the Fuel Tank \(page 46\)](#).
- D. Restart the engine and run it until it stops.
- E. Dispose of fuel properly. Recycle as per local codes.

***Important:* Do not store stabilizer/conditioned fuel over 90 days.**

- 13. Check and tighten all bolts, nuts, and screws. Repair or replace any part that is damaged.
- 14. Paint all scratched or bare metal surfaces. Paint is available from your Authorized Service Dealer.
- 15. Store the machine in a clean, dry garage or storage area.
- 16. Remove the key from the ignition switch and keep it out of reach of children or other unauthorized users.
- 17. Cover the machine to protect it and keep it clean.

Troubleshooting

Problem	Possible Cause	Corrective Action
The malfunction indicator light (MIL) comes on.	<ol style="list-style-type: none"> 1. The engine is too hot. 2. There is old gas in the gas tank. 3. The fuel-shutoff valve is not open completely. 4. The air cleaner is dirty. 5. The battery is not charged. 6. Incorrect fuel filters are being used or the fuel filters are dirty. 7. The connections to the sensors electronic control unit (ECU) and fuel injectors are not secured properly. 8. There is low voltage from the battery. 9. A fuse is blown. 	<ol style="list-style-type: none"> 1. Turn the engine off and let it cool. 2. Use new gas. 3. Open the fuel-shutoff valve. 4. Make sure that the air cleaner and precleaner are clean. Replace if necessary. 5. Charge or replace the battery. 6. Contact an Authorized Service Dealer. 7. Contact an Authorized Service Dealer. 8. Ensure a good 12-volt battery is being used and is fully charged. 9. Check and replace any blown fuses.
The starter does not crank.	<ol style="list-style-type: none"> 1. The blade-control switch (PTO) is engaged. 2. The parking brake is not engaged. 3. The motion-control levers are not in the NEUTRAL-LOCK position. 4. The operator is not seated. 5. The battery is dead. 6. The electrical connections are corroded or loose. 7. The fuse is blown. 8. The relay or switch is worn or damaged. 	<ol style="list-style-type: none"> 1. Move the blade-control switch (PTO) to the disengaged position. 2. Set the parking brake. 3. Ensure that the motion-control levers are in the NEUTRAL-LOCK position. 4. Sit on the seat. 5. Charge the battery. 6. Check the electrical connections for good contact. 7. Replace the fuse. 8. Contact an Authorized Service Dealer.
The engine does not start, starts hard, or fails to keep running.	<ol style="list-style-type: none"> 1. The fuel tank is empty. 2. The fuel-shutoff valve is closed. 3. The oil level in the crankcase is low. 4. The throttle is not in the correct position. 5. There is dirt in the fuel filter. 6. There is dirt, water, or stale fuel in the fuel system. 7. The air cleaner is dirty. 8. The seat switch is not functioning properly. 9. The electrical connections are corroded, loose, or damaged. 10. The relay or switch is worn or damaged. 11. The spark plug is fouled or improperly gapped. 12. The spark-plug wire is not connected. 	<ol style="list-style-type: none"> 1. Fill the fuel tank. 2. Open the fuel-shutoff valve. 3. Add oil to the crankcase. 4. Be sure that the throttle control is midway between the slow and fast positions. 5. Replace the fuel filter. 6. Contact an Authorized Service Dealer. 7. Clean or replace the air-cleaner element. 8. Check the seat-switch indicator. Replace the seat if necessary. 9. Check the electrical connections for good contact. Clean the connector terminals thoroughly with electrical-contact cleaner, apply dielectric grease, and make the appropriate connections. 10. Contact an Authorized Service Dealer. 11. Adjust or replace the spark plug. 12. Check the spark-plug wire connection.

Problem	Possible Cause	Corrective Action
The engine loses power.	<ol style="list-style-type: none"> 1. The engine load is excessive. 2. The air cleaner is dirty. 3. The oil level in the crankcase is low. 4. The cooling fins and the air passages above the engine are plugged. 5. The vent hole in the fuel cap is plugged. 6. There is dirt in the fuel filter. 7. There is dirt, water, or stale fuel in the fuel system. 	<ol style="list-style-type: none"> 1. Reduce the ground speed. 2. Clean the air-cleaner element. 3. Add oil to the crankcase. 4. Remove the obstruction from the cooling fins and the air passages. 5. Clean or replace the fuel cap. 6. Replace the fuel filter. 7. Contact an Authorized Service Dealer.
The engine overheats.	<ol style="list-style-type: none"> 1. The engine load is excessive. 2. The oil level in the crankcase is low. 3. The cooling fins and the air passages above the engine are plugged. 	<ol style="list-style-type: none"> 1. Reduce the ground speed. 2. Add oil to the crankcase. 3. Remove the obstruction from the cooling fins and the air passages.
The mower pulls left or right (with levers fully forward).	<ol style="list-style-type: none"> 1. The tracking needs adjustment 2. The tire pressure is not correct in the drive tires. 	<ol style="list-style-type: none"> 1. Adjust the tracking. 2. Adjust the tire pressure in the drive tires.
The machine does not drive.	<ol style="list-style-type: none"> 1. The bypass valves are not closed tight. 2. The pump belt is worn, loose or broken. 3. The pump belt is off a pulley. 4. The idler spring is broken or missing. 5. The hydraulic-fluid level is low or too hot. 	<ol style="list-style-type: none"> 1. Tighten the bypass valves. 2. Change the belt. 3. Change the belt. 4. Replace the spring. 5. Add hydraulic fluid to reservoirs or let it cool down.
There is abnormal vibration.	<ol style="list-style-type: none"> 1. The cutting blade(s) is/are bent or unbalanced. 2. The blade mounting bolt is loose. 3. The engine mounting bolts are loose. 4. The engine pulley, idler pulley, or blade pulley is loose. 5. The engine pulley is damaged. 6. The blade spindle is bent. 7. The motor mount is loose or worn. 	<ol style="list-style-type: none"> 1. Install new cutting blade(s). 2. Tighten the blade mounting bolt. 3. Tighten the engine mounting bolts. 4. Tighten the appropriate pulley. 5. Contact an Authorized Service Dealer. 6. Contact an Authorized Service Dealer. 7. Contact an Authorized Service Dealer.
The machine produces an uneven cutting height.	<ol style="list-style-type: none"> 1. The blade(s) is/are not sharp. 2. The cutting blade(s) is/are bent. 3. The mower deck is not level. 4. The underside of mower is dirty. 5. The tire pressure is not correct. 6. The blade spindle is bent. 	<ol style="list-style-type: none"> 1. Sharpen the blade(s). 2. Install new cutting blade(s). 3. Level the mower deck from side-to-side and front-to-rear. 4. Clean the underside of the mower. 5. Adjust the tire pressure. 6. Contact an Authorized Service Dealer.
The blades do not rotate.	<ol style="list-style-type: none"> 1. The mower deck belt is worn, loose, or broken. 2. The mower deck belt is off the pulley. 3. The pump drive belt is worn, loose, or broken. 4. The idler spring is broken or missing. 	<ol style="list-style-type: none"> 1. Install a new deck belt. 2. Install the mower deck pulley and check the idler pulley, idler arm, and spring for correct position and function. 3. Check the belt tension or install a new belt. 4. Replace the spring.

Problem	Possible Cause	Corrective Action
The clutch does not engage.	<ol style="list-style-type: none"> 1. The fuse is blown. 2. There is low voltage supply at the clutch. 3. The coil is damaged. 4. There is inadequate current supply. 5. The rotor/armature air gap is too large. 	<ol style="list-style-type: none"> 1. Replace the fuse. Check the coil resistance, battery charge, charging system, and wiring connections, and replace components if necessary. 2. Check the coil resistance, battery charge, charging system, and wiring connections and replace parts if necessary. 3. Replace the clutch. 4. Repair or replace the clutch lead wire or electrical system. Clean the connector contacts. 5. Remove the shim or replace the clutch.

Schematics

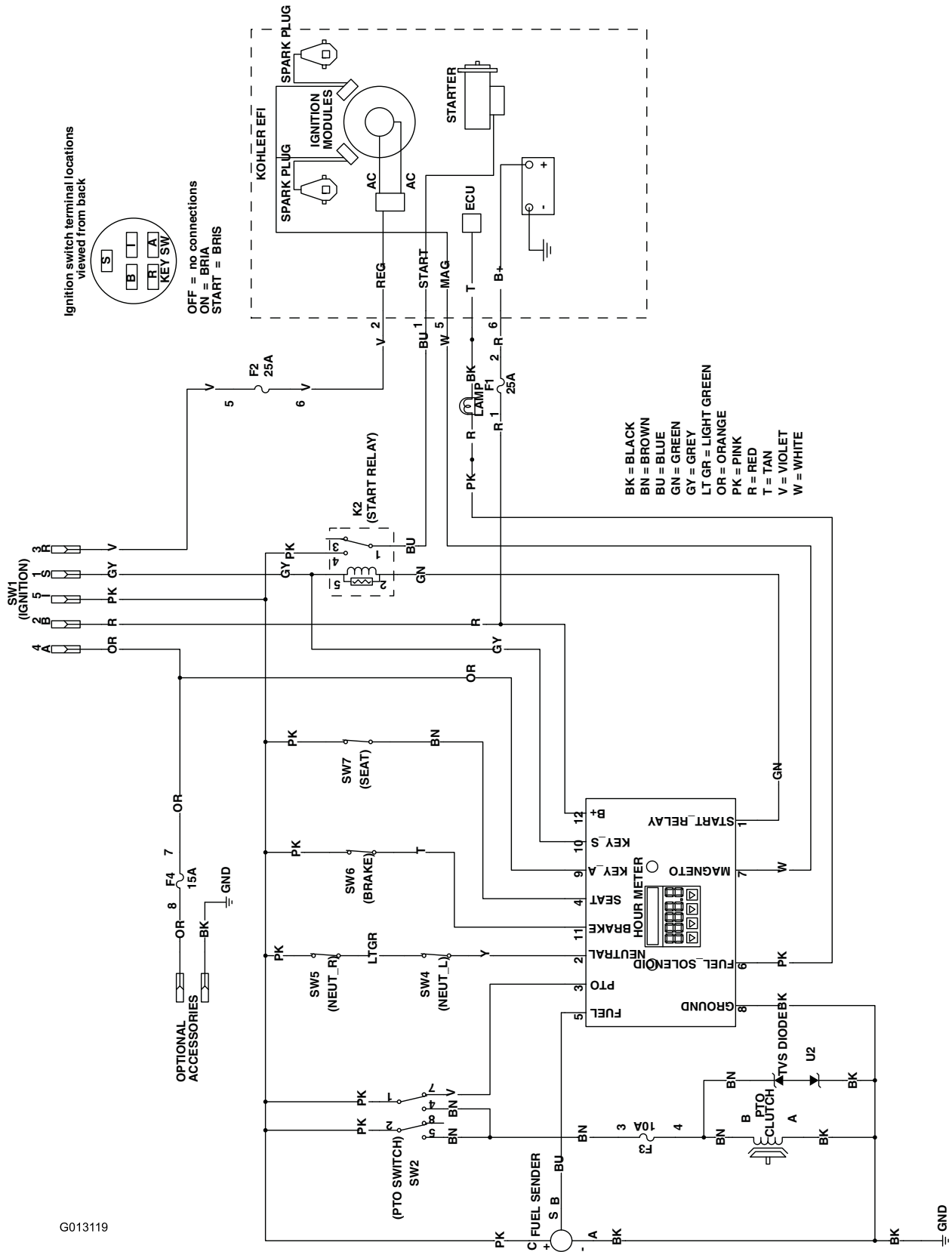

G013119

g013119

Wire Diagram (Rev. A)

Notes:

Notes:



The Toro Warranty

A Limited Warranty (see warranty periods below)

Landscape
Contractor
Equipment
(LCE)

Conditions and Products Covered

The Toro Company and its affiliate, Toro Warranty Company, pursuant to an agreement between them, jointly promise to the original purchaser to repair the Toro Products listed below if defective in materials or workmanship.

The following time periods apply from the date of purchase:

Products	Warranty Period
21 in. Mowers	2 years Residential Use ¹ 1 year Commercial Use
• Engines ³	Honda – 2 years Kawasaki – 3 years
30 in. Mowers	2 years Residential Use ¹ 1 year Commercial Use
• Engines ³	Kawasaki – 3 years
Mid-Size Walk-Behind Mowers	2 years
• Engines ³	Kawasaki – 3 years
Grand Stand® Mowers	5 years or 1,200 hours ²
• Engines ³	3 years
Z Master® 2000 Series Mowers	4 years or 500 hours ²
• Engines ³	3 years
Z Master® 3000 Series Mowers	5 years or 1,200 hours ²
• Engines ³	3 years
Z Master® 5000 Series Mowers	5 years or 1,200 hours ²
• Engines ³	Kohler Command – 2 years Kohler EFI – 3 years
Z Master® 6000 Series Mowers	5 years or 1,200 hours ²
• Engines ³	Kawasaki – 3 years
Z Master® 7000 Series Mowers	5 years or 1,200 hours ²
• Engines ³	2 years
Z Master® 8000 Series Mowers	2 years or 1,200 hours ²
• Engines ³	2 years
All Mowers	
• Battery	90 days Parts and Labor 1 year Parts only
• Belts and Tires	90 days
• Attachments	1 year

¹Residential use means use of the product on the same lot as your home. Use at more than one location is considered commercial use and the commercial warranty would apply.

²Whichever occurs first.

³Some engines used on Toro Products are warranted by the engine manufacturer.

Instructions for Obtaining Warranty Service

If you think that your Toro Product contains a defect in materials or workmanship, follow this procedure:

- Contact any Authorized Toro Service Dealer to arrange service at their dealership. To locate a dealer convenient to you, access our web site at www.Toro.com. You may also call the numbers listed in item #3 to use the 24-hour Toro Dealer locator system.
- Bring the product and your proof of purchase (sales receipt) to the Service Dealer. The dealer will diagnose the problem and determine if it is covered under warranty.
- If for any reason you are dissatisfied with the Service Dealer's analysis or with the assistance provided, contact us at:

Toro Warranty Company
8111 Lyndale Avenue South
Bloomington, MN 55420-1196
888-865-5676 (U.S. Customers)
888-865-5691 (Canada customers)

Owner Responsibilities

You must maintain your Toro Product by following the maintenance procedures described in the *Operator's Manual*. Such routine maintenance, whether performed by a dealer or by you, is at your expense.

Items and Conditions Not Covered

There is no other express warranty except for special emission system coverage and engine warranty coverage on some products. This express warranty does not cover the following:

- Cost of regular maintenance service or parts, such as filters, fuel, lubricants, oil changes, spark plugs, air filters blade sharpening or worn blades, cable/linkage adjustments, or brake and clutch adjustments
- Components failing due to normal wear
- Any product or part which has been altered or misused or neglected or requires replacement or repair due to accidents or lack of proper maintenance
- Pickup and delivery charges
- Repairs or attempted repairs by anyone other than an Authorized Toro Service Dealer
- Repairs necessary due to failure to follow recommended fuel procedure (consult *Operator's Manual* for more details)
 - Removing contaminants from the fuel system is not covered
 - Use of old fuel (more than one month old) or fuel which contains more than 10% ethanol or more than 15% MTBE
 - Failure to drain the fuel system prior to any period of non-use over one month

General Conditions

All repairs covered by these warranties must be performed by an Authorized Toro Service Dealer using Toro approved replacement parts.

Neither The Toro Company nor Toro Warranty Company is liable for indirect, incidental or consequential damages in connection with the use of the Toro Products covered by this warranty, including any cost or expense of providing substitute equipment or service during reasonable periods of malfunction or non-use pending completion of repairs under this warranty.

All implied warranties of merchantability (that the product is fit for ordinary use) and fitness for use (that the product is fit for a particular purpose) are limited to the duration of the express warranty.

Some states do not allow exclusions of incidental or consequential damages, or limitations on how long an implied warranty lasts, so the above exclusions and limitations may not apply to you.

This warranty gives you specific legal rights, and you may also have other rights which vary from state to state.

Countries Other than the United States or Canada

Customers who have purchased Toro products outside the United States or Canada should contact their Toro Distributor (Dealer) to obtain guarantee policies for your country, province, or state. If for any reason you are dissatisfied with your Distributor's service or have difficulty obtaining guarantee information, contact the Toro importer. If all other remedies fail, you may contact us at Toro Warranty Company.

Australian Consumer Law: Australian customers will find details relating to the Australian Consumer Law either inside the box or at your local Toro Dealer. 374-0252 Rev H