



Wheel Horse®
520xi Tractor

Model No. 73570 – 9900001 & UP

Operator's Manual

IMPORTANT: Read this manual carefully. It contains information about your safety and the safety of others. Also become familiar with the controls and their proper use before you operate the product.

Introduction

Thank you for purchasing a Toro product.

All of us at Toro want you to be completely satisfied with your new product, so feel free to contact your local Authorized Service Dealer for help with service, genuine replacement parts, or other information you may require.

Whenever you contact your Authorized Service Dealer or the factory, always know the model and serial numbers of your product. These numbers will help the Service Dealer or Service Representative provide exact information about your specific product. You will find the model and serial number plate located in a unique place on the product as shown below.

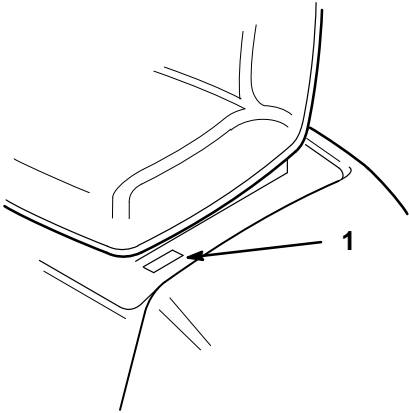

m-2345

1. Model and Serial Number Plate

For your convenience, write the product model and serial numbers in the space below.

Model No: _____
Serial No. _____

Read this manual carefully to learn how to operate and maintain your product correctly. Reading this manual will help you and others avoid personal injury and damage to the product. Although we design, produce and market safe, state-of-the-art products, you are responsible for using the product properly and safely. You are also responsible for training persons, you allow to use the product, about safe operation.

The warning system in this manual identifies potential hazards and has special safety messages that help you and others avoid personal injury, even death. **DANGER**, **WARNING** and **CAUTION** are signal words used to identify the level of hazard. However, regardless of the hazard, be extremely careful.

DANGER signals an extreme hazard that will cause serious injury or death if the recommended precautions are not followed.

WARNING signals a hazard that may cause serious injury or death if the recommended precautions are not followed.

CAUTION signals a hazard that may cause minor or moderate injury if the recommended precautions are not followed.

Two other words are also used to highlight information. “Important” calls attention to special mechanical information and “Note” emphasizes general information worthy of special attention.

The left and right side of the machine is determined by sitting on the seat in the normal operator’s position.

Contents

	Page		Page
Safety	2	Positioning the Seat	25
Safe Operation Practices for Ride-on (riding)		Headlights and Taillights	25
Rotary Lawnmower Machines	2	Positioning the Tilt Steering Wheel	25
Safe Operating Practices	2	Using the Cruise Control	26
Sound Pressure Level	4	The Smart Turnt Steering Feature	27
Sound Power Level	4	Pushing the Machine by Hand	27
Vibration Level	4	Maintenance	28
Slope Chart	5	Service Interval Chart	28
Safety and Instruction Decals	7	Air Cleaner	29
Symbols Glossary	8	Engine Oil	31
Symbols Glossary	9	Spark Plugs	33
Symbols Glossary	10	Greasing and Lubrication	34
Check Before Operating	11	Tire Pressure	36
Opening the Hood	11	Brake	36
Closing the Hood	12	Fuel Tank	37
Removing the Side Panels	12	Fuel Filter	38
Adding Fuel	13	Front Wheel Toe-In	39
Check the Engine Oil Level	14	Transaxle Fluid	41
Check for Debris	15	Fuses	43
Check the Safety Interlock System	16	Headlights	43
Check the Brake	16	Taillights	44
Operation	17	Battery	44
Think Safety First	17	Wiring Diagram	48
Controls	17	Cleaning and Storage	49
“Key Choice” Key	17	Troubleshooting	50
Parking Brake	17		
Starting and Stoppingthe Engine	18		
Operating thePower Take Off (PTO)	19		
The Safety Interlock System	19		
Operating–in–Reverse	19		
Gauges and Indicator Lights	22		
Driving Forward or Backward	23		
Stopping the Machine	24		
Attachment Power Lift	24		

Safety

Safe Operation Practices for Ride-on (riding) Rotary Lawnmower Machines

This machine meets or exceeds European Standards in effect at the time of production. However, improper use or maintenance by the operator or owner can result in injury. To reduce the potential for injury, comply with these safety instructions and always pay attention to the safety alert ▲ symbol, which means CAUTION, WARNING, or DANGER—“personal safety instruction.” Failure to comply with the instruction may result in personal injury or death.

Safe Operating Practices

This product is capable of amputating hands and feet and throwing objects. Always follow all safety instructions to avoid serious injury or death.

Training

1. Read the instructions carefully. Be familiar with the controls and the proper use of the equipment.
2. Never allow children or people unfamiliar with these instructions to use the lawnmower. Local regulations may restrict the age of the operator.
3. Never mow while people, especially children, or pets are nearby.
4. Keep in mind that the operator or user is responsible for accidents or hazards occurring to other people or their property.
5. Do not carry passengers.

6. All drivers should seek and obtain professional and practical instruction. Such instruction should emphasize:
 - the need for care and concentration when working with ride-on machines;
 - control of a ride-on machine sliding on a slope will not be regained by the application of the brake. The main reasons for loss of control are:
 - insufficient wheel grip;
 - being driven too fast;
 - inadequate braking;
 - the type of machine is unsuitable for its task;
 - lack of awareness of the effects of ground conditions, especially slopes;
 - incorrect hitching and load distribution.

Preparation

1. While mowing, always wear substantial footwear and long trousers. Do not operate the equipment when barefoot or wearing open sandals.
2. Thoroughly inspect the area where the equipment is to be used and remove all objects which may be thrown by the machine.
3. **WARNING** – Fuel is highly flammable.
 - Store fuel in containers specifically designed for this purpose.
 - Refuel outdoors only and do not smoke while refuelling.
 - Add fuel before starting the engine. Never remove the cap of the fuel tank or add fuel while the engine is running or when the engine is hot.

- If fuel is spilled, do not attempt to start the engine but move the machine away from the area of spillage and avoid creating any source of ignition until petrol vapors have dissipated.
 - Replace all fuel tanks and container caps securely.
4. Replace faulty silencers.
 5. Before using, always visually inspect to see that the blades, blade bolts and cutter assembly are not worn or damaged. Replace worn or damaged blades and bolts in sets to preserve balance.
 6. On multi-bladed machines, take care as rotating one blade can cause other blades to rotate.

Operation

1. Do not operate the engine in a confined space where dangerous carbon monoxide fumes can collect.
2. Mow only in daylight or in good artificial light.
3. Before attempting to start the engine, disengage all blade attachment clutches and shift into neutral.
4. Use care when pulling loads or using heavy equipment.
 - Use only approved drawbar hitch points.
 - Limit loads to those you can safely control.
 - Do not turn sharply. Use care when reversing.
 - Use counterweight(s) or wheel weights when suggested in the instruction handbook.
5. Watch out for traffic when crossing or near roadways.
6. Stop the blades before crossing surfaces other than grass.
7. When using any attachments, never direct discharge of material toward bystanders nor allow anyone near the machine while in operation.
8. Never operate the lawnmower with damaged guards or without safety protective devices in place.
9. Do not change the engine governor settings or overspeed the engine. Operating the engine at excessive speeds may increase the hazard of personal injury.
10. Before leaving the operator's position:
 - disengage the power take-off and lower the attachments;
 - change into neutral and set the parking brake;
 - stop the engine and remove the ignition and "Key Choice" keys.
11. Disengage drive to attachments, stop the engine, and disconnect the spark plug wire(s) or remove the ignition key
 - before cleaning blockages or unclogging chute;
 - before checking, cleaning or working on the lawnmower;
 - after striking a foreign object. Inspect the lawnmower for damage and make repairs before restarting and operating the equipment;
 - if the machine starts to vibrate abnormally (check immediately).
12. Disengage drive to attachments when transporting or not in use.
13. Stop the engine and disengage drive to attachment
 - before refuelling;
 - before removing the grass catcher;

- before making height adjustment unless adjustment can be made from the operator's position.
14. Reduce the throttle setting during engine run-out and, if the engine is provided with a shut-off valve, turn the fuel off at the conclusion of mowing.

Slope Operation

1. For operation on slopes:
 - Never mow side hills over 5°
 - Never mow uphill over 10°
 - Never mow downhill over 15°
2. Remember there is no such thing as a "safe" slope. Travel on grass slopes requires particular care. To guard against overturning:
 - do not stop or start suddenly when going up or downhill;
 - engage clutch slowly, always keep machine in gear, especially when travelling downhill;
 - machine speeds should be kept low on slopes and during tight turns;
 - stay alert for bumps and hollows and other hidden hazards;
 - never mow across the face of the slope, unless the lawnmower is designed for this purpose.

Maintenance and storage

1. Keep all nuts, bolts and screws tight to be sure the equipment is in safe working condition.
2. Never store the equipment with fuel in the tank inside a building where fumes may reach an open flame or spark.
3. Allow the engine to cool before storing in any enclosure.

4. To reduce the fire hazard, keep the engine, silencer, battery compartment and petrol storage area free of grass, leaves, or excessive grease.
5. Check the grass catcher frequently for wear or deterioration.
6. Replace worn or damaged parts for safety.
7. If the fuel tank has to be drained, this should be done outdoors.
8. On multi-bladed machines, take care as rotating one blade can cause other blades to rotate.
9. When machine is to be parked, stored or left unattended, lower the cutting means unless a positive mechanical lock is used.

Sound Pressure Level

This unit has an equivalent continuous A-weighted sound pressure at the operator ear of: 90 dB(A), based on measurements of identical machines per Directive 84/538/EEC and amendments.

Sound Power Level

This unit has a sound power level of: 105 Lwa, based on measurements of identical machines per procedures outlined in Directive 84/538/EEC and amendments.

Vibration Level

This unit has a maximum hand-arm vibration level of 9.0 m/s² and whole body vibration level of 0.2 m/s², based on measurements of identical machines per EN 1033 and EN 1032.

Slope Chart

Read all safety instructions on pages 2–10.

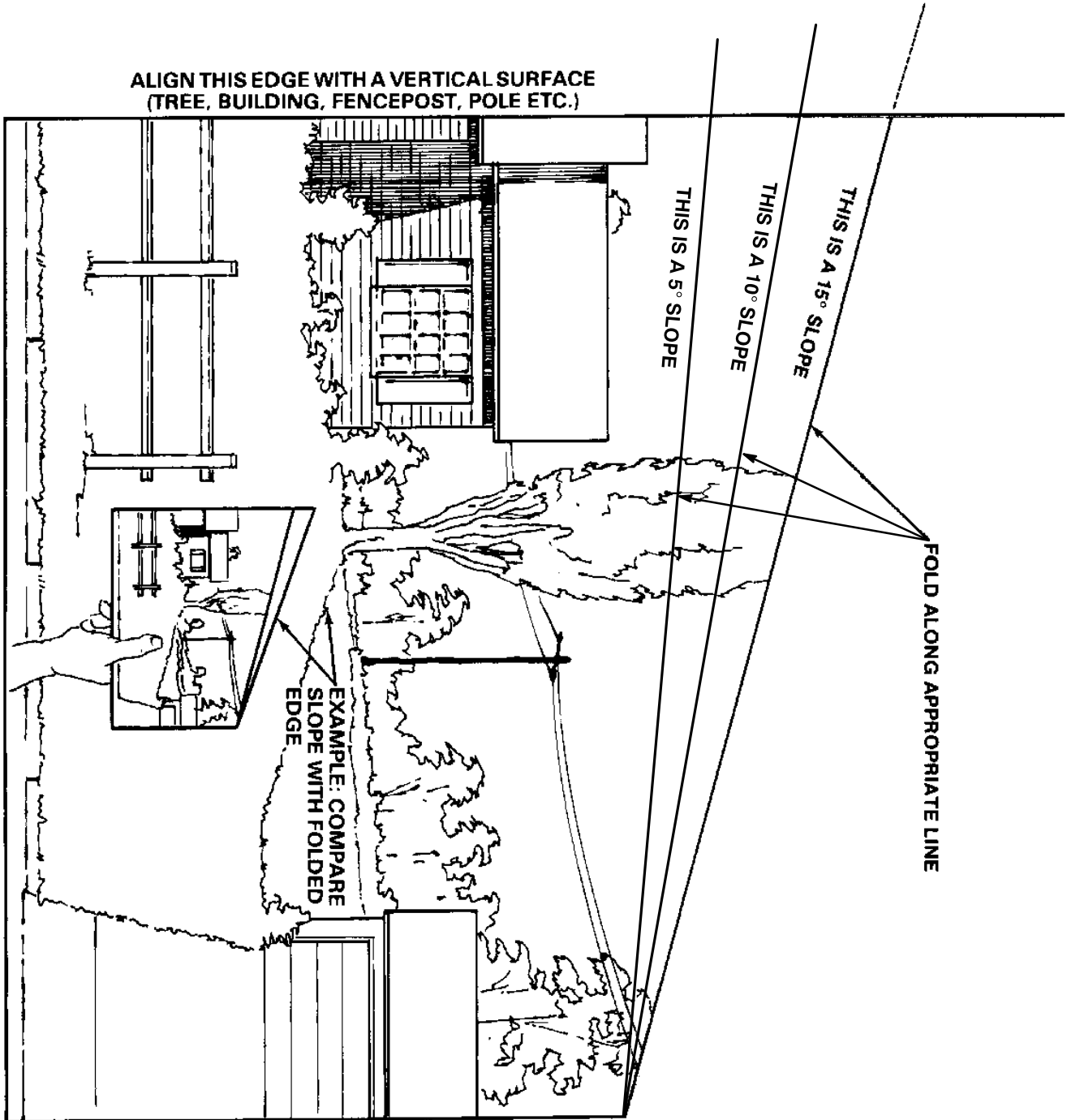

Safety and Instruction Decals



Safety decals and instructions are easily visible to the operator and are located near any area of potential danger. Replace any decal that is damaged or lost.

ON DRIVE SHAFT COVER
(Part No. 98-1608)

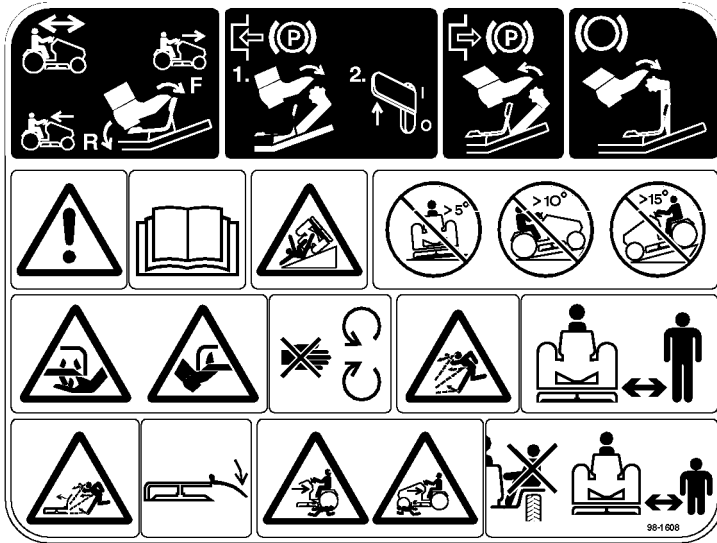

ON SEAT BRACKET
(Part No. 99-2986)

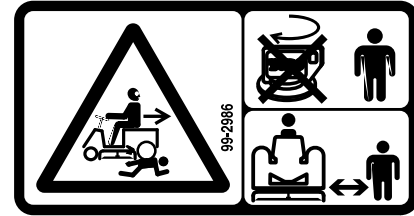

ON SEAT BRACKET
(Part No. 99-5340)

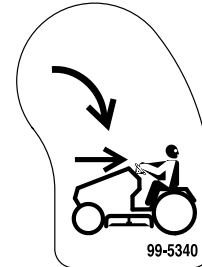

ON BATTERY STRAP
(Part No. 93-1265)

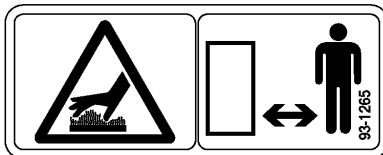

ON DRIVE SHAFT TUNNEL
ON ENGINE BULKHEAD
(2) UNDER SIDE SHIELD
(Part No. 98-5015)

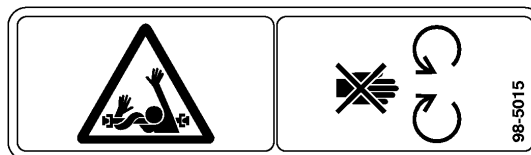

Symbols Glossary

Safety alert symbol		Dismemberment—Mower in rearward motion	
Safety alert symbol		Stay a safe distance from the machine	
Read operator's manual		Stay a safe distance from the mower	
Consult Technical Manual for proper service procedures		Keep children a safe distance from machine	
Thrown or flying objects—Whole body exposure		Machine rollover side hill	
Thrown or flying objects—Rotary side-mounted mower. Keep deflector shield in place		Machine rollover up hill	
Severing toes or foot—mower blade		Machine rollover down hill	
Severing fingers or hand—mower blade		Machine rollover	
Rotating blade can cut off toes or fingers. Stay clear of blade as long as engine is running		Operating in reverse not allowed unless deactivated by "Key Choice" key	
Do not open or remove safety shields while engine is running			

Symbols Glossary

Cutting element–
basic symbol



Cutting element–
height adjustment



Cutting unit–lower

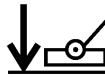

Cutting unit–raised

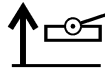

Cutting or entanglement
of foot–Rotating auger



Severing of fingers or hand–
impeller blade



Keep a safe distance from
snowthrower



Stay a safe distance
from the snowthrower

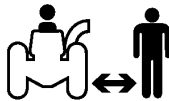

Tractors must be equipped
with 45kg rear wheel weight
with this attachment installed



Machine rollover
ROPS snowthrower



Severing of hand–
Rotating knives



Severing of foot–
Rotating knives



Riding on this machine is allowed
only on a passenger seat & only
if the driver's view is not hindered



Crushing of fingers
or hands–Force applied
from side



Kickback or upward
motion–Stored energy



Shut off engine & remove key
before performing maintenance
or repair work



Machine travel direction–
combined



Low

L

High

H

Reverse

R

Neutral

N

First gear

1



























Second gear

2

Third gear up to
maximum # of
forward gears

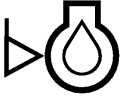
3

Symbols Glossary

Fast		Fuel	
Slow		Fuel level	
Decreasing/Increasing		Volume empty	
On/Run		Volume full	
Off/Stop		Battery charging condition	
Engine		Head lights— Main/high beam	
Engine start		Brake system	
Engine stop		Parking brake	
Choke		Clutch	
Engine temperature		PTO (Power Take Off)	
Engine lubricating oil pressure		Engage	
Engine lubricating oil level		Disengage	
"Key Choice" key		Unlock	
		Lock	

Check Before Operating

Each time before operating your tractor, check the following:

- Fuel level
- Engine oil level
- Debris on the (3) air intake screens
- Debris in the engine area
- Debris on the rear transaxle cover
- The safety interlock system
- The brake

Some of these steps will require that you open the hood or remove the side panels on the tractor.

Opening the Hood

To open the hood:

1. Park the machine on a level surface, disengage the power take off (PTO), set the parking brake, lower the attachment lift, and turn the ignition key to “STOP” to stop the engine. Remove the ignition key.
2. Slide a screwdriver into the right-hand side of the slot shown in Figure 1, and push the hood latch to the left.
3. Raise the hood to full height.

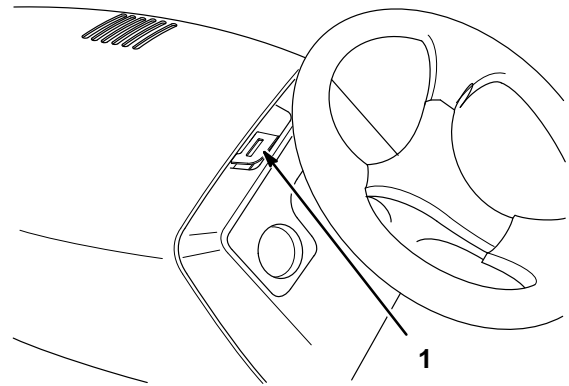

m-3584

Figure 1

1. Slot for hood latch access

CAUTION

POTENTIAL HAZARD

- Components under the hood will be hot if the tractor has been running.

WHAT CAN HAPPEN

- Touching hot components can cause burns.

HOW TO AVOID THE HAZARD

- Allow the tractor to cool before performing maintenance or touching components under the hood.

Closing the Hood

The hood catch is located at the left hand corner of the grille.

1. Press rearward on the hood catch as you begin to lower the hood (Fig. 2).
2. Push the hood down until the latch closes.

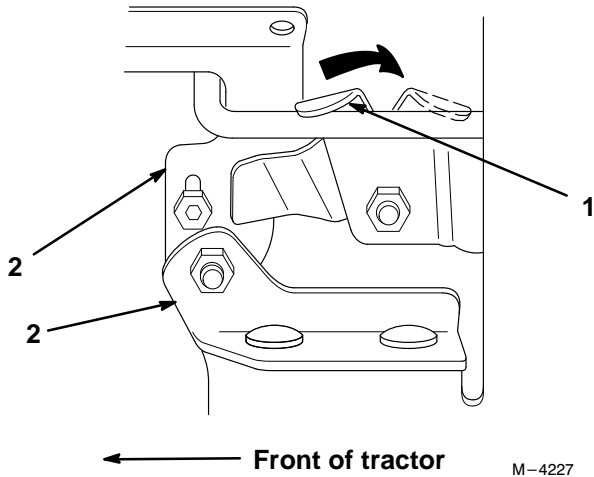

Figure 2

1. Hood catch
2. Hood hinges

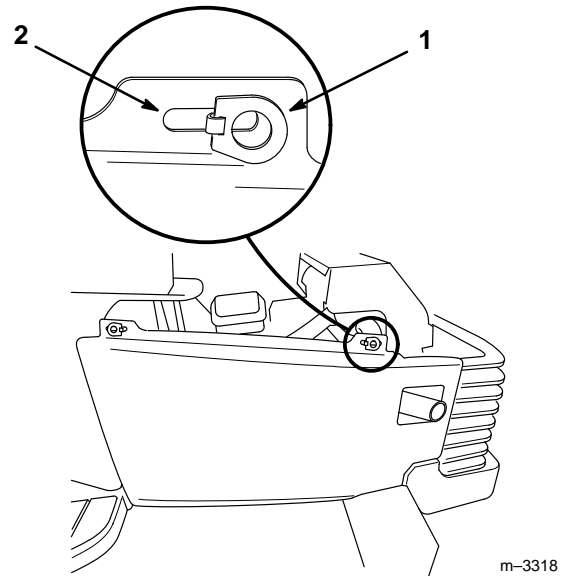

Figure 3

1. Side panel latch
2. Open slot

Removing the Side Panels

1. Park the machine on a level surface, disengage the power take off (PTO), set the parking brake, lower the attachment lift, and turn the ignition key to "STOP" to stop the engine. Remove the ignition key.
2. Raise the hood.
3. To remove a side panel:
 - A. Lift up and twist each of the two side panel latches 90°, or until they line up with the open slot (Fig.3).
 - B. Pull the top of the side panel toward you until the side panel latches pass through the open slot.
 - C. Lift the side panel from the tractor.

Adding Fuel

Use UNLEADED Regular Gasoline suitable for automotive use (85 pump octane minimum). Leaded regular gasoline may be used if unleaded regular is not available.

IMPORTANT: Never use methanol, gasoline containing methanol, or gasohol containing more than 10% ethanol because the fuel system could be damaged. Do not mix oil with gasoline.

DANGER

POTENTIAL HAZARD

- In certain conditions gasoline is extremely flammable and highly explosive.

WHAT CAN HAPPEN

- A fire or explosion from gasoline can burn you, others, and cause property damage.

HOW TO AVOID THE HAZARD

- Use a funnel and fill the fuel tank outdoors, in an open area, when the engine is cold. Wipe up any gasoline that spills.
- Do not fill the fuel tank completely full. Add gasoline to the fuel tank until the level is 1/4" to 1/2" (6 mm to 13 mm) below the bottom of the filler neck. This empty space in the tank allows gasoline to expand.
- Never smoke when handling gasoline, and stay away from an open flame or where gasoline fumes may be ignited by a spark.
- Store gasoline in an approved container and keep it out of the reach of children. Never buy more than a 30-day supply of gasoline.

IMPORTANT: Never use fuel additives containing methanol or ethanol.

DANGER

POTENTIAL HAZARD

- When fueling, under certain circumstances, a static charge can develop, igniting the gasoline.

WHAT CAN HAPPEN

- A fire or explosion from gasoline can burn you and others and cause property damage.

HOW TO AVOID THE HAZARD

- Always place gasoline containers on the ground away from your vehicle before filling.
- Do not fill gasoline containers inside a vehicle or on a truck or trailer bed because interior carpets or plastic truck bed liners may insulate the container and slow the loss of any static charge.
- When practical, remove gas-powered equipment from the truck or trailer and refuel the equipment with its wheels on the ground.
- If this is not possible, then refuel such equipment on a truck or trailer from a portable container, rather than from a gasoline dispenser nozzle.
- If a gasoline dispenser nozzle must be used, keep the nozzle in contact with the rim of the fuel tank or container opening at all times until fueling is complete.

Filling the Fuel Tank

1. Park the machine on a level surface, disengage the power take off (PTO), set the parking brake, lower the attachment lift, and turn the ignition key to "STOP" to stop the engine. Remove the ignition key.

2. Clean around the fuel tank cap and remove the cap. Use a funnel and add fuel until the fuel level is 1/4 to 1/2 inch (6 mm to 13 mm) below the bottom of the filler neck. This space in the tank allows for expansion of the fuel. When filling the tank, make sure that the machine is on a level surface so that adequate air space is allowed. Do not fill the fuel tank completely.
3. Install the fuel tank cap securely. Wipe up any gasoline that may have spilled.

Check the Engine Oil Level

1. Park the machine on a level surface, disengage the power take off (PTO), set the parking brake, lower the attachment lift, and turn the ignition key to "STOP" to stop the engine. Remove the ignition key.
2. Open the hood.
3. Clean around the oil dipstick (Fig. 4) so dirt cannot fall into the dipstick tube and damage the engine.
4. Pull out the oil dipstick and wipe the metal end clean (Fig. 5).
5. Slide the oil dipstick fully into the dipstick tube (Fig. 4). Pull the dipstick out and look at the metal end. If the oil level is low, add oil; refer to Engine Oil, page 31.

IMPORTANT: Do not overfill the crankcase with oil because this may result in engine damage.

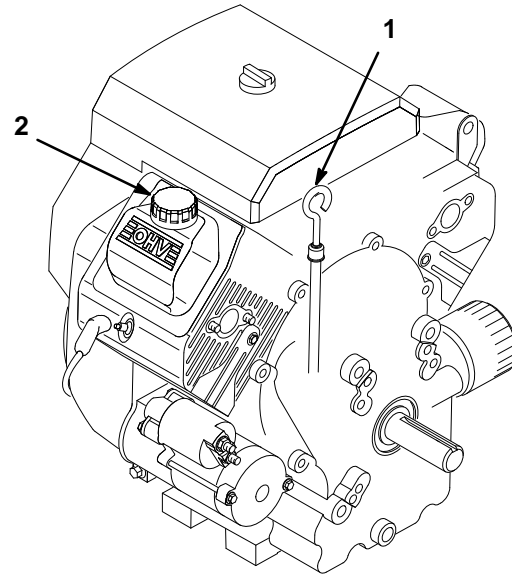

m-3246

Figure 4

1. Dipstick
2. Oil filler

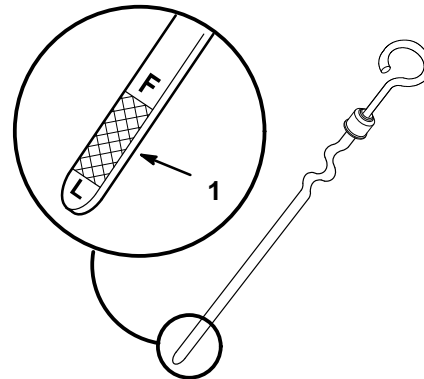

m-3219

Figure 5

1. Metal end

Check for Debris

IMPORTANT: Operating the engine with a blocked grass screen, dirty or plugged cooling fins, and/or cooling shrouds removed, will result in engine damage from overheating.

1. Park the machine on a level surface, disengage the power take off (PTO), set the parking brake, lower the attachment lift, and turn the ignition key to “STOP” to stop the engine. Remove the ignition key.
2. Check for debris on the (3) air intake screens (Fig. 6). Wipe away debris before each use and/or during use, if required.

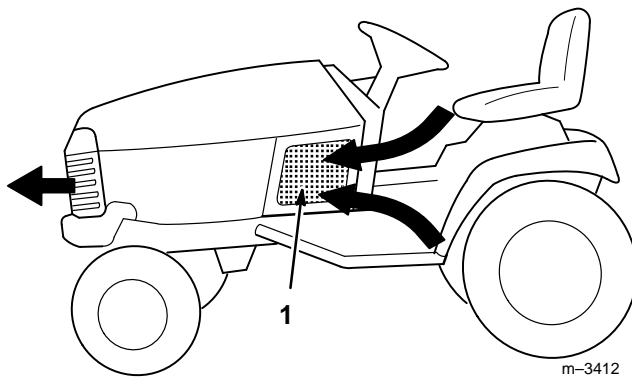

Figure 6

Arrows show air intake and exhaust path

1. Air intake screens (1 of 3 shown)

3. Wipe away any accumulated debris from the rotating air intake screen (Fig. 7).

! **DANGER**

POTENTIAL HAZARD

- Rotating air intake screen and drive shaft can cause injury.

WHAT CAN HAPPEN

- Fingers, hands or loose clothing can get caught by rotating air intake screen and drive shaft.

HOW TO AVOID THE HAZARD

- Do not operate the tractor without the side panels and hood in place.
- Keep fingers, hands and clothing clear of rotating air intake screen and drive shaft.
- Shut off the engine and remove the ignition key before performing maintenance.

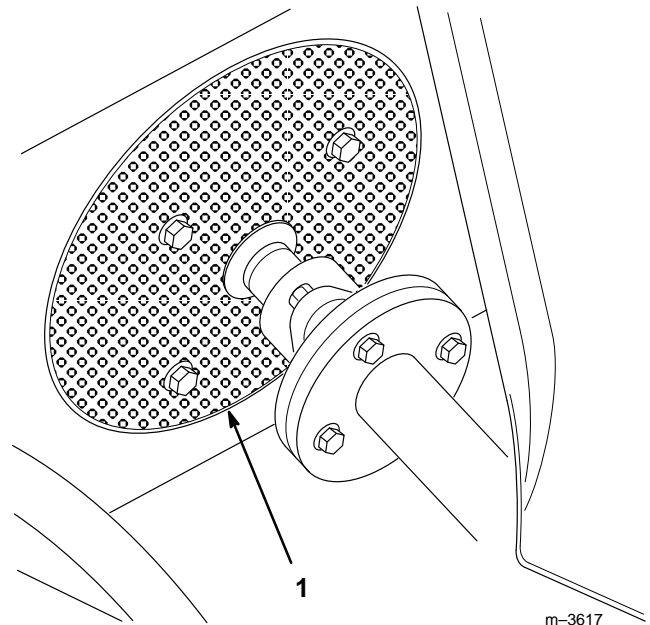
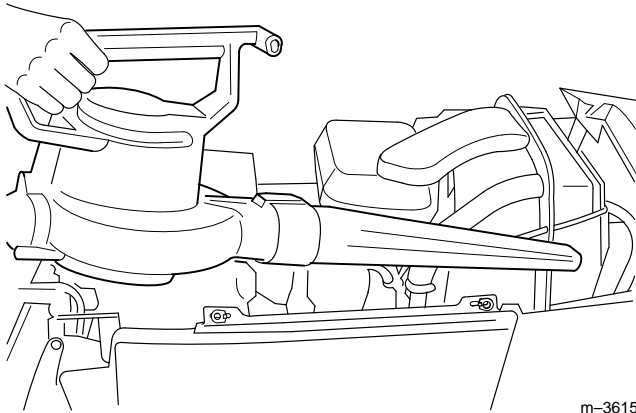

Figure 7

1. Rotating air intake screen

4. Debris can build up in the engine area. Clean any debris build-up with a brush or blower before each use.

IMPORTANT: It is preferable to blow dirt out (Fig. 8), rather than washing it out. If water is used, keep it away from electrical items.



m-3615

Figure 8

IMPORTANT: DO NOT HIGH-PRESSURE WASH. High-pressure washing can damage the electrical system or deplete grease.

5. The rear transaxle cover is an air intake area for cooling the transaxle. Clean debris from the rear transaxle cover before operating the tractor (Fig. 9).

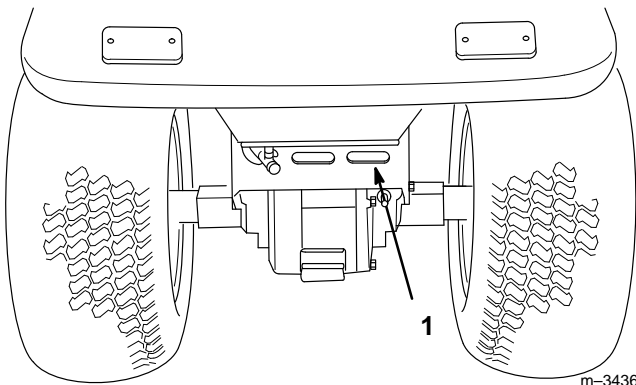

m-3436

Figure 9

1. Rear transaxle cover

Check the Safety Interlock System

Always check the interlock system before operating the tractor. Instructions for checking the interlock system are found in the Operation section, page 21.

Check the Brake

Refer to Checking and Adjusting the Brake, page 36.

Operation

Think Safety First

Please carefully read all the safety instructions on pages 2–7. Knowing this information could help you, your family, pets or bystanders avoid injury.

Controls

Become familiar with all the controls (Fig. 10) before you start the engine and operate the machine.

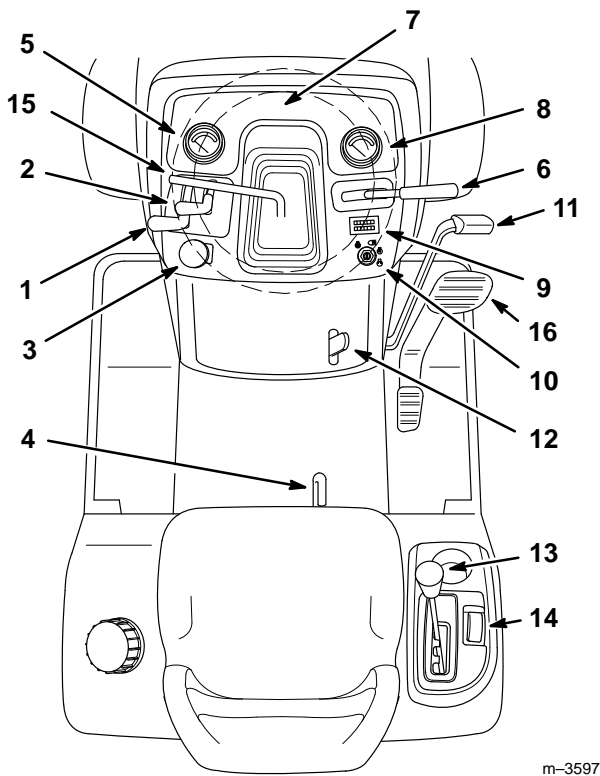

Figure 10

m-3597

- | | |
|-----------------------------------|-------------------------------|
| 1. Throttle | 9. Hour meter |
| 2. Choke | 10. Ignition switch |
| 3. PTO switch | 11. Brake pedal |
| 4. Seat adjustment lever | 12. Parking brake lever |
| 5. Engine water temperature gauge | 13. High-Low range lever |
| 6. Attachment lift lever | 14. Cruise control switch |
| 7. Indicator lights | 15. Steering wheel tilt lever |
| 8. Fuel gauge | 16. Traction control pedal |

“Key Choice” Key

A turn and release key used for deactivating the “Operating-In-Reverse” interlock feature. Located on the seat bracket in front of and just below the seat (Fig. 11).

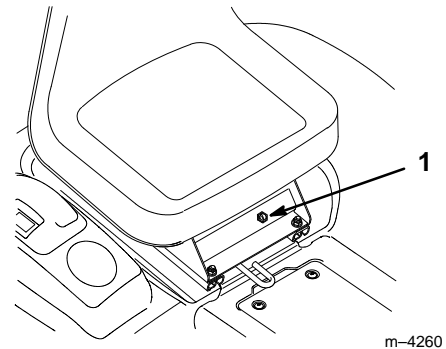

m-4260

Figure 11

1. “Key Choice” key

Parking Brake

Always set the parking brake when you stop the machine or leave it unattended.

Setting the Parking Brake

1. Push the brake pedal (Fig. 10) down and hold it in the depressed position.
2. Lift the parking brake lever (Fig. 10) up and gradually take your foot off the brake pedal. The brake pedal should stay in the depressed (locked) position.

Releasing the Parking Brake

1. Push down on the brake pedal (Fig. 10). The parking brake lever should release.
2. Release the brake pedal.

Starting and Stopping the Engine

Starting

1. Sit down on the seat.
2. Depress the brake pedal.

Note: The engine will not start unless you fully depress the brake pedal.
3. Push the PTO (power take off) switch to OFF (Fig. 12).
4. Move the choke lever to ON (if the engine is cold) (Fig. 12).

5. Move the throttle lever halfway to FAST (Fig. 12).
6. Turn the ignition key clockwise and hold it in the START position (Fig. 13). When the engine starts, release the key.

IMPORTANT: Do not run the starter motor more than 5 seconds at a time or premature starter failure may result. If the engine fails to start after 5 seconds, turn the key to the OFF position, recheck the controls and procedures, wait 10 additional seconds and repeat the starting operation; refer to Troubleshooting, page 50.

7. After the engine starts, gradually move the choke lever to OFF (Fig. 12). If the engine stalls or hesitates, move the choke lever back to ON for a few seconds. Then move the throttle lever to the desired setting.

Note: Allowing the engine to warm up before putting it under load will lengthen engine life.

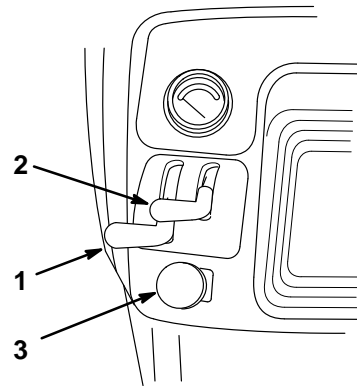

Figure 12

- | | |
|-------------|---------------|
| 1. Throttle | 3. PTO switch |
| 2. Choke | |

m-3257

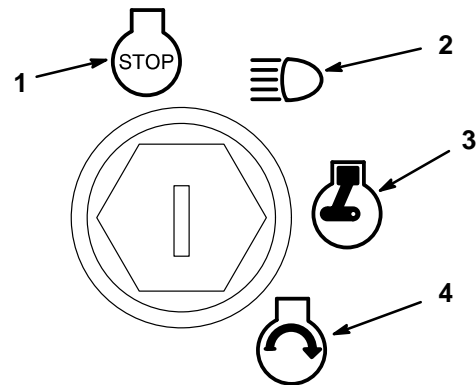

Figure 13

- | | |
|--------------------|----------|
| 1. Stop | 3. Run |
| 2. Run with lights | 4. Start |

m-3312

Stopping

1. Move the throttle lever to SLOW (Fig. 12).
2. Allow the engine to run for a short time to cool down.
3. Turn the ignition key to “STOP” (Fig. 13).
4. Always remove both the ignition and “Key Choice” keys when the equipment is not in use or unattended.

Operating the Power Take Off (PTO)

The power take-off (PTO) switch engages and disengages power to the electric clutch.

If the ignition key is in the RUN or LIGHTS position and the power take off (PTO) is engaged, the PTO indicator light will be on. When this light is on, it is a reminder: the implement is being powered and the starter will not crank while the PTO is engaged. Always turn off the PTO before getting off the seat.

Engaging the Power Take Off (PTO)

1. Depress the brake pedal to stop the machine.
2. Move the throttle lever to FAST.

IMPORTANT: For best performance, always use full throttle when the power take off (PTO) switch is ON.

3. Pull the power take off (PTO) switch to ON (Fig. 14).

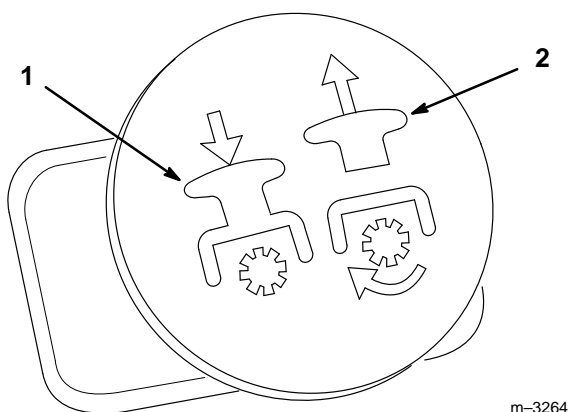

Figure 14

1. Push (off-disengaged)
2. Pull (on-engaged)

Disengaging the Power Take Off (PTO)

1. Push the power take off (PTO) switch to OFF.

The Safety Interlock System

Understanding the Safety Interlock System

The safety interlock system is designed to prevent the engine from starting unless:

- You are sitting on the seat
- The brake pedal is depressed
- The power take off (PTO) is OFF

The safety interlock system is designed to stop the engine if:

- You rise from the seat when the brake pedal is released
- You rise from the seat when the power take off (PTO) is "ON".

The safety interlock system is designed to stop the power take off (PTO) if:

- You shift into reverse with the power take off (PTO) engaged.

Operating-in-Reverse

An interlock feature is provided that prevents the Power Take Off (PTO) from operating while the tractor is traveling in reverse. If the unit is shifted into reverse while the mower blade or other PTO driven attachment is engaged, the PTO will stop.

If you need to mow while in reverse gear or use other PTO driven attachments (such as a snowthrower or tiller), this operating-in-reverse interlock feature may be temporarily deactivated. **Do not mow while backing up unless it is absolutely necessary.**

Before deactivating this feature, be sure there are no children present on or near the property where you are using the tractor, and that none are likely to appear while you are mowing or operating an attachment. Be extra observant after you have chosen to deactivate the interlock feature because the sound of the tractor's engine might prevent you from being aware that a child or a bystander has entered the area where you are operating the tractor.

If you are certain that you can safely mow in reverse or operate an attachment, deactivate the operating-in-reverse interlock feature by turning the "Key Choice" key (Fig. 15), located on the seat bracket in front of and just below the seat, after engaging the blade (PTO). A red light on the front console (Fig. 16) will turn on as a reminder that the operating-in-reverse interlock has been deactivated. Once the interlock is deactivated it stays in this mode—with your mower blade or PTO-driven attachment operating whenever you back up—and the console light stays on until either the blade (PTO) is disengaged, or the engine is turned off.

Note: Do not insert the "Key Choice" key unless it is absolutely necessary to mow in reverse or operate an attachment. The "Key Choice" key should also be removed from the unit if it will be operated by someone other than a responsible, experienced operator. This will prevent the PTO from operating when the tractor is moving in reverse. Always remove both the ignition and the "Key Choice" keys and put them in a safe place out of the reach of children when leaving the unit unattended.

! DANGER

POTENTIAL HAZARD

- A child or bystander could be backed over by a riding mower with its blade(s) engaged.

WHAT CAN HAPPEN

- Blade contact will cause serious personal injury or death.

HOW TO AVOID THE HAZARD

- Do not mow in reverse unless absolutely necessary.
- Always look backward and down before backing up.
- Use "Key Choice" key only if you are certain no children or other bystanders will appear in the mowing area.
- Always remove both the ignition and "Key Choice" keys and put them in a safe place out of the reach of children or unauthorized users when leaving the unit unattended.

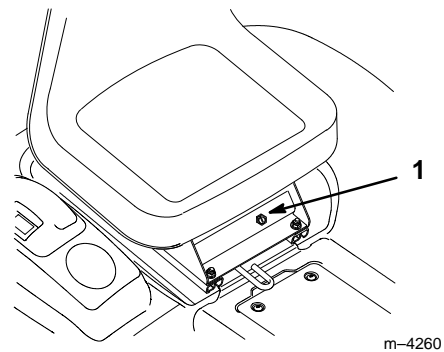

Figure 15

1. "Key Choice" key

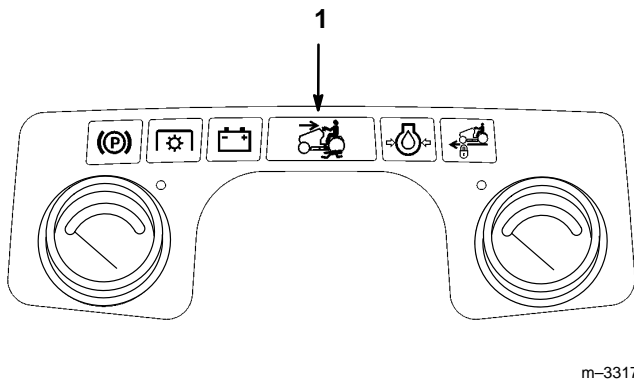

Figure 16

1. Operating-in-Reverse warning light

Testing the Safety Interlock System

Test the safety interlock system each time before you use the machine. Do not operate the machine if the safety system is not functioning properly. If the safety system does not operate as described below, have an Authorized Service Dealer repair the safety system immediately.

1. Fully depress the brake pedal. Pull the power take-off (PTO) switch to ON. Now turn the ignition key to START. The starter should not crank.
2. Push the power take-off (PTO) switch to OFF and release the brake pedal. Now turn the ignition key to START; the starter should not crank.
3. Fully depress the brake pedal and set the parking brake. Push the PTO switch to OFF and rise from the seat. Now turn the ignition key to START. The starter should not crank.
4. Fully depress the brake pedal and set the parking brake. Push the power take-off (PTO) switch to OFF. Now start the engine. While the engine is running, release the parking brake and rise slightly from the seat; the engine should stop.
5. Fully depress the brake pedal, set the parking brake, push the PTO switch to OFF and start the engine. Pull the PTO switch to ON. Rise slightly from the seat; the engine should stop.
6. With the parking brake released, turn the ignition key to RUN without starting the engine. Pull the PTO switch to ON. You should hear an audible click indicating the PTO is activated and the PTO light will illuminate. Move the foot pedal to reverse. You should hear an audible click indicating the PTO is deactivated and the PTO light should turn off.
7. With the parking brake released, turn the ignition switch to RUN without starting the engine. Pull the PTO switch to ON. Turn the "Key Choice" key and release. The Operating-in-Reverse warning light should illuminate. Move the foot pedal to reverse. The PTO and PTO light on the dash should remain on. Push the PTO switch to OFF. The PTO light and the Operating-in-Reverse warning light should turn off.

Gauges and Indicator Lights

The indicator lights (Fig. 17) illuminate when certain controls are activated and when major malfunctions occur that need immediate attention.

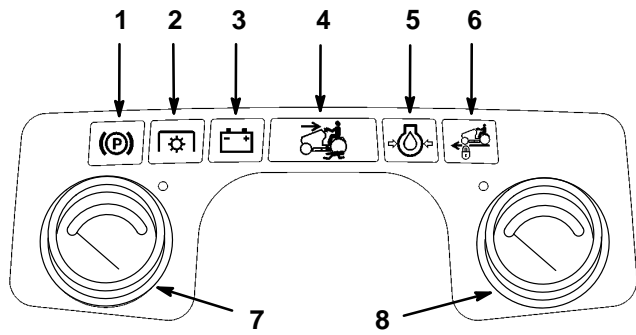

m-3317

Figure 17

- | | |
|---------------------------------------|---------------------------------|
| 1. Parking brake light | 5. Oil pressure light |
| 2. PTO (power take off) light | 6. Cruise control light |
| 3. Battery light | 7. Engine oil temperature gauge |
| 4. Operating-in-Reverse warning light | 8. Fuel gauge |

Parking Brake Light

When the parking brake light is ON it indicates the parking brake is set. The machine will not drive while the parking brake is set.

PTO (Power Take Off) Light

When the PTO (power take off) light is ON it indicates the implement is being powered. The PTO clutch must be disengaged before the engine will start.

Battery Light

The battery light will be ON when the key is in the RUN or LIGHTS positions if the battery voltage is below 12.1 volts or above 15.0 volts. If the light

comes on at a higher RPM, it is important to have your battery and electrical system checked and the problem corrected.

Operating-in-Reverse Warning Light

The Operating-in-Reverse warning light will illuminate whenever the “Key Choice” key is used to deactivate the operating-in-reverse interlock. It is a reminder that the interlock system is deactivated. The light goes out whenever the power take off (PTO) is disengaged or the engine is shut off. **When the light is on, look behind and use extra caution when backing. Be especially watchful for children and pets.**

Oil Pressure Light

When the oil light is ON it indicates the engine oil pressure is low. After the engine starts the light should go out. When the engine is running, the light comes ON if the oil pressure drops below a safe operating level. If the light comes on while the engine is running, **stop the engine immediately and correct the cause of low oil pressure.**

Cruise Control Light

The cruise control light indicates that the cruise control system is activated.

Engine Oil Temperature Gauge

This gauge shows the oil temperature in the engine. If the gauge enters the red zone, disengage the PTO and allow the engine to cool while continuing to run the engine.

If the gauge does not show temperatures dropping, **stop the engine immediately, clean the air intake screens, and/or correct the cause of high temperature.**

Fuel Level Gauge

This gauge shows the level of fuel remaining.

Hour Meter

The hour meter (Fig. 10) records the amount of time the engine has run. Use it to schedule regular maintenance.

Driving Forward or Backward

1. Stop the tractor.

IMPORTANT: Never attempt to shift gears with the tractor in motion. Internal transmission damage may result.

IMPORTANT: Do not force the shift lever. Applying slight pressure to the traction control pedal while shifting will help the gears engage.

2. Shift into high “H” or low “L” forward speed with the High–Low lever (Fig. 10). Use Low for best mowing performance and smoothest operation with all attachments. Use High for transporting or where conditions permit higher speed.

DANGER

POTENTIAL HAZARD

- Excessive speed on slopes can result in rollover accidents or loss of control.

WHAT CAN HAPPEN

- Rollover accidents or loss of control can result in serious injury or death.

HOW TO AVOID THE HAZARD

- Never shift into neutral while moving.
- Never allow tractor to roll freely in neutral on slopes.
- Read, understand, and follow all instructions in the operator’s manual and on the machine before starting.

3. Place the throttle control in the FAST position for best performance. (The throttle control regulates engine revolutions per minute).
4. Place your foot on the traction control pedal and slowly press on the top of the pedal to move forward, or on the bottom of the pedal to move backward (Fig. 18). The farther you move the pedal in either direction, the faster the machine will move in that direction.
5. To slow down, release the pressure on the traction control pedal and step on the brake pedal.

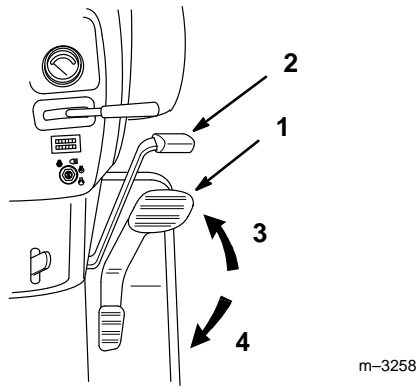

Figure 18

- | | |
|---------------------------|-------------|
| 1. Traction control pedal | 3. Forward |
| 2. Brake pedal | 4. Backward |

Stopping the Machine

To stop the machine, release the traction control pedal, step on the brake pedal, disengage the power take off (PTO), lower the attachment lift, and turn the ignition key to STOP. Also set the parking brake if you leave the machine unattended; refer to Setting the Parking Brake, page 17. Remember to remove both the ignition and “Key Choice” keys from the switches.

CAUTION

POTENTIAL HAZARD

- Someone could move or attempt to operate the tractor while it is unattended.

WHAT CAN HAPPEN

- Children or bystanders may be injured if they use the tractor.

HOW TO AVOID THE HAZARD

- Always remove both the ignition and “Key Choice” keys, and set the parking brake when leaving the machine unattended, even if just for a few minutes.

Attachment Power Lift

The attachment power lift (Fig. 19) is used to raise and lower attachments.

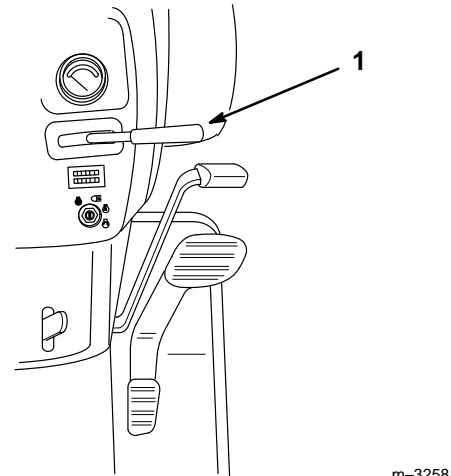

Figure 19

1. Attachment power lift

Raising Attachments

1. Start the tractor.
2. Pull the lift lever UP to raise the attachment (Fig. 20). This will lift and hold the attachment in the raised position.

WARNING

POTENTIAL HAZARD

- When the engine is off, attachments in the raised position can gradually lower.

WHAT CAN HAPPEN

- Someone nearby may be pinned or injured by the attachment as it lowers.

HOW TO AVOID THE HAZARD

- Always lower the attachment lift each time you shut off the tractor.

Lowering Attachments

1. Start the tractor.
2. Push the lift lever **DOWN** to lower the attachment (Fig. 20).

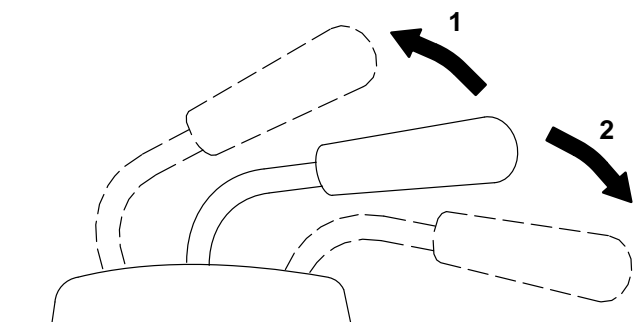

Figure 20

1. Lift lever—Up
2. Lift lever—Down

Positioning the Seat

The seat can move forward and backward. Position the seat where you have the best control of the machine and are most comfortable.

1. To adjust, move the lever sideways to unlock seat (Fig. 21).
2. Slide the seat to the desired position and release the lever to lock the seat into position.

IMPORTANT: Be sure that the seat is locked in position before operating.

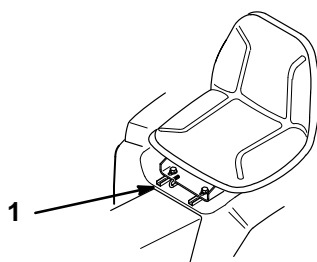

Figure 21

1. Adjustment lever

Headlights and Taillights

The headlights and taillights are turned on by turning the ignition key to the **LIGHTS** position. They can be turned on even if the engine is not running. Remove the ignition key when leaving the machine unattended so that the headlights cannot be turned on and discharge the battery.

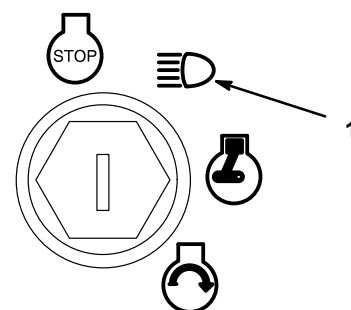

Figure 22

1. Lights

m-3312

Positioning the Tilt Steering Wheel

The steering wheel has four tilt locations. Position the steering wheel where you have the best control of the machine and are most comfortable.

1. Lift the tilt lever to release the lock (Fig. 23).
2. Move the steering wheel to a comfortable position; then release the lever to lock it in place.

m-3320

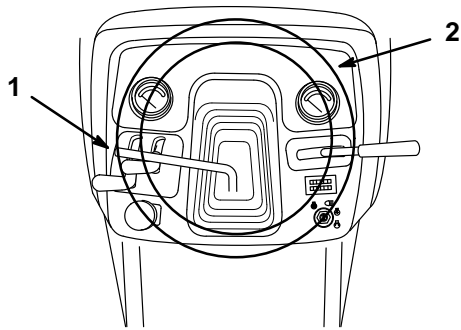

m-3259

Figure 23

1. Tilt lever

2. Steering wheel

Using the Cruise Control

The cruise control is a switch (Fig. 24) on the right fender that maintains a set traction control position without foot pressure. The cruise control only operates when moving forward.

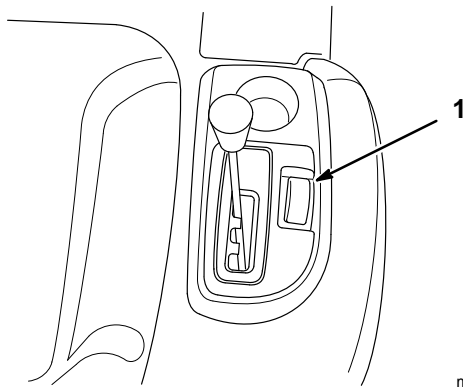

m-3313

Figure 24

1. Cruise control

Engaging the Cruise Control

1. Begin driving the tractor; refer to Driving Forward or Backward, page 23. While holding your foot steady on the traction control pedal, push the cruise control switch (Fig. 24) to the “SET” position. This locks the traction control in position and your foot can then be removed from the traction control. A constant pedal position will be maintained.

2. The cruise control has a “speed-up” feature: If you initially set it to any speed other than full speed, you can speed up with your foot on the traction pedal for as long as you wish. When you release the traction pedal, the pre-selected cruise speed resumes automatically.

Disengaging the Cruise Control

1. While holding your foot steady on the traction control, move the cruise control switch (Fig. 10) to the “OFF” position.
2. This unlocks the traction control. You must now use the traction control to move forward.
3. For quick stops, just press the brake pedal. This automatically disengages the cruise control and applies the brake at the same time.

IMPORTANT: If you accidentally press the cruise control while the engine is running and you are not moving, the machine will subsequently operate at partial speed in forward and will not operate in reverse.

To correct this situation, press the cruise control switch to “OFF,” or press the brake pedal to disengage the cruise control.

The Smart Turn™ Steering Feature

The Smart Turn™ Steering feature automatically lowers the speed of the tractor in tight turns. The decrease in speed is directly proportional to the sharpness of the turn, up to a maximum speed reduction of 40 percent. This allows you to make turns at higher speeds without having to change the speed control position. After the turn, the original speed is automatically restored.

The Smart Turn™ Steering feature does not affect engine speed.

This system was set at the factory and should not need adjustment.

DANGER

POTENTIAL HAZARD

- Excessive speed when turning can result in rollover accidents.

WHAT CAN HAPPEN

- Rollover accidents can result in serious injury or death.

HOW TO AVOID THE HAZARD

- Do not rely on the Smart Turn™ Steering feature to avoid accidents while turning.
- Do not set the cruise control at higher speeds when operating on uneven terrain or slopes.
- Read, understand, and follow all instructions in the operator's manual and on the machine before starting.

To Push the Machine

1. Disengage the power take off (PTO) and turn the ignition key to “STOP” to stop the engine.
2. Move the High–Low range lever to the neutral position “N.” This allows the rear wheels to turn freely.
3. Place the lever back in High or Low after moving the machine, and set the parking brake.

Pushing the Machine by Hand

IMPORTANT: Always push the machine by hand. Never tow the machine because transmission damage may occur.

Maintenance

Service Interval Chart

Service Operation	Each Use	5 Hours	25 Hours	50 Hours	100 Hours	200 Hours	Storage Service
Engine Oil—check level	X						X
Brake—check	X						X
Safety System—check	X						X
(3) Air Intake Screens—clean*	X						X
Engine Area—clean*	X						X
Rear Transaxle Cover—clean*	X						X
Engine Oil—change		Initial			X		X
Engine Air Precleaner—clean*			X				X
Tires—check pressure			X				X
Transaxle—check oil level			X				
Battery—check electrolyte level			X				X
Transaxle—change oil				Initial		X	X
Transaxle—change oil filter				Initial		X	X
Lubrication				X			X
PTO (Power Take Off) Belt—check tension		initial		X			X
Engine Air Filter—replace*					X		X
Fuel Filter—replace					X		X
Engine Oil Filter—change						X	X
Spark Plug(s)—change						X	X
Chipped Surfaces—paint							X
* More often in dusty, dirty conditions							

! CAUTION

POTENTIAL HAZARD

- If you leave the key in the ignition switch, someone could start the engine.

WHAT CAN HAPPEN

- Accidental starting of the engine could seriously injure you or other bystanders.

HOW TO AVOID THE HAZARD

- Remove the key from the ignition switch and pull the wire(s) off the spark plug(s) before you do any maintenance. Also push the wire(s) aside so it does not accidentally contact the spark plug(s).

Air Cleaner

Service Interval/Specification

Foam Element: Clean and re-oil after every 25 operating hours, or yearly, whichever occurs first.

Paper Element: Replace after every 100 operating hours or yearly, whichever occurs first.

Note: Service the air cleaner more frequently (every few hours) if operating conditions are extremely dusty or sandy.

Removing the Foam and Paper Elements

1. Disengage the power take off (PTO), set the parking brake, lower the attachment lift, and turn the ignition key to "STOP" to stop the engine. Remove the ignition key.
2. Open the hood.
3. Clean around the air cleaner to prevent dirt from getting into the engine and causing damage. Unhook the latches and remove the air cleaner cover (Fig. 25).
4. Carefully slide the foam element off the paper element (Fig. 25).
5. Unscrew the cover nut and remove the cover and paper element (Fig. 25).

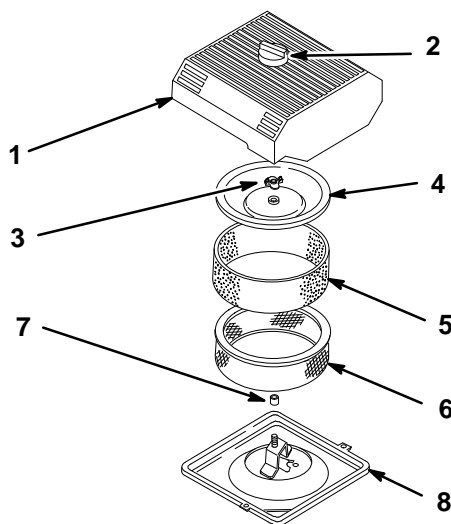

Figure 25

- | | |
|----------------------|---------------------|
| 1. Air cleaner cover | 5. Foam element |
| 2. Knob | 6. Paper element |
| 3. Cover nut | 7. Rubber seal |
| 4. Cover | 8. Air cleaner base |

m-3214

Cleaning the Foam Element

1. Wash the foam element in liquid soap and warm water. When the element is clean, rinse it thoroughly.
2. Dry the element by squeezing it in a clean cloth.
3. Put one or two ounces of oil on the element (Fig. 26). Squeeze the element to distribute the oil.

IMPORTANT: Replace the foam element if it is torn or worn.

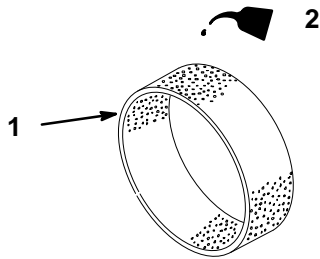

Figure 26

1. Foam element
2. Oil

m-3247

Checking the Paper Element

Inspect the element for tears, an oily film, and damage to the rubber seal (Fig. 27).

IMPORTANT: Never clean the paper element with pressurized air or liquids, such as solvent, gas, or kerosene. Replace the element if it is damaged or cannot be cleaned thoroughly.

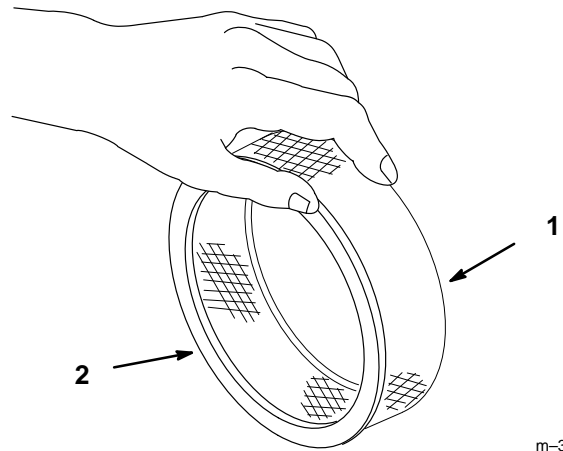

Figure 27

m-3248

1. Paper element
2. Rubber seal

IMPORTANT: To prevent engine damage, always operate the engine with the complete foam and paper air cleaner assembly installed.

Installing the Foam and Paper Elements

1. Carefully slide the foam element onto the paper air cleaner element (Fig. 25).
2. Slide the air cleaner assembly and cover onto the long rod. Now screw the cover nut finger-tight against the cover (Fig. 25).

Note: Make sure the rubber seal is flat against the air cleaner base and cover.

3. Install the air cleaner cover and hook latches (Fig. 25).
4. Close the hood.

Engine Oil

Service Interval/Specification

Change oil:

- After the first 5 operating hours.
- After every 100 operating hours.

Oil Type: Detergent oil (API service SG or SH)

Crankcase Capacity: w/filter, 2.1 qts. (2.0 l)

Viscosity: See the table below.

USE THESE SAE VISCOSITY OILS

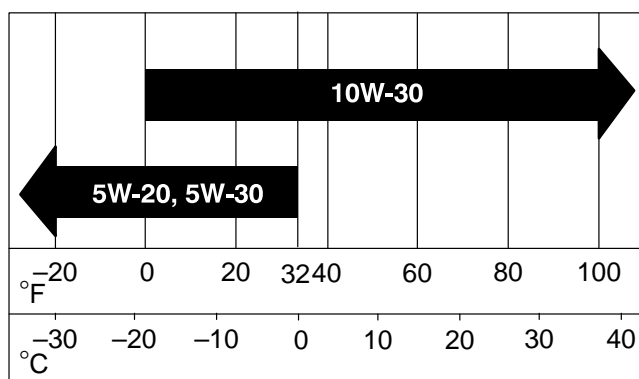

Changing/Draining the Engine Oil

1. Start the engine and let it run for five minutes. This warms the oil so it drains better.
2. Park the machine so that the drain side is slightly lower than the opposite side to assure the oil drains completely. Then disengage the power take off (PTO), set the parking brake, lower the attachment lift, and turn the ignition key to “STOP” to stop the engine. Remove the ignition key.
3. Open the hood.

⚠ CAUTION

POTENTIAL HAZARD

- Components under the hood will be hot if the tractor has been running.

WHAT CAN HAPPEN

- Touching hot components can cause burns.

HOW TO AVOID THE HAZARD

- Allow the tractor to cool before performing maintenance or touching components under the hood.

4. Place a pan below the oil drain. Open the drain by turning it counterclockwise 1/8 turn and pulling out on it (Fig. 28).
5. When the oil has drained completely, close the drain by pushing it in and turning it clockwise, 1/8 turn.

Note: Dispose of the used oil at a certified recycling center.
6. Slowly pour approximately 80% of the specified amount of oil into the oil filler tube (Fig. 30). Now check the oil level; refer to Checking the Engine Oil Level, page 14. Slowly add additional oil to bring the oil level to the FULL mark on the dipstick.

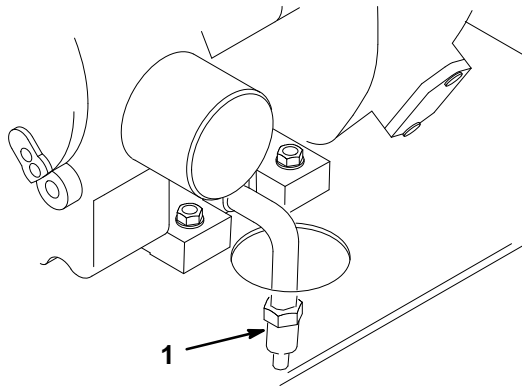

Figure 28

1. Oil drain

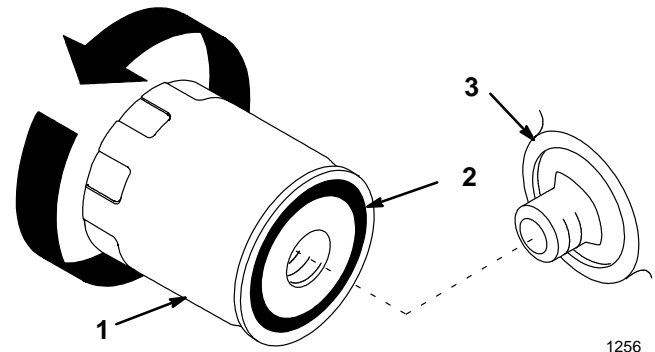

Figure 29

1. Oil filter
2. Gasket
3. Adapter

IMPORTANT: Overfilling the crankcase with oil may cause engine damage.

Changing the Engine Oil Filter

Service Interval/Specification

Replace the oil filter every 200 hours of operation or every other oil change.

1. Drain the oil from the engine; refer to Changing/Draining Oil, page 31.
2. Remove the old filter and wipe the filter adapter (Fig. 29) gasket surface.
3. Apply a thin coat of new oil to the rubber gasket on the replacement filter (Fig. 29).

4. Install the replacement oil filter to the filter adapter. Turn the oil filter clockwise until the rubber gasket contacts the filter adapter, then tighten the filter an additional 1/2 turn (Fig. 29).
5. Fill the crankcase with the correct type of new oil; refer to Changing/Draining Oil, page 31.

Note: Dispose of the oil filter properly. Recycle in accordance with local codes.

Spark Plugs

Service Interval/Specification

Change the spark plugs after every 200 operating hours. Make sure the air gap between the center and side electrodes is correct before installing the spark plugs. Use a spark plug wrench for removing and installing the spark plugs and a gapping tool/feeler gauge to check and adjust the air gap.

Type: Champion RC-12YC (or equivalent)

Air Gap: 0.030" (0.76 mm)

Removing the Spark Plug

1. Disengage the power take off (PTO), set the parking brake, lower the attachment lift, and turn the ignition key to "STOP" to stop the engine. Remove the ignition key.
2. Open the hood.
3. Pull the wire(s) off the spark plug(s) (Fig. 30). Now clean around the spark plug(s) to prevent dirt from falling into the engine and potentially causing damage.

4. Remove the spark plug(s) and metal washer.

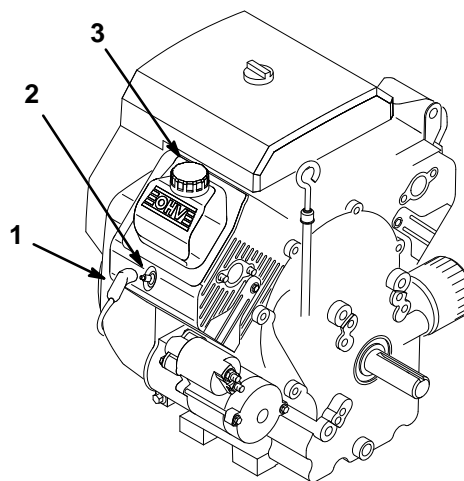

m-3246

Figure 30

- | | |
|--------------------|---------------|
| 1. Spark plug wire | 3. Oil filler |
| 2. Spark plug | |

Checking the Spark Plugs

1. Look at the center of the spark plug(s) (Fig. 31). If you see light brown or gray on the insulator, the engine is operating properly. A black coating on the insulator usually means the air cleaner is dirty.

IMPORTANT: Never clean the spark plug(s). Always replace the spark plug(s) when it has: a black coating, worn electrodes, an oily film, or cracks.

2. Check the gap between the center and side electrodes (Fig. 31). Bend the side electrode (Fig. 31) if the gap is not correct.

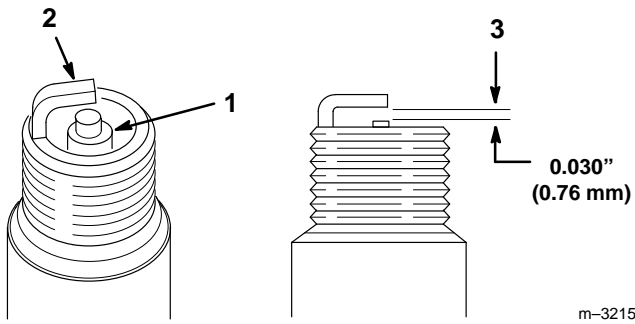

Figure 31

1. Center electrode insulator 3. Air gap (not to scale)
2. Side electrode

m-3215

3. Connect a grease gun to the fitting. Pump grease into the fittings until grease begins to ooze out of the bearings.
4. Wipe up any excess grease.

Where to Add Grease

1. Lubricate the left-hand and right-hand spindles until grease begins to ooze out of the bearings (Fig. 32).
2. Lubricate the front axle pivot (Fig. 32).

Installing the Spark Plugs

1. Install the spark plugs and metal washer. Make sure the air gap is set correctly.
2. Tighten the spark plugs to 18/22 ft-lb (24.4/29.8 Nm).
3. Push the wires onto the spark plugs (Fig. 30).
4. Close the hood.

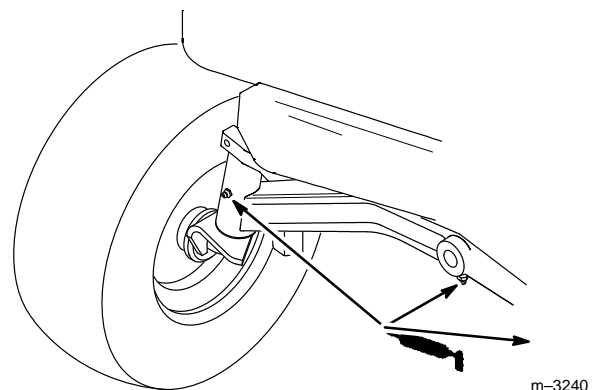

Figure 32

m-3240

Greasing and Lubrication

Service Interval/Specification

Grease the machine after every 50 operating hours or yearly, whichever occurs first. Grease more frequently when operating conditions are extremely dusty or sandy.

Grease Type: General-purpose grease.

How to Grease

1. Disengage the power take off (PTO), set the parking brake, lower the attachment lift, and turn the ignition key to "STOP" to stop the engine. Remove the ignition key.
2. Clean the grease fittings with a cloth. Make sure to scrape off any paint from the front of the fitting(s).

3. Open the drive shaft maintenance cover on the tractor tunnel near the seat by unscrewing the two screws securing it, then raising it (Fig. 33).

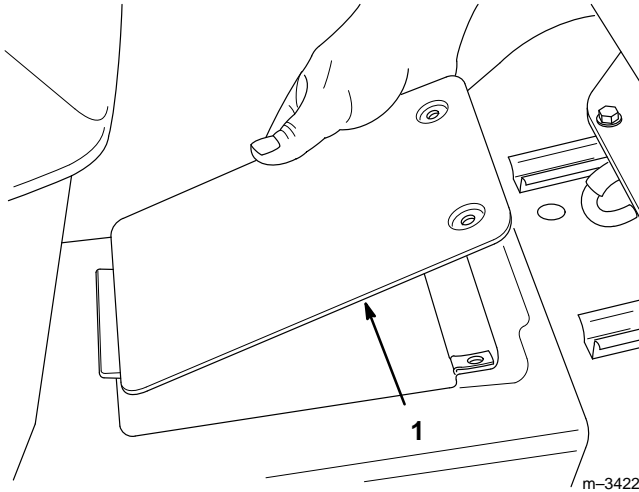

Figure 33

1. Drive shaft maintenance cover

4. Lubricate the three grease fittings (Fig. 34)

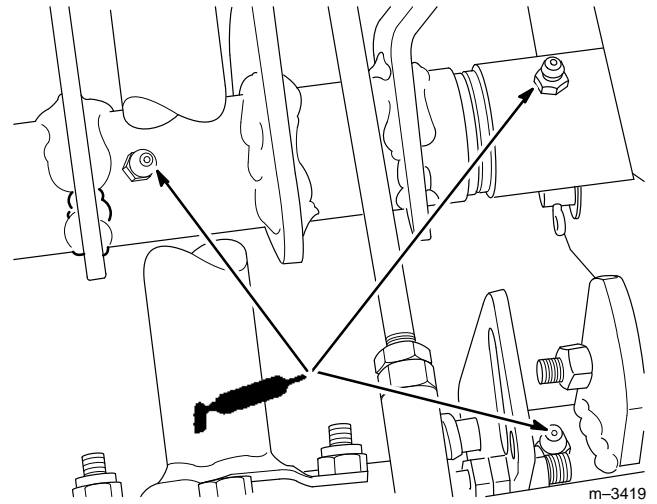

Figure 34

! DANGER

POTENTIAL HAZARD

- Rotating shaft or cooling fan can cause injury.

WHAT CAN HAPPEN

- Fingers, hands, feet, hair, etc. can get caught by shaft or fan.
- Loose clothing can get caught by shaft.

HOW TO AVOID THE HAZARD

- Do not operate the tractor without the drive shaft cover in place.
- Keep hands and arms clear of rotating shaft or fan.

).

5. Replace and secure the cover.
6. Grease the fitting on the brake pedal (Fig. 35).

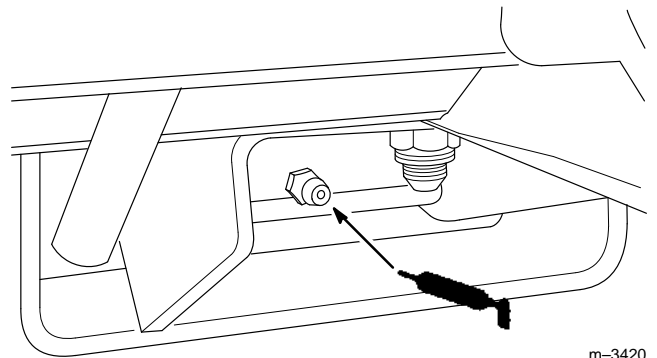

Figure 35

7. Put one pump of grease into the steering housing (from underneath the frame) (Fig. 36) every 50 hours.

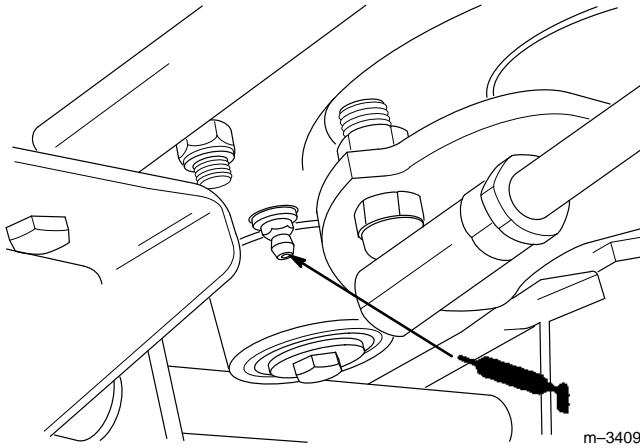

Figure 36

Tire Pressure

Service Interval/Specification

Maintain the air pressure in the front and rear tires as specified. Check the pressure at the valve stem after every 25 operating hours or monthly, whichever occurs first (Fig. 37). Check the tires when they are cold to get the most accurate pressure reading.

Pressure: 20 psi (138 kPa) front and rear

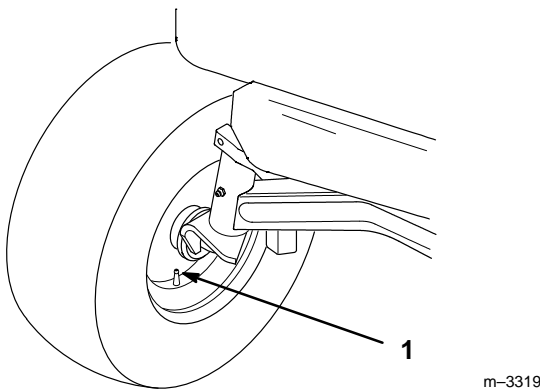

Figure 37

1. Valve stem

Brake

Always set the parking brake when you stop the machine or leave it unattended. Check the brake before each use. If the parking brake does not hold securely, an adjustment is required.

Checking the Brake

1. Park the machine on a level surface, disengage the power take off (PTO), put the High-Low range lever in “N,” set the parking brake, and turn the ignition key to “STOP” to stop the engine. Remove the ignition key.
2. The rear wheels must lock and skid when you try to push the tractor forward. Adjustment is required if the wheels turn and do not lock; refer to Adjusting the Brake.

Adjusting the Brake

The brake adjustment is at the rear of the tractor (Fig. 39). If the parking brake does not hold securely, an adjustment is required.

1. Check the brake before you adjust it; refer to Checking the Brake.
2. Place the transmission in neutral.
3. Depress the brake pedal. There should be 2” (51 mm) of free travel (Fig. 38) before the brake begins to engage.

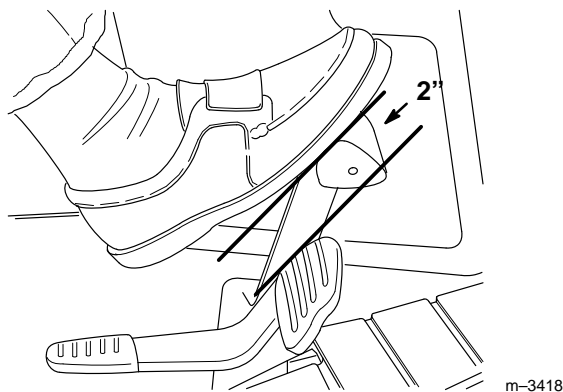

Figure 38

- Turn the brake adjustment nut (Fig. 39) until there is 2" (51 mm) of free travel.

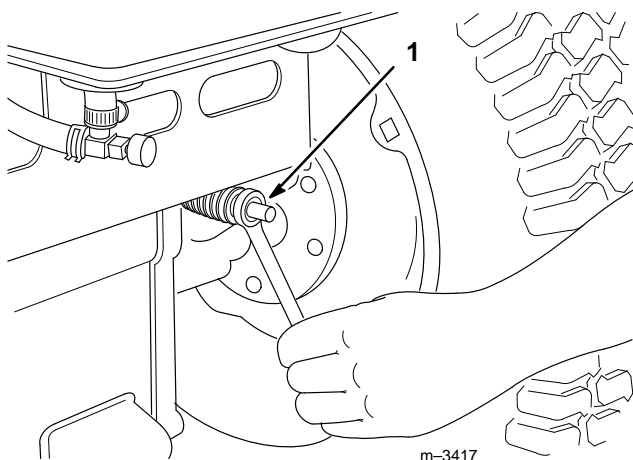

Figure 39

- Brake adjustment nut

IMPORTANT: Do not overtighten the adjustment nut.

IMPORTANT: With the parking brake released, the rear wheels must rotate freely when you push the tractor. If brake action and free wheel rotation cannot be achieved, contact your Authorized Service Dealer immediately.

Fuel Tank

Draining The Fuel Tank

! DANGER

POTENTIAL HAZARD

- In certain conditions gasoline is extremely flammable and highly explosive.

WHAT CAN HAPPEN

- A fire or explosion from gasoline can burn you, others, and cause property damage.

HOW TO AVOID THE HAZARD

- Drain gasoline from the fuel tank when the engine is cold. Do this outdoors in an open area. Wipe up any gasoline that spills.
- Never drain gasoline near an open flame or where gasoline fumes may be ignited by a spark.
- Never smoke a cigarette, cigar or pipe near the tractor.

- Park the machine on a level surface to assure the fuel tank drains completely. Then disengage the power take off (PTO), set the parking brake, lower the attachment lift, and turn the ignition key to "STOP" to stop the engine. Remove the ignition key.
- Close the fuel shut-off valve at the fuel tank (Fig. 40 & 41).

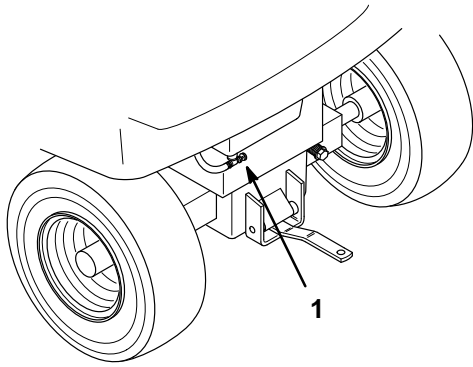

m-3263

Figure 40

1. Fuel shut-off valve

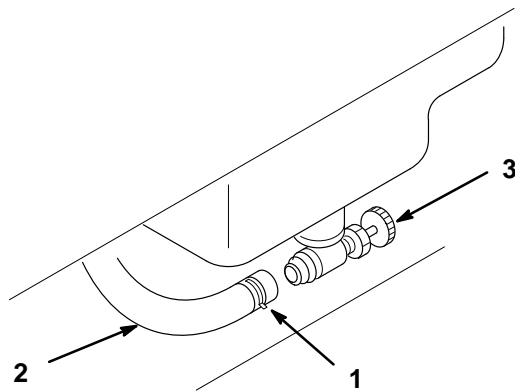

m-2487

Figure 41

1. Hose clamp
2. Fuel line
3. Fuel shut-off valve

3. Loosen the hose clamp and slide it up the fuel line away from the fuel shut-off valve (Fig. 41).
4. Pull the fuel line off the fuel shut-off valve (Fig. 41). Some fuel will flow out from the hose as it is disconnected from the valve. Attach a 5/16 ID hose to the valve to help drain the fuel into the container. Open the valve and allow gasoline to drain into a gas can or drain pan.

IMPORTANT: Do not turn or unscrew the fuel shut-off valve.

5. Install the fuel line onto the fuel shut-off valve. Slide the hose clamp close to the valve to secure the fuel line (Fig. 41). The fuel shut-off valve

should normally be left open, except for service on the fuel system or when the tractor is transported on a trailer.

Fuel Filter

Service Interval/Specification

Replace the fuel filter after every 100 operating hours.

Replacing the Fuel Filter

1. Disengage the power take off (PTO), set the parking brake, lower the attachment lift, and turn the ignition key to "STOP" to stop the engine. Remove the ignition key.
2. Close the fuel shut-off valve at the fuel tank (Fig. 40 & 41).
3. Open the hood and remove the side panels.
4. Squeeze the ends of the hose clamps together and slide them away from the filter (Fig. 42).
5. Remove the filter from the fuel lines.

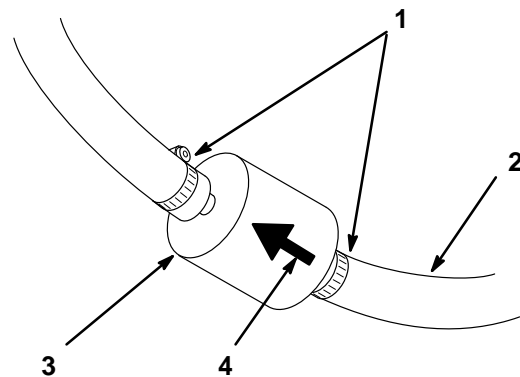

m-3365

Figure 42

1. Hose clamp
2. Fuel line
3. Filter
4. Flow direction arrow

6. Install a new filter and move the hose clamps close to the filter. Make sure the flow direction arrow points toward the engine.

7. Open the fuel shut-off valve at the fuel tank (Fig. 40 & 41).
8. Replace the side panels and close the hood.

Front Wheel Toe-In

Service Interval/Specification

Maintaining correct front wheel toe-in is important for safety, Smart Turn™ Steering operation, and ease of use. If uneven tire wear, lawn scuffing, or hard steering develop, adjustment may be required. Check the toe-in after every 100 operating hours or once a year, whichever occurs first (Fig. 43).

Maintain the following specification: 1/8–1/4 inch (3.5–6.5 mm) toe-in on the front wheels.

Measuring Toe-In

1. Disengage the power take off (PTO), set the parking brake, lower the attachment lift, and turn the ignition key to “STOP” to stop the engine. Remove the ignition key.
2. Turn the wheels straight ahead.
3. Push the front of the tires out to remove normal looseness in the linkage.
4. Measure the distance between both of the front tires at spindle level (at the front and rear of the wheels) (Fig. 43).
5. The front measurement should be 1/8” to 1/4” (3 to 6 mm) less than the rear measurement. If adjustment is needed, follow the instructions in Adjusting Toe-In, page 39.

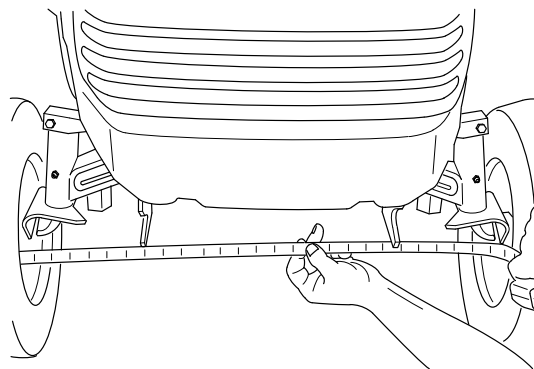

m-3421

Figure 43

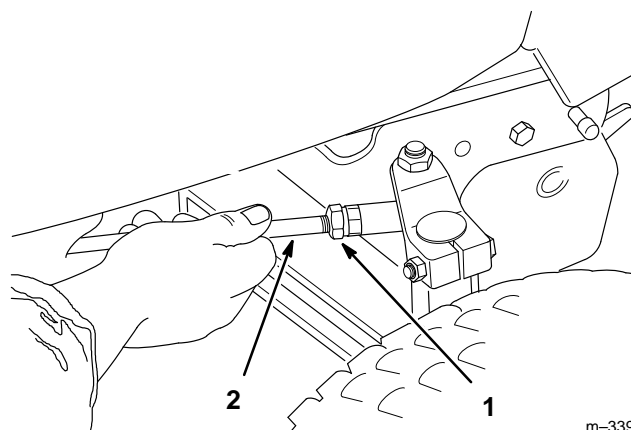

m-3397

Figure 44

1. Jam nut
2. Steering rod

Adjusting Toe-In

1. Loosen the jam nuts at the ends of the steering rods (Fig. 44).
2. Rotate both steering rods equal amounts to adjust the toe-in to 1/8” to 1/4” (3 to 6 mm).
3. Hold each tie rod end with one wrench and tighten the jam nut with a second wrench.

Transaxle Fluid

Service Interval/Specification

Check the fluid level every 25 hours. Always keep the fluid level in the correct operating range on the dipstick when the transaxle is cold.

Fluid Type: SAE 10W–30 Detergent oil (API service SG, SH or above)

Checking the Fluid Level

1. Park the machine on a level surface.
2. Disengage the power take off (PTO), set the parking brake, lower the attachment lift, and turn the ignition key to “STOP” to stop the engine. Remove the ignition key.
3. Tilt the seat up.
4. Clean around the transmission dipstick (Fig. 46) so dirt cannot fall into the filler hole and damage the transaxle.

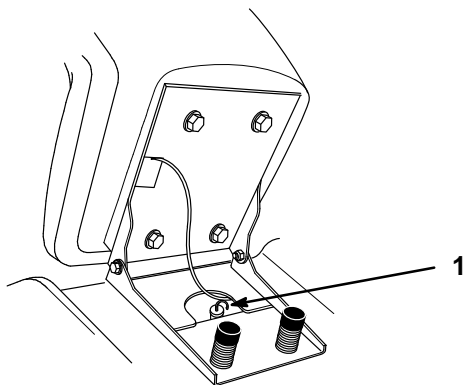

Figure 46

1. Transmission dipstick and filler tube

5. Pull out the transmission dipstick and wipe the metal end clean (Fig. 46).

6. Slide the dipstick fully into the filler tube (Fig. 5). Pull the dipstick out and look at the metal end. When the transaxle is cold, oil should be in the operating range, below the FULL line on the dipstick (Fig. 47).
7. If the oil level is low, slowly pour only enough SAE 10W–30 detergent oil into the filler tube to raise the level to the FULL line.

IMPORTANT: Do not fill above the FULL line as fluid may overflow.

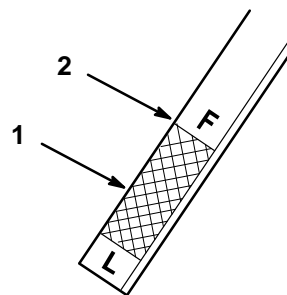

Figure 47

1. Operating range
2. FULL line

m-2467

Changing Transaxle Oil

Replace the transaxle fluid at 50 hours initially, then every 200 hours thereafter.

Fluid Type: SAE 10W–30 Detergent oil (API service SG, SH or above)

Transaxle Capacity:

Total system capacity: 6.0 qts.
Approximate refill capacity: 4.5 qts.

1. Warm up the transaxle oil by driving the tractor.
2. Park the machine on a level surface to assure the oil drains completely. Then turn off the power take off (PTO), set the parking brake, lower the

attachment lift, and turn the ignition key to “STOP” to stop the engine. Remove the ignition key.

3. Place a pan below the transaxle drain. Open the drain by removing the plug (Fig. 48).
4. When the oil has drained completely, wipe clean. Apply pipe sealant to the plug and reinstall.

Note: Dispose of the used oil at a certified recycling center.

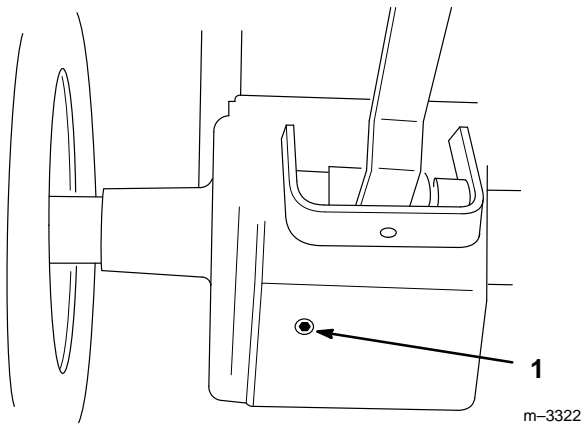

Figure 48

1. Transaxle drain plug
-

5. Change the transaxle filter; refer to Changing the Transaxle Filter, page 42.
6. Slowly pour the specified refill capacity of oil into the filler tube (Fig. 46).
7. Start the engine and let it run for 30 seconds at high idle. Then shut off the engine.
8. Now check the fluid level; refer to Checking Transaxle Fluid Level, page 41. Slowly add additional oil to bring the oil level to the FULL mark on the dipstick.

Changing the Transaxle Filter

Service Interval/Specification

Replace the transaxle filter after the first 50 hours; then every 200 hours.

1. Drain the oil from the transaxle; refer to Changing/Draining Transaxle Fluid, page 41.
2. Remove the transaxle filter and wipe the filter adapter (Fig. 49) gasket surface.
3. Apply a thin coat of new oil to the rubber gasket on the replacement filter (Fig. 49).

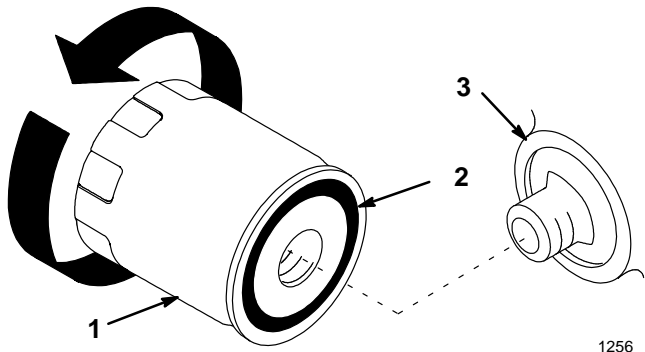

Figure 49

1. Transaxle filter
 2. Gasket
 3. Adapter
-

4. Install the replacement transaxle filter to the filter adapter. Turn the filter clockwise until the rubber gasket contacts the filter adapter, then tighten the filter an additional 3/4 turn (Fig. 49).
5. Fill the transaxle with the proper type of new oil; refer to Changing/Draining Transaxle Fluid, page 41.

Fuses

Service Interval/Specification

The electrical system is protected by fuses. They require no maintenance. However, if a fuse blows, check the component and circuit for a malfunction or short. To replace a fuse, pull it out of the fuse box (Fig. 50).

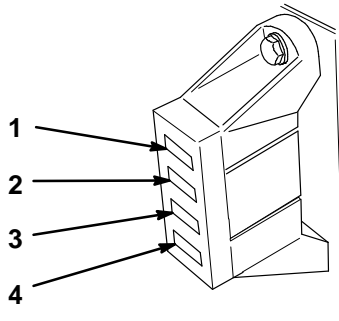

Figure 50

- | | |
|---|---|
| 1. F1; main—30 amp | 4. F4; headlights and taillights—10 amp |
| 2. F2; regulator—25 amp | |
| 3. F3; dash, interlock, and cruise control—10 amp | |

m-3316

Headlights

Specification: Bulb # 1156 Automotive Type

Removing the Bulb

1. Disengage the power take off (PTO), set the parking brake, lower the attachment lift, and turn the ignition key to “STOP” to stop the engine. Remove the ignition key.
2. Open the hood. Pull the wire connectors off both bulb holder terminals.
3. Rotate the bulb holder 1/4 turn counterclockwise and remove it from the reflector (Fig. 51).
4. Push and rotate the bulb counterclockwise until it stops (approx. 1/4 turn) and remove the bulb from the bulb holder (Fig. 52).

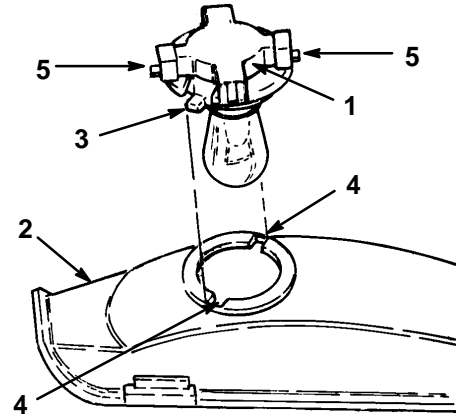

Figure 51

- | | |
|----------------|--------------|
| 1. Bulb holder | 4. Slots |
| 2. Reflector | 5. Terminals |
| 3. Tabs | |

Installing the Bulb

1. The bulb has metal pins on the side of its base. Align the pins with the slots in the bulb holder and insert the base into the holder (Fig. 52). Push and rotate the bulb clockwise until it stops.

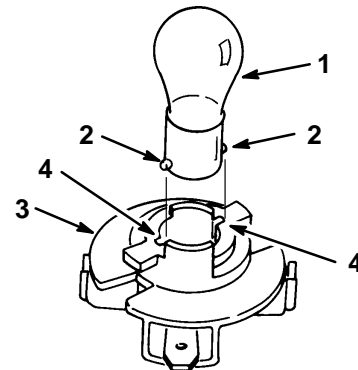

Figure 52

- | | |
|---------------|----------------|
| 1. Bulb | 3. Bulb holder |
| 2. Metal pins | 4. Slots |

2. The bulb holder has two tabs (Fig. 51). Align the tabs with the slots in the reflector, insert the bulb holder into the reflector and rotate it 1/4 turn clockwise until it stops.
3. Push the wire connectors onto the terminals on the bulb holder.

Taillights

Bulb: GE 194

Removing the Bulb

1. Disengage the power take off (PTO), set the parking brake, lower the attachment lift, and turn the ignition key to “STOP” to stop the engine. Remove the ignition key.
2. Remove the two screws.
3. Pull the lens out far enough so that you can remove the bulb socket.
4. Pull the bulb from the socket.

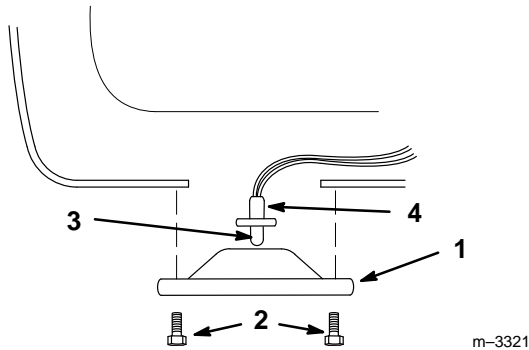

Figure 53

- | | |
|-----------|-----------|
| 1. Lens | 3. Bulb |
| 2. Screws | 4. Socket |

Installing the Bulb

Reverse the bulb removal procedure.

Battery

Service Interval/Specification

Check the electrolyte level in the battery every 25 hours. Always keep the battery clean and fully charged. Use a paper towel to clean the battery case. If the battery terminals are corroded, clean them with a solution of four parts water and one part baking soda. Apply a light coating of grease to the battery terminals to prevent corrosion.

Battery size: 12 v, 380 Cold Cranking Amps

Checking the Electrolyte Level

1. Park the machine on a level surface. Disengage the power take off (PTO), set the parking brake, lower the attachment lift, and turn the ignition key to “STOP” to stop the engine. Remove the ignition key.
2. Remove the tractor’s front grille by raising the hood and unscrewing the two screws and washers securing it in place (Fig. 54). Close the hood and remove the grille by pulling it out toward you.

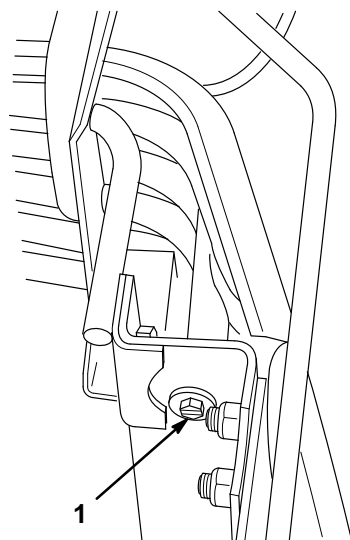

Figure 54

m-3558

1. Grille screw (1 of 2)

3. Remove the battery shield.
4. Open the cell covers to see into the cells. The electrolyte must be up to the lower part of the tube (Fig. 55). Do not allow the electrolyte to get below the plates.
5. If the electrolyte is low, add the required amount of distilled water; refer to Adding Water to the Battery.
6. If the fluid level is correct, press the cell covers onto the battery and replace the battery shield.

IMPORTANT: Keep the battery shield in place to protect the battery from heat.

7. Replace the front grille of the tractor, securing it with the two previously removed screws and washers (Fig. 54).

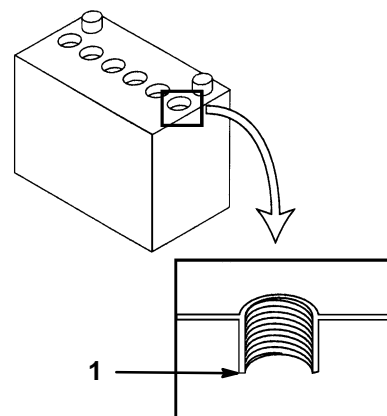

Figure 55

1. Lower part of the battery cell tube

Adding Water to the Battery

IMPORTANT: Use only distilled water.

The best time to add distilled water to the battery is just before you operate the machine. This lets the water mix thoroughly with the electrolyte solution.

1. Clean the top of the battery with a paper towel.
2. Lift off the filler caps (Fig. 55).
3. Slowly pour distilled water into each battery cell until the level is up to the lower part of the tube (Fig. 55).

IMPORTANT: Do not overfill the battery because electrolyte (sulfuric acid) can cause severe corrosion and damage to the chassis.

4. Press the cell covers onto the battery.
5. Replace the battery shield.

IMPORTANT: Keep the battery shield in place to protect the battery from heat.

6. Replace the front grille of the tractor, securing it with the two previously removed screws and washers (Fig. 54).

Removing the Battery

1. Disengage the power take off (PTO), set the parking brake, lower the attachment lift, and turn the ignition key to “STOP” to stop the engine. Remove the ignition key.
2. Remove the tractor’s front grill by raising the hood and unscrewing the two screws and washers securing it in place (Fig. 54). Close the hood and remove the grille by pulling it out toward you.
3. Remove the battery shield (Fig. 56).

IMPORTANT: Always disconnect the negative (black) cable first.

4. Disconnect the negative (black) ground cable from the battery post (Fig. 56).
5. Disconnect the positive (red) cable from the battery post (Fig. 56).
6. Remove the battery by lifting it up, then pulling it out (directly toward you) from the tractor.

IMPORTANT: Always hold the battery vertical to avoid spilling battery acid.

WARNING

POTENTIAL HAZARD

- Either the battery terminals or metal tools could short against metal tractor components.
- Incorrect battery cable routing could damage the cables.

WHAT CAN HAPPEN

- Sparks can cause the battery gasses to explode.
- Damaged cables could short against metal tractor components and cause sparks.

HOW TO AVOID THE HAZARD

- When removing or installing the battery, do not allow the battery terminals to touch any metal parts of the tractor (below the headlights).
- Always **DISCONNECT** the negative (black) battery cable before disconnecting the positive (red) cable.
- Always **RECONNECT** the positive (red) battery cable before reconnecting the negative (black) cable .
- Do not allow metal tools to short between the battery terminals and metal parts of the tractor.
- Always keep the battery shield and hold-down rods in place to protect and secure the battery.
- Always route battery cables as illustrated.

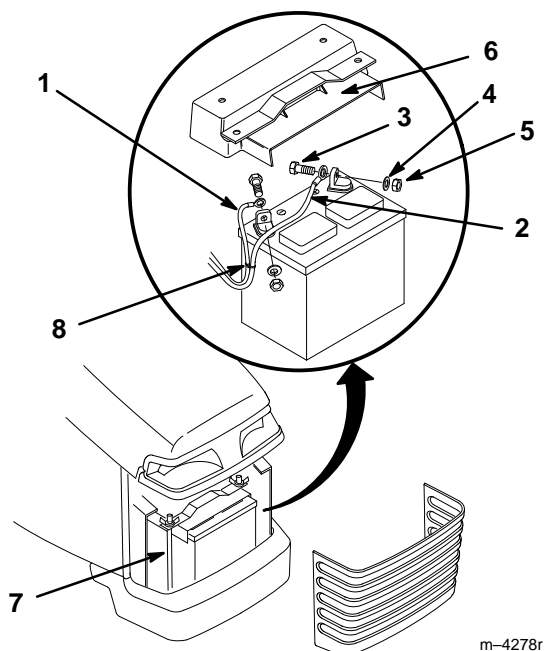

Figure 56

- | | |
|---------------------------|-------------------|
| 1. Negative cable (black) | 5. Locknut (2) |
| 2. Positive cable (red) | 6. Battery shield |
| 3. Bolt (2) | 7. Hold-down rod |
| 4. Washer (2) | 8. Wire tie |

Installing the Battery

1. Place the battery onto the chassis (Fig. 56).

IMPORTANT: Always connect the positive (red) cable first.

2. Using the bolt, washer and locknut, connect the positive (red) cable to the positive (+) battery post (Fig. 56).
3. Using the bolt, washer and locknut, connect the negative (black) cable to the negative (-) battery post (Fig. 56).
4. Replace the battery shield and secure to the chassis with hold-down rods and wing nuts (Fig. 56).

IMPORTANT: Keep the battery shield in place to protect the battery from heat.

5. Replace the front grille of the tractor, securing it with the two previously removed screws and washers (Fig. 54).

Charging the Battery

IMPORTANT: Always keep the battery fully charged (1.260 specific gravity). This is especially important to prevent battery damage when the temperature is below 32°F (0°C).

1. Remove the battery from the chassis; refer to Removing the Battery, page 46.
2. Check the electrolyte level; refer to Checking the Electrolyte Level, page 44, steps 2–5.
3. Remove the cell covers from the battery and connect a 3- to 4-amp battery charger to the battery posts. Charge the battery at a rate of 4 amperes or less for 4 hours (12 volts). Do not overcharge the battery. Install the cell covers after the battery is fully charged.

WARNING

POTENTIAL HAZARD

- Charging the battery produces gasses.

WHAT CAN HAPPEN

- Battery gasses can explode.

HOW TO AVOID THE HAZARD

- Keep cigarettes, sparks and flames away from battery.

4. Install the battery in the chassis; refer to Installing the Battery, page 47.

Wiring Diagram

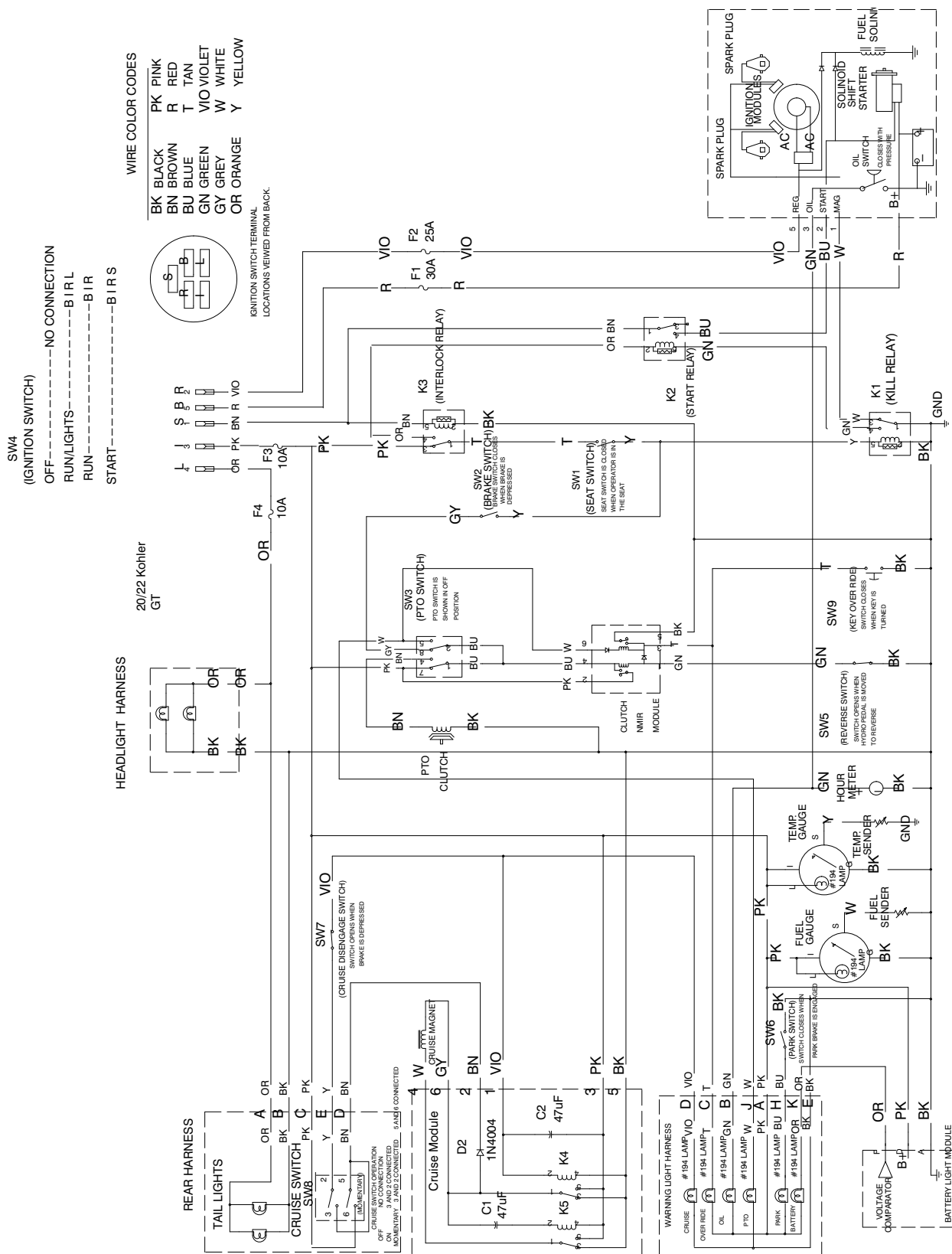

Cleaning and Storage

1. Disengage the power take off (PTO), set the parking brake, and turn the ignition key to “STOP” to stop the engine. Remove the ignition and “Key Choice” keys.
2. Remove grass clippings, dirt, and grime from the external parts of the entire machine, especially the engine. Clean dirt and chaff from the outside of the engine’s cylinder head fins and blower housing; refer to Check for Debris, page 15.

IMPORTANT: You can wash the machine with mild detergent and water. DO NOT PRESSURE WASH THE MACHINE. Pressure washing may damage the electrical system or wash away necessary grease at friction points. Avoid excessive use of water, especially near the control panel, lights, engine, and the battery.

3. Check the brake; refer to Brake, page 36.
4. Service the air cleaner; refer to Air Cleaner, page 29.
5. Grease the chassis; refer to Greasing and Lubrication, page 34.
6. Change the crankcase oil; refer to Engine Oil, page 31.
7. Remove the spark plug(s) and check its condition; refer to Spark Plug, page 33. With the spark plug(s) removed from the engine, pour two tablespoons of engine oil into the spark plug hole. Now use the electric starter to crank the engine and distribute the oil inside the cylinder. Install the spark plug(s) and tighten to recommended torque; refer to Spark Plugs, page 33. Do not install the wire on the spark plug(s).
8. Remove the battery from the chassis, check the electrolyte level, and charge it fully; refer to Battery, page 44. Do not connect the battery cables to the battery posts during storage.

IMPORTANT: The battery must be fully charged to prevent it from freezing and being damaged at temperatures below 32°F (0°C). A fully charged battery maintains its charge for about 50 days at temperatures lower than 40°F (4°C). If the temperatures will be above 40°F (4°C), check the water level in the battery and charge it every 30 days.
9. Check the tire pressure; refer to Tire Pressure, page 36.
10. For long-term storage (more than 90 days) add stabilizer/conditioner additive to fuel in the tank (1 oz. per gallon) (8 ml per liter).
 - A. Run the engine to distribute conditioned fuel through the fuel system (5 minutes).
 - B. Stop the engine, allow it to cool and drain the fuel tank; refer to Fuel Tank, page 37, or operate the engine until it stops.
 - C. Restart the engine and run it until it stops. Repeat, with the choke ON, until the engine will not restart.
 - D. Dispose of fuel properly or use within 90 days for other applications. Recycle in accordance with local codes.
11. Check and tighten all bolts, nuts, and screws. Repair or replace any part that is damaged or defective.
12. Paint all scratched or bare metal surfaces. Paint is available from your Authorized Service Dealer.
13. Store the machine in a clean, dry garage or storage area. Remove the keys from the ignition and “Key Choice” switches and keep them in a memorable place. Cover the machine to protect it and keep it clean.

Troubleshooting

PROBLEM	POSSIBLE CAUSES	CORRECTIVE ACTION
The starter does not crank.	<ol style="list-style-type: none"> 1. The PTO is ON. 2. The brake is not depressed or the parking brake is not on. 3. The operator is not seated. 4. The electrical connections are corroded or loose. 5. A fuse is blown or loose. 6. The relay or switch is defective. 7. The battery is discharged. 8. The safety interlock system is malfunctioning. 9. A faulty starter or starter solenoid. 10. Seized internal engine components. 	<ol style="list-style-type: none"> 1. Move the PTO to OFF. 2. Set the parking brake. 3. Sit on the seat. 4. Check the electrical connections for good contact. 5. Correct or replace fuse. 6. Contact Authorized Service Dealer. 7. Charge the battery or replace it. 8. Contact your Authorized Service Dealer. 9. Contact your Authorized Service Dealer. 10. Contact your Authorized Service Dealer.
The engine cranks, but will not start.	<ol style="list-style-type: none"> 1. Incorrect starting procedure. 2. The fuel tank is empty. 3. The fuel shut-off valve is closed. 4. Dirt, water or stale fuel is in the fuel system. 5. Clogged fuel line. 6. The spark plug lead is disconnected. 7. The kill relay is not energized. 8. A spark plug is faulty. 9. The ignition is faulty. 	<ol style="list-style-type: none"> 1. Refer to Starting and Stopping the Engine, page 18. 2. Fill with fresh fuel. 3. Open the fuel shut-off valve. 4. Drain and flush the fuel system; add fresh fuel. 5. Clean or replace. 6. Reconnect the spark plug. 7. Contact your Authorized Service Dealer. 8. Replace the spark plug. 9. Contact your Authorized Service Dealer.

PROBLEM	POSSIBLE CAUSES	CORRECTIVE ACTION
The engine starts, but does not keep running	<ol style="list-style-type: none"> 1. Misadjusted or faulty choke or throttle control cable. 2. The fuel tank vent is restricted. 3. Dirt or water in the fuel system. 4. The fuel filter is clogged. 5. The fuel pump is faulty. 6. The carburetor is faulty. 7. Loose wires or poor connections. 8. The cylinder head gasket is faulty. 9. A fuse is blown or loose. 	<ol style="list-style-type: none"> 1. Contact your Authorized Service Dealer. 2. Contact your Authorized Service Dealer. 3. Drain and flush the fuel system; add fresh fuel. 4. Replace the fuel filter. 5. Contact your Authorized Service Dealer. 6. Contact your Authorized Service Dealer. 7. Check and tighten wire connections. 8. Contact your Authorized Service Dealer. 9. Correct or replace fuse.
The engine runs, but knocks or misses.	<ol style="list-style-type: none"> 1. Dirt, water or stale fuel is in the fuel system. 2. A spark plug lead is loose. 3. A spark plug is faulty. 4. Loose wires or poor connections. 5. Engine overheating. 	<ol style="list-style-type: none"> 1. Drain and flush the fuel system; add fresh fuel. 2. Reconnect the spark plug lead. 3. Replace the spark plug. 4. Check and tighten wire connections. 5. See ENGINE OVERHEATS.
The engine will not idle.	<ol style="list-style-type: none"> 1. The fuel tank vent is restricted. 2. Dirt, water or stale fuel is in the fuel system. 3. A spark plug is faulty. 4. Carburetor idle passages are plugged. 5. The idle speed adjusting screw is incorrectly set. 6. The fuel pump is faulty. 7. Low compression. 8. The air cleaner element is dirty. 	<ol style="list-style-type: none"> 1. Contact your Authorized Service Dealer. 2. Drain and flush the fuel system; add fresh fuel. 3. Replace the spark plug. 4. Contact your Authorized Service Dealer. 5. Contact your Authorized Service Dealer. 6. Contact your Authorized Service Dealer. 7. Contact your Authorized Service Dealer. 8. Clean or replace.

PROBLEM	POSSIBLE CAUSES	CORRECTIVE ACTION
The engine overheats.	<ol style="list-style-type: none"> 1. The crankcase oil level is incorrect. 2. The fuel mixture is lean. 3. Excessive loading. 4. (3) air intake screens are dirty. 5. The cooling fins and air passages under the engine blower housing and/or the rotating air intake screen are plugged. 	<ol style="list-style-type: none"> 1. Fill or drain to the full mark. 2. Contact your Authorized Service Dealer. 3. Reduce load; use lower ground speed. 4. Clean with every use. 5. Clean with every use.
The engine loses power.	<ol style="list-style-type: none"> 1. The crankcase oil level is incorrect. 2. The air cleaner element is dirty. 3. Dirt, water or stale fuel is in the fuel system. 4. The engine is overheated. 5. A spark plug is faulty. 6. Low compression. 7. The vent hole in the fuel tank vent fitting is plugged. 8. The engine load is excessive. 	<ol style="list-style-type: none"> 1. Fill or drain to the full mark. 2. Clean or replace. 3. Drain and flush the fuel system; add fresh fuel. 4. See ENGINE OVERHEATS. 5. Replace the spark plug. 6. Contact your Authorized Service Dealer. 7. Contact your Authorized Service Dealer. 8. Reduce ground speed.
The tractor will not operate in either direction because the engine bogs down or stalls.	<ol style="list-style-type: none"> 1. The brake is sticking. 	<ol style="list-style-type: none"> 1. Contact your Authorized Service Dealer.
The tractor goes forward only at partial speed and is slow or does not operate in reverse.	<ol style="list-style-type: none"> 1. The cruise control was engaged when the traction pedal was in neutral. 2. The engine is running at partial speed. 3. The linkage is out of adjustment. 4. There is internal hydro wear. 	<ol style="list-style-type: none"> 1. Turn the cruise control off. 2. Move the throttle to "FAST." 3. Contact your Authorized Service Dealer. 4. Contact your Authorized Service Dealer.

PROBLEM	POSSIBLE CAUSES	CORRECTIVE ACTION
<p>The tractor will not operate in either direction.</p>	<ol style="list-style-type: none"> 1. The High–Low range lever is in “N.” 2. The transmission oil is low. 3. The transmission is faulty. 4. The control linkage needs adjustment or replacement. 5. The parking brake was not released or the parking brake is not releasing. 6. The drive shaft or wheel hub key has been damaged. 	<ol style="list-style-type: none"> 1. Move the High–Low range lever to “L” or “H.” 2. Fill to the full “F” mark on the transmission oil dipstick when the transmission is cold. 3. Contact your Authorized Service Dealer. 4. Contact your Authorized Service Dealer. 5. Release the parking brake or check the linkage. 6. Contact your Authorized Service Dealer.
<p>The tractor operates erratically.</p>	<ol style="list-style-type: none"> 1. The transmission oil level is low. 2. The transmission control linkage needs adjustment or replacement. 3. The transmission is faulty. 	<ol style="list-style-type: none"> 1. Fill to the full “F” mark on the transmission oil dipstick when the transmission is cold. 2. Contact your Authorized Service Dealer. 3. Contact your Authorized Service Dealer.
<p>The tractor operates in both directions, but with a loss of power. This condition becomes worse as the transmission becomes hot.</p>	<ol style="list-style-type: none"> 1. The transmission oil level is low. 2. The transmission shows signs of overheating or water contamination. 3. The cooling fan and/or transmission cooling fins are faulty or dirty. 4. The engine is not operating at full throttle. 	<ol style="list-style-type: none"> 1. Fill to the full “F” mark on the transmission oil dipstick when the transmission is cold. 2. Replace the transmission oil and filter. 3. Clean the transmission and/or replace the fan (contact your Authorized Service Dealer). 4. Increase the engine speed to full throttle.

PROBLEM	POSSIBLE CAUSES	CORRECTIVE ACTION
Abnormal vibration or noise.	<ol style="list-style-type: none"> 1. The engine mounting bolts are loose. 2. The idler pulley or cutter deck blade is loose. 3. The transaxle cooling fan is loose. 4. There is a problem with the electric clutch 	<ol style="list-style-type: none"> 1. Tighten the engine mounting bolts. 2. Tighten the appropriate pulley. 3. Contact your Authorized Service Dealer. 4. Contact your Authorized Service Dealer.
PTO (cutter deck) belt comes off of pulleys, slips, or fails.	<ol style="list-style-type: none"> 1. Belt tension is incorrect. 2. Mower level is incorrect 3. Blade slope in transport is incorrect. 4. Cutter deck belt guide is loose or incorrectly adjusted. 5. Belt is worn or damaged. 6. Pulley is damaged. 7. Engine is not at full throttle. 8. PTO is being engaged when cutter deck is in tall uncut grass or weeds. 9. Cutter deck is overloaded because mulching or bagging requires more power. 10. Cutter deck is overloaded because too much grass is being cut at a time. 11. Cutter deck is overloaded because deck is clogged with grass clippings. 12. Cutter deck is overloaded because tractor is mowing too fast for conditions. 	<ol style="list-style-type: none"> 1. See cutter deck or attachment manual. 2. See cutter deck manual. 3. See cutter deck manual. 4. Adjust and tighten belt guide. 5. See cutter deck or attachment manual. 6. Contact authorized dealer. 7. Always operate engine powered attachments at full throttle. 8. Engage PTO only in shorter or previously cut grass. 9. Reduce ground speed when mulching or bagging. 10. Cut tall grass and weeds with mower in its highest position, making a second pass cutting at height desired. 11. Clean cutter deck. 12. Reduce ground speed.