



**Count on it.**

**Operator's Manual**

# 122cm or 132cm TITAN<sup>®</sup> HD 1500 Series Riding Mower

Model No. 74465TE—Serial No. 40000000 and Up

Model No. 74466TE—Serial No. 40000000 and Up

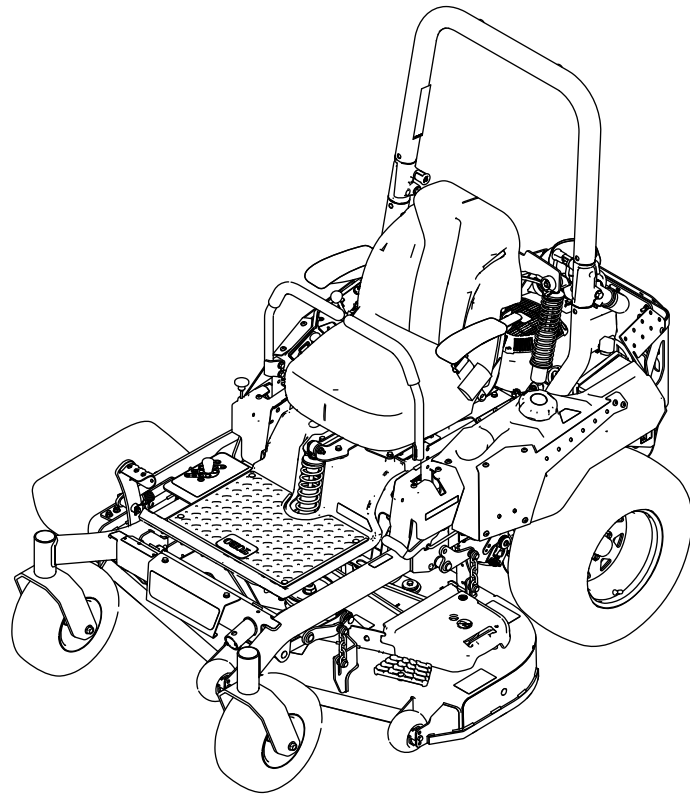

This product complies with all relevant European directives; for details, please see the separate product specific Declaration of Conformity (DOC) sheet.

Go to [www.Toro.com](http://www.Toro.com) to view specifications on your model.

**Gross or Net Torque:** The gross or net torque of this engine was laboratory rated by the engine manufacturer in accordance with the Society of Automotive Engineers (SAE) J1940 or J2723. As configured to meet safety, emission, and operating requirements, the actual engine torque on this class of mower will be significantly lower.

**Important:** If you are using a machine with a Toro engine above 1500 m (5,000 ft) for a continuous period, ensure that the High Altitude Kit has been installed so that the engine meets CARB/EPA emission regulations. The High Altitude Kit increases engine performance while preventing spark-plug fouling, hard starting, and increased emissions. Once you have installed the kit, attach the high-altitude label next to the serial decal on the machine. Contact any Authorized Toro Service Dealer to obtain the proper High Altitude Kit and high-altitude label for your machine. To locate a dealer convenient to you, access our website at [www.Toro.com](http://www.Toro.com) or contact our Toro Customer Care Department at the number(s) listed in your Emission Control Warranty Statement.

Remove the kit from the engine and restore the engine to its original factory configuration when running the engine under 1500 m (5,000 ft). Do not operate an engine that has been converted for high-altitude use at lower altitudes; otherwise, you could overheat and damage the engine.

If you are unsure whether or not your machine has been converted for high-altitude use, look for the following label (Figure 3).

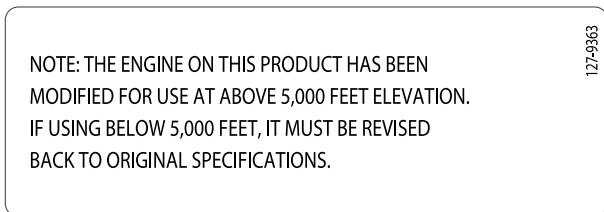

Figure 3

decal127-9363

# Introduction

This rotary-blade, riding lawn mower is intended to be used by professional, hired operators. It is designed primarily for cutting grass on well-maintained lawns on residential or commercial properties. It is not designed for cutting brush or for agricultural uses.

Read this information carefully to learn how to operate and maintain your product properly and to avoid injury and product damage. You are responsible for operating the product properly and safely.

You may contact Toro directly at [www.Toro.com](http://www.Toro.com) for product safety and operation training materials, accessory information, help finding a dealer, or to register your product.

Whenever you need service, genuine Toro parts, or additional information, contact an Authorized Service Dealer or Toro Customer Service and have the model and serial numbers of your product ready. Figure 1 identifies the location of the model and serial numbers on the product. Write the numbers in the space provided.

**Important:** With your mobile device, you can scan the QR code (if equipped) on the serial number decal to access warranty, parts, and other product information.

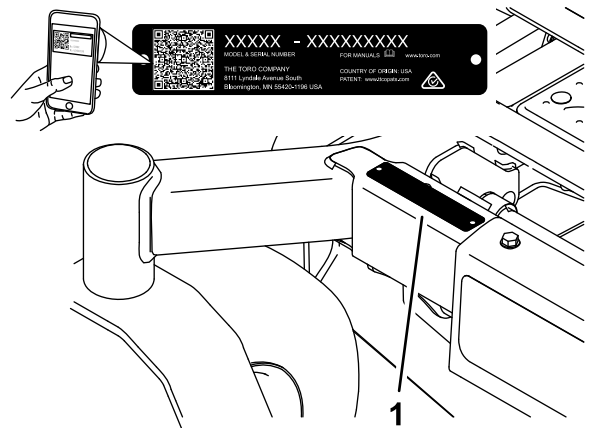

Figure 1

g233855

Model No. _____
Serial No. _____

This manual identifies potential hazards and has safety messages identified by the safety-alert symbol (Figure 2), which signals a hazard that may cause serious injury or death if you do not follow the recommended precautions.



**Figure 2**  
Safety-alert symbol

g000502

# Contents

Safety .....	4
General Safety .....	4
Slope Indicator .....	5
Safety and Instructional Decals .....	6
Product Overview .....	12
Controls .....	12
Specifications .....	14
Before Operation .....	14
Before Operation Safety .....	14
Adding Fuel .....	15
Performing Daily Maintenance.....	16
Breaking in a New Machine .....	16
Using the Rollover-Protection System (ROPS).....	16
Using the Safety-Interlock System.....	17
Positioning the Seat.....	18
Adjusting the MyRide™ Suspension System.....	19
Using Attachments and Accessories.....	20
During Operation .....	20
During Operation Safety .....	20
Entering the Operator's Position .....	22
Operating the Parking Brake.....	22
Operating the Mower Blade-Control Switch (PTO).....	22
Operating the Throttle.....	23
Operating the Choke .....	23
Starting the Engine .....	24
Shutting Off the Engine.....	24
Using the Motion-Control Levers.....	25
Driving the Machine .....	25
Adjusting the Height of Cut .....	26
Adjusting the Anti-Scalp Rollers.....	27
Using the Side Discharge .....	28
Operating Tips .....	28
After Operation .....	29
After Operation Safety .....	29
Using the Fuel-Shutoff Valve.....	29
Using the Drive-Wheel Release Valves.....	29
Transporting the Machine .....	30
Maintenance .....	32
Recommended Maintenance Schedule(s) .....	32
Pre-Maintenance Procedures .....	33
Maintenance Safety.....	33
Releasing the Mower-Deck Curtain .....	33
Removing the Sheet-Metal Guard.....	34
Lubrication .....	34
Greasing the Machine.....	34
Engine Maintenance .....	35
Engine Safety .....	35
Servicing the Air Cleaner .....	35
Servicing the Engine Oil.....	37
Servicing the Spark Plug.....	39
Cleaning the Cooling System.....	40
Checking the Spark Arrester .....	40

---

This manual uses 2 words to highlight information. **Important** calls attention to special mechanical information and **Note** emphasizes general information worthy of special attention.

Replacing the Emissions-Air Intake Filter.....	40
Fuel System Maintenance .....	41
Replacing the Fuel Filter .....	41
Servicing the Fuel Tank.....	41
Electrical System Maintenance .....	42
Electrical System Safety .....	42
Servicing the Battery.....	42
Servicing the Fuses .....	44
Drive System Maintenance .....	44
Checking the Seat Belt .....	44
Checking the Roll-Bar Knobs .....	44
Adjusting the Tracking .....	45
Checking the Tire Pressure.....	46
Checking the Wheel Lug Nuts.....	46
Cooling System Maintenance .....	46
Cleaning the Engine Screen .....	46
Brake Maintenance .....	47
Adjusting the Parking Brake.....	47
Belt Maintenance .....	48
Inspecting the Belts .....	48
Replacing the Mower Belt .....	48
Replacing the Hydraulic-Pump-Drive Belt.....	49
Controls System Maintenance .....	50
Adjusting the Control-Handle Position .....	50
Adjusting the Motion-Control Linkage .....	51
Hydraulic System Maintenance .....	52
Hydraulic System Safety.....	52
Servicing the Hydraulic System .....	52
Mower Deck Maintenance.....	55
Servicing the Cutting Blades.....	55
Leveling the Mower Deck.....	57
Removing the Mower Deck.....	59
Replacing the Grass Deflector .....	59
Cleaning .....	60
Cleaning under the Mower Deck .....	60
Cleaning the Suspension System .....	60
Disposing of Waste.....	60
Storage .....	61
Storage Safety.....	61
Cleaning and Storage.....	61
Troubleshooting .....	62
Schematics .....	64

# Safety

This machine has been designed in accordance with EN ISO 5395:2013.

## General Safety

This product is capable of amputating hands and feet and of throwing objects. Always follow all safety instructions to avoid serious personal injury.

Using this product for purposes other than its intended use could prove dangerous to you and bystanders.

- Always keep the roll bar in the fully raised and locked position and use the seat belt.
- Use your full attention while operating the machine. Do not engage in any activity that causes distractions; otherwise, injury or property damage may occur.
- Do not operate the machine near drop-offs, ditches, embankments, water, or other hazards, or on slopes greater than 15 degrees.
- Read and understand the contents of this *Operator's Manual* before starting the engine.
- Do not put your hands or feet near moving components of the machine.
- Do not operate the machine without all guards and other safety protective devices in place and working on the machine.
- Keep children and bystanders out of the operating area. Never allow children to operate the machine.
- Stop the machine, shut off the engine, and remove the key before servicing, fueling, or unclogging the machine.

Improperly using or maintaining this machine can result in injury. To reduce the potential for injury, comply with these safety instructions and always pay attention to the safety-alert symbol, which means Caution, Warning, or Danger—personal safety instruction. Failure to comply with these instructions may result in personal injury or death.

You can find additional safety information where needed throughout this manual.

# Slope Indicator

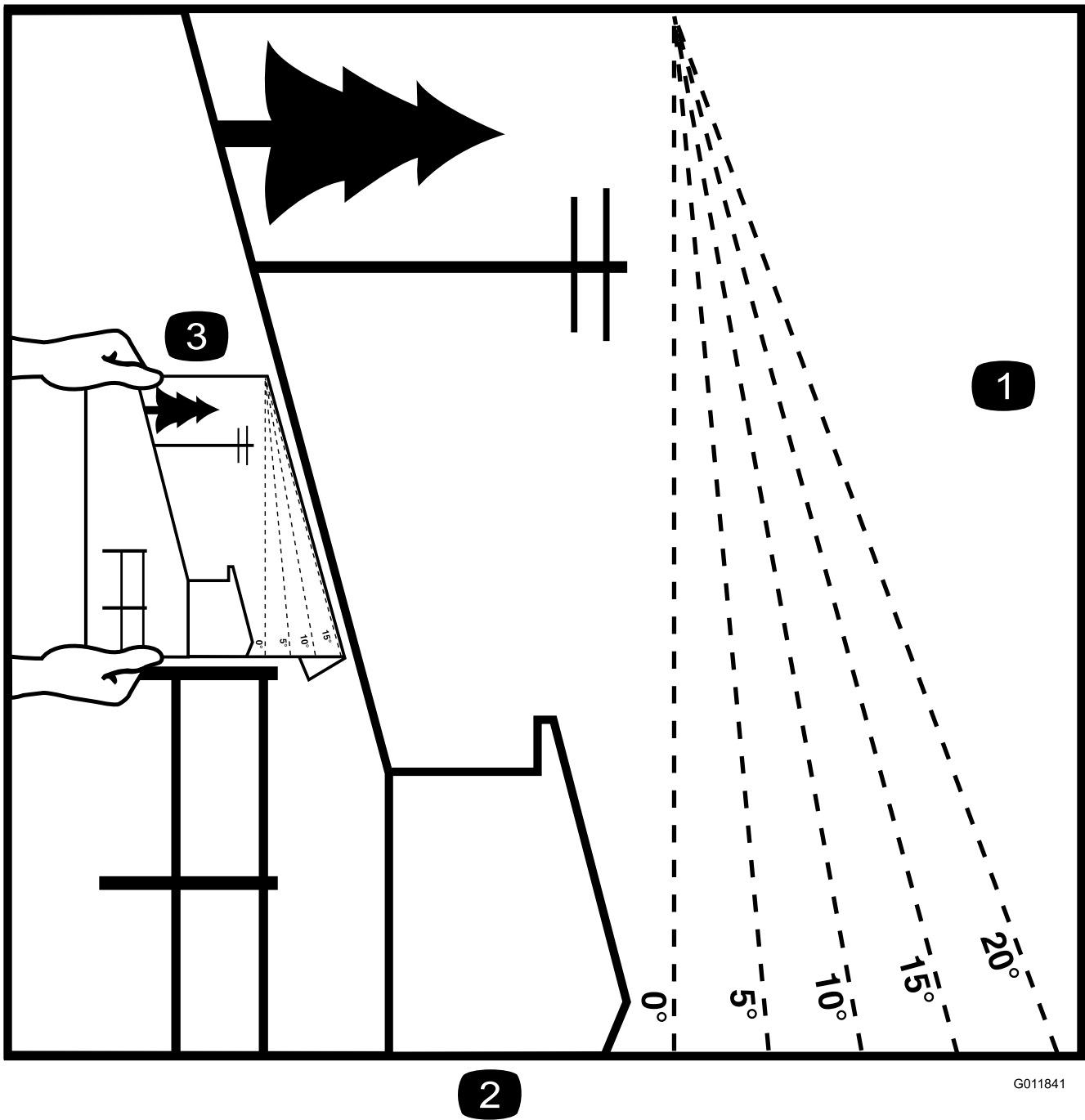

G011841

g011841

**Figure 4**

You may copy this page for personal use.

1. The maximum slope you can operate the machine on is **15 degrees**. Use the slope chart to determine the degree of slope of hills before operating. **Do not operate this machine on a slope greater than 15 degrees**. Fold along the appropriate line to match the recommended slope.
2. Align this edge with a vertical surface, a tree, building, fence pole, etc.
3. Example of how to compare slope with folded edge

# Safety and Instructional Decals



Safety decals and instructions are easily visible to the operator and are located near any area of potential danger. Replace any decal that is damaged or missing.

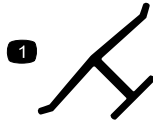

decal93-7818

## Manufacturer's Mark

1. Indicates the blade is identified as a part from the original machine manufacturer.

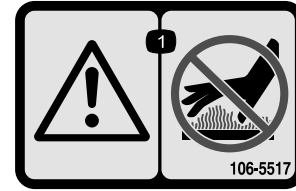

decal106-5517

## 106-5517

1. Warning—do not touch the hot surface.

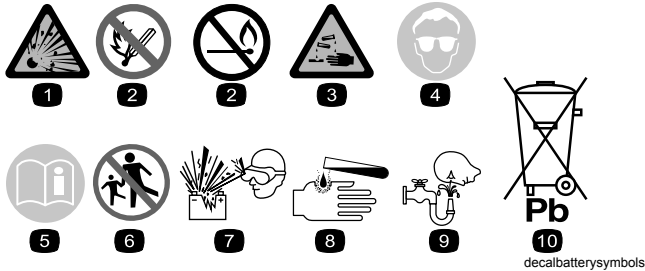

decalbatterysymbols

## Battery Symbols

Some or all of these symbols are on your battery.

- |  |   |
|--|---|
| 1. Explosion hazard                    | 6. Keep bystanders a safe distance away from the battery.                       |
| 2. No fire, open flame, or smoking     | 7. Wear eye protection; explosive gases can cause blindness and other injuries. |
| 3. Caustic liquid/chemical burn hazard | 8. Battery acid can cause blindness or severe burns.                            |
| 4. Wear eye protection.                | 9. Flush eyes immediately with water and get medical help fast.                 |
| 5. Read the <i>Operator's Manual</i> . | 10. Contains lead; do not discard   |

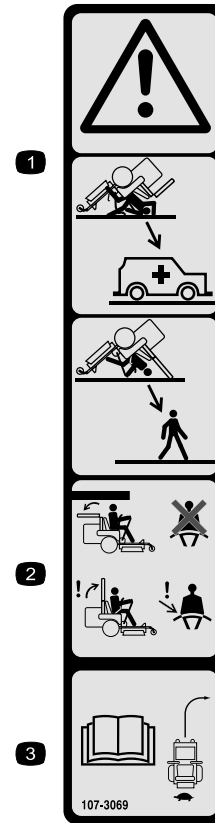

decal107-3069

## 107-3069

1. Warning—there is no rollover protection when the roll bar is down.
2. To avoid injury or death from a rollover accident, keep the roll bar in the fully raised and locked position and wear the seat belt. Lower the roll bar only when absolutely necessary; do not wear the seat belt when the roll bar is down.
3. Read the *Operator's Manual*; drive slowly and carefully.

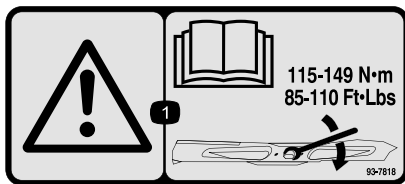

decal93-7818

## 93-7818

1. Warning—read the *Operator's Manual* for instructions on torquing the blade bolt/nut to 115-149 N·m (85-110 ft-lb).

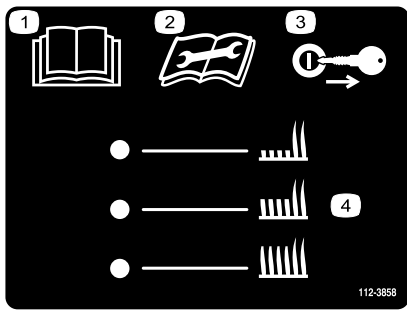

**112-3858**

decal112-3858

1. Read the *Operator's Manual*.
2. Read the instructions before servicing or performing maintenance.
3. Remove the key before adjusting the height of cut.
4. Height-of-cut settings.

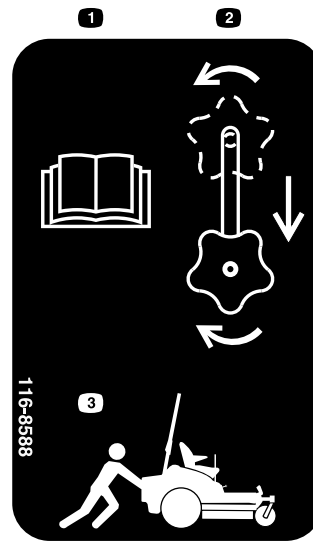

**116-8588**

decal116-8588

1. Read the *Operator's Manual*.
2. Rotate the drive release knob to loosen, slide the knob, and tighten.
3. Push the machine.

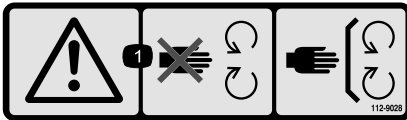

**112-9028**

decal112-9028

1. Warning—stay away from moving parts; keep all guards in place.

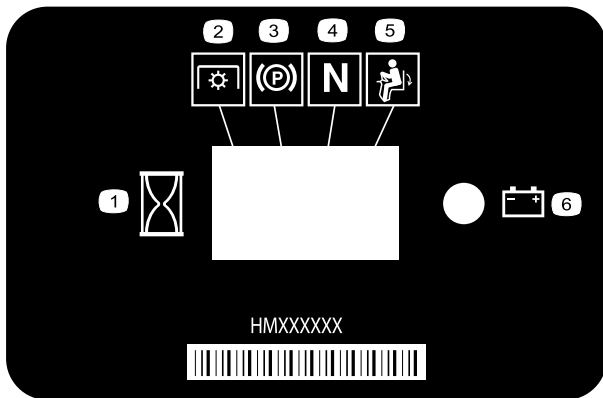

**116-5610**

decal116-5610

1. Hour meter
2. Power take-off (PTO)
3. Parking brake
4. Neutral
5. Operator-presence switch
6. Battery

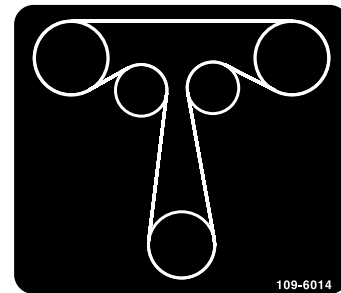

**109-6014**

decal109-6014

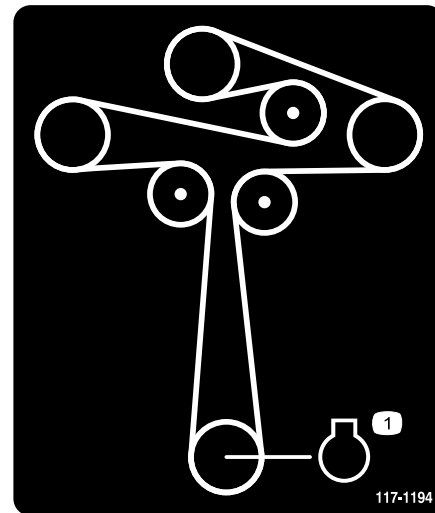

**117-1194**

decal117-1194

1. Engine



117-3848

decal117-3848

1. Thrown object hazard—keep bystanders a safe distance away from the machine.
2. Thrown object hazard, mower—do not operate the machine without deflector, discharge cover, or grass collection system in place.
3. Cutting/dismemberment of hand or foot—stay away from moving parts; keep all guards and shields in place.

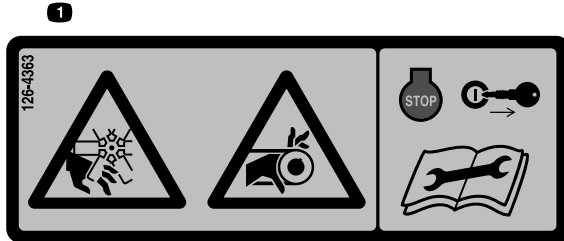

126-4363

decal126-4363

1. Cutting/dismemberment hazard, fan and entanglement hazard, belt. Shut off the engine and remove the key before adjusting, servicing or cleaning the machine.

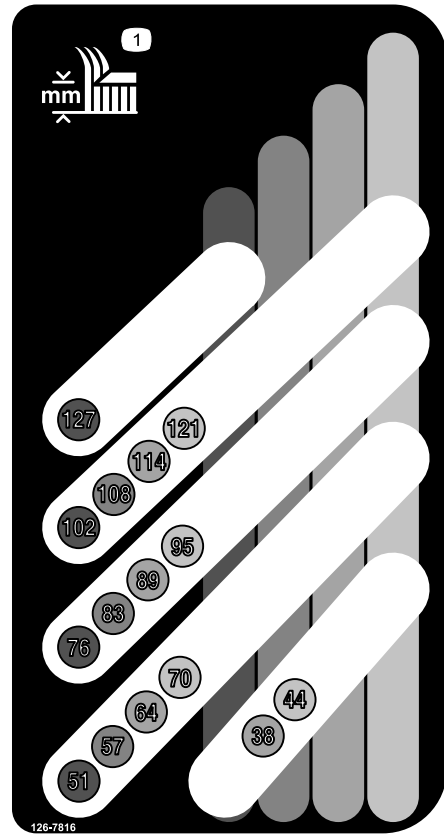

126-7816

decal126-7816

1. Height of cut

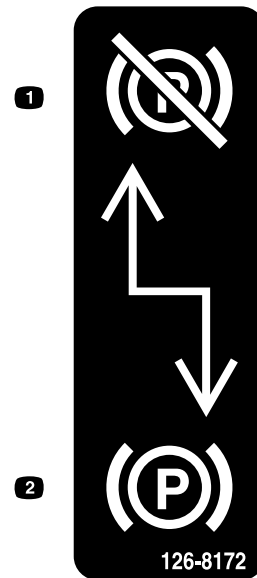

126-8172

decal126-8172

1. Parking brake disengaged
2. Parking brake engaged

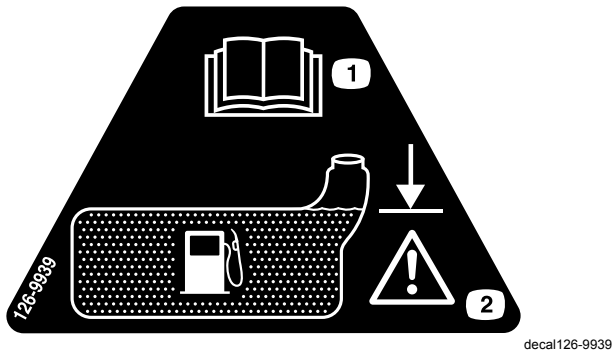

**126-9939**

1. Read the *Operator's Manual*.
2. Fill to the bottom of the filler neck; warning—do not overfill the tank.

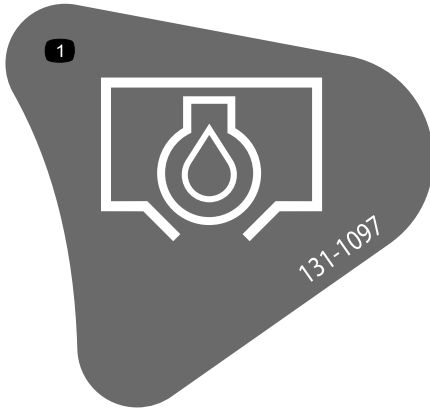

**131-1097**

Toro Engines Only

1. Oil drain

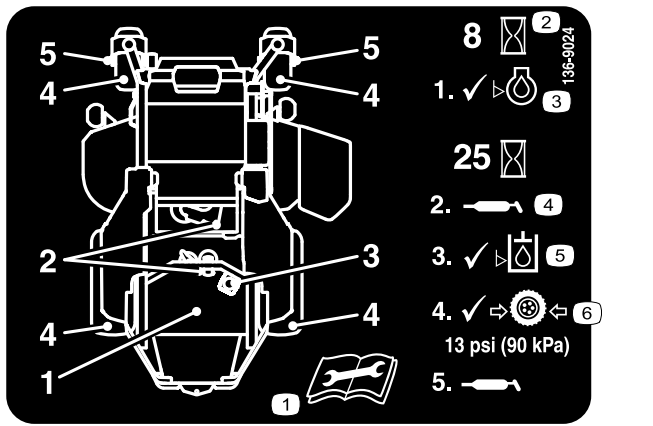

**136-9024**

1. Read the *Operator's Manual* before performing maintenance.
2. Operating hours
3. Engine-oil level
4. Grease point
5. Hydraulic-fluid level
6. Tire pressure

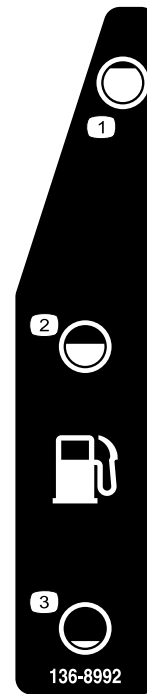

**136-8992**

1. Fuel—full
2. Fuel—50%
3. Fuel—empty

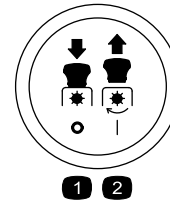

**PTO Switch Symbols**

1. PTO—disengage
2. PTO—engage

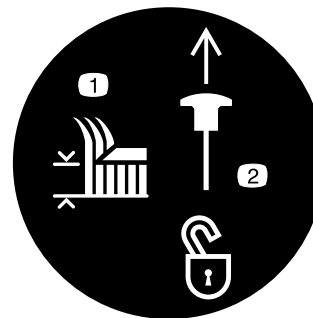

**Transport Lock**

1. Height of cut
2. Pull up to unlock the transport lock.

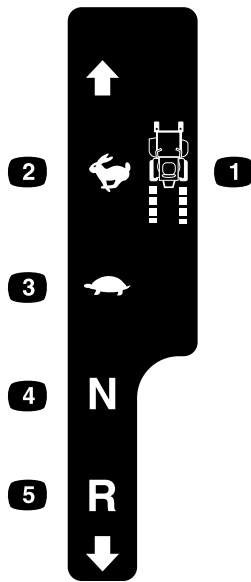

**Left Motion Control**

decalmotioncntrlrh-126-6194

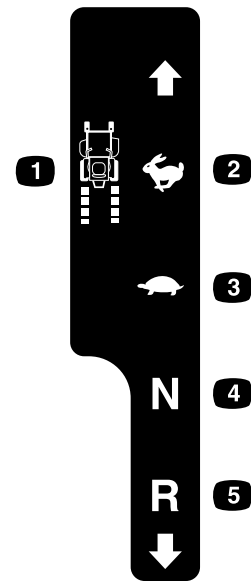

**Right Motion Control**

decalmotioncntrlrh-126-6183

- 1. Machine speed
- 2. Fast
- 3. Slow

- 4. Neutral
- 5. Reverse

- 1. Machine speed
- 2. Fast
- 3. Slow

- 4. Neutral
- 5. Reverse

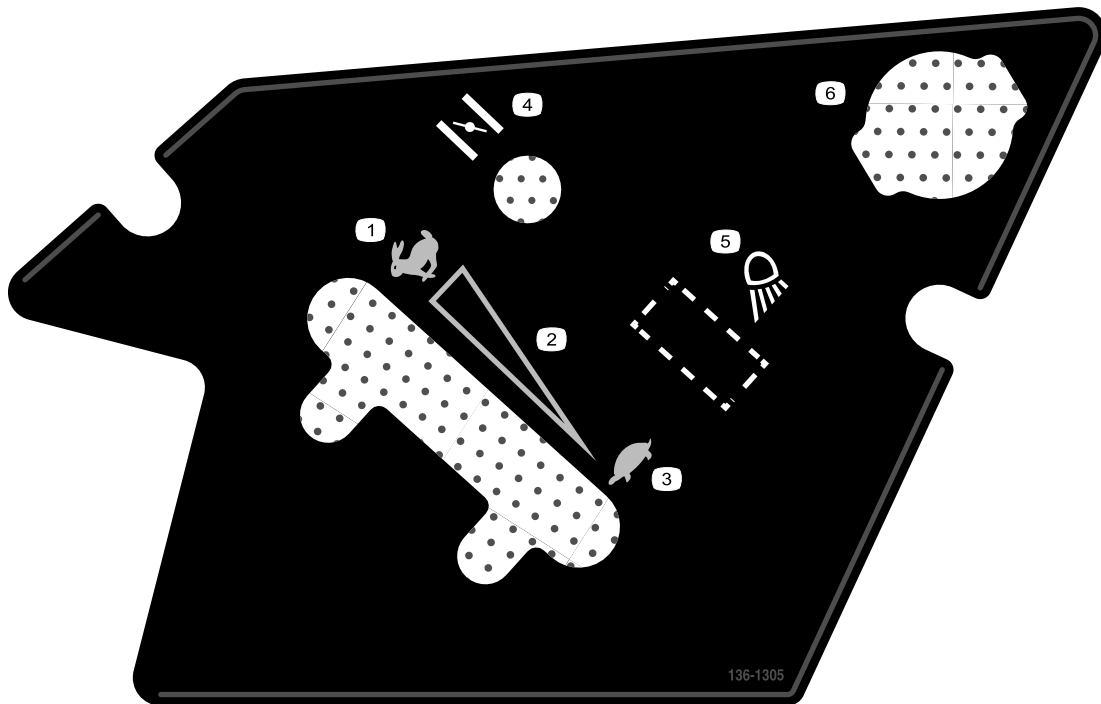

**136-1305**

decal136-1305

- 1. Fast
- 2. Continuous-variable setting
- 3. Slow

- 4. Choke
- 5. Work light (optional)
- 6. Power point

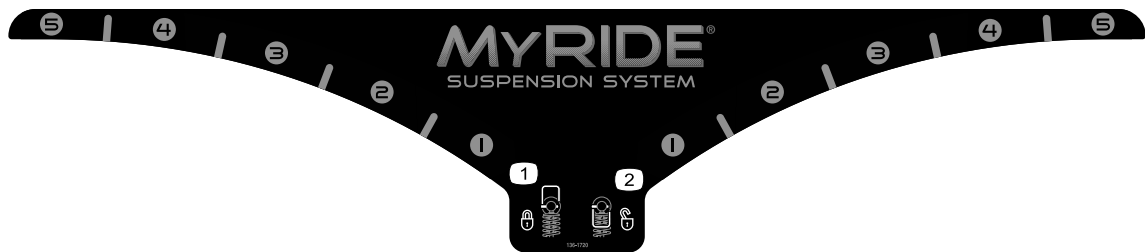

136-1720

decal136-1720

1. Cam lock

2. Cam unlock

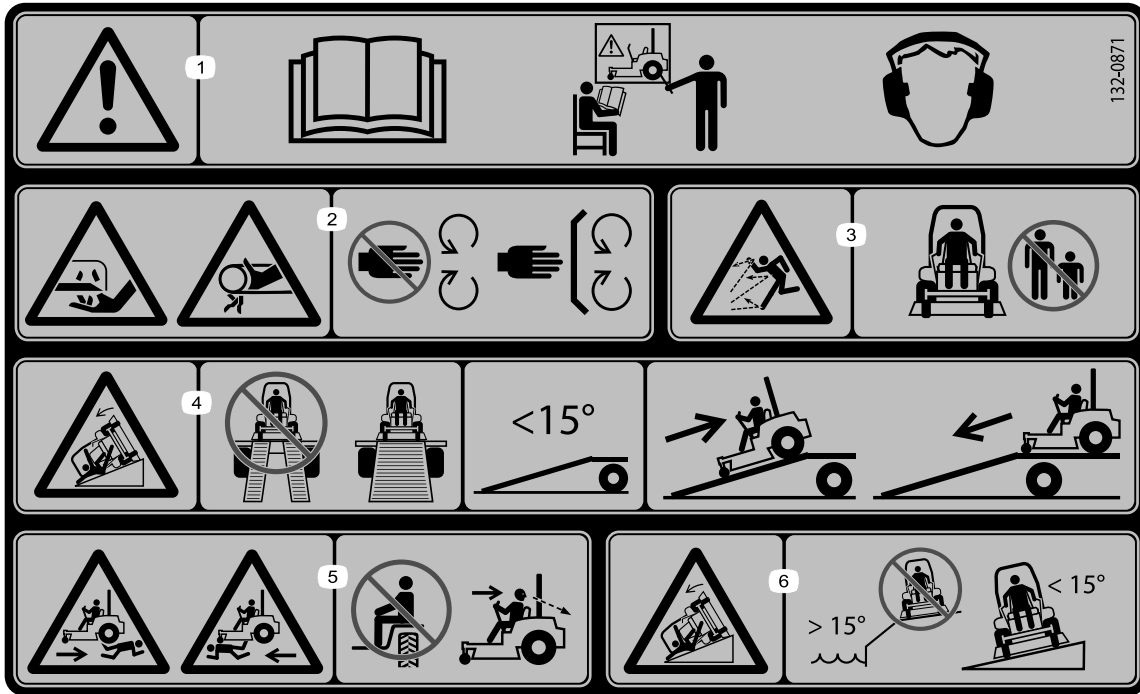

132-0871

decal132-0871

**Note:** This machine complies with the industry standard stability test in the static lateral and longitudinal tests with the maximum recommended slope indicated on the decal. Review the instructions for operating the machine on slopes in the *Operator's Manual* as well as the conditions in which you would operate the machine to determine whether you can operate the machine in those conditions on that day and at that site. Changes in the terrain can result in a change in slope operation for the machine. If possible, keep the cutting units lowered to the ground while operating the machine on slopes. Raising the cutting units while operating on slopes can cause the machine to become unstable.

1. Warning—read the *Operator's Manual*; do not operate this machine unless you are trained; wear hearing protection.
2. Cutting, dismembering, and entanglement hazard—keep hands away from moving parts; keep all guards and shields in place.
3. Thrown object hazard—keep bystanders away.
4. Ramp hazard—when loading onto a trailer, do not use dual ramps; only use a singular ramp wide enough for the machine and that has an incline less than 15°; back up the ramp (in reverse) and drive forward off the ramp.
5. Bodily harm hazard—do not carry passengers; look behind you when mowing in reverse.
6. Tipping hazard on slopes—do not use on slopes near open water; do not use on slopes greater than 15°.

# Product Overview

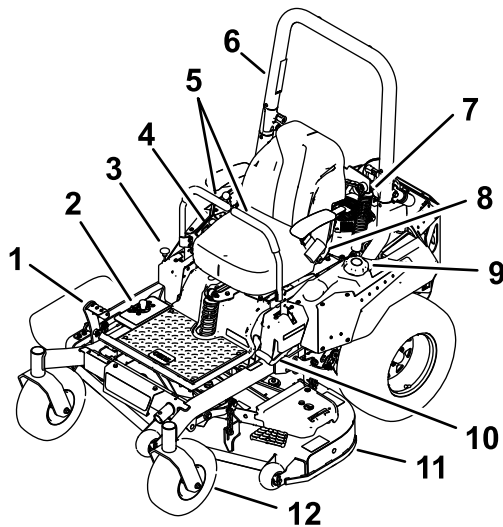

Figure 5

g227688

- |                                  |                         |
|----------------------------------|-------------------------|
| 1. Height-of-cut deck-lift pedal | 7. Shock assembly       |
| 2. Height-of-cut positions       | 8. Seat belt            |
| 3. Transport lock                | 9. Fuel cap             |
| 4. Controls                      | 10. Parking-brake lever |
| 5. Motion-control levers         | 11. Mower deck          |
| 6. Roll bar                      | 12. Caster wheel        |

## Controls

Become familiar with all the controls before you start the engine and operate the machine (Figure 5 and Figure 6).

## Control Panel

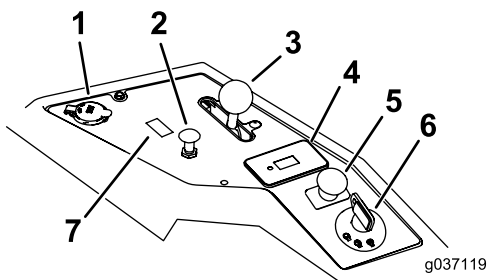

Figure 6

g037119

g037119

- |                     |   |
|---------------------|---|
| 1. Power port       | 5. Blade-control switch (power takeoff)   |
| 2. Choke control    | 6. Key switch                             |
| 3. Throttle control | 7. Switch position for optional light kit |
| 4. Hour meter       |   |

## Key Switch

The key switch, used to start and shut off the engine, has 3 positions: OFF, RUN, and START. Refer to [Starting the Engine \(page 24\)](#).

## Choke Control

Use the choke control to start a cold engine. Pull the choke control up to engage it. Push down on the choke control to disengage it.

## Throttle Control

The throttle controls the engine speed, and it has a continuous-variable setting from the SLOW to FAST position (Figure 6).

## Blade-Control Switch (Power Takeoff)

The blade-control switch, represented by a power-takeoff (PTO) symbol, engages and disengages power to the mower blades (Figure 6).

## Hour Meter

The hour meter records the number of hours the engine has operated. It operates when the engine is running. Use these times for scheduling regular maintenance (Figure 7).

## Safety-Interlock Indicators

There are symbols on the hour meter that indicate with a black triangle that the interlock component is positioned correctly (Figure 7).

## Battery-Indicator Light

If you turn the ignition key to the ON position for a few seconds, the battery voltage displays in the area where the hours are normally displayed.

The battery light turns on when the ignition is turned on and when the charge is below the correct operating level (Figure 7).

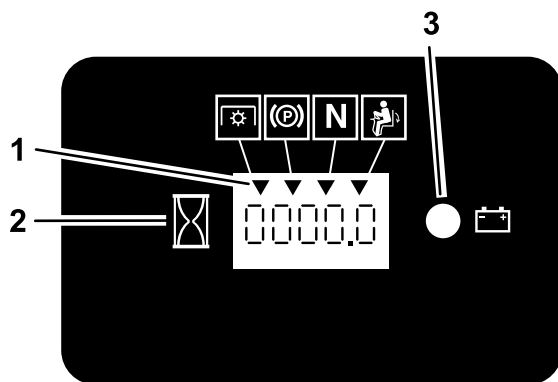

g187133

Figure 7

1. Safety-interlock symbols
2. Hour meter
3. Battery light

---

## Motion-Control Levers

Use the motion-control levers to drive the machine forward, reverse, and turn either direction (Figure 5).

## Neutral-Lock Position

Use the NEUTRAL-LOCK position with the safety-interlock system to engage and to determine the NEUTRAL position.

## Fuel-Shutoff Valve

Close the fuel-shutoff valve when transporting or storing the machine; refer to [Using the Fuel-Shutoff Valve \(page 29\)](#).

## Attachments/Accessories

A selection of Toro approved attachments and accessories is available for use with the machine to enhance and expand its capabilities. Contact your Authorized Service Dealer or authorized Toro distributor or go to [www.Toro.com](http://www.Toro.com) for a list of all approved attachments and accessories.

To ensure optimum performance and continued safety certification of the machine, use only genuine Toro replacement parts and accessories. Replacement parts and accessories made by other manufacturers could be dangerous, and such use could void the product warranty.

# Specifications

**Note:** Specifications and design are subject to change without notice.

## Width:

	122 cm mower deck	132 cm mower deck
Without mower deck	121 cm (47-1/2 inches)	124 cm (49 inches)
Deflector up	133 cm (53 inches)	144 cm (56-3/4 inches)
Deflector down	160 cm (63-1/4 inches)	171 cm (67-1/4 inches)

## Length:

	122 cm mower deck	132 cm mower deck
Length	208 cm (82 inches)	208 cm (82 inches)

## Height:

Roll Bar Up	Roll Bar Down
179 cm (70-1/2 inches)	125 cm (49 inches)

## Weight:

Machines	Weight
<b>Machines with 122 cm mower deck</b>	421 kg
	928 lb
<b>Machines with 132 cm mower deck</b>	429 kg
	946 lb

# Operation

**Note:** Determine the left and right sides of the machine from the normal operating position.

## Before Operation

### Before Operation Safety

#### General Safety

- Never allow children or untrained people to operate or service the machine. Local regulations may restrict the age of the operator. The owner is responsible for training all operators and mechanics.
- Become familiar with the safe operation of the equipment, operator controls, and safety signs.
- Know how to stop the machine and shut off the engine quickly.
- Check that operator-presence controls, safety switches, and shields are attached and functioning properly. Do not operate the machine unless they are functioning properly.

- Before mowing, always inspect the machine to ensure that the blades, blade bolts, and cutting assemblies are in good working condition. Replace worn or damaged blades and bolts in sets to preserve balance.
- Inspect the area where you will use the machine and remove all objects that the machine could throw.
- Evaluate the terrain to determine the appropriate equipment and any attachments or accessories required to operate the machine properly and safely.

#### Fuel Safety

- To avoid personal injury or property damage, use extreme care in handling fuel. Fuel vapors are flammable and explosive.
- Extinguish all cigarettes, cigars, pipes, and other sources of ignition.
- Use only an approved fuel container.
- Do not remove the fuel cap or add fuel to the fuel tank while the engine is running or while hot.
- Do not refuel the machine indoors.

- Do not store the machine or fuel container where there is an open flame, spark, or pilot light, such as on a water heater or on other appliances.
- Do not fill containers inside a vehicle or on a truck or trailer bed with a plastic liner. Always place containers on the ground, away from your vehicle before filling.
- Remove the equipment from the truck or trailer and refuel it while it is on the ground. If this is not possible, then refuel from a portable container rather than a fuel-dispenser nozzle.
- Do not operate the machine without the entire exhaust system in place and in proper working condition.
- Keep the fuel-dispenser nozzle in contact with the rim of the fuel tank or container opening at all times until fueling is complete. Do not use a nozzle lock-open device.
- If you spill fuel on your clothing, change your clothing immediately. Wipe up any fuel that spills.
- Never overfill the fuel tank. Replace the fuel cap and tighten it securely.
- Store fuel in an approved container and keep it out of the reach of children. Never buy more than a 30-day supply of fuel.
- Do not fill the fuel tank completely full. Add fuel to the fuel tank until the level is 6 to 13 mm (1/4 to 1/2 inch) below the bottom of the filler neck. This empty space in the tank allows fuel to expand.
  - Avoid prolonged breathing of vapors.
  - Keep your face away from the nozzle and fuel tank opening.
  - Avoid contact with skin; wash off spills with soap and water.

## Adding Fuel

### Recommended Fuel

- For best results, use only clean, fresh (less than 30 days old), unleaded gasoline with an octane rating of 87 or higher ((R+M)/2 rating method).
- **Ethanol:** Gasoline with up to 10% ethanol (gasohol) or 15% MTBE (methyl tertiary butyl ether) by volume is acceptable. Ethanol and MTBE are not the same. Gasoline with 15% ethanol (E15) by volume is not approved for use. **Never use gasoline that contains more than 10% ethanol by volume**, such as E15 (contains 15% ethanol), E20 (contains 20% ethanol), or E85 (contains up to 85% ethanol). Using unapproved gasoline may cause performance problems and/or engine damage which may not be covered under warranty.
- **Do not** use gasoline containing methanol.
- **Do not** store fuel either in the fuel tank or fuel containers over the winter unless you use a fuel stabilizer.
- **Do not** add oil to gasoline.

### Using Stabilizer/Conditioner

Use fuel stabilizer/conditioner in the machine at all times to keep the fuel fresh longer when used as directed by the fuel-stabilizer manufacturer.

**Important:** Do not use fuel additives containing methanol or ethanol.

Add the amount of fuel stabilizer/conditioner to fresh fuel as directed by the fuel-stabilizer manufacturer.

### Filling the Fuel Tank

1. Park the machine on a level surface.
2. Engage the parking brake.
3. Shut off the engine and remove the key.
4. Clean around the fuel-tank cap.
5. Fill the fuel tank until the fuel gauge reads at the full mark ([Figure 8](#)).

**Note:** Do not fill the fuel tank completely full. The empty space in the tank allows the fuel to expand.

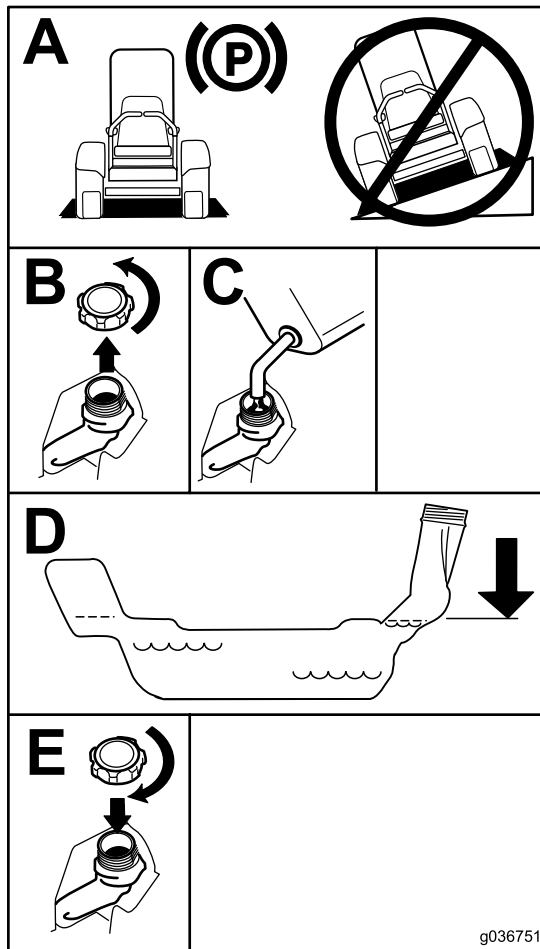

Figure 8

g036751

## Using the Rollover-Protection System (ROPS)

### ⚠ WARNING

To avoid injury or death from rollover, keep the roll bar in the fully raised, locked position and use the seat belt.

Ensure that the seat is secured to the machine.

### ⚠ WARNING

There is no rollover protection when the roll bar is in the down position.

- Lower the roll bar only when absolutely necessary.
- Do not wear the seat belt when the roll bar is in the down position.
- Drive slowly and carefully.
- Raise the roll bar as soon as clearance permits.
- Check carefully for overhead clearances (i.e., branches, doorways, electrical wires) before driving under any objects and do not contact them.

## Performing Daily Maintenance

Before starting the machine each day, perform the Each Use/Daily procedures listed in [Maintenance \(page 32\)](#).

## Breaking in a New Machine

New engines take time to develop full power. Mower decks and drive systems have higher friction when new, placing additional load on the engine. Allow 40 to 50 hours of break-in time for new machines to develop full power and best performance.

## Lowering the Roll Bar

**Important:** Lower the roll bar only when absolutely necessary.

1. To lower the roll bar, apply forward pressure to the upper part of the roll bar.
2. Pull both knobs out and rotate them 90 degrees so they are not engaged ([Figure 9](#)).
3. Lower the roll bar to the down position ([Figure 9](#)).

# Using the Safety-Interlock System

## ⚠ WARNING

If the safety-interlock switches are disconnected or damaged, the machine could operate unexpectedly, causing personal injury.

- Do not tamper with the interlock switches.
- Check the operation of the interlock switches daily and replace any damaged switches before operating the machine.

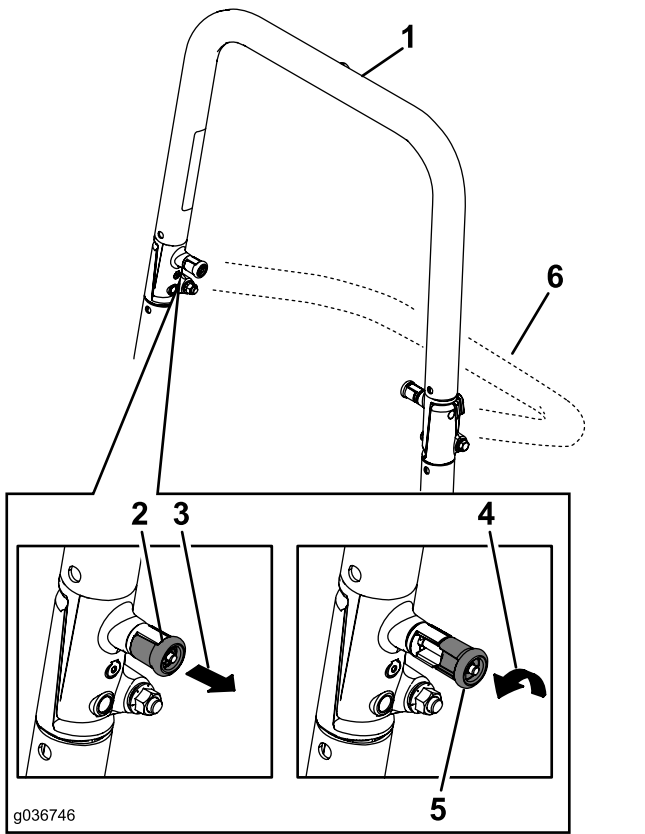

Figure 9

1. Roll bar in the upright position
2. ROPS knob in the latched position
3. Pull the ROPS knob out.
4. Rotate the ROPS knob 90 degrees.
5. ROPS knob in the unlatched position
6. Roll bar in the folded position

## Raising the Roll Bar

**Important:** Always use the seat belt with the roll bar in the raised position.

1. Raise the roll bar to the operating position and rotate the knobs until they move partially into the grooves (Figure 9).
2. Raise the roll bar to the full upright position while pushing on the upper roll bar so that the pins snap into position when the holes align with the pins (Figure 9).
3. Push on the roll bar and ensure that both pins are engaged.

## Understanding the Safety-Interlock System

The safety-interlock system is designed to prevent the engine from starting unless:

- The blade-control switch (PTO) is disengaged.
- The motion-control levers are in the NEUTRAL-LOCK position.
- The parking brake is engaged.

The safety-interlock system is also designed to shut off the engine when the traction controls are moved from the locked position with the parking brake engaged or if you rise from the seat when the PTO is engaged.

The hour meter has symbols to notify the user when the interlock component is in the correct position. When the component is in the correct position, a triangle lights up in the corresponding square.

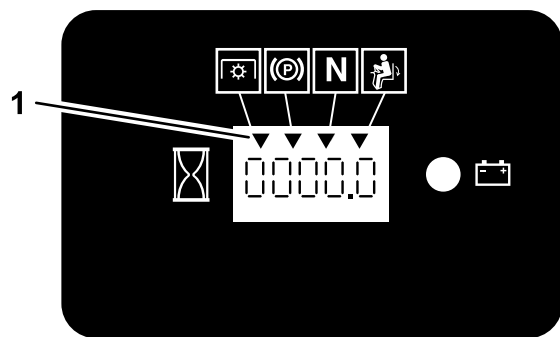

Figure 10

1. Triangles light up when the interlock components are in the correct position

# Testing the Safety-Interlock System

**Service Interval:** Before each use or daily

Test the safety-interlock system before you use the machine each time. If the safety system does not operate as described below, have an Authorized Service Dealer repair the safety system immediately.

1. Sit on the seat, engage the parking brake, and move the blade-control switch (PTO) to the ON position. Try starting the engine; the engine should not crank.
2. Sit on the seat, engage the parking brake, and move the blade-control switch (PTO) to the OFF position. Move either motion-control lever (out of the NEUTRAL-LOCK position). Try starting the engine; the engine should not crank. Repeat for other control lever.
3. Sit on the seat, engage the parking brake, move the blade-control switch (PTO) to the OFF position, and move the motion-control levers to the NEUTRAL-LOCK position. Start the engine. While the engine is running, disengage the parking brake, engage the blade-control switch (PTO), and rise slightly from the seat; the engine should shut off.
4. Sit on the seat, engage the parking brake, move the blade-control switch (PTO) to the OFF position, and move the motion-control levers to NEUTRAL-LOCK position. Start the engine. While the engine is running, center either motion-control lever and move it forward or reverse; the engine should shut off. Repeat for other motion-control lever.
5. Sit on the seat, disengage the parking brake, move the blade-control switch (PTO) to the OFF position, and move the motion-control levers to NEUTRAL-LOCK position. Try starting the engine; the engine should not crank.

# Positioning the Seat

The seat can move forward and backward. Position the seat where you have the best control of the machine and are most comfortable (Figure 11).

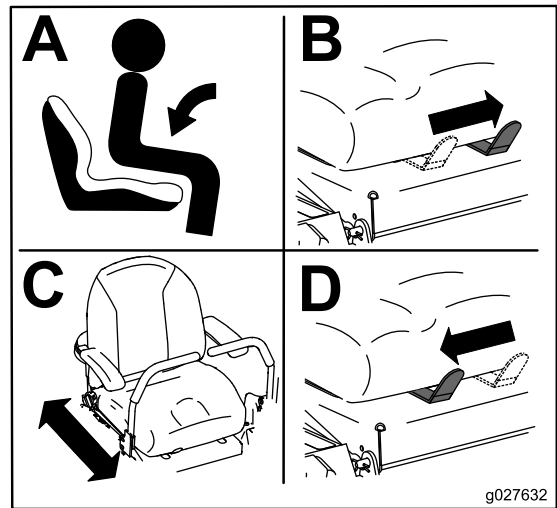

**Figure 11**

g027632

# Adjusting the MyRide™ Suspension System

The MyRide™ suspension system adjusts to provide a smooth and comfortable ride. You can adjust the rear 2-shock assemblies to quickly and easily change the suspension system. Position the suspension system where you are most comfortable.

## Adjusting the Rear-Shock Assemblies

The slots for the rear-shock assemblies have detent positions for reference. You can position the rear-shock assemblies anywhere in the slot, not just in the detent positions.

The following graphic shows the position for a soft or firm ride and the different detent positions (Figure 12).

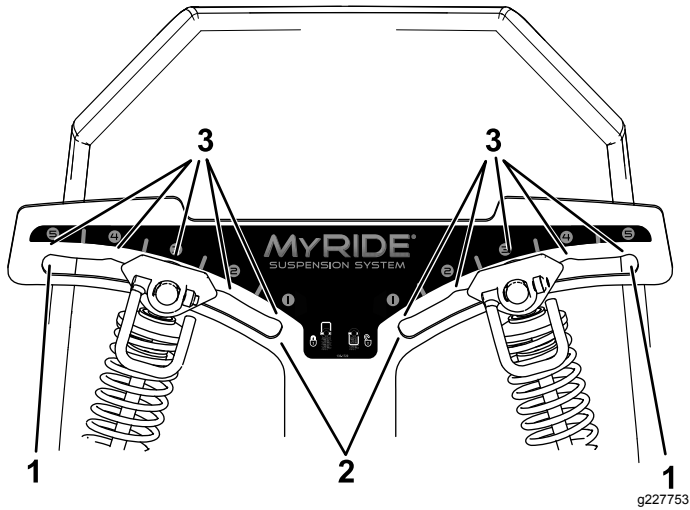
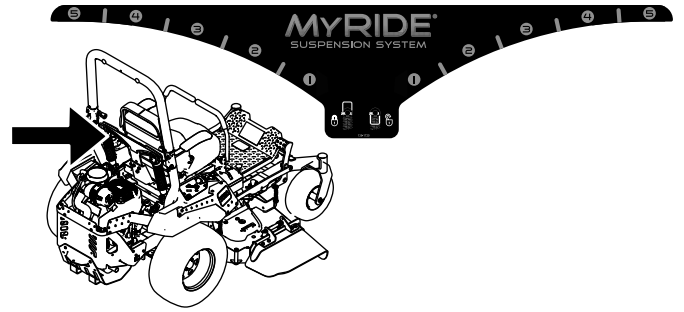

Figure 12

- 1. Firmest position
- 2. Softest position
- 3. Detents in the slots

**Note:** Ensure that the left and right rear-shock assemblies are always adjusted to the same positions.

Adjust the rear-shock assemblies (Figure 13).



g227752

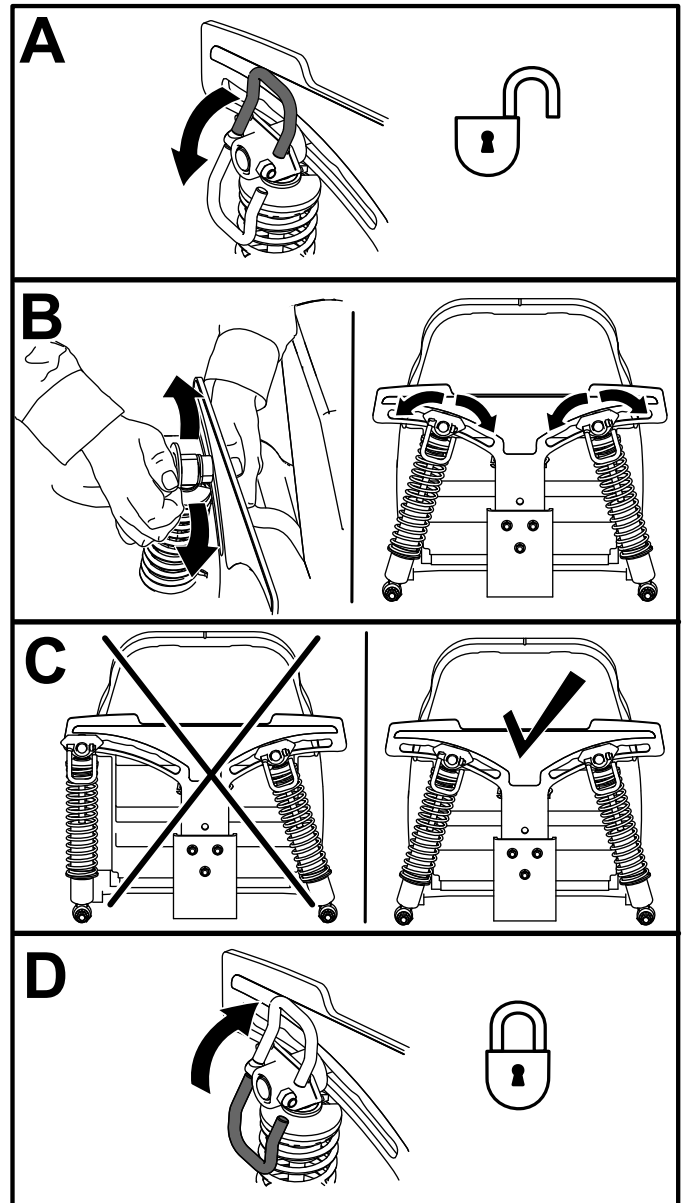

g227751

Figure 13

# Using Attachments and Accessories

Use only Toro approved attachments and accessories.

If more than one accessory-mount kit (i.e., bucket kit or universal mount kit) is added to any of the 4 locations shown in [Figure 14](#), add a front-weight kit. Contact your Authorized Service Dealer for the front-weight kit.

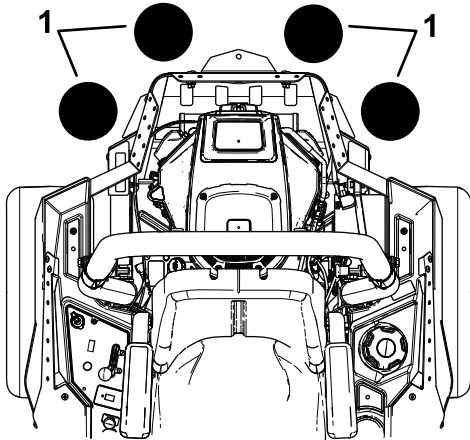

Figure 14

g037417

1. Add a front-weight kit when 2 or more accessory-mount kits are installed at these positions.

---

## During Operation

### During Operation Safety

#### General Safety

- The owner/operator can prevent and is responsible for accidents that may cause personal injury or property damage.
- Wear appropriate clothing, including eye protection; long pants; slip-resistant, substantial footwear; and hearing protection. Tie back long hair and do not wear loose jewelry.
- Do not operate the machine while ill, tired, or under the influence of alcohol or drugs.
- Never carry passengers on the machine and keep bystanders and pets away from the machine during operation.
- Operate the machine only in good visibility to avoid holes or hidden hazards.
- Avoid mowing on wet grass. Reduced traction could cause the machine to slide.
- Ensure that all drives are in neutral, the parking brake is engaged, and you are in the operating position before you start the engine.

- Keep your hands and feet away from the cutting units. Keep clear of the discharge opening at all times.
- Look behind and down before backing up to be sure of a clear path.
- Use care when approaching blind corners, shrubs, trees, or other objects that may obscure your vision.
- Do not mow near drop-offs, ditches, or embankments. The machine could suddenly roll over if a wheel goes over the edge or if the edge gives way.
- Stop the blades whenever you are not mowing.
- Stop the machine, shut off the engine, remove the key, and inspect the blades after striking an object or if there is an abnormal vibration in the machine. Make all necessary repairs before resuming operation.
- Slow down and use caution when making turns and crossing roads and sidewalks with the machine. Always yield the right-of-way.
- Disengage the drive to the cutting unit, shut off the engine, and remove the key before adjusting the height of cut (unless you can adjust it from the operating position).
- Never run an engine in an area where exhaust gases are enclosed.
- Never leave a running machine unattended.
- Before leaving the operating position (including to empty the catchers or to unclog the chute), do the following:
  - Stop the machine on level ground.
  - Disengage the power takeoff and lower the attachments.
  - Engage the parking brake.
  - Shut off the engine and remove the key.
  - Wait for all moving parts to stop.
- Do not operate the machine when there is the risk of lightning.
- Do not use the machine as a towing vehicle unless it has a hitch installed.
- Do not change the governor speed or overspeed the engine.
- Use only accessories and attachments approved by Toro.
- This machine produces sound levels in excess of 85 dBA at the operator's ear and can cause hearing loss through extended periods of exposure.

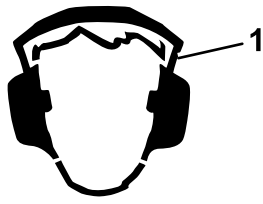

Figure 15

g229846

1. Wear hearing protection.

## Rollover Protection System (ROPS) Safety

- **Do not** remove the roll bar from the machine.
- Ensure that the seat belt is attached and that you can release it quickly in an emergency.
- Always wear your seat belt when the roll bar is up.
- Check carefully for overhead obstructions and do not contact them.
- Keep the roll bar in safe operating condition by thoroughly inspecting it periodically for damage and keeping all the mounting fasteners tight.
- Replace a damaged roll bar. Do not repair or alter it.

## Slope Safety

- Slopes are a major factor related to loss of control and rollover accidents, which can result in severe injury or death. The operator is responsible for safe slope operation. Operating the machine on any slope requires extra caution. Before using the machine on a slope, do the following:
  - Review and understand the slope instructions in the manual and on the machine.
  - Use an angle indicator to determine the approximate slope angle of the area.
  - Never operate on slopes greater than 15 degrees.
  - Evaluate the site conditions of the day to determine if the slope is safe for machine operation. Use common sense and good judgment when performing this evaluation. Changes in the terrain, such as moisture, can quickly affect the operation of the machine on a slope.
- Identify hazards at the base of the slope. Do not operate the machine near drop-offs, ditches, embankments, water, or other hazards. The machine could suddenly roll over if a wheel goes over the edge or the edge collapses. Keep a safe distance (twice the width of the machine) between the machine and any hazard. Use a walk-behind

machine or a hand trimmer to mow the grass in these areas.

- Avoid starting, stopping, or turning the machine on slopes. Avoid making sudden changes in speed or direction; turn slowly and gradually.
- Do not operate a machine under any conditions where traction, steering, or stability is in question. Be aware that operating the machine on wet grass, across slopes, or downhill may cause the machine to lose traction. Loss of traction to the drive wheels may result in sliding and a loss of braking and steering. The machine can slide even if the drive wheels are stopped.
- Remove or mark obstacles such as ditches, holes, ruts, bumps, rocks, or other hidden hazards. Tall grass can hide obstacles. Uneven terrain could overturn the machine.
- Use extra care while operating with accessories or attachments, such as grass-collection systems. These can change the stability of the machine and cause a loss of control. Follow directions for counterweights.
- If possible, keep the deck lowered to the ground while operating on slopes. Raising the deck while operating on slopes can cause the machine to become unstable.

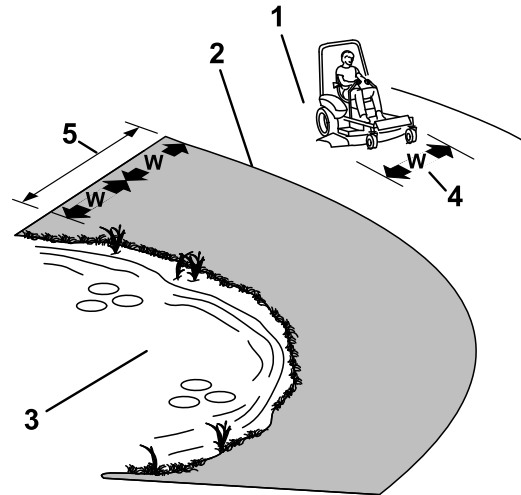

Figure 16

g221745

1. Safe Zone—use the machine here on slopes less than 15 degrees or flat areas.
2. Danger Zone—use a walk-behind mower and/or a hand trimmer on slopes greater than 15 degrees and near drop-offs or water.
3. Water
4. W=width of the machine
5. Keep a safe distance (twice the width of the machine) between the machine and any hazard.

# Entering the Operator's Position

Use the mower deck as a step to get into the operator's position (Figure 17).

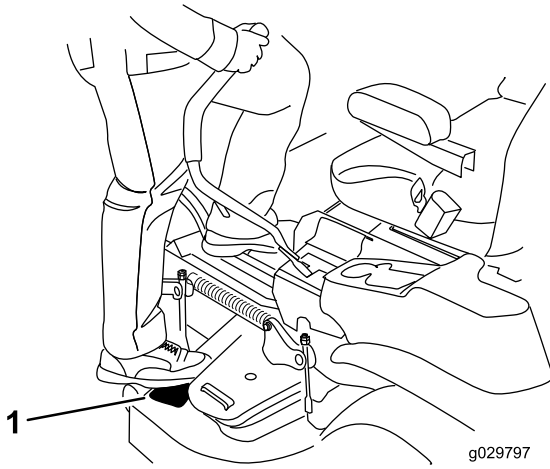

Figure 17

# Disengaging the Parking Brake

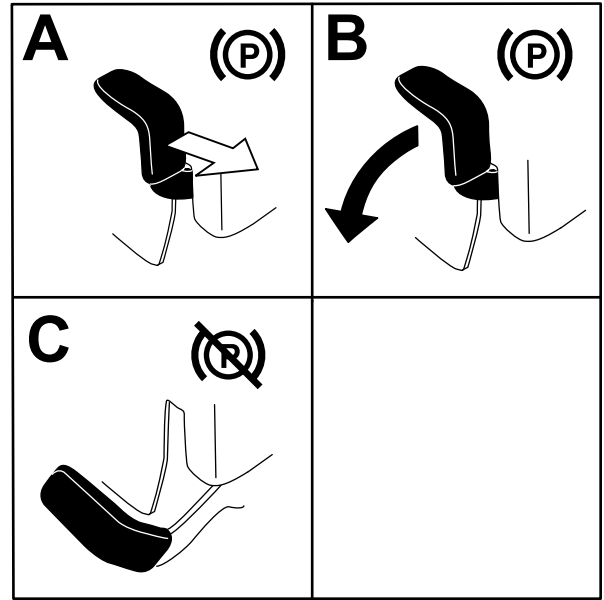

Figure 19

# Operating the Parking Brake

Always engage the parking brake when you stop the machine or leave it unattended.

## Engaging the Parking Brake

Park the machine on a level surface.

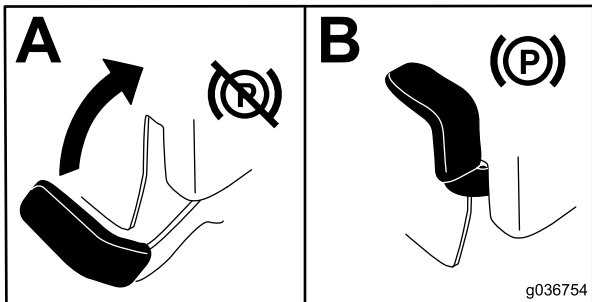

Figure 18

# Operating the Mower Blade-Control Switch (PTO)

The blade-control switch (PTO) starts and stops the mower blades and any powered attachments.

## Engaging the Blade-Control Switch (PTO)

**Note:** Engaging the blade-control switch (PTO) with the throttle position at half or less causes excessive wear to the drive belts.

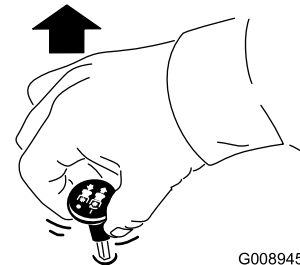
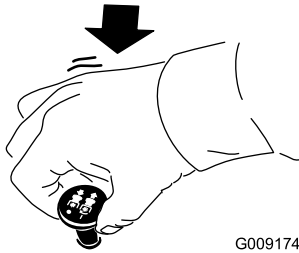

Figure 20

## Disengaging the Blade-Control Switch (PTO)



G009174

g009174

Figure 21

---

## Operating the Throttle

You can move the throttle control between FAST and SLOW positions (Figure 22).

Always use the FAST position when engaging the PTO.

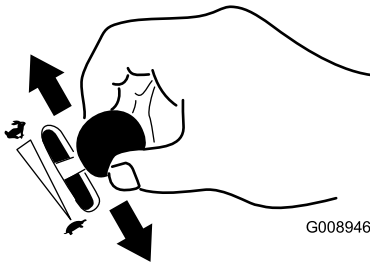

G008946

g008946

Figure 22

## Operating the Choke

Use the choke to start a cold engine.

1. Pull up the choke knob to engage the choke before using the key switch (Figure 23).
2. Push down the choke knob to disengage the choke after the engine has started (Figure 23).

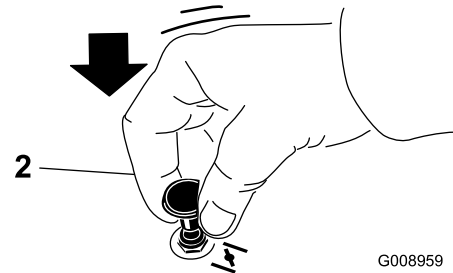
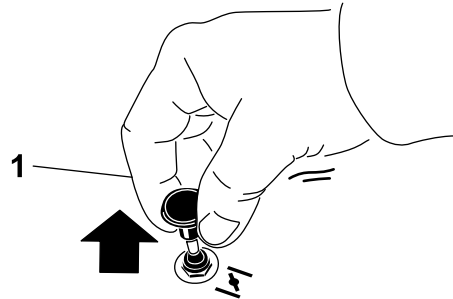

G008959

g008959

Figure 23

1. ON position

2. OFF position

# Starting the Engine

**Note:** A warm or hot engine may not require choking.

**Important:** Do not engage the starter for more than 5 seconds at a time. Engaging the starter motor for more than 5 seconds can damage the starter motor. If the engine fails to start, wait 10 seconds before operating the engine starter again.

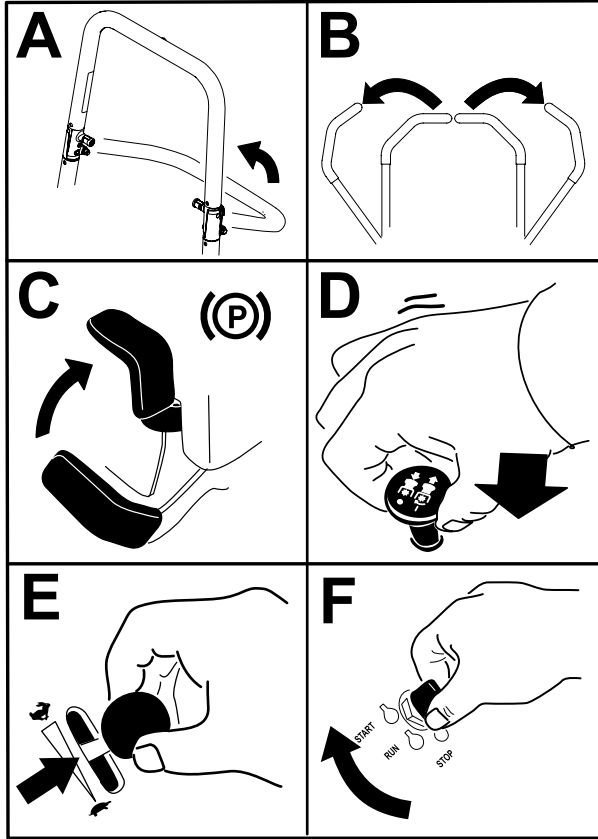

Figure 24

g227548

# Shutting Off the Engine

## ⚠ CAUTION

Children or bystanders may be injured if they move or attempt to operate the machine while it is unattended.

Always remove the key and engage the parking brake when leaving the machine unattended.

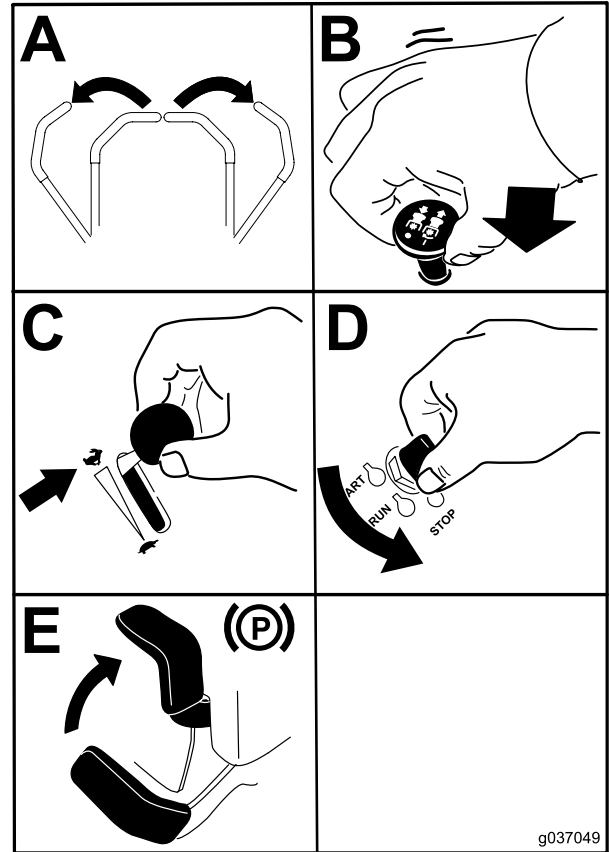

Figure 25

g037049

g037049

**Important:** Make sure that the fuel-shutoff valve is closed before transporting or storing the machine, as fuel leakage may occur. Engage the parking brake before transporting. Make sure that you remove the key as the fuel pump may run and cause the battery to lose charge.

# Using the Motion-Control Levers

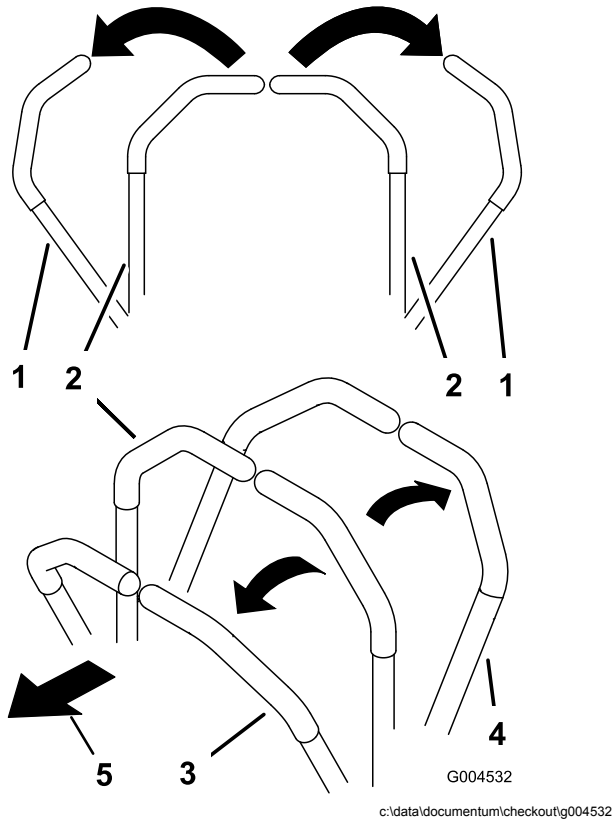

Figure 26

1. Motion-control lever—NEUTRAL-LOCK position
2. Center, unlocked position
3. Forward
4. Backward
5. Front of machine

## Driving the Machine

The drive wheels turn independently, powered by hydraulic motors on each axle. You can turn 1 side in reverse while you turn the other forward, causing the machine to spin rather than turn. This greatly improves the machine maneuverability but may require some time for you to adapt to how it moves.

The throttle control regulates the engine speed as measured in rpm (revolutions per minute). Place the throttle control in the FAST position for best performance. Always operate in the full throttle position when mowing.

## ⚠ WARNING

The machine can spin very rapidly. You may lose control of the machine and cause personal injury or damage to the machine.

- Use caution when making turns.
- Slow the machine down before making sharp turns.

## Driving Forward

**Note:** The engine shuts off when you move the traction-control with the parking brake engaged.

To stop the machine, pull the motion-control levers to the NEUTRAL position.

1. Disengage the parking brake; refer to [Disengaging the Parking Brake \(page 22\)](#).
2. Move the levers to the center, unlocked position.
3. To go forward, slowly push the motion-control levers forward ([Figure 27](#)).

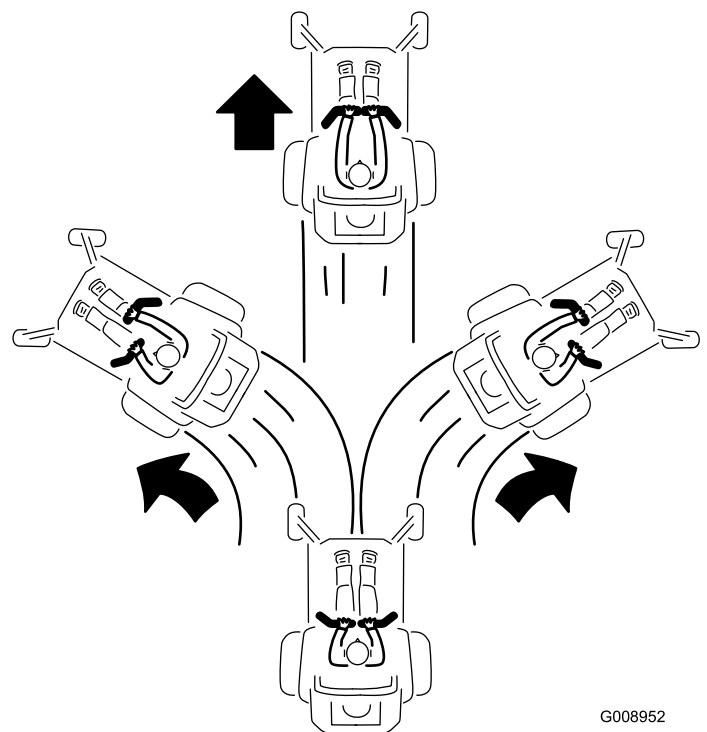
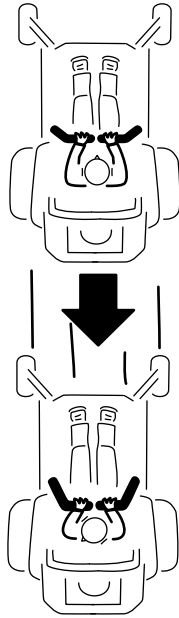

Figure 27

## Driving Backward

1. Move the levers to the center, unlocked position.
2. To go backward, slowly pull the motion-control levers rearward (Figure 28).



G008953

g008953

Figure 28

## Adjusting the Height of Cut

### Using the Transport Lock

The transport lock has 2 positions, and is used with the deck-lift pedal. There is a LOCK position and an UNLOCK position for the transport position of the mower deck (Figure 29).

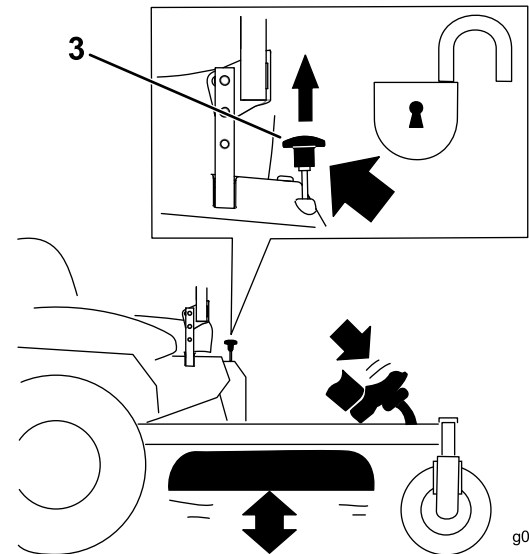
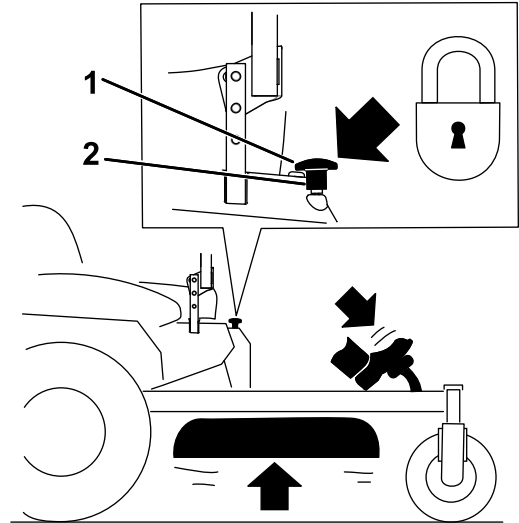

g037050

g037050

Figure 29

Transport-Lock Positions

1. Transport lock knob
2. LOCK position—The mower deck locks into the transport position.
3. UNLOCK position—The mower deck does not lock into the transport position.

## Adjusting the Height-of-Cut Pin

Adjust the height-of-cut from 38 to 127 mm (1-1/2 to 5 inches) in 6 mm (1/4 inch) increments by moving the height-of-cut pin into different hole locations.

1. Move the transport lock to the LOCK position.
2. Push on the deck-lift pedal with your foot and raise the mower deck to the TRANSPORT position (also the 127 mm or 5 inch cutting-height position) as shown in [Figure 30](#).
3. Remove the pin from the height-of-cut bracket ([Figure 30](#)).
4. Select a hole in the height-of-cut bracket corresponding to the height-of-cut desired, and insert the pin ([Figure 30](#)).
5. Push on the deck lift, pull up on the transport lock knob, and slowly lower the mower deck.

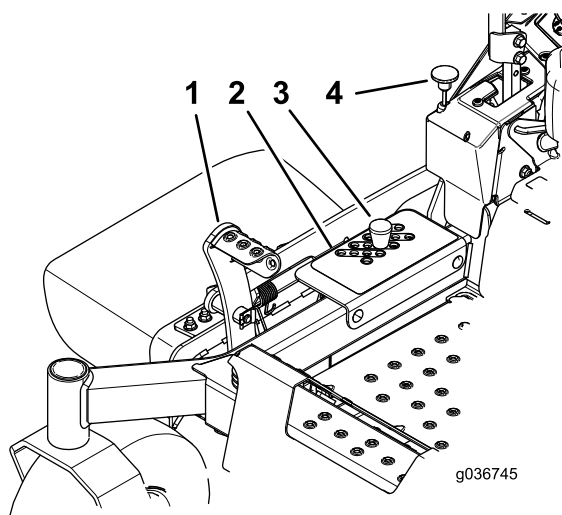

**Figure 30**

- |                        |                        |
|------------------------|------------------------|
| 1. Deck-lift pedal     | 3. Height-of-cut pin   |
| 2. Height-of-cut holes | 4. Transport lock knob |

## Adjusting the Anti-Scalp Rollers

Whenever you change the height of cut, adjust the height of the anti-scalp rollers.

**Note:** Adjust the anti-scalp rollers so that the rollers do not touch the ground in normal, flat mowing areas.

1. Park the machine on a level surface, disengage the blade-control switch and engage the parking brake; refer to [Engaging the Parking Brake](#) (page 22).
2. Shut off the engine, remove the key, and wait for all moving parts to stop before leaving the operating position.
3. Adjust the anti-scalp rollers as shown in [Figure 31](#).

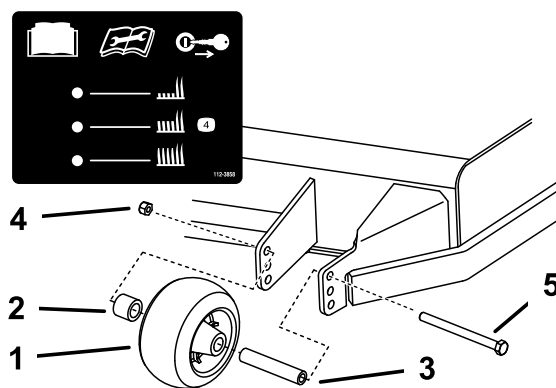

**Figure 31**

- |                      |               |
|----------------------|---------------|
| 1. Anti-scalp roller | 4. Flange nut |
| 2. Spacer            | 5. Bolt       |
| 3. Bushing           |               |

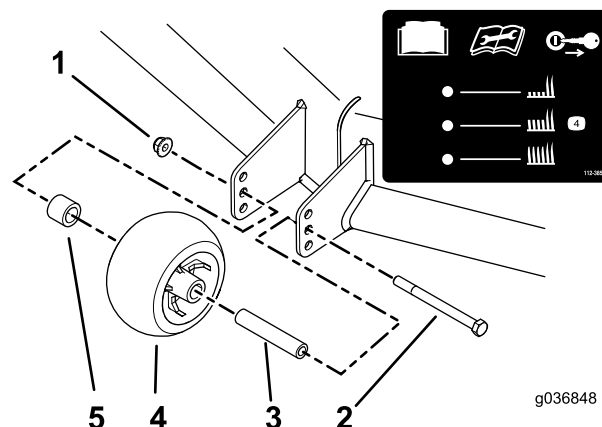

**Figure 32**

- |               |                      |
|---------------|----------------------|
| 1. Flange nut | 4. Anti-scalp roller |
| 2. Bolt       | 5. Spacer            |
| 3. Bushing    |                      |

## Using the Side Discharge

The mower has a hinged grass deflector that disperses clippings to the side and down toward the turf.

### **▲ DANGER**

**Without a grass deflector, discharge cover, or a complete grass-catcher assembly mounted in place, you and others are exposed to blade contact and thrown debris. Contact with rotating mower blade(s) and thrown debris will cause injury or death.**

- **Never remove the grass deflector from the mower deck because the grass deflector routes material down toward the turf. If the grass deflector is ever damaged, replace it immediately.**
- **Never put your hands or feet under the mower deck.**
- **Never try to clear the discharge area or mower blades unless you move the blade-control switch (PTO) to the OFF position, rotate the key switch to the OFF position, and remove the key from the key switch.**
- **Make sure that the grass deflector is in the down position.**

## Operating Tips

### Using the Fast Throttle Setting

For best mowing and maximum air circulation, operate the engine at the FAST position. Air is required to thoroughly cut grass clippings, so do not set the height-of-cut so low as to totally surround the mower deck in uncut grass. Always try to have 1 side of the mower deck free from uncut grass, which allows air to be drawn into the mower deck.

### Cutting a Lawn for the First Time

Cut grass slightly longer than normal to ensure that the cutting height of the mower deck does not scalp any uneven ground. However, the cutting height used in the past is generally the best one to use. When cutting grass longer than 15 cm (6 inches) tall, you may want to cut the lawn twice to ensure an acceptable quality of cut.

### Cutting a Third of the Grass Blade

It is best to cut only about a third of the grass blade. Cutting more than that is not recommended unless

grass is sparse, or it is late fall when grass grows more slowly.

## Alternating the Mowing Direction

Alternate the mowing direction to keep the grass standing straight. This also helps disperse clippings, which enhances decomposition and fertilization.

## Mowing at Correct Intervals

Grass grows at different rates at different times of the year. To maintain the same cutting height, mow more often in early spring. As the grass growth rate slows in mid summer, mow less frequently. If you cannot mow for an extended period, first mow at a high cutting height, then mow again 2 days later at a lower height setting.

## Using a Slower Cutting Speed

To improve cut quality, use a slower ground speed in certain conditions.

## Avoiding Cutting Too Low

When mowing uneven turf, raise the cutting height to avoid scalping the turf.

## Stopping the Machine

If you must stop the forward motion of the machine while mowing, a clump of grass clippings may drop onto your lawn. To avoid this, move onto a previously cut area with the blades engaged or you can disengage the mower deck while moving forward.

## Keeping the Underside of the Mower Deck Clean

Clean clippings and dirt from the underside of the mower deck after each use. If grass and dirt build up inside the mower deck, cutting quality will eventually become unsatisfactory.

## Maintaining the Blade(s)

Maintain a sharp blade throughout the cutting season because a sharp blade cuts cleanly without tearing or shredding the grass blades. Tearing and shredding turns grass brown at the edges, which slows growth and increases the chance of disease. Check the mower blades after each use for sharpness, and for any wear or damage. File down any nicks and sharpen the blades as necessary. If a blade is damaged or worn, replace it immediately with a genuine Toro replacement blade.

# After Operation

## After Operation Safety

### General Safety

- Park the machine on a level surface; engage the parking brake; shut off the engine; remove the key; and wait for all movement to stop before leaving the machine.
- Clean grass and debris from the cutting units, drives, mufflers, cooling screens, and engine to help prevent fires. Clean up oil or fuel spills.
- Shut off the fuel while storing or transporting the machine.
- Disengage the drive to the attachment whenever you are transporting or not using the machine.
- Allow the engine to cool before storing the machine in any enclosure.
- Maintain and clean the seat belt(s) as necessary.
- Never store the machine or fuel container where there is an open flame, spark, or pilot light, such as on a water heater or on other appliances.

## Using the Fuel-Shutoff Valve

Close the fuel-shutoff valve for transport, maintenance, and storage (Figure 33).

Ensure that the fuel-shutoff valve is open when starting the engine.

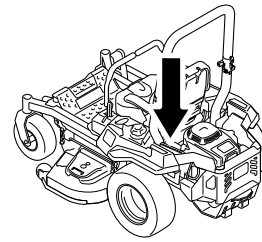

g036849

g036849

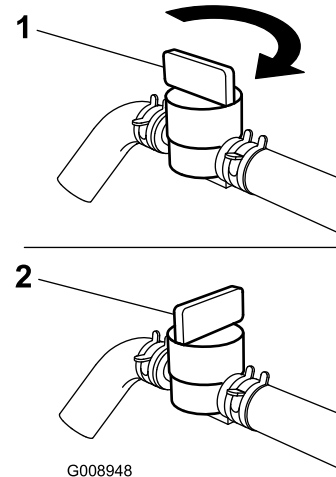

G008948

g008948

**Figure 33**

1. ON position

2. OFF position

## Using the Drive-Wheel Release Valves

### **⚠ WARNING**

Hands may become entangled in the rotating drive components below the engine deck, which could result in serious injury.

Shut off the engine, remove the key, and allow all moving parts to stop before accessing the drive-wheel release valves.

### **⚠ WARNING**

The engine and hydraulic-drive units can become very hot. Touching a hot engine or hydraulic-drive units can cause severe burns.

Allow the engine and hydraulic-drive units to cool completely before accessing the drive-wheel release valves.

The drive-wheel release valves are located on the left and right sides underneath the engine deck.

1. Park the machine on a level surface, disengage the blade-control switch, and engage the parking brake.

2. Shut off the engine, remove the key, and wait for all moving parts to stop before leaving the operating position.
3. Locate the bypass levers behind the seat, down on the left and right side of the frame.
4. To push the machine, move both bypass knobs rearward and lock them into place (Figure 34).
5. Disengage the parking brake before pushing the machine.

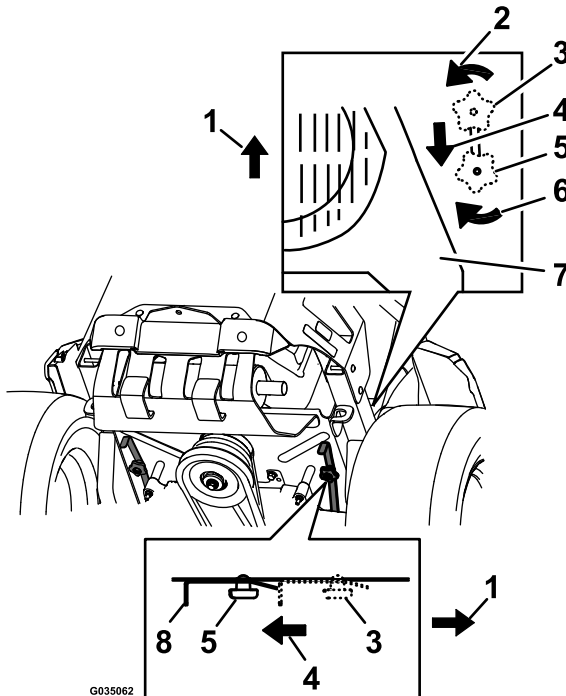

Figure 34

1. Front of the machine
2. Rotate bypass release knob counterclockwise to loosen.
3. Lever position for operating the machine
4. Pull the lever in this direction to push the machine.
5. Lever position for pushing the machine
6. Rotate the bypass-release knob clockwise to tighten.
7. Engine
8. Release lever

6. To run the machine, move the bypass knobs to the FORWARD position and lock them into place (Figure 34).

## Transporting the Machine

Use a heavy-duty trailer or truck to transport the machine. Use a full-width ramp. Ensure that the trailer or truck has all the necessary brakes, lighting, and marking as required by law. Please carefully read all the safety instructions. Knowing this information could help you or bystanders avoid injury. Refer to your local ordinances for trailer and tie-down requirements.

### ⚠ WARNING

Driving on the street or roadway without turn signals, lights, reflective markings, or a slow-moving-vehicle emblem is dangerous and can lead to accidents, causing personal injury.

Do not drive the machine on a public street or roadway.

## Selecting a Trailer

### ⚠ WARNING

Loading a machine onto a trailer or truck increases the possibility of tip-over and could cause serious injury or death (Figure 35).

- Use only a full-width ramp; do not use individual ramps for each side of the machine.
- Do not exceed a 15-degree angle between the ramp and the ground or between the ramp and the trailer or truck.
- Ensure that the length of ramp is at least 4 times as long as the height of the trailer or truck bed to the ground. This ensures that ramp angle does not exceed 15 degrees on flat ground.

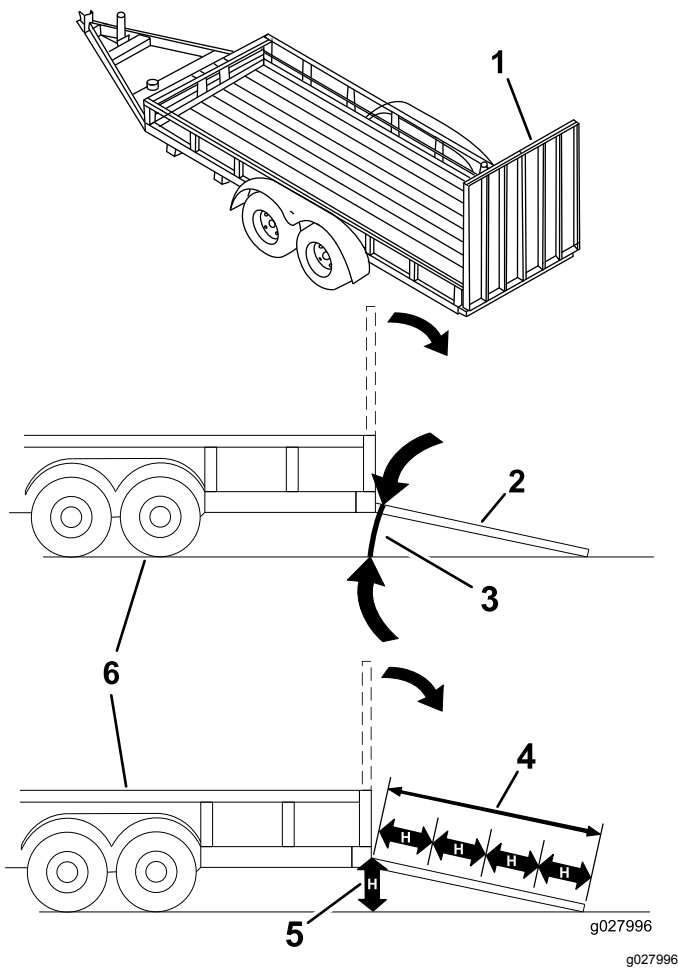

Figure 35

- |   |   |
|---|---|
| 1. Full-width ramp in stowed position               | 4. Ramp is at least 4 times as long as the height of the trailer or truck bed to the ground |
| 2. Side view of full-width ramp in loading position | 5. H=height of the trailer or truck bed to the ground                                       |
| 3. Not greater than 15 degrees                      | 6. Trailer  |

## Loading the Machine

### ⚠ WARNING

Loading a machine onto a trailer or truck increases the possibility of tip-over and could cause serious injury or death.

- Use extreme caution when operating a machine on a ramp.
- Back the machine up the ramp and drive it forward down the ramp.
- Avoid sudden acceleration or deceleration while driving the machine on a ramp as this could cause a loss of control or a tip-over situation.

1. If using a trailer, connect it to the towing vehicle and connect the safety chains.
2. If applicable, connect the trailer brakes and lights.
3. Lower the ramp, ensuring that the angle between the ramp and the ground does not exceed 15 degrees (Figure 35).
4. Back the machine up the ramp (Figure 36).

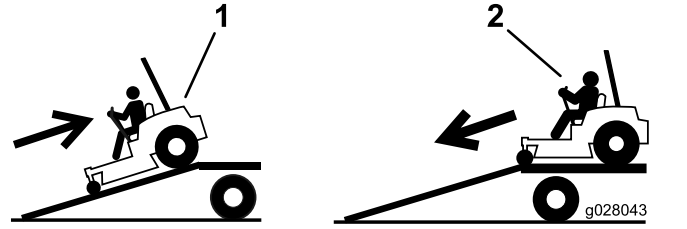

Figure 36

1. Back the machine up the ramp.
2. Drive the machine forward down the ramp.

5. Shut off the engine, remove the key, and engage the parking brake.
6. Tie down the machine near the front caster wheels and the rear bumper with straps, chains, cable, or ropes (Figure 37). Refer to local regulations for tie-down requirements.

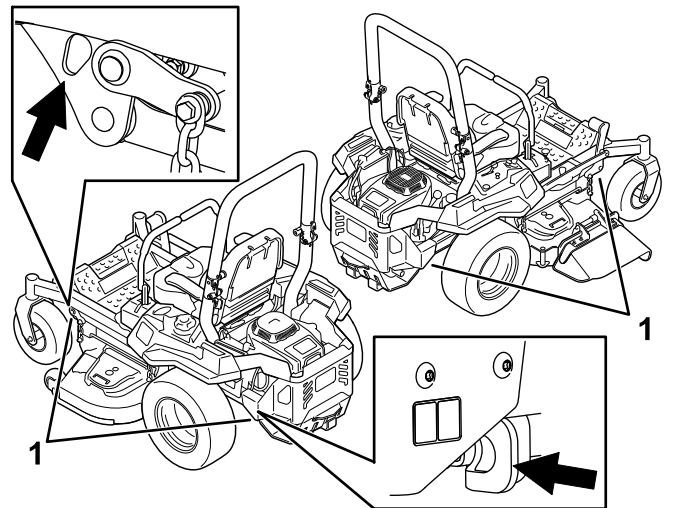

Figure 37

1. Tie-down loops

## Unloading the Machine

1. Lower the ramp, ensuring that the angle between the ramp and the ground does not exceed 15 degrees (Figure 35).
2. Drive the machine forward down the ramp (Figure 36).

# Maintenance

## Recommended Maintenance Schedule(s)

Maintenance Service Interval	Maintenance Procedure
After the first 5 hours	<ul style="list-style-type: none"> <li>• Change the engine oil and filter.</li> </ul>
After the first 75 hours	<ul style="list-style-type: none"> <li>• Change the hydraulic-system filters and fluid.</li> </ul>
Before each use or daily	<ul style="list-style-type: none"> <li>• Check the safety-interlock system.</li> <li>• Check the air cleaner for dirty, loose, or damaged parts.</li> <li>• Check the engine-oil level.</li> <li>• Clean the air intake screen.</li> <li>• Check the seat belt.</li> <li>• Check the roll bar knobs.</li> <li>• Clean the engine screen and the area around the engine.</li> <li>• Clean around the engine-exhaust system.</li> <li>• Check the hydraulic fluid level in the expansion tank.</li> <li>• Inspect the blades.</li> <li>• Clean the mower deck.</li> <li>• Clean the suspension system.</li> </ul>
Every 25 hours	<ul style="list-style-type: none"> <li>• Grease the front caster axles. (more often in dirty or dusty conditions).</li> <li>• Clean the air-cleaner foam element (more often in dusty, dirty conditions).</li> </ul>
Every 50 hours	<ul style="list-style-type: none"> <li>• Grease the pump-idler pivot.</li> <li>• Check the spark arrester (if equipped).</li> <li>• Check the tire pressure.</li> <li>• Inspect the belts for cracks and wear.</li> </ul>
Every 100 hours	<ul style="list-style-type: none"> <li>• Replace the air-cleaner foam element (more often in dusty, dirty conditions).</li> <li>• Clean the paper air-cleaner element (more often in dirty or dusty conditions).</li> <li>• Change the engine oil and oil filter (more often in dirty or dusty conditions).</li> <li>• Check the spark plug(s).</li> </ul>
Every 200 hours	<ul style="list-style-type: none"> <li>• Replace the paper air-cleaner element (more often in dirty or dusty conditions).</li> <li>• Replace the spark plug(s).</li> </ul>
Every 250 hours	<ul style="list-style-type: none"> <li>• After the initial change—change the hydraulic-system filters and fluid when using Mobil 1 15W50 fluid (change it more often under severe conditions).</li> </ul>
Every 500 hours	<ul style="list-style-type: none"> <li>• Replace the emissions-air intake filter.</li> <li>• Replace the fuel filter (more often in dusty, dirty conditions).</li> <li>• Check the parking brake adjustment.</li> <li>• After the initial change—change the hydraulic-system filters and fluid when using Toro® HYPR-OIL™ 500 fluid (change it more often under severe conditions).</li> </ul>
Monthly	<ul style="list-style-type: none"> <li>• Check the battery charge.</li> </ul>
Yearly or before storage	<ul style="list-style-type: none"> <li>• Paint chipped surfaces.</li> <li>• Check all maintenance procedures listed above before storage.</li> </ul>

# Pre-Maintenance Procedures

## Maintenance Safety

- Before repairing the machine do the following:
  - Disengage the drives.
  - Engage the parking brake.
  - Shut off the engine and remove the key.
  - Disconnect the spark-plug wire.
- Park the machine on a level surface.
- Clean grass and debris from the cutting unit, drives, mufflers, and engine to help prevent fires.
- Clean up oil or fuel spills.
- Do not allow untrained personnel to service the machine.
- Use jack stands to support the machine and/or components when required.
- Carefully release pressure from components with stored energy.
- Disconnect the battery or remove the spark-plug wire before making any repairs. Disconnect the negative terminal first and the positive terminal last. Connect the positive terminal first and negative last.
- Use care when checking the blades. Wrap the blade(s) or wear thickly padded gloves, and use caution when servicing them. Only replace blades; do not straighten or weld them.
- Keep your hands and feet away from moving parts. If possible, do not make adjustments with the engine running.
- Keep all parts in good working condition and all hardware tightened, especially the blade-attachment bolts. Replace all worn or damaged decals.
- Never interfere with the intended function of a safety device or reduce the protection provided by a safety device. Check their proper operation regularly.
- Check the parking brake operation frequently. Adjust and service as required.

## Releasing the Mower-Deck Curtain

Loosen the top bolt of the curtain to release the mower-deck curtain and access the top of the mower deck (Figure 38). Tighten the bolt after maintenance to install the curtain.

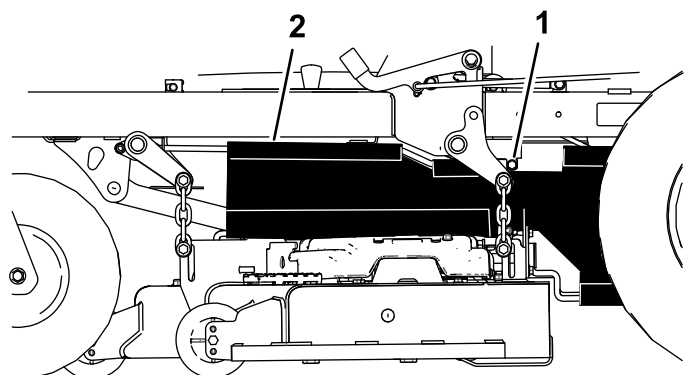

Figure 38

1. Bolt

2. Curtain

# Removing the Sheet-Metal Guard

Loosen the 2 front bolts and remove the sheet-metal guard to access the mower belts and spindles (Figure 39). Install the sheet-metal guard and tighten the bolts after maintenance.

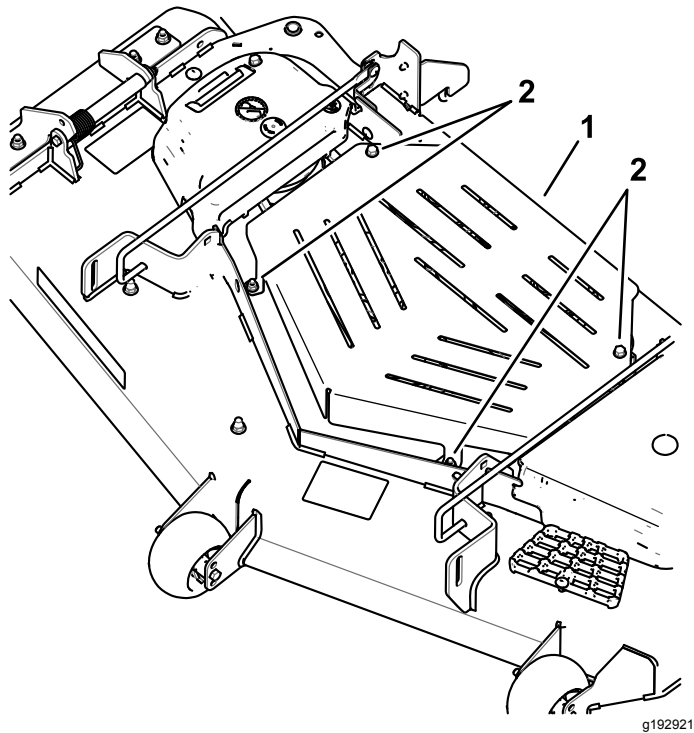

Figure 39

1. Sheet-metal guard      2. Bolt

# Lubrication

## Greasing the Machine

**Service Interval:** Every 25 hours—Grease the front caster axles. (more often in dirty or dusty conditions).

Every 50 hours—Grease the pump-idler pivot.

**Grease Type:** No. 2 lithium or molybdenum grease

1. Park the machine on a level surface, disengage the blade-control switch, and engage the parking brake; refer to [Engaging the Parking Brake](#) (page 22).
2. Shut off the engine, remove the key, and wait for all moving parts to stop before leaving the operating position.
3. Clean the grease fittings with a rag.

**Note:** Scrape any paint off the front of the fitting(s).

4. Grease the pump idler-pulley pivot with 1 or 2 pumps of grease (Figure 40).
5. Grease the front caster axles (Figure 40).

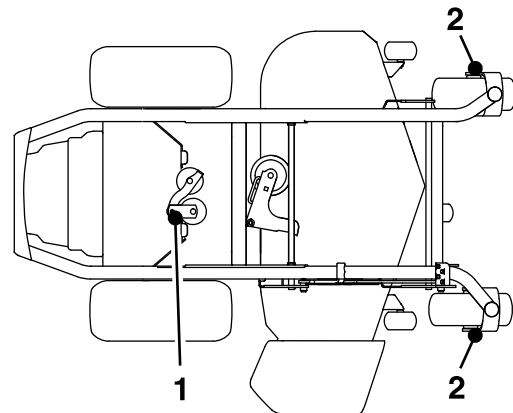

Figure 40

1. Pump-idler pivot      2. Caster axle

6. Wipe up any excess grease.

# Engine Maintenance

## Engine Safety

- Shut off the engine, and remove the key before checking the oil or adding oil to the crankcase.
- Keep your hands, feet, face, clothing, and other body parts away the muffler and other hot surfaces.

## Servicing the Air Cleaner

**Service Interval:** Before each use or daily

**Note:** Service the air cleaner more frequently (every few hours) if operating conditions are extremely dusty or sandy.

## Removing the Foam and Paper Elements

1. Park the machine on a level surface, disengage the blade-control switch (PTO), and engage the parking brake.
2. Shut off the engine, remove the key, and wait for all moving parts to stop before leaving the operating position.
3. Clean around the air-cleaner cover to prevent dirt from getting into the engine and causing damage.
4. Lift the cover and rotate the air-cleaner assembly out of the engine ([Figure 41](#)).

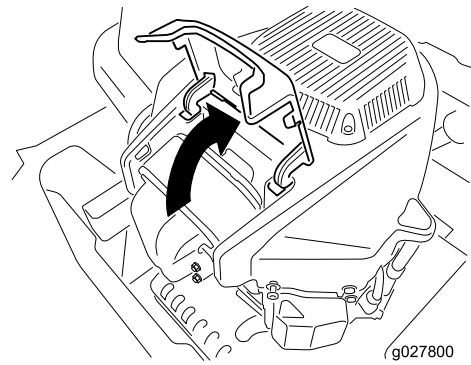

g027800

g027800

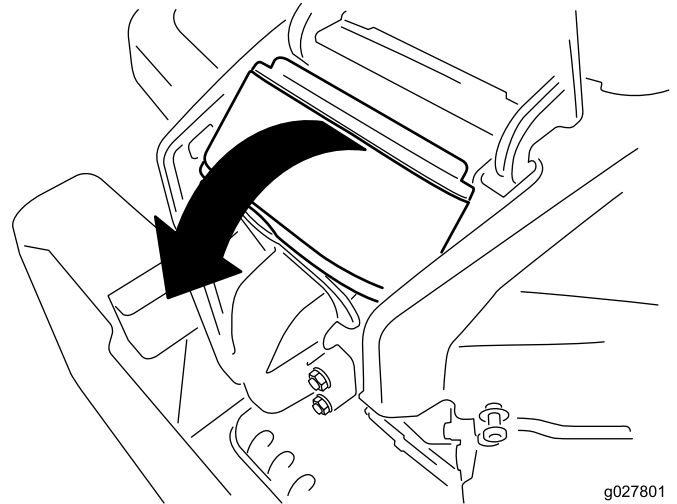

g027801

g027801

**Figure 41**

5. Separate the foam and paper elements ([Figure 42](#)).

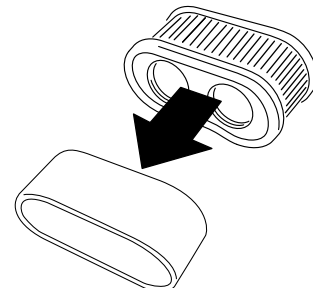

g027802

g027802

**Figure 42**

## Servicing the Foam Air-Cleaner Element

**Service Interval:** Every 25 hours/Monthly (whichever comes first)—Clean the air-cleaner foam element (more often in dusty, dirty conditions).

Every 100 hours/Yearly (whichever comes first)—Replace the air-cleaner foam element (more often in dusty, dirty conditions).

1. Wash the foam element in liquid soap and warm water. When the element is clean, rinse it thoroughly.
2. Dry the element by squeezing it in a clean cloth.

**Important:** Replace the foam element if it is torn or worn.

## Servicing the Paper Air-Cleaner Element

**Service Interval:** Every 100 hours—Clean the paper air-cleaner element (more often in dirty or dusty conditions).

Every 200 hours—Replace the paper air-cleaner element (more often in dirty or dusty conditions).

1. Clean the paper element by tapping it gently to remove dust.

**Note:** If it is very dirty, replace the paper element with a new one.

2. Inspect the element for tears, an oily film, or damage to the rubber seal.
3. Replace the paper element if it is damaged.

**Important:** Do not clean the paper filter.

## Installing the Air Cleaner

1. Install the foam element over the paper element.

**Note:** Ensure that you do not damage the elements.

2. Align the holes of the filter into the manifold ports.
3. Rotate the filter down into the chamber and fully seat it against the manifold (Figure 43).

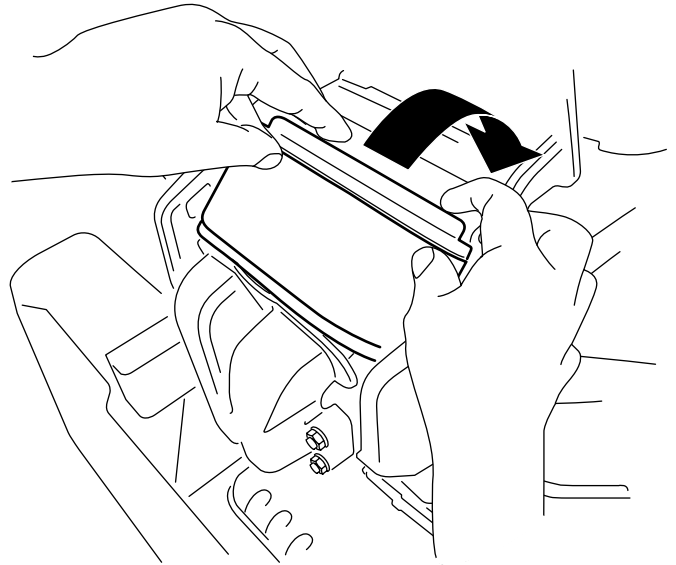

Figure 43

g228022

4. Close the cover.

# Servicing the Engine Oil

## Engine-Oil Specifications

**Oil Type:** Detergent oil (API service SF, SG, SH, SJ, or SL)

**Crankcase Capacity:** 2.4 L (81 fl oz) with oil filter

**Viscosity:** See the table below.

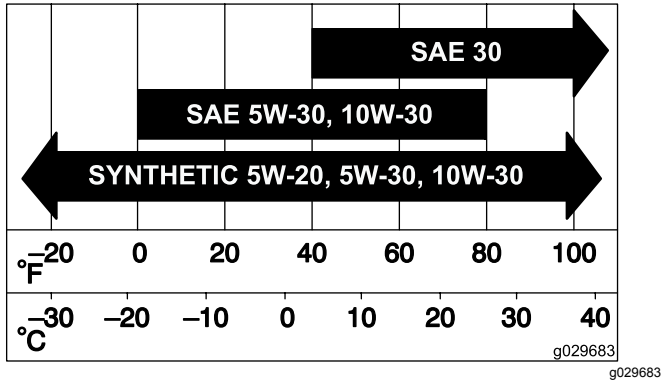

Figure 44

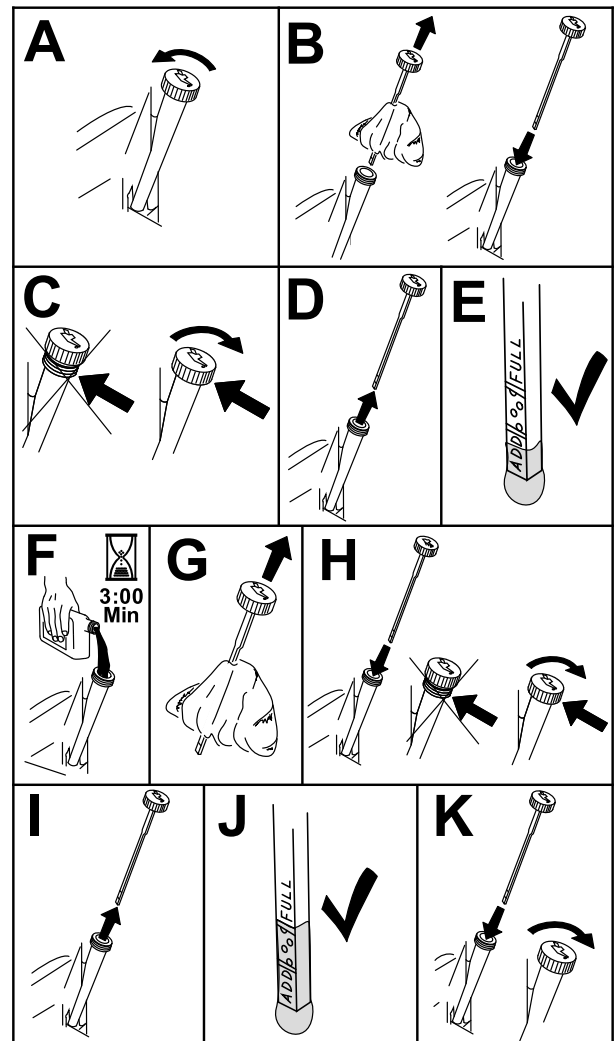

Figure 45

## Checking the Engine-Oil Level

**Service Interval:** Before each use or daily

**Note:** Check the oil when the engine is cold.

**Important:** If you overfill or underfill the engine crankcase with oil and run the engine, you may damage the engine.

1. Park the machine on a level surface, disengage the blade-control switch (PTO), and engage the parking brake.
2. Shut off the engine, remove the key, and wait for all moving parts to stop before leaving the operating position.

**Note:** Ensure that the engine is cool so that the oil has had time to drain into the sump.

3. To keep dirt, grass clippings, etc., out of the engine, clean the area around the oil-fill cap and dipstick before removing it (Figure 45).

## Changing the Engine Oil and Oil Filter

**Service Interval:** After the first 5 hours/After the first month (whichever comes first)—Change the engine oil and filter.

Every 100 hours/Yearly (whichever comes first)—Change the engine oil and oil filter (more often in dirty or dusty conditions).

1. Park the machine on a level surface to ensure that the oil drains completely.
2. Disengage the blade-control switch (PTO) and engage the parking brake.
3. Shut off the engine, remove the key, and wait for all moving parts to stop before leaving the operating position.
4. Drain the oil from the engine.

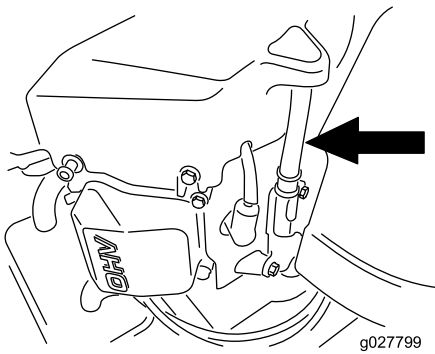

g027799

g027799

5. Change the engine-oil filter (Figure 47).

**Note:** Ensure that the oil-filter gasket touches the engine and then turn the filter an extra 3/4 turn.

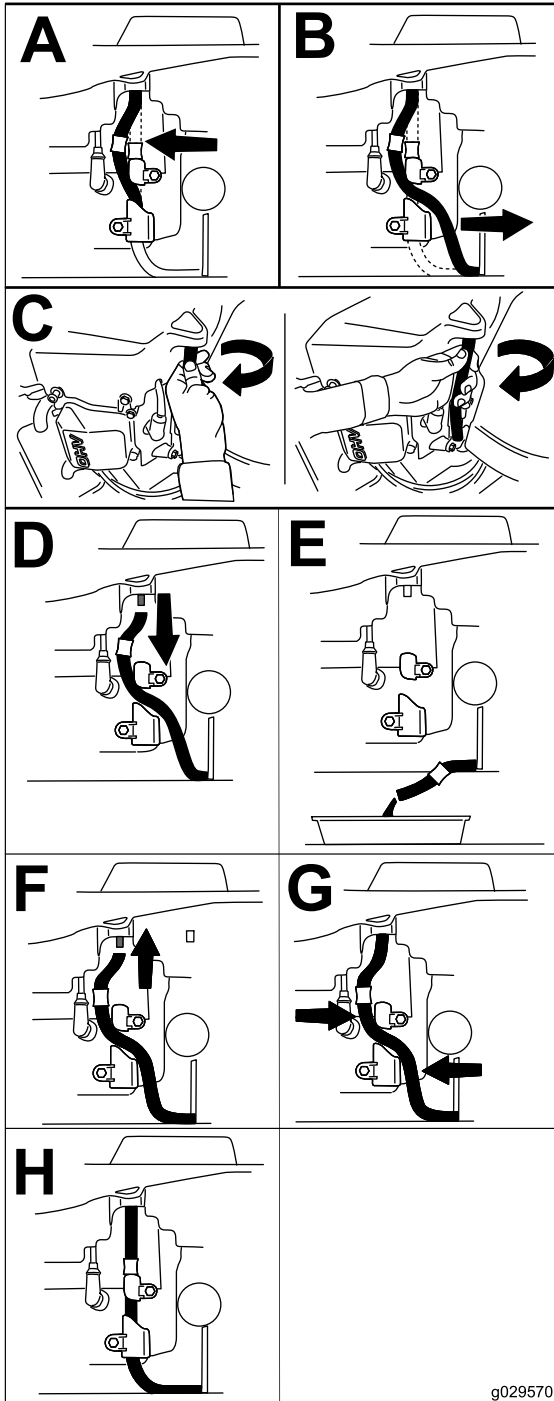

g029570

g029570

Figure 46

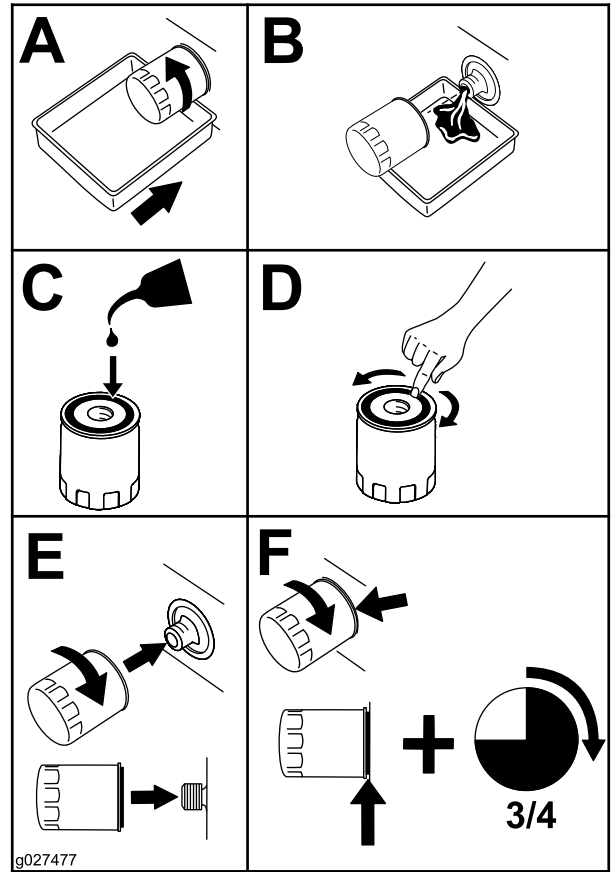

g027477

g027477

Figure 47

6. Slowly pour approximately 80% of the specified oil into the filler tube and slowly add the additional oil to bring it to the Full mark (Figure 48).

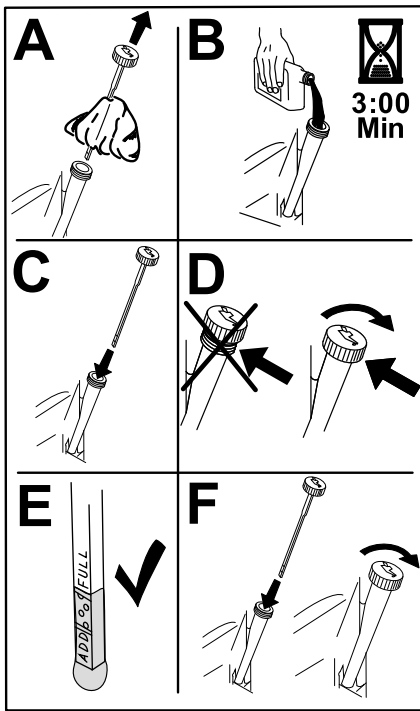

Figure 48

g235264

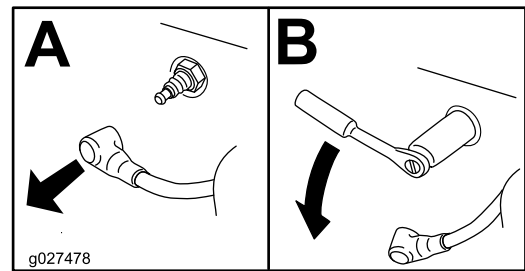

Figure 49

g027478

## Checking the Spark Plug

**Important:** Do not clean the spark plug(s). Always replace the spark plug(s) when it has a black coating, worn electrodes, an oily film, or cracks.

If you see light brown or gray on the insulator, the engine is operating properly. A black coating on the insulator usually means the air cleaner is dirty.

Set the gap to 0.75 mm (0.03 inch).

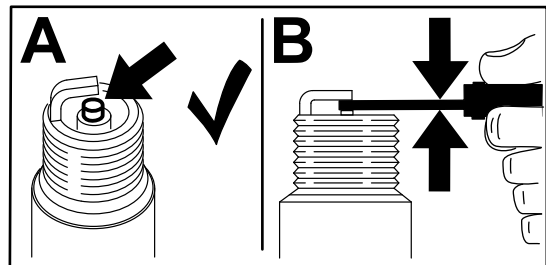

Figure 50

g206628

7. Dispose of the used oil at a recycling center.

## Servicing the Spark Plug

**Service Interval:** Every 100 hours/Yearly (whichever comes first)—Check the spark plug(s).

Every 200 hours/Every 2 years (whichever comes first)—Replace the spark plug(s).

Ensure that the air gap between the center and side electrodes is correct before installing the spark plug. Use a spark plug wrench for removing and installing the spark plug and a gapping tool or feeler gauge to check and adjust the air gap. Install a new spark plug if necessary.

**Type:** Champion® RN9YC or NGK® BPR6ES

**Air gap:** 0.76 mm (0.03 inch)

## Removing the Spark Plug

1. Park the machine on a level surface, disengage the blade-control switch (PTO), and engage the parking brake.
2. Shut off the engine, remove the key, and wait for all moving parts to stop before leaving the operating position.
3. Clean the area around the base of the plug to keep dirt and debris out of the engine.
4. Remove the spark plug (Figure 49).

## Installing the Spark Plug

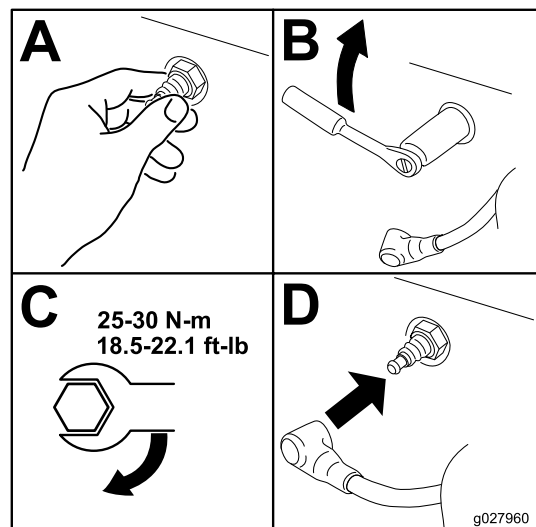

Figure 51

g027960

## Cleaning the Cooling System

1. Park the machine on a level surface, disengage the blade-control switch (PTO), and engage the parking brake.
2. Shut off the engine, remove the key, and wait for all moving parts to stop before leaving the operating position.
3. Remove the air filter from the engine.
4. Remove the engine shroud.
5. To prevent debris entering the air intake, install the air filter to the filter base.
6. Clean debris and grass from the parts.
7. Remove the air filter and install the engine shroud.
8. Install the air filter.

## Checking the Spark Arrester

### For Machines with a Spark Arrester

**Service Interval:** Every 50 hours

#### **▲ WARNING**

**Hot exhaust-system components may ignite fuel vapors even after you shut off the engine. Hot particles exhausted during engine operation may ignite flammable materials, resulting in personal injury or property damage.**

**Do not refuel or run the engine unless the spark arrestor is installed.**

1. Park the machine on a level surface, disengage the PTO, and engage the parking brake.
2. Shut off the engine, remove the key, and wait for all moving parts to stop before leaving the operating position.
3. Wait for the muffler to cool.
4. If you see any breaks in the screen or welds, replace the arrestor.
5. If the screen is plugged, remove the arrestor, shake loose particles out of the arrestor, and clean the screen with a wire brush (soak the screen in solvent if necessary).
6. Install the arrestor on the exhaust outlet.

## Replacing the Emissions-Air Intake Filter

**Service Interval:** Every 500 hours

1. Park the machine on a level surface, disengage the blade-control switch (PTO), and engage the parking brake.
2. Shut off the engine, remove the key, and wait for all moving parts to stop before leaving the operating position.
3. Remove the filter from the vent hose.
4. Insert a new filter into the end of the vent hose.

# Fuel System Maintenance

## **⚠ DANGER**

In certain conditions, fuel is extremely flammable and highly explosive. A fire or explosion from fuel can burn you, others, and can damage property.

- Perform any fuel-related maintenance when the engine is cold. Do this outdoors in an open area. Wipe up any fuel that spills.
- Never smoke when draining fuel, and stay away from an open flame or where a spark may ignite the fuel fumes.

## Replacing the Fuel Filter

**Service Interval:** Every 500 hours/Yearly (whichever comes first) (more often in dusty, dirty conditions).

**Important:** Install the fuel line hoses and secure with plastic ties the same as they were originally installed at the factory to keep the fuel line away from components that can cause fuel line damage.

The fuel filter is located near the engine on the left front of the engine.

1. Park the machine on a level surface, disengage the blade-control switch (PTO), and engage the parking brake.
2. Shut off the engine, remove the key, and wait for all moving parts to stop before leaving the operating position.
3. Allow the machine to cool down.
4. Close the fuel-shutoff valve under the seat.
5. Replace the fuel filter ([Figure 52](#)).

**Note:** Ensure that the markings on the filter follow the fuel flow direction.

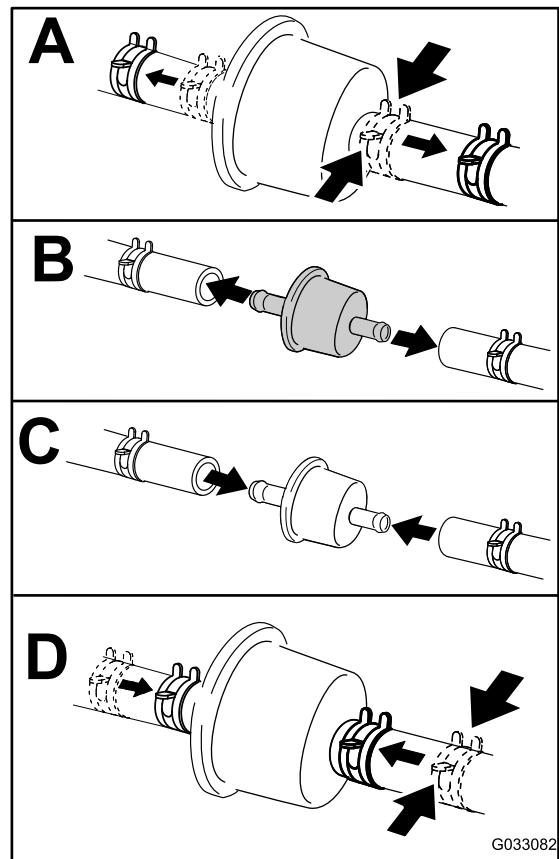

Figure 52

g033082

6. Open the fuel-shutoff valve.

## Servicing the Fuel Tank

Do not attempt to drain the fuel tank. Ensure that an Authorized Service Dealer drains the fuel tank and services any components of the fuel system.

# Electrical System Maintenance

## Electrical System Safety

- Disconnect the battery before repairing the machine. Disconnect the negative terminal first and the positive last. Connect the positive terminal first and the negative last.
- Charge the battery in an open, well-ventilated area, away from sparks and flames. Unplug the charger before connecting or disconnecting the battery. Wear protective clothing and use insulated tools.

## Servicing the Battery

Service Interval: Monthly

## Removing the Battery

### ⚠ WARNING

Battery terminals or metal tools could short against metal machine components, causing sparks. Sparks can cause the battery gasses to explode, resulting in personal injury.

- When removing or installing the battery, do not allow the battery terminals to touch any metal parts of the machine.
- Do not allow metal tools to short between the battery terminals and metal parts of the machine.

1. Park the machine on a level surface, disengage the blade-control switch (PTO), and engage the parking brake.
2. Shut off the engine, remove the key, and wait for all moving parts to stop before leaving the operating position.
3. Disconnect the negative (black) ground cable from the battery post (Figure 53).

**Note:** Retain all fasteners.

### ⚠ WARNING

Incorrectly removing the cables from battery could damage the machine and cables, causing sparks. Sparks can cause the battery gasses to explode, resulting in personal injury.

- Always disconnect the negative (black) battery cable before disconnecting the positive (red) cable.
- Always connect the positive (red) battery cable before connecting the negative (black) cable.

4. Slide the rubber cover off the positive (red) cable.
5. Disconnect the positive (red) cable from the battery post (Figure 52).

**Note:** Retain all fasteners.

6. Remove the rubber strap (Figure 53).
7. Remove the battery.

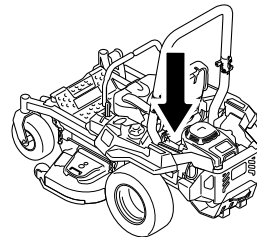

g036853

g036853

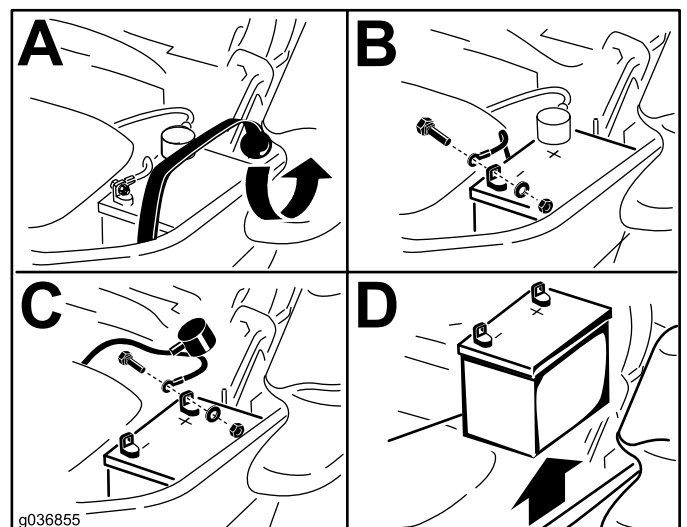

g036855

g036855

Figure 53

# Charging the Battery

## ⚠ WARNING

Charging the battery produces gasses that can explode.

Never smoke near the battery and keep sparks and flames away from the battery.

**Important:** Always keep the battery fully charged (1.265 specific gravity). This is especially important to prevent battery damage when the temperature is below 0°C (32°F).

1. Remove the battery from the chassis; refer to [Removing the Battery \(page 42\)](#).
2. Charge the battery for 10 to 15 minutes at 25 to 30 A or for 30 minutes at 10 A.

**Note:** Do not overcharge the battery.

3. When the battery is fully charged, unplug the charger from the electrical outlet, then disconnect the charger leads from the battery posts ([Figure 54](#)).
4. Install the battery in the machine and connect the battery cables; refer to [Installing the Battery \(page 43\)](#).

**Note:** Do not run the machine with the battery disconnected; electrical damage may occur.

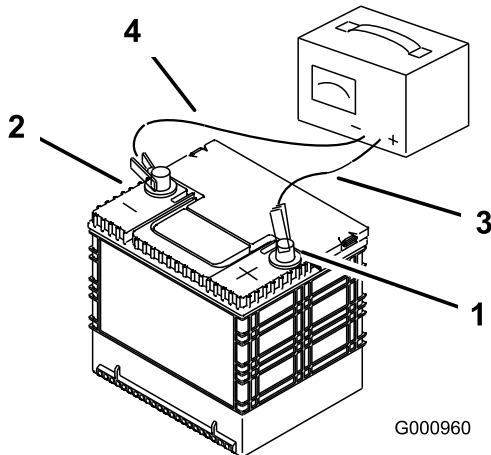

Figure 54

1. Positive (+) battery post
2. Negative (-) battery post
3. Red (+) charger lead
4. Black (-) charger lead

# Installing the Battery

1. Position the battery in the tray with the terminal posts opposite from the hydraulic tank ([Figure 53](#)).
2. Install the positive (red) battery cable to the positive (+) battery terminal.
3. Install the negative (black) battery cable and ground wire to the negative (-) battery terminal.

**Note:** For MyRide machines, ensure that the ground cable does not rub against the trailing arm or lower shock mount ([Figure 56](#)).

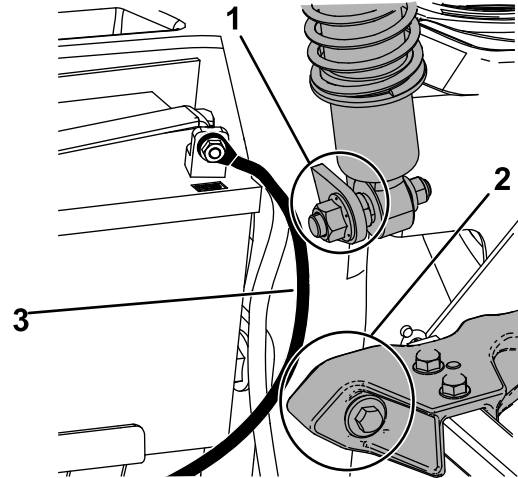

Figure 55

1. Ensure that the ground cable does not rub against the lower shock mount.
  2. Ensure that the ground cable does not rub against the trailing arm.
  3. Ground cable
- 
4. Secure the cables with 2 bolts, 2 washers, and 2 locknuts ([Figure 53](#)).
  5. Slide the red terminal boot onto the positive (+) battery terminal.
  6. Secure the battery with the rubber strap ([Figure 53](#)).

## Servicing the Fuses

The electrical system is protected by fuses. It requires no maintenance; however, if a fuse blows check the component and circuit for a malfunction or short.

The fuses are located on the right console next to the seat (Figure 56).

1. To replace the fuses, pull out the fuse to remove it.
2. Install a new fuse (Figure 56).

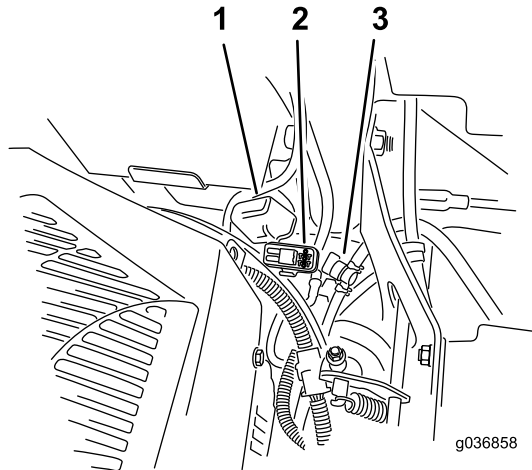

Figure 56

1. Fuse cover
2. Fuse holder
3. Fuel-shutoff valve

## Drive System Maintenance

### Checking the Seat Belt

**Service Interval:** Before each use or daily

Inspect the seat belt for wear, cuts, and proper operation of the retractor and buckle. Replace the seat belt if it is damaged.

### Checking the Roll-Bar Knobs

**Service Interval:** Before each use or daily

#### **⚠ WARNING**

To avoid injury or death from rollover, keep the roll bar in the fully raised, locked position and use the seat belt.

**Ensure that the seat is secured to the machine.**

- Check that both the mounting hardware and the knobs are in good working condition.
- Make sure that the knobs are fully engaged with the roll bar in the raised position.

**Note:** The upper hoop of the roll bar may need to be pushed forward or pulled rearward to fully engage both knobs (Figure 57 and Figure 58).

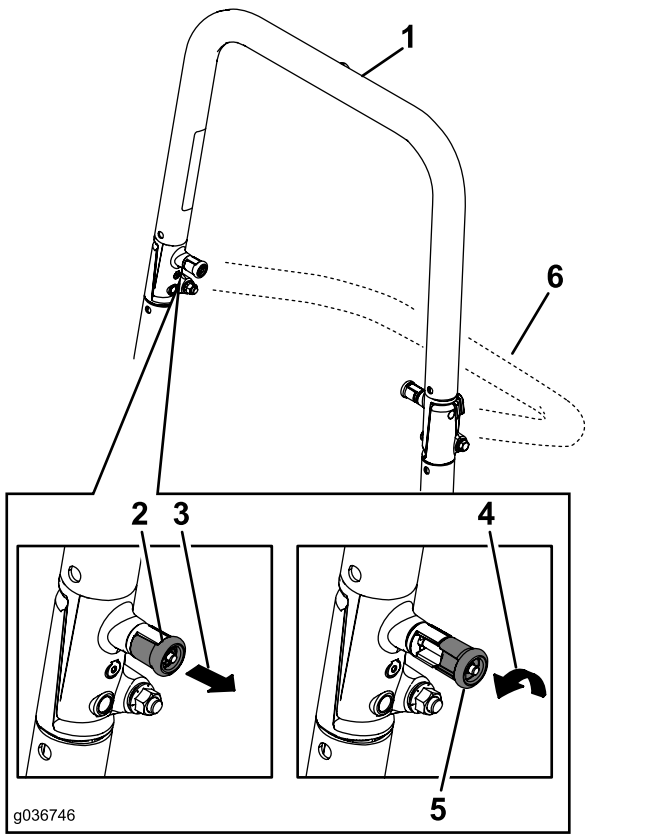

**Figure 57**

1. Roll bar in the upright position
2. Roll-bar knob in the latched position
3. Pull the roll-bar knob out and rotate it 90 degrees.
4. Rotate the roll-bar knob 90 degrees.
5. Roll-bar knob in the unlatched position
6. Roll bar in the folded position

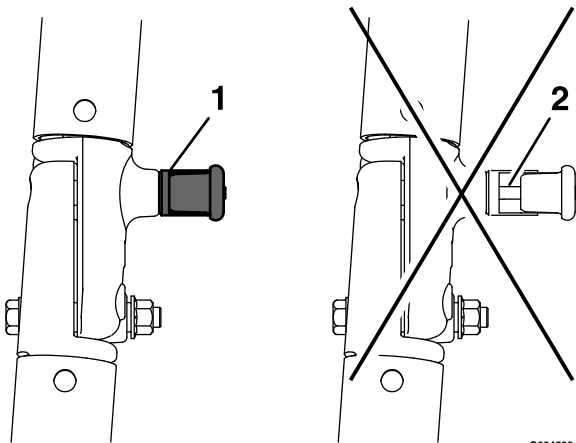
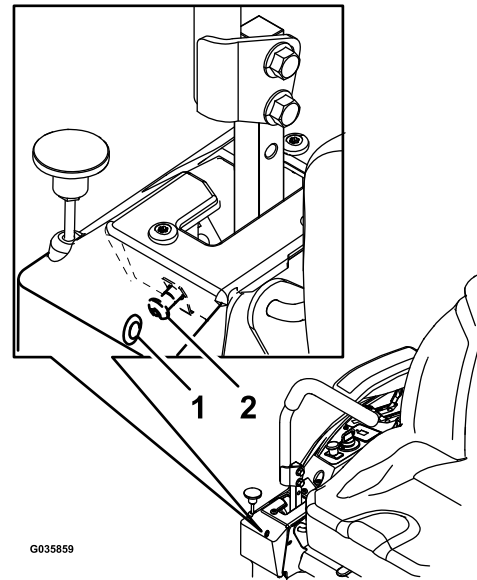

**Figure 58**

1. Engaged
2. Partially engaged—do not operate with the roll bar in this position.

## Adjusting the Tracking

1. Disengage the blade-control switch (PTO).
2. Drive to an open, flat area and move the motion-control levers to the NEUTRAL-LOCK position.
3. Move the throttle midway between the FAST and SLOW positions.
4. Move both motion-control levers forward until they both hit the stops in the T-slot.
5. Check which way the machine tracks.
6. If the machine tracks to the right, insert a 3/16 inch hex wrench through the access hole in the right front cover panel and rotate the tracking screw clockwise or counterclockwise to adjust the travel of the lever (**Figure 59**).
7. If the machine tracks to the left, insert a 3/16 inch hex wrench through the access hole in the right front cover panel and rotate the tracking screw clockwise or counterclockwise to adjust the travel of the lever (**Figure 59**).
8. Drive the machine and check the full forward tracking.
9. Repeat the adjustment until the desired tracking is obtained.



**Figure 59**

Right control lever shown

1. Access hole on front cover
2. Tracking screw panel

## Checking the Tire Pressure

**Service Interval:** Every 50 hours/Monthly (whichever comes first)

Maintain the air pressure in the front and rear tires at 90 kPa (13 psi). Uneven tire pressure can cause uneven cut. Check the tires when they are cold to get the most accurate pressure reading.

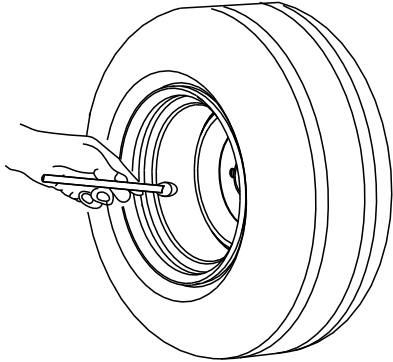

G001055

g001055

**Figure 60**

## Cooling System Maintenance

### Cleaning the Engine Screen

**Service Interval:** Before each use or daily

Before each use or daily

Before each use remove any buildup of grass, dirt, or other debris from the engine screen, engine exhaust, and the area around the engine. This helps ensure adequate cooling and correct engine speed and reduces the possibility of overheating and mechanical damage to the engine.

---

## Checking the Wheel Lug Nuts

Check and torque the wheel lug nuts to 122 to 136 N·m (90 to 100 ft-lb).

# Brake Maintenance

## Adjusting the Parking Brake

**Service Interval:** Every 500 hours

**Note:** Perform this procedure whenever you remove or replace a brake component.

1. Park the machine on a level surface, disengage the blade-control switch (PTO), and engage the parking brake.
2. Shut off the engine, remove the key, and wait for all moving parts to stop before leaving the operating position.
3. Set up the machine to be pushed by hand. Refer to [Using the Drive-Wheel Release Valves \(page 29\)](#).
4. Raise the back of the machine up and support the machine with jack stands.

### **⚠ WARNING**

**Relying solely on mechanical or hydraulic jacks to support a raised machine for service or maintenance could be dangerous because the jacks may not provide enough support or may malfunction, allowing the machine to fall and possibly cause serious injury.**

**Do not rely solely on mechanical or hydraulic jacks for support. Use adequate jack stands or equivalent support.**

5. Engage and disengage the parking brake and check each drive tire to ensure that each brake engages and disengages.
6. If an adjustment is necessary, disengage the parking brake. Remove the cotter pin from the brake linkage shaft ([Figure 61](#)).

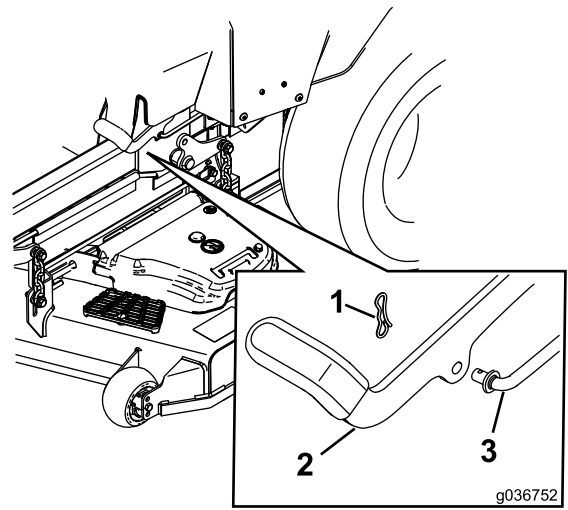

**Figure 61**

1. Cotter pin
2. Parking brake
3. Brake linkage shaft

7. Check both spring lengths as shown in [Figure 62](#). If an adjustment is necessary, turn the top nut clockwise to shorten the spring and counterclockwise to lengthen it.

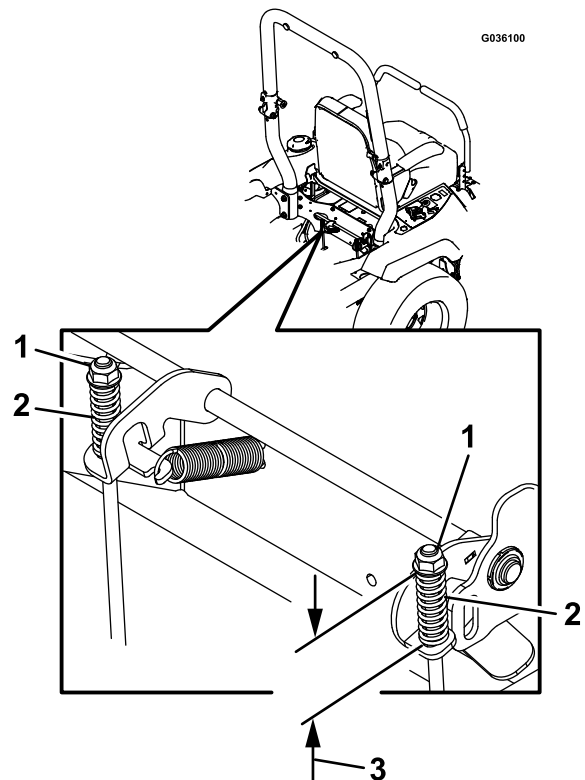

**Figure 62**

1. Top nut
2. Spring
3. 44 mm (1-3/4 inches)

8. Push the parking brake lever all the way forward and down.

9. Rotate the brake-linkage shaft until the end aligns with the hole in the lever.
  - Shorten the linkage by turning it clockwise.
  - Lengthen the linkage by turning it counterclockwise.
10. Insert the brake-linkage shaft into the parking-brake hole and secure with the cotter pin. Repeat step 5 and adjust if necessary.
11. When adjustment is complete, remove the jack stands or equivalent support and lower the machine.
12. Place the machine into the OPERATING position. Refer to [Using the Drive-Wheel Release Valves \(page 29\)](#).

## Belt Maintenance

### Inspecting the Belts

**Service Interval:** Every 50 hours

Replace the belt if it is worn. The signs of a worn belt include squealing while the belt is rotating; the blades slipping while cutting grass; and frayed edges, burn marks, and cracks on the belt.

### Replacing the Mower Belt

1. Park the machine on a level surface, disengage the blade-control switch (PTO), and engage the parking brake.
2. Shut off the engine, remove the key, and wait for all moving parts to stop before leaving the operating position.
3. Lower the mower to the 76 mm (3 inch) height of cut.
4. Loosen the bolt on each belt cover.
5. Loosen the bottom bolt holding the mower-deck curtain to the mower deck; refer to [Releasing the Mower-Deck Curtain \(page 33\)](#).
6. Remove the sheet-metal guard; refer to [Removing the Sheet-Metal Guard \(page 34\)](#).
7. Remove the belt covers and the bolts attached to them ([Figure 63](#)).

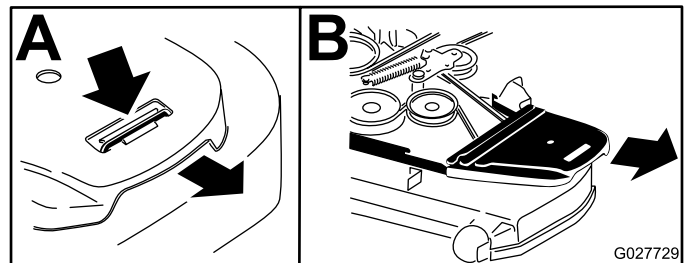

**Figure 63**

8. Remove the spring tension from the spring-loaded idler pulley. Refer to [Figure 65](#).
 

**Note:** Use the spring removal tool (Toro Part No. 92-5771) to remove the spring from the mower-deck post ([Figure 65](#)).
9. Remove the belt from the mower-deck pulleys and the clutch pulley.
10. Install the new belt around the mower pulleys and the clutch pulley under the engine ([Figure 64](#)).

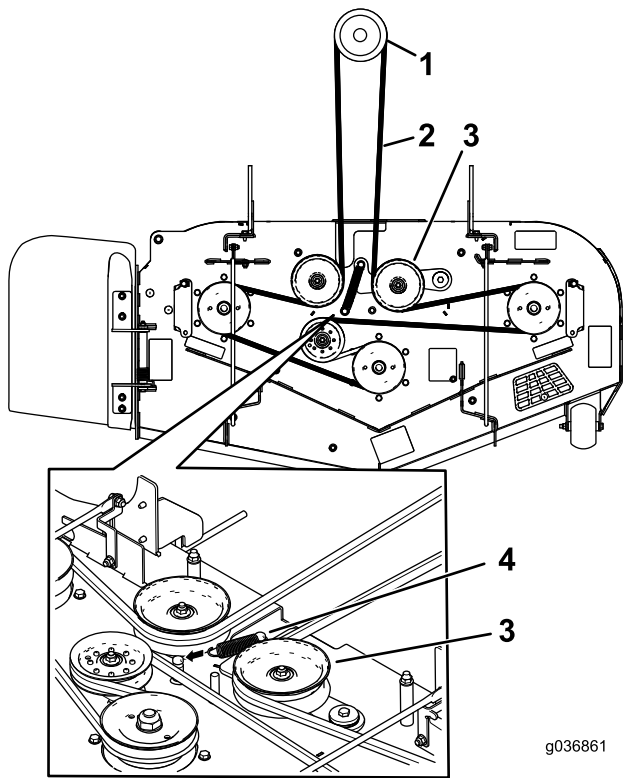

**Figure 64**

g036861

g036861

- |                  |                               |
|------------------|-------------------------------|
| 1. Clutch pulley | 3. Spring-loaded idler pulley |
| 2. Mower belt    | 4. Spring                     |

12. Install the belt covers and the bolts attached to them ([Figure 66](#)).

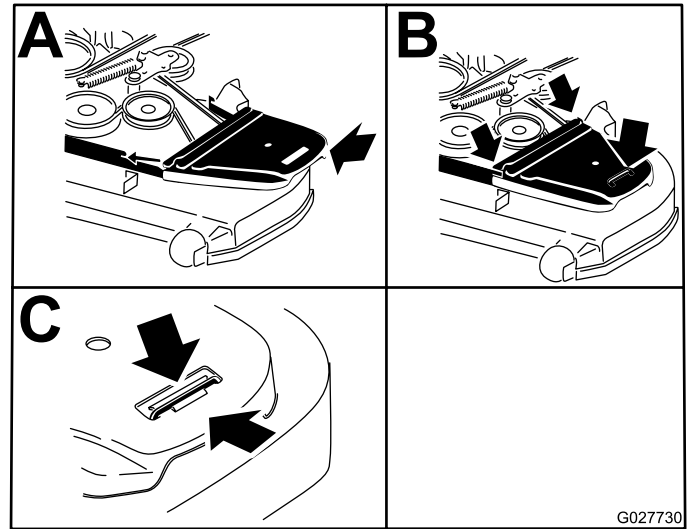

G027730

g027730

**Figure 66**

13. Install the sheet-metal guard; refer to [Removing the Sheet-Metal Guard](#) (page 34).
14. Tighten the bottom bolt holding the mower-deck curtain to the mower deck; refer to [Releasing the Mower-Deck Curtain](#) (page 33).

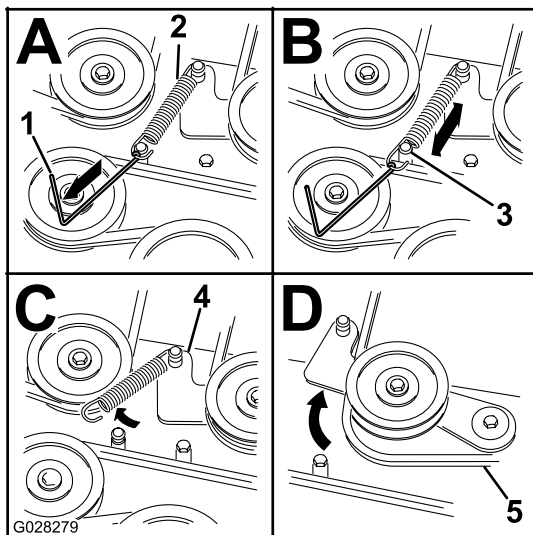

G028279

g028279

**Figure 65**

- |  |               |
|--|---------------|
| 1. Spring-removal tool (Toro Part No. 92-5771) | 4. Idler arm  |
| 2. Idler spring                                | 5. Mower belt |
| 3. Mower-deck post                             |               |

## Replacing the Hydraulic-Pump-Drive Belt

1. Park the machine on a level surface, disengage the blade-control switch (PTO), and engage the parking brake.
2. Shut off the engine, remove the key, and wait for all moving parts to stop before leaving the operating position.
3. Remove the mower belt; refer to [Replacing the Mower Belt](#) (page 48).
4. Raise the machine and support it with jack stands ([Figure 68](#)).
5. Remove the clutch stop ([Figure 67](#)).

11. Install the idler spring ([Figure 64](#)).

**Note:** Seat the spring ends in the anchor grooves.

# Controls System Maintenance

## Adjusting the Control-Handle Position

If the ends of the levers hit against each other, refer to [Adjusting the Motion-Control Linkage \(page 51\)](#).

## Adjusting the Height

You can adjust the motion control levers higher or lower for maximum comfort.

1. Disengage the blade-control switch (PTO), move the motion-control levers to the NEUTRAL-LOCK position, and engage the parking brake.
2. Shut off the engine, remove the key, and wait for all moving parts to stop before leaving the operating position.
3. Remove the hardware holding the control lever to the control-arm shaft.

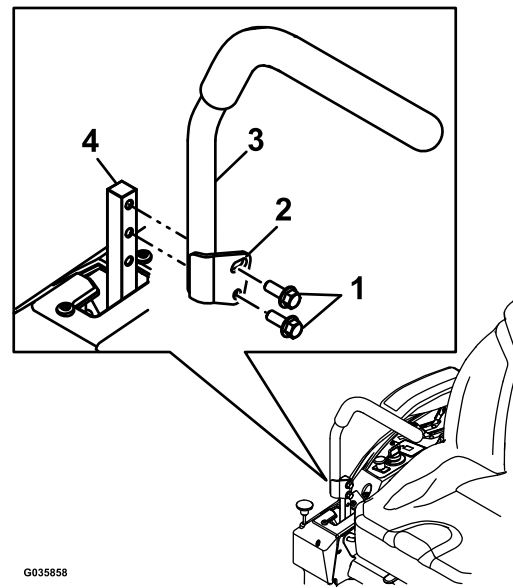

**Figure 69**

- |                 |                      |
|-----------------|----------------------|
| 1. Bolts        | 3. Control lever     |
| 2. Slotted hole | 4. Control-arm shaft |

4. Move the control lever to the next set of holes. Secure the lever with the hardware.
5. Repeat the adjustment for the opposite control lever.

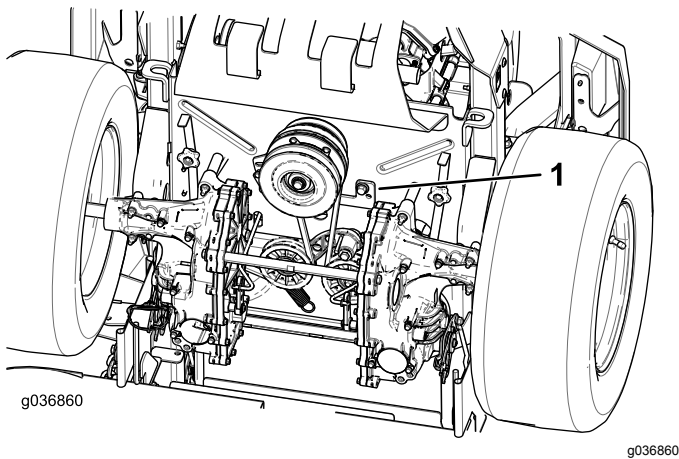

**Figure 67**

1. Clutch stop

6. Remove the idler spring from the post ([Figure 68](#)).
7. Remove the existing belt from the hydraulic-pump-drive pulleys and the engine pulley.
8. Install the new belt around the engine pulley and the 2 hydraulic-pump pulleys ([Figure 68](#)).

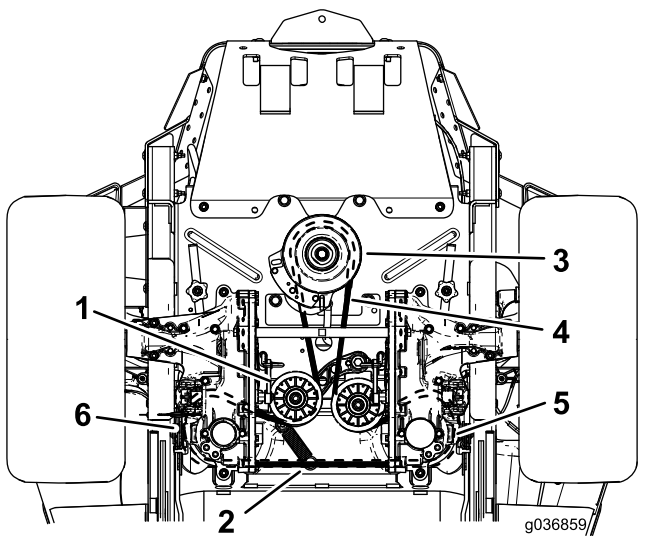

**Figure 68**

- |                      |                                |
|----------------------|--------------------------------|
| 1. Idler pulley      | 4. Pump-drive belt             |
| 2. Idler-spring post | 5. Right hydraulic-pump pulley |
| 3. Engine pulley     | 6. Left hydraulic-pump pulley  |

9. Install the clutch stop ([Figure 67](#)).
10. Install the mower belt; refer to [Belt Maintenance \(page 48\)](#).

## Adjusting the Tilt

1. Disengage the blade-control switch (PTO), move the motion-control levers to the NEUTRAL-LOCK position, and engage the parking brake.
2. Shut off the engine, remove the key, and wait for all moving parts to stop before leaving the operating position.
3. Loosen the upper bolt holding the control lever to the control arm shaft.
4. Loosen the lower bolt just enough to pivot the control lever fore or aft. Tighten both bolts to secure the control in the new position.
5. Repeat the adjustment for the opposite control lever.

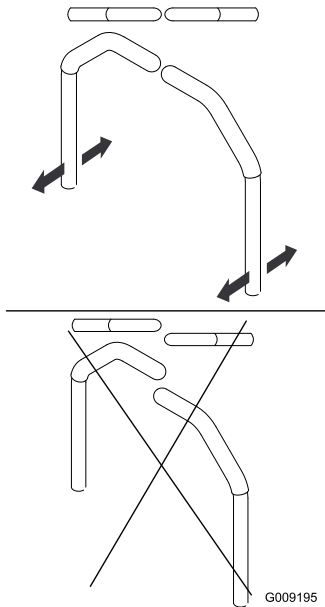

Figure 70

## Adjusting the Motion-Control Linkage

Located on either side of the machine, below the seat, are the pump-control linkages. Rotating the end nut with a 1/2-inch deep socket wrench allows fine tuning adjustments so that the machine does not move in neutral. Any adjustments should be made for neutral positioning only.

### **⚠ WARNING**

**The engine must be running and the drive wheels turning so that you can perform the adjustments. Contact with moving parts or hot surfaces may cause personal injury.**

**Keep your fingers, hands, and clothing clear of rotating components and hot surfaces.**

1. Disengage the blade-control switch (PTO), move the motion-control levers to the NEUTRAL-LOCK position, and engage the parking brake.
2. Shut off the engine, remove the key, and wait for all moving parts to stop before leaving the operating position.
3. Push the deck-lift pedal and remove the height-of-cut pin. Lower the deck to the ground.
4. Raise the rear of the machine up and support it with jack stands (or equivalent support) just high enough to allow the drive wheels to turn freely.
5. Remove the electrical connection from the seat safety switch, located under the bottom cushion of the seat.

**Note:** The switch is a part of the seat assembly.

6. **Temporarily** install a jumper wire across the terminals in the connector of the main harness.
7. Start the engine, run it at full throttle, and disengage the parking brake.
8. Run the machine at least 5 minutes with the drive levers in the full forward speed to bring the hydraulic fluid up to operating temperature.

**Note:** Before starting the engine, ensure that the parking brake is engaged and that the motion-control levers are out. You do not have to be in the seat.

9. Bring the motion-control levers into the NEUTRAL position.
10. Check and ensure that the control-plate tabs touch the return-to-neutral plates on the hydraulic units.
11. Adjust the pump-control-rod lengths by turning the nut in the appropriate direction until the wheels slightly creep in reverse (see [Figure 71](#)).
12. Move the motion-control levers to the REVERSE position and while applying slight pressure to the lever, allow the reverse indicator springs to bring the levers back to neutral.

**Note:** The wheels should stop turning or slightly creep in reverse.

**Note:** You may need to remove the motion-control cover to gain access.

# Hydraulic System Maintenance

## Hydraulic System Safety

- Seek immediate medical attention if fluid is injected into skin. Injected fluid must be surgically removed within a few hours by a doctor.
- Ensure that all hydraulic-fluid hoses and lines are in good condition and all hydraulic connections and fittings are tight before applying pressure to the hydraulic system.
- Keep your body and hands away from pinhole leaks or nozzles that eject high-pressure hydraulic fluid.
- Use cardboard or paper to find hydraulic leaks.
- Safely relieve all pressure in the hydraulic system before performing any work on the hydraulic system.

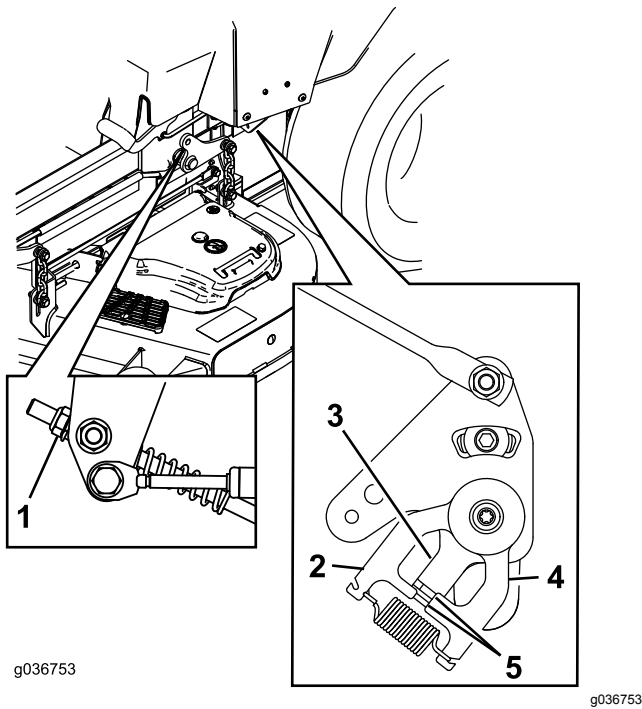

Figure 71

- |                     |  |
|---------------------|--|
| 1. Nut              | 4. Return-to-neutral plate               |
| 2. Stationary plate | 5. Tabs touching return to neutral plate |
| 3. Control plate    |  |

13. Shut off the machine.
14. Remove the jumper wire from the wire harness and plug the connector into the seat switch.
15. Remove the jack stands.
16. Raise the mower deck and install the height-of-cut pin.
17. Check and ensure that the machine does not creep in neutral with the parking brake disengaged.

## Servicing the Hydraulic System

### Hydraulic Fluid Specifications

**Hydraulic Fluid Type:** Toro® HYPR-OIL™ 500 hydraulic fluid (preferred) or Mobil 1 15W-50 oil.

**Important:** Use the fluid specified. Other fluids could cause system damage.

**Hydraulic System Capacity (with filters removed):** 4.45 L (150 fl oz)

### Checking the Hydraulic Fluid Level

**Service Interval:** Before each use or daily

1. Allow the hydraulic fluid to cool down. Check the oil level when the fluid is cold.
2. Check expansion reservoir and if necessary add Toro® HYPR-OIL™ 500 hydraulic fluid to the FULL COLD line.

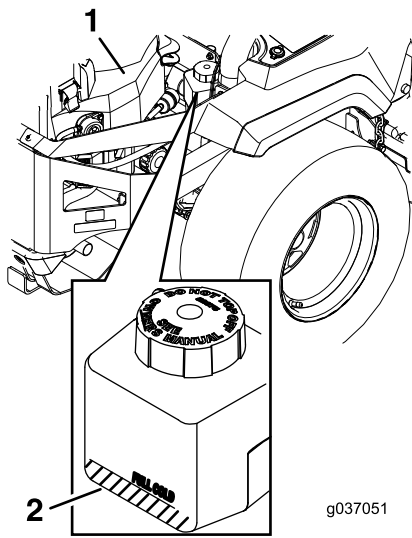

**Figure 72**

1. Engine                      2. Expansion tank

## Changing the Hydraulic-System Filters and Fluid

**Service Interval:** After the first 75 hours—Change the hydraulic-system filters and fluid.

Every 500 hours—After the initial change—change the hydraulic-system filters and fluid when using Toro® HYPR-OIL™ 500 fluid (change it more often under severe conditions).

Every 250 hours—After the initial change—change the hydraulic-system filters and fluid when using Mobil 1 15W50 fluid (change it more often under severe conditions).

Change the filters and fluid at the same time. **Do not** use the fluid again. Purge any air in the system after you install the new filters and add fluid. Refer to [Bleeding the Hydraulic System \(page 54\)](#).

Repeat the bleeding process until the fluid remains at the FULL COLD line in the reservoir after purging. **Failure to properly perform this procedure can result in irreparable damage to the transaxle drive system.**

### Removing Hydraulic-System Filters

1. Park the machine on a level surface, disengage the blade-control switch (PTO), and engage the parking brake.
2. Shut off the engine, remove the key, and wait for all moving parts to stop before leaving the operating position.
3. Allow the engine to cool.

4. Locate the filter and guards on each transaxle-drive system ([Figure 73](#)).
5. Remove the 3 screws securing the filter guard and guard ([Figure 73](#)).

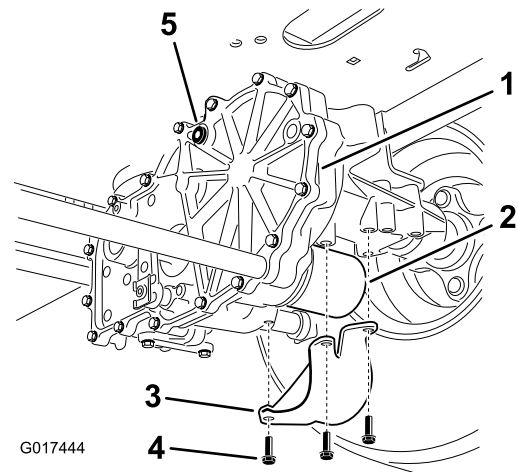

**Figure 73**

Right side shown

1. Transaxle drive                      4. Screws  
 2. Filter                                      5. Vent plug  
 3. Filter guard

6. Carefully clean the area around the filters.
- Important: Do not allow dirt to enter the hydraulic system, or contamination may occur.**
7. Place a drain pan below the filter to catch the fluid that drains when the filter and vent plugs are removed.
8. Locate and remove the vent plug on each transmission
9. Unscrew the filter to remove it, and allow the fluid to drain from the drive system.
10. Repeat this procedure for both filters.

### Installing the Hydraulic-System Filters

1. Apply a thin coat of hydraulic fluid on the surface of the rubber seal of each filter.
2. Turn the filter clockwise until the rubber seal contacts the filter adapter, then tighten the filter an additional 3/4 to 1 full turn.
3. Repeat for the opposite filter.
4. Install the filter guards over each filter that you previously removed.
5. Use the 3 screws to secure the filter guards.

6. Verify that the vent plugs are removed before adding the fluid.
7. Slowly pour the specified fluid through the expansion reservoir until fluid comes out of 1 of the vent-plug holes.
8. Install the vent plug.
9. Torque the plug to 20 N·m (15 ft·lb).
10. Continue to add fluid through the expansion reservoir until fluid comes out of the remaining vent-plug hole on the second transmission.
11. Install the opposite vent plug.
12. Torque the plug to 20 N·m (15 ft·lb).
13. Continue to add fluid through the expansion reservoir until it reaches the FULL COLD line on the expansion reservoir.
14. Proceed to [Bleeding the Hydraulic System](#) (page 54).

**Important:** Failure to perform the *Bleeding the Hydraulic System* procedure after changing hydraulic filters and fluid can result in irreparable damage to the transaxle drive system.

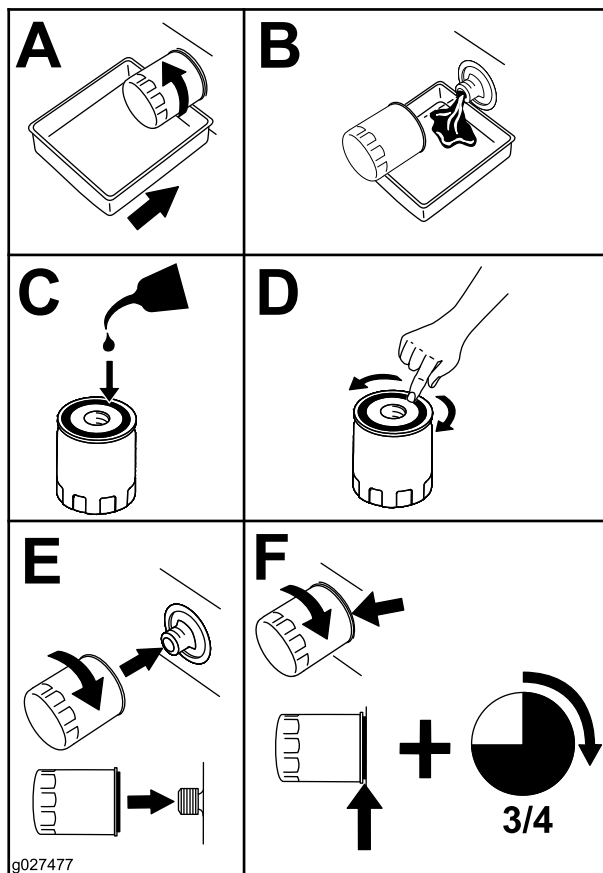

Figure 74

## Bleeding the Hydraulic System

1. Raise the rear of machine and support it with jack stands (or equivalent support) just high enough to allow the drive wheels to turn freely.

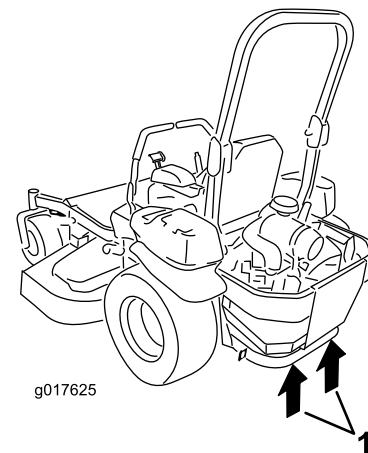

Figure 75

1. Jacking points

2. Start the engine, move the throttle control ahead to the 1/2 throttle position, and disengage the parking brake.
  - A. Move the bypass levers into the pushing the machine position. With the bypass valves open and the engine running, slowly move the motion-control levers in both forward and reverse 5 or 6 times.
  - B. Move the bypass levers into the operating the machine position.
  - C. With the bypass valve closed and the engine running, slowly move the control lever in both forward and reverse directions 5 to 6 times.
  - D. Shut off the engine and check the fluid level in the expansion reservoir. Add the specified fluid until it reaches the FULL COLD line on the expansion reservoir.
3. Repeat step 2 until all the air is completely purged from the system.

**Note:** When the transaxle operates at normal noise levels, moves smoothly forward, and reverses at normal speeds, it is purged.

4. Check the fluid level in the expansion reservoir a final time. Add the specified fluid as until it reaches the FULL COLD line on the expansion reservoir.

# Mower Deck Maintenance

## Servicing the Cutting Blades

### Blade Safety

A worn or damaged blade can break, and a piece of the blade could be thrown toward you or bystanders, resulting in serious personal injury or death. Trying to repair a damaged blade may result in discontinued safety certification of the product.

- Inspect the blades periodically for wear or damage.
- Use care when checking the blades. Wrap the blades or wear gloves, and use caution when servicing the blades. Only replace or sharpen the blades; never straighten or weld them.
- On multi-bladed machines, take care as rotating 1 blade can cause other blades to rotate.

### Before Inspecting or Servicing the Blades

1. Park the machine on a level surface, disengage the blade-control switch (PTO), and engage the parking brake.
2. Shut off the engine, remove the key, and disconnect the spark-plug wires from the spark plugs.

### Inspecting the Blades

**Service Interval:** Before each use or daily

1. Inspect the cutting edges ([Figure 76](#)).
2. If the edges are not sharp or have nicks, remove and sharpen the blade; refer to [Sharpening the Blades](#) (page 57).
3. Inspect the blades, especially in the curved area.
4. If you notice any cracks, wear, or a slot forming in this area, immediately install a new blade ([Figure 76](#)).

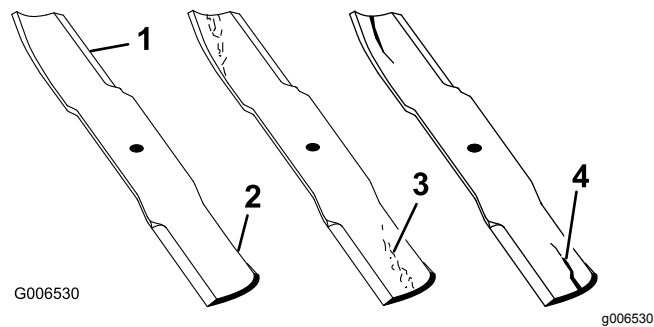

**Figure 76**

1. Cutting edge
2. Curved area
3. Wear/slot forming
4. Crack

### Checking for Bent Blades

**Note:** The machine must be on a level surface for the following procedure.

1. Raise the mower deck to the highest height-of-cut position.
2. While wearing thickly padded gloves, or other adequate hand protection, slowly rotate the blade into a position that allows you to measure the distance between the cutting edge and the level surface the machine is on ([Figure 77](#)).

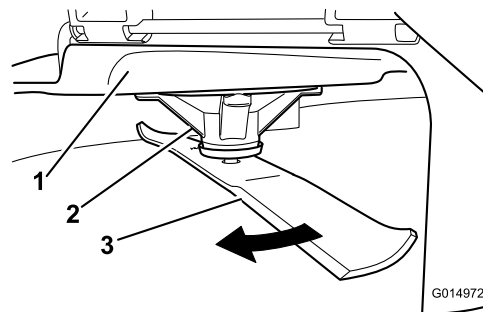

**Figure 77**

1. Deck
2. Spindle housing
3. Blade

3. Measure from the tip of the blade to the flat surface ([Figure 78](#)).

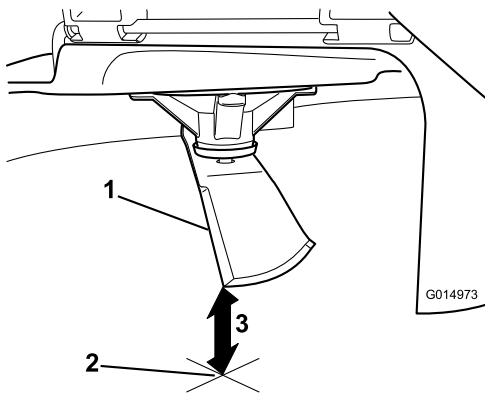

**Figure 78**

1. Blade (in position for measuring)
2. Level surface
3. Measured distance between blade and the surface (A)

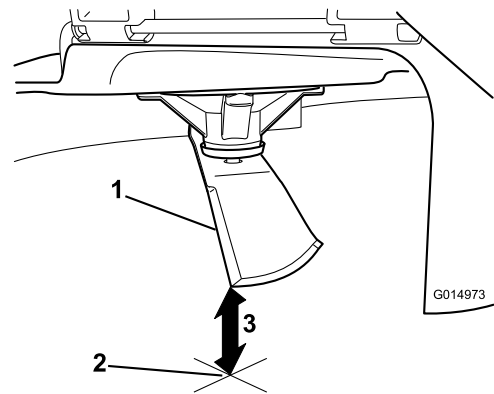

**Figure 80**

1. Opposite blade edge (in position for measuring)
2. Level surface
3. Second measured distance between blade and surface (B)

4. Rotate the same blade 180 degrees so that the opposing cutting edge is now in the same position (Figure 79).

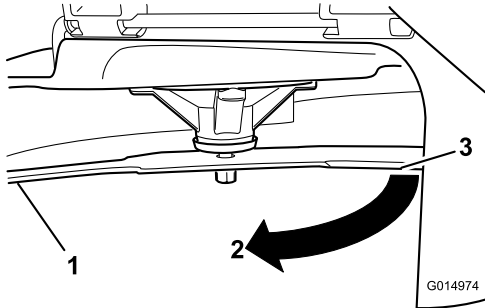

**Figure 79**

1. Blade (side previously measured)
2. Measurement (position used previously)
3. Opposing side of blade being moved into measurement position

5. Measure from the tip of the blade to the flat surface (Figure 80).

**Note:** The variance should be no more than 3 mm (1/8 inch).

- A. If the difference between A and B is greater than 3 mm (1/8 inch), replace the blade with a new blade; refer to [Removing the Blades \(page 56\)](#) and [Installing the Blades \(page 57\)](#).

**Note:** If a bent blade is replaced with a new blade, and the dimension obtained continues to exceed 3 mm (1/8 inch), the blade spindle could be bent. Contact an Authorized Service Dealer for service.

- B. If the variance is within constraints, move to the next blade.

6. Repeat this procedure on each blade.

## Removing the Blades

Replace the blades if they hit a solid object, or if the blade is out of balance or bent.

1. Hold the spindle shaft with a wrench.
2. Remove the blade bolt, curved washer, and blade from the spindle shaft (Figure 81).

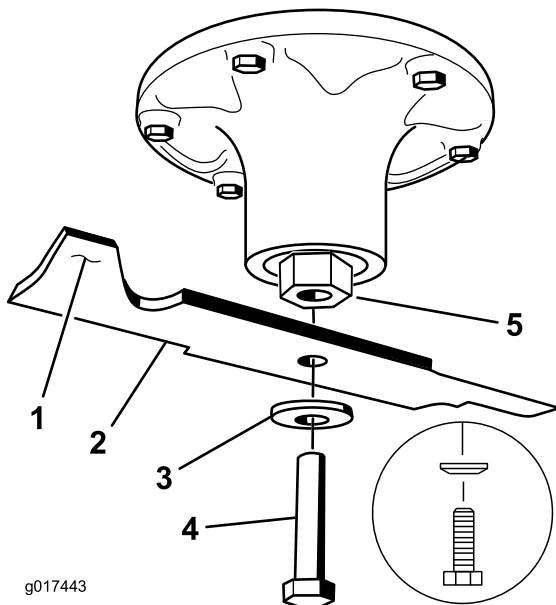

Figure 81

- |                           |                  |
|---------------------------|------------------|
| 1. Sail area of the blade | 4. Blade bolt    |
| 2. Blade                  | 5. Spindle shaft |
| 3. Curved washer          |                  |

## Sharpening the Blades

- Use a file to sharpen the cutting edge at both ends of the blade (Figure 82).

**Note:** Maintain the original angle.

**Note:** The blade retains its balance if the same amount of material is removed from both cutting edges.

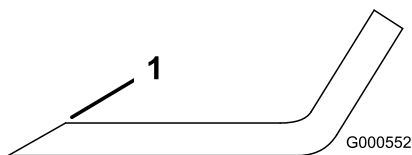
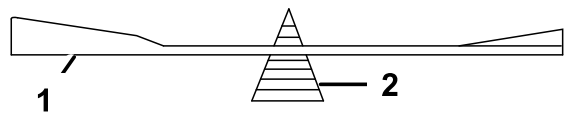

Figure 82

- Sharpen at original angle.
- Check the balance of the blade by putting it on a blade balancer (Figure 83).

**Note:** If the blade stays in a horizontal position, the blade is balanced and can be used.

**Note:** If the blade is not balanced, file some metal off the end of the sail area only (Figure 82).



G000553

g000553

Figure 83

- Blade
- Balancer

- Repeat this procedure until the blade is balanced.

## Installing the Blades

- Install the blade onto the spindle shaft (Figure 81).

**Important:** The curved part of the blade must point upward toward the inside of the mower to ensure proper cutting.

- Install the curved washer and blade bolt (Figure 81).

**Note:** Install the curved-washer cone toward the bolt head.

- Torque the blade bolt to 115 to 150 N·m (85 to 110 ft-lb).

## Leveling the Mower Deck

Check to ensure that the mower deck is level any time you install the mower or when you see an uneven cut on your lawn.

Check the mower deck for bent blades prior to leveling, and remove and replace any bent blades; refer to the [Servicing the Cutting Blades \(page 55\)](#) before continuing.

Level the mower deck side-to-side first; then you can adjust the front-to-rear slope.

### Requirements:

- The machine must be on a level surface.
- All tires must be properly inflated; refer to [Checking the Tire Pressure \(page 46\)](#).

## Adjusting the Side-to-Side Leveling and the Blade Slope

- Park the machine on a level surface, disengage the blade-control switch (PTO), and engage the parking brake.
- Shut off the engine, remove the key, and wait for all moving parts to stop before leaving the operating position.
- Check the tire pressure in the drive tires. Refer to [Checking the Tire Pressure \(page 46\)](#).

4. Position the mower deck in the transport-lock position.
5. Carefully rotate the blades from side to side.
6. Measure between the blade tip and the flat surface (Figure 84). If the measurements are not within 5 mm (3/16 inch), adjust the leveling; continue with this procedure.

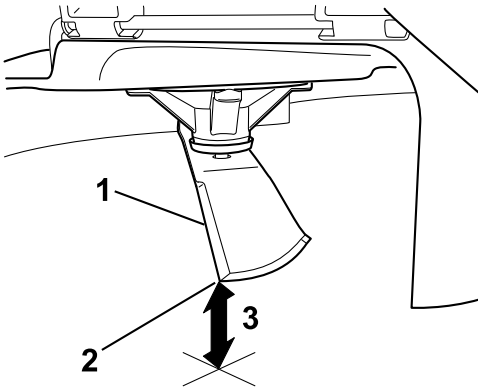
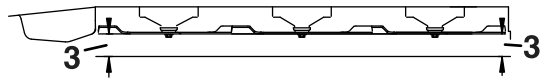
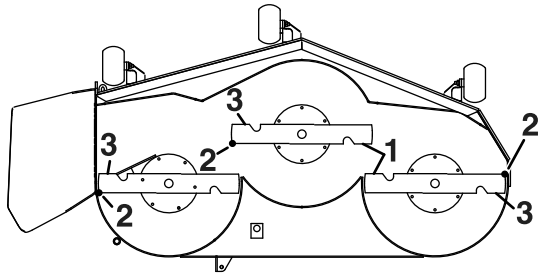

**Figure 84**

1. Blades side to side
2. Blade tip
3. Measure from the tip of the blade to the flat surface here.

7. Check the front-to-rear blade level (Figure 85). Ensure the front blade tip is lower than the rear blade tip as shown in the block height and rake table. If it needs adjustment, continue with this procedure.

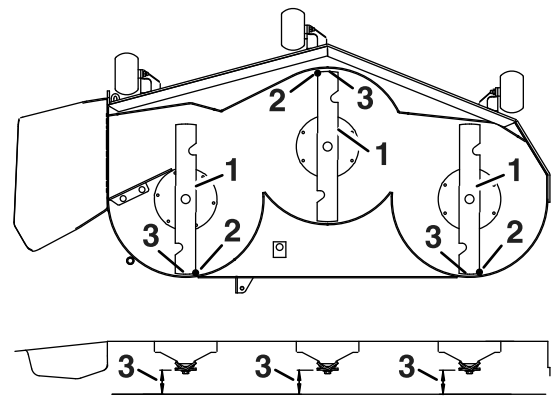

**Figure 85**

1. Blades front to rear
2. Blade tip
3. Measure from the tip of the blade to the flat surface here.

8. Set the anti-scalp rollers to top holes or remove them completely for this adjustment.
9. Place 2 blocks (see table below) under the rear edge of the cutting deck skirt; 1 on each side of the cutting deck (Figure 86).
10. Set the height-of-cut lever to the 3 inch (76 mm) position.
11. Place 2 blocks under each side of the front edge of the deck, but not under the anti-scalp roller brackets or welds.

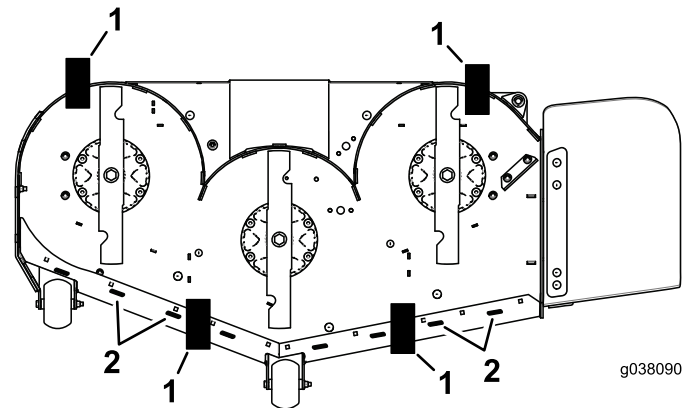

**Figure 86**  
Bottom view

1. Block—7.3 cm (2.87 inches)
2. Welds

### Block Height and Rake Table

Deck Size	Block Height	Rake
All mower decks	7.3 cm (2.87 inches)	4.8 to 6.4 mm (3/16 to 1/4 inch)

12. Carefully rotate the blades side to side (Figure 84).

13. Loosen the locknuts ([Figure 87](#)) on all 4 corners and ensure that the mower deck is sitting securely on all 4 blocks.
14. Remove any slack from the deck hangers and make sure the deck-lift foot lever is pushed back against the stop.
15. Tighten the 4 locknuts.

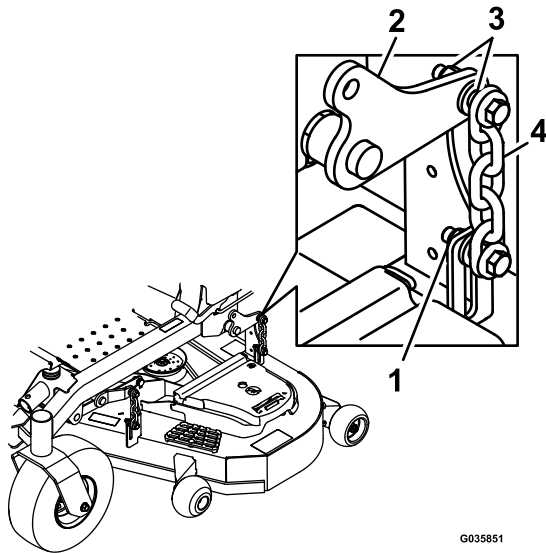

**Figure 87**

- |                  |                |
|------------------|----------------|
| 1. Locknuts      | 3. Deck hanger |
| 2. Deck-lift arm | 4. Chain       |

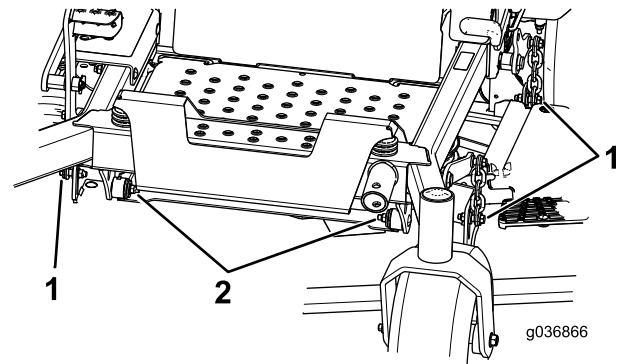

**Figure 88**

1. Remove the nuts and bolts here.
2. Remove the nuts and bolts here.

8. Slide the deck out to the right side of the machine.

## Replacing the Grass Deflector

### **⚠ WARNING**

An uncovered discharge opening could allow the machine to throw objects toward you or bystanders, resulting in serious injury. Also, contact with the blade could occur.

**Never operate the machine unless you install a mulch plate, discharge deflector, or grass collection system.**

1. Remove the locknut, bolt, spring, and spacer holding the deflector to the pivot brackets ([Figure 89](#)).
2. Remove the damaged or worn grass deflector ([Figure 89](#)).

## Removing the Mower Deck

1. Shut off the engine, wait for all moving parts to stop, and remove the key. Engage the parking brake.
2. Remove the height adjustment pin and lower the deck to the ground.
3. Place the height-adjustment pin in the 7.6 cm (3 inch) cutting-height location.
4. Remove the belt covers.
5. Loosen the mower deck idler and remove the mower belt; refer to [Belt Maintenance \(page 48\)](#).
6. Remove the bolts and nuts from the front of the plate under the footrest.
7. Remove and retain the bolts and nuts on both sides of the machine ([Figure 88](#)).

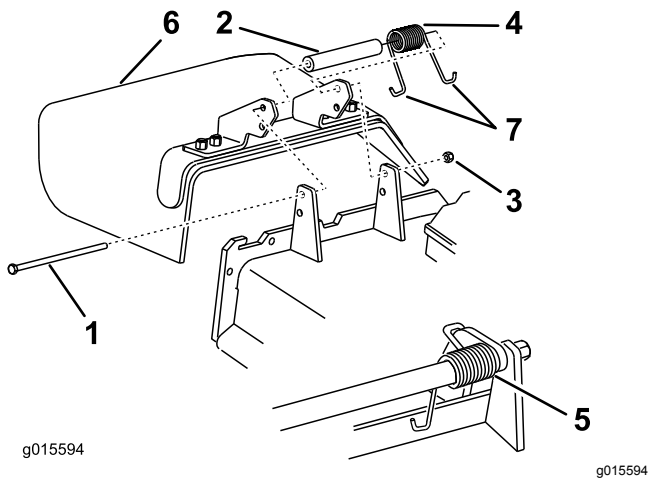

**Figure 89**

- |            |                         |
|------------|-------------------------|
| 1. Bolt    | 5. Spring installed     |
| 2. Spacer  | 6. Grass deflector      |
| 3. Locknut | 7. J-hook end of spring |
| 4. Spring  |                         |

3. Place the spacer and the spring onto grass deflector.
4. Place 1 J-hook end of the spring behind the deck edge.

**Note:** Make sure that 1 J-hook end of the spring is installed behind the deck edge before installing the bolt as shown in [Figure 89](#).

5. Install the bolt and the nut.
6. Place 1 J-hook end of the spring around the grass deflector ([Figure 89](#)).

**Important:** The grass deflector must be able to rotate. Lift the deflector up to the full open position and ensure that it rotates into the full down position.

## Cleaning

### Cleaning under the Mower Deck

**Service Interval:** Before each use or daily

1. Park the machine on a level surface, disengage the blade-control switch (PTO), and engage the parking brake.
2. Shut off the engine, remove the key, and wait for all moving parts to stop before leaving the operating position.
3. Raise the mower deck to the TRANSPORT position.

### Cleaning the Suspension System

**Service Interval:** Before each use or daily

Use compressed air to clean the suspension system.

**Note:** Do not clean the shock assemblies with pressurized water ([Figure 90](#)).

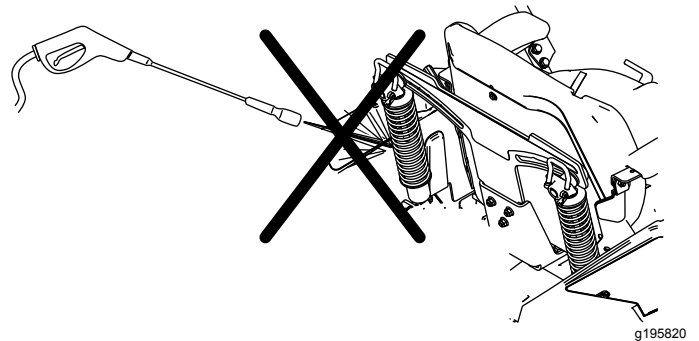

**Figure 90**

### Disposing of Waste

Engine oil, batteries, hydraulic fluid, and engine coolant are pollutants to the environment. Dispose of these according to your state and local regulations.

# Storage

## Storage Safety

- Shut off the engine, remove the key, wait for all moving parts to stop, and allow the machine to cool before storing it.
- Do not store the machine or fuel near flames or drain the fuel indoors.
- Remove the key and store it in a safe place out of the reach of children.

## Cleaning and Storage

1. Disengage the blade-control switch (PTO), and engage the parking brake.
2. Shut off the engine, remove the key, and wait for all moving parts to stop before leaving the operating position.
3. Remove grass clippings, dirt, and grime from the external parts of the entire machine, especially the engine and hydraulic system. Clean dirt and chaff from the outside of the engine cylinder head fins and blower housing.

**Important:** You can wash the machine with mild detergent and water. Do not pressure wash the machine. Avoid excessive use of water, especially near the control panel, engine, hydraulic pumps, and motors.

4. Check the parking brake operation; refer to [Adjusting the Parking Brake \(page 47\)](#).
5. Service the air cleaner; refer to [Servicing the Air Cleaner \(page 35\)](#).
6. Grease the machine; refer to [Lubrication \(page 34\)](#).
7. Change the crankcase oil; refer to [Servicing the Engine Oil \(page 37\)](#).
8. Check the tire pressure; refer to [Checking the Tire Pressure \(page 46\)](#).
9. Change the hydraulic filters; refer to [Changing the Hydraulic-System Filters and Fluid \(page 53\)](#).
10. Charge the battery; refer to [Servicing the Battery \(page 42\)](#).
11. Scrape any heavy buildup of grass and dirt from the underside of the mower, then wash the mower with a garden hose.

**Note:** Run the machine with the blade-control switch (PTO) engaged and the engine at high idle for 2 to 5 minutes after washing.

12. Check the condition of the blades; refer to [Servicing the Cutting Blades \(page 55\)](#).
  13. Prepare the machine for storage when non-use occurs over 30 days. Prepare the machine for storage as follows:
    - A. Add a petroleum-based stabilizer/conditioner to fuel in the tank. Follow mixing instructions from the stabilizer manufacturer. Do not use an alcohol-based stabilizer (ethanol or methanol).
- Note:** A fuel stabilizer/conditioner is most effective when mixed with fresh fuel and used at all times.
- B. Run the engine to distribute conditioned fuel through the fuel system for 5 minutes.
  - C. Shut off the engine, allow it to cool, and drain the fuel tank.
  - D. Start the engine and run it until it stops.
  - E. Dispose of fuel properly. Recycle the fuel according to local codes.

**Important:** Do not store fuel containing stabilizer/conditioner longer than the duration recommended by the fuel-stabilizer manufacturer.

14. Remove and check the condition of the spark plug(s); refer to [Servicing the Spark Plug \(page 39\)](#). With the spark plug(s) removed from the engine, pour 30 ml (2 tablespoons) of engine oil into the spark plug hole. Use the starter to crank the engine and distribute the oil inside the cylinder. Install the spark plug(s). Do not install the wire on the spark plug(s).
15. Check and tighten all bolts, nuts, and screws. Repair or replace any part that is damaged.
16. Paint all scratched or bare metal surfaces. Paint is available from your Authorized Service Dealer.
17. Store the machine in a clean, dry garage or storage area. Remove the key from the switch and keep it out of reach of children or other unauthorized users. Cover the machine to protect it and keep it clean.

# Troubleshooting

Problem	Possible Cause	Corrective Action
The engine overheats.	<ol style="list-style-type: none"> <li>1. The engine load is excessive.</li> <li>2. The oil level in the crankcase is low.</li> <li>3. The cooling fins and air passages under the engine-blower housing are plugged.</li> <li>4. The air cleaner is dirty.</li> <li>5. Dirt, water, or stale fuel is in the fuel system.</li> </ol>	<ol style="list-style-type: none"> <li>1. Reduce the ground speed.</li> <li>2. Add oil to the crankcase.</li> <li>3. Remove the obstruction from the cooling fins and air passages.</li> <li>4. Clean or replace the air-cleaner element.</li> <li>5. Contact an Authorized Service Dealer</li> </ol>
The starter does not crank.	<ol style="list-style-type: none"> <li>1. The blade-control switch is engaged.</li> <li>2. The motion-control levers are not in the NEUTRAL-LOCK position.</li> <li>3. The battery is dead.</li> <li>4. The electrical connections are corroded or loose.</li> <li>5. A fuse is blown.</li> <li>6. A relay or switch is damaged.</li> </ol>	<ol style="list-style-type: none"> <li>1. Disengage the blade-control switch.</li> <li>2. Move the motion-control levers outward to the NEUTRAL-LOCK position.</li> <li>3. Charge the battery.</li> <li>4. Check the electrical connections for good contact.</li> <li>5. Replace the fuse.</li> <li>6. Contact an Authorized Service Dealer.</li> </ol>
The engine does not start, starts hard, or fails to keep running.	<ol style="list-style-type: none"> <li>1. The fuel tank is empty.</li> <li>2. The fuel-shutoff valve is closed.</li> <li>3. The oil level in the crankcase is low.</li> <li>4. The throttle is not in the correct position.</li> <li>5. There is dirt in the fuel filter.</li> <li>6. Dirt, water, or stale fuel is in fuel system.</li> <li>7. The air cleaner is dirty.</li> <li>8. The seat switch is not functioning properly.</li> <li>9. The electrical connections are corroded, loose, or damaged.</li> <li>10. The relay or switch is worn or damaged.</li> <li>11. The spark plug is fouled or improperly gapped.</li> <li>12. The spark-plug wire is not connected.</li> </ol>	<ol style="list-style-type: none"> <li>1. Fill the fuel tank.</li> <li>2. Open the fuel-shutoff valve.</li> <li>3. Add oil to the crankcase.</li> <li>4. Be sure that the throttle control is midway between the slow and fast positions.</li> <li>5. Replace the fuel filter.</li> <li>6. Contact an Authorized Service Dealer.</li> <li>7. Clean or replace the air-cleaner element.</li> <li>8. Check the seat-switch indicator. Replace the seat if necessary.</li> <li>9. Check the electrical connections for good contact. Clean the connector terminals thoroughly with electrical-contact cleaner, apply dielectric grease, and make the appropriate connections.</li> <li>10. Contact an Authorized Service Dealer.</li> <li>11. Adjust or replace the spark plug.</li> <li>12. Check the spark-plug wire connection.</li> </ol>
The engine loses power.	<ol style="list-style-type: none"> <li>1. The engine load is excessive.</li> <li>2. The air cleaner is dirty.</li> <li>3. The oil level in the crankcase is low.</li> <li>4. The cooling fins and the air passages above the engine are plugged.</li> <li>5. The vent hole in the fuel cap is plugged.</li> <li>6. There is dirt in the fuel filter.</li> <li>7. There is dirt, water, or stale fuel in the fuel system.</li> </ol>	<ol style="list-style-type: none"> <li>1. Reduce the ground speed.</li> <li>2. Clean the air-cleaner element.</li> <li>3. Add oil to the crankcase.</li> <li>4. Remove the obstruction from the cooling fins and the air passages.</li> <li>5. Clean or replace the fuel cap.</li> <li>6. Replace the fuel filter.</li> <li>7. Contact an Authorized Service Dealer.</li> </ol>
The mower pulls to the left or right (with levers fully forward)	<ol style="list-style-type: none"> <li>1. The tracking needs adjustment</li> <li>2. The tire pressure in the drive tires is not correct.</li> </ol>	<ol style="list-style-type: none"> <li>1. Adjust the tracking.</li> <li>2. Adjust the tire pressure in the drive tires.</li> </ol>

Problem	Possible Cause	Corrective Action
The machine does not drive.	<ol style="list-style-type: none"> <li>1. The bypass valves are not closed tight.</li> <li>2. The pump belt is worn, loose, or broken.</li> <li>3. The pump belt is off a pulley.</li> <li>4. The idler spring is broken or missing.</li> <li>5. The hydraulic fluid level is low or too hot.</li> </ol>	<ol style="list-style-type: none"> <li>1. Tighten the bypass valves.</li> <li>2. Change the belt.</li> <li>3. Change the belt.</li> <li>4. Replace the spring.</li> <li>5. Add hydraulic fluid to the reservoirs or let it cool down.</li> </ol>
The machine vibrates abnormally.	<ol style="list-style-type: none"> <li>1. The cutting blade(s) is/are bent or unbalanced.</li> <li>2. The blade mounting bolt is loose.</li> <li>3. The engine mounting bolts are loose.</li> <li>4. The engine pulley, idler pulley, or blade pulley is loose.</li> <li>5. The engine pulley is damaged.</li> <li>6. The blade spindle is bent.</li> <li>7. The motor mount is loose or worn.</li> </ol>	<ol style="list-style-type: none"> <li>1. Install new cutting blade(s).</li> <li>2. Tighten the blade mounting bolt.</li> <li>3. Tighten the engine mounting bolts.</li> <li>4. Tighten the appropriate pulley.</li> <li>5. Contact an Authorized Service Dealer.</li> <li>6. Contact an Authorized Service Dealer.</li> <li>7. Contact an Authorized Service Dealer.</li> </ol>
The cutting height is uneven.	<ol style="list-style-type: none"> <li>1. The blade(s) is not sharp.</li> <li>2. A cutting blade(s) is/are bent.</li> <li>3. The mower is not level.</li> <li>4. An anti-scalp roller (if applicable) is not set correctly.</li> <li>5. The underside of the mower deck is dirty.</li> <li>6. The tire pressure is incorrect.</li> <li>7. A blade spindle is bent.</li> </ol>	<ol style="list-style-type: none"> <li>1. Sharpen the blade(s).</li> <li>2. Install a new cutting blade(s).</li> <li>3. Level the mower from side-to-side and front-to-rear.</li> <li>4. Adjust the anti-scalp wheel height.</li> <li>5. Clean the underside of the mower deck.</li> <li>6. Adjust the tire pressure.</li> <li>7. Contact an Authorized Service Dealer.</li> </ol>
The blades do not rotate.	<ol style="list-style-type: none"> <li>1. The drive belt is worn, loose or broken.</li> <li>2. The drive belt is off of the pulley.</li> <li>3. The power takeoff (PTO) switch or PTO clutch is faulty.</li> <li>4. The mower belt is worn, loose, or broken.</li> </ol>	<ol style="list-style-type: none"> <li>1. Install a new drive belt.</li> <li>2. Install the drive belt and check the adjusting shafts and belt guides for the correct position.</li> <li>3. Contact an Authorized Service Dealer.</li> <li>4. Install a new mower belt.</li> </ol>
The clutch does not engage.	<ol style="list-style-type: none"> <li>1. The fuse is blown.</li> <li>2. There is low voltage supply at the clutch.</li> <li>3. The coil is damaged.</li> <li>4. There is inadequate current supply.</li> <li>5. The rotor/armature air gap is too large.</li> </ol>	<ol style="list-style-type: none"> <li>1. Replace the fuse. Check the coil resistance, battery charge, charging system, and wiring connections, and replace components if necessary.</li> <li>2. Check the coil resistance, battery charge, charging system, and wiring connections and replace parts if necessary.</li> <li>3. Replace the clutch.</li> <li>4. Repair or replace the clutch lead wire or electrical system. Clean the connector contacts.</li> <li>5. Remove the shim or replace the clutch.</li> </ol>

# Schematics

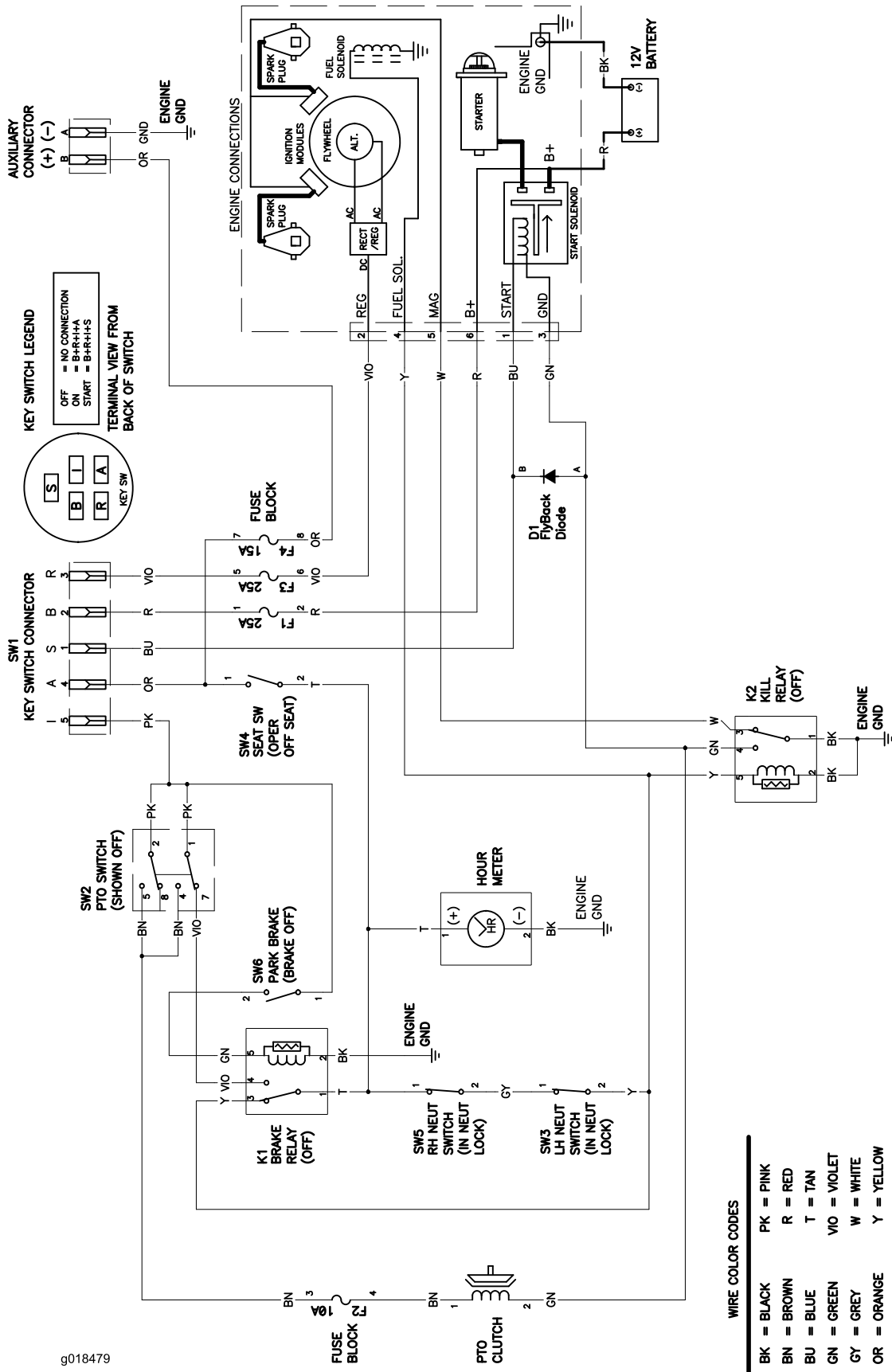

g018479

Wire Diagram—Toro Engines (Rev. A)

g018479

**Notes:**

**Notes:**

**Notes:**

## **European Privacy Notice**

### **The Information Toro Collects**

Toro Warranty Company (Toro) respects your privacy. In order to process your warranty claim and contact you in the event of a product recall, we ask you to share certain personal information with us, either directly or through your local Toro company or dealer.

The Toro warranty system is hosted on servers located within the United States where privacy law may not provide the same protection as applies in your country.

**BY SHARING YOUR PERSONAL INFORMATION WITH US, YOU ARE CONSENTING TO THE PROCESSING OF YOUR PERSONAL INFORMATION AS DESCRIBED IN THIS PRIVACY NOTICE.**

### **The Way Toro Uses Information**

Toro may use your personal information to process warranty claims, to contact you in the event of a product recall and for any other purpose which we tell you about. Toro may share your information with Toro's affiliates, dealers or other business partners in connection with any of these activities. We will not sell your personal information to any other company. We reserve the right to disclose personal information in order to comply with applicable laws and with requests by the appropriate authorities, to operate our systems properly or for our own protection or that of other users.

### **Retention of your Personal Information**

We will keep your personal information as long as we need it for the purposes for which it was originally collected or for other legitimate purposes (such as regulatory compliance), or as required by applicable law.

### **Toro's Commitment to Security of Your Personal Information**

We take reasonable precautions in order to protect the security of your personal information. We also take steps to maintain the accuracy and current status of personal information.

### **Access and Correction of your Personal Information**

If you would like to review or correct your personal information, please contact us by email at [legal@toro.com](mailto:legal@toro.com).

## **Australian Consumer Law**

Australian customers will find details relating to the Australian Consumer Law either inside the box or at your local Toro Dealer.