

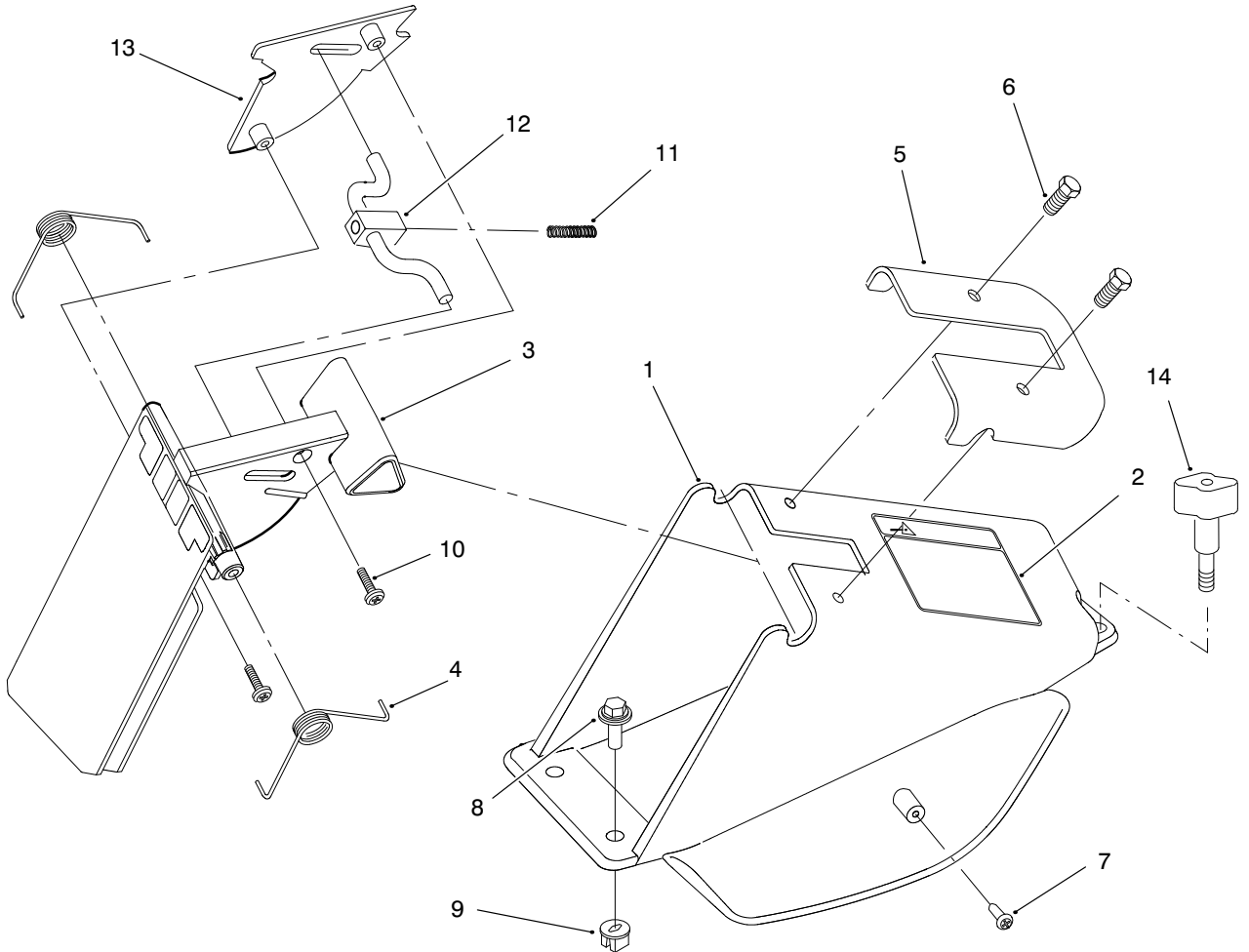

MODEL NO. 59299-9900001 & UP

PARTS  
CATALOG

21" BAG KIT



**DISCHARGE ASSEMBLY**

Ref. No.	Part No.	Description	No. Used
1	94-1683	Chute-Discharge (Incl. Ref #2)	1
2	88-3360	Decal-Caution	1
3	93-0264	Door-Discharge	1
4	88-1090	Door-Spring	2
5	93-0267	Plate-Discharge	1
6	46-8090	Screw-Plastite	2
7	32144-111	Screw-Plask	1

Ref. No.	Part No.	Description	No. Used
8	46-6811	Screw/Washer	4
9	93-0242	Grommet	4
10	32144-32	Screw	2
11	33-0450	Spring-Latch, Comp	1
12	88-1800	Latch-Door	1
13	33-0441	Cover-Door	1
14	100-1590	Knob	1

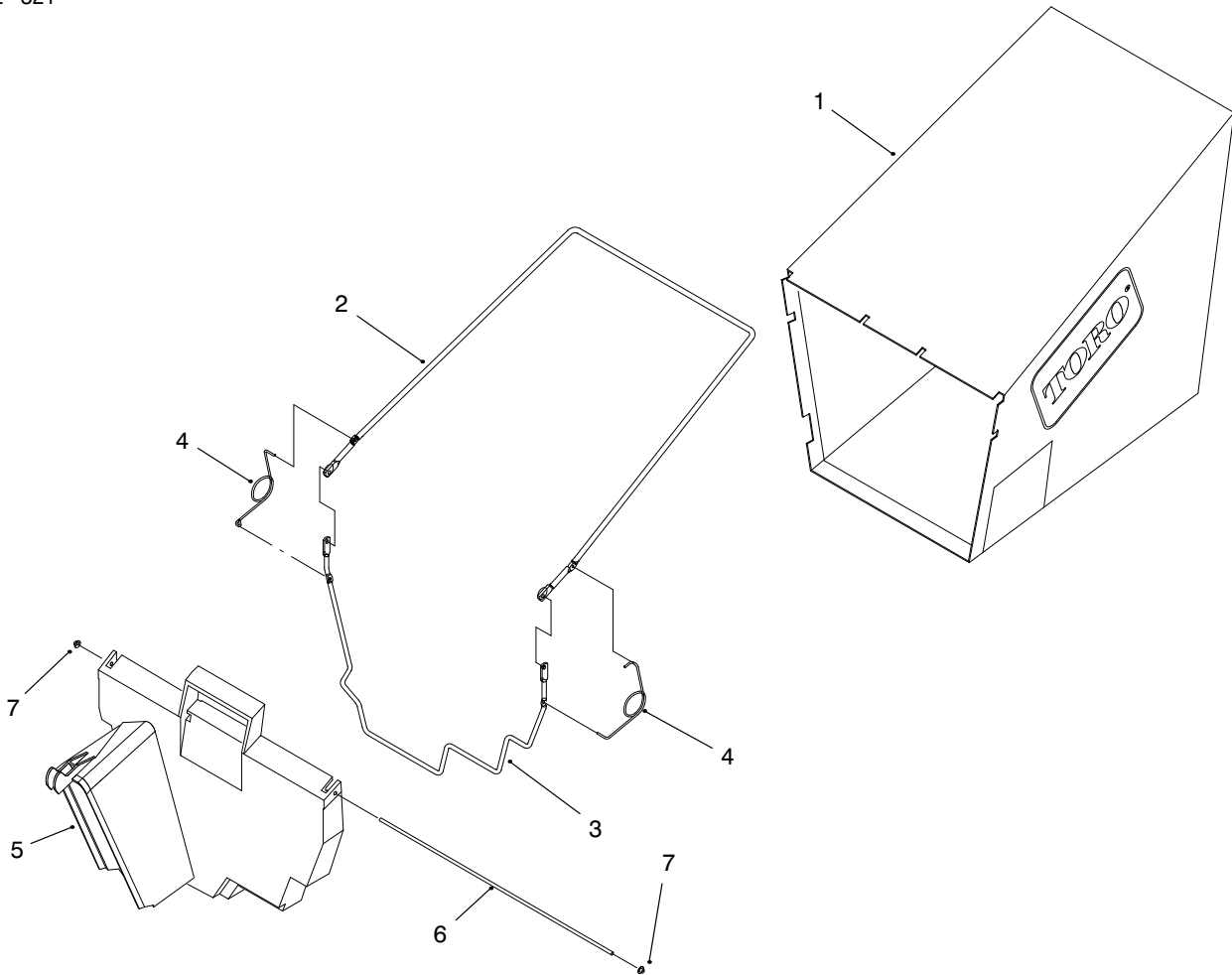

### BAG ASSEMBLY

Ref. No.	Part No.	Description	No. Used
1	93-0284	Bag-Grass	1
2	93-0281	Frame-Upper Bag	1
3	93-0282	Frame-Lower Bag	1
4	36-6910	Spring	2

Ref. No.	Part No.	Description	No. Used
5	93-0266	Door	1
6	93-283	Hinge	1
7	3290-422	Nut-Push	2