

TORO

Count on it.

OSMAC[®] G3 Satellite Installation Instructions

Introduction

The OSMAC G3 controller is designed for installation on a substantial concrete foundation with embedded conduit of various diameters to enable power, field and earth ground wiring to be routed into the cabinet. A mounting bolt positioner and basic mounting hardware components are included with each controller. Additional materials required to complete the installation must be obtained separately. A material list can be compiled by reading through the instructions completely prior to starting the installation.

⚠ CAUTION: For your protection and the safety of the product user, comply with all Caution and Warning Statements within this document. All installation practices must comply with all applicable national and/or local electrical and construction codes.

Foundation Construction

1. Prepare a hole for the foundation and wiring conduit using the minimum recommended dimensions shown in **Figure 1**.

Note: Refer to local electrical codes for required depth of buried wiring.

2. Trench to the foundation site as required for each wiring run.
3. Position the straight and sweep elbow conduit sections in the foundation hole as shown. Tape the conduit ends to seal out dirt. Backfill soil to form a 6" (15.2cm) foundation depth. Conduit should not extend more than 2" (51mm) above the finished top surface of the foundation.
4. Prepare the sides of the foundation hole with wood forms.
5. Prepare the mounting bolt positioner with the 5/16" x 4-1/2" bolts and nuts (provided) as shown in **Figure 1**. The threads should extend 2" (51mm) from the top surface of the bolt positioner.
6. Pour concrete into the formed foundation hole. Press the mounting bolt positioner into the concrete until it is flush and level with the foundation surface and aligned with the conduit.
7. Finish the concrete with a level flat area for the pedestal base (13" x 13" [33cm x 33cm] for the metal cabinet or 16" x 16" [41cm x 41cm] for the plastic cabinet). To prevent pooling at the base of the pedestal, add a slight taper away from the cabinet base contact area. Allow the concrete to sufficiently harden before continuing.
8. Remove the hex nuts from the mounting bolts. Place the pedestal on the pad ensuring all bolts pass through the holes provided. Install a flat washer and a hex nut on each bolt and tighten securely.

Figure 1

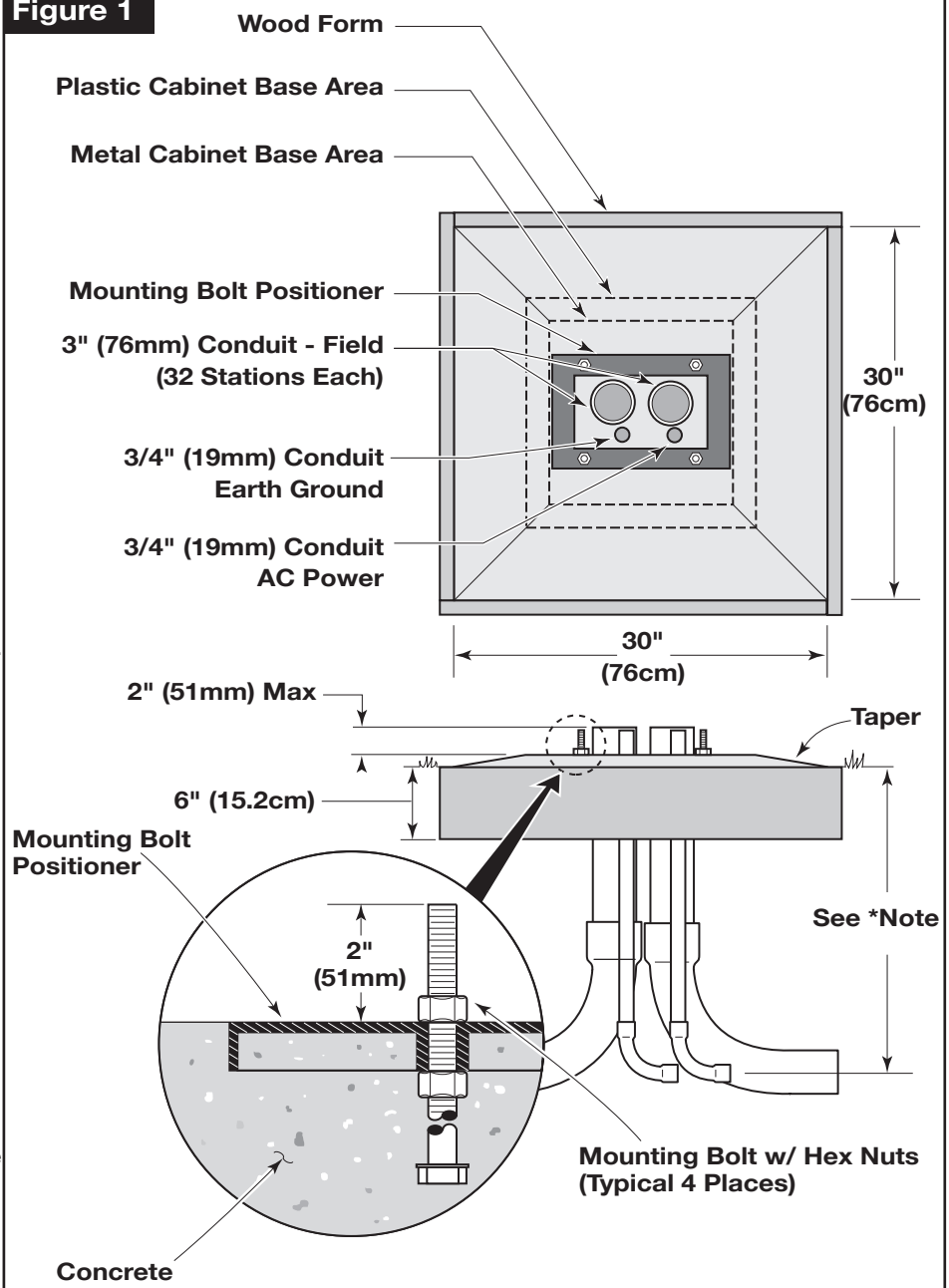

Earth Ground Installation

⚠ Important! Toro surge protection devices require an acceptable earth ground to dissipate excess energy. An earth ground is required in all cases, and a measured resistance of 10 ohms or less is recommended. If it is impractical to achieve a measured resistance of 10 ohms, the installation of ground rods, ground plates, and ground enhancement material per the grounding material manufacturer's instructions is recommended. It is further recommended that all earth grounds and surge protection devices be checked yearly and after each lightning event. Toro advises against the use of a bonding/shielding wire in conjunction with Toro irrigation control systems. Grounding materials or equipment that are not specified in these instructions should not be connected to the Toro control products, Toro communication/power wiring or the grounding for the communication/power wiring. All electrical equipment grounds must meet local electrical codes.

Procedure

1. Drive a 5/8" (16mm) by 8' (2.5m) copper-clad steel rod into well-moistened soil not more than 12' (3.7m) from the satellite. The top of the ground rod should be slightly below grade level.
2. Using a 5/8" (16mm) clamp or "Cad weld" fastener, attach a length of #6 (6mm²) solid copper wire near the top of the ground rod. Avoiding sharp bends, route the wire through the foundation into the controller cabinet. Secure the wire to the large copper ground lug provided on the power supply chassis. See **Figure 2**.

📝 Note: Make sure the soil surrounding the ground rod(s) remains well moistened at all times. The addition of some form of irrigation may be required if the satellite is installed in a non-irrigated location.

3. Measure the ground resistance per the instructions provided with the ground test instrument. If the resistance exceeds the acceptable limit, additional ground rod(s) can be installed at a distance equal to the buried depth of the first rod; i.e., 16' (4.9m).

📝 Note: A Toro Valve Cover, P/N 850-00, works well for covering the ground rod and providing access to the ground wire connection(s).

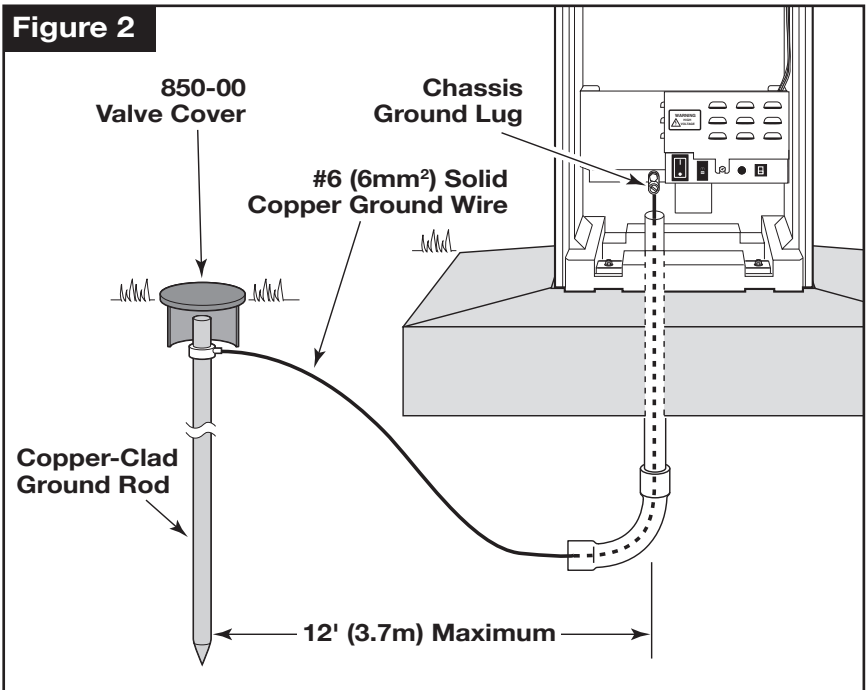

Input Power Installation

⚠ CAUTION: When installing multiple controllers, polarity of the Line and Neutral connections must be properly maintained throughout the irrigation system. Reversed polarity may cause damaging potentials to exist at one or more controller locations. An equipment ground wire from the power source must also be connected to the satellite power supply terminal block.



WARNING

AC POWER WIRING MUST BE INSTALLED AND CONNECTED BY QUALIFIED PERSONNEL ONLY. ALL ELECTRICAL COMPONENTS AND INSTALLATION PROCEDURES MUST COMPLY WITH ALL APPLICABLE LOCAL AND NATIONAL ELECTRICAL CODES. SOME CODES MAY REQUIRE A MEANS OF DISCONNECTION FROM THE AC POWER SOURCE, INSTALLED IN THE FIXED WIRING, HAVING A CONTACT SEPARATION OF AT LEAST 0.120" (3MM) IN THE LINE AND NEUTRAL POLES. ENSURE THE AC POWER SOURCE IS OFF PRIOR TO CONNECTING TO THE CONTROLLER.

1. Place the controller's main power switch in the Off position. See **Figure 3**.
 2. Position the input voltage select switch to the 115V (for 115-120V service) or 230V (for 230-240V service) as required.
 3. Remove the power wiring access cover located on the back of the power supply assembly. See **Figure 4**.

Note: The power and equipment ground wires are connected to a terminal block located on the back of the power supply assembly. The power wire access hole provided will accommodate a 3/4" (19mm) conduit fitting. If conduit is required by code, install a section of flexible 3/4" (19mm) electrical conduit from the foundation conduit to this access hole.
 4. Route the appropriate size 3-conductor cable (10 AWG [2.5mm²] maximum) from the power source location to the power supply terminal block.
 5. Reference Table 1 for the appropriate type of power connection. Secure the wires to the terminal block as indicated in **Figure 4**.
 6. Reinstall the power wiring access cover.
 7. Apply power to the controller.
- Note:** The satellite incorporates a 24 V a.c. Hot Post feature on each station output module which enables control valves to be identified through momentary activation. To utilize the Hot Post feature, the satellite power supply must be switched on. If you do not wish to use the Hot Post feature, leave the controller's main power switch Off until the installation has been completed. See **Figure 6**.

AC Service Type	Line	Equip. Grnd.	Neutral
115/120 V a.c. 50/60 Hz (Dom.)	Hot (Black)	Green	Neutral (White)
230/240 V a.c. 50/60 Hz (3-Phase)	Hot (Black)	Green/Yellow	Hot (Blue or Red)
230/240 V a.c. 50/60 Hz (Int)	Hot (Brown)	Green/Yellow	Neutral (Blue)

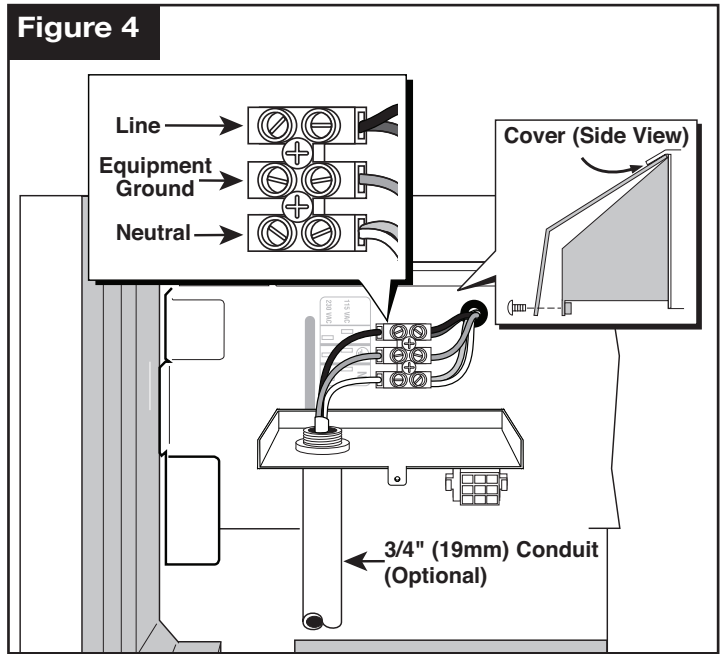
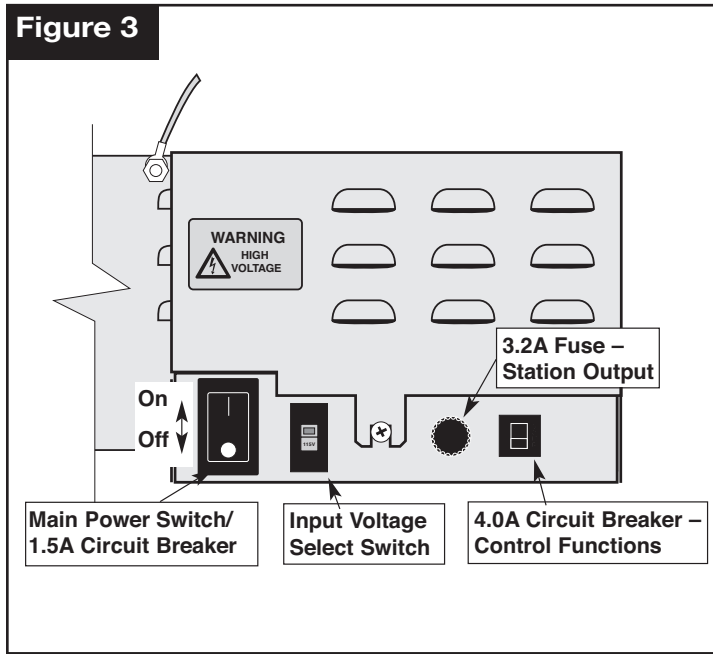

Field Wire Installation

CAUTION: The OSMAC G3 controller is capable of operating up to 12 stations simultaneously when operating with a pump, or 16 stations simultaneously without a pump. To prevent possible controller damage, total output current load must not exceed 3.2 amps. If more than one valve per station will be connected, calculate the total in-rush current load which would be imposed in the maximum operating conditions and use this value as a guide during installation and operation of the controller.

Procedure

1. Attach the control and common wires to each valve and/or valve-in-head solenoid leads using an approved waterproof splicing method. Route the wires into the controller cabinet through the 3" (76mm) conduit.
2. If an automatic pump start is required, refer to the applicable wiring diagram in Figure 5 (page 4) and install accordingly.

CAUTION: Do not connect the pump starter directly to the controller's pump start circuit – damage to the controller will result.

Note: The pump circuit can also be utilized to control a master valve if required.

Field Wire Installation (continued)

3. Secure the field common wire(s) and pump start relay (or master valve) wire to the appropriate terminals on the Pump/Com module. See Figure 6.
4. Momentarily touch each valve control wire to the Hot Post to activate and identify the corresponding valve(s).
5. Secure the valve control wires to the station terminals in the preferred order of operating sequence. Station terminals are numbered left to right, 1–32 (front) and 33–64 (back). Each terminal can accommodate two 14 gage (1.5mm²) solid copper wires. See Figure 6.

Note: A loop is provided on the plastic chassis below each output module enabling a wiring strain relief to be installed when the optional standard terminal block connector is used. After connecting the field wires, install a nylon cable tie through the loop and around the wire bundle. Ensure the terminal block is properly mated with the output module connector after tightening the cable tie. See Figure 6.

Note: The 3-position switches provided on the pump/com module and the optional station terminal board enable local control of the field common, pump circuit and station output. The switch positions are as follows:

ON (up) – Manually activates the circuit. The pump, field common or station output will remain on until the switch is moved to the AUTO or OFF position.

OFF (center) – Manually opens the circuit. Operation of the circuit will not occur while the switch is in this position.

AUTO (down) – Enables the circuit to be automatically controlled during automatic or manual (hand-held radio) operation.

CAUTION: To prevent damage to the station output circuit fuse, do not exceed 3 amp load when manually activating multiple station outputs.

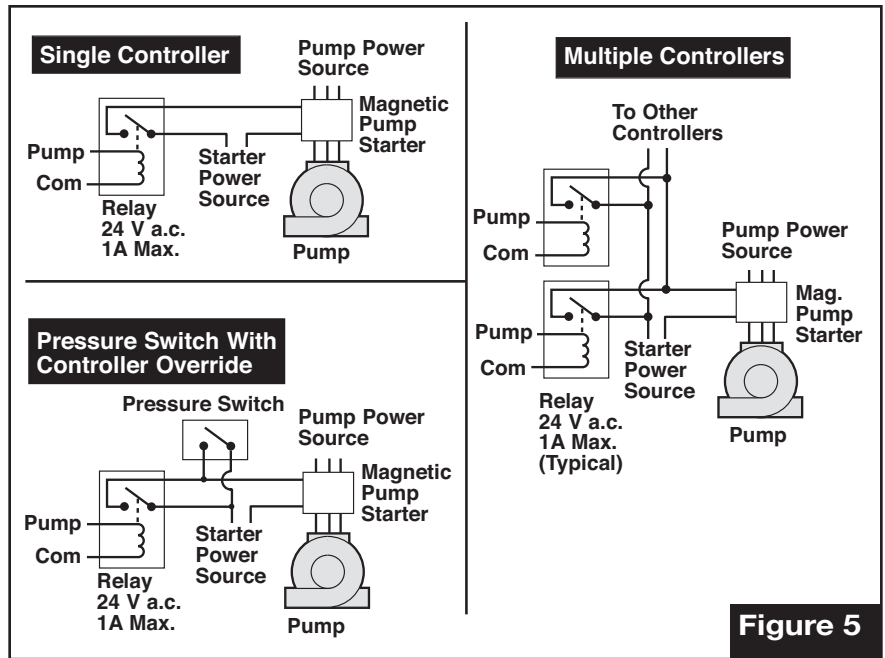

Figure 5

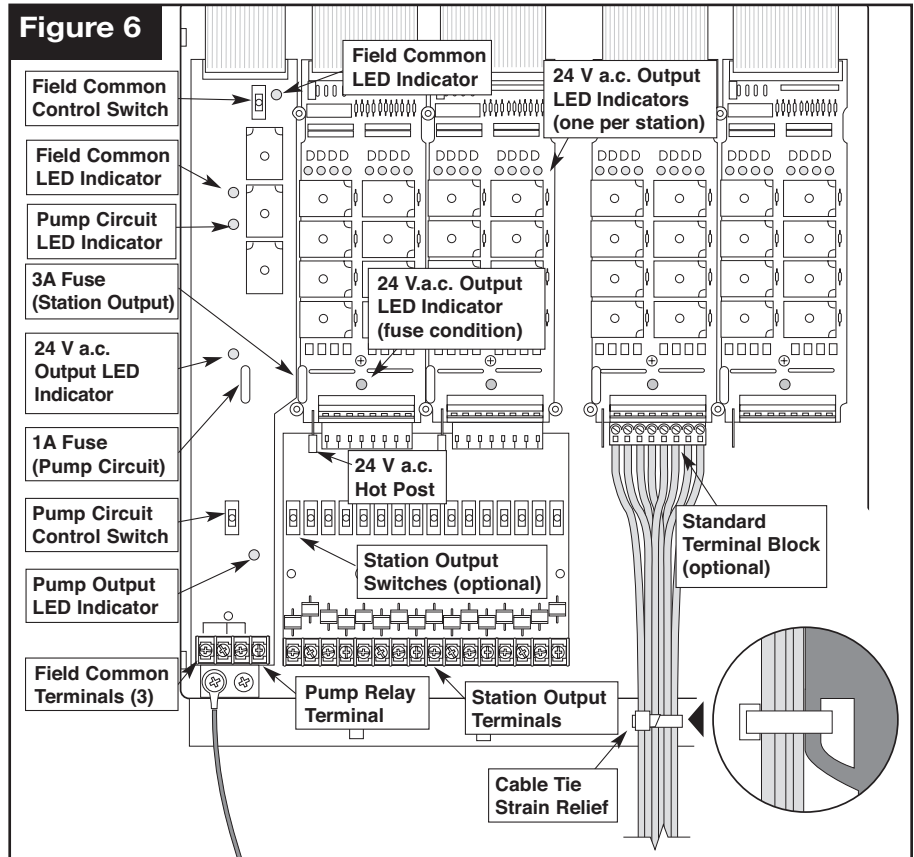

Figure 6

Selecting the Radio Frequency

The OSMAC G3 controller has 6 pre-programmed user-selectable radio frequencies. The frequencies are programmed at the factory or by the distributor prior to delivery of the satellite. However if a frequency change is desired, any of the 6 pre-programmed frequency channels can be modified to any desired radio frequency.

Important: The base station transmitter and satellite must be set to the same frequency to enable communication.

```

What's Running
Manual Watering
Scheduled Watering
Communication
Diagnostics
Setting
  
```

```

Page Monitor Sig
Page History
Radio Menu
Sat Address: 001
Comm Code: Central
Receive Only Radio
  
```

```

Radio Frequency
Radio Information
Radio Send Command
Promiscuous: No
WMX Enable: Yes
Reset Radio Defaults
  
```

```

Channel: 1
Rx Freq1 462.2125MHz
Tx Freq1 462.2125MHz a
  
```

```

Channel: 1
Rx Freq1 462.2125MHz
Tx Freq1 462.2125MHz a
  
```

1

1. While at the Home Screen, press to access the controller menu selection.
2. Use the or arrows to select **Communication** and press to access.
3. Use the or arrows to select **Radio Menu** and press to access.
4. Use the or arrows to select **Radio Frequency** and press to access.
5. While the cursor selection is on **Channel: 1**, press to select. Use the or arrows to scroll through the six pre-programmed frequency channels. Once the correct frequency is selected, press to activate.
6. If the desired frequency does not match any of the pre-programmed channels, any of the six channels can be modified. Follow Step 4 to select the channel you want to modify. Press arrow to access the frequency number. Use the or arrows to navigate between the frequency digits. Press and use the or to modify each number to the desired radio frequency.

Assigning the Satellite Address Number

Each satellite requires a 3-digit address number to enable communication with the central controller and/or a hand-held radio. The address numbers range from 1 (001) through 255.

```

What's Running
Manual Watering
Scheduled Watering
Communication
Diagnostics
Setting
  
```

```

Page Monitor Sig
Page History
Radio Menu
Sat Address: 001
Comm Code: Central
Receive Only Radio
  
```

1. While at the Home Screen, press to access the controller menu selection.
2. Use the or arrows to select **Communication** and press to access.
3. Use the or arrows to select **Sat Address** and press to access.
4. Use the or arrows to set the desired address for the satellite. Satellite address can be set to 001 through 255. Satellites that belong to the same irrigation zone and will receive the same radio commands may be set to the same satellite address.

Setting Time and Date

```

What's Running
Manual Watering
Scheduled Watering
Communication
Diagnostics
Settings
  
```

```

Clock Set: 11:15am
Clock Mode: Am/Pm
Date Mode: MMDDYY
Date: 01/01/16 Fri
Sat Address: 001
Max Sim Sta: 05
  
```

```

Clock Set: 11:15am
Clock Mode: Am/Pm
Date Mode: MMDDYY
Date: 01/01/16 Fri
Sat Address: 001
Max Sim Sta: 05
  
```

1. While at the Home Screen, press to access the controller menu selection. Press the arrow repeatedly until **Settings** is selected and press .
2. To set the time, press the arrow until **Clock Set** is selected and press . Use the or arrows to navigate between Hours and Minutes. Use the or arrows to set the values. Press to finalize.
3. To set the date, press the arrow until **Date** is selected and press . Use the or arrows to navigate between days, months and year. Use the or arrows to set the values. Press to finalize.

Satellite Operations Using a Hand-Held Radio

The following list of satellite operations can be initiated in the field using a hand-held radio keypad. All operation commands must begin with the following keypad sequence: * 9 followed by the 3-digit satellite address number. The command code is then entered, followed by additional digits which represent selected stations and/or run time values. All station numbers from 1–9 must be entered with a preceding 0; i.e., station 1 is entered as 01.

Example: Confirm communication to the satellite by issuing a manual station start command as follows: Press * 9, the 3-digit satellite address code, command code 7521 and 01 (station 1). An audible click should be heard from the station relay and the corresponding station output LED should turn on. Visually check for sprinkler operation. To step forward through the stations, press * 1; to step back through the stations, press * 2. To terminate the test, use command code 7520.

Command Code	Operation Description
7510	Turns off individual stations; e.g., 7510 01 02 40 turns off stations 1, 2 and 40.
7511	Turns on individual stations; e.g., 7511 01 02 40 turns on stations 1, 2 and 40.
7512	Syringes individual stations for a predetermined number of 30-second intervals (already defined in the satellite); e.g., 7512 01 02 turns on stations 1 and 2 for 30-second intervals.
7513	Disables individual stations; e.g., 7513 01 03 disables stations 1 and 3. After this command, on and off commands will be ignored for stations 1 and 3 until the stations are re-enabled. (See 7514.)
7514	Enables individual stations; e.g., 7514 01 03 enable stations 1 and 3.
7515	Sequentially syringes a specified station number range; e.g., 7515 10 20 will syringe stations 10 through 20 sequentially.
7516	Sequentially syringes individual stations; e.g., 7516 10 11 will syringe stations 10 and 11. Multiple syringe groups can also be run. Enter two dashes between stations to designate separate syringe groups; e.g., 7516 10 11 - - 22 24 26 28 will run two sequential syringes at the same time on stations 10 and 11 and stations 22, 24, 26 and 28.
7517	Turns on individuals stations for a specified number of hours, minutes and seconds; e.g., 7517 01 30 00 23 24 25 turns stations 23, 24 and 25 on for 1 hour, 30 minutes and no seconds.
7518	Turns on individual stations for a specified number of minutes; e.g., 7518 10 23 24 25 turns on stations 23, 24 and 25 for 10 minutes.
7520	Turns off a sequential station run operation (initiated by command code 7521).
7521	Turns on a sequential station run operation; e.g., 7521 01 turns on station 1. To step forward through the stations, press * 1; to step back through the stations, press * 2.
7524	Turns on individual stations as switches; i.e., does not simultaneously energize the pump. Note: Will not turn off the pump if already running. E.g., 7524 25 35 45 turns on stations 25, 35 and 45 without energizing the pump.
7525	Turns on individual stations as switches for a time given in minutes; i.e., does not simultaneously energize the pump in this command string, the run time is entered first, followed by the station numbers; e.g., 7525 25 05 42 turns on stations 5 and 45 for 25 minutes without energizing the pump.
7526	Turns on individual stations as switches for the time given in hours, minutes and seconds. In this command string, the run time is entered first, followed by the station numbers; e.g., 7526 02 30 45 25 26 27 turns on stations 25, 26 and 27 for 2 hours, 30 minutes and 45 seconds.
7540	Turns off all stations (this satellite only).
7543	Disables all stations in all satellites (rain shutdown). Note: Satellite address code is not used with 7543 or 7544 command codes. The stations will not respond to any further commands until enabled.
7544	Enables operation of all stations in all satellites. See Note above.
7546	Sequentially syringes all stations for a set length of time; e.g., 7546 turns on all stations for the predetermined number of 30 second intervals as defined in the syringe time.
8000	Disables pump start.
8001	Enables pump start to be assigned to a station; e.g., 8001 48 assigns pump start to station 48.
8003 00	Disables operation and turns off all stations in the satellite with sequential shutdown.
8003 01	Enables operation of all stations in the satellite.
8004	Changes the password; e.g., 8004 7531 6108 will change the factory default password (7531) to 6108.

Command Code	Operation Description
8006 01	Sets the syringe time in 30-second intervals; e.g., 8006 01 0100 (without a password) or 8006 pppp 01 0100 (with a password) sets the syringe time to 100 intervals (50 minutes). The number of intervals must be given as four digits with leading zeros but can be no greater than 0255.
8006 03	Enables/disables the password. Use 8007 03 01 to enable password protection or 8007 03 00 to cancel password protection.
8008	Configures stations as switches. Stations can be specified individually and in combination with a range of stations; e.g., 8008 01 12 50 – 60 configures stations 1, 12 and 50 through 60 as switches. Note: Only a single dash is used when entering a range of stations.
8009	Configures stations for irrigation. Stations can be specified individually and in combination with a range of stations; e.g., 8009 01 20 45 – 48 configures stations 1, 20 and 45 through 48 for irrigation.
8011	Resets to factory defaults.

Installing Additional 8-Station Output Modules

The OSMAC G3 controller can be upgraded to a maximum of 64 station outputs with the addition of 8-station output modules and optional terminal boards. The station module is supplied with the required mounting hardware and connector cable.

Note: Each of the eight output module positions has a specific station number assignment. An output module can be installed in any open position. The controller recognizes the module station order as follows:

(Front, left to right)

Module position 1 = Stations 1–8

Module position 2 = Stations 9–16

Module position 3 = Stations 17–24

Module position 4 = Stations 25–32

(Back, left to right)

Module position 1 = Stations 33–40

Module position 2 = Stations 41–48

Module position 3 = Stations 49–56

Module position 4 = Stations 57–64

Installation Procedure (Refer to Figure 7)

1. Switch power supply Off.
2. Place the 8-station module onto the backplate, positioning it between the four guideposts. Carefully press inward at the top of the module board to engage the plastic latch.
3. Ground and secure the module to the backplate assembly using the single machine screw provided. *Important: The machine screws connect the output and station modules to the 24V power and ground bus bars and must be installed in the designated locations as indicated in Figure 10. Do not attempt to use self-tapping screws in these locations.
4. Install the ribbon cable to the 8-station module and output distribution board receptacles as shown. The ribbon cable connectors are keyed to insert in only one direction.
5. Insert the optional station output terminal board assembly connector or standard terminal block to the station module receptacle. Secure the terminal board assembly to the chassis with three self-tapping screws and two machine screws provided.
6. Connect the valve wiring as described on page 4.
7. Switch power supply On.

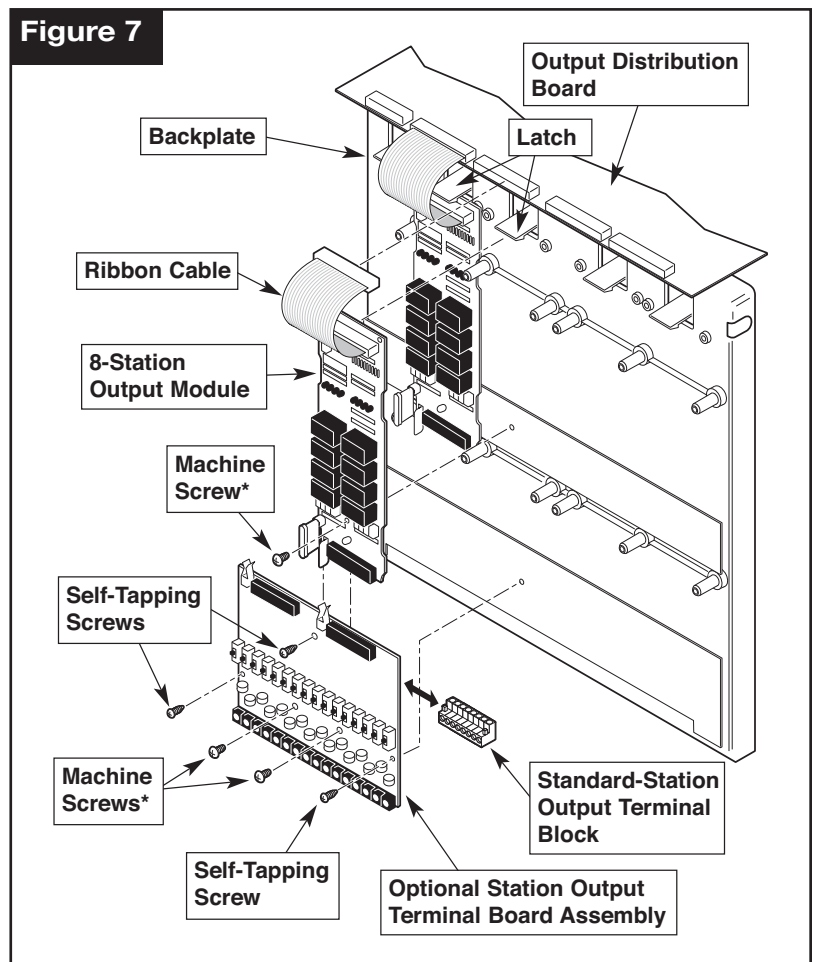

Specifications

Line Voltage: 115-120 or 230-240 V a.c. 50/60 Hz (switchable), 130 VA
Current Draw (no load): 0.21A @ 115-120 V a.c., 60 Hz or 0.10A @ 230-240 V a.c., 50 Hz
Current Draw (maximum load): 0.91A @ 115-120 V a.c., 60 Hz or 0.45A @ 230-240 V a.c., 50 Hz
Secondary Voltage Output: 24 V a.c., 50/60 Hz, 3.0A (85 VA)
Maximum Load Per Station Output: 0.75A (18 VA)
Maximum Load Per Pump/Master Valve Output: 1A (24 VA)
Operating Temperature: -10°C to +60°C (14°F to 140°F)
Storage Temperature: -30°C to +65°C (-22°F to 149°F)

Hardware Features

Plastic or painted stainless-steel cabinetry
Front, back and top locking covers
Modular station output capacity upgradeable in 8-station increments. (48-station maximum when used in conjunction with TouchNet; 64-station maximum with SitePro.)
Optional output terminal board configurations in 16-station increments
Optional antenna adapter kit available.

Fuses and Circuit Breakers

Power Supply:

1.5A On/Off Switch/Circuit Breaker – Main Power Input
3.2A Fuse – Power Supply (Slow Blow)
4.0A Circuit Breaker – Control Functions

Control Modules:

Pump – 1.0A Fuse (Fast Blow, Automotive Type)
Station Output – 3.0A Fuse (Fast Blow, Automotive Type)



WARNING

IF FUSE REPLACEMENT IS REQUIRED, REPLACE WITH A FUSE OF THE SAME TYPE AND AMPERAGE RATING. FAILURE TO COMPLY CAN RESULT IN SERIOUS INJURY AND/OR EQUIPMENT DAMAGE DUE TO FIRE HAZARD.

Electronic Compatibility

Domestic: This equipment generates and uses radio frequency energy and if not installed and used properly, that is, in strict accordance with the manufacturer's instructions, may cause interference to radio and television reception. It has been type tested and found to comply with the limits for a FCC Class B computing device in accordance with the specifications in Subpart J of Part 15 of FCC Rules, which are designed to provide reasonable protection against such interference in a residential installation. However, there is no guarantee that interference will not occur in a particular installation. If this equipment does cause interference to radio or television reception, which can be determined by turning the equipment off and on, the user is encouraged to try to correct the interference by one or more of the following measures:

- Reorient the receiving antenna.
- Relocate the irrigation controller with respect to the receiver.
- Move the irrigation controller away from the receiver.

If necessary, the user should consult the dealer or an experienced radio/television technician for additional suggestions. The user may find the following booklet prepared by the Federal Communications Commission helpful:

“How to Identify and Resolve Radio-TV Interference Problems.” This booklet is available from the U.S. Government Printing Office, Washington, DC 20402. Stock No. 004-000-00345-4.

International: This is a CSPR 22 Class B product.