



HoverPro® 450 and 550 Machines

Model No. 02610—Serial No. 403230000 and Up

Model No. 02611—Serial No. 402000000 and Up

Operator's Manual

Introduction

Read this information carefully to learn how to operate and maintain your product properly and to avoid injury and product damage. You are responsible for operating the product properly and safely.

You may contact Toro directly at www.Toro.com for product safety and operation training materials, accessory information, help finding a dealer, or to register your product.

Whenever you need service, genuine Toro parts, or additional information, contact an Authorized Service Dealer or Toro Customer Service and have the model and serial numbers of your product ready. **Figure 1** identifies the location of the model and serial numbers on the product. Write the numbers in the space provided.

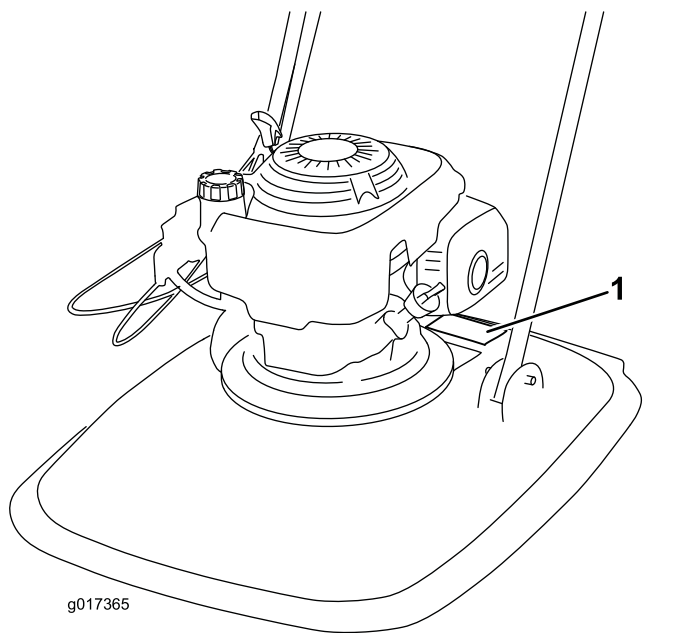

Figure 1

1. Model and serial number plate

<p>Model No. _____</p> <p>Serial No. _____</p>
--

This manual identifies potential hazards and has safety messages identified by the safety-alert symbol (**Figure 2**), which signals a hazard that may cause serious injury or death if you do not follow the recommended precautions.



Figure 2
Safety-alert symbol

g000502

This manual uses 2 words to highlight information. **Important** calls attention to special mechanical information and **Note** emphasizes general information worthy of special attention.

It is a violation of California Public Resource Code Section 4442 or 4443 to use or operate the engine on any forest-covered, brush-covered, or grass-covered land unless the engine is equipped with a spark arrester, as defined in Section 4442, maintained in effective working order or the engine is constructed, equipped, and maintained for the prevention of fire.

This machine does not come equipped with a spark arrester standard. You must install the spark arrester kit before operating this machine in California.

The enclosed engine owner's manual is supplied for information regarding the US Environmental Protection Agency (EPA) and the California Emission Control Regulation of emission systems, maintenance, and warranty. Replacements may be ordered through the engine manufacturer.

For models with stated engine horsepower, the gross horsepower of the engine was laboratory rated by the engine manufacturer in accordance with SAE J1349. As configured to meet safety, emission, and operating requirements, the actual engine horsepower on this class machine will be significantly lower.



⚠ WARNING

CALIFORNIA Proposition 65 Warning

The engine exhaust from this product contains chemicals known to the State of California to cause cancer, birth defects, or other reproductive harm.

Use of this product may cause exposure to chemicals known to the State of California to cause cancer, birth defects, or other reproductive harm.

Contents

Introduction	1
Safety	2
General Safety	2
Safety and Instructional Decals	3
Setup	4
1 Assembling the Handle	4
2 Installing the Footstop	6
3 Filling the Engine with Oil	6
Product Overview	7
Specifications	8
Operation	8
Before Operation	8
Before Operation Safety	8
Filling the Fuel Tank	8
Checking the Engine-Oil Level	9
Adjusting the Cutting Height	10
During Operation	10
During Operating Safety	10
Starting the Engine	11
Adjusting the Choke	12
Shutting Off the Engine	12
Operating Tips	13
After Operation	14
After Operating Safety	14
Cleaning the Machine	14
Maintenance	15
Recommended Maintenance Schedule(s)	15
Maintenance Safety	15
Preparing for Maintenance	16
Servicing the Air Filter	16
Changing the Engine Oil	17
Servicing the Spark Plug	17
Replacing the Blade	18
Storage	19
Preparing the Machine for Storage	19
Troubleshooting	20

Safety

This machine has been designed in accordance with ANSI B71.4-2012.

General Safety

This product is capable of amputating hands and feet and of throwing objects. Always follow all safety instructions to avoid serious personal injury.

Using this product for purposes other than its intended use could prove dangerous to you and bystanders.

- Read and understand the contents of this *Operator's Manual* before starting the engine.
- Do not put your hands or feet near moving components of the machine.
- Do not operate the machine without all guards and other safety protective devices in place and working on the machine.
- Keep clear of any discharge opening. Keep bystanders a safe distance away from the machine.
- Keep children out of the operating area. Never allow children to operate the machine.
- Stop the machine and shut off the engine before servicing, fueling, or unclogging the machine.

Improperly using or maintaining this machine can result in injury. To reduce the potential for injury, comply with these safety instructions and always pay attention to the safety-alert symbol, which means Caution, Warning, or Danger—personal safety instruction. Failure to comply with these instructions may result in personal injury or death.

You can find additional safety information where needed throughout this manual.

Safety and Instructional Decals



Safety and instructional decals are easily visible and are located near areas of potential danger. Replace any damaged or missing decal.

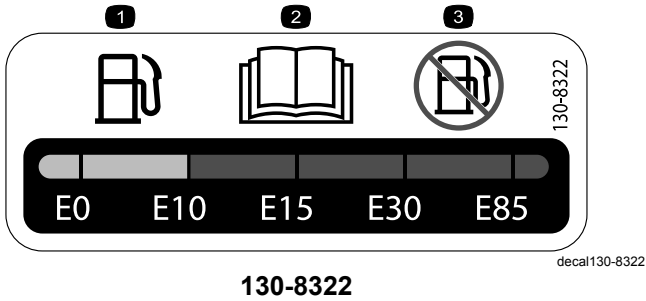

130-8322

1. Use only fuel with an alcohol content by volume under 10%.
2. Read the *Operator's Manual* for more information on fuel.
3. Do not use fuel with an alcohol content by volume greater than 10%.

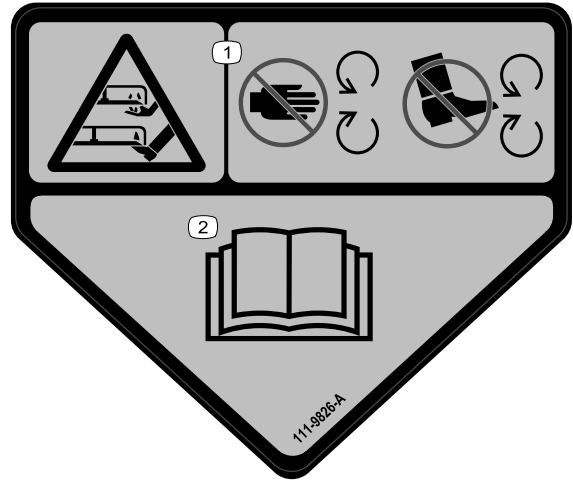

111-9826

decal111-9826

1. Cutting/dismemberment hazard of hand or foot, cutting unit—keep your hands and feet away from moving parts.
2. Read the *Operator's Manual*.

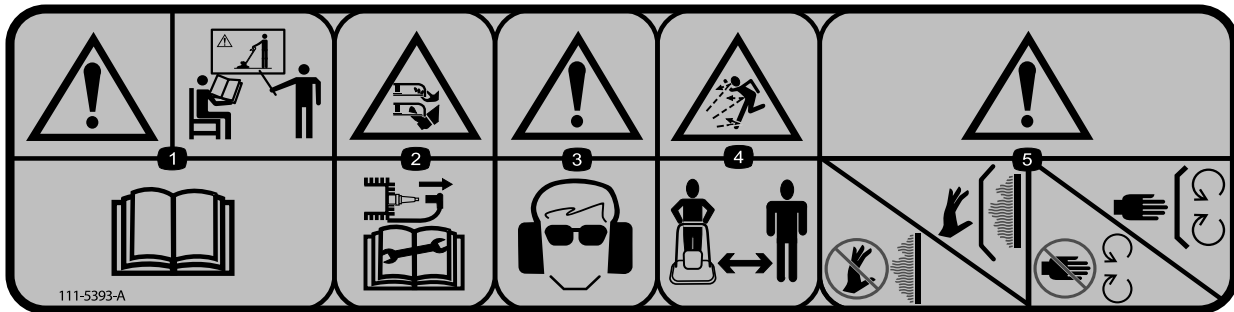

111-5393

decal111-5393

1. Warning—Receive training on the product; read the *Operator's Manual*.
2. Cutting/dismemberment hazard of hand or foot, mower blade; disconnect the wire from the spark plug before working on the machine; never fit metal cutting parts.
3. Warning—wear eye and hearing protection.
4. Thrown object hazard; keep bystanders away from the machine.
5. Warning—do not touch hot surfaces; keep guards in place; Stay away from moving parts; keep guards in place.



94-8072

decal94-8072

1. Warning—cutting/dismemberment hazard of hand or foot, cutting mechanism.



g017410

H295159

g017410

1. Engine stop (shut off)

▲ WARNING: Cancer and Reproductive Harm - www.P65Warnings.ca.gov.
For more information, please visit www.tccoCProp65.com

CALIFORNIA SPARK ARRESTER WARNING

Operation of this equipment may create sparks that can start fires around dry vegetation. A spark arrester may be required. The operator should contact local fire agencies for laws or regulations relating to fire prevention requirements.

decal133-8062

133-8062

Setup

1

Assembling the Handle

No Parts Required

Procedure

1. Slide 2 bushings into the frame.

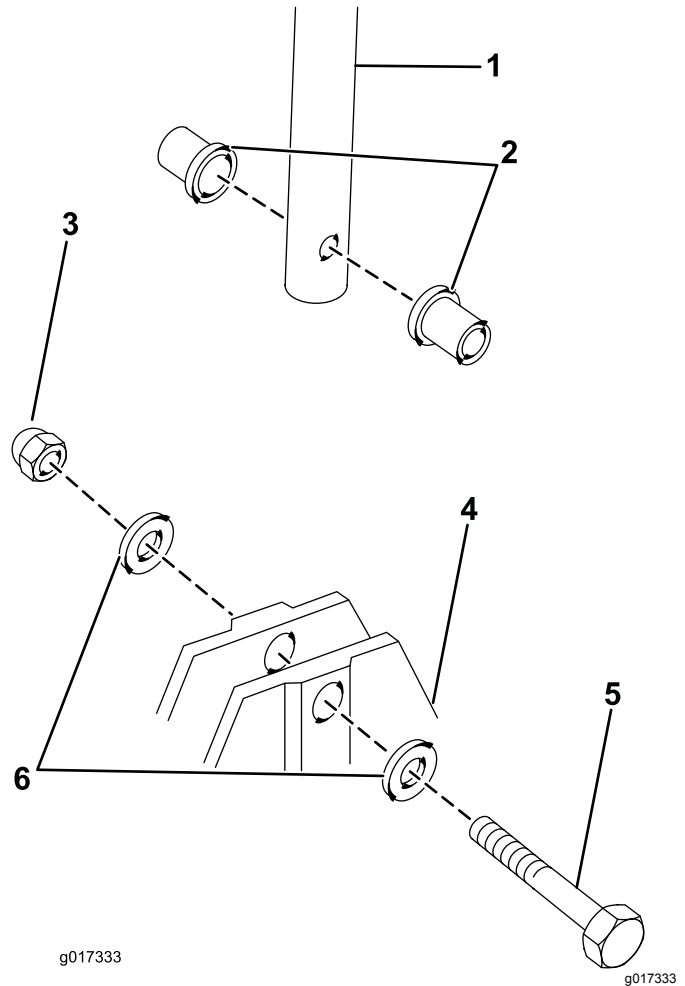

Figure 3

- | | |
|-----------------|------------|
| 1. Lower handle | 4. Frame |
| 2. Bushings | 5. Bolt |
| 3. Nut | 6. Washers |

2. Place the lower handle between the bushings and secure it with 1 handlebar bolt, 2 washers, and 1 nut.

Note: Place the lower handle between the bushings with the kick stop assembly at the right side.

3. Repeat for the opposite side.
4. Align the holes on the upper handle with the lower handle.

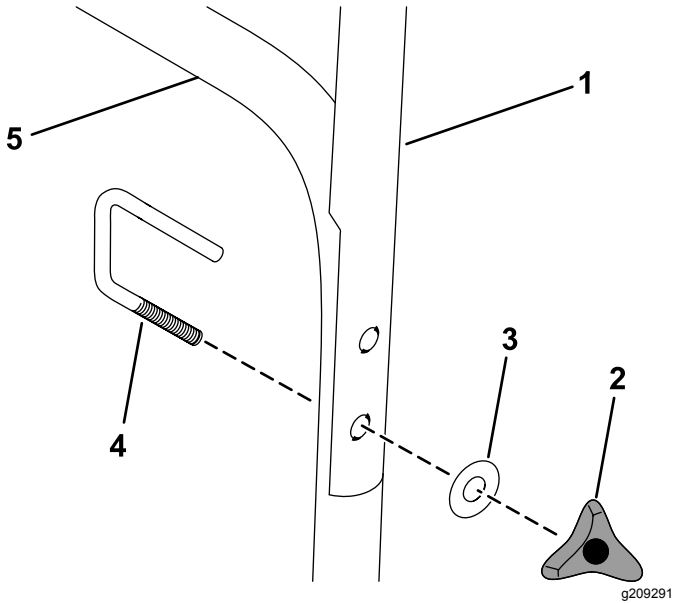

Figure 4

- | | |
|-----------------|-----------------|
| 1. Upper handle | 4. U-bolt |
| 2. Hand wheel | 5. Lower handle |
| 3. Washer | |

5. Fit the U-bolt through the upper and lower handle and secure it with a washer and a hand wheel.
6. Attach the throttle assembly to the outside of the handlebar and secure it with a nut and a pan screw.

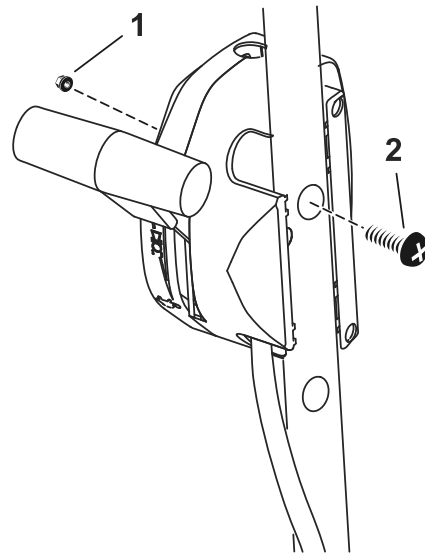

Figure 5

g209280

- | | |
|--------|--------------|
| 1. Nut | 2. Pan screw |
|--------|--------------|

2

Installing the Footstop

No Parts Required

Procedure

Secure the footstop to the bolt on the right side of the lower handle using a nut and 2 washers (Figure 6).

Note: Install the footstop using the lower hole in the footstop as shown in Figure 6.

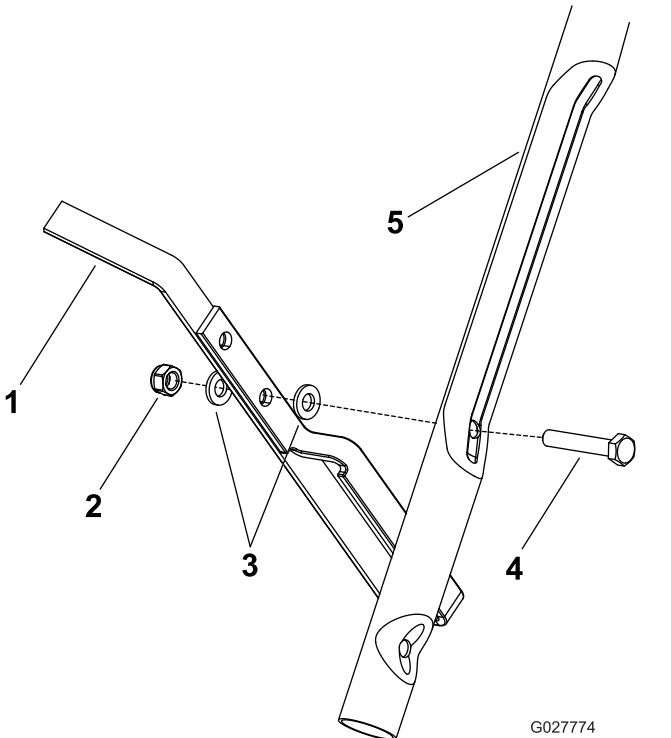

Figure 6

G027774
g027774

- 1. Footstop
- 2. Nut
- 3. Washer
- 4. Bolt
- 5. Lower handle

3

Filling the Engine with Oil

No Parts Required

Procedure

Important: Your machine does not come with oil in the engine. Before starting the engine, fill the engine with oil.

Engine Oil Specifications

Engine oil capacity	0.59 L (20 fl oz)
Oil viscosity	SAE 10W-30 multigrade mineral oil
API service classification	SJ or higher

1. Move the machine to a level surface.
2. Remove the dipstick by rotating the cap counterclockwise and pulling it out (Figure 7).

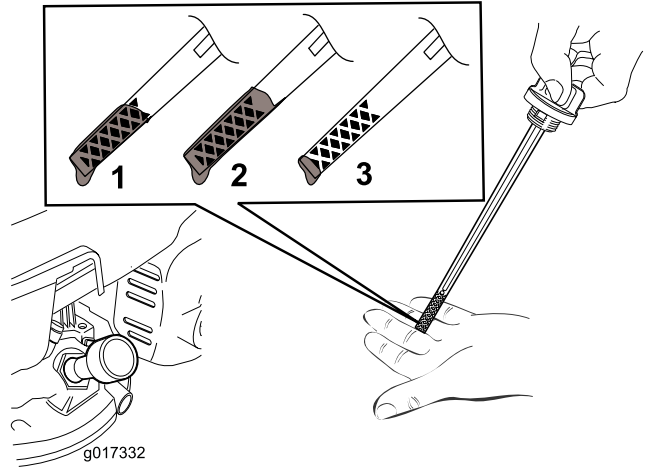

Figure 7

- 1. Full
- 2. High
- 3. Low

3. Carefully pour about 3/4 of the engine capacity of oil into the oil-fill tube (Figure 8).

Product Overview

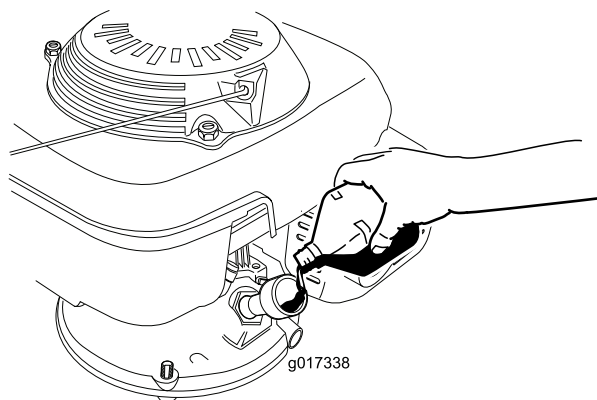

Figure 8

g017338

4. Wait 3 minutes for the oil to settle in the engine.
5. Wipe the dipstick clean with a clean cloth.
6. Insert the dipstick into the oil-fill tube, but do not screw it in, then remove the dipstick.
7. Read the oil level on the dipstick ([Figure 7](#)).
 - If the oil level on the dipstick is too low, carefully pour a small amount of oil into the oil-fill tube, wait 3 minutes, and repeat steps [5](#) through [7](#) until the oil on the dipstick is at the correct level.
 - If the oil level on the dipstick is too high, drain the excess oil until the oil on the dipstick is at the correct level; refer to [Changing the Engine Oil \(page 17\)](#).

Important: If the oil level in the engine is too low or too high and you run the engine, you may damage the engine.

8. Install the dipstick and hand tighten it securely.

Important: Change the engine oil after the first 5 operating hours; change it yearly thereafter. Refer to [Changing the Engine Oil \(page 17\)](#).

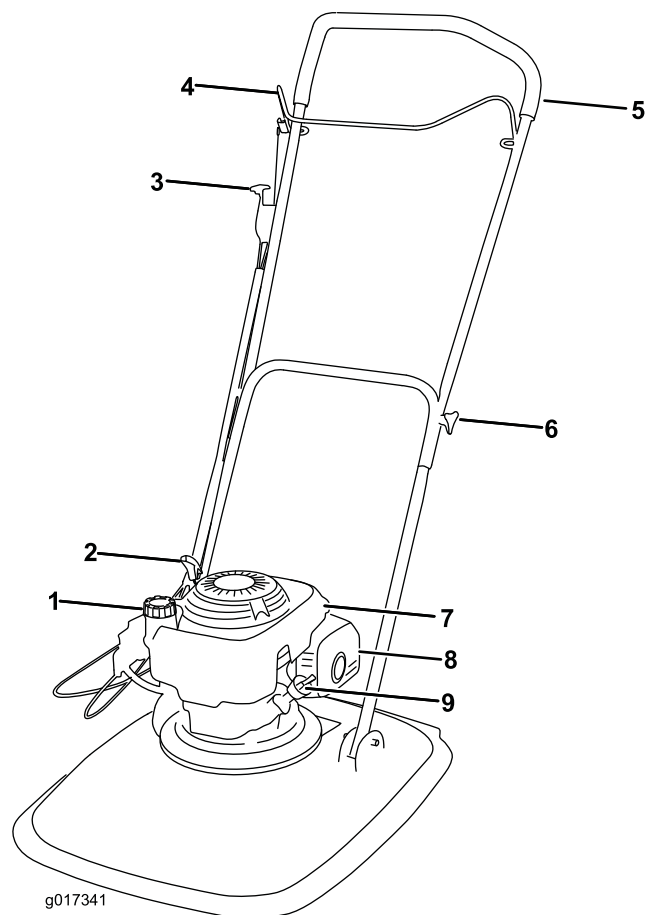

Figure 9

g017341

- | | |
|------------------------------|----------------------------|
| 1. Fuel cap | 6. Handlebar securing knob |
| 2. Engine start | 7. Engine cover |
| 3. Throttle control | 8. Exhaust guard |
| 4. Operator-presence control | 9. Dipstick |
| 5. Handlebar | |

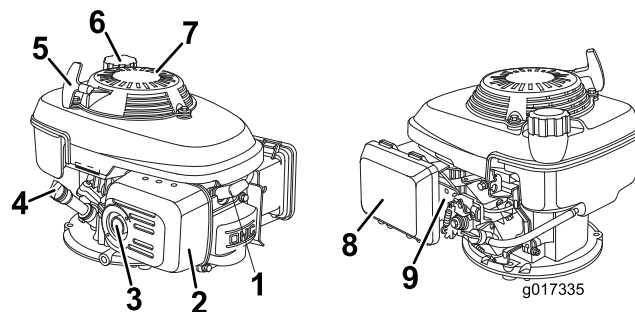

Figure 10

g017335

- | | |
|------------------|-----------------|
| 1. Spark plug | 6. Fuel cap |
| 2. Exhaust guard | 7. Finger guard |
| 3. Exhaust | 8. Air cleaner |
| 4. Dipstick | 9. Carburetor |
| 5. Starter grip | |

Specifications

Model	Cutting width	Product width
02610	46.5 cm (18-1/2 inches)	57.5 cm (22-1/2 inches)
02611	53.5 cm (21 inches)	63.5 cm (25 inches)

Operation

Note: Determine the left and right sides of the machine from the normal operating position.

Before Operation

Before Operation Safety

General Safety

- Become familiar with the safe operation of the equipment, operator controls, and safety signs.
- Check that all guards and safety devices are in place and working properly.
- Always inspect the machine to ensure that the blades, blade bolts, and cutting assembly are not worn or damaged.
- Inspect the area where you will use the machine and remove all objects that the machine could throw.
- Adjusting the cutting height may bring you into contact with the moving blade, causing serious injury.
 - Shut off the engine and wait for all moving parts to stop.
 - Disconnect the spark-plug wire from the spark plug before adjusting the cutting height.

Fuel Safety

⚠ DANGER

Fuel is extremely flammable and highly explosive. A fire or explosion from fuel can burn you and others and can damage property.

- To prevent a static charge from igniting the fuel, place the container and/or machine directly on the ground before filling, not in a vehicle or on an object.
- Fill the fuel tank outdoors, in an open area, when the engine is cold. Wipe up any fuel that spills.
- Do not handle fuel when smoking or around an open flame or sparks.
- Store fuel in an approved container and keep it out of the reach of children.

⚠ WARNING

Fuel is harmful or fatal if swallowed. Long-term exposure to vapors can cause serious injury and illness.

- Avoid prolonged breathing of vapors.
- Keep your hands and face away from the nozzle and the fuel-tank opening.
- Keep fuel away from your eyes and skin.

Filling the Fuel Tank

- For best results, use only clean, fresh, unleaded gasoline with an octane rating of 87 or higher ((R+M)/2 rating method).
- Oxygenated fuel with up to 10% ethanol or 15% MTBE by volume is acceptable.
- **Do not** use ethanol blends of gasoline, such as E15 or E85, with more than 10% ethanol by volume. Performance problems and/or engine damage may result, which may not be covered under warranty.
- **Do not** use gasoline containing methanol.
- **Do not** store fuel either in the fuel tank or in fuel containers over the winter unless fuel stabilizer has been added to the fuel.
- **Do not** add oil to gasoline.

Fill the fuel tank with fresh unleaded regular gasoline from a major name-brand service station (Figure 11).

Important: To reduce starting problems, add fuel stabilizer/conditioner to fresh fuel as directed by the fuel-stabilizer manufacturer.

Refer to your engine owner's manual for additional information.

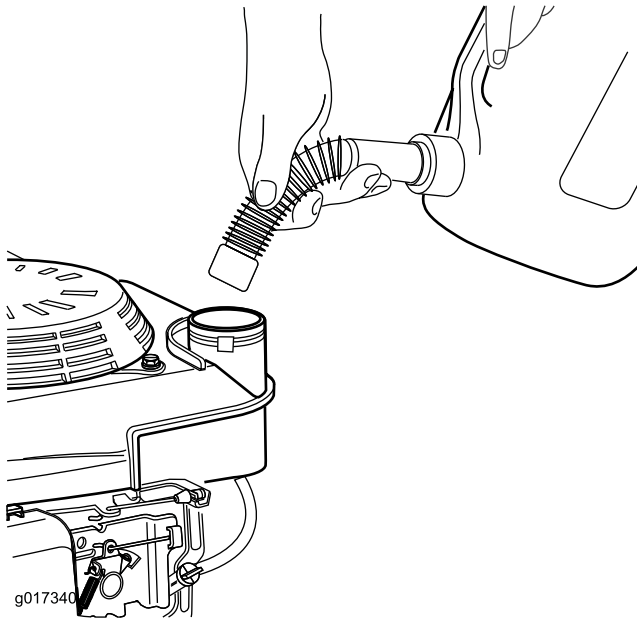

Figure 11

- If the oil level on the dipstick is too low (Figure 12), carefully pour a small amount of multigrade mineral SAE 10W-30 oil with an API series classification of SJ or higher into the oil-fill tube, wait 3 minutes, and repeat steps 3 through 5 until the oil on the dipstick is at the correct level.
- If the oil level on the dipstick is too high (Figure 12), drain the excess oil until the oil on the dipstick is at the correct level; refer to [Changing the Engine Oil \(page 17\)](#).

Important: If the oil level in the engine is too low or too high and you run the engine, you may damage the engine.

6. Install the dipstick into the oil-fill tube securely.

Important: Change the engine oil after the first 5 operating hours; change it yearly thereafter. Refer to [Changing the Engine Oil \(page 17\)](#).

Checking the Engine-Oil Level

1. Move the machine to a level surface.
2. Remove the dipstick by rotating the cap counterclockwise and pulling it out (Figure 12).

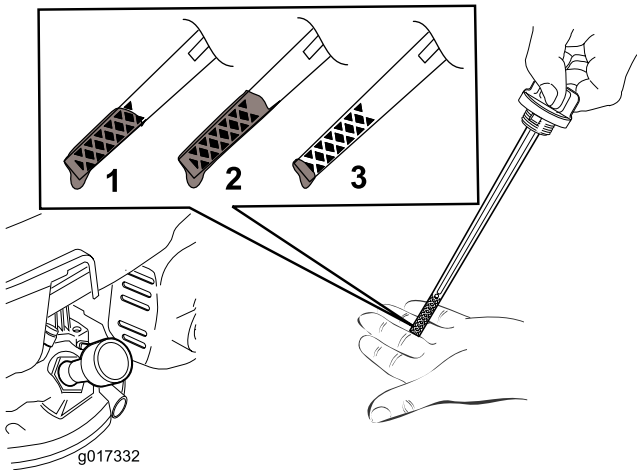

Figure 12

1. Full
2. High
3. Low

3. Wipe the dipstick clean with a clean cloth.
4. Insert the dipstick into the oil-fill tube, but do not screw it in, then remove the dipstick.
5. Read the oil level on the dipstick (Figure 12).

Adjusting the Cutting Height

⚠ WARNING

Adjusting the cutting height may bring you into contact with the moving blade, causing serious injury.

- Shut off the engine and wait for all moving parts to stop.
- Wear gloves while handling the cutting unit.

⚠ CAUTION

If the engine has been running, the muffler will be hot and can severely burn you.

Keep away from the hot muffler.

Adjust the cutting height as desired.

1. Turn the fuel switch to the OFF position.
2. Disconnect the wire from the spark plug.
3. Tip the machine on its side with the dipstick down.
4. Wearing protective gloves, remove the blade bolt and cutting unit.
5. Position the spacers to the desired height, then install the cutting unit as shown in [Figure 13](#).

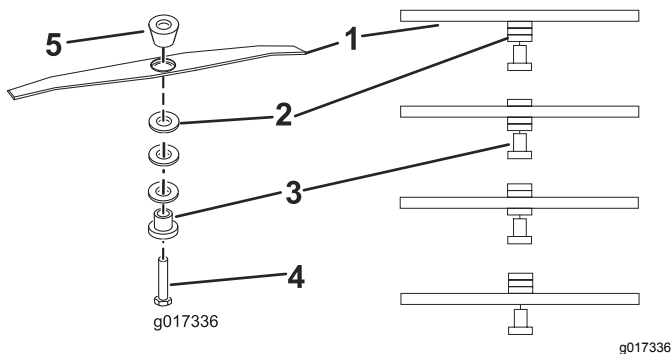

Figure 13

- | | |
|-------------------|-----------------|
| 1. Cutterbar | 4. Blade bolt |
| 2. Spacers | 5. Large spacer |
| 3. Blade retainer | |

Note: The large spacer must be directly below the impeller at all times.

6. Torque the blade bolt to 25 N·m (18 ft·lb).

During Operation

During Operating Safety

General Safety

- Wear appropriate clothing, including eye protection; long pants; substantial, slip-resistant footwear; and hearing protection. Tie back long hair and do not wear loose clothing or loose jewelry.
- Use your full attention while operating the machine. Do not engage in any activity that causes distractions; otherwise, injury or property damage may occur.
- Do not operate the machine while ill, tired, or under the influence of alcohol or drugs.
- The blade is sharp; contacting the blade can result in serious personal injury. Shut off the engine, and wait for all moving parts to stop before leaving the operating position.
- When you release the operator-presence control, the engine should shut off and the blade should stop within 3 seconds. If not, stop using your machine immediately and contact an Authorized Service Dealer.
- Operate the machine only in good visibility and appropriate weather conditions. Do not operate the machine when there is the risk of lighting.
- Wet grass or leaves can cause serious injury if you slip and contact the blade. Avoid mowing in wet conditions if possible.
- Use care when approaching blind corners, shrubs, trees, or other objects that may block your view.
- Watch for holes, ruts, bumps, rocks, or other hidden objects. Uneven terrain could cause a slip-and-fall accident.
- Stop the machine and inspect the blades after striking an object or if there is an abnormal vibration in the machine. Make all necessary repairs before resuming operation.
- Before leaving the operating position, shut off the engine, and wait for all moving parts to stop.
- If the engine has been running, the muffler will be hot and can severely burn you. Keep away from the hot muffler.
- Use accessories and attachments approved by The Toro® Company only.

Slope Safety

- Before operating on any slope, complete a site survey to determine the actual slope where you will operate the machine.
- Avoid mowing on wet grass. Poor footing could cause a slip-and-fall accident.
- Mow with caution near drop-offs, ditches, or embankments.
- When using the machine, always keep both hands on the handle.
- When cutting from the top of a steep slope and you need longer reach, use an approved extended handle if you need a longer reach.

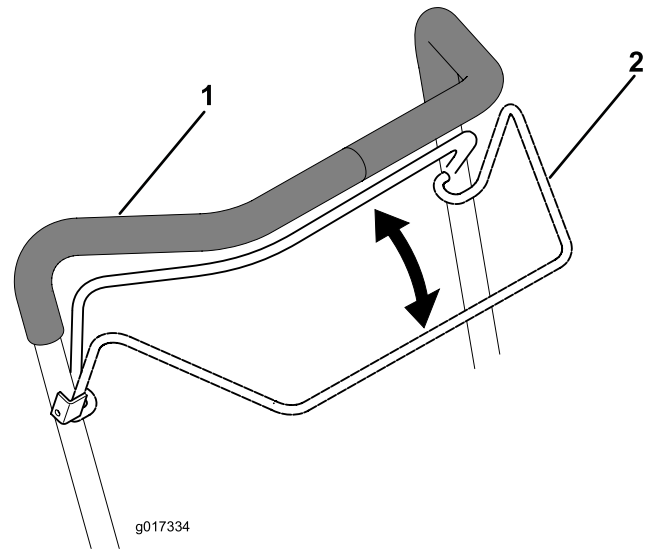

Figure 15

g017334

Starting the Engine

1. Place the throttle control to the choke position, ensure that the fuel switch is in the ON position.

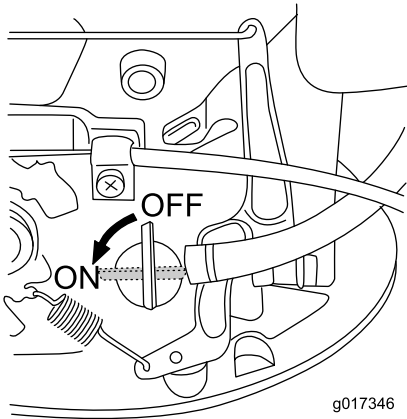

Figure 14

g017346

2. Hold the operator-presence control against the handle.

1. Handle
2. Operator-presence control

3. Place your foot on the deck and tilt the machine toward you (Figure 16).

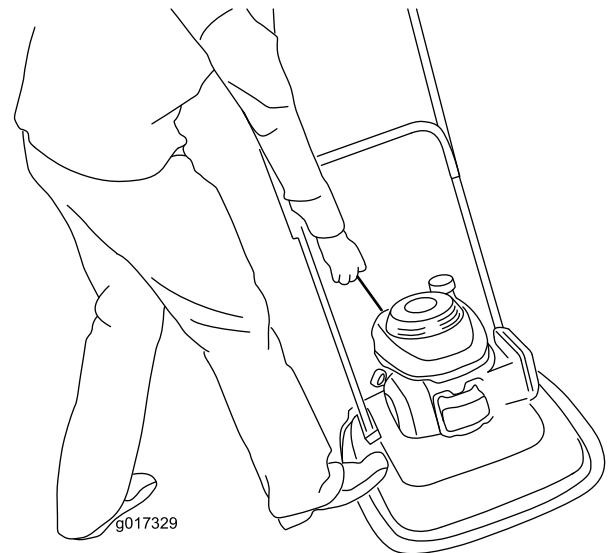

Figure 16

g017329

4. Pull the recoil-start handle.

Note: If the machine does not start after several attempts, contact an Authorized Service Dealer.

Adjusting the Choke

Use the throttle assembly to adjust the choke (Figure 17).

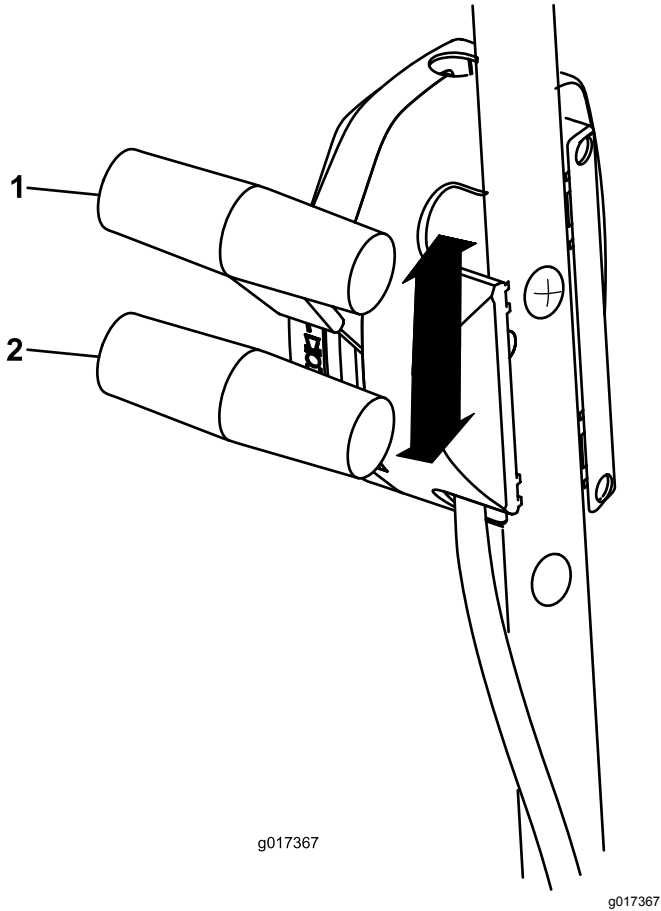

Figure 17

1. Choke on

2. Choke off

Shutting Off the Engine

Service Interval: Before each use or daily

To shut off the engine, release the operator-presence control (Figure 18).

Important: When you release the operator-presence control, both the engine and blade should stop within 3 seconds. If they do not stop properly, stop using your machine immediately and contact an Authorized Service Dealer.

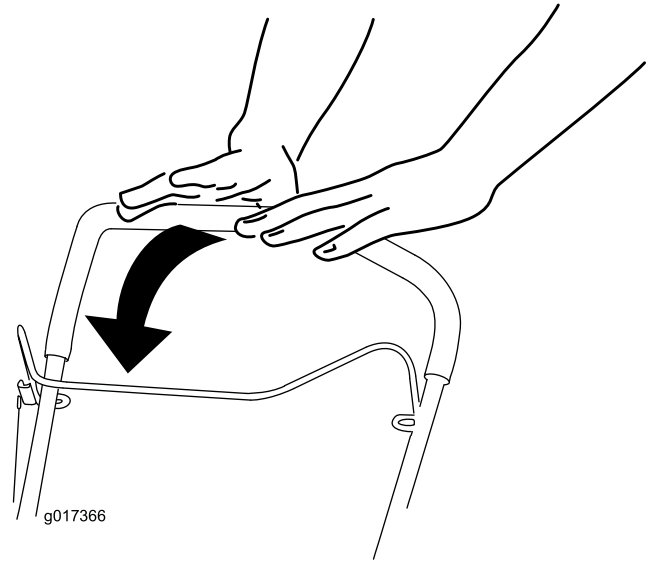

Figure 18

g017366

Operating Tips

General Mowing Tips

Important: Operating the machine on slopes of more than 45° will cause severe engine damage due to a lack of lubrication. Do not operate the machine on slopes greater than 45°.

- Inspect the area where you will use the machine and remove all objects that the machine could throw.
- Avoid striking solid objects with the blade. Never deliberately mow over any object.
- If the machine strikes an object or starts to vibrate, immediately shut off the engine, disconnect the wire from the spark plug, and examine the machine for damage.
- For best performance, install a new blade before the cutting season begins.
- Replace the blade when necessary with a Toro replacement blade.

Cutting Grass

- Cut only about a third of the grass blade at a time. Do not cut below the highest setting unless the grass is sparse or it is late fall when grass growth begins to slow down. Refer to [Adjusting the Cutting Height \(page 10\)](#).
- Mowing grass over 15 cm (6 inches) in length is not recommended. If the grass is too long, the machine may plug and cause the engine to stall.
- Wet grass and leaves tend to clump on the yard and can cause the machine to plug or the engine to stall. Avoid mowing in wet conditions.

⚠ WARNING

Wet grass or leaves can cause serious injury if you slip and contact the blade. Mow only in dry conditions, if possible.

- Be aware of a potential fire hazard in very dry conditions, follow all local fire warnings, and keep the machine free of dry grass and leaf debris.
- If the finished lawn appearance is unsatisfactory, try 1 or more of the following:
 - Replace the blade or have it sharpened.
 - Walk at a slower pace while mowing.
 - Raise the cutting height on your machine.
 - Cut the grass more frequently.
 - Overlap cutting swaths instead of cutting a full swath with each pass.

Cutting Leaves

- After cutting the lawn, ensure that half of the lawn shows through the cut leaf cover. You may need to make more than a single pass over the leaves.
- Mowing grass over 15 cm (6 inches) in length is not recommended. If the leaf cover is too thick, the machine may plug and cause the engine to stall.
- Slow down your mowing speed if the machine does not cut the leaves finely enough.

After Operation

After Operating Safety

General Safety

- Clean grass and debris from the machine to help prevent fires. Clean up oil or fuel spills.
- Allow the engine to cool before storing the machine in any enclosure.
- Never store the machine or fuel container where there is an open flame, spark, or pilot light, such as on a water heater or on other appliances.

Hauling Safety

- Use care when loading or unloading the machine.
- Secure the machine.
- Use care when loading and unloading the machine to avoid sharp edges.

Cleaning the Machine

Service Interval: Before each use or daily

After each use

⚠ WARNING

The machine may dislodge material from under the machine housing.

- **Wear eye protection.**
 - **Stay in the operating position (behind the handle).**
 - **Do not allow bystanders in the area.**
1. Tip the machine on its side with the dipstick down.
 2. Use a brush or compressed air to remove grass and debris from the exhaust guard, the top cowl, and the surrounding deck areas.

Maintenance

Recommended Maintenance Schedule(s)

Maintenance Service Interval	Maintenance Procedure
Before each use or daily	<ul style="list-style-type: none">• Ensure that the engine shuts off within 3 seconds after releasing the operator-presence control.• Clean grass clippings and dirt from the entire machine.
After each use	<ul style="list-style-type: none">• Clean grass clippings and dirt from the entire machine.
Before storage	<ul style="list-style-type: none">• Empty the fuel tank before repairs as directed and before annual storage.• Clean the cooling system; remove grass clippings, debris, or dirt from the engine air cooling fins and starter. Clean the system more frequently in dirty or high-chaff conditions.
Yearly	<ul style="list-style-type: none">• Service the air filter; service it more frequently in dusty operating conditions.• Change the engine oil.• Service the spark plug and replace it if necessary.• Replace the blade or have it sharpened (more frequently if the edge dulls quickly).

Maintenance Safety

- Disconnect the spark-plug wire from the spark plug before performing any maintenance procedure.
- Wear gloves and eye protection when servicing the machine.
- The blade is sharp; contacting the blade can result in serious personal injury. Wear gloves when servicing the blade.
- Never tamper with safety devices. Check their proper operation regularly.
- Tipping the machine may cause the fuel to leak. Fuel is flammable and explosive, and can cause personal injury. Run the engine dry or remove the fuel with a hand pump; never siphon the fuel.
- To ensure optimum performance and continued safety certification of the machine, use only genuine Toro replacement parts and accessories. Replacement parts and accessories made by other manufacturers could be dangerous, and such use could void the product warranty.

Preparing for Maintenance

⚠ WARNING

Tipping the machine may cause the fuel to leak. Fuel is flammable, explosive and can cause personal injury.

Run the engine dry or remove the fuel with a hand pump; never siphon.

1. Shut off the engine and wait for all moving parts to stop.
2. Disconnect the spark-plug wire from the spark plug (Figure 19) before performing any maintenance procedure.

Important: Always tip the machine onto its side, with the dipstick down. If the machine is tipped in another direction, oil may fill the valve train, requiring at least 30 minutes to drain.

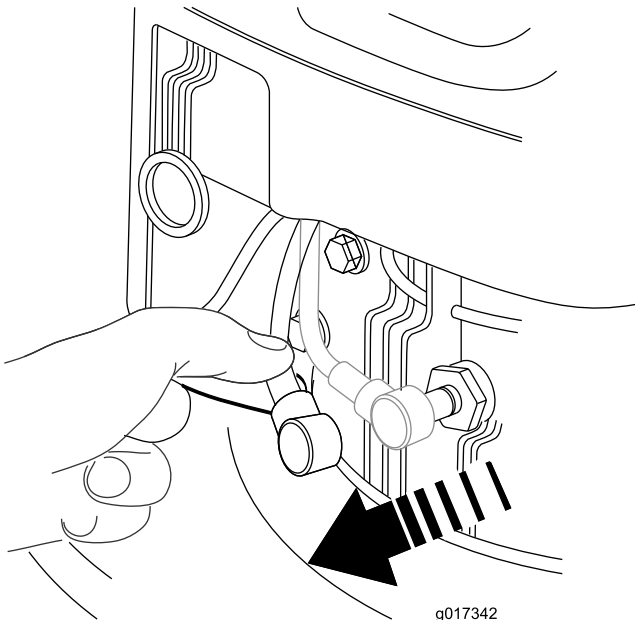

Figure 19

1. Spark-plug wire
-
3. After performing the maintenance procedure(s), connect the spark-plug wire to the spark plug.

Servicing the Air Filter

Service Interval: Yearly

1. Press down on the latch tabs on top of the air-filter cover (Figure 20).

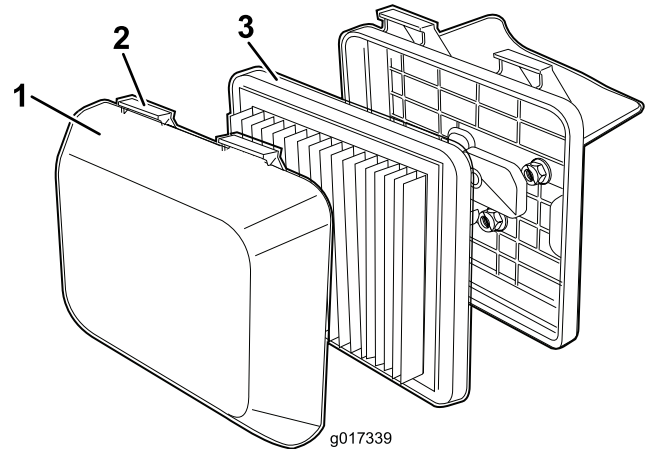

Figure 20

1. Cover
 2. Latch tabs
 3. Filter
-
2. Open the cover.
 3. Remove the air-filter elements (Figure 20).
 4. Inspect the air filter and replace it if it is damaged or excessively dirty.
 5. Inspect the paper air filter.
 - A. If the filter is damaged or is wet with oil or fuel, replace it.
 - B. If the filter is dirty, tap it on a hard surface several times or blow compressed air less than 207 kPa (30 psi) through the side of the filter that faces the engine.
- Note:** Do not brush the dirt off the filter; brushing forces dirt into the fibers.
6. Remove dirt from the air-filter body and cover using a moist rag.
- Important:** Do not wipe dirt into the air duct.
7. Insert the air-filter elements into the air-filter body.
 8. Install the cover.

Changing the Engine Oil

Service Interval: Yearly

Note: Run the engine a few minutes before changing the oil to warm it. Warm oil flows better and carries more contaminants.

Engine Oil Specifications

Engine oil capacity	0.59 L (20 fl oz)
Oil viscosity	SAE 10W-30 multigrade mineral oil
API service classification	SJ or higher

1. Ensure that the fuel tank contains little or no fuel so that the fuel does not leak when you tip the engine onto its side.
2. Refer to [Checking the Engine-Oil Level \(page 9\)](#).
3. Remove the dipstick by rotating the cap counterclockwise and pulling it out ([Figure 21](#)).

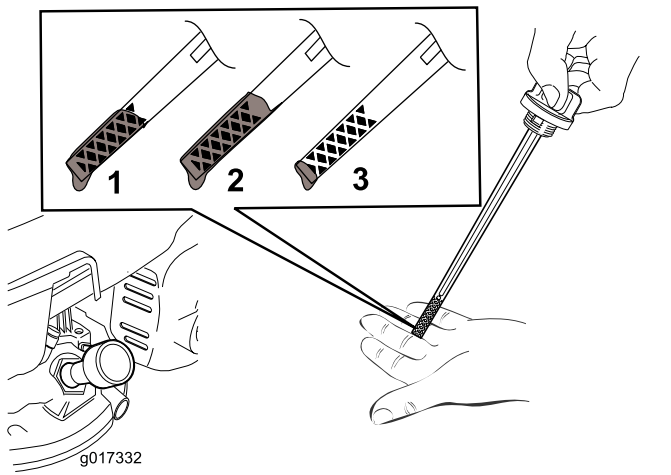

Figure 21

1. Full
2. High
3. Low

4. Tip the machine onto its side (so that the air filter is up) to drain the used oil from the oil-fill tube.
5. After draining the used oil, return the machine to the operating position.
6. Carefully pour about 3/4 of the engine capacity of oil into the oil-fill tube.
7. Wait 3 minutes for the oil to settle in the engine.
8. Wipe the dipstick clean with a clean cloth.
9. Insert the dipstick into the oil-fill tube, **but do not screw it in**, then remove the dipstick.
10. Read the oil level on the dipstick ([Figure 21](#)).
 - If the oil level on the dipstick is too low, carefully pour a small amount of oil into the

oil-fill tube, wait 3 minutes, and repeat steps [8](#) through [10](#) until the oil level on the dipstick is correct.

- If the oil level on the dipstick is too high, drain the excess oil until the oil level on the dipstick is correct.

Important: If the oil level in the engine is too low or too high and you run the engine, you may damage the engine.

11. Install the dipstick into the oil-fill tube securely.
12. Recycle the used oil properly.

Servicing the Spark Plug

Service Interval: Yearly—Service the spark plug and replace it if necessary.

Use a Toro spark plug; contact an Authorized Service Dealer.

1. Shut off the engine and wait for all moving parts to stop.
2. Disconnect the wire from the spark plug ([Figure 19](#)).
3. Clean around the spark plug.
4. Remove the spark plug from the cylinder head.

Important: Replace a cracked, fouled, or dirty spark plug. Do not clean the electrodes because grit entering the cylinder can damage the engine.

5. Set the gap on the plug to 0.76 mm (0.030 inch) as shown in [Figure 22](#).

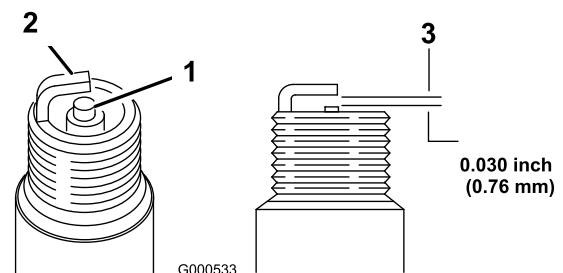

Figure 22

1. Center-electrode insulator
2. Side electrode
3. Air gap (not to scale)

6. Install the spark plug.
7. Torque the plug to 27 to 30 N·m (20 to 22 ft·lb).
8. Connect the wire to the spark plug.

Replacing the Blade

Service Interval: Yearly

Important: You will need a torque wrench to install the blade properly. If you do not have a torque wrench or are uncomfortable performing this procedure, contact an Authorized Service Dealer.

Examine the blade whenever you run out of fuel. If the blade is damaged or cracked, replace it immediately. If the blade edge is dull or nicked, have it sharpened and balanced, or replace it.

⚠ WARNING

The blade is sharp; contacting the blade can result in serious personal injury.

- Disconnect the wire from the spark plug.
 - Wear gloves when servicing the blade.
1. Refer to [Preparing for Maintenance \(page 16\)](#).
 2. Tip the machine onto its side, with the dipstick down.
 3. Use a block of wood to hold the blade steady.

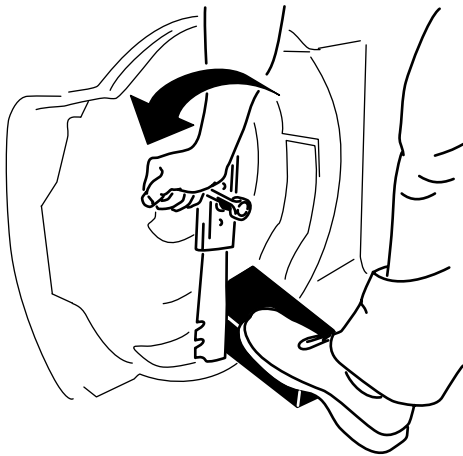

Figure 23

g209201

4. Remove the blade (turn the blade bolt counterclockwise), saving all the mounting hardware.
 5. Install the new blade (turn the blade bolt clockwise) and all mounting hardware.
- Important:** Position the curved ends of the blade to point toward the machine housing.
6. Use a torque wrench to tighten the blade bolt to 25 N·m (18 ft-lb).

Important: While holding the blade with a block of wood, put your weight behind

the ratchet or wrench and tighten the bolt securely. This bolt is very difficult to overtighten.

Storage

Store the machine in a cool, clean, dry place.

Preparing the Machine for Storage

⚠ WARNING

Fuel vapors can explode.

- Do not store fuel more than 30 days.
 - Do not store the machine in an enclosure near an open flame.
 - Allow the engine to cool before storing it.
1. On the last refueling of the year, add fuel stabilizer to the fuel as directed by the engine manufacturer.
 2. Run the machine until the engine shuts off from running out of fuel.
 3. Prime the engine and start it again.
 4. Allow the engine to run until it shuts off. When you can no longer start the engine, it is sufficiently dry.
 5. Disconnect the wire from the spark plug.
 6. Remove the spark plug, add 30 ml (1 fl oz) of oil through the spark-plug hole, and pull the starter rope **slowly** several times to distribute oil throughout the cylinder to prevent cylinder corrosion during the off-season.
 7. Install the spark plug and tighten it with a torque wrench to 20 N·m (15 ft-lb).
 8. Tighten all nuts, bolts, and screws.

Troubleshooting

Problem	Possible Cause	Corrective Action
The engine does not start.	<ol style="list-style-type: none"> 1. The wire is not connected to the spark plug. 2. The hole in the fuel-cap vent is plugged. 3. The spark plug is pitted, fouled, or the gap is incorrect. 4. The fuel tank is empty or the fuel system contains stale fuel. 	<ol style="list-style-type: none"> 1. Connect the wire to the spark plug. 2. Clean the hole in the fuel-cap vent or replace the fuel cap. 3. Check the spark plug and adjust the gap if necessary. Replace the spark plug if it is pitted, fouled, or cracked. 4. Drain and/or fill the fuel tank with fresh fuel. If the problem persists, contact an Authorized Service Dealer.
The engine starts hard or loses power.	<ol style="list-style-type: none"> 1. The hole in the fuel-cap vent is plugged. 2. The air filter element is dirty and is restricting the air flow. 3. The underside of the machine housing contains clippings and debris. 4. The spark plug is pitted, fouled, or the gap is incorrect. 5. The engine oil-level is too low, too high, or excessively dirty. 6. The fuel tank contains stale fuel. 	<ol style="list-style-type: none"> 1. Clean the hole in the fuel-cap vent or replace the fuel cap. 2. Clean the air filter pre-cleaner and/or replace the paper air filter. 3. Clean under the machine housing. 4. Check the spark plug and adjust the gap if necessary. Replace the spark plug if it is pitted, fouled, or cracked. 5. Check the engine oil. Change the oil if it is dirty; add or drain the oil to adjust the oil level to the Full mark on the dipstick. 6. Drain and fill the fuel tank with fresh fuel.
The engine runs rough.	<ol style="list-style-type: none"> 1. The wire is not connected to the spark plug. 2. The spark plug is pitted, fouled, or the gap is incorrect. 3. The air filter element is dirty and is restricting the air flow. 	<ol style="list-style-type: none"> 1. Connect the wire to the spark plug. 2. Check the spark plug and adjust the gap if necessary. Replace the spark plug if it is pitted, fouled, or cracked. 3. Clean the air filter pre-cleaner and/or replace the paper air filter.
The machine or engine vibrates excessively.	<ol style="list-style-type: none"> 1. The underside of the machine housing contains clippings and debris. 2. The engine mounting bolts are loose. 3. The blade mounting bolt loose. 4. The blade is bent or is out of balance. 	<ol style="list-style-type: none"> 1. Clean under the machine housing. 2. Tighten the engine mounting bolts. 3. Tighten the blade mounting bolt. 4. Balance the blade. If the blade is bent, replace it.
There is an uneven cutting pattern.	<ol style="list-style-type: none"> 1. You are mowing in the same pattern repeatedly. 2. The underside of the machine housing contains clippings and debris. 3. The blade is dull. 	<ol style="list-style-type: none"> 1. Change the mowing pattern. 2. Clean under the machine housing. 3. Sharpen and balance the blade.

Notes:

Notes:

California Proposition 65 Warning Information

What is this warning?

You may see a product for sale that has a warning label like the following:



WARNING: Cancer and Reproductive Harm—www.p65Warnings.ca.gov.

What is Prop 65?

Prop 65 applies to any company operating in California, selling products in California, or manufacturing products that may be sold in or brought into California. It mandates that the Governor of California maintain and publish a list of chemicals known to cause cancer, birth defects, and/or other reproductive harm. The list, which is updated annually, includes hundreds of chemicals found in many everyday items. The purpose of Prop 65 is to inform the public about exposure to these chemicals.

Prop 65 does not ban the sale of products containing these chemicals but instead requires warnings on any product, product packaging, or literature with the product. Moreover, a Prop 65 warning does not mean that a product is in violation of any product safety standards or requirements. In fact, the California government has clarified that a Prop 65 warning "is not the same as a regulatory decision that a product is 'safe' or 'unsafe.'" Many of these chemicals have been used in everyday products for years without documented harm. For more information, go to <https://oag.ca.gov/prop65/faqs-view-all>.

A Prop 65 warning means that a company has either (1) evaluated the exposure and has concluded that it exceeds the "no significant risk level"; or (2) has chosen to provide a warning based on its understanding about the presence of a listed chemical without attempting to evaluate the exposure.

Does this law apply everywhere?

Prop 65 warnings are required under California law only. These warnings are seen throughout California in a wide range of settings, including but not limited to restaurants, grocery stores, hotels, schools, and hospitals, and on a wide variety of products. Additionally, some online and mail order retailers provide Prop 65 warnings on their websites or in catalogs.

How do the California warnings compare to federal limits?

Prop 65 standards are often more stringent than federal and international standards. There are various substances that require a Prop 65 warning at levels that are far lower than federal action limits. For example, the Prop 65 standard for warnings for lead is 0.5 µg/day, which is well below the federal and international standards.

Why don't all similar products carry the warning?

- Products sold in California require Prop 65 labelling while similar products sold elsewhere do not.
- A company involved in a Prop 65 lawsuit reaching a settlement may be required to use Prop 65 warnings for its products, but other companies making similar products may have no such requirement.
- The enforcement of Prop 65 is inconsistent.
- Companies may elect not to provide warnings because they conclude that they are not required to do so under Prop 65; a lack of warnings for a product does not mean that the product is free of listed chemicals at similar levels.

Why does Toro include this warning?

Toro has chosen to provide consumers with as much information as possible so that they can make informed decisions about the products they buy and use. Toro provides warnings in certain cases based on its knowledge of the presence of one or more listed chemicals without evaluating the level of exposure, as not all the listed chemicals provide exposure limit requirements. While the exposure from Toro products may be negligible or well within the "no significant risk" range, out of an abundance of caution, Toro has elected to provide the Prop 65 warnings. Moreover, if Toro does not provide these warnings, it could be sued by the State of California or by private parties seeking to enforce Prop 65 and subject to substantial penalties.



The Toro Warranty

A Two-Year Limited Warranty

Conditions and Products Covered

The Toro Company and its affiliate, Toro Warranty Company, pursuant to an agreement between them, jointly warrant your Toro Commercial product ("Product") to be free from defects in materials or workmanship for two years or 1500 operational hours*, whichever occurs first. This warranty is applicable to all products with the exception of Aerators (refer to separate warranty statements for these products). Where a warrantable condition exists, we will repair the Product at no cost to you including diagnostics, labor, parts, and transportation. This warranty begins on the date the Product is delivered to the original retail purchaser.

* Product equipped with an hour meter.

Instructions for Obtaining Warranty Service

You are responsible for notifying the Commercial Products Distributor or Authorized Commercial Products Dealer from whom you purchased the Product as soon as you believe a warrantable condition exists. If you need help locating a Commercial Products Distributor or Authorized Dealer, or if you have questions regarding your warranty rights or responsibilities, you may contact us at:

Toro Commercial Products Service Department
Toro Warranty Company
8111 Lyndale Avenue South
Bloomington, MN 55420-1196
952-888-8801 or 800-952-2740
E-mail: commercial.warranty@toro.com

Owner Responsibilities

As the Product owner, you are responsible for required maintenance and adjustments stated in your *Operator's Manual*. Failure to perform required maintenance and adjustments can be grounds for disallowing a warranty claim.

Items and Conditions Not Covered

Not all product failures or malfunctions that occur during the warranty period are defects in materials or workmanship. This warranty does not cover the following:

- Product failures which result from the use of non-Toro replacement parts, or from installation and use of add-on, or modified non-Toro branded accessories and products. A separate warranty may be provided by the manufacturer of these items.
- Product failures which result from failure to perform recommended maintenance and/or adjustments. Failure to properly maintain your Toro product per the Recommended Maintenance listed in the *Operator's Manual* can result in claims for warranty being denied.
- Product failures which result from operating the Product in an abusive, negligent, or reckless manner.
- Parts subject to consumption through use unless found to be defective. Examples of parts which are consumed, or used up, during normal Product operation include, but are not limited to, brake pads and linings, clutch linings, blades, reels, rollers and bearings (sealed or greasable), bed knives, spark plugs, castor wheels and bearings, tires, filters, belts, and certain sprayer components such as diaphragms, nozzles, and check valves, etc.
- Failures caused by outside influence. Conditions considered to be outside influence include, but are not limited to, weather, storage practices, contamination, use of unapproved fuels, coolants, lubricants, additives, fertilizers, water, or chemicals, etc.
- Failure or performance issues due to the use of fuels (e.g. gasoline, diesel, or biodiesel) that do not conform to their respective industry standards.

Countries Other than the United States or Canada

Customers who have purchased Toro products exported from the United States or Canada should contact their Toro Distributor (Dealer) to obtain guarantee policies for your country, province, or state. If for any reason you are dissatisfied with your Distributor's service or have difficulty obtaining guarantee information, contact the Toro importer.

- Normal noise, vibration, wear and tear, and deterioration.
- Normal "wear and tear" includes, but is not limited to, damage to seats due to wear or abrasion, worn painted surfaces, scratched decals or windows, etc.

Parts

Parts scheduled for replacement as required maintenance are warranted for the period of time up to the scheduled replacement time for that part. Parts replaced under this warranty are covered for the duration of the original product warranty and become the property of Toro. Toro will make the final decision whether to repair any existing part or assembly or replace it. Toro may use remanufactured parts for warranty repairs.

Deep Cycle and Lithium-Ion Battery Warranty:

Deep cycle and Lithium-Ion batteries have a specified total number of kilowatt-hours they can deliver during their lifetime. Operating, recharging, and maintenance techniques can extend or reduce total battery life. As the batteries in this product are consumed, the amount of useful work between charging intervals will slowly decrease until the battery is completely worn out. Replacement of worn out batteries, due to normal consumption, is the responsibility of the product owner. Battery replacement may be required during the normal product warranty period at owner's expense. Note: (Lithium-Ion battery only): A Lithium-Ion battery has a part only prorated warranty beginning year 3 through year 5 based on the time in service and kilowatt hours used. Refer to the *Operator's Manual* for additional information.

Maintenance is at Owner's Expense

Engine tune-up, lubrication, cleaning and polishing, replacement of filters, coolant, and completing recommended maintenance are some of the normal services Toro products require that are at the owner's expense.

General Conditions

Repair by an Authorized Toro Distributor or Dealer is your sole remedy under this warranty.

Neither The Toro Company nor Toro Warranty Company is liable for indirect, incidental or consequential damages in connection with the use of the Toro Products covered by this warranty, including any cost or expense of providing substitute equipment or service during reasonable periods of malfunction or non-use pending completion of repairs under this warranty. Except for the Emissions warranty referenced below, if applicable, there is no other express warranty. All implied warranties of merchantability and fitness for use are limited to the duration of this express warranty.

Some states do not allow exclusions of incidental or consequential damages, or limitations on how long an implied warranty lasts, so the above exclusions and limitations may not apply to you. This warranty gives you specific legal rights, and you may also have other rights which vary from state to state.

Note regarding engine warranty:

The Emissions Control System on your Product may be covered by a separate warranty meeting requirements established by the U.S. Environmental Protection Agency (EPA) and/or the California Air Resources Board (CARB). The hour limitations set forth above do not apply to the Emissions Control System Warranty. Refer to the Engine Emission Control Warranty Statement supplied with your product or contained in the engine manufacturer's documentation for details