



Count on it.

Parts Catalog

22in Recycler®

Lawn Mower

Model No. 20378—Serial No. 404320000 and Up



Ordering Replacement Parts

To order replacement parts, please supply the part number, the quantity, and the description of each part desired.

Understanding Reference Numbers

Each identified part in an illustration has a reference number. The reference number for a part also appears in the parts list, along with other information about the part.

This catalog uses two special reference number formats, one to indicate parts in a service assembly and another to indicate the quantity of a given part in an illustration.

Service Assembly Reference Numbers

Parts in service assemblies have reference numbers in the form a:b. The a represents the reference number of the entire service assembly and the b represents a sequential number unique to each part within the service assembly.

For example, a wheel assembly might be identified by reference number 6, the tire by 6:1, the valve by 6:2, and the wheel by 6:3. When you order the assembly identified by reference number 6, you receive all parts identified by reference numbers 6:1, 6:2, and 6:3. However, you may also order any part individually. Reference numbers of this type appear in illustration and in parts lists.

Reference Numbers Indicating Quantity

In an illustration, if a reference number indicates more than one part, the reference number has the form nX y. The n represents the quantity of the part, the X is the multiplication symbol, and the y represents the reference number.

For example, in an illustration, the reference number 2X 37 means that two of the parts identified by reference number 37 are indicated.

Contents

Housing Assembly	4
Rear Bag Assembly	6
Engine and Blade Assembly	8
Front Wheel and Height-of-Cut Assembly	10
Rear Wheel and Height-of-Cut Assembly	12
Handle Assembly	14
Attachments and Accessories	16

Housing Assembly

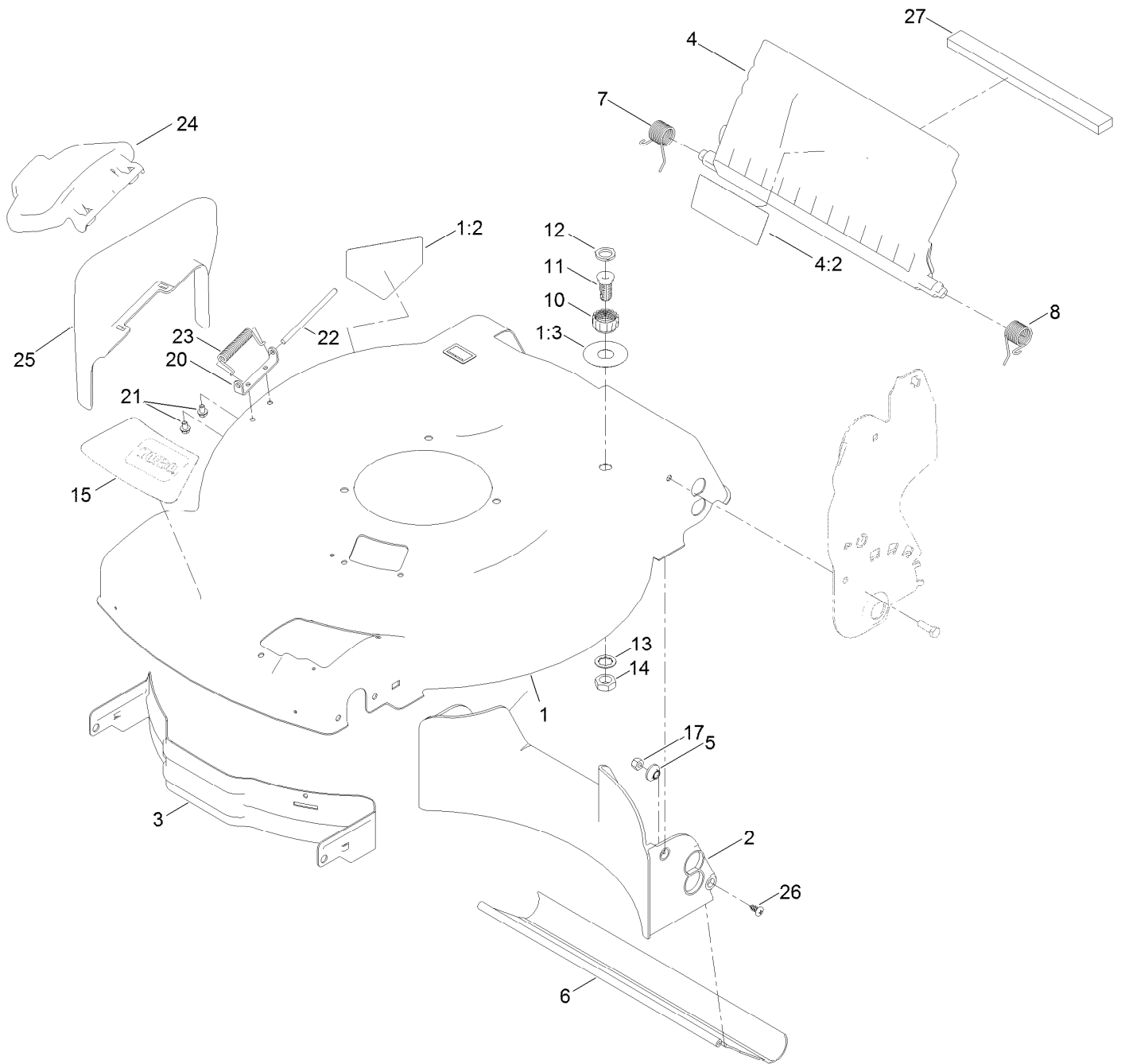

Housing Assembly (continued)

<i>Ref.</i>	<i>Part Number</i>	<i>Qty.</i>	<i>Description</i>	<i>Ref.</i>	<i>Part Number</i>	<i>Qty.</i>	<i>Description</i>
1	136-7052	1	Housing ASM	12	112-6438	1	Washer-Seal, Washout Port
1:2	94-8072	1	Decal-Danger	13	3254-5	1	Washer-Lock
1:3	137-9196	1	Decal-Quick Wash	14	3218-6	1	Nut-Jam
2	120-5218	1	Baffle-Rear	15	131-4540	1	Decal-Deck, Recycler
3	114-7963-01	1	Baffle-Front	17	3296-29	2	Nut-Lock, NI
4	136-7003	1	Rear Deflector ASM	20	112-6416	1	Bracket-Cover
4:2	131-4514	1	Decal-Warning	21	99-8445	2	Screw-HWH
5	117-5991	2	Washer-Stepped, Baffle	22	99-5291	1	Rod-Cover
6	115-8420	1	Shield-Trailing	23	99-5293	1	Spring-Torsion
7	114-7924	1	Spring-Torsion	24	115-8449	1	Deflector-Side
8	115-2859	1	Spring-Torsion	25	115-8447	1	Chute-Discharge, Side
10	112-6401	1	Coupling-Hose, Washout Port	26	117-1092	2	Screw-PTH
11	112-6400	1	Port-Washout	27	117-5924	1	Foam-Seal

Rear Bag Assembly

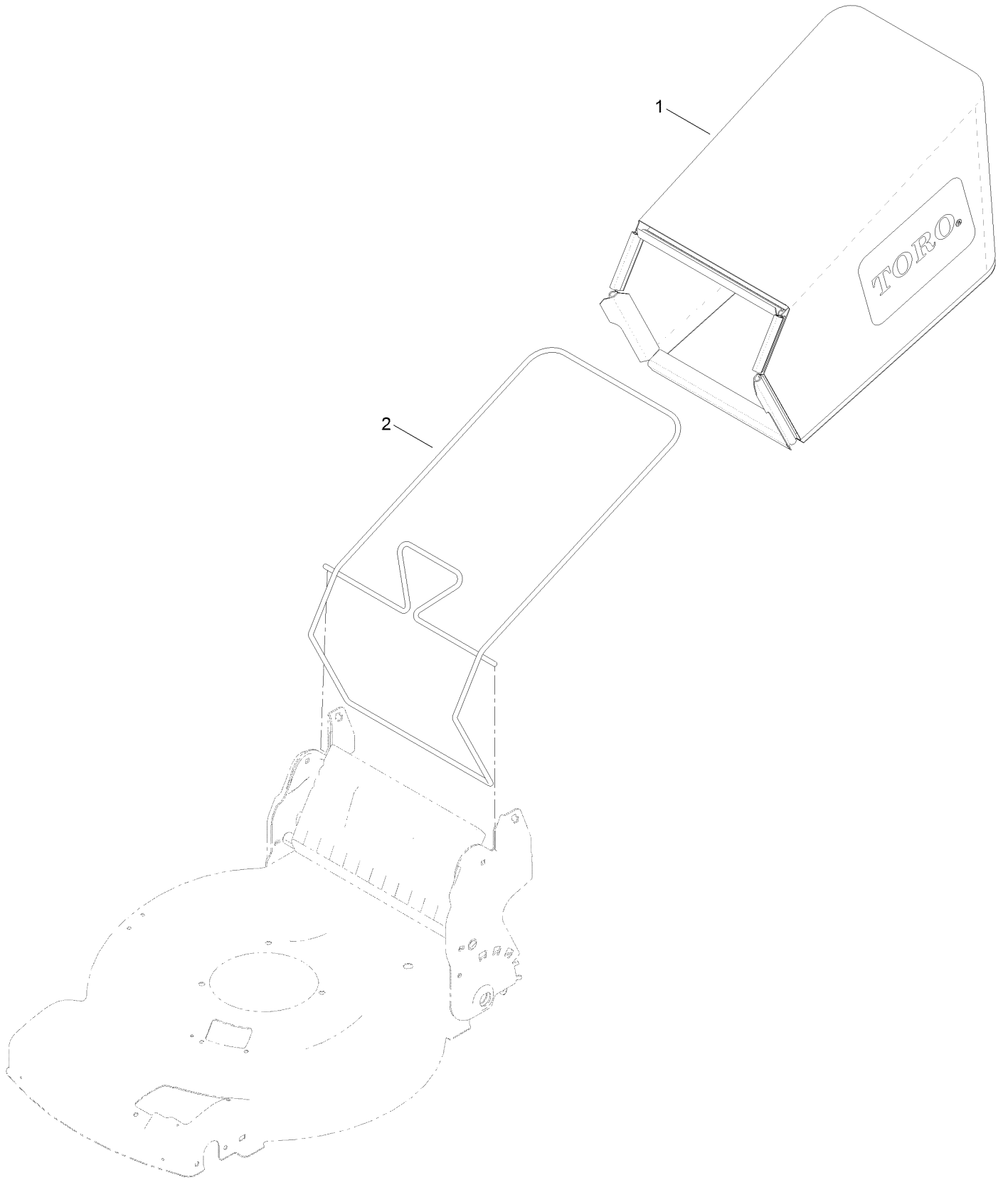

Rear Bag Assembly (continued)

<i>Ref.</i>	<i>Part Number</i>	<i>Qty.</i>	<i>Description</i>
1	115-4664	1	Grass Bag ASM
2	132-4483-03	1	Frame-Bag

Engine and Blade Assembly

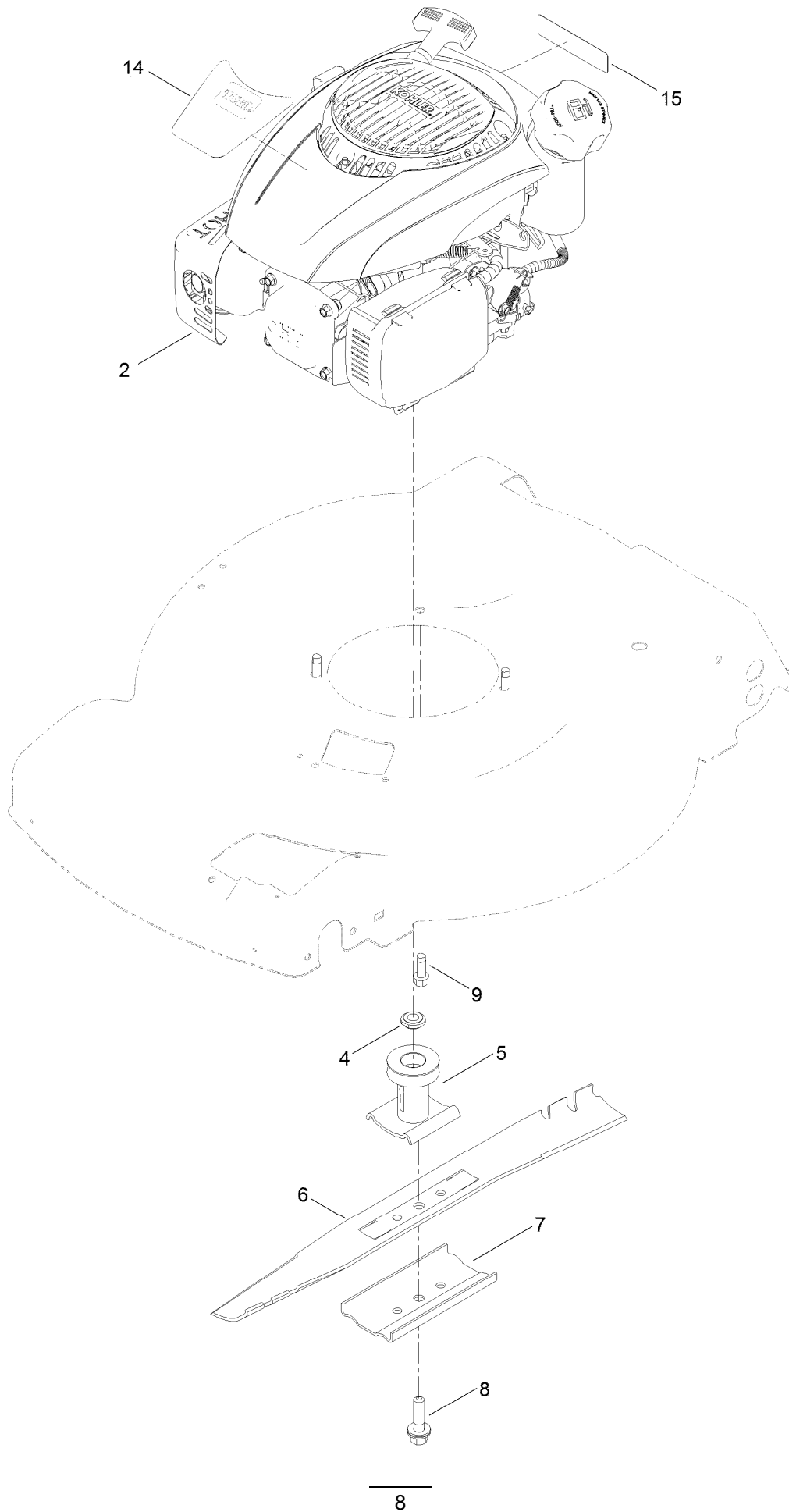

Engine and Blade Assembly (continued)

<i>Ref.</i>	<i>Part Number</i>	<i>Qty.</i>	<i>Description</i>	<i>Ref.</i>	<i>Part Number</i>	<i>Qty.</i>	<i>Description</i>
2		1	Engine-Kohler Xtx675-3013 ●■	7	108-3766-03	1	Support-Blade
4	106-3999	1	Spacer-Driver	8	125-2466	1	Bolt-Blade
5	106-3987	1	Driver-Blade	9	95-1726	3	Screw-Taptite
6	131-4547-03	1	Blade-22 Inch	14	133-8192	1	Decal-Shroud
				15	133-8062	1	Decal-Arrestor, Spark

● Not serviced separately

■ Obtain parts from www.kohlerplus.com

Front Wheel and Height-of-Cut Assembly

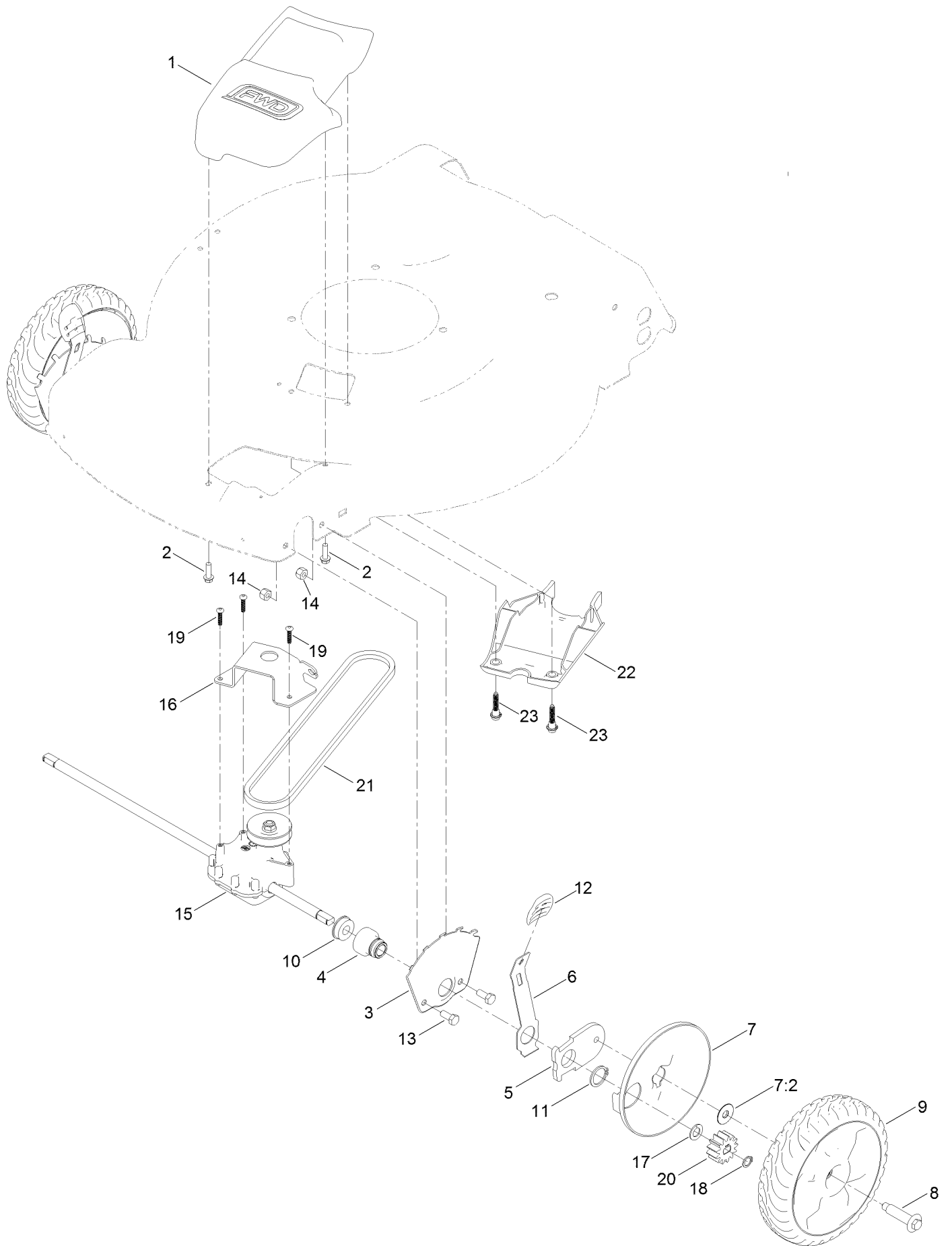

Front Wheel and Height-of-Cut Assembly (continued)

<i>Ref.</i>	<i>Part Number</i>	<i>Qty.</i>	<i>Description</i>	<i>Ref.</i>	<i>Part Number</i>	<i>Qty.</i>	<i>Description</i>
1	136-5907	1	Cover-Belt	12	105-3042	2	Knob-Lever, HOC
2	46-8091	2	Screw-HWH	13	322-3	4	Screw-HH
3	115-1956-03	2	Plate-HOC, Front	14	3296-29	4	Nut-Lock, NI
4	131-0836	2	Retainer-Bearing, HOC	15	137-4822	1	Transmission
5	137-9128	2	Arm-Pivot, Front	16	114-7978-03	1	Bracket-Transmission
6	105-1809	2	Arm-Spring	17	110-7191	2	Washer-Thrust
7	127-6840	2	Wheel Cover ASM	18	32151-61	2	Ring-Retaining
7:2	614426	1	Washer-Stepped	19	108-7476	3	Screw-Plastite
8	614650	2	Bolt-Shoulder	20	131-0896	2	Gear-Pinion, 13T
9	137-4832	2	8 In Wheel ASM	21	117-1018	1	V-Belt
10	104-8699	2	Bearing-Ball	22	136-5851	1	Cover-Belt, Front (Lower)
11	32151-36	2	Ring-Retaining	23	131-0837	2	Screw-Shoulder, HHF

Rear Wheel and Height-of-Cut Assembly

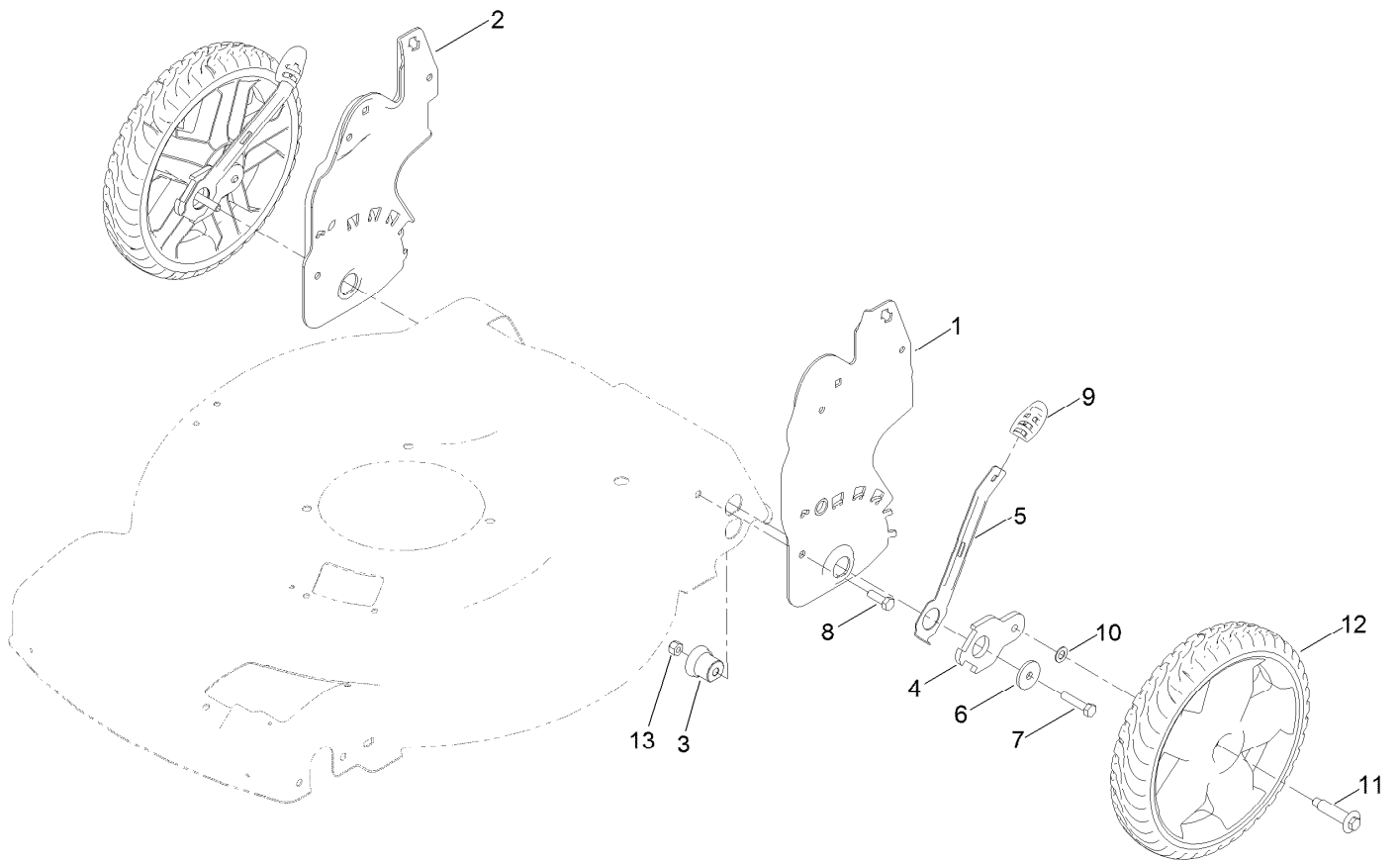

Rear Wheel and Height-of-Cut Assembly (continued)

<i>Ref.</i>	<i>Part Number</i>	<i>Qty.</i>	<i>Description</i>	<i>Ref.</i>	<i>Part Number</i>	<i>Qty.</i>	<i>Description</i>
1	132-4490-03	1	Plate-HOC, LH	8	322-5	2	Screw-HH
2	132-4491-03	1	Plate-HOC, RH	9	105-3042	2	Knob-Lever, HOC
3	131-0895	2	Bushing-Mount, HOC	10	40-1940	2	Washer
4	137-9129	2	Arm-Pivot, Rear	11	614650	2	Bolt-Shoulder
5	115-2899	2	Arm-Spring, Rear	12	137-4837	2	11In Wheel ASM
6	105-3048	2	Washer-Flat	13	3296-29	2	Nut-Lock, NI
7	322-7	2	Screw-HH				

Handle Assembly

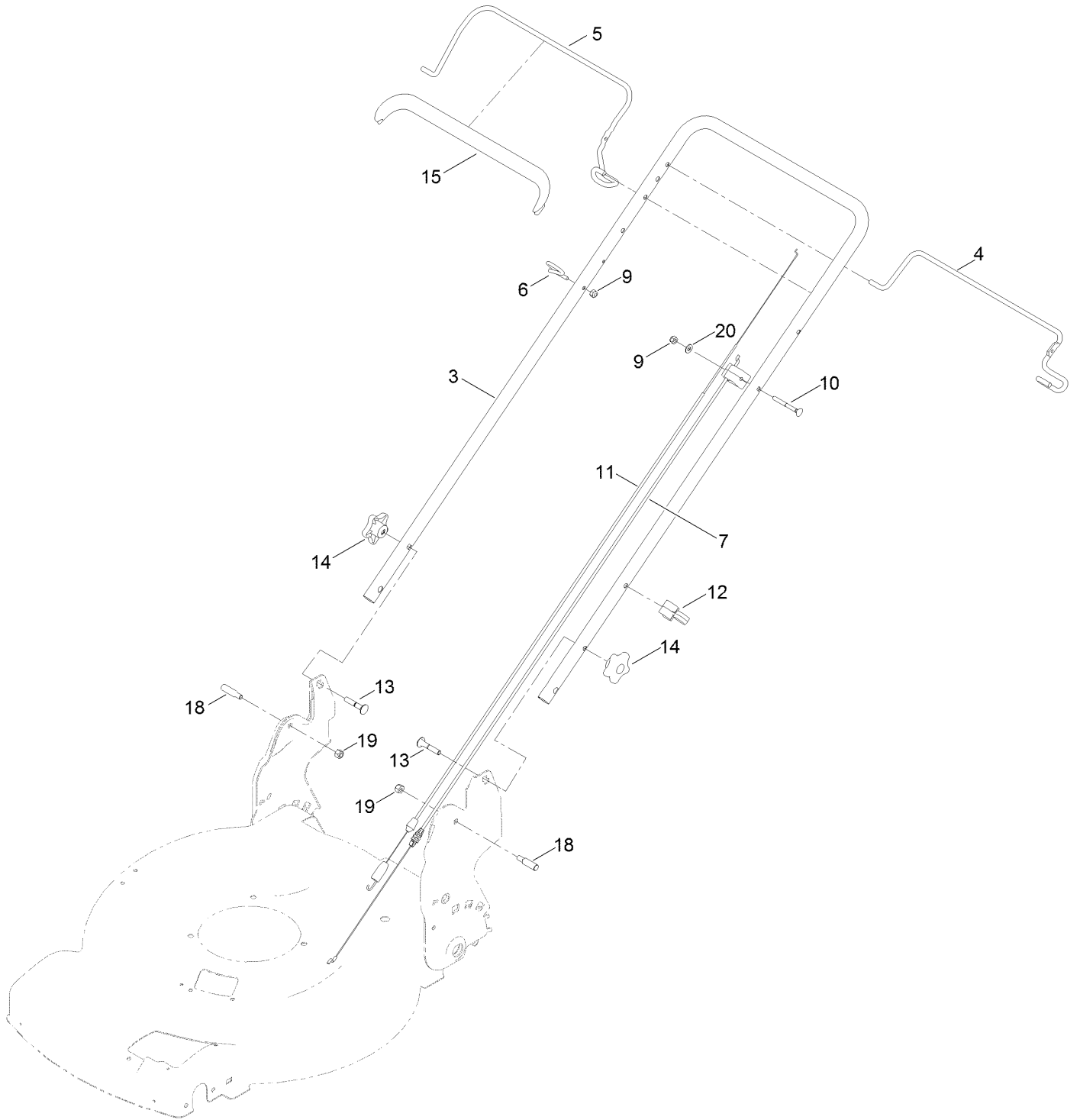

Handle Assembly (continued)

<i>Ref.</i>	<i>Part Number</i>	<i>Qty.</i>	<i>Description</i>	<i>Ref.</i>	<i>Part Number</i>	<i>Qty.</i>	<i>Description</i>
3	131-4598-05	1	Handle	12	114-7988	1	Guide-Cable
4	131-0835-03	1	Bail-Traction	13	131-9663	2	Screw-CARR
5	138-3269-03	1	Bail-Brake	14	117-5976	2	Knob-Handle
6	86-9671	1	Guide-Rope	15	127-6847	1	Cover-Bail
7	133-8109	1	Cable-Brake, HP	18	131-4591	2	Bolt-Shoulder
9	3296-73	2	Nut-Lock, NI	19	3296-29	2	Nut-Lock, NI
10	92-2270	1	Screw-Handle	20	3256-1	1	Washer-Flat
11	119-2379	1	Cable-Traction				

Attachments and Accessories

For 20378 22in Recycler Lawn Mower

Product Name	Model/Part
All Season Synthetic Oil (10W30, QT)	117-0066
Fuel Stabilizer .05 oz	130-2393
Engine Service Kit	130-8144
4-Cycle Fuel, Snow And Lawn 32oz Can	131-3823
Toro Premium Fuel Treatment 12 Oz Bottle	131-6572
Belt Cover Kit.....	136-9125
Wheel Asm, 11in.....	137-4837P
Lawn Striping Kit with 22in Roller.....	20601
Toro 4-Cycle SAE 30 Oil (32oz Bottle)	38903
Summer Oil-Case of 24 (20oz Bottles).....	38916
Replacement Drive Belt Kit, 22-inch 2009 and After Front-Wheel Drive Lawn Mower.....	38990
Bag-Walk Behind (Toro).....	490-7318
Lawnmower Cover.....	490-7462
Replacement Bag	59305
Replacement Bag and Frame Kit.....	59307
8in Gear Wheel ASM	59502
22 Inch Atomic Blade	59534P

Notes:

Notes:

Notes:



Count on it.