



**ProLine  
20 HP**

# **Traction Unit**

**Model No. 30611 – 990001 & Up**

---

## **Operator's Manual**

**IMPORTANT:** Read this manual carefully. It contains information about your safety and the safety of others. Also become familiar with the controls and their proper use before you operate the product.

# Introduction

Thank you for purchasing a Toro product.

All of us at Toro want you to be completely satisfied with your new product, so feel free to contact your local Authorized Service Dealer for help with service, genuine replacement parts, or other information you may require.

Whenever you contact your Authorized Service Dealer or the factory, always know the model and serial numbers of your product. These numbers will help the Service Dealer or Service Representative provide exact information about your specific product. You will find the model and serial number plate located in a unique place on the product as shown below.

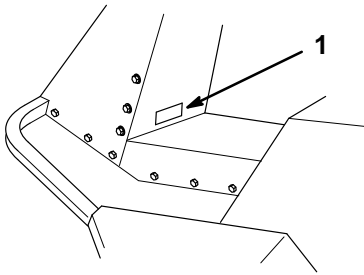

m-2196

1. Model and Serial Number Plate

For your convenience, write the product model and serial numbers in the space below.

|                         |
|-------------------------|
| <b>Model No:</b> _____  |
| <b>Serial No.</b> _____ |

Read this manual carefully to learn how to operate and maintain your product correctly. Reading this manual will help you and others avoid personal injury and damage to the product. Although we design, produce and market safe, state-of-the-art products, you are responsible for using the product properly and safely. You are also responsible for training persons, who you allow to use the product, about safe operation.

The warning system in this manual identifies potential hazards and has special safety messages that help you and others avoid personal injury, even death. DANGER, WARNING and CAUTION are signal words used to identify the level of hazard. However, regardless of the hazard, be extremely careful.

**DANGER** signals an extreme hazard that will cause serious injury or death if the recommended precautions are not followed.

**WARNING** signals a hazard that may cause serious injury or death if the recommended precautions are not followed.

**CAUTION** signals a hazard that may cause minor or moderate injury if the recommended precautions are not followed.

Two other words are also used to highlight information. “Important” calls attention to special mechanical information and “Note” emphasizes general information worthy of special attention.

The left and right side of the machine is determined from the normal operator’s position.

|   |
|---|
| <b>! WARNING: !</b>   |
| <b>The engine exhaust from this product contains chemicals known to the State of California to cause cancer, birth defects, or other reproductive harm.</b> |

**IMPORTANT: This engine is not equipped with a spark arrester muffler. It is a violation of California Public Resource Code Section 4442 to use or operate this engine on any forest-covered, brush-covered or grass-covered land. Other states or federal areas may have similar laws.**

# Contents

|   | <b>Page</b> |   | <b>Page</b> |
|---|-------------|---|-------------|
| Safety .....                                  | 2           | Maintenance .....                               | 20          |
| Safe Operation Practices for Ride-on (riding) |             | Service Interval Chart .....                    | 20          |
| Rotary Lawnmower Machines .....               | 2           | Belt Guard .....                                | 21          |
| Slope Chart .....                             | 5           | Air Cleaner .....                               | 21          |
| Symbols Glossary .....                        | 7           | Engine Oil .....                                | 23          |
| Symbols Glossary .....                        | 8           | Spark Plug .....                                | 25          |
| Symbols Glossary .....                        | 9           | Greasing and Lubrication .....                  | 26          |
| Gasoline and Oil .....                        | 10          | Brake .....                                     | 28          |
| Recommended Gasoline .....                    | 10          | Fuel Filter .....                               | 29          |
| Stabilizer/Conditioner .....                  | 11          | Tire Pressure .....                             | 29          |
| Filling the Fuel Tank .....                   | 11          | Cleaning the Cooling System .....               | 30          |
| Check Engine Oil Level .....                  | 11          | Adjust Belts .....                              | 30          |
| Set-up .....                                  | 12          | Replace Belts .....                             | 31          |
| Loose Parts .....                             | 12          | Adjust Lift Cylinder and Counterbalance Springs |             |
| Install Seat .....                            | 13          | 31  |             |
| Install Steering Wheel .....                  | 13          | Adjust Transmission Neutral .....               | 32          |
| Install Rear Weights .....                    | 13          | Adjust Electric Clutch .....                    | 33          |
| Activate the Battery .....                    | 14          | Check Hydraulic System Fluid .....              | 34          |
| Install the Battery .....                     | 15          | Change Hydraulic System Oil .....               | 34          |
| Check Engine Oil .....                        | 15          | Change Hydraulic Oil Filter .....               | 35          |
| Check Hydraulic System Fluid .....            | 15          | Adjust Steering .....                           | 35          |
| Operation .....                               | 16          | Hydraulic Schematic .....                       | 36          |
| Think Safety First .....                      | 16          | Change Front Axle Oil .....                     | 37          |
| Starting and Stopping                         |             | Battery .....                                   | 37          |
| the Engine .....                              | 16          | Wire Harness Service .....                      | 38          |
| Operating the Power Take Off (PTO) ....       | 17          | Wiring Diagram .....                            | 39          |
| Driving Forward or Backward .....             | 17          | Cleaning and Storage .....                      | 40          |
| Parking Brake .....                           | 18          | Troubleshooting .....                           | 42          |
| Implement Lift Lever .....                    | 18          |   |             |
| The Safety Interlock System .....             | 19          |   |             |
| Positioning the Seat .....                    | 19          |   |             |
| Pushing or Towing the Machine .....           | 19          |   |             |

# Safety

## Safe Operation Practices for Ride-on (riding) Rotary Lawnmower Machines

### Training

1. Read the instructions carefully. Be familiar with the controls and the proper use of the equipment.
2. Never allow children or people unfamiliar with these instructions to use the lawnmower. Local regulations may restrict the age of the operator.
3. Never mow while people, especially children, or pets are nearby.
4. Keep in mind that the operator or user is responsible for accidents or hazards occurring to other people or their property.
5. Do not carry passengers.
6. All drivers should seek and obtain professional and practical instruction. Such instruction should emphasize:
  - the need for care and concentration when working with ride-on machines;
  - control of a ride-on machine sliding on a slope will not be regained by the application of the brake. The main reasons for loss of control are:
    - insufficient wheel grip;
    - being driven too fast;
    - inadequate braking;
    - the type of machine is unsuitable for its task;
    - lack of awareness of the effects of ground conditions, especially slopes;
    - incorrect hitching and load distribution.

### Preparation

1. While mowing, always wear substantial footwear and long trousers. Do not operate the equipment when barefoot or wearing open sandals.
2. Thoroughly inspect the area where the equipment is to be used and remove all objects which may be thrown by the machine.
3. **WARNING** – Petrol is highly flammable.
  - Store fuel in containers specifically designed for this purpose.
  - Refuel outdoors only and do not smoke while refuelling.
  - Add fuel before starting the engine. Never remove the cap of the fuel tank or add petrol while the engine is running or when the engine is hot.
  - If petrol is spilled, do not attempt to start the engine but move the machine away from the area of spillage and avoid creating any source of ignition until petrol vapors have dissipated.
  - Replace all fuel tanks and container caps securely.
4. Replace faulty silencers.
5. Before using, always visually inspect to see that the blades, blade bolts and cutter assembly are not worn or damaged. Replace worn or damaged blades and bolts in sets to preserve balance.
6. On multi-bladed machines, take care as rotating one blade can cause other blades to rotate.

## Operation

1. Do not operate the engine in a confined space where dangerous carbon monoxide fumes can collect.
2. Mow only in daylight or in good artificial light.
3. Before attempting to start the engine, disengage all blade attachment clutches and shift into neutral.
4. Do not use on slopes of more than:
  - Never mow side hills over 5°
  - Never mow uphill over 10°
  - Never mow downhill over 15°

**Note:** Slope angle is calculated as in 5.4.2.3.2.
5. Remember there is no such thing as a “safe” slope. Travel on grass slopes requires particular care. To guard against overturning:
  - do not stop or start suddenly when going up or downhill;
  - engage clutch slowly, always keep machine in gear, especially when travelling downhill;
  - machine speeds should be kept low on slopes and during tight turns;
  - stay alert for bumps and hollows and other hidden hazards;
  - never mow across the face of the slope, unless the lawnmower is designed for this purpose.
6. Use care when pulling loads or using heavy equipment.
  - Use only approved drawbar hitch points.
  - Limit loads to those you can safely control.
  - Do not turn sharply. Use care when reversing.
  - Use counterweight(s) or wheel weights when suggested in the instruction handbook.
7. Watch out for traffic when crossing or near roadways.
8. Stop the blades rotating before crossing surfaces other than grass.
9. When using any attachments, never direct discharge of material toward bystanders nor allow anyone near the machine while in operation.
10. Never operate the lawnmower with defective guards, shields or without safety protective devices in place.
11. Do not change the engine governor settings or overspeed the engine. Operating the engine at excessive speeds may increase the hazard of personal injury.
12. Before leaving the operator’s position:
  - disengage the power take-off and lower the attachments;
  - change into neutral and set the parking brake;
  - stop the engine and remove the key.
13. Disengage drive to attachments, stop the engine, and disconnect the spark plug wire(s) or remove the ignition key
  - before cleaning blockages or unclogging chute;
  - before checking, cleaning or working on the lawnmower;
  - after striking a foreign object. Inspect the lawnmower for damage and make repairs before restarting and operating the equipment;
  - if the machine starts to vibrate abnormally (check immediately).
14. Disengage drive to attachments when transporting or not in use.

15. Stop the engine and disengage drive to attachment
  - before refuelling;
  - before removing the grass catcher;
  - before making height adjustment unless adjustment can be made from the operator's position.
16. Reduce the throttle setting during engine run-out and, if the engine is provided with a shut-off valve, turn the fuel off at the conclusion of mowing.

### **Maintenance and storage**

1. Keep all nuts, bolts and screws tight to be sure the equipment is in safe working condition.
2. Never store the equipment with petrol in the tank inside a building where fumes may reach an open flame or spark.
3. Allow the engine to cool before storing in any enclosure.
4. To reduce the fire hazard, keep the engine, silencer, battery compartment and petrol storage area free of grass, leaves, or excessive grease.
5. Check the grass catcher frequently for wear or deterioration.
6. Replace worn or damaged parts for safety.
7. If the fuel tank has to be drained, this should be done outdoors.
8. On multi-bladed machines, take care as rotating one blade can cause other blades to rotate.
9. When machine is to be parked, stored or left unattended, lower the cutting means unless a positive mechanical lock is used.

### **Sound Pressure**

This unit has an equivalent continuous A-weighted sound pressure at the operator ear of: 88 dB(A), based on measurements of identical machines per ANSI B71.5–1984 procedure.

### **Sound Power**

This unit has a power level of: 104 dB(A)/1pW, based on measurements of identical machines per Directive 84/538/EEC and amendments.

### **Vibration Level**

This unit has a maximum hand-arm vibration level of 6.1 m/s<sup>2</sup>, and whole body vibration level of 0.16 m/s<sup>2</sup>, based on measurements of identical machines per ISO 5349.

# Slope Chart

Read all safety instructions on pages 2-9.

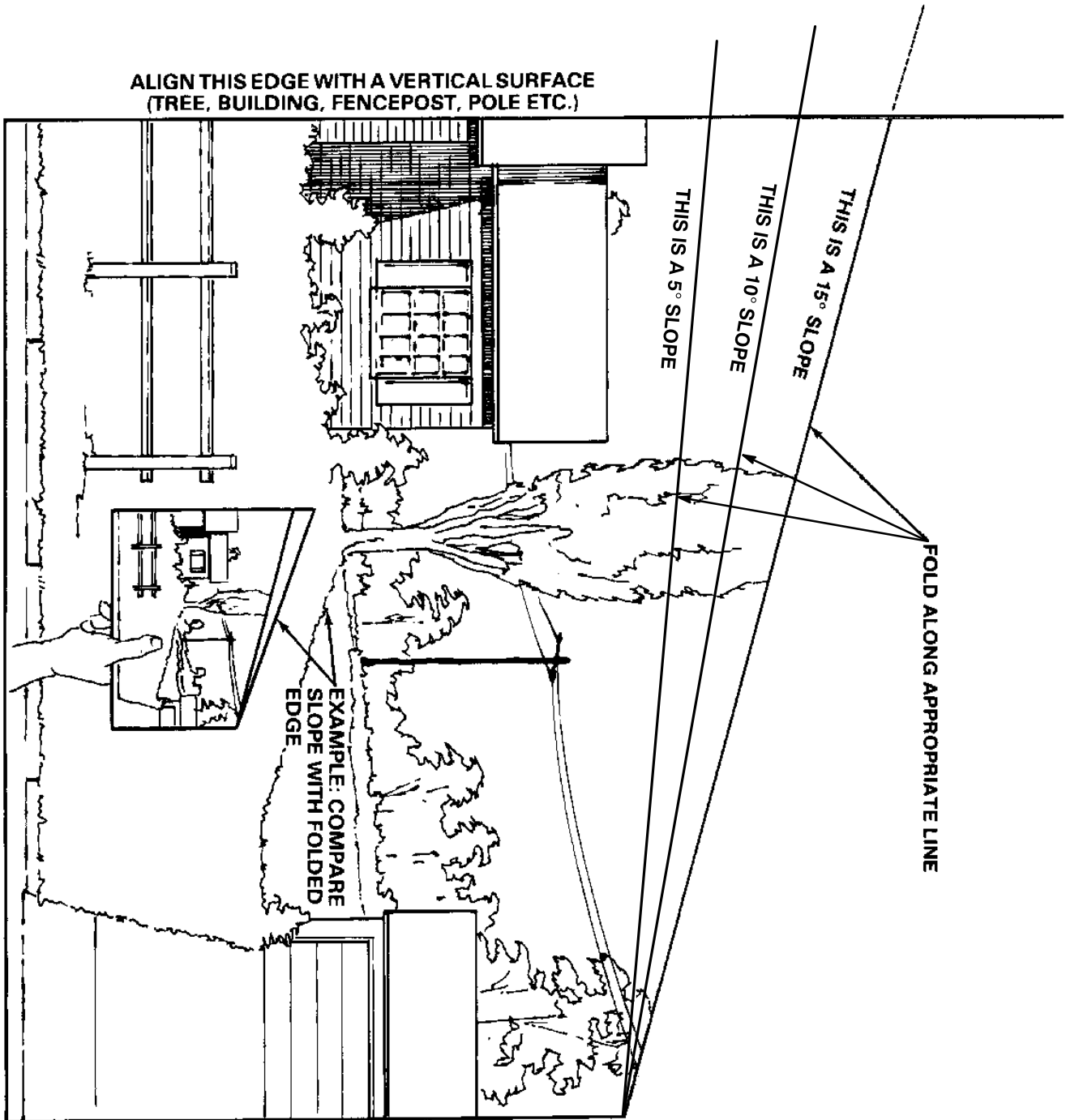



# Symbols Glossary

Safety alert triangle—symbol within triangle indicates a hazard



Fire, open light & smoking prohibited



Safety alert symbol



Fire or open flame



Read operator's manual



Explosion



Consult technical manual for proper service procedures



Do not dispose of lead battery in garbage



Shut off engine & remove key before performing maintenance or repair work

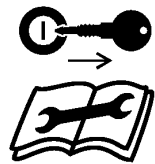

Stay a safe distance from the machine

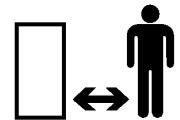

Caustic liquids, chemical burns to fingers or hand



Stay safe distance from machine

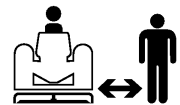

Caution, toxic risk



Stay safe distance from machine, riding mower

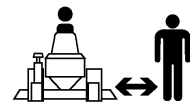

Eye protection must be worn



Stay safe distance from machine

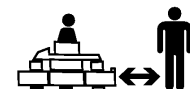

First aid, flush with water



Keep children away from battery



## Symbols Glossary

Do not open or remove safety shields while engine is running

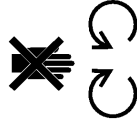

Stored energy hazard, kickback or upward motion



Thrown or flying objects, whole body exposure



Wait until all machine components have completely stopped before touching them



Thrown or flying objects, whole body exposure



Machine rollover, riding mower



Keep guards and safety shields in place

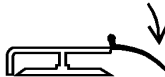

To operate machine on a slope, use with 16kg weight kit & operate with deck lowered



Severing of toes & fingers, rotary mower blade



Operating machine on a slope less than 10°, operate with deck lowered on downhill, riding mower

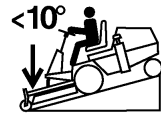

Cutting of fingers or hand



Disengage PTO, set parking brake, turn off engine and remove key before leaving operator's position



Cutting of foot



Hot surface, burns to fingers or hands



Blade cutting element-height adjustment















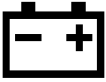

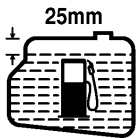



Severing of fingers or hand-engine fan

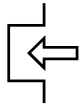

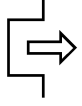
Blade retaining bolts must be Torqued to 115–149 N.m

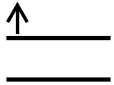

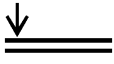
# Symbols Glossary

|                       |   |                      |   |
|-----------------------|---|----------------------|---|
| Fast                  |    | Engine Oil           |    |
| Slow                  |    | Battery              |    |
| Decreasing/Increasing |    | Gas Tank Level       |    |
| On/Run                |    | Lock                 |    |
| Off/stop              |    | Power take off (PTO) |  |
| Engine start          |   | Engage               |  |
| Engine stop           |  | Disengage            |  |
| Choke                 |  | Attachmant Raise     |  |
| Brake system          |  | Attachment Lower     |  |
| Parking brake         |  |                      |   |

# Gasoline and Oil

## Recommended Gasoline

Use UNLEADED Regular Gasoline suitable for automotive use (85 pump octane minimum). Leaded regular gasoline may be used if unleaded regular is not available.

**IMPORTANT:** Never use methanol, gasoline containing methanol, or gasohol containing more than 10% ethanol because the fuel system could be damaged. Do not mix oil with gasoline.

### DANGER

#### POTENTIAL HAZARD

- In certain conditions gasoline is extremely flammable and highly explosive.

#### WHAT CAN HAPPEN

- A fire or explosion from gasoline can burn you, others, and cause property damage.

#### HOW TO AVOID THE HAZARD

- Use a funnel and fill the fuel tank outdoors, in an open area, when the engine is cold. Wipe up any gasoline that spills.
- Do not fill the fuel tank completely full. Add gasoline to the fuel tank until the level is 1/4" to 1/2" (6 mm to 13 mm) below the bottom of the filler neck. This empty space in the tank allows gasoline to expand.
- Never smoke when handling gasoline, and stay away from an open flame or where gasoline fumes may be ignited by a spark.
- Store gasoline in an approved container and keep it out of the reach of children. Never buy more than a 30-day supply of gasoline.

### DANGER

#### POTENTIAL HAZARD

- In certain conditions gasoline is extremely flammable and highly explosive.

#### WHAT CAN HAPPEN

- A fire or explosion from gasoline can burn you, others, and cause property damage.

#### HOW TO AVOID THE HAZARD

- Always place gasoline containers on the ground away from your vehicle before filling.
- Do not fill gasoline containers inside a vehicle or on a truck or trailer bed because interior carpets or plastic truck bed liners may insulate the container and slow the loss of any static charge.
- When practical, remove gas-powered equipment from the truck or trailer and refuel the equipment with its wheels on the ground.
- If this is not possible, then refuel such equipment on a truck or trailer from a portable container, rather than from a gasoline dispenser nozzle.
- If a gasoline dispenser nozzle must be used, keep the nozzle in contact with the rim of the fuel tank or container opening at all times until fueling is complete.

## Stabilizer/Conditioner

Add the correct amount of gas stabilizer/conditioner to the gas. Using a stabilizer/conditioner in the machine:

- Keeps gasoline fresh during storage
- Cleans the engine while it runs
- Eliminates gum-like buildup in the fuel system, which causes hard starting

**IMPORTANT: Never use fuel additives containing methanol or ethanol.**

## Filling the Fuel Tank

1. Shut the engine off and set the parking brake.
2. Clean around each fuel tank cap and remove the cap. Add unleaded regular gasoline to both fuel tanks, until the level is 1/4 to 1/2 inch (6 mm to 13 mm) below the bottom of the filler neck. This space in the tank allows gasoline to expand. Do not fill the fuel tanks completely full.
3. Install fuel tank caps securely. Wipe up any gasoline that may have spilled.

## Check Engine Oil Level

Before you start the engine and use the machine, check the oil level in the engine crankcase; refer to Checking Oil Level, page 23.

# Set-up

## Loose Parts

**Note:** Use the chart below to verify all parts have been shipped.

| DESCRIPTION                         | QTY. | USE                           |
|-------------------------------------|------|-------------------------------|
| Spacer                              | 1    | Install steering wheel        |
| Steering wheel                      | 1    |                               |
| Roll pin 1/4 x 2-1/2" (64 mm)       | 1    |                               |
| Seat                                | 1    | Install seat                  |
| Bolt 5/16-18 x 1" (25 mm)           | 4    |                               |
| Lock nut 5/16-18                    | 4    |                               |
| R-clamp                             | 1    |                               |
| Weight                              | 2    | Install on rear weight        |
| Bolt 1/2-13 x 3-1/2" (89 mm)        | 4    |                               |
| Washer 1/2" (13 mm)                 | 4    |                               |
| Lock washer 1/2" (13 mm)            | 4    |                               |
| Nut 1/2"                            | 4    |                               |
| Carriage bolt 1/4-20 x 3/4" (19 mm) | 2    | Install battery cables        |
| Wing nut 1/4-20                     | 2    |                               |
| Operator's Manual                   | 1    | Rear before operating machine |
| Parts catalog                       | 1    |                               |
| Registration card                   | 1    | Fill out and return to Toro   |

## Install Seat

1. Position seat assembly onto seat plate aligning mounting holes (Fig. 1).
2. Slide wire clamp over seat switch wire (Fig. 1).
3. Using left front hole, loosely secure wire clamp and seat to seat base with capscrews and lock nuts (Fig. 1).
4. Mount seat to seat base with (3) remaining bolts and lock nuts.
5. Rout seat switch wire thru slot in seat plate and plug connector onto seat switch (Fig. 1).
6. Tighten all lock nuts and check operation of seat.
7. Make sure wire harness is clear of lift arm and all moving parts.

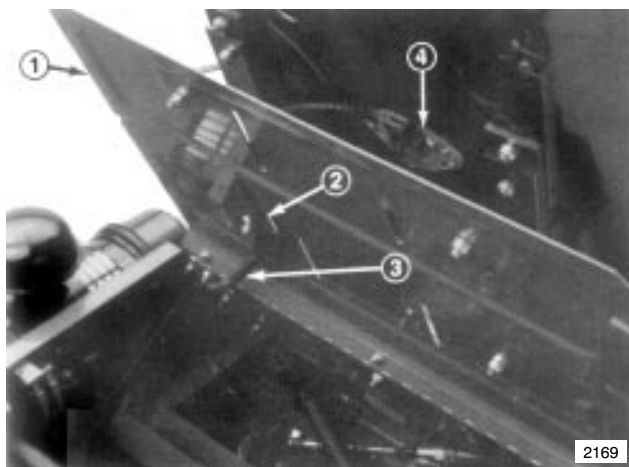
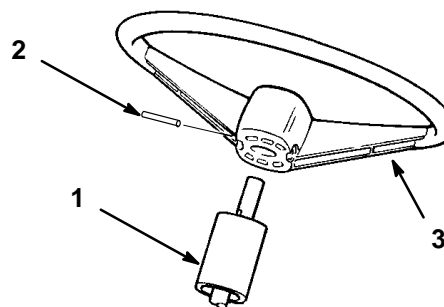

**Figure 1**

- |               |                          |
|---------------|--------------------------|
| 1. Seat plate | 3. Seat switch wire      |
| 2. R-clamp    | 4. Seat switch connector |

## Install Steering Wheel

1. Move rear wheels so they point straight ahead.
2. Slide spacer and steering wheel onto steering shaft aligning mounting holes. Check that logo on steering cap points forward.
3. Secure steering wheel to shaft with roll pin (Fig. 2).



M-4263

**Figure 2**

- |             |                   |
|-------------|-------------------|
| 1. Spacer   | 3. Steering Wheel |
| 2. Roll pin |                   |

## Install Rear Weights

1. Attach two (2) weights onto existing weight with (4) 1/2 x 3-1/2" (89 mm) bolts, (4 ea.) 1/2" washers, 1/2" lock washers and 1/2" nuts (Fig. 3).

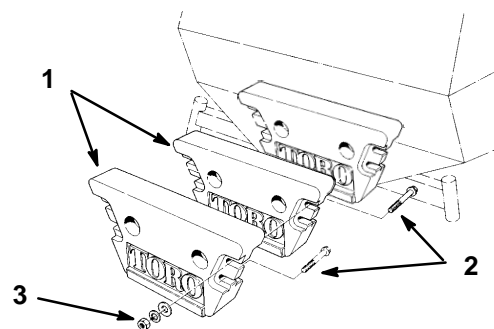

m-2907

**Figure 3**

- |                                |                                |
|--------------------------------|--------------------------------|
| 1. Weight                      | 3. Washer, lock washer and nut |
| 2. Bolt 1/2-13 x 3-1/2 (89 mm) |                                |

## Activate the Battery

Bulk electrolyte with 1.260 specific gravity must be purchased from a local battery supply outlet.

1. If already installed, remove the battery from the holder.

### DANGER

#### POTENTIAL HAZARD

- Battery electrolyte contains sulfuric acid which is a deadly poison and it causes severe burns.

#### WHAT CAN HAPPEN

- If you carelessly drink electrolyte you could die or if it gets onto your skin you will be burned.

#### HOW TO AVOID THE HAZARD

- Do not drink electrolyte and avoid contact with skin, eyes or clothing. Wear safety glasses to shield your eyes and rubber gloves to protect your hands.
- Fill the battery where clean water is always available for flushing the skin.
- Follow all instructions and comply with all safety messages on the electrolyte container.

2. Remove filler caps from the battery. Slowly pour electrolyte into each cell until the electrolyte level is up to the lower part of the tube (Fig. 4).

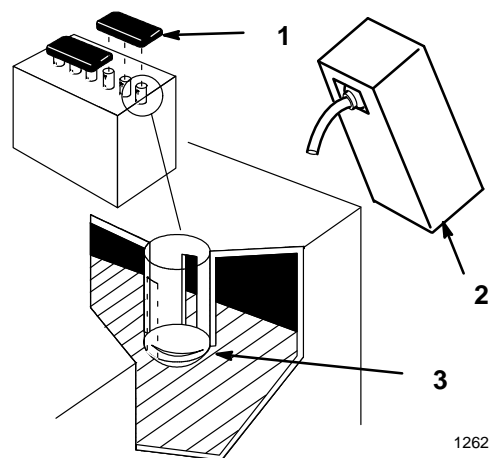

Figure 4

1. Filler caps
2. Electrolyte
3. Lower part of the tube

3. Leave the covers off and connect a 3 to 4 amp battery charger to the battery posts (Fig. 5). Charge the battery at a rate of 4 amperes or less for 4 hours (12 volts).

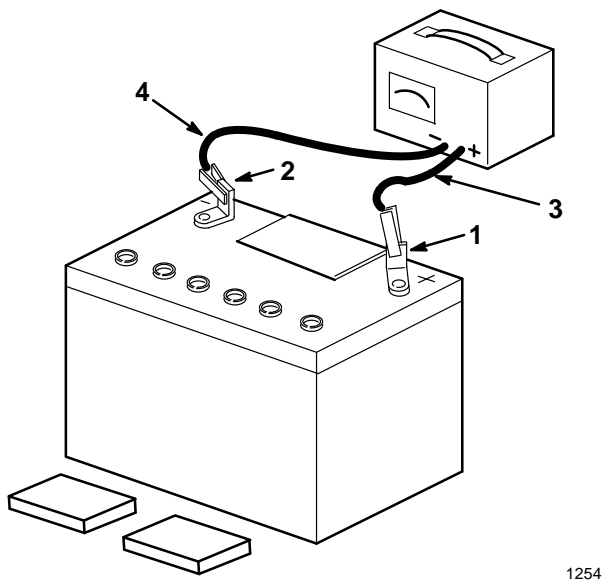

Figure 5

1. Positive post
2. Negative post
3. Charger red (+) wire
4. Charger black (-) wire

**! WARNING****POTENTIAL HAZARD**

- Charging battery produces gasses.

**WHAT CAN HAPPEN**

- Battery gasses can explode.

**HOW TO AVOID THE HAZARD**

- Keep cigarettes, sparks and flames away from battery.

4. When the battery is fully charged, disconnect the charger from the electrical outlet then from the negative and positive battery posts (Fig. 5).
5. Slowly pour electrolyte into each cell until the level is up to the lower part of the tube (Fig. 4) and install covers.
6. Install the battery into the holder.

## Install the Battery

**IMPORTANT: Activate battery with electrolyte and charge before installing.**

1. Mount battery on battery support with terminal posts toward gas tank (Fig. 6).
2. Secure battery with clamp, support rod and wing nut (Fig. 6).

**Note:** DO NOT OVERTIGHTEN.

3. Slide the red terminal boot onto the red battery cable (Fig. 6).
4. Install the positive battery cable to positive (+) battery terminal and the negative battery cable to the negative (-) battery terminal and secure with carriage bolts and lock nuts (Fig. 6).

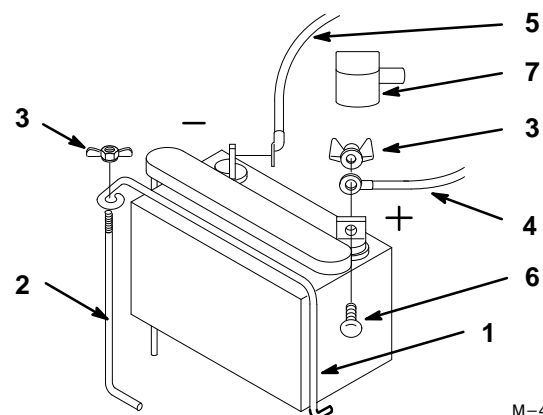

M-4282

**Figure 6**

- |                           |                           |
|---------------------------|---------------------------|
| 1. Clamp                  | 5. Negative battery cable |
| 2. Support rod            | 6. Carriage Bolt          |
| 3. Wing nut               | 7. Terminal Boot          |
| 4. Positive battery cable |                           |

## Check Engine Oil

The engine is shipped with 4 pints of oil in the crankcase; however, oil level must be checked before and after the engine is first started. Check oil level; refer to Checking Oil Level, page 23.

## Check Hydraulic System Fluid

The hydraulic system is shipped with approximately 5 quarts of 10W-30 engine oil; however, oil level must be checked before the engine is first started. Check oil level; refer to Check Hydraulic System Fluid, page 34.

# Operation

## Think Safety First

Please carefully read all the safety instructions and symbols in the safety section. Knowing this information could help you, your family, pets or bystanders avoid injury.

Become familiar with all the controls before you start the engine and operate the machine.

## Starting and Stopping the Engine

### Starting

1. Make sure spark plug wire(s) are installed on spark plug(s).
2. Move the traction pedal to neutral, set the parking brake and move the PTO switch to “OFF.”
3. Move the choke control to the “CHOKE” position before starting a cold engine.

**Note:** A warm or hot engine may not require any choking.

4. Rotate ignition key to “START.” When engine starts, release key, gradually move choke to run and regulate throttle to desired speed.

**IMPORTANT: To prevent overheating of the starter motor, do not engage starter longer than 10 seconds. After 10 seconds of continuous cranking, wait 60 seconds before engaging starter motor again.**

### Stopping

1. Move the throttle lever to “SLOW” (Fig. 7).

**Note:** If the engine has been working hard or is hot, let it idle for a minute before turning the ignition key “OFF.” This helps cool the engine before it is stopped. In an emergency, the engine may be stopped by turning the ignition key to “OFF.”

2. Turn the ignition key to “OFF” (Fig. 7).
3. Set the parking brake.
4. Pull wire off spark plug(s) to prevent possibility of accidental starting before storing machine.

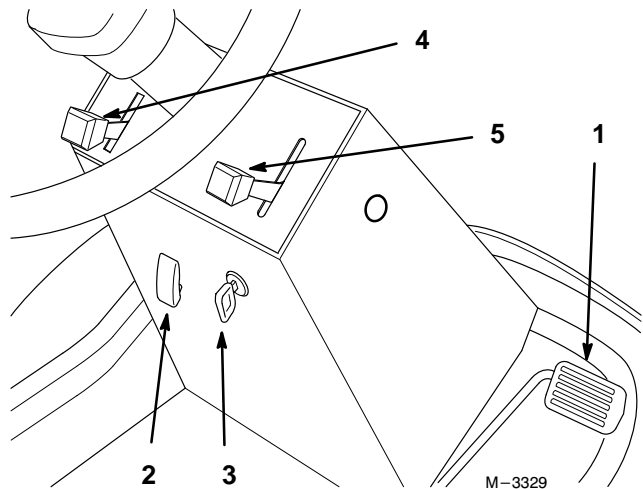

Figure 7

- |                    |             |
|--------------------|-------------|
| 1. Traction pedal  | 4. Choke    |
| 2. PTO switch      | 5. Throttle |
| 3. Ignition switch |             |

## Operating the Power Take Off (PTO)

The power take off (PTO) switch engages and disengages power to the electric clutch.

### Engaging the PTO

1. Release pressure on the traction pedal to stop movement. (Fig. 8).
2. To engage lift cover and move the PTO switch to the “ON” position (Fig. 8).

### Disengaging the PTO

1. Closing the cover moves the PTO switch to the “OFF” position (Fig. 8).

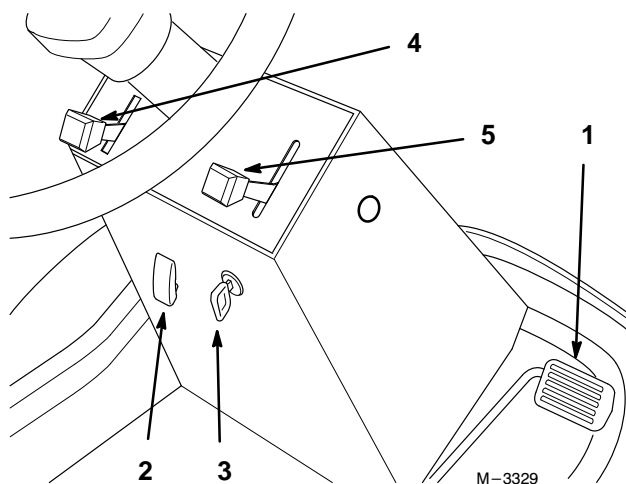

Figure 8

- |                    |             |
|--------------------|-------------|
| 1. Traction pedal  | 4. Choke    |
| 2. PTO switch      | 5. Throttle |
| 3. Ignition switch |             |

## Driving Forward or Backward

The throttle control regulates the engine speed as measured in rpm (revolutions per minute). Move the throttle control to the “FAST” position for best performance.

### Forward

1. To go forward, place your foot on the traction pedal (Fig. 8).
2. Release the parking brake.
3. Slowly press on the upper pad of the traction pedal to move forward (Fig. 8).

### Backward

1. To go backward, place your foot on the traction pedal (Fig. 8).
2. Release the parking brake.
3. Slowly press on the lower pad of the traction pedal to move rearward (Fig. 8).

## Stopping the Machine

To stop the machine, release pressure on the traction pedal, move the PTO switch to “OFF” and turn the ignition key to “OFF” to stop the engine and remove the key. Also set the parking brake if you leave the machine unattended; refer to Setting the Parking Brake, page 18.

### **! CAUTION**

#### POTENTIAL HAZARD

- Someone could move or attempt to operate the machine while it is unattended.

#### WHAT CAN HAPPEN

- Children or bystanders may be injured if they use the machine.

#### HOW TO AVOID THE HAZARD

- Always remove the ignition key and set the parking brake when leaving the machine unattended, even if just for a few minutes.

## Parking Brake

Always set the parking brake when you stop the machine or leave it unattended.

### Setting the Parking Brake

1. Release pressure on the traction pedal to stop movement.
2. Lift the parking brake lever up (Fig. 9) to apply the parking brake.

### Releasing the Parking Brake

1. Move the parking brake lever down (Fig. 9) to release the parking brake.

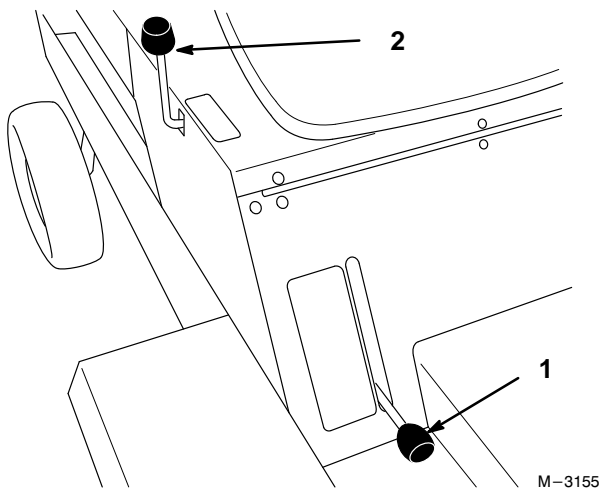

**Figure 9**

1. Parking brake
2. Implement lift lever

## Implement Lift Lever

The implement lift lever (Fig. 9) is used to raise and lower various attachments.

**Note:** When done using implement engage lock bracket and tighten knob.

### Raising Attachments

1. Remove pressure from traction pedal to stop the machine.
2. Loosen the lock bracket knob. Move bracket back and tighten knob (Fig. 10).
3. Pull implement lift lever (Fig. 9) rearward to raise attachment to the desired height.

### Lowering Attachments

1. Remove pressure from traction pedal to stop the machine.
2. Loosen the lock bracket knob. Move bracket back and tighten knob (Fig. 10).
3. Push implement lift lever (Fig. 9) forward to lower attachment.

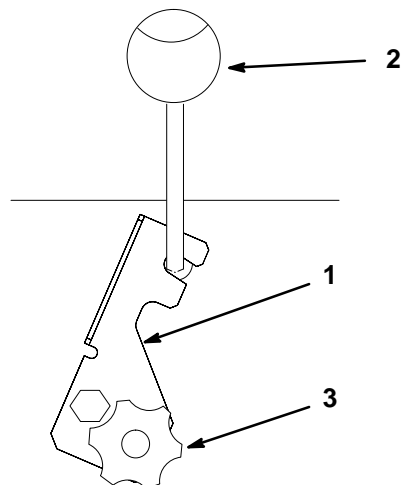

**Figure 10**

1. Lock Bracket
2. Implement lift lever
3. Knob

## The Safety Interlock System

### Understanding the Safety Interlock System

The safety interlock system is designed to prevent the engine from rotating or starting unless:

- The traction pedal is in neutral
- The power take off (PTO) is disengaged

The safety interlock system is designed to stop the engine if you rise from the seat when the power take off (PTO) is engaged or the motion control is not in neutral.

### Testing the Safety Interlock System

Test the safety interlock system before you use the machine each time. If the safety system does not operate as described below, have an Authorized Service Dealer repair the safety system immediately.

1. Switch the power take off (PTO) “ON”. Now turn the key to “START”; the engine should not rotate.
2. Turn the power take off (PTO) “OFF” and move the motion control (forward or reverse). Now turn the ignition key to “START”; the engine should not rotate.
3. Set the parking brake, move the power take off (PTO) to disengaged, motion control to neutral and start the engine. While the engine is running, engage the power take off (PTO) and rise slightly from the seat; the engine should stop.
4. Set the parking brake, move the power take off (PTO) to disengaged, motion control to neutral and start the engine. While the engine is running, slowly move the motion control (forward or reverse) ; the engine should stop.

**IMPORTANT: The unit can be started when all controls are in a safe position, without the operator in the seat, for servicing.**

## Positioning the Seat

The seat can move forward and backward. Position the seat where you have the best control of the machine and are most comfortable.

1. To adjust the seat move lever on left side of seat rearward (Fig. 11).
2. Slide seat to desired position and release lever to lock seat into position.



M-4283

Figure 11

1. Seat adjustment lever

## Pushing or Towing the Machine

In an emergency, the traction unit can be pushed or towed for a very short distance. Toro does not recommend this as standard procedure.

**IMPORTANT: Do not push or tow the traction unit faster than 2 to 3 mph because transmission may be damaged. If traction unit must be moved a considerable distance, transport on a truck or trailer.**

1. To push or tow forward, the traction pedal must be fully depressed forward.
2. To push or tow in reverse, the traction pedal must be fully depressed in reverse.

# Maintenance

## Service Interval Chart

| Service Operation                                      | Each Use | 8 Hours | 25 Hours | 50 Hours | 100 Hours | 200 Hours | Storage Service |
|--|----------|---------|----------|----------|-----------|-----------|-----------------|
| Oil—check level  | X        |         |          |          |           |           | X               |
| Oil—change*  |          | Initial |          | X        |           |           | X               |
| Oil Filter—change* (100 hours, every other oil change) |          |         |          |          | X         |           | X               |
| Safety System—check                                    | X        |         |          |          |           |           | X               |
| Brake—check  | X        | X       |          |          |           |           | X               |
| Engine—clean outside and cooling fins                  | X        |         |          |          | X         |           | X               |
| Bearings\Bushings—grease*                              |          |         | X        |          |           |           | X               |
| Foam Air Cleaner—clean*                                |          |         | X        |          |           |           | X               |
| Paper Air Cleaner—clean*                               |          |         | X        |          |           |           | X               |
| Paper Air Cleaner—replace*                             |          |         |          |          | X         |           | X               |
| Spark Plug(s)—check                                    |          |         |          |          |           | X         | X               |
| Belts—check for wear/cracks                            |          |         |          | X        |           |           | X               |
| Fuel Filter—replace                                    |          |         |          |          | X         |           | X               |
| Battery—check electrolyte level                        |          |         |          | X        |           |           | X               |
| Tires—check pressure                                   |          |         |          | X        |           |           | X               |
| Hydraulic System—change oil (250 hrs)                  |          |         |          |          |           | X         | X               |
| Hydraulic System—change filter (250 hrs)               |          |         |          |          |           | X         | X               |
| Front Axle—change oil (500 hours)                      |          |         |          |          |           |           | X               |
| Chipped Surfaces—paint                                 |          |         |          |          |           |           | X               |
| * More often in dusty, dirty conditions                |          |         |          |          |           |           |                 |

### CAUTION

#### POTENTIAL HAZARD

- If you leave the key in the ignition switch, someone could start the engine.

#### WHAT CAN HAPPEN

- Accidental starting of the engine could seriously injure you or other bystanders.

#### HOW TO AVOID THE HAZARD

- Remove the key from the ignition switch and pull the wire(s) off the spark plug(s) before you do any maintenance. Also push the wire(s) aside so it does not accidentally contact the spark plug(s).

## Belt Guard

You will have to remove the belt guard to perform maintenance under seat and engine cover.

### Removing Belt Guard

1. Raise seat and remove center bolt (Fig. 12).
2. Remove guard from interlock rear lip in rear of opening (Fig. 12).
3. Lift guard out (Fig. 12).

### Installing Belt Guard

1. Raise seat.
2. Interlock rear lip of belt guard into rear of opening (Fig. 12).
3. Secure center bolt into speed nut and belt guard (Fig. 12).

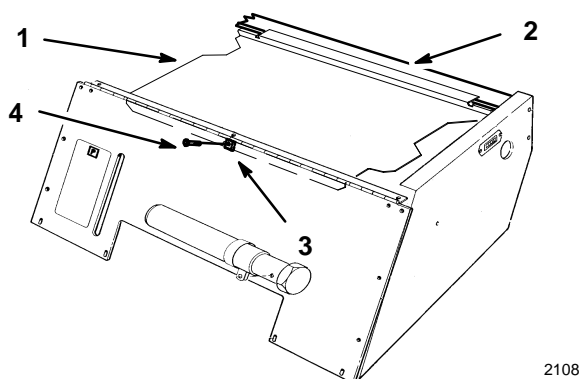

2108

**Figure 12**

- |               |   |
|---------------|---|
| 1. Belt guard | 4. Center Bolt 1/4–20 x 7/8”<br>(22 mm) |
| 2. Rear lip   |   |
| 3. Speed nut  |   |

## Air Cleaner

Foam Element: Clean and re-oil after every 25 operating hours.

Paper Element: Replace after every 100 operating hours.

**Note:** Service the air cleaner more frequently (every few hours) if operating conditions are extremely dusty or sandy.

### Removing the Foam and Paper Elements

1. Raise seat and remove belt guard. See Removing Belt Guard on page 21.
2. Disengage the power take off (PTO), set the parking brake, and turn the ignition key to “OFF” to stop the engine. Remove the key.
3. Clean around the air cleaner to prevent dirt from getting into the engine and causing damage. Unscrew the knob and remove the air cleaner cover (Fig. 13).

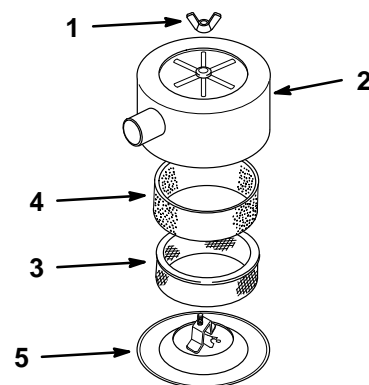

M-4284

**Figure 13**

- |             |                |
|-------------|----------------|
| 1. Wing nut | 4. Pre-filter  |
| 2. Cover    | 5. Filter Base |
| 3. Filter   |                |

4. Carefully slide the foam element off the paper element (Fig. 13).
5. Unscrew the cover nut and remove the cover and paper element (Fig. 13).

### Cleaning the Foam and Paper Elements

#### 1. Foam Element

- A. Wash the foam element in liquid soap and warm water. When the element is clean, rinse it thoroughly.
- B. Dry the element by squeezing it in a clean cloth (do not wring).
- C. Put one or two ounces of oil on the element (Fig. 14). Squeeze the element to distribute the oil.

**IMPORTANT: Replace the foam element if it is torn or worn.**

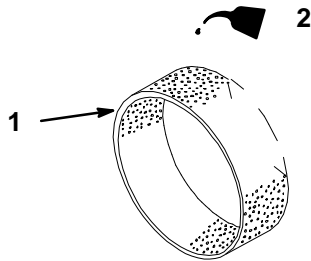

Figure 14

1. Foam element
  2. Oil
- 

#### 2. Paper Element

- A. Lightly tap the element on a flat surface to remove dust and dirt (Fig. 15).
- B. Inspect the element for tears, an oily film, and damage to the rubber seal.

**IMPORTANT: Never clean the paper element with pressurized air or liquids, such as solvent, gas, or kerosene. Replace the paper element if it is damaged, or cannot be cleaned thoroughly.**

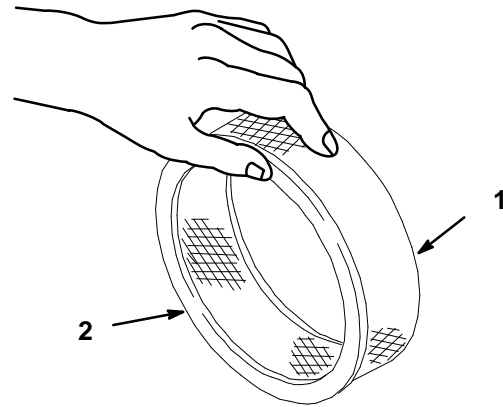

m-1213

Figure 15

1. Paper element
  2. Rubber seal
- 

### Installing the Foam and Paper Elements

#### 1. Installing the Foam and Paper Elements

**IMPORTANT: To prevent engine damage, always operate the engine with the complete foam and paper air cleaner assembly installed.**

1. Carefully slide the foam element onto the paper air cleaner element (Fig. 13).
2. Place the air cleaner assembly onto the air cleaner base (Fig. 13).
3. Install the air cleaner cover and secure with cover nut (Fig. 13).
4. Reinstall belt guard. See Installing Belt Guard on page 21.

## Engine Oil

### Service Interval/Specification

Change oil:

- After the first 8 operating hours.
- After every 50 operating hours.

**Note:** Change oil more frequently when operating conditions are extremely dusty or sandy.

Oil Type: Detergent oil (API service SF, SE/CC, CD or SE)

Crankcase Capacity: w/filter, .94 l (4 pints)

Viscosity: See table below

#### USE THESE SAE VISCOSITY OILS

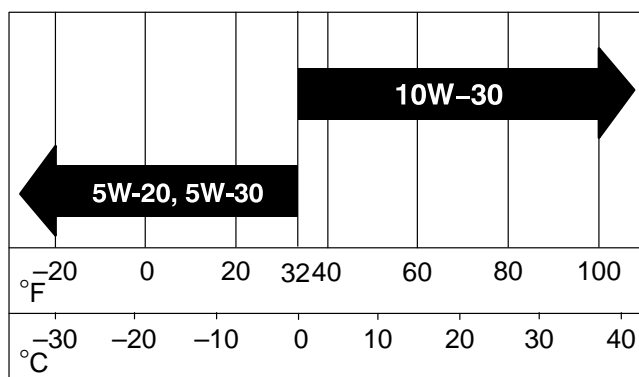

### Checking Oil Level

1. Raise seat and remove belt guard. See Removing Belt Guard on page 21.
  2. Park the machine on a level surface, disengage the power take off (PTO), set the parking brake, and turn the ignition key to “OFF” to stop the engine. Remove the key.
  3. Clean around the oil dipstick and oil fill (Fig. 16) so dirt cannot fall into the filler hole and damage the engine.
  4. Pull the oil dipstick out and wipe the metal end clean (Fig. 16).
  5. Slide the oil dipstick fully into the dipstick tube (Fig. 16). Pull the dipstick out and look at the metal end. If oil level is low, slowly pour only enough oil into the filler hole to raise the level to the “FULL” mark.
- IMPORTANT: Do not overfill the crankcase with oil because the engine may be damaged.**
6. Reinstall belt guard. See Installing Belt Guard on page 21.

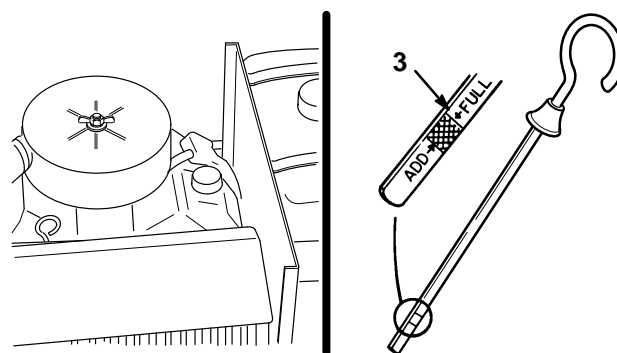

M-4285

**Figure 16**

1. Oil dipstick
2. Oil fill
3. Metal end

## Changing/Draining Oil

1. Start the engine and let it run five minutes. This warms the oil so it drains better.
2. Park the machine so that the drain side is slightly lower than the opposite side to assure the oil drains completely. Then disengage the power take off (PTO), set the parking brake, and turn the ignition key to “OFF” to stop the engine. Remove the key.
3. Place a pan below the oil drain. Remove the oil drain plug (Fig. 17).
4. When oil has drained completely, install the oil drain plug.

**Note:** Dispose of the used oil at a certified recycling center.

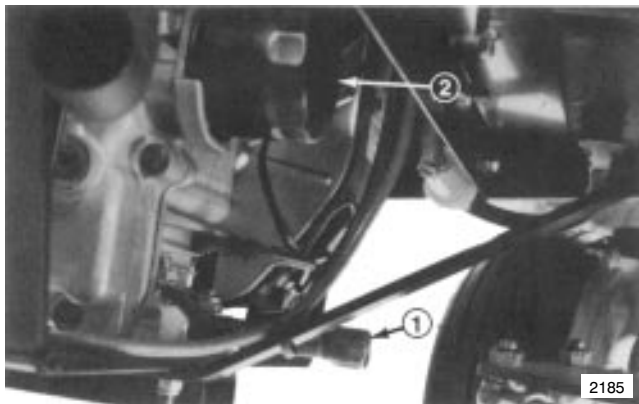

**Figure 17**

1. Oil drain plug

2. Oil filter

5. Slowly pour approximately 80% of the specified amount of oil into the filler tube (Fig. 16). Now check the oil level; refer to Checking Oil Level, page 24. Slowly add additional oil to bring to “FULL” mark on dipstick.

## Change Oil Filter

### Service Interval/Specification

Replace the oil filter every 100 hours or every other oil change.

**Note:** Change oil filter more frequently when operating conditions are extremely dusty or sandy.

1. Drain the oil from the engine; refer to Changing/Draining Oil, page 24.
2. Remove the old filter and wipe the filter adapter (Fig. 17 and 18) gasket surface.
3. Apply a thin coat of new oil to the rubber gasket on the replacement filter (Fig. 18).

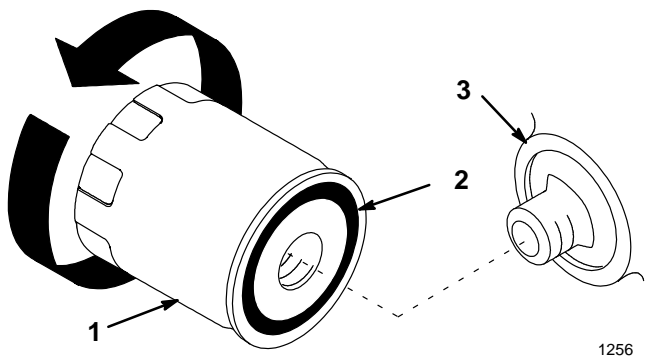

**Figure 18**

1. Oil filter

2. Gasket

3. Adapter

4. Install the replacement oil filter to the filter adapter. Turn the oil filter clockwise until the rubber gasket contacts the filter adapter, then tighten the filter an additional 1/2 turn (Fig. 18).
5. Fill the crankcase with the proper type of new oil; refer to Changing/Draining Oil, page 24.

## Spark Plug

### Service Interval/Specification

Check the spark plug(s) after every 200 operating hours. Make sure the air gap between the center and side electrodes is correct before installing the spark plug. Use a spark plug wrench for removing and installing the spark plug(s) and a gapping tool/feeler gauge to check and adjust the air gap. Install a new spark plug(s) if necessary.

Type: Champion RC 12YC (or equivalent)

Air Gap: 0.040 in. (1 mm)

### Removing the Spark Plug(s)

1. Disengage the power take off (PTO), set the parking brake, and turn the ignition key to "OFF" to stop the engine. Remove the key.
2. Raise seat and remove belt guard. See Removing Belt Guard on page 21.
3. To gain access to the rear spark plug the gas tank must be removed (Fig. 19).

### DANGER

#### POTENTIAL HAZARD

- In certain conditions gasoline is extremely flammable and highly explosive.

#### WHAT CAN HAPPEN

- A fire or explosion from gasoline can burn you, others, and cause property damage.

#### HOW TO AVOID THE HAZARD

- Drain gasoline from the fuel tank when the engine is cold. Do this outdoors in an open area. Wipe up any gasoline that spills.
- Never drain gasoline near an open flame or where gasoline fumes may be ignited by a spark.
- Never smoke a cigarette, cigar or pipe.

4. Rotate tank and set in hood to prevent fuel spilling.
5. Push out plastic cover from access hole in plate between engine and gas tank.
6. Pull the wire(s) off the spark plug(s). Now clean around the spark plug(s) to prevent dirt from falling into the engine and potentially causing damage.
7. Remove the spark plug(s) and metal washer.

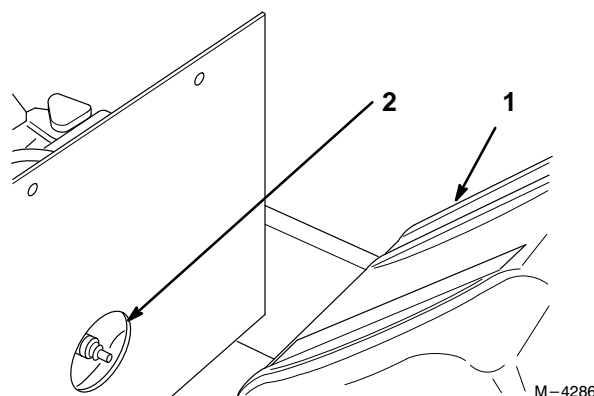

Figure 19

1. Fuel tank
2. Opening for access

### Checking the Spark Plug

1. Look at the center of the spark plug(s) (Fig. 20). If you see light brown or gray on the insulator, the engine is operating properly. A black coating on the insulator usually means the air cleaner is dirty.

**IMPORTANT:** Never clean the spark plug(s). Always replace the spark plug(s) when it has: a black coating, worn electrodes, an oily film, or cracks.

2. Check the gap between the center and side electrodes (Fig. 20). Bend the side electrode (Fig. 20) if the gap is not correct.

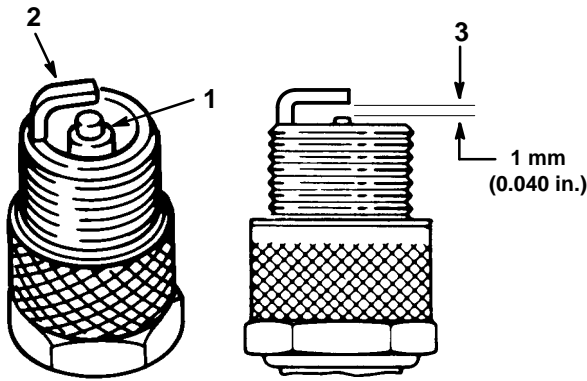

**Figure 20**

1. Center electrode insulator
2. Side electrode
3. Air gap (not to scale)

### Installing the Spark Plug(s)

1. Install the spark plug(s) and metal washer. Make sure the air gap is set correctly.
2. Tighten the spark plug(s) to 17 N m (12 ft. lb).
3. Push the wire(s) onto the spark plug(s) (Fig. 19).
4. Push plastic cover into access hole in plate between engine and gas tank.
5. Lift fuel tank and attach fuel hose, secure with hose clamp.
6. Rotate fuel tank into position, hook straps into lower bracket and secure with capscrews and lock nuts.
7. Reinstall belt guard. See Installing Belt Guard on page 21.

## Greasing and Lubrication

### Service Interval/Specification

Grease all bearings and bushings every 25 operating hours. Grease more frequently (daily) when operating conditions are extremely dusty or sandy.

Grease Type: General-purpose lithium base grease.

### How to Grease

1. Disengage the power take off (PTO), set the parking brake, and turn the ignition key to "OFF" to stop the engine. Remove the key.
2. Clean the grease fittings with a rag. Make sure to scrape any paint off the front of the fitting(s).
3. Connect a grease gun to the fitting. Pump grease into the fittings until grease begins to ooze out of the bearings.
4. Wipe up any excess grease.

### Where to Add Grease

1. Lubricate the wheel bearings (Fig. 21).

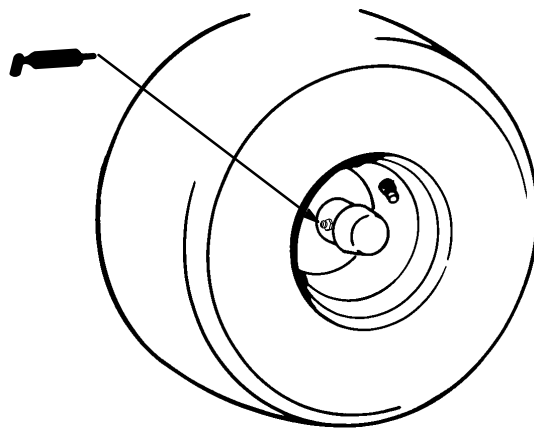

**Figure 21**

M-4287

- Lubricate spindles, steering shaft and pivot (Fig. 22).

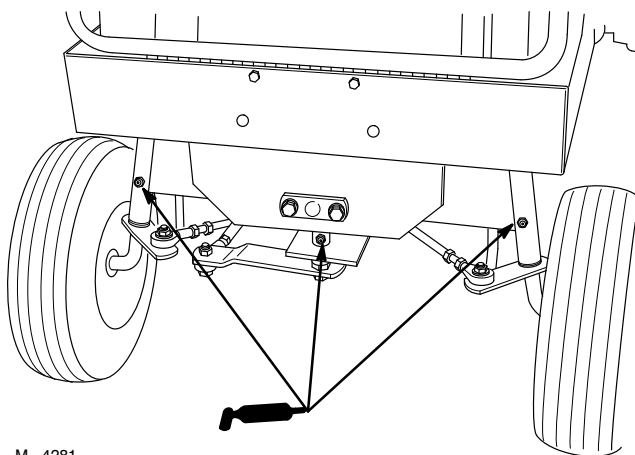
**Figure 22**

- Lubricate the axle bearings (Fig. 23).

Once a year, grease front wheel hub to prevent the formation of rust and to simplify future wheel removal.

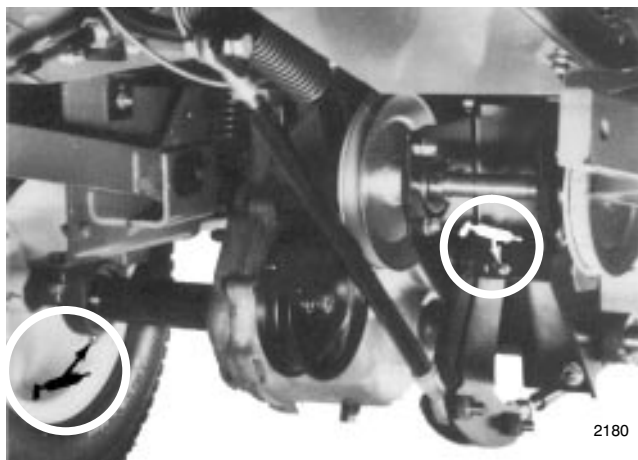
**Figure 23**

- Lubricate the traction pedal bushings with a few drops of SAE 10W-30 oil or dry spray lube and the steering shaft (Fig. 24).

**Figure 24**

## Brake

Always set the parking brake when you stop the machine or leave it unattended. If the parking brake does not hold securely, an adjustment is required.

### Checking the Brake

1. Park the machine on a level surface, disengage the power take off (PTO), set the parking brake, and turn the ignition key to "OFF" to stop the engine. Remove the key.
2. Drive wheels must lock when the brake is applied. Adjustment is required if the wheels turn and do not lock; refer to Adjusting the Brake, page 28.
3. Release the brake, wheels should rotate freely.
4. If both conditions are met no adjustment is required.

**IMPORTANT: With the parking brake released, the drive wheels must rotate freely. If brake action and free wheel rotation cannot be achieved contact your service dealer immediately.**

### Adjust the Brake

If drive wheels do not rotate freely when brake lever is in the OFF position, or brake does not hold when lever is in the ON position, an adjustment is required.

1. Move brake lever to the ON position.
2. Measure distance between disc brake actuating arm and stop pin on axle bracket assembly (Fig. 25). Distance should be less than 1/4 inch (6 mm).
3. If distance is greater than 1/4 inch (6 mm), tighten locknut to decrease distance between actuating arm and stop pin (Fig. 25).
4. With the brake lever OFF, check clearance between brake pads and disc with a feeler gauge (Fig. 25). Proper clearance is approximately .010 inch (.25 mm).
5. The actuating arm should be no more than 3/8 inch (10 mm) away from stop with brake lever in the ON position.
6. Check the brake operation again; refer to Checking the Brake, page 28.
7. Check adjustment. Drive wheels should rotate freely when brake lever is in the OFF position.

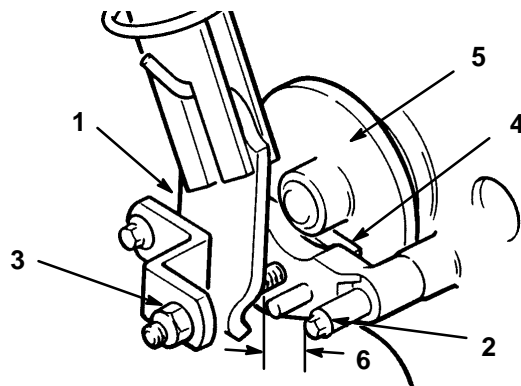

2183

**Figure 25**

- |                        |                   |
|------------------------|-------------------|
| 1. Brake actuating arm | 4. Brake pad (2)  |
| 2. Stop pin            | 5. Disc           |
| 3. Lock nut            | 6. 1/4 inch (6mm) |

## Fuel Filter

### Service Interval/Specification

Replace the fuel filter after every 100 operating hours or yearly, whichever occurs first.

### Replacing the Fuel Filter

Never install a dirty filter if it is removed from the fuel line.

1. Disengage the power take off (PTO), set the parking brake, and turn the ignition key to "OFF" to stop the engine. Remove the key.
2. Have a container ready to drain fuel from the tank. It is best to change fuel filter when fuel tank is almost empty.
3. Loosen hose clamps and slide them up the hose, away from the filter (Fig. 26).
4. Remove the filter from the fuel lines (Fig. 26).
5. Install a new filter, if the filter has an arrow, install with arrow pointing toward the carburetor.
6. Move the hose clamps close to the filter and tighten.

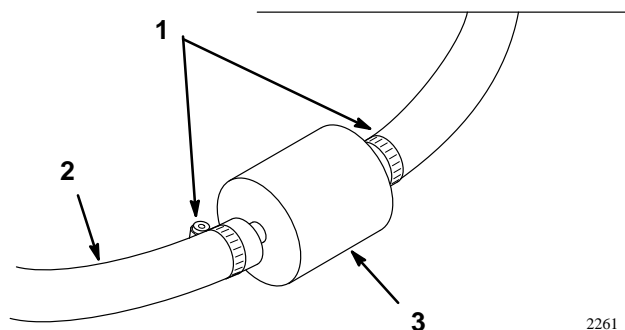

**Figure 26**

- |               |           |
|---------------|-----------|
| 1. Hose clamp | 3. Filter |
| 2. Fuel line  |           |

## Tire Pressure

### Service Interval/Specification

Maintain the air pressure in the front and rear tires as specified. Check the pressure at the valve stem after every 50 operating hours or monthly, whichever occurs first (Fig. 27). Check the tires when they are cold to get the most accurate pressure reading.

Pressure: .103 kPa (15 psi) front and rear

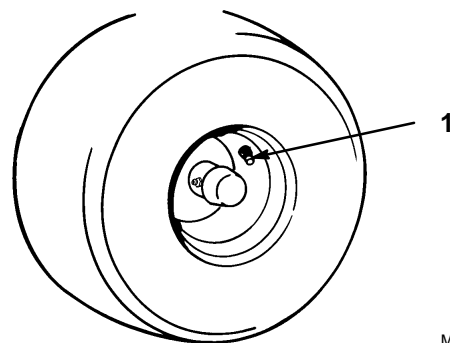

M-4287

**Figure 27**

1. Valve stem

## Cleaning the Cooling System

### Service Interval/Specification

Before each use, remove grass clippings, dirt and grime from the entire machine, muffler and engine air intake screen. Every 100 operating hours clean dirt and chaff from the engine cylinder head fins and blower housing. This will help insure adequate cooling and reduce the possibility of overheating and mechanical damage to the engine.

1. Raise seat and remove belt guard. See Removing Belt Guard on page 21.
2. Open hood and pull spark plug wire(s) off.
3. To avoid overheating and possible engine damage clean, grass, dust, dirt and oil from outside of engine, air intake screen and muffler.
4. To clean cylinder head fins, remove engine from chassis and remove cooling shrouds. Make sure cooling shrouds are re-installed before operating engine.
5. Reinstall belt guard. See Installing Belt Guard on page 21.

## Adjust Belts

If belt slippage occurs, idler pulleys must be adjusted to increase belt tension.

1. Disengage the power take off (PTO), set the parking brake, and turn the ignition key to "OFF" to stop the engine. Remove the key.
2. Raise seat and remove belt guard. See Removing Belt Guard on page 21.
3. Measure distance from bottom of spacer on pulley mounting screw to bottom of slot in idler adjustment link. Distance should be 1/4 inch (6 mm) or less (Fig. 28).
4. Unhook tension spring from side of frame (Fig. 28).
5. To adjust, remove cotter pin and washer securing idler adjustment link to spring anchor (Fig. 28).
6. Slide link off mounting pin and select new hole until bottom of spacer is within 1/4 inch from bottom of slot (Fig. 28).
7. Reposition link onto spring anchor and secure with washer and cotter pin (Fig. 28).
8. Reinstall belt guard. See Installing Belt Guard on page 21.



**Figure 28**

1. 1/4 in (6 mm) space
2. Idler adjustment

## Replace Belts

To replace traction or jackshaft belt, use the following procedures and belt routing diagram (Fig. 29).

1. Disengage the power take off (PTO), set the parking brake, and turn the ignition key to "OFF" to stop the engine. Remove the key.
2. Raise seat and remove belt guard. See Removing Belt Guard on page 21.
3. Clutch anchor bolt must be removed, and clutch unplugged from wire harness before traction belts can be removed.
4. Release tension in idler pulleys before removing or installing belts (Fig. 28).
5. Install belts, route traction belt over transmission as shown (Fig. 29).
6. Install clutch anchor bolt and plug in connector.

**IMPORTANT: To avoid damage reinstall clutch anchor bolt before connecting wire.**

7. Adjust belt tension; refer to Adjust Belts page 30.
8. Reinstall belt guard. See Installing Belt Guard on page 21.

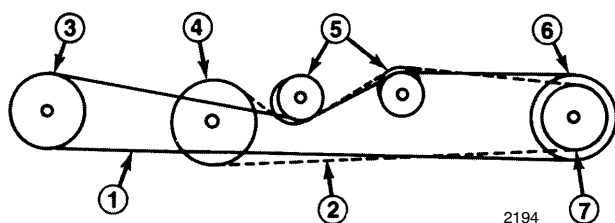
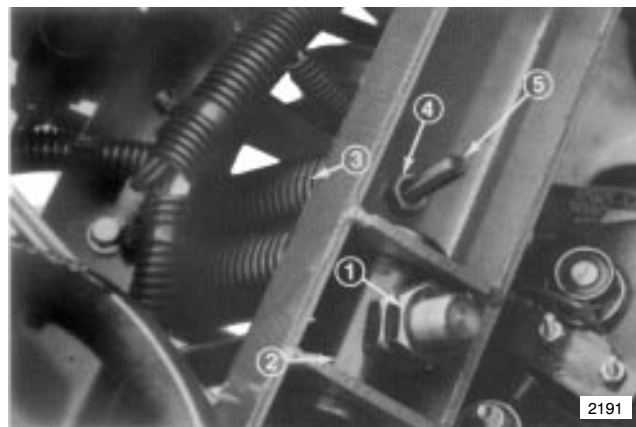

**Figure 29**

- |                        |                  |
|------------------------|------------------|
| 1. Jackshaft belt      | 5. Idler pulley  |
| 2. Traction belt       | 6. Clutch pulley |
| 3. Jackshaft pulley    | 7. Engine pulley |
| 4. transmission pulley |                  |

## Adjust Lift Cylinder and Counterbalance Springs

1. Raise seat and remove belt guard. See Removing Belt Guard on page 21.
2. Start engine and lower lift arms (cutting unit) until lift cylinder is fully extended and lift (cutting unit) is fully lowered.
3. Measure distance between cylinder jam nuts and cylinder pivot pin (Fig. 30). Distance should be approximately 2-1/4 inch.
4. Loosen jam nuts and adjust, if necessary, to attain needed clearance.



**Figure 30**

- |                          |                      |
|--------------------------|----------------------|
| 1. Jam nut               | 4. Adjustment nut    |
| 2. Cylinder pivot pin    | 5. Lift arm "T" hook |
| 3. Counterbalance spring |                      |

5. Start engine and raise lift arms (cutting unit) until lift cylinder is fully retracted and lift (cutting unit) is fully raised.
6. Check distance between clevis pin and bottom hooks of springs (Fig. 28). Distance should be 1/4 inch or less.
7. Adjust nut on lift arm "T" hook to obtain required distance.
8. Reinstall belt guard. See Installing Belt Guard on page 21.

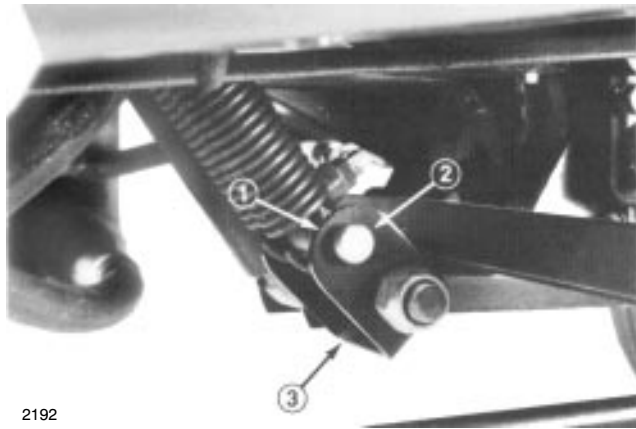

Figure 31

1. 1/4 inch (6 mm) clearance
2. Clevis pin & cotter pin
3. Lift bracket

## Adjust Transmission Neutral

The machine must not creep when traction pedal is released. If it does creep, an adjustment is required.

1. Park machine on a level surface, lower cutting unit and shut engine off. Disengage the PTO and engage the parking brake.
2. Raise seat and remove belt guard. See Removing Belt Guard on page 21.
3. Jack up front of machine until tires are off shop floor. Support machine with jack stands to prevent it from falling accidentally.
4. Loosen lock nut on adjustment cam (Fig. 32).
5. Start engine and rotate adjusting cam in either direction until wheels stop rotating (Fig. 32).

### **WARNING**

#### **POTENTIAL HAZARD**

- Engine must be running so transmission neutral adjustment can be performed.

#### **WHAT CAN HAPPEN**

- Contact with moving parts or hot surfaces may cause personal injury.

#### **HOW TO AVOID THE HAZARD**

- Keep hands, feet, face and other body parts away from rotating parts, muffler and other hot surfaces.

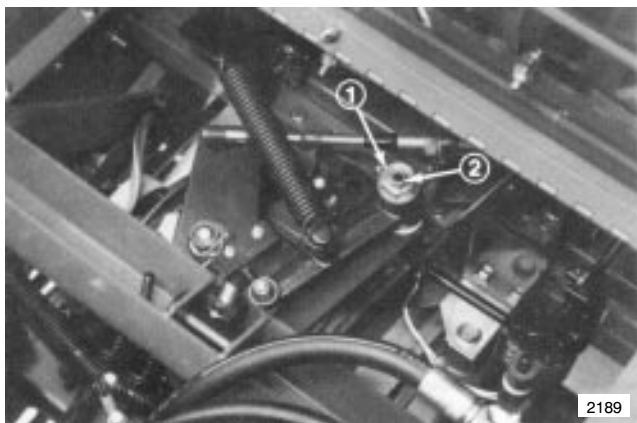
**Figure 32**

1. Adjustment cam

2. Lock nut

6. Stop engine and tighten lock nut to secure adjustment (Fig. 32).
7. Start engine and check adjustment. Repeat adjustment, if necessary.
8. Stop engine. Remove jack stands and lower machine to the shop floor. Test drive the machine to be sure it does not creep.
9. Reinstall belt guard. See Installing Belt Guard on page 21.

## Adjust Electric Clutch

The clutch is adjusted to ensure proper engagement and braking action.

1. Disengage the power take off (PTO), set the parking brake, and turn the ignition key to “OFF” to stop the engine. Remove the key.
2. To adjust clutch, tighten or loosen lock nuts on flange studs (Fig. 33).
3. Check adjustment by inserting feeler gauge thru slots next to studs.
4. The proper disengaged clearance between the clutch plates is 0.30-0.45 mm (.012-.018 in.). It will be necessary to check this clearance at each of the three slots to ensure the plates are parallel to each other.

**Figure 33**

1. Lock nut

2. Adjustment slot

## Check Hydraulic System Fluid

The hydraulic system is designed to operate on SAE 10W–30 engine oil or, as a substitute, SAE 10W–40 engine oil. The reservoir is filled at the factory with approximately 4.731 (5 U.S. quarts) of 10W–30 engine oil. Check reservoir oil level before engine is first started and daily thereafter.

1. Raise seat and remove belt guard. See Removing Belt Guard on page 21.
2. Position machine on a level surface and stop the engine.
3. Remove dipstick cap from filler neck (Fig. 34) and wipe it with a clean rag. Insert dipstick cap onto filler neck; then remove it and check level of oil.
4. If level is not within 1/2 inch from full mark on dipstick, add SAE 10W–30 engine oil to raise level to FULL mark. Do not overfill.
5. Install dipstick filler cap onto filler neck (Fig. 34).
6. Run engine for approximately 1 minute, recheck reservoir oil level and add as required.
7. Reinstall belt guard. See Installing Belt Guard on page 21.



**Figure 34**

1. Dipstick cap

## Change Hydraulic System Oil

The hydraulic system oil must be changed after every 250 hours of operation or yearly, whichever comes first. The reservoir has a capacity of approximately 4.731 (5 U.S. quarts).

1. Park machine on a level surface, lower cutting unit, engage parking brake, and shut engine off.
2. Clean the area around the hydraulic oil filter and remove the filter from the bottom of the filter housing. Use bottom type filter wrench (Fig. 35).
3. Disconnect tube assembly and hose assembly from reservoir and allow the oil to flow into a drain pan (Fig. 35).

**Note:** To drain oil remaining in system, disconnect spark plug wires and crank engine for 15 seconds. This will pump remaining oil out of system thru tube assembly. Do not crank engine for more than 15 seconds.

4. Install the new hydraulic filter onto bottom of the filter housing (Fig. 35).
5. Install the tube assembly and hose assembly to reservoir (Fig. 35).

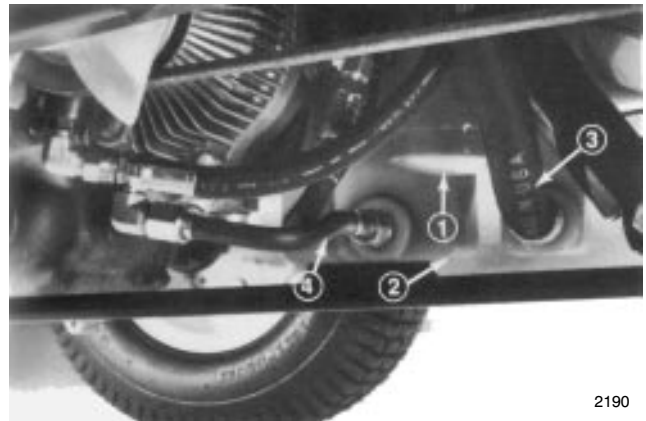

2190

**Figure 35**

- |              |                  |
|--------------|------------------|
| 1. Filter    | 3. Hose assembly |
| 2. Reservoir | 4. Tube assembly |

6. Fill the reservoir to the proper level; refer to Check Hydraulic System Fluid.
7. Place all controls in neutral or disengaged position and start engine. Run engine at lowest possible RPM to purge the system of air.
8. Run engine until lift cylinder extends and retracts and forward and reverse wheel motion is achieved.
9. Stop the engine and check the oil level in reservoir, add oil if necessary.
10. Check all connections for leaks.

## Change Hydraulic Oil Filter

The hydraulic oil filter keeps the hydraulic system relatively free of contaminants. However, the hydraulic oil filter must be serviced at regular intervals. The intervals are: initially, after the first 5 hours of operation, and thereafter every 250 hours of operation or yearly, whichever comes first. Use a genuine TORO oil filter for replacement.

1. Remove hydraulic oil filter from mounting head. Use bottom type filter wrench (Fig. 35). Dispose of filter properly.
2. Apply a film of oil on the gasket. Install filter by hand until gasket contacts mounting head; then tighten filter an additional 3/4 turn.
3. Start engine and check for oil leaks. Allow engine to run for about 2 minutes so any air in system is purged. Then shut engine off.
4. Check level of oil in reservoir; refer to Check Hydraulic System Fluid, page 34.

## Adjust Steering

1. Measure toe-in distance (at axle height) at front and rear of steering tires. Front measurement must be 0–1/4 inch (6 mm) less than rear measurement.
2. Loosening jam nuts and rotating tie rod to adjust clearance (Fig. 36).
3. Turn steering wheel full left to achieve a full left turn (Fig. 36).
4. Check clearance between left tire and tie rod. There should be 1 inch (25 mm)  $\pm$  1/4 inch (6 mm) clearance at this position.
5. Loosening jam nuts and rotating steering rod to adjust clearance (Fig. 36).
6. Rotate tie rod to move front of tire in or out.
7. Tighten jam nuts when adjustment is correct.

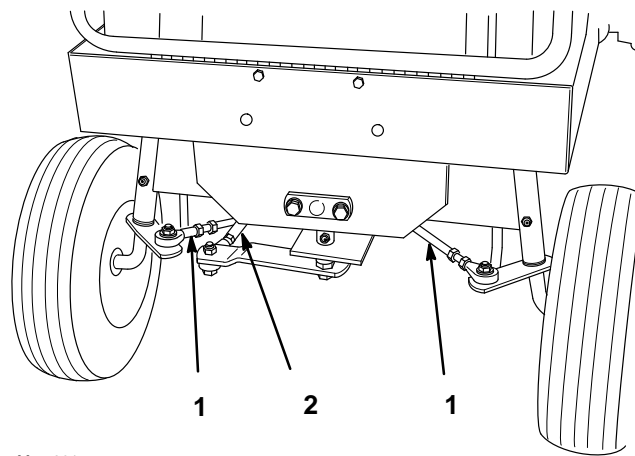

M-4281

**Figure 36**

1. Tie rod
2. Steering rod

# Hydraulic Schematic

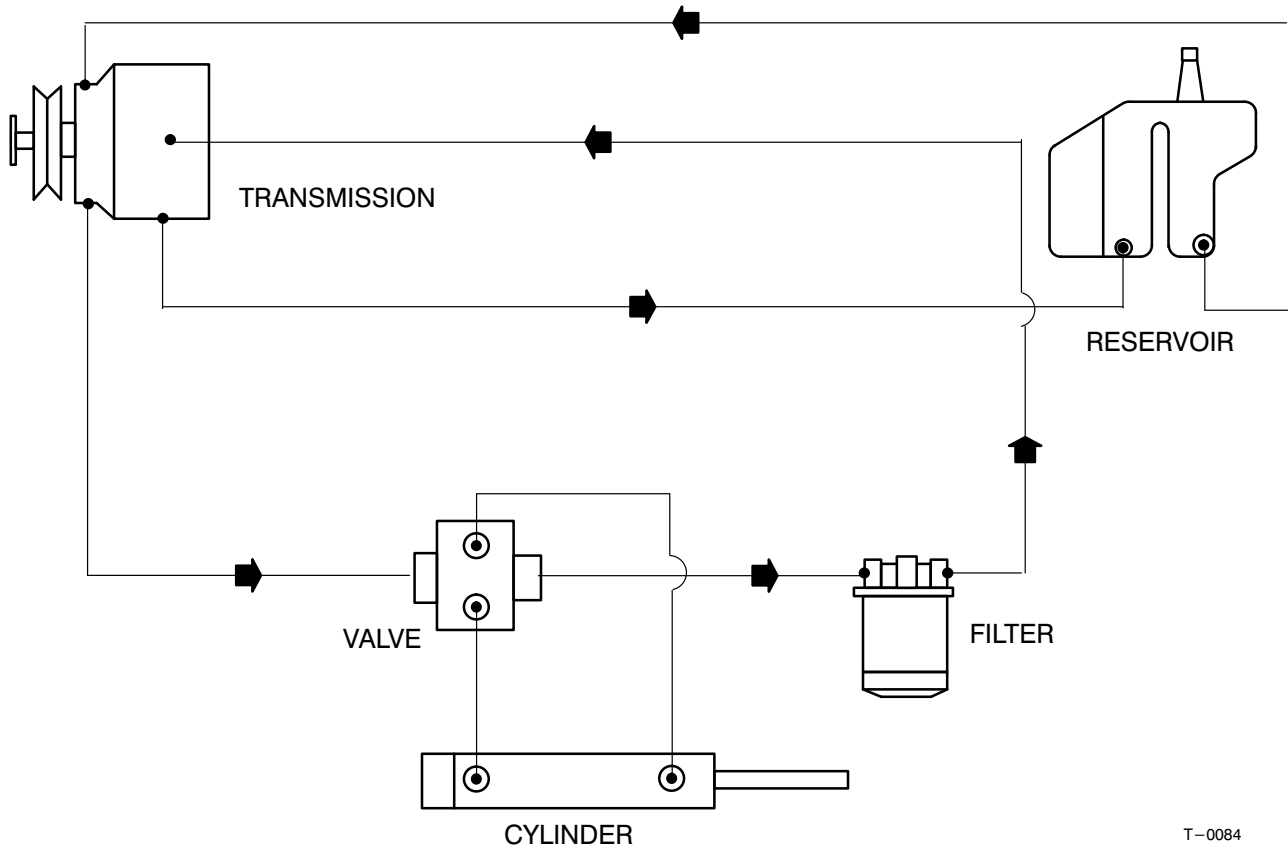

T-0084

## GM 120 QUICK REFERENCE AID



### CHECK/SERVICE

1. OIL LEVELS (ENGINE/TRANS)
2. AXLE OIL
3. TIRE PRESSURE
4. BELT TENSION (TRANS, PTO)
5. FUEL-GAS ONLY
6. BATTERY
7. GREASE, LUBE POINTS
8. ADJUST PARKING BRAKE
9. AIR CLEANER
10. ELECTRIC CLUTCH GAP  
.012-.018
11. DEBRIS UNDER HOOD &  
SEAT PLATE & ENGINE  
COOLING FINS

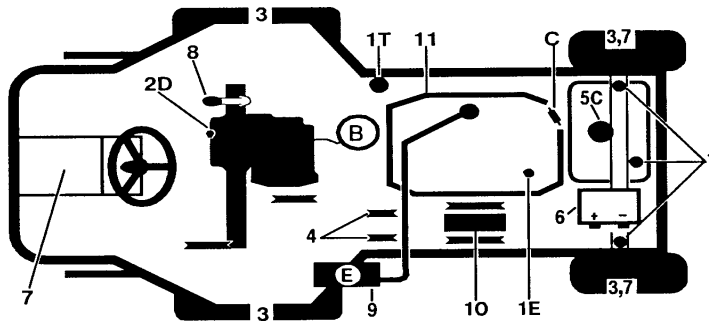

8028-26

### FLUID SPECIFICATION \* SEE OPERATOR'S MANUAL FOR INITIAL CHANGE

| A. ENGINE OIL* | TYPE >                           | TYPE <                         | CAPACITY       | CHANGE INTERVALS | FILTER PART NO.              |
|----------------|----------------------------------|--------------------------------|----------------|------------------|------------------------------|
|                | SAE 10W-30 OR<br>10W-40 SF OR SG | SAE 5W-20 OR<br>5W-30 SF OR SG | 1.9L (4PT.)    | 50 HRS.          | KOHLER<br>12 050 01          |
| B. TRANS OIL   | SAE 10W-30<br>SF-CC,CD           | TYPE F OR FA<br>TRANS FLUID    | 4.73L (5QT.)   | 250 HRS.         | FILTER<br>250 HRS<br>54-0110 |
| C. FUEL        | UNLEADED FUEL                    |                                | 18.93L (5GAL.) | ---              | FILTER<br>400 HRS<br>38-8000 |
| D. AXLE OIL    | SAE E.R 90 WT.                   |                                | 14.9cl (44oz)  | 500 HRS          |                              |
| E. AIR FILTER  | STANDARD                         |                                |                |                  | 33-1300                      |

## Change Front Axle Oil

After every 500 hours of operation, change oil in the front axle.

1. Run machine before changing oil to warm oil. Warm oil flows more freely and carries more contaminants than cold oil.
2. Clean area around drain plug and place a drain pan below drain plug on axle (Fig. 37).
3. Remove drain plug and allow oil to flow into drain pan (Fig. 37). After oil is drained, reinstall drain plug.
4. Remove fill plug and fill to plug level with SAE EP-90 wt. oil (approximately 14.9cl (44 oz.)) (Fig. 37).

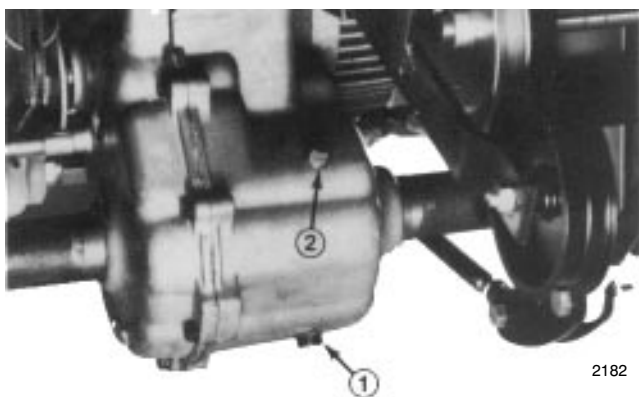

**Figure 37**

1. Drain plug

2. Fill plug

## Battery

### Service Interval/Specification

Check the electrolyte level in the battery every 50 hours. Always keep the battery clean and fully charged. Use a paper towel to clean the battery case. If the battery terminals are corroded, clean them with a solution of four parts water and one part baking soda. Apply a light coating of grease to the battery terminals to prevent corrosion.

Voltage: 12 v, 280 Cold Cranking Amps

### Checking Electrolyte Level

1. Raise seat and remove belt guard. See Removing Belt Guard on page 21.
2. With the engine off, open the covers to see into the cells. The electrolyte must be up to the lower part of the tube (Fig. 38). Do not allow the electrolyte to get below the plates. (Fig. 38).
3. If the electrolyte is low, add the required amount of distilled water; refer to Adding Water to the Battery, page 38.
4. Reinstall belt guard. See Installing Belt Guard on page 21.

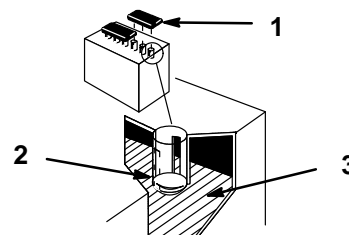

**Figure 38**

1. Filler caps

3. Plates

2. Lower part of tube

1262

## Adding Water to the Battery

The best time to add distilled water to the battery is just before you operate the machine. This lets the water mix thoroughly with the electrolyte solution.

1. Clean the top of the battery with a paper towel.
2. Lift off the filler caps (Fig. 38).
3. Slowly pour distilled water into each battery cell until the level is up to the lower part of the tube (Fig. 38).

**IMPORTANT: Do not overfill the battery because electrolyte (sulfuric acid) can cause severe corrosion and damage to the chassis.**

4. Press the filler caps onto the battery.

## Charging the Battery

**IMPORTANT: Always keep the battery fully charged (1.260 specific gravity). This is especially important to prevent battery damage when the temperature is below 0°C (32°F).**

1. Raise seat and remove belt guard. See Removing Belt Guard on page 21.
2. Remove the battery from the holder.
3. Check the electrolyte level; refer to Checking Electrolyte Level.
4. Remove the filler caps from the battery and connect a 3 to 4 amp battery charger to the battery posts. Charge the battery at a rate of 4 amperes or less for 4 hours (12 volts). Do not overcharge the battery. Install the filler caps after the battery is fully charged.

## WARNING

### POTENTIAL HAZARD

- Charging the battery produces gasses.

### WHAT CAN HAPPEN

- Battery gasses can explode.

### HOW TO AVOID THE HAZARD

- Keep cigarettes, sparks and flames away from battery.

5. Install the battery into the holder.
6. Reinstall belt guard. See Installing Belt Guard on page 21.

## Wire Harness Service

Prevent corrosion of wiring terminals by applying Grafo 112X (Skin-over) grease, Toro Part No. 505-47, to the inside of all harness connectors whenever the harness is replaced.

Whenever working with the electrical system, always disconnect battery cables, negative (-) cable first, to prevent possible wiring damage from short-outs.

**IMPORTANT: Before welding on the machine, disconnect ground cable from the battery to prevent damage to the electrical system.**

# Wiring Diagram

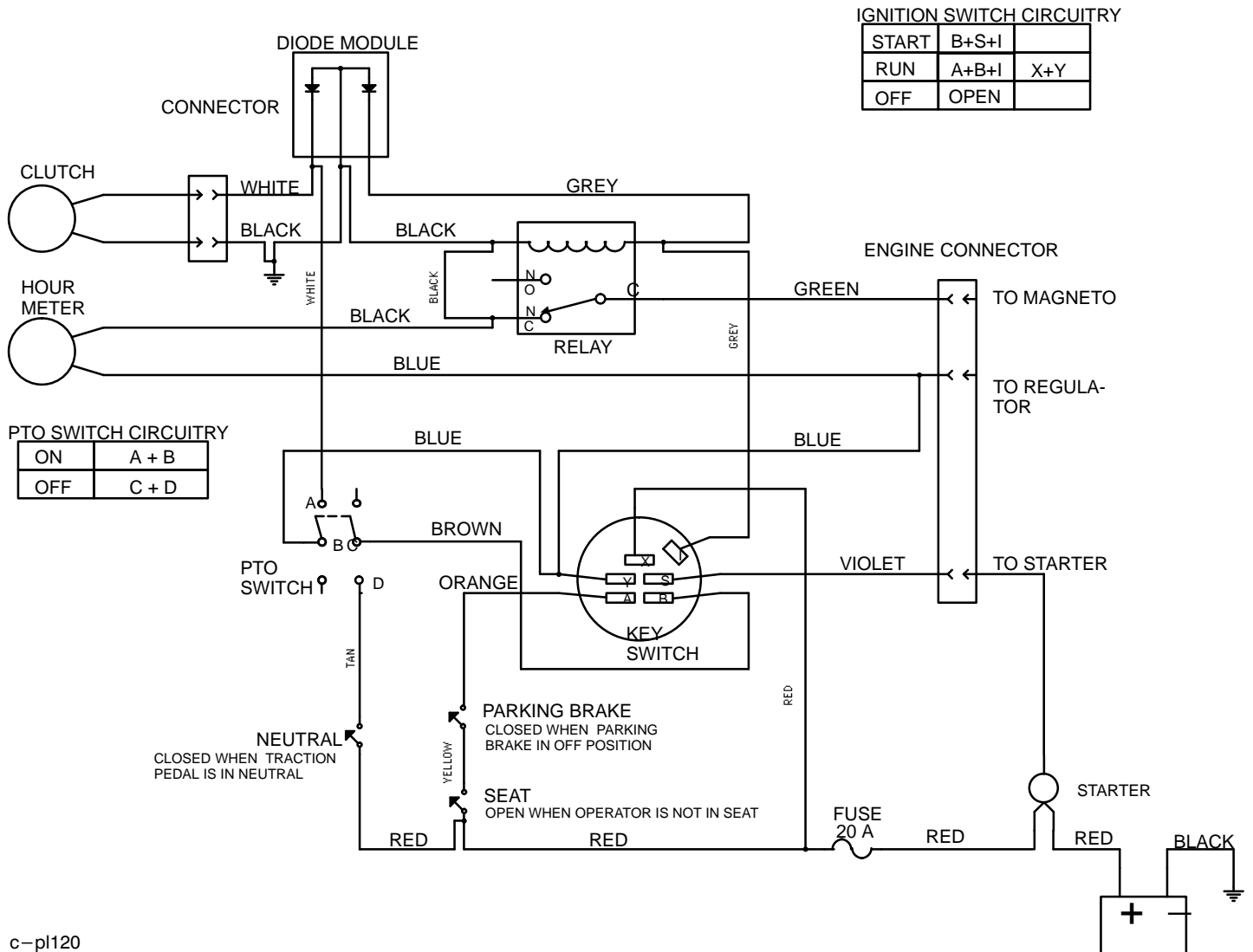

c-pl120

## Cleaning and Storage

1. Disengage the power take off (PTO), set the parking brake, and turn the ignition key to “OFF” to stop the engine. Remove the key.
2. Remove grass clippings, dirt, and grime from the external parts of the entire machine, especially the engine. Clean dirt and chaff from the outside of the engine’s cylinder head fins and blower housing.

**IMPORTANT: You can wash the machine with mild detergent and water. Do not pressure wash the machine. Avoid excessive use of water, especially near the control panel, and engine.**

3. Check the brake; refer to Brake, page 28.
4. Service the air cleaner; refer to Air Cleaner, page NO TAG.
5. Grease the machine; refer to Greasing and Lubrication, page 26.
6. Change the crankcase oil and filter; refer to Engine Oil, page 23.
7. Change the hydraulic system oil and filter; refer to Change Hydraulic Oil and Filter, page 34.
8. Remove the battery from the chassis, check the electrolyte level, and charge fully; refer to Battery, page 37. Do not connect the battery cables to the battery posts during storage.

**IMPORTANT: The battery must be fully charged to prevent it from freezing and being damaged at temperatures below 0° C (32° F). A fully charged battery maintains its charge for about 50 days at temperatures lower than 4° C (40° F). If temperatures will be above 4° C (40° F), check the electrolyte level in the battery and charge every 30 days.**

9. Check the tire pressure; refer to Tire Pressure, page 29.
10. During long-term storage, either drain gasoline from the fuel tank (step 11) or add a fuel stabilizer/conditioner additive to a full tank of gasoline (step A).
11. Drain gasoline from the fuel tank. After fuel is drained, start the engine and let it idle until all gasoline is consumed and the engine stops. This eliminates gum-like buildup in the fuel system, which causes hard starting. Try to start the engine two more times to assure that no gasoline is in the fuel system.
  - A. Add the correct amount of a fuel stabilizer/conditioner to a full tank of gasoline.

**Note:** Stabilizer/conditioners normally preserve gasoline for six to eight months.

- 12.** Remove the spark plug(s) and check its condition; refer to Spark Plug, page 25. With the spark plug(s) removed from the engine, pour two tablespoons of engine oil into the spark plug hole. Now use the starter to crank the engine and distribute the oil inside the cylinder. Install the spark plug(s). Do not install the wire on the spark plug(s).
- 13.** Check and tighten all bolts, nuts, and screws. Repair or replace any part that is damaged or defective.
- 14.** Paint all scratched or bare metal surfaces. Paint is available from your Authorized Service Dealer.
- 15.** Store the machine in a clean, dry garage or storage area. Remove the key from the ignition switch and keep it in a memorable place. Cover the machine to protect it and keep it clean.

# Troubleshooting

| PROBLEM   | POSSIBLE CAUSES  | CORRECTIVE ACTION   |
|---|--|---|
| Starter does not rotate.                                      | <ol style="list-style-type: none"> <li>1. Power take off (PTO) switch is ENGAGED.</li> <li>2. Traction control pedal is not in neutral.</li> <li>3. Electrical connections are corroded or loose.</li> <li>4. Fuse is blown.</li> <li>5. Battery is dead.</li> <li>6. Solenoid or switch is defective.</li> </ol>  | <ol style="list-style-type: none"> <li>1. Move (PTO) switch to DISENGAGED.</li> <li>2. Move traction control pedal to neutral position.</li> <li>3. Check electrical connections for good contact.</li> <li>4. Replace fuse.</li> <li>5. Charge battery.</li> <li>6. Contact Authorized Service Dealer.</li> </ol>  |
| Engine will not start, starts hard, or fails to keep running. | <ol style="list-style-type: none"> <li>1. Operator is not seated.</li> <li>2. Parking brake is OFF.</li> <li>3. Fuel tank is empty.</li> <li>4. Choke is not ON.</li> <li>5. Air cleaner is dirty.</li> <li>6. Spark plug wire is loose or disconnected.</li> <li>7. Spark plug is pitted, fouled, or gap is incorrect.</li> <li>8. Dirt in fuel filter.</li> <li>9. Dirt, water, or stale fuel is in fuel system.</li> </ol>                          | <ol style="list-style-type: none"> <li>1. Sit on seat.</li> <li>2. Move parking brake to ON.</li> <li>3. Fill fuel tank with gasoline.</li> <li>4. Move choke lever to ON.</li> <li>5. Clean or replace air cleaner element.</li> <li>6. Install wire on spark plug.</li> <li>7. Install new, correctly gapped spark plug.</li> <li>8. Replace fuel filter.</li> <li>9. Contact Authorized Service Dealer.</li> </ol> |
| Engine loses power.   | <ol style="list-style-type: none"> <li>1. Engine load is excessive.</li> <li>2. Air cleaner is dirty.</li> <li>3. Oil level in crankcase is low.</li> <li>4. Cooling fins and air passages under engine blower housing are plugged.</li> <li>5. Spark plug is pitted, fouled, or gap is incorrect.</li> <li>6. Vent hole in fuel cap is plugged.</li> <li>7. Dirt in fuel filter.</li> <li>8. Dirt, water, or stale fuel is in fuel system.</li> </ol> | <ol style="list-style-type: none"> <li>1. Reduce ground speed.</li> <li>2. Clean air cleaner element.</li> <li>3. Add oil to crankcase.</li> <li>4. Remove obstruction from cooling fins and air passages.</li> <li>5. Install new, correctly gapped spark plug.</li> <li>6. Clean or replace the fuel cap.</li> <li>7. Replace fuel filter.</li> <li>8. Contact Authorized Service Dealer.</li> </ol>                |

| PROBLEM                 | POSSIBLE CAUSES  | CORRECTIVE ACTION  |
|-------------------------|--|--|
| Engine overheats.       | <ol style="list-style-type: none"> <li>1. Engine load is excessive.</li> <li>2. Oil level in crankcase is low.</li> <li>3. Cooling fins and air passages under engine blower housing are plugged.</li> </ol> | <ol style="list-style-type: none"> <li>1. Reduce ground speed.</li> <li>2. Add oil to crankcase.</li> <li>3. Remove obstruction from cooling fins and air passages.</li> </ol> |
| Abnormal vibration.     | <ol style="list-style-type: none"> <li>1. Engine mounting bolts are loose.</li> <li>2. Loose engine pulley, idler pulley, or blade pulley.</li> <li>3. Engine pulley is damaged.</li> </ol>                  | <ol style="list-style-type: none"> <li>1. Tighten engine mounting bolts.</li> <li>2. Tighten the appropriate pulley.</li> <li>3. Contact Authorized Service Dealer.</li> </ol> |
| Machine does not drive. | <ol style="list-style-type: none"> <li>1. Traction belt is worn, loose or broken.</li> <li>2. Traction belt is off pulley.</li> </ol>  | <ol style="list-style-type: none"> <li>1. Adjust belt tension, replace belt.</li> <li>2. Contact Authorized Service Dealer.</li> </ol>   |





