



**Count on it.**

**Parts Catalog**

**Debris Blower 600**

Model No. 44536—Serial No. 403063082 and Up



# Ordering Replacement Parts

To order replacement parts, please supply the part number, the quantity, and the description of each part desired.

## Understanding Reference Numbers

Each identified part in an illustration has a reference number. The reference number for a part also appears in the parts list, along with other information about the part.

This catalog uses two special reference number formats, one to indicate parts in a service assembly and another to indicate the quantity of a given part in an illustration.

## Service Assembly Reference Numbers

Parts in service assemblies have reference numbers in the form a:b. The a represents the reference number of the entire service assembly and the b represents a sequential number unique to each part within the service assembly.

For example, a wheel assembly might be identified by reference number 6, the tire by 6:1, the valve by 6:2, and the wheel by 6:3. When you order the assembly identified by reference number 6, you receive all parts identified by reference numbers 6:1, 6:2, and 6:3. However, you may also order any part individually. Reference numbers of this type appear in illustration and in parts lists.

## Reference Numbers Indicating Quantity

In an illustration, if a reference number indicates more than one part, the reference number has the form nX y. The n represents the quantity of the part, the X is the multiplication symbol, and the y represents the reference number.

For example, in an illustration, the reference number 2X 37 means that two of the parts identified by reference number 37 are indicated.

# Contents

Housing and Impeller Assembly.....	4
Drive Assembly.....	5
Chute and Roller Assembly.....	7
Drive Shaft Assembly No. 105-4924.....	9
Joint, Shaft and Guard Assembly No. 107-1144.....	10

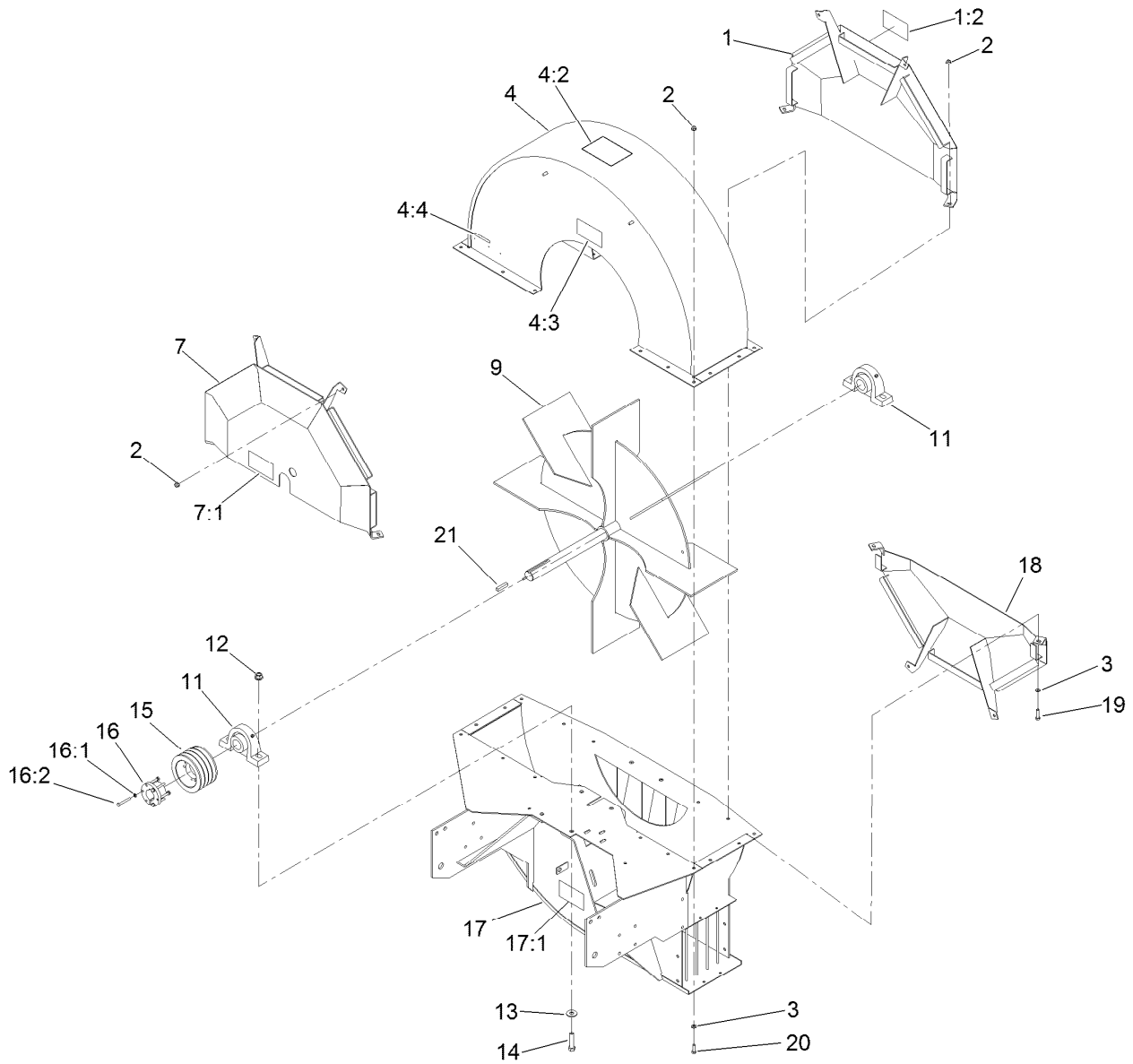

## Housing and Impeller Assembly

Ref.	Part Number	Qty.	Description
1	105-0689	1	Shield-Fan
1:2	67-1300	1	Decal
2	104-8300	23	Nut-HF, NI
3	3256-23	17	Washer-Plain
4	107-1388	1	Blower Top ASM
4:2	98-3110	1	Decal-Caution
4:3	105-0709	2	Decal-Warning
4:4	133-8061	1	Decal-Warning
7	105-0713	1	Shield-Fan, Front
7:1	105-0709	1	Decal-Warning
9	106-0345-01	1	Impeller
11	105-0621	2	Bearing-Block, Pillow
12	99-5107	4	Nut-Lock

Ref.	Part Number	Qty.	Description
13	3256-6	4	Washer-Flat
14	325-9	4	Screw-HH
15	106-0354	1	Pulley
16	106-0359	1	Bushing-Pulley
16:1	321-11	3	Screw-HH
16:2	3253-3	3	Washer-Lock
17	107-1386	1	Frame ASM
17:1	105-0709	2	Decal-Warning
18	LDB11400-01	1	Shield-Fan, Lower
19	322-6	4	Screw-HH
20	322-5	13	Screw-HH
21	41-004-5241	1	Key

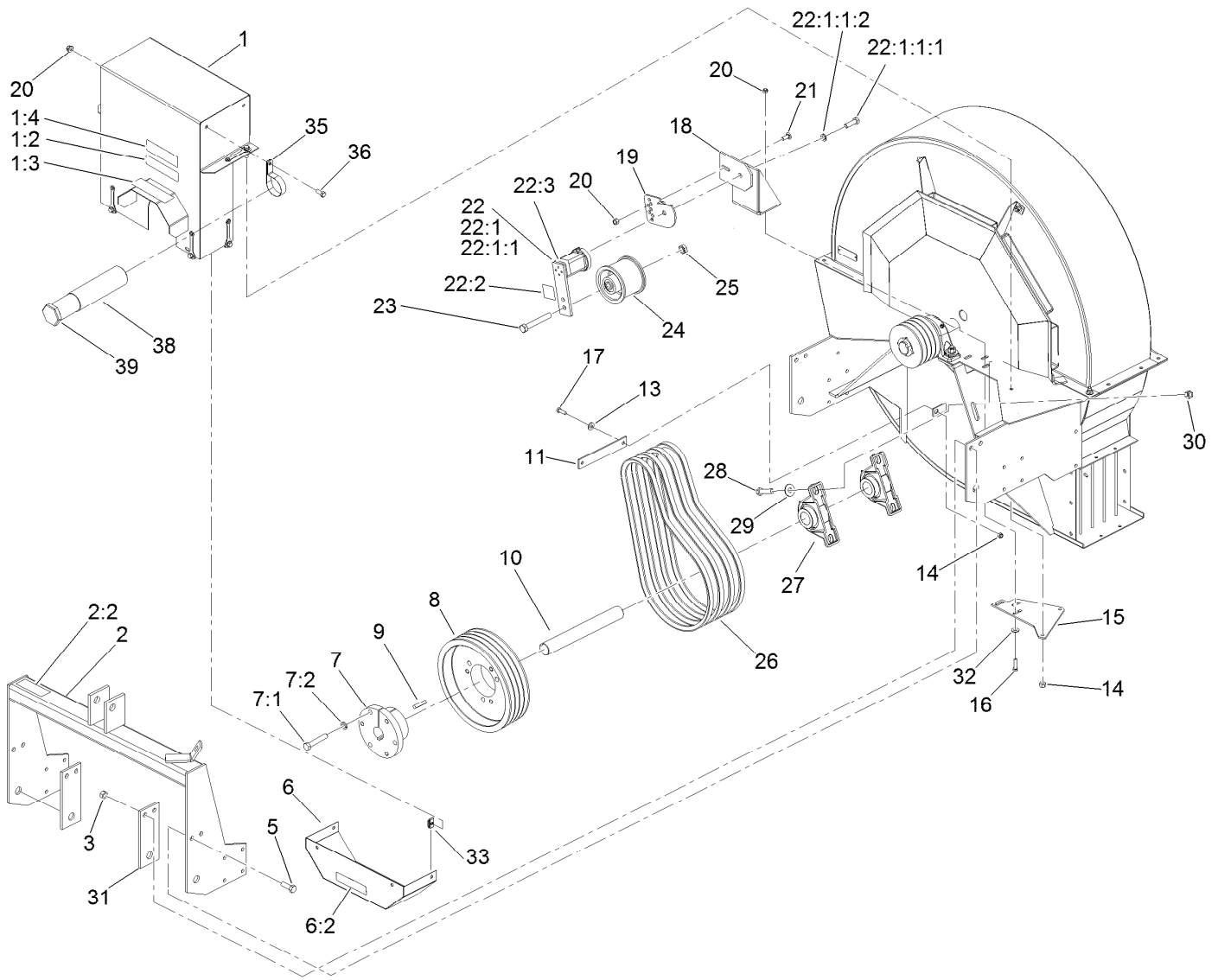

## Drive Assembly

Ref.	Part Number	Qty.	Description	Ref.	Part Number	Qty.	Description
1	119-3011	1	Shield-Belt	14	104-8300	3	Nut-HF, NI
1:2	93-7814	1	Decal-Danger	15	LDB14200-01	1	Support-Deck
1:3	105-0628	1	Decal-Caution, U-Joint	16	323-8	3	Screw-HH
1:4	105-0627	1	Decal-Caution	17	322-5	1	Screw-HH
2	105-0714	1	Hitch ASM	18	LDB13200-01	1	Mount-Idler
2:2	105-0698	1	Decal-Caution	19	105-4787-01	1	Stabilizer-Tensioner
3	99-5107	4	Nut-Lock	20	104-8301	4	Nut-HF, NI
5	325-6	4	Screw-HH	21	3231-2	1	Bolt-CARR
6	105-0686	1	Shield-Lower	22	106-0334	1	Idler Tensioner ASM
6:2	93-7814	1	Decal-Danger	22:1		1	Tensioner-Idler, Modified ●
7	106-0361	1	Bushing-Pulley	22:1:1		1	Tensioner-Idler ●
7:1	325-11	3	Screw-HH	22:1:1:1	33116-040	1	Screw-HH
7:2	3253-7	3	Washer-Lock	22:1:1:2	3253-7	1	Washer-Lock
8	106-0356	1	Pulley	22:2	105-0668	1	Decal-Align
9	41-004-5241	1	Key	22:3	105-0669	1	Decal-Angle
10	LDB12100	1	Shaft-Input	23	3214-15	1	Screw-HH
11	LDB15700-01	1	Stabilizer-Shield	24	105-4821	1	Idler-Pulley
13	3256-23	1	Washer-Plain	25	3220-6	1	Nut-Jam

● Not serviced separately

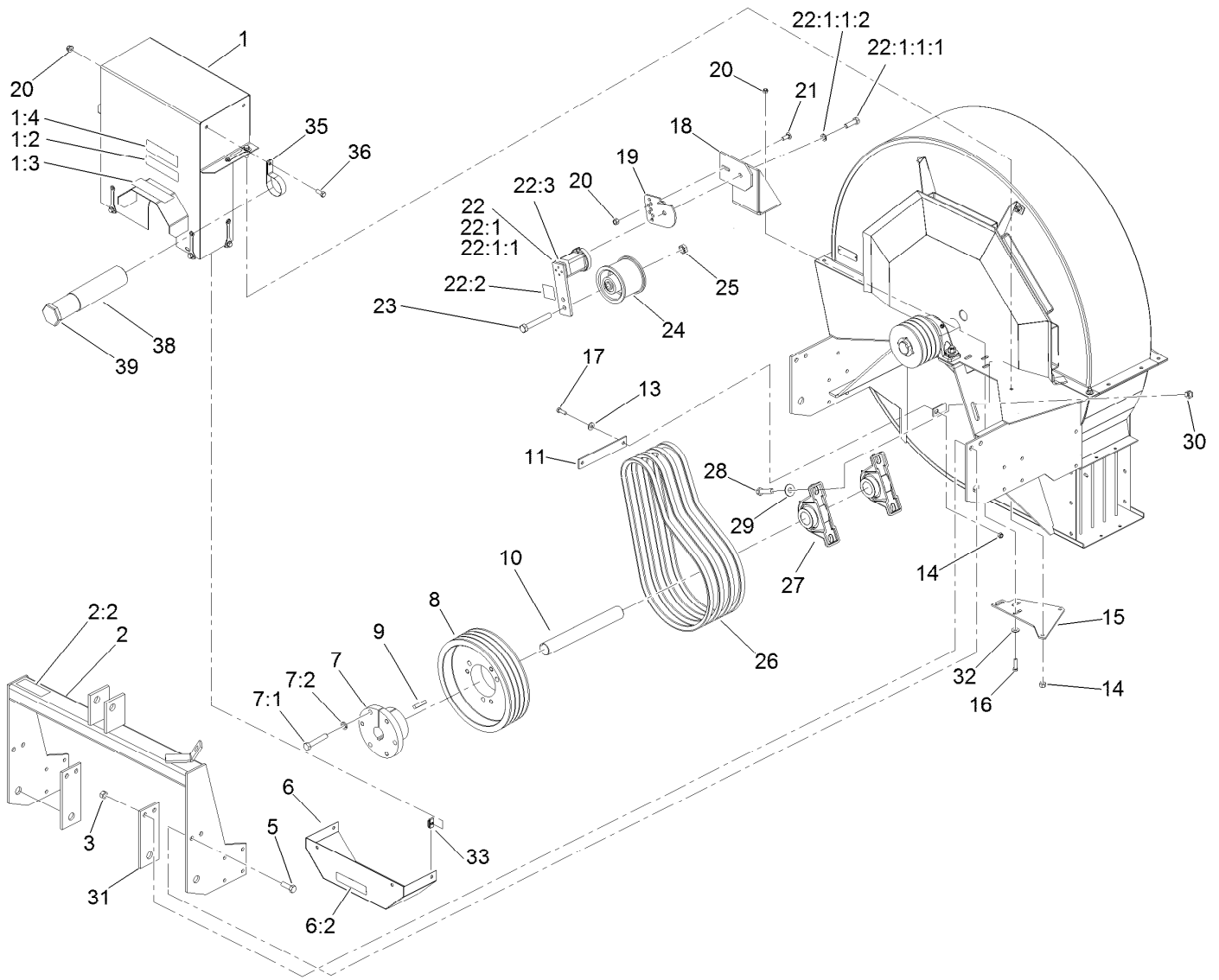

## Drive Assembly (continued)

<i>Ref.</i>	<i>Part Number</i>	<i>Qty.</i>	<i>Description</i>	<i>Ref.</i>	<i>Part Number</i>	<i>Qty.</i>	<i>Description</i>
26	LDB13000	4	V-Belt	32	3256-4	2	Washer-Flat
27	105-0621	2	Bearing-Block, Pillow	33	94-2413	4	Nut-U
28	325-9	4	Screw-HH	35	2412-133	2	Clamp-R
29	3256-6	4	Washer-Flat	36	323-5	2	Screw-HH
30	99-5107	4	Nut-Lock	38	104-7050	1	Tube-Manual
31	LDB10300-01	2	Stiffener-Hitch	39	104-7048	1	Cap-Housing

● Not serviced separately

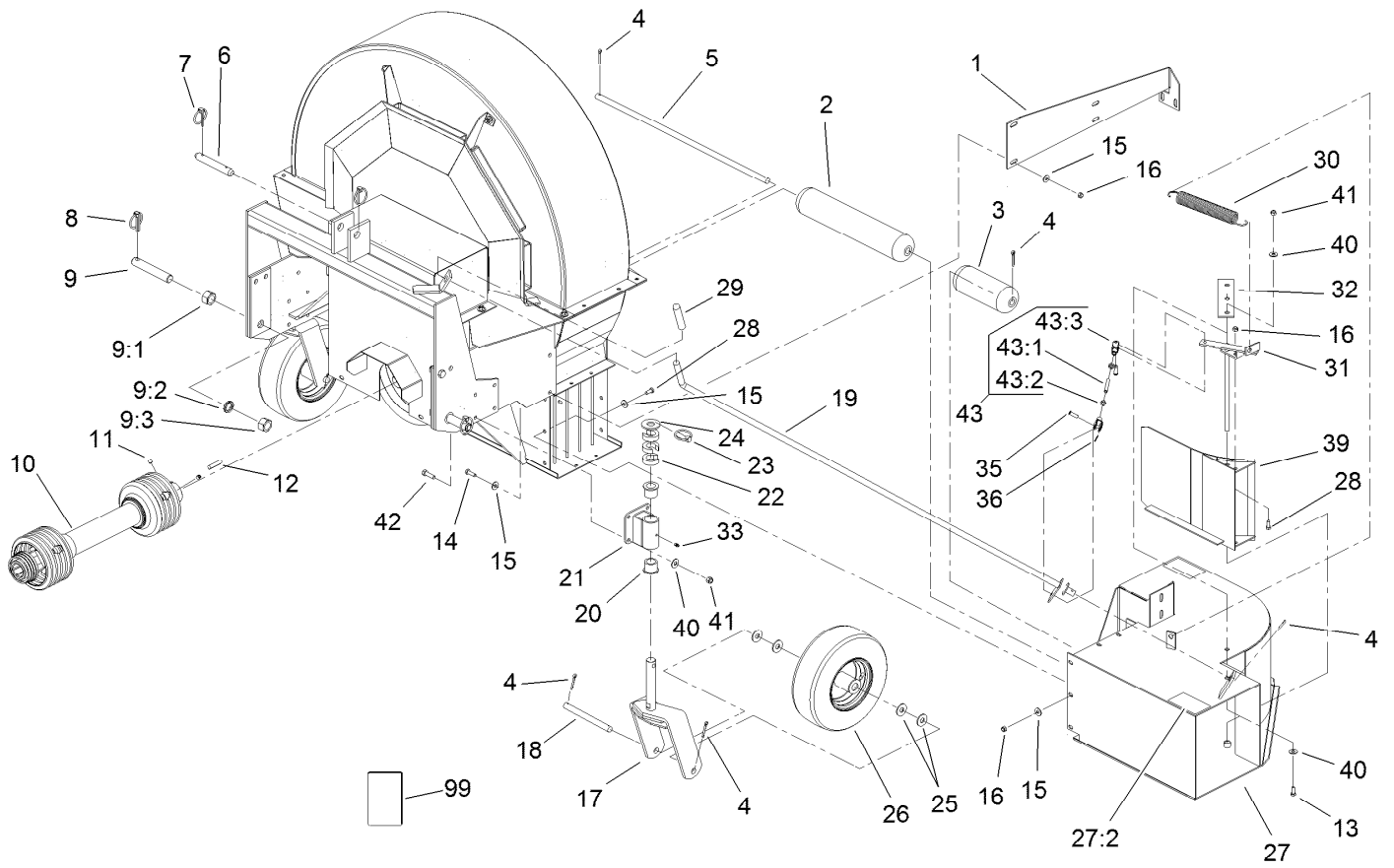

## Chute and Roller Assembly

Ref.	Part Number	Qty.	Description
1	LDB11600-01	1	Brace-Discharge, Back
2	105-4823	1	Roller-Turf
3	LDB13300	1	Roller-Turf, Short
4	3272-22	7	Pin-Cotter
5	LDB13500	1	Axle-Roller
6	92-1233	1	Pin-Clevis
7	92-1298	2	Pin-Lynch
8	283-71	2	Pin-Lynch
9	01-252-0010	2	Lift Arm Pin Adjustment ASM
9:1	3220-8	1	Nut-Jam
9:2	3253-28	1	Washer-Lock/Sp
9:3	3219-8	1	Nut-Hex
10	105-4924	1	Driveshaft ASM
11	3247-2	2	Screw-Set, HSH
12	41-004-5241	1	Key
13	323-6	2	Screw-HH
14	322-5	6	Screw-HH
15	3256-23	32	Washer-Plain
16	3296-29	17	Nut-Lock, NI
17	LDB10900-01	2	Caster-Fork

Ref.	Part Number	Qty.	Description
18	LDB11000	2	Axle-Wheel, Caster
19	LDB10700-01	1	Handle-Diverter
20	LDB11103	4	Bushing-Flange
21	LDB11100-01	2	Mount-Caster
22	LDB12600	6	Spacer-Sloted
23	283-71	2	Pin-Lynch
24	3256-62	2	Washer-Flat
25	3256-7	8	Washer-Flat
26	LDB12500	2	Castor Wheel ASM
27	105-0688	1	Discharge-Chute
27:2	105-0708	2	Decal-Danger
28	322-3	13	Screw-HH
29	PT503-00	1	Cover-Handle
30	105-4825	1	Spring
31	LDB10600-01	1	Pivot-Diverter
32	LDB10800-01	1	Plate-Top, Pin
33	302-5	2	Fitting-Grease
35	283-1	2	Pin-Clevis
36	3272-10	2	Pin-Cotter
39	LDB11800-01	1	Gate ASM
40	3256-24	12	Washer-Flat

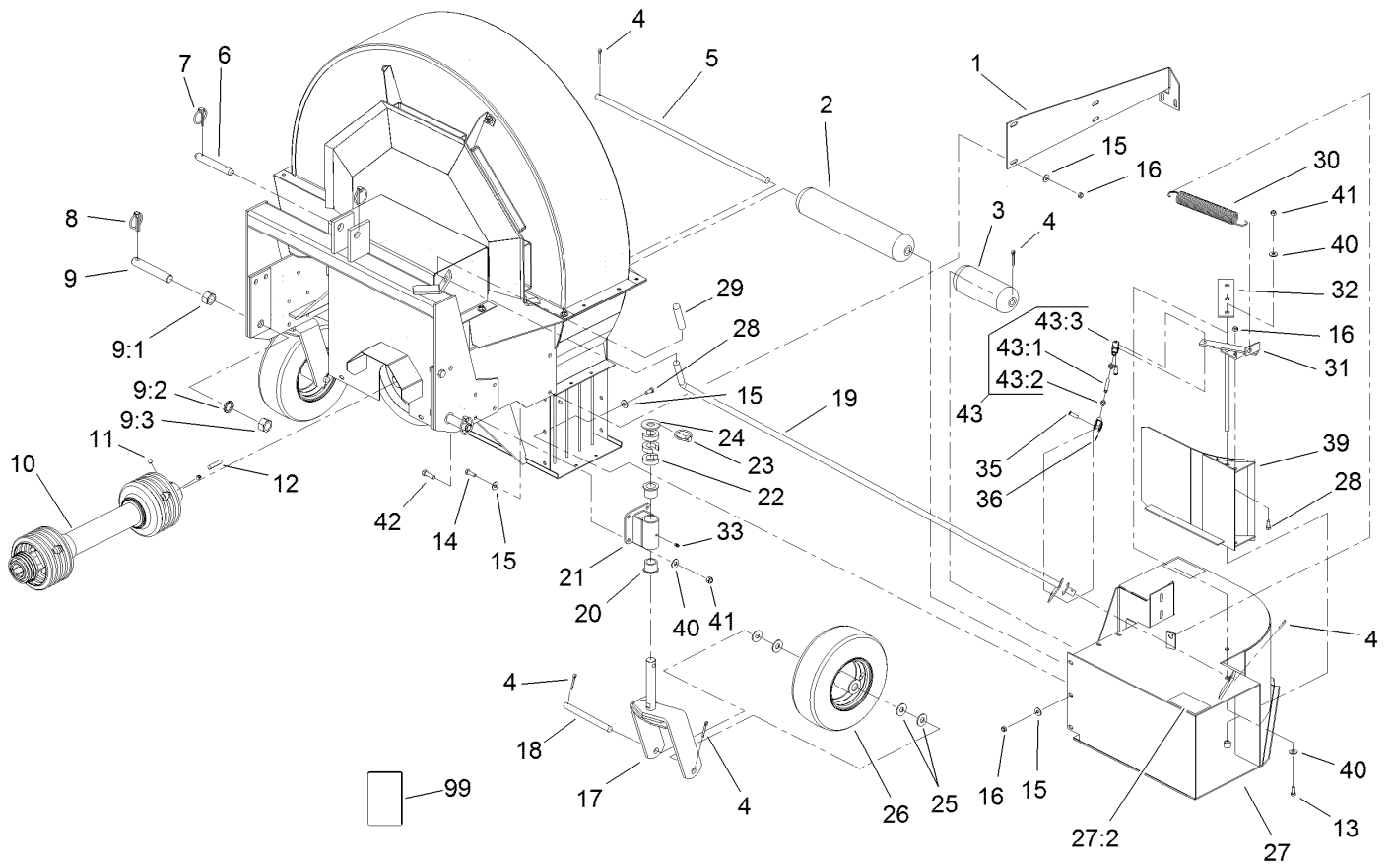

## Chute and Roller Assembly (continued)

<i>Ref.</i>	<i>Part Number</i>	<i>Qty.</i>	<i>Description</i>	<i>Ref.</i>	<i>Part Number</i>	<i>Qty.</i>	<i>Description</i>
41	3296-39	10	Nut-Lock, NI	43:2	3220-2	2	Nut-Jam
42	323-7	8	Screw-HH	43:3	1-303105	2	Yoke-Adjustable
43	115-6678	1	Chute Lever ASM	99	138-9038	1	Decal-Danger, Entanglement
43:1	LDB14400	1	Rod-Threaded				



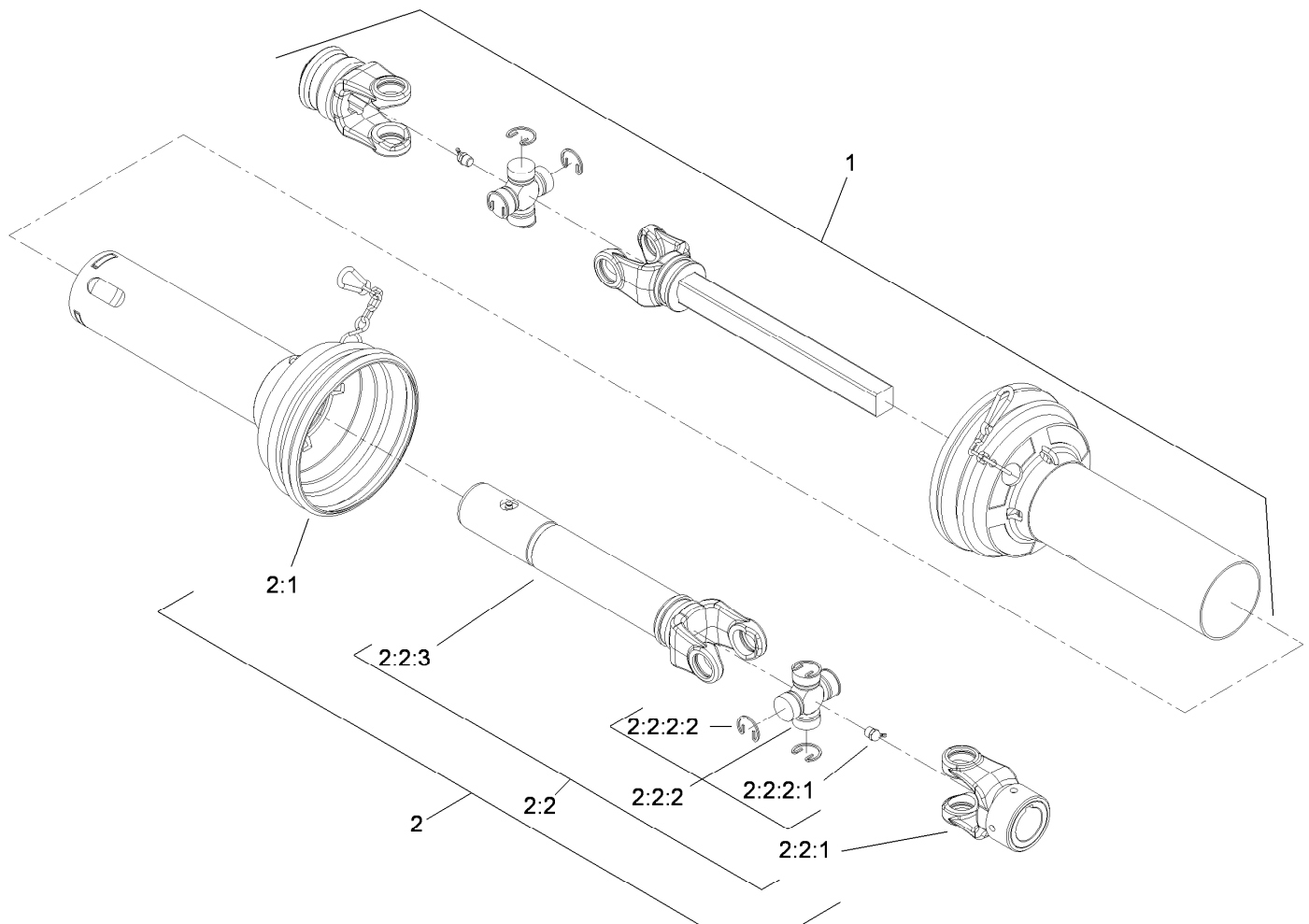

## Drive Shaft Assembly No. 105-4924

<i>Ref.</i>	<i>Part Number</i>	<i>Qty.</i>	<i>Description</i>
1	107-1144	1	Joint And Shaft Half ASM
2	107-1146	1	Joint And Tube Half ASM
2:1	107-1155	1	Inner Guard
2:2	107-1147	1	Joint And Tube Half ASM
2:2:1	107-1158	1	Yoke
2:2:2	72-7990	1	Cross And Bearing Kit
2:2:2:1	302-10	1	Fitting-Grease
2:2:2:2	107-1161	4	Clip Retaining
2:2:3	107-1157	1	Yoke, Tube And Slip Sleeve ASM

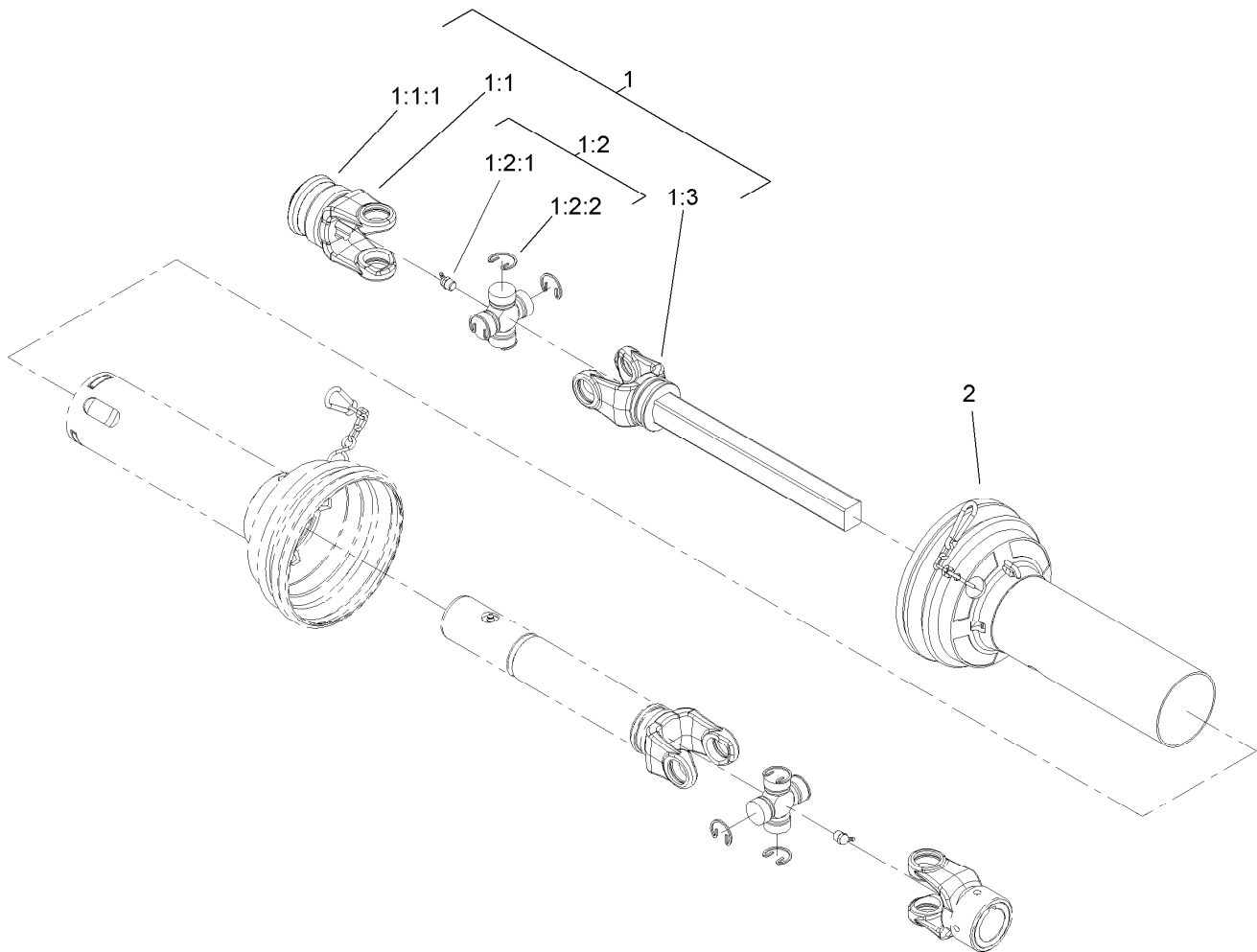

## Joint, Shaft and Guard Assembly No. 107-1144

<i>Ref.</i>	<i>Part Number</i>	<i>Qty.</i>	<i>Description</i>
1	107-1145	1	Joint And Shaft Half ASM
1:1	107-1148	1	Yoke-Spring Lock ASM
1:1:1	99-4477	1	Yoke Spring Lock Repair Kit
1:2	72-7990	1	Cross And Bearing Kit
1:2:1	302-10	1	Fitting-Grease
1:2:2	107-1161	4	Clip Retaining
1:3	107-1149	1	Yoke And Shaft
2	107-1154	1	Outer Guard

**Notes:**



**Count on it.**