



Wheel Horse®

44" Side Discharge Mower

for 5xi Lawn and Garden Tractors

Model No. 78444 – 8900001 & Up

Operator's Manual

IMPORTANT: Read this manual, and **your tractor manual**, carefully. They contain information about your safety and the safety of others. Also become familiar with the controls and their proper use before you operate the product.

Introduction

We want you to be completely satisfied with your new product, so feel free to contact your local Authorized Service Dealer for help with service, genuine replacement parts, or other information you may require.

Whenever you contact your Authorized Service Dealer or the factory, always know the model and serial numbers of your product. These numbers will help the Service Dealer or Service Representative provide exact information about your specific product. You will find the model and serial number plate located in a unique place on the product as shown below.

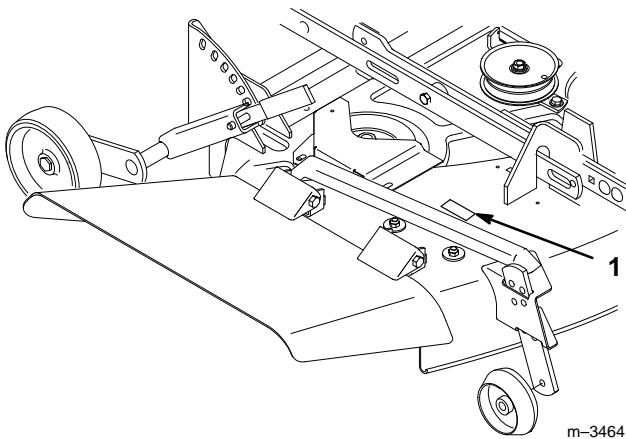

1. Model and Serial Number Plate

For your convenience, write the product model and serial numbers in the space below.

Model No: _____
Serial No. _____

The warning system in this manual identifies potential hazards and has special safety messages that help you and others avoid personal injury, even death. DANGER, WARNING and CAUTION are signal words used to identify the level of hazard. However, regardless of the hazard, be extremely careful.

DANGER signals an extreme hazard that will cause serious injury or death if the recommended precautions are not followed.

WARNING signals a hazard that may cause serious injury or death if the recommended precautions are not followed.

CAUTION signals a hazard that may cause minor or moderate injury if the recommended precautions are not followed.

Two other words are also used to highlight information. “Important” calls attention to special mechanical information and “Note” emphasizes general information worthy of special attention.

The left and right side of the machine is determined by sitting on the seat in the normal operator’s position.

Contents

	Page		Page
Safety and Instruction Decals	2	Maintenance	19
Installation	3	Service Interval Chart	19
Loose Parts	3	Cutting Blade	20
Mower Preparation	3	Greasing and Lubrication	21
Installing the Mower	4	Checking PTO Drive Belt Tension	22
Attach the PTO Drive Belt	6	Extending PTO Drive Belt Life	22
Adjusting the Mower	8	Blade Drive Belt	23
Removing the Mower	11	Washing the Underside of the Mower	23
Operation	14	Storage	24
Side Discharge	14	Troubleshooting	25
Operating the Power Take Off (PTO)	14		
Attachment Lift Lever	15		
Adjusting Anti-Scalp Rollers	16		
Adjusting the Two Front Wheels	16		
Check for Debris	17		
Tips for Mowing Grass	17		

Safety and Instruction Decals



Safety decals and instructions are easily visible to the operator and are located near any area of potential danger. Replace any decal that is damaged or lost.

ON GRASS DEFLECTOR
(Part No. 93-7316)

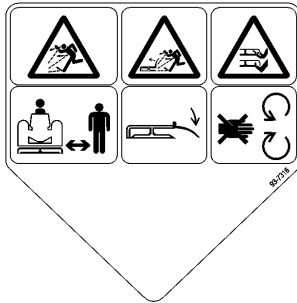

(1) ON GRASS DEFLECTOR
(1) ON DECK LEFT SIDE
(Part No. 93-7317)

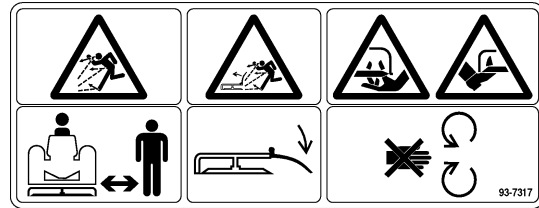

NEXT TO GAGE WHEELS
(Part No. 93-7282)

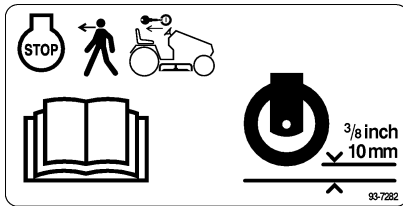

ON MOWER REAR TOP
(Part No. 98-3489)

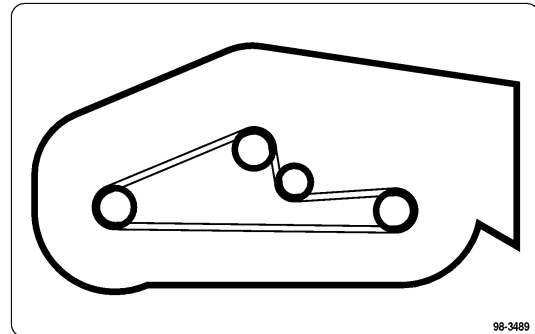

(2) ON LEVELER BAR
(Part No. 93-9367)

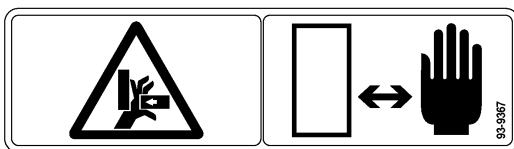

UNDER GRASS DEFLECTOR
(Part No. 93-7009)

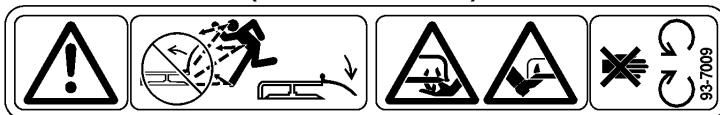

ON MOWER RIGHT SIDE
(Part No. 98-3481)

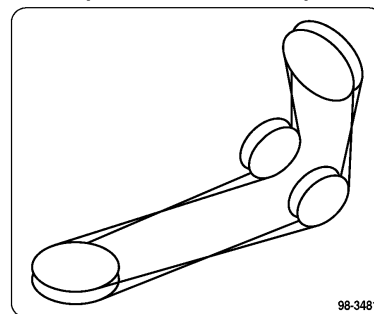

Installation

Loose Parts

Note: Use the chart below to identify parts used for assembly.

DESCRIPTION	QTY.	USE
Discharge chute	1	Install discharge chute
Spring	2	
Bolt 3/8–24 x 3–1/2"	2	
Lock nut 3/8"	2	
PTO drive belt	1	Install PTO drive belt
Pulley box	1	Install pulley box
Operator's Manual	1	Read before operating

Mower Preparation

Install the Discharge Chute

1. Place the springs into the brackets on the mower with the hooked ends over the raised back of the bracket (Fig. 1).
2. Align the discharge chute with the holes in the brackets and the spring straight ends in the space under the hinge and above the chute (Fig. 1).
3. Secure the chute to the bracket with bolts through the discharge chute, springs and brackets. Secure with lock nuts (Fig. 1).
4. Lift the discharge chute and check that it is spring loaded and pivots freely to the full down position.

IMPORTANT: Discharge chute must be spring loaded in the down position. Lift the chute up to test that it snaps to the full down position.

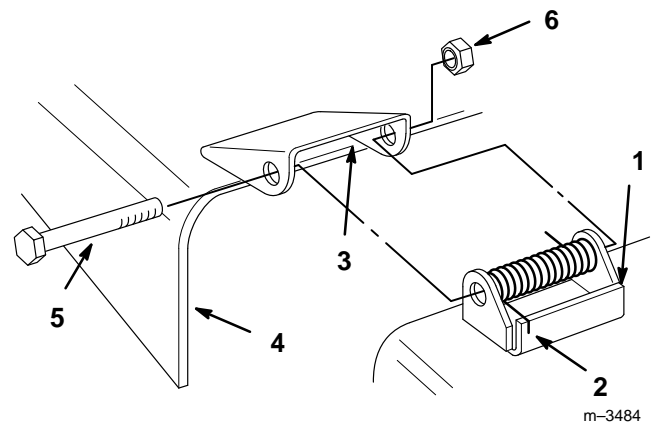

Figure 1

- | | |
|---------------------|--------------------|
| 1. Bracket | 4. Discharge chute |
| 2. Spring hook end | 5. Bolt |
| 3. Space for spring | 6. Lock nut |

⚠ DANGER

POTENTIAL HAZARD

- Without the discharge chute or the complete grass catcher assembly mounted in place, you and others are exposed to blade contact and thrown debris.

WHAT CAN HAPPEN

- Contact with rotating mower blade(s) and thrown debris will cause injury or death.

HOW TO AVOID THE HAZARD

- NEVER remove the discharge chute from the mower because the discharge chute routes material down toward the turf. If the discharge chute is ever damaged, replace it immediately. Never put your hands or feet under the mower.
- Never try to clear the discharge area or mower blades unless you move the power take off (PTO) to “OFF” and turn the ignition key to “STOP.” Also remove the ignition key and pull the wire(s) off the spark plug(s).

Mower Belt Routing

1. Route the mower belt as shown in Fig. 2. Be sure to install the belt on the lower mower deck pulley.

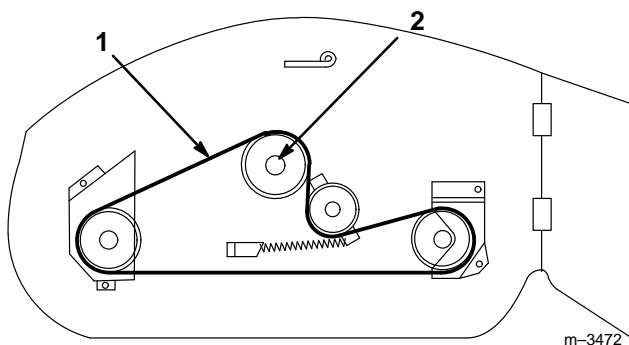

Figure 2

Top View

1. Mower belt
2. Mower deck pulley

Installing the Mower

Initial Preparation

The mower is most easily installed when done on a level concrete surface. Rougher dirt or lawn surfaces make installation more difficult.

1. Position the tractor and mower side by side, with the mower on the right-hand side of the tractor.
2. Set the parking brake, raise the attachment lift, and turn the ignition key to “STOP” to stop the engine. Remove the ignition key.
3. If you have previously had a snowthrower, blade or tiller attached to the attachment lift, remove the two clevis pins on each side of the attachment lift (Fig. 3).

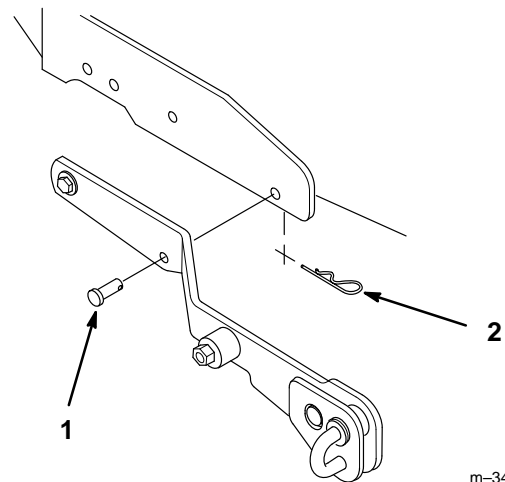

Figure 3

1. Clevis pin
2. Hairpin cotter

4. Attach the pulley box if it is not already on the tractor. Make sure the latches on the tractor’s front Attach-A-Matic™ are open (Fig. 4). Then slide the pulley box into the Attach-A-Matic™ latches and seat it. Close the latches.

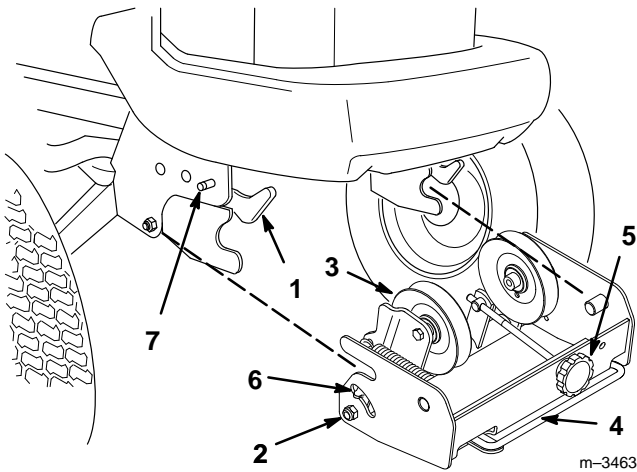

Figure 4

- | | |
|-----------------------------|---|
| 1. Attach-A-Matic™ latches | 5. Belt tension adjustment knob |
| 2. Pulley box | 6. Belt tension indicators (one on each side) |
| 3. Idler pulley | 7. Attach-A-Matic™ button |
| 4. Belt tension release arm | |

Attach the Mower

1. Make sure the mower wheels are set for low height of cut.
2. Make sure the attachment lift is in the full up position.
3. From the driver's right-hand side of the tractor, slide the mower under the tractor.
4. After sliding the mower under the tractor, position it so that the slots in the side of each of the mower's mounting brackets (Fig. 5) are aligned directly below the tractor's attachment lift arm.

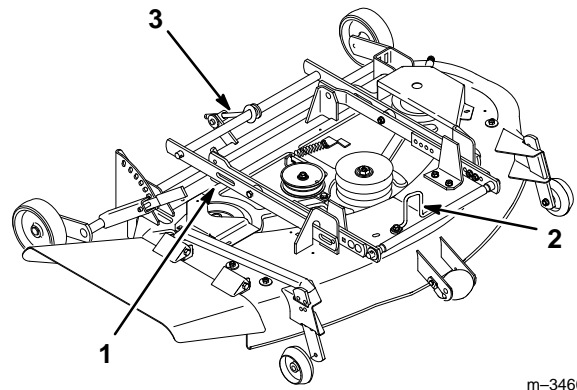

Figure 5

- | | |
|--|---------------------------------|
| 1. Slots in the side mounting brackets (2) | 3. Front-to-rear adjustment rod |
| 2. Belt guide | |

5. Start the tractor.
6. Lower the attachment lift arm fully and adjust the deck's position until you can pull out the J-pin of the lift arm and slide it into the slot in the mounting bracket of the mower (Fig. 6).
7. On the driver's left-hand side, pull out the attachment lift J-pin and slide it into the slot on the other mower mounting bracket.

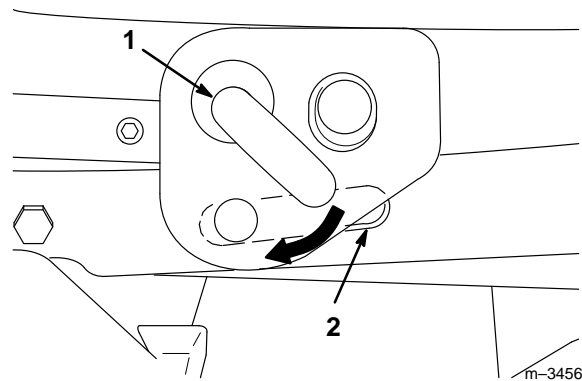

Figure 6

Left Side of Tractor Shown

- | | |
|----------|---|
| 1. J-pin | 2. Mower slot in side mounting bracket. |
|----------|---|

- After the two J-pins are seated through the mower's mounting brackets, using the attachment lift and your hand on the right front adjustable mower wheel bracket (Fig. 7), position the mower so its attachment bar fits into the mid Attach-A-Matic™ mount.

! WARNING

POTENTIAL HAZARD

- The “scissor” formed by the mower mounting brackets and the attachment lift arm is dangerous.

WHAT CAN HAPPEN

- Hands and fingers can get caught between the mower parts and the tractor and be injured.

HOW TO AVOID THE HAZARD

- Keep hands away from moving parts while operating the attachment lift.
- Always position the mower with your hand on the right front mower wheel bracket.
- Never try to position the mower with your hands on the mower mounting brackets or below the mower housing.

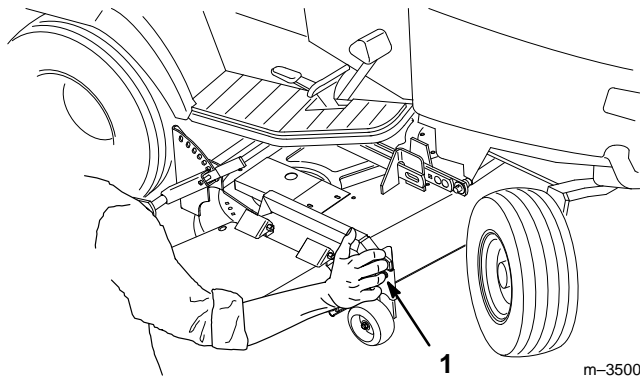

Figure 7

- Place hand here

- Turn the lever of the Attach-A-Matic™ counterclockwise to lock the mower to the tractor (Fig. 8).

- Set the parking brake, lower the attachment lift, and turn the ignition key to “STOP” to stop the engine. Then remove the ignition key.

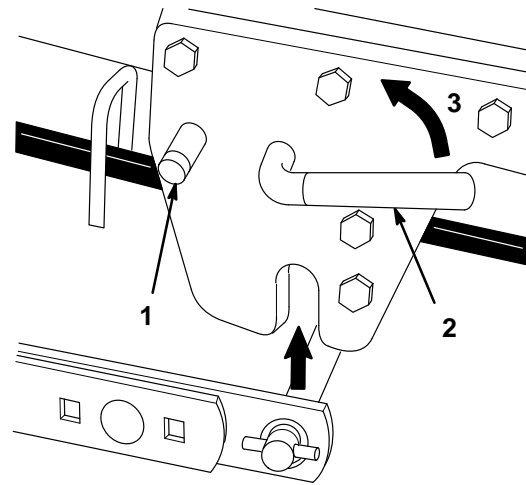

Figure 8

- Attach-A-Matic™ button
- Attach-A-Matic™ lever
- Lock

Attach the PTO Drive Belt

- Hang the belt over the mower, then thread it forward through the belt guide (Fig. 9) on the mower.

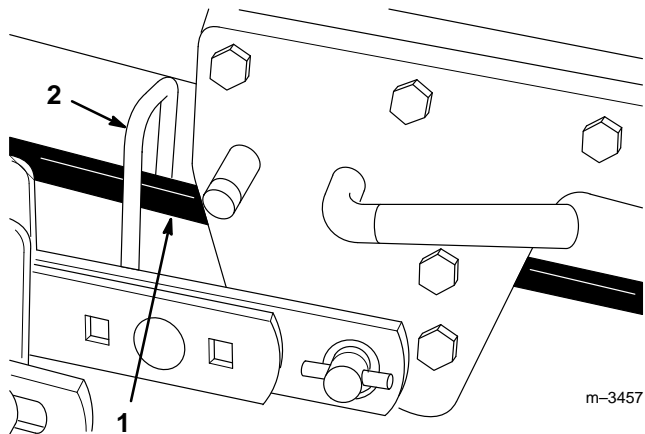

Figure 9

- Belt
- Belt guide

- Extend the belt through the center of the pulley box, between the two pulleys.

3. Release the belt tension release arm on the pulley box housing and swing it out toward you (Fig. 13).
4. Remove the tractor's front grill by raising the hood and unscrewing the two screws and washers securing it in place (Fig. 10). Close the hood and remove the grill by pulling it out toward you.

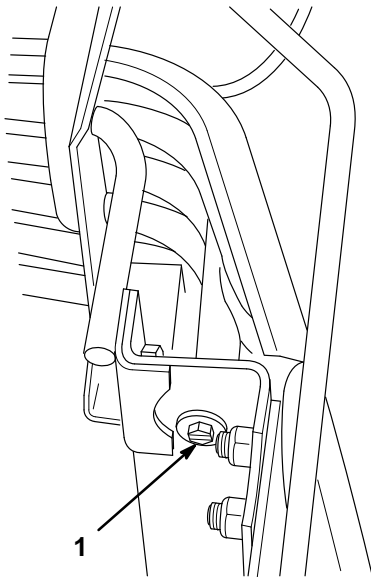

Figure 10

m-3558

1. Grill screw (1 of 2)

CAUTION

POTENTIAL HAZARD

- Components under the hood will be hot if the tractor has been running.

WHAT CAN HAPPEN

- Touching hot components can cause burns.

HOW TO AVOID THE HAZARD

- Allow the tractor to cool before performing maintenance or touching components under the hood.

5. Position the belt into the grooves of the PTO pulley (Fig. 11), making sure it is also under the pulleys in the pulley box.

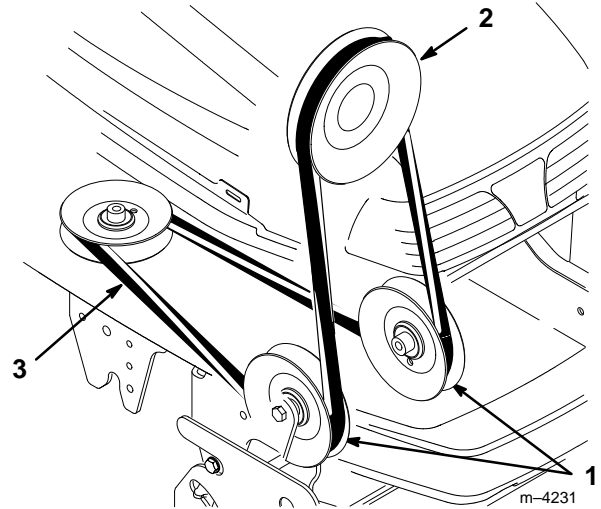

Figure 11

1. Pulley box pulley
2. PTO pulley
3. PTO drive belt

6. Loop the other end of the belt over the drive pulley of the mower. Additional belt slack can be obtained (if needed) by turning the belt tension adjustment knob (Fig. 13).
7. Make certain that the wide side of the PTO drive belt is toward the outside diameter of **all (four) pulleys (Fig. 12).**

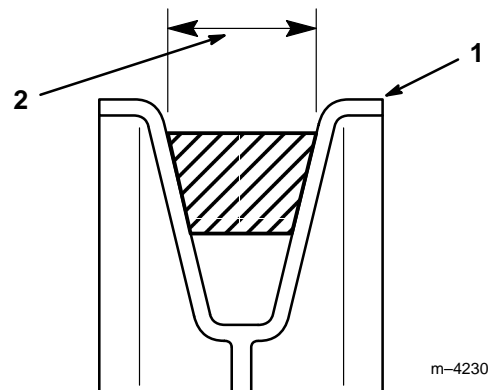

Figure 12

1. Pulley outside diameter
2. Wide side of belt

8. Now adjust the belt tension.
 - A. Push the belt tension release arm back toward the pulley box to tension the belt.

- B. Check the tension indicators on each side of the pulley box.
- C. If the tension indicators are not in the same position on both the left and right sides, release the belt tension, turn the adjustment knob and repeat steps A and B until the indicators move to the same position (Fig. 13).
- D. Once the indicators are in the same position on both sides, swing the tension release arm into the pulley box and seat it by moving it into the position shown in Figure 13.

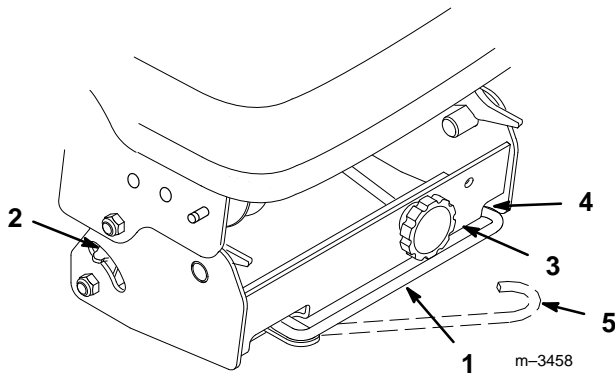

Figure 13

- | | |
|---------------------------------|-------------------------------------|
| 1. Belt tension release arm | 4. Seating position for tension arm |
| 2. Belt tension indicator (2) | 5. Belt tension released knob |
| 3. Belt tension adjustment knob | |

- 9. Loosen the belt guide bolt (Fig. 14).
- 10. Adjust the belt guide so that it just touches the belt on the inside arm of the guide, toward the center of the deck (Fig. 14).

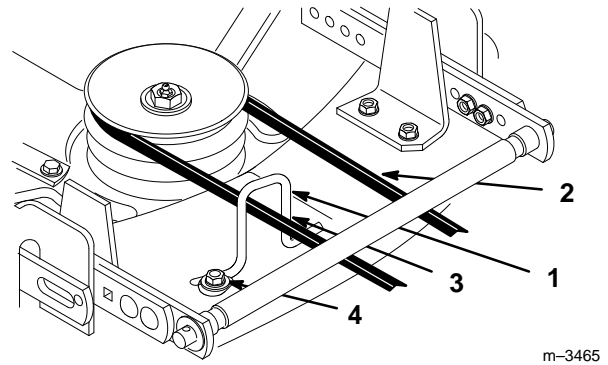

Figure 14

- | | |
|---------------|----------------------|
| 1. Belt guide | 3. Belt touches here |
| 2. Belt | 4. Belt guide bolt |

- 11. Tighten the belt guide bolt.
- 12. Replace the front grill of the tractor, securing it with two previously removed screws and washers (Fig. 10).

Adjusting the Mower

Adjusting the Height of Cut

The rear gauge wheels are adjusted in different hole locations for 1—4" (3–10 cm) heights of cut.

- 1. Start the tractor, apply the parking brake, and raise the deck. Get off the tractor. Pull the height-of-cut lever out to disengage it from the quadrant. Adjust the height of cut to the desired level. Release the lever inward to lock into the quadrant (Fig. 15).

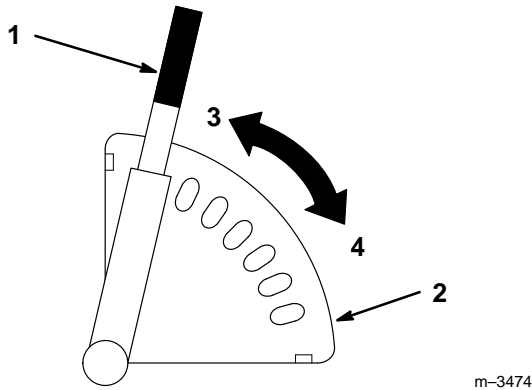

Figure 15

- | | |
|------------------------|---------|
| 1. Height-of-cut lever | 3. High |
| 2. Quadrant | 4. Low |

Checking Mower Level

For optimum efficiency, the level of the mower should be checked at the time of initial installation and periodically as a check, to ensure that the blades are 1/8" (3 mm) lower in the front than in the rear.

The mower must be checked and adjusted on a flat level surface, preferably concrete. Before checking the mower level, set the air pressure in the front and rear tires as specified in the tractor operator's manual. Place the mower height-of-cut lever to the middle cut position. Make sure the two adjustable front wheels are off the ground.

Adjusting Front-to-Rear Blade Cut

1. Disengage the power take off (PTO), set the parking brake, lower the attachment lift, and turn the ignition key to "STOP" to stop the engine. Remove the ignition key.
2. Carefully rotate one of the blades so it is facing front and rear (Fig. 16).
3. Measure the distance from the front tip of the blade (Fig. 16) to the flat surface. Then carefully rotate the blade tip until it is in the rear position. When the blade tip is in the front position, it should be 1/8" (3 mm) lower than when it is in the rear position.

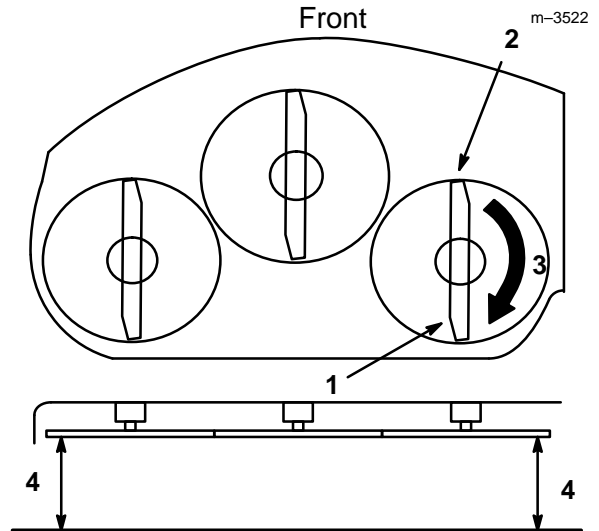

Figure 16

- | | |
|---|--------------------------------|
| 1. Blade oriented front to rear | 4. Measure here (side to side) |
| 2. Measure front blade tip | |
| 3. Rotate front tip to rear and measure | |

4. Front-to-rear adjustment is made by turning the adjusting nut (Fig. 17) on the back of the mower. To raise the front of the mower, turn the adjustment nut clockwise. To lower the front of the mower, turn the nut counterclockwise.

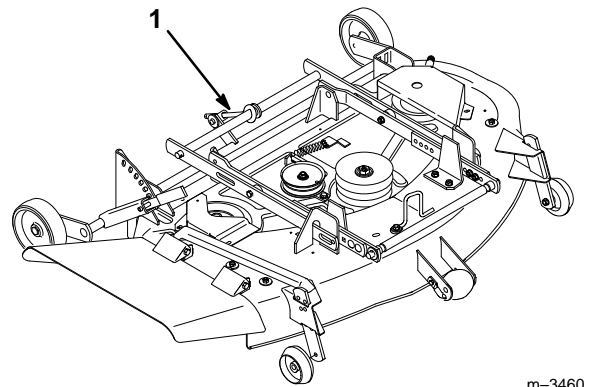

Figure 17

- | |
|---------------------------------|
| 1. Front-to-rear adjustment rod |
|---------------------------------|

Adjusting Side-to-Side Blade Cut

This optional adjustment is available if necessary to compensate for uneven side-to-side cut.

Equalize side-to-side cut by adjusting the two carriage bolts (Fig. 18) on the mower. Check height of blade at outside blade tips as shown (Fig. 16).

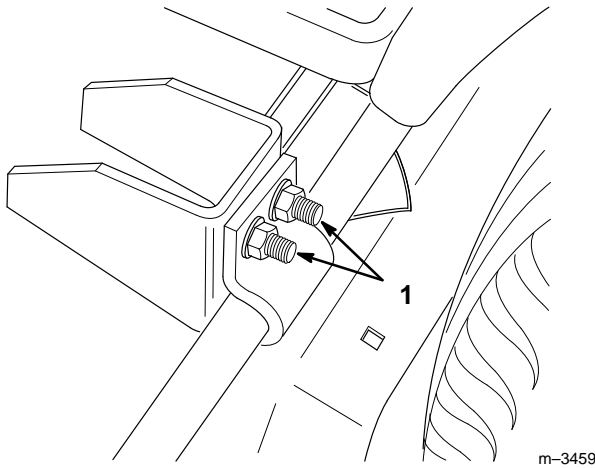

Figure 18

1. Side-to-side adjustment bolts

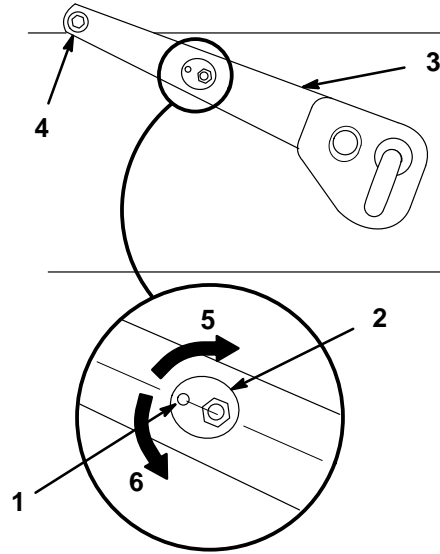

Figure 19

Right Side of Tractor Shown

1. Indicator
2. Adjustment cam
3. Lift arm
4. Pivot point
5. Lowers front of deck
6. Raises front of deck

Adjusting the Blade Slope for Transport

Because the attachment lift is used when the PTO drive is engaged, blade slope in transport must be adjusted to extend PTO drive belt life. This adjustment also provides for adequate transport height. Three steps accomplish this: 1) Making sure the lift arm cams are in the same position, 2) Measuring blade slope in its front and rear positions and 3) Making adjustments if the blade slope is not within specification.

IMPORTANT: Failure to adjust for blade slope in transport can result in drive belt failure and/or insufficient transport height.

1. Check to see that both adjustment cams are oriented with the indicator toward the pivot point at the rear of the tractor (Fig. 19).

2. If they are not, park the machine on a level surface, set the parking brake, lower the attachment lift to take pressure off the cams, and turn the ignition key to "STOP" to stop the engine. Remove the ignition key.

 **WARNING**
POTENTIAL HAZARD

- The “scissor” formed by the mower mounting brackets and the attachment lift arm is dangerous.

WHAT CAN HAPPEN

- Hands and fingers can get caught between the mower parts and the tractor and be injured.

HOW TO AVOID THE HAZARD

- Keep hands away from moving parts while operating the attachment lift.
- Set the parking brake, lower the attachment lift, turn the ignition key to “STOP” to stop the engine, and remove the ignition key before making any adjustments.

- Loosen the nuts on the cams, rotate the cams to the proper position, then tighten the cam nuts.
- Start the tractor, raise the attachment lift and turn the ignition key to “STOP” to stop the engine. Remove the ignition key.
- Check the slope of one of the blades (Fig. 16).
 - Measure the distance from the front tip of the blade to the flat surface.
 - Carefully rotate the blade tip until it is in the rear position.
 - When the blade tip is in the front position, it should be approximately 1/4” (7 mm) lower than when it is in the rear position.
- If it is not, start the tractor, lower the attachment lift to take pressure off the cams, and turn the ignition key to “STOP” to stop the engine. Remove the ignition key.
- Loosen the cam nuts and equally rotate the left-hand and right-hand cams down to raise the front of the deck, or up to lower the front of the deck. Tighten the nuts.
- Repeat steps 4–7 until the slope of the blade is approximately 1/4” (7 mm) lower in the front than it is in the rear.

Removing the Mower

The mower is most easily removed from the tractor when done on a level concrete surface. Rougher dirt or lawn surfaces make removing the mower more difficult.

- Apply the parking brake, start the tractor, and raise the attachment lift.
- Get off the tractor. Place the mower height-of-cut lever in the lowest cut position.
- Lower the deck until its weight is completely on its wheels, not on the tractor.
- Turn the ignition key to “STOP” to stop the engine. Remove the ignition key.
- Remove the tractor’s front grill by raising the hood and unscrewing the two screws and washers securing it in place (Fig. 10). Close the hood and remove the grill by pulling it out toward you.

 **CAUTION**
POTENTIAL HAZARD

- Components under the hood will be hot if the tractor has been running.

WHAT CAN HAPPEN

- Touching hot components can cause burns.

HOW TO AVOID THE HAZARD

- Allow the tractor to cool before performing maintenance or touching components under the hood.

- Release the belt tension release arm on the pulley box to release the tension on the drive belt (Fig. 20).

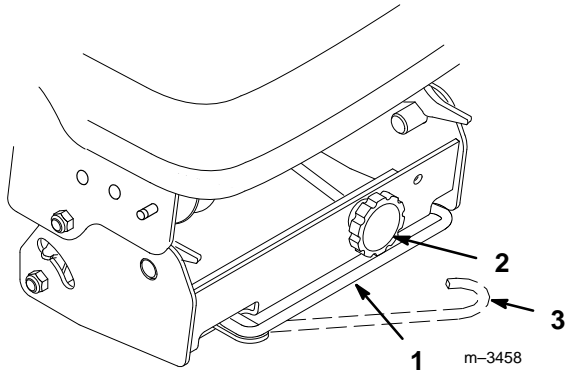

Figure 20

- 1. Belt tension release arm
- 2. Belt tension adjustment knob
- 3. Belt tension released

- 7. Remove the belt from around the PTO pulley (Fig. 21). Additional belt slack can be obtained (if needed) by turning the belt tension adjustment knob.

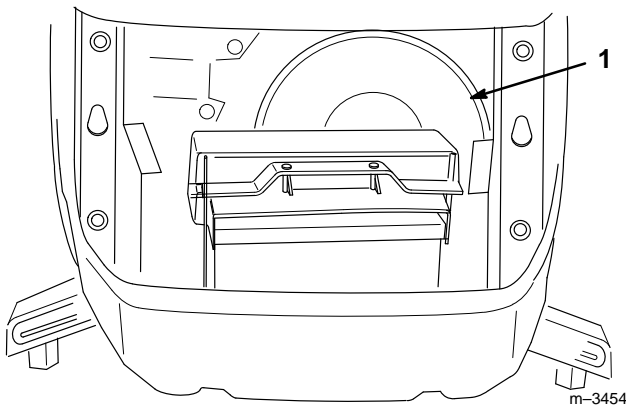

Figure 21

- 1. PTO pulley

- 8. Replace the front grill of the tractor, securing it with two previously removed screws and washers (Fig. 10).

- 9. Press the button of the mid Attach-A-Matic™ and twist the lever clockwise to release the mower (Fig. 22).

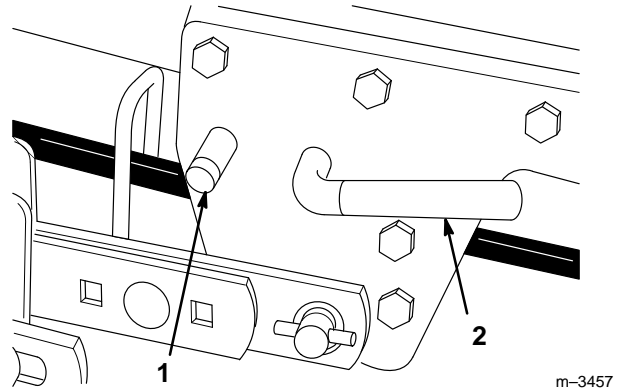

Figure 22

- 1. Mid Attach-A-Matic™ button
- 2. Mid Attach-A-Matic™ lever

- 10. Pull the two spring-loaded J-pins from the deck lift arms and twist them slightly so that they stay disengaged (Fig. 23).

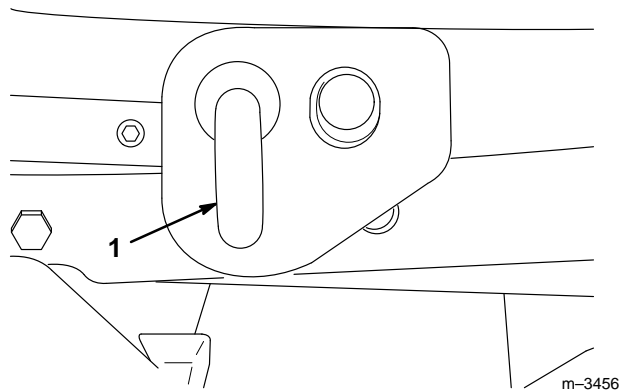

Figure 23

- 1. J-pin

11. If you wish to remove the pulley box, push the latch release buttons on the front Attach-A-Matic™ (Fig. 24) and raise the latch levers to open the latches holding the pulley box. Remove the pulley box.

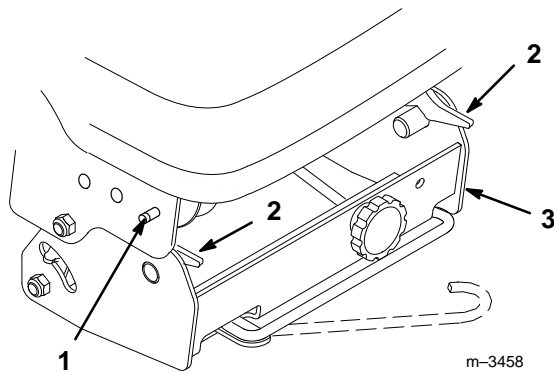

Figure 24

1. Front Attach-A-Matic™ button (one on each side)
2. Front Attach-A-Matic™ latches
3. Pulley box

12. Start the tractor and raise the attachment lift to provide ample clearance to slide out the mower. Then turn the ignition key to “STOP” to stop the engine. Remove the ignition key.
13. Slide the mower out from the driver’s right-hand side of the tractor.

Operation

Side Discharge

The mower has a hinged grass deflector that disperses clippings to the side and down toward the turf.

DANGER

POTENTIAL HAZARD

- Without the discharge chute or complete grass catcher assembly mounted in place, you and others are exposed to blade contact and thrown debris.

WHAT CAN HAPPEN

- Contact with rotating mower blade(s) and thrown debris will cause injury or death.

HOW TO AVOID THE HAZARD

- NEVER remove the discharge chute from the mower because the discharge chute routes material down toward the turf. If the discharge chute is ever damaged, replace it immediately.
- Never put your hands or feet under the mower.
- Never try to clear the discharge area or mower blades unless you move the power take off (PTO) to “OFF” and rotate the ignition key to “STOP.” Also remove the ignition key and pull the wire(s) off the spark plug(s).

Operating the Power Take Off (PTO)

The power take off (PTO) engages and disengages power to the electric clutch.

While the ignition key is in RUN or LIGHTS position and the power take off (PTO) is engaged, the PTO indicator light will be on. When this light is ON, it is a reminder: the implement is being powered and the starter will not crank while the PTO is engaged. Always turn off the PTO before getting off the seat.

Engaging the Power Take Off (PTO)

1. Depress the brake pedal to stop the machine.
2. Move the throttle lever to FAST.

IMPORTANT: For best performance, always use full throttle when the power take off (PTO) switch is ON.

3. Pull the power take off (PTO) switch to ON (Fig. 25).

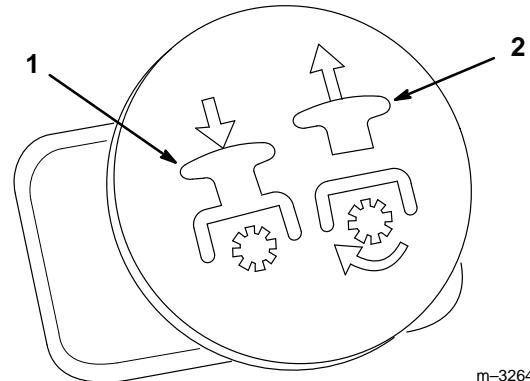

m-3264

Figure 25

1. Push (off-disengaged)
2. Pull (on-engaged)

Disengaging the Power Take Off (PTO)

1. Push the power take off (PTO) switch to OFF.

Attachment Lift Lever

The attachment lift lever (Fig. 26 & 27) is used to raise and lower various attachments.

Raising Attachments

1. Start the tractor.
2. Pull the attachment lift lever upward until the latch locks. In this position, the lift will hold the attachment in the up, or raised position.

WARNING

POTENTIAL HAZARD

- When the engine is off, attachments in the raised position can gradually lower.

WHAT CAN HAPPEN

- Someone nearby may be pinned or injured by the attachment as it lowers.

HOW TO AVOID THE HAZARD

- Always lower the attachment each time you shut off the tractor.

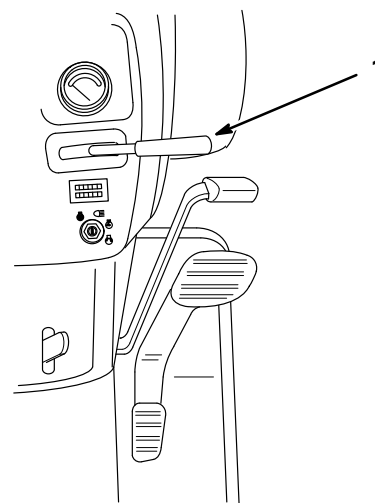

m-3258

Figure 26

1. Attachment lift lever

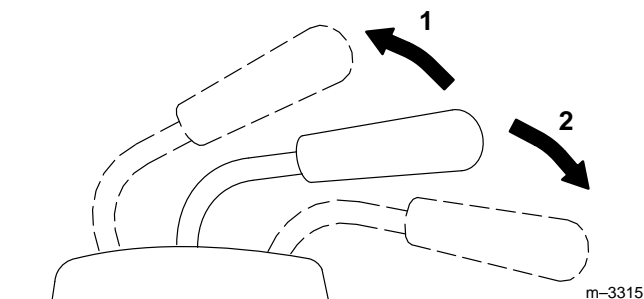

m-3315

Figure 27

1. Raise attachment
2. Lower attachment

Lowering Attachments

1. Start the tractor.
2. Push the attachment lift lever downward to lower the attachment.

Adjusting Anti-Scalp Rollers

The anti-scalp rollers guide the mower over uneven turf without scalping the lawn. For most cutting conditions they should be located in the lower hole. When cutting in 1-1/2" height-of-cut or lower move the anti-scalp rollers to the upper hole position.

1. Raise the attachment lift lever; refer to Raising Attachments.
2. Remove the cotter pin, bolt and shaft to change hole location (Fig. 28).
3. Select the hole position for the height-of-cut to be used and insert the rod (Fig. 28).
4. Secure the rod with the bolt and cotter pin.

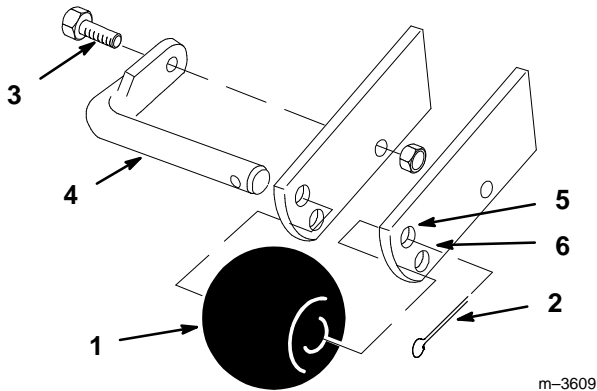

Figure 28

- | | |
|---------------|---------------|
| 1. Roller | 4. Rod |
| 2. Cotter pin | 5. Upper hole |
| 3. Bolt | 6. Lower hole |

Adjusting the Two Front Wheels

The two front adjustable wheels must be adjusted in the proper hole location for each time you change deck height-of-cut position.

1. After selecting height of cut, make sure the front adjustable wheels are approximately 3/8" (9.5 mm) off the ground.
2. To adjust wheel height off the ground, remove the hairpin cotter and pin to change hole location (Fig. 29).
3. Select a hole position so the wheel is approximately 3/8" (9.5 mm) off the ground for the height-of-cut position to be used (Fig. 29).
4. Insert the pin and secure it with a hairpin cotter.
5. Repeat this adjustment on the other wheel.

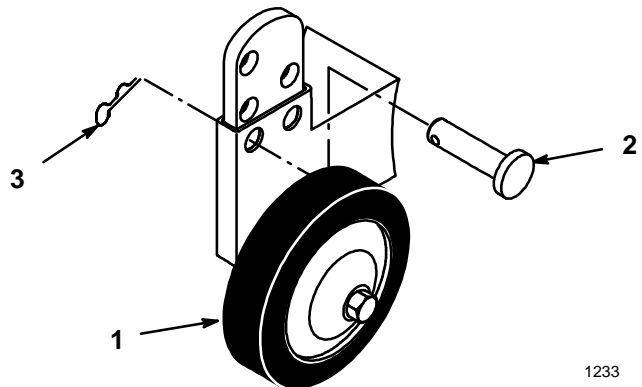

Figure 29

- | | |
|----------|--------------------|
| 1. Wheel | 3. Hair pin Cotter |
| 2. Pin | |

Check for Debris

Each time you use the mower, be sure to check for debris build up on and inside the rear transaxle cover (Fig. 30). Remove any build up.

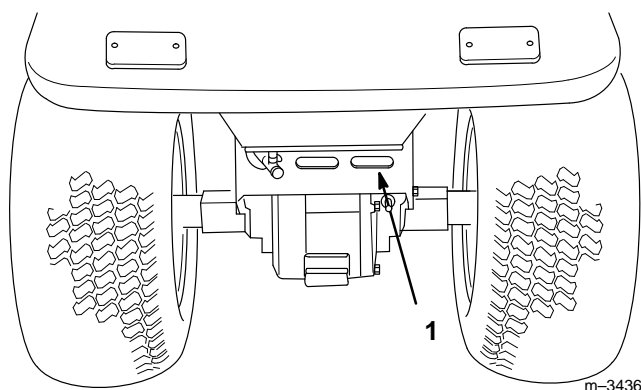

Figure 30

1. Rear transaxle cover

Tips for Mowing Grass

Fast Throttle Setting

For best mowing and maximum air circulation, operate the engine at “FAST.” Air is required to thoroughly cut grass clippings, so do not set the height-of-cut so low as to totally surround the mower by uncut grass. Always try to have one side of the mower free from uncut grass, which allows air to be drawn into the mower.

Using the Mower for the First Time

Cut grass slightly longer than normal to ensure the cutting height of the mower does not scalp any uneven ground. However, the cutting height used in the past is generally the best one to use. When cutting grass longer than six inches tall, you may want to cut the lawn twice to ensure an acceptable quality-of-cut.

Cut 1/3 of the Grass Blade

It is best to cut only about 1/3 of the grass blade. Cutting more than that is not recommended, unless grass is sparse or it is late fall when grass grows more slowly.

Mowing Direction

Alternate mowing direction to keep the grass standing straight. This also helps disperse clippings which enhances decomposition and fertilization. Avoid mowing in reverse.

Mow at Correct Intervals

Normally, mow every 4 days. But remember, grass grows at different rates at different times. So to maintain the same cutting height, which is a good practice, mow more often in early spring. As the grass growth rate slows in mid summer, mow less frequently. If you cannot mow for an extended period, first mow at a high cutting height; then mow again 2 days later at a lower height setting.

Ground Speed

To improve cut quality, use slower ground speed. For best operation on average lawns, operate engine at full throttle while controlling ground speed with transmission. Tractor should be operated at 2 to 3.5 MPH (3.2 to 5.6 kms/hr) while mowing grass. Uneven cutting is often a result of excessive ground speed. To correct, use low range with the high-low lever, or reduce ground speed in high range.

Avoid Cutting Too Low

If the cutting width of the mower is wider than the mower you previously used, raise the cutting height to ensure uneven turf is not cut too short. Average lawns are usually cut at a height between 2 and 3 inches (5–7.6 cm).

Long Grass

If the grass is ever allowed to grow slightly longer than normal, or if it contains a high degree of moisture, raise the cutting height higher than usual and cut the grass at this setting. Then cut the grass again using the lower, normal setting.

When Stopping

If the machine's forward motion must be stopped while mowing, a clump of grass clippings may drop onto your lawn. To avoid this:

1. With the blade(s) "ENGAGED," move onto a previously cut area.
2. To disperse the clippings evenly, raise the mower while driving forward with the blade(s) "ENGAGED."

Keep the Underside of the Mower Clean

Use the washout port to clean clippings and dirt from the underside of the mower after each use. If grass and dirt build up inside the mower, cutting quality will eventually become unsatisfactory.

Blade Maintenance

Maintain a sharp blade throughout the cutting season because a sharp blade cuts cleanly without tearing or shredding the grass blades. Tearing and shredding turns grass brown at the edges, which slows growth and increases the chance of disease. Every 30 days, check the cutter blade(s) for sharpness and file down any nicks.

Maintenance

Service Interval Chart

Service Operation	Each Use	5 Hours	25 Hours	50 Hours	Storage Service	Spring Service
Cutter Blade—check		X	X		X	
Mower Spindles—grease			X		X	
Belts—check for wear/cracks					X	
Mower Housing—clean	X	X			X	
Belt Tension—check		initial		X	X	
Chipped Surfaces—paint					X	

CAUTION

POTENTIAL HAZARD

- If you leave the key in the ignition switch, someone could start the engine.

WHAT CAN HAPPEN

- Accidental starting of the engine could seriously injure you or other bystanders.

HOW TO AVOID THE HAZARD

- Remove the key from the ignition switch and pull the wire(s) off the spark plug(s) before you do any maintenance. Also push the wire(s) aside so it does not accidentally contact the spark plug(s).

Cutting Blade

To ensure a superior quality of cut, keep the blade(s) sharp. For convenient sharpening and replacement, you may want to have an extra blade(s).

WARNING

POTENTIAL HAZARD

- A blade that is worn or damaged could break apart and pieces could be thrown at bystanders or at you as you use the mower.

WHAT CAN HAPPEN

- Pieces of blade that may be thrown could seriously injure or kill you or bystanders.

HOW TO AVOID THE HAZARD

- Periodically inspect the blade for wear and damage. Immediately install a new blade if it is worn or damaged.

Inspecting the Blade(s)

1. Remove the mower; refer to Removing the Mower, page 11.
2. Inspect the cutting edges (Fig. 31). If the edges are not sharp or have nicks, remove the blade(s) and sharpen them; refer to Sharpening the Blade(s), page 21.
3. Inspect the blade(s), especially the curved area (Fig. 31). If you notice any damage, wear, or a slot forming in this area (Fig. 31), immediately install a new blade.

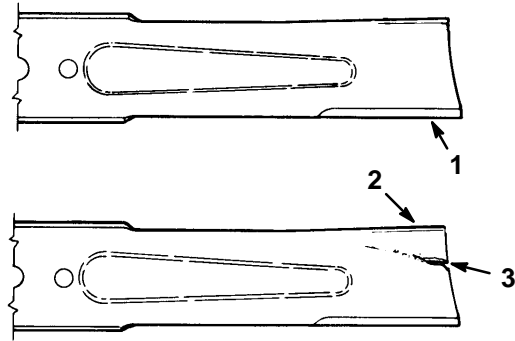

Figure 31

1. Cutting edge
2. Curved area
3. Wear/slot forming

151

Removing the Blade

1. Remove the mower; refer to Removing the Mower, page 11.
2. Carefully tip the mower over.
3. Hold the blade end using a rag or thickly padded glove. Remove the bolt, Bellville washer, and blade (Fig. 32). A block of wood may be wedged between the blade and the mower to lock the blade when you are removing the bolt.
4. Inspect all parts. If damage is noticed, install new parts.

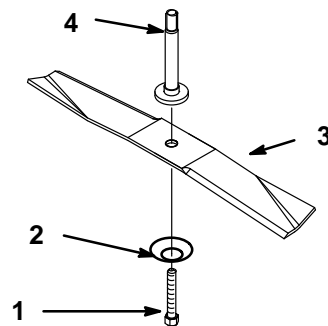

Figure 32

1. Bolt
2. Bellville Washer—concave side toward the blade
3. Blade
4. Spindle

1796

Sharpening the Blade(s)

1. Use a file to sharpen the cutting edge at both ends of the blade (Fig. 33). Maintain the original angle. The blade retains its balance if the same amount of material is removed from both cutting edges.

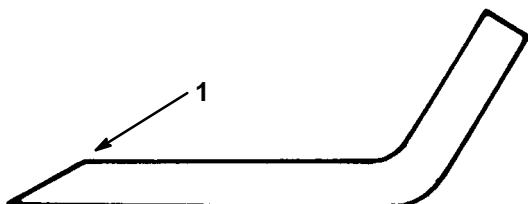

Figure 33

1. Sharpen at original angle

2. Check the balance of the blade by putting it on a blade balancer (Fig. 34). If the blade stays in a horizontal position, the blade is balanced and can be used. If the blade is not balanced, file some metal off the back side of the blade. Repeat this procedure until the blade is balanced.

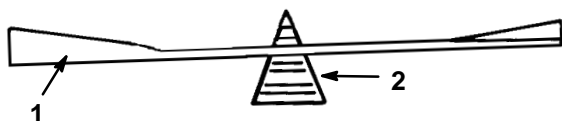

Figure 34

1. Blade
2. Balancer

Installing the Blade(s)

1. Hold the blade end using a rag or thickly padded glove. Install the blade, Bellville washer, and the blade bolt (Fig. 32).

IMPORTANT: The sail (curved part of the blade) must be pointing up toward the inside of the mower to ensure proper cutting.

2. Tighten the blade bolt to 40-60 ft-lb (54-81 N•m).

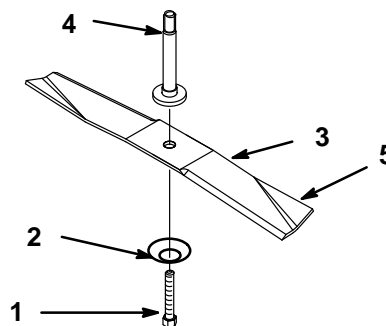

Figure 35

- | | |
|---|------------|
| 1. Bolt | 3. Blade |
| 2. Bellville Washer—concave side toward the blade | 4. Spindle |
| | 5. Sail |

1796

Greasing and Lubrication

Service Interval/Specification

Grease the mower after every 25 operating hours or once a year, whichever occurs first. Grease more frequently when operating conditions are extremely dusty or sandy.

Grease Type: General-purpose grease.

How to Grease

1. Disengage the power take off (PTO), set the parking brake, lower the attachment lift, and turn the ignition key to “STOP” to stop the engine. Remove the ignition key.
2. Clean the grease fittings with a rag. Make sure to scrape any paint off the end of the fitting(s).
3. Connect a grease gun to the fitting. Pump grease into the fittings.
4. Wipe up any excess grease.

Where to Add Grease

1. Lubricate the blade spindles (Fig. 36).

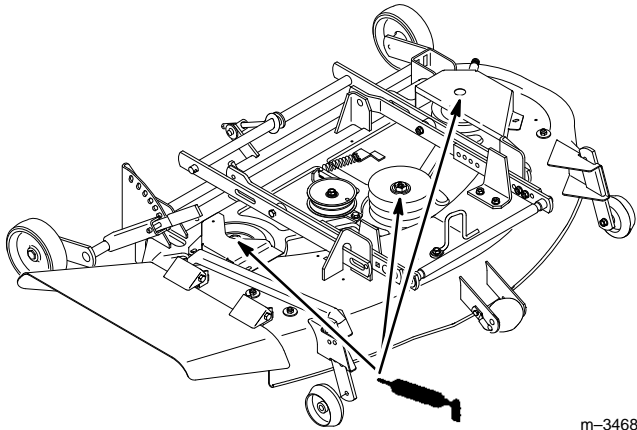

Figure 36

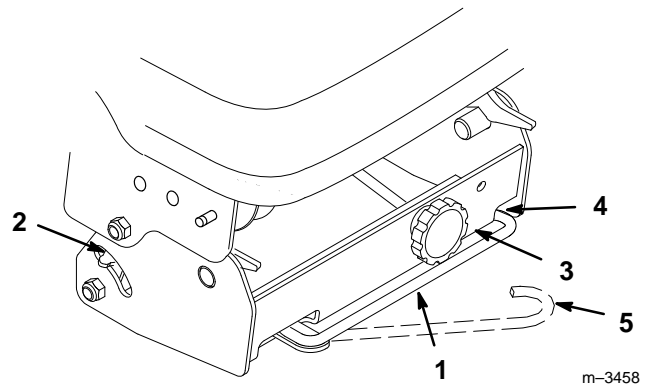

Figure 37

- | | |
|-------------------------------|-------------------------------------|
| 1. Belt tension release arm | 4. Seating position for tension arm |
| 2. Belt tension indicator (2) | 5. Belt tension released knob |
| 3. Belt tension adjustment | |

Checking PTO Drive Belt Tension

Check the PTO drive belt tension after 5 hours of operating with a new belt, then every 50 hours or once a year, whichever occurs first.

1. Check the tension indicators on each side of the pulley box. If the tension indicators are not in the same position on both the left and right sides, release the belt tension and turn the adjustment knob. Push the belt tension release arm back toward the pulley box to tension the belt (Fig. 37).
2. Repeat step 1 until the indicators move to the same position.
3. Once the indicators are in the same position on both sides, swing the tension release arm into the pulley box by moving it into the position shown in Fig. 35.

Extending PTO Drive Belt Life

The PTO drive belt will provide a long service life if properly installed and operated. Check the following items to help extend belt life.

- Maintain correct belt tension.
- Maintain correct mower level.
- Maintain correct blade slope in transport.
- Adjust the position of the cutter deck belt guide.
- Replace damaged pulleys.
- Always operate engine-powered attachments at full throttle.
- Avoid engaging the PTO when the cutter deck is in tall uncut grass or weeds.
- Cut tall grass and weeds with the mower in its highest position, making a second pass cutting at desired height.
- Regularly clean the cutter deck of any buildup of grass clippings.

- Use low range or reduce ground speed when mowing in heavy conditions or when mulching or bagging.

Blade Drive Belt

Removing the Blade Drive Belt

1. Remove the mower; refer to Removing the Mower, page 11.
2. Remove the pulley cover mounting screws and pulley covers from the blade pulleys (Fig. 38).
3. Release the spring (Fig. 38).
4. Remove the belt from the pulleys (Fig. 38).

Installing the Blade Drive Belt

1. Install the new belt around the blade pulleys and the idler pulleys.
2. Attach the spring (Fig. 38).
3. Install the left and right pulley covers with the mounting screws (Fig. 38).
4. Install the mower; refer to Installing the Mower, page 4.

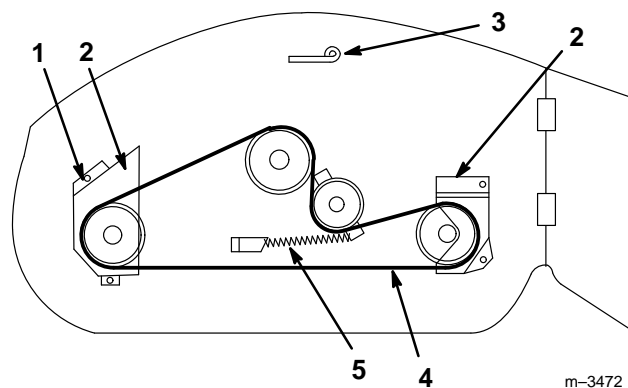

Figure 38

Top View

- | | |
|-----------------------|---------------|
| 1. Pulley cover screw | 4. Mower belt |
| 2. Pulley cover | 5. Spring |
| 3. Belt Guides | |

Washing the Underside of the Mower

After each use wash the underside of the mower, to prevent grass build-up and improve performance.

1. Park the tractor on a hard level surface.
2. Apply the parking brake, start the tractor, and raise the attachment lift.
3. Get off the tractor. Place the mower height-of-cut lever in the lowest cut position.
4. Lower the attachment lift, turn the ignition key to "STOP" to stop the engine. Remove the ignition key.
5. Attach a hose coupling to the end of the washout fitting and turn water on high (Fig. 39).

Note: Spread petroleum jelly on the washout fitting o-ring to help the coupling slide on easier and protect the o-ring.

6. Sit on the seat and start the engine. Engage the power take off (PTO) and let the mower run for one to three minutes.
7. Disengage the power take off (PTO) and turn the ignition key to "STOP" to stop the engine. Remove the ignition key. Wait for all moving parts to stop.
8. Turn the water off and remove the hose coupling from the washout fitting.

Note: If the mower is not clean after one washing, soak it and let it stand for 30 minutes. Then repeat the process.
9. Run the mower again for one to three minutes to remove excess water.

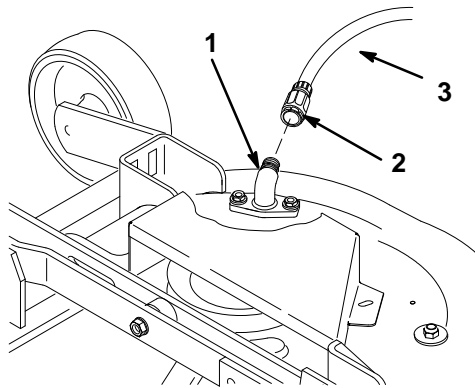

m-3592

Figure 39

1. Washout fitting
2. Coupling (not supplied)
3. Hose

! WARNING

POTENTIAL HAZARD

- **A broken or missing washout fitting could expose you and others to thrown objects or blade contact.**

WHAT CAN HAPPEN

- **Contact with thrown debris or blade contact will cause injury or death.**

HOW TO AVOID THE HAZARD

- **Replace broken or missing washout fitting immediately, before using the mower again.**
- **Plug any hole(s) in the mower with bolts and locknuts.**
- **Never put your hands or feet under the mower or through openings in the mower.**

Storage

1. Clean dirt and chaff from the top of the mower.
2. Scrape heavy buildup of grass and dirt from the underside of the mower. Then wash the mower with a garden hose. Run the tractor for two to three minutes.
3. Check the condition of the blade(s); refer to Cutting Blade, page 20.
4. Check the condition of the blade drive belt.
5. Check and tighten all bolts, nuts, and screws. Repair or replace any part that is damaged or defective.
6. Paint all scratched or bare metal surfaces. Paint is available from you Authorized Service Dealer.
7. Store the machine in a clean, dry garage or storage area. Remove both the ignition key and the "Key Choice" key and keep them in a memorable place. Cover the machine to protect it and keep it clean.

Troubleshooting

PROBLEM	POSSIBLE CAUSES	CORRECTIVE ACTION
Abnormal vibration.	<ol style="list-style-type: none"> 1. Cutting blade(s) is bent or unbalanced. 2. Blade mounting bolt is loose. 3. Engine mounting bolts are loose. 4. Loose engine pulley, idler pulley, or blade pulley. 5. Engine pulley is damaged. 	<ol style="list-style-type: none"> 1. Install new cutting blade(s). 2. Tighten blade mounting bolt. 3. Tighten engine mounting bolts. 4. Tighten the appropriate pulley. 5. Contact Authorized Service Dealer.
Blade(s) does not rotate.	<ol style="list-style-type: none"> 1. Blade drive belt is worn, loose or broken. 2. Blade drive belt is off pulley. 3. PTO belt is worn, loose or broken. 	<ol style="list-style-type: none"> 1. Install new blade drive belt. 2. Install blade drive belt and check idler pulley and belt guides for correct position. 3. Install new PTO belt.
Uneven cutting height.	<ol style="list-style-type: none"> 1. Tire pressure is incorrect. 2. Mower is not level. 3. Underside of mower is dirty. 	<ol style="list-style-type: none"> 1. Set tire pressure. 2. Level mower from side-to-side and front-to-rear. 3. Clean the underside of the mower.
Insufficient transport height.	<ol style="list-style-type: none"> 1. Lift arm cams are improperly adjusted. 	<ol style="list-style-type: none"> 1. Adjust lift arm cams.
PTO (cutter deck) belt comes off of pulleys, slips or fails.	<ol style="list-style-type: none"> 1. Belt tension is incorrect. 2. Mower level is incorrect. 3. Blade slope in transport is incorrect. 4. Cutter deck belt guide is loose or incorrectly adjusted. 5. Belt is worn or damaged. 6. Pulley is damaged. 7. Engine is not at full throttle. 	<ol style="list-style-type: none"> 1. Adjust belt tension. 2. Adjust mower level. 3. Adjust blade slope in transport. 4. Adjust and tighten belt guide. 5. Install new belt. 6. Contact Authorized Service Dealer. 7. Always operate engine-powered attachments at full throttle.

PROBLEM	POSSIBLE CAUSES	CORRECTIVE ACTION
<p>PTO (cutter deck) belt comes off of pulleys, slips or fails. (continued)</p>	<p>8. PTO is being engaged when cutter deck is in tall uncut grass or weeds.</p> <p>9. Cutter deck is overloaded because mulching or bagging requires more power.</p> <p>10. Cutter deck is overloaded because too much grass is being cut at a time.</p> <p>11. Cutter deck is overloaded because deck is clogged with grass clippings.</p> <p>12. Cutter deck is overloaded because tractor is mowing too fast for conditions.</p>	<p>8. Engage PTO only in shorter or previously cut grass.</p> <p>9. Reduce ground speed when mulching or bagging.</p> <p>10. Cut tall grass and weeds with mower in its highest position, making a second pass cutting at height desired.</p> <p>11. Clean cutter deck.</p> <p>12. Reduce ground speed.</p>