



**Count on it.**

**Parts Catalog**

**Topdresser 2500**

Model No. 44507—Serial No. 403420001 and Up



# Ordering Replacement Parts

To order replacement parts, please supply the part number, the quantity, and the description of each part desired.

## Understanding Reference Numbers

Each identified part in an illustration has a reference number. The reference number for a part also appears in the parts list, along with other information about the part.

This catalog uses two special reference number formats, one to indicate parts in a service assembly and another to indicate the quantity of a given part in an illustration.

## Service Assembly Reference Numbers

Parts in service assemblies have reference numbers in the form a:b. The a represents the reference number of the entire service assembly and the b represents a sequential number unique to each part within the service assembly.

For example, a wheel assembly might be identified by reference number 6, the tire by 6:1, the valve by 6:2, and the wheel by 6:3. When you order the assembly identified by reference number 6, you receive all parts identified by reference numbers 6:1, 6:2, and 6:3. However, you may also order any part individually. Reference numbers of this type appear in illustration and in parts lists.

## Reference Numbers Indicating Quantity

In an illustration, if a reference number indicates more than one part, the reference number has the form nX y. The n represents the quantity of the part, the X is the multiplication symbol, and the y represents the reference number.

For example, in an illustration, the reference number 2X 37 means that two of the parts identified by reference number 37 are indicated.

# Contents

Cradle Assembly .....	4
Cradle and Trailer Assembly .....	5
Hydraulic Motor Assembly No. 100-1459 .....	7
Hydraulic Manifold Assembly .....	8
Hydraulic Installation Assembly .....	9
Slider Bed and Roller Assembly .....	10
Gate Assembly .....	11
Brush and Motor Assembly .....	12
Hopper Assembly .....	14
Gate Slide and Brush Guard Assembly .....	15
Attachments and Accessories .....	16

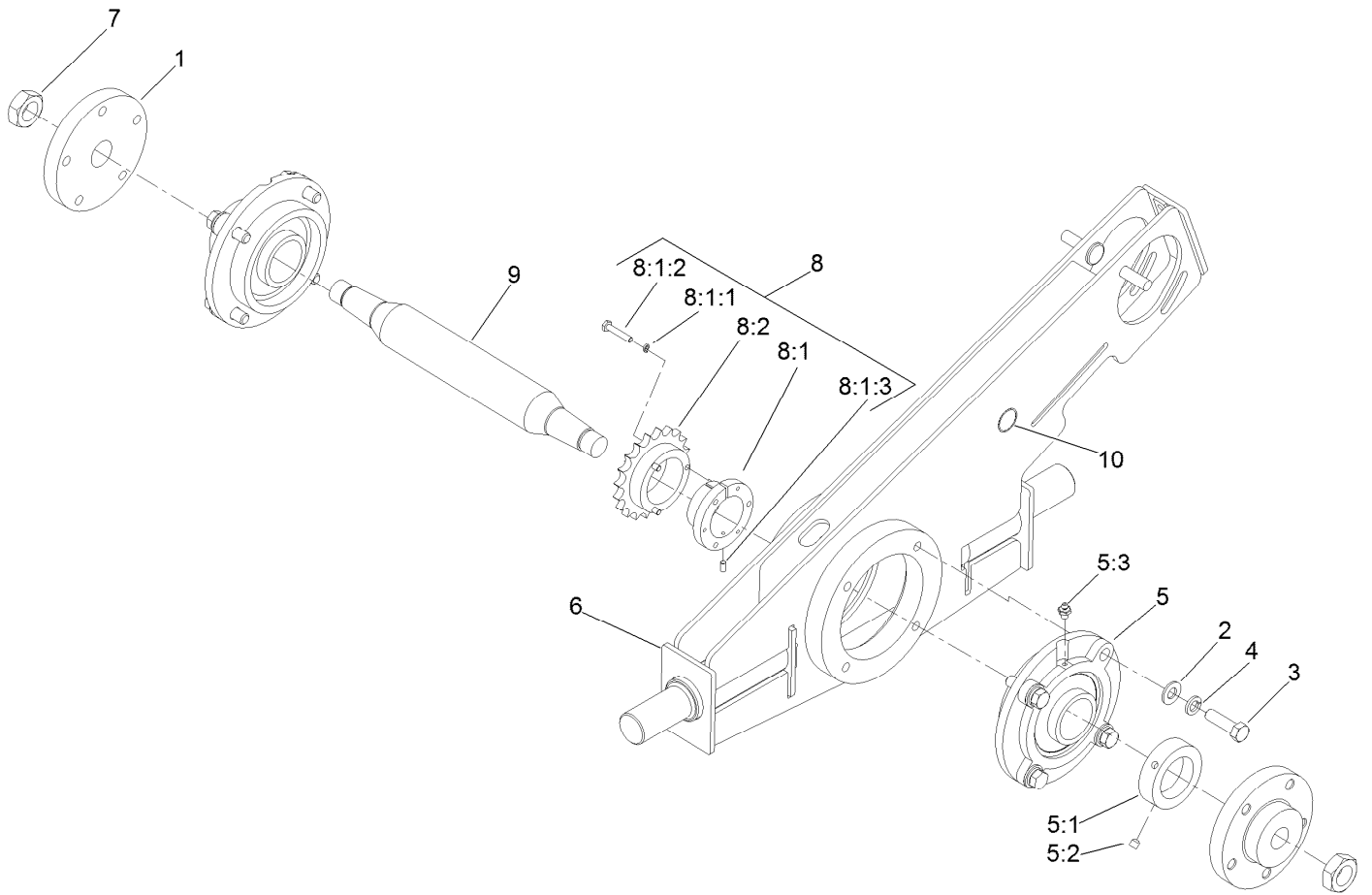

## Cradle Assembly

<i>Ref.</i>	<i>Part Number</i>	<i>Qty.</i>	<i>Description</i>	<i>Ref.</i>	<i>Part Number</i>	<i>Qty.</i>	<i>Description</i>
1	100-1418-03	4	Hub	7	26-3790	4	Nut-Lock
2	3256-26	16	Washer-Flat	8	100-7690	2	Sprocket And Hub ASM
3	325-7	16	Screw-HH	8:1	100-7730	1	Bushing
4	3253-7	16	Washer-Lock	8:1:1	3253-18	3	Washer-Lock
5	100-1455	4	Bearing	8:1:2	32104-96	3	Screw-HH
5:1	302-2	1	Fitting-Grease	8:1:3	3245-9	1	Screw-Set, HSH
5:2	99-0195	1	Screw-Set, HSH	8:2	100-7731	1	Sprocket-Driven, 20 Tooth
5:3	99-0194	1	Collar-Locking	9	100-1490	2	Axle-Cradle
6	100-1488-03	2	Cradle	10	58-6520	4	Decal-Grease

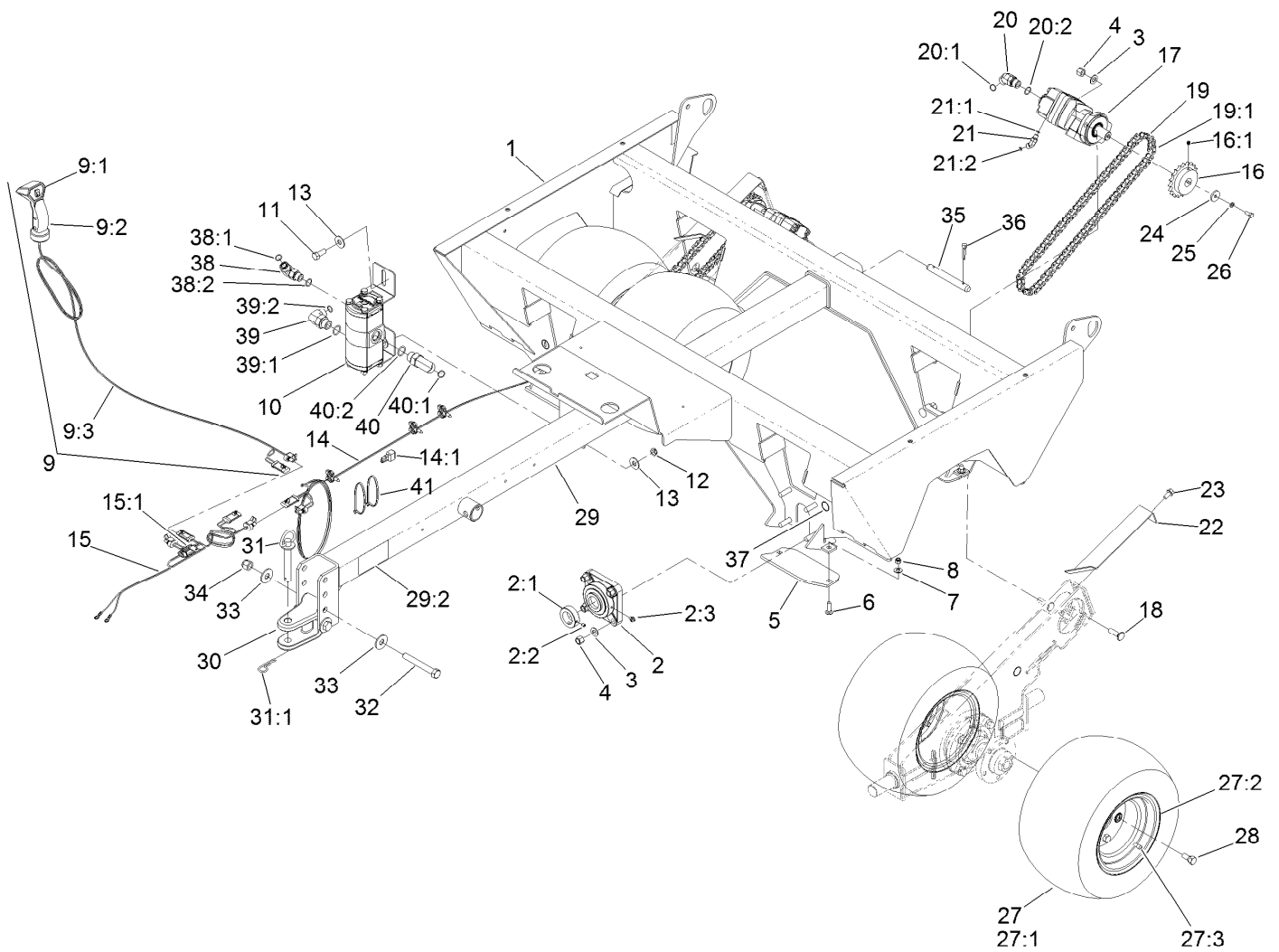

## Cradle and Trailer Assembly

<i>Ref.</i>	<i>Part Number</i>	<i>Qty.</i>	<i>Description</i>	<i>Ref.</i>	<i>Part Number</i>	<i>Qty.</i>	<i>Description</i>
1	106-9671-01	1	Frame-Trailer	15	99-0198	1	Harness-Wire, Battery
2	100-1456	4	Bearing	15:1	110928	1	Fuse-Blade, 5 Amp
2:1	3246-17	1	Setscrew-HSH	16	100-7691	2	Sprocket-Chain, Roller
2:2	302-2	1	Fitting-Grease	16:1	3246-3	2	Screw-HSH
2:3	01-172-0090	1	Collar-Lock	17	100-1459	2	Motor-HYD
3	3256-26	20	Washer-Flat	18	100-7698	2	Bolt-Carriage
4	3296-23	20	Nut-Lock, NI	19	100-1472	2	Chain-Cradle, Roller
5	100-7678-01	4	Plate-Skid	19:1	2710-16	1	Link-Chain
6	3231-25	8	Bolt-CARR	20	340-14	4	Fitting-HYD, 45 DEG
7	3256-25	8	Washer-Flat	20:1	237-65	1	O-Ring
8	3296-39	8	Nut-Lock, NI	20:2	237-80	1	O-Ring
9	106-9694	1	Handle-Control	21	340-103	2	Fitting-HYD, 45 DEG
9:1	106-9696	1	Switch-Rocker	21:1	237-78	1	O-Ring
9:2	106-9697	1	Handle	21:2	237-21	1	O-Ring
9:3	106-9695	1	Harness-Wire, Switch	22	100-1452-03	2	Cover-Cradle, Top
10	121-6441	1	Pump-Charge	23	3234-1	2	Screw-HHF
11	325-5	2	Screw-HH	24	71-5320	2	Washer-Support, Engine
12	3296-45	2	Nut-Hex	25	3253-4	2	Washer-Lock
13	3256-6	4	Washer-Flat	26	322-3	2	Screw-HH
14	99-0008	1	Harness-Wire, Trailer	27	106-9690	4	Tire And Wheel ASM
14:1	100-4918	1	Diode	27:1	106-9691	1	Tire-4-Ply

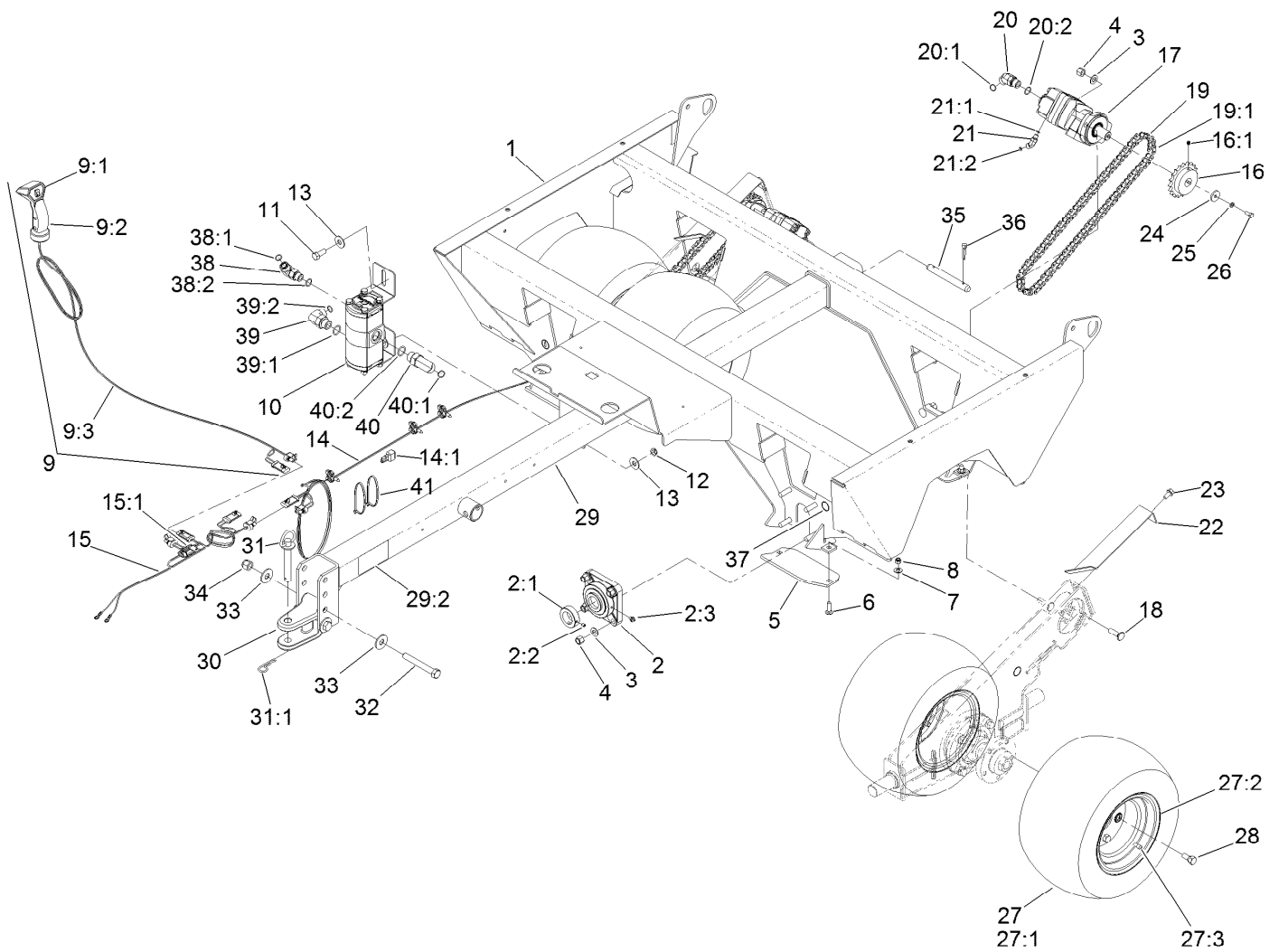

## Cradle and Trailer Assembly (continued)

<i>Ref.</i>	<i>Part Number</i>	<i>Qty.</i>	<i>Description</i>	<i>Ref.</i>	<i>Part Number</i>	<i>Qty.</i>	<i>Description</i>
27:2	99-0174	1	Rim	37	58-6520	4	Decal-Grease
27:3	232-27	1	Stem-Valve	38	340-17	1	Fitting-Elbow, 90 DEG
28	71-4450	20	Bolt-Lug	38:1	237-65	1	O-Ring
29	100-7686	1	Tongue ASM	38:2	237-80	1	O-Ring
29:2	100-7679	1	Decal-Warning	39	340-139	1	Fitting-Elbow 90
30	131-4381-01	1	Hitch-Clevis	39:1	237-81	1	O-Ring
31	13-6200	1	Pin-Hitch, Pointed	39:2	237-65	1	O-Ring
31:1	3290-343	1	Pin-Hair	40	340-142	1	Fitting-Elbow, 90 DEG
32	327-12	2	Screw-HH	40:1	237-58	1	O-Ring
33	3256-7	4	Washer-Flat	40:2	237-81	1	O-Ring
34	3296-53	2	Nut-Lock, NI	41	3290-379	2	Tie-Cable
35	100-7694	2	Pin-Clevis				
36	92-1298	4	Pin-Lynch				

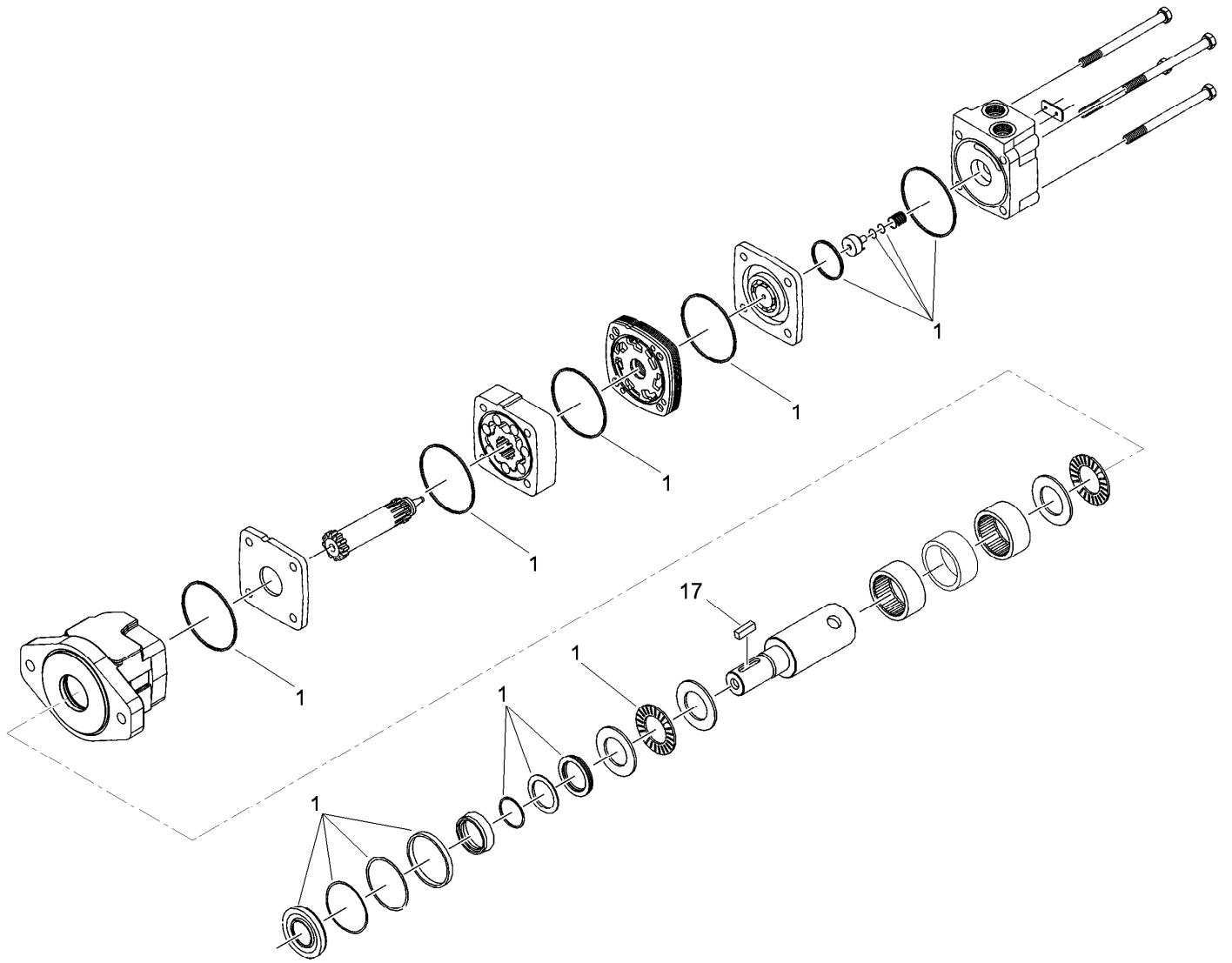

## Hydraulic Motor Assembly No. 100-1459

<i>Ref.</i>	<i>Part Number</i>	<i>Qty.</i>	<i>Description</i>
1	100-1466	1	Seal Kit
17	5-7280	1	Key

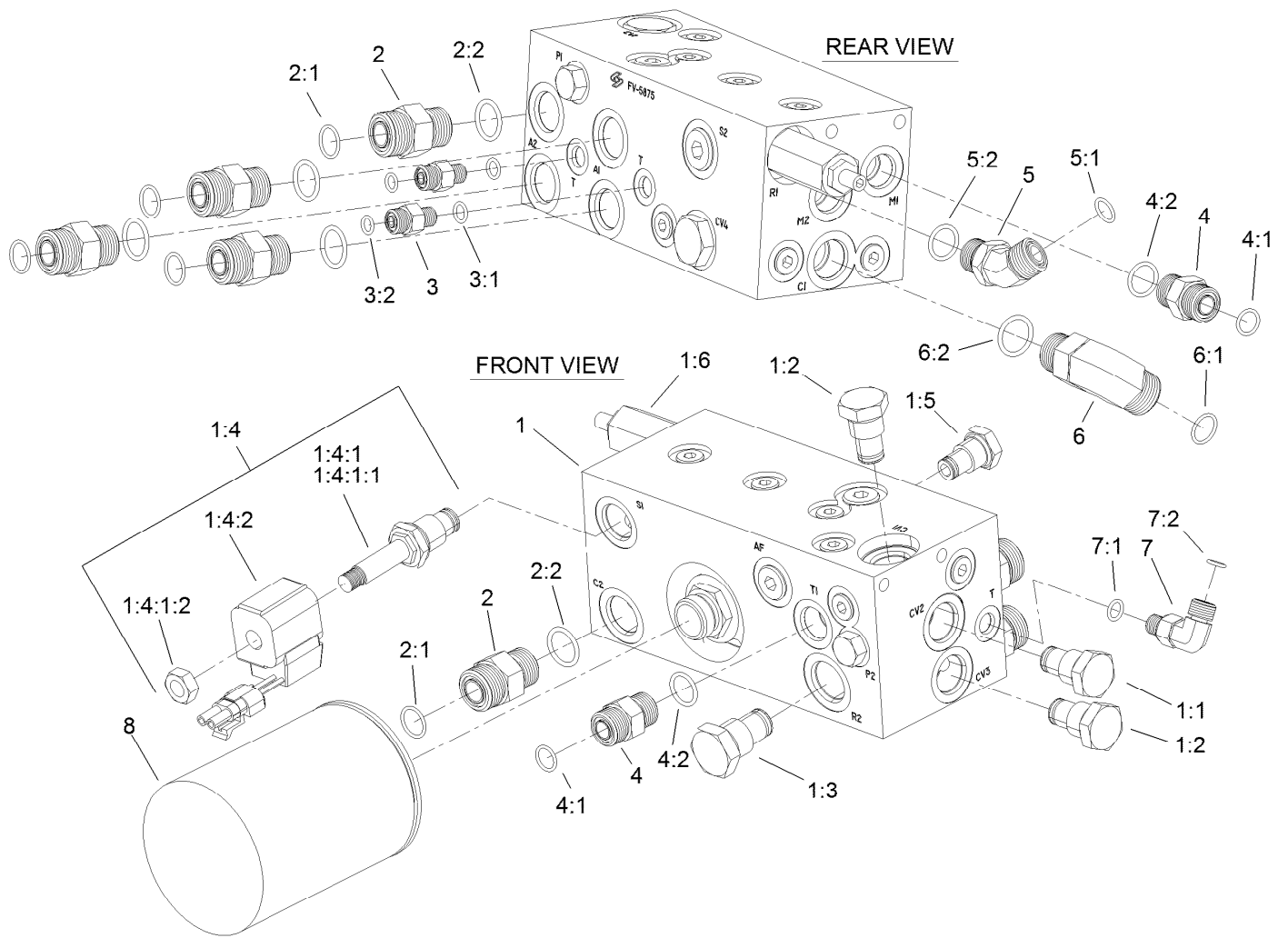

## Hydraulic Manifold Assembly

Ref.	Part Number	Qty.	Description
1	106-9667	1	HYD Manifold ASM
1:1	100-7723	1	Valve-Check
1:2	106-9669	2	Valve-Check
1:3	106-9670	1	Valve-Check
1:4	100-7699	1	Solenoid Valve ASM
1:4:1	100-7718	1	Valve-Solenoid
1:4:1:1	95-1237	1	Seal Kit
1:4:1:2	121-6403	1	Nut-Solenoid Valve
1:4:2	100-7720	1	Coil-Solenoid
1:5	106-9668	1	Valve-Check
1:6	100-7740	1	Valve-Relief
2	340-7	5	Fitting-Straight
2:1	237-65	1	O-Ring
2:2	237-80	1	O-Ring
3	340-92	2	Fitting-Straight
3:1	237-78	1	O-Ring

Ref.	Part Number	Qty.	Description
3:2	237-21	1	O-Ring
4	340-4	2	Fitting-Straight
4:1	237-30	1	O-Ring
4:2	237-79	1	O-Ring
5	340-101	1	Fitting-HYD, 45 DEG
5:1	237-30	1	O-Ring
5:2	237-79	1	O-Ring
6	340-17	1	Fitting-Elbow, 90 DEG
6:1	237-65	1	O-Ring
6:2	237-80	1	O-Ring
7	340-132	1	Fitting-Elbow, 90 DEG
7:1	237-78	1	O-Ring
7:2	237-21	1	O-Ring
8	86-3010	1	Filter-Oil



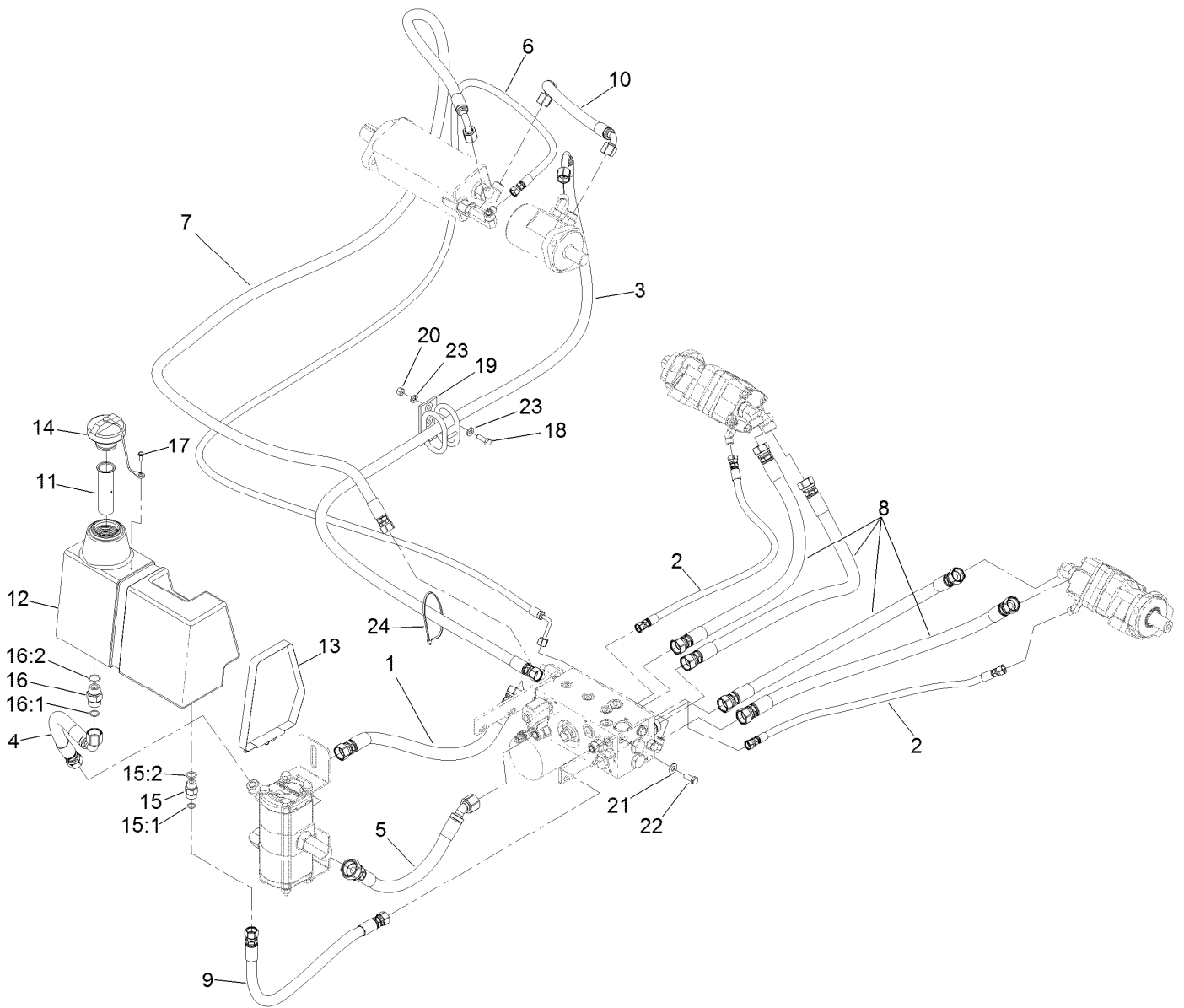

## Hydraulic Installation Assembly

<i>Ref.</i>	<i>Part Number</i>	<i>Qty.</i>	<i>Description</i>	<i>Ref.</i>	<i>Part Number</i>	<i>Qty.</i>	<i>Description</i>
1	105-0639	1	HYD Hose ASM	15	340-4	1	Fitting-Straight
2	106-9674	2	Hose-HYD	15:1	237-30	1	O-Ring
3	104-0304	1	HYD Hose ASM	15:2	237-79	1	O-Ring
4	100-7657	1	HYD Hose ASM	16	340-7	1	Fitting-Straight
5	106-9675	1	HYD Hose ASM	16:1	237-65	1	O-Ring
6	106-9677	1	HYD Hose ASM	16:2	237-80	1	O-Ring
7	104-0303	1	HYD Hose ASM	17	32105-23	1	Screw
8	106-9678	4	HYD Hose ASM	18	322-5	2	Screw-HH
9	106-9676	1	HYD Hose ASM	19	99-5621	1	Guide-Hose
10	99-0177	1	Hose-HYD	20	3296-29	2	Nut-Lock, NI
11	92-1705	1	Filter-Screen	21	3256-24	4	Washer-Flat
12	133-5499	1	Tank-Hydraulic	22	323-5	4	Screw-HH
13	100-7693	1	Clamp, T-Bolt	23	3256-23	4	Washer-Plain
14	93-7160	1	Cap-Oil, HYD	24	3290-379	6	Tie-Cable

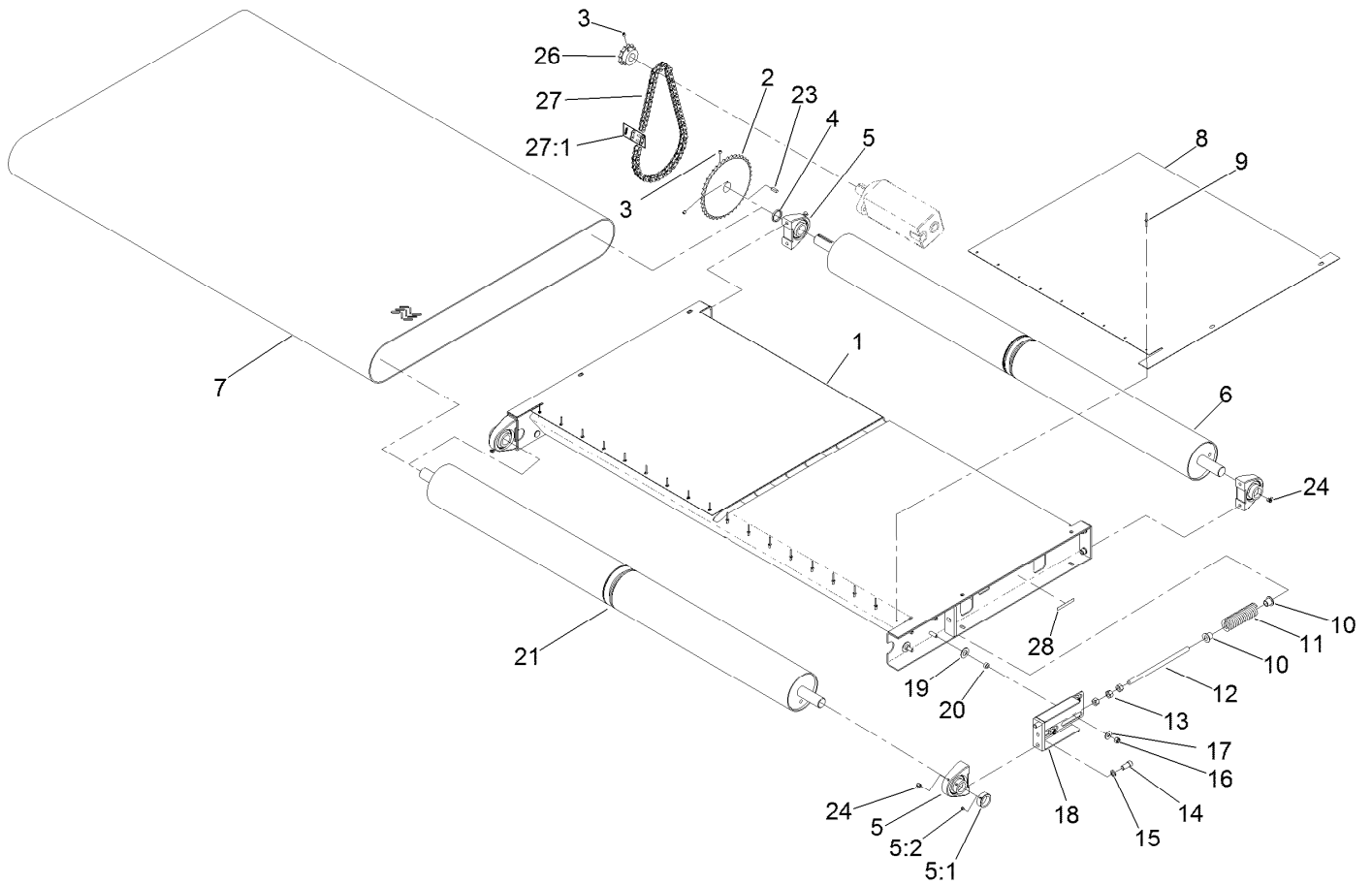

## Slider Bed and Roller Assembly

<i>Ref.</i>	<i>Part Number</i>	<i>Qty.</i>	<i>Description</i>	<i>Ref.</i>	<i>Part Number</i>	<i>Qty.</i>	<i>Description</i>
1	99-0038-01	1	Frame-Bed, Slider	14	100-1438	8	Screw-Socket Head, Torx
2	99-0166-03	1	Sprocket-Driven	15	3253-6	8	Washer-Lock
3	3246-3	4	Screw-HSH	16	3296-39	8	Nut-Lock, NI
4	99-0017	1	Spacer-Sprocket	17	3256-4	8	Washer-Flat
5	99-0158	4	Bearing-Base, Tapped	18	99-0050-01	2	Plate-Spring
5:1	251-246	1	Collar W/Set Screws	19	99-0052	8	Washer-Slide
5:2	106-9662	1	Screw-Set, HSH	20	100-1401	8	Spacer-Slide, Spring
6	99-0046	1	Roller-Rear	21	99-0044	1	Roller-Front
7	100-1425	1	Belt Kit	23	10-7070	1	Key-Square
8	99-0047	2	Plate-Wear	24	302-60	4	Fitting-Grease
9	3269-28	18	Rivet-Pop	26	99-0165-03	1	Sprocket-Drive
10	100-1414	4	Holder-Spring	27	99-0164	1	Chain-Roller
11	99-0163	2	Spring-Compression	27:1	2710-16	1	Link-Chain
12	99-0118	2	Pin-Spring	28	133-8061	2	Decal-Warning
13	3217-9	6	Nut-HH				

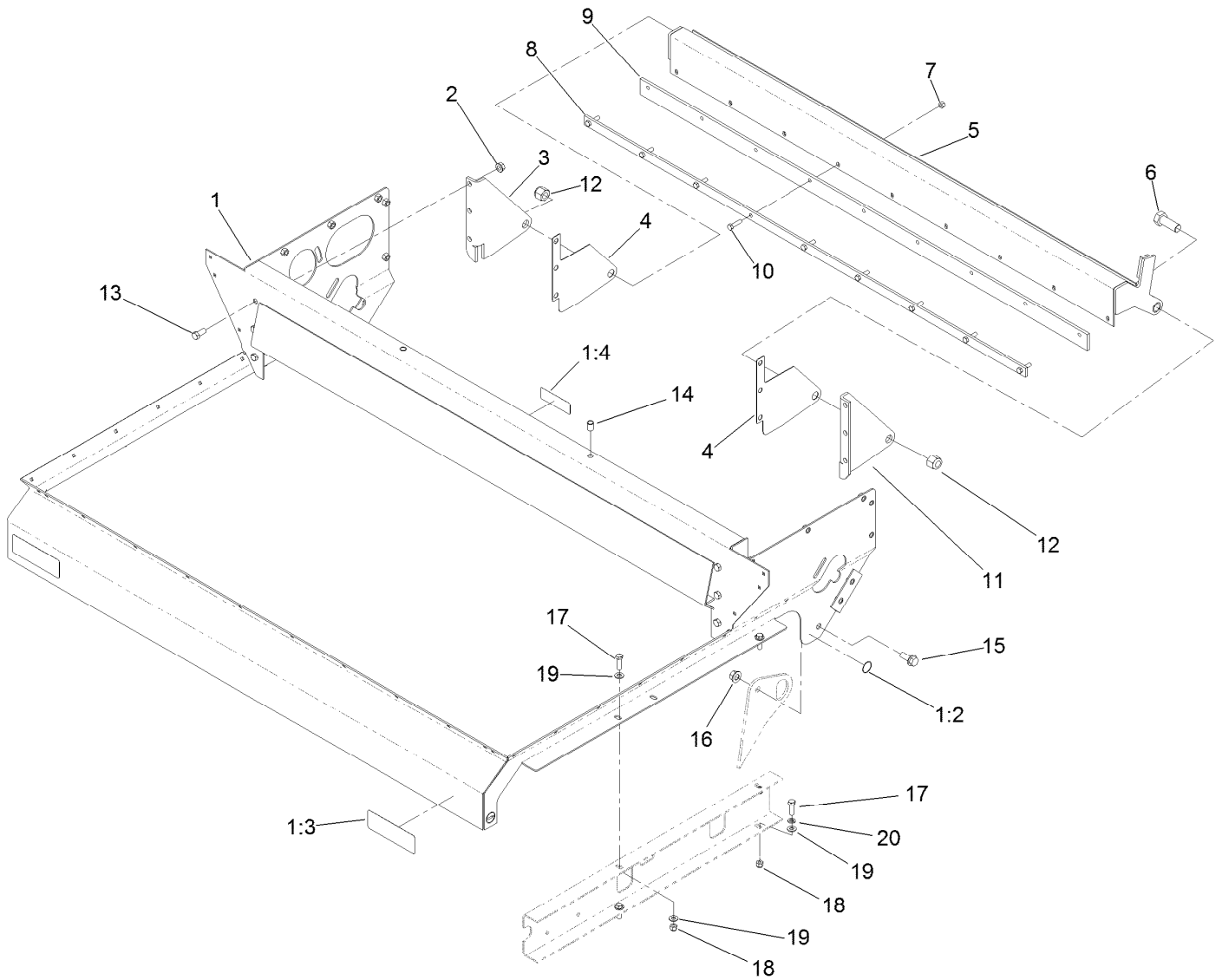

## Gate Assembly

Ref.	Part Number	Qty.	Description
1	100-1435	1	Hopper Frame ASM
1:2	58-6520	4	Decal-Grease
1:3	138-5941	2	Decal-Danger, Crushing
1:4	117-4979	1	Decal-Warning
2	32128-37	6	Nut-HF
3	99-0079-01	1	Bracket-Gate Pivot, RH
4	99-0117	2	Wareplate-Gate
5	99-0068-01	1	Gate
6	328-24	2	Screw-HH
7	3296-29	9	Nut-Lock, NI
8	99-0089-01	1	Plate-Backing
9	99-0074	1	Seal-Gate

Ref.	Part Number	Qty.	Description
10	322-6	9	Screw-HH
11	99-0078-01	1	Bracket-Gate Pivot, LH
12	3296-51	2	Nut-Lock, NI
13	324-4	6	Screw-HH
14	32148-9	2	Nut-Clinch
15	3234-38	2	Screw-HHF
16	99-5107	2	Nut-Lock
17	323-7	8	Screw-HH
18	3296-39	4	Nut-Lock, NI
19	3256-24	12	Washer-Flat
20	3253-21	4	Washer-Lock

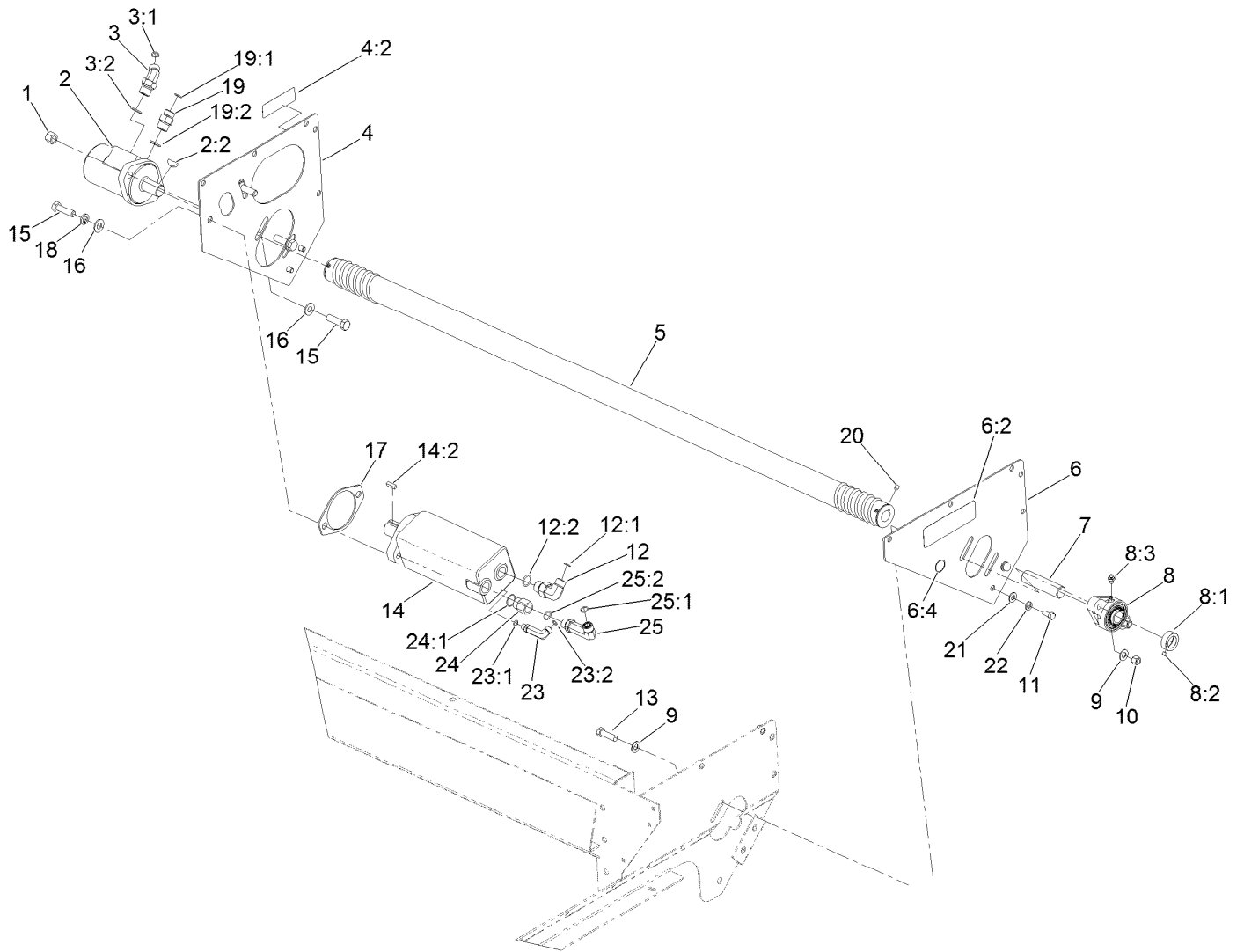

## Brush and Motor Assembly

Ref.	Part Number	Qty.	Description	Ref.	Part Number	Qty.	Description
1	3296-23	2	Nut-Lock, NI	9	3256-25	4	Washer-Flat
2	99-0156	1	HYD Motor ASM	10	3296-48	2	Nut-Hex
2:1	100-1446	1	Seal Kit ●	11	323-4	4	Screw-HH
2:2	3257-8	1	Key-Woodruff	12	340-105	1	Fitting-Elbow, 90 DEG
3	340-89	1	Fitting-HYD, 45 DEG	12:1	237-80	1	O-Ring
3:1	237-30	1	O-Ring	12:2	237-30	1	O-Ring
3:2	237-80	1	O-Ring	13	324-6	2	Screw-HH
4	100-1431	1	RH Motor Brace ASM	14	99-0155	1	HYD Motor Conveyor ASM
4:2	117-4979	1	Decal-Warning	14:1	56-6890	1	Seal Kit ●
5	99-0162	1	Brush	14:2	10-7070	1	Key-Square
6	100-1430	1	LH Motor Brace ASM	15	325-7	4	Screw-HH
6:2	138-5940	1	Decal-Danger	16	3256-26	4	Washer-Flat
6:4	58-6520	1	Decal-Grease	17	99-0116	1	Plate-Spacer
7	99-0041	1	Shaft-Brush	18	3253-7	2	Washer-Lock
8	99-0160	1	Bearing	19	340-6	1	Fitting-Straight
8:1	251-249	1	Collar W/Set Screws	19:1	237-30	1	O-Ring
8:2	3245-35	1	Screw-Set, HSH	19:2	237-80	1	O-Ring
8:3	302-2	1	Fitting-Grease	20	3246-3	4	Screw-HSH

● Not illustrated

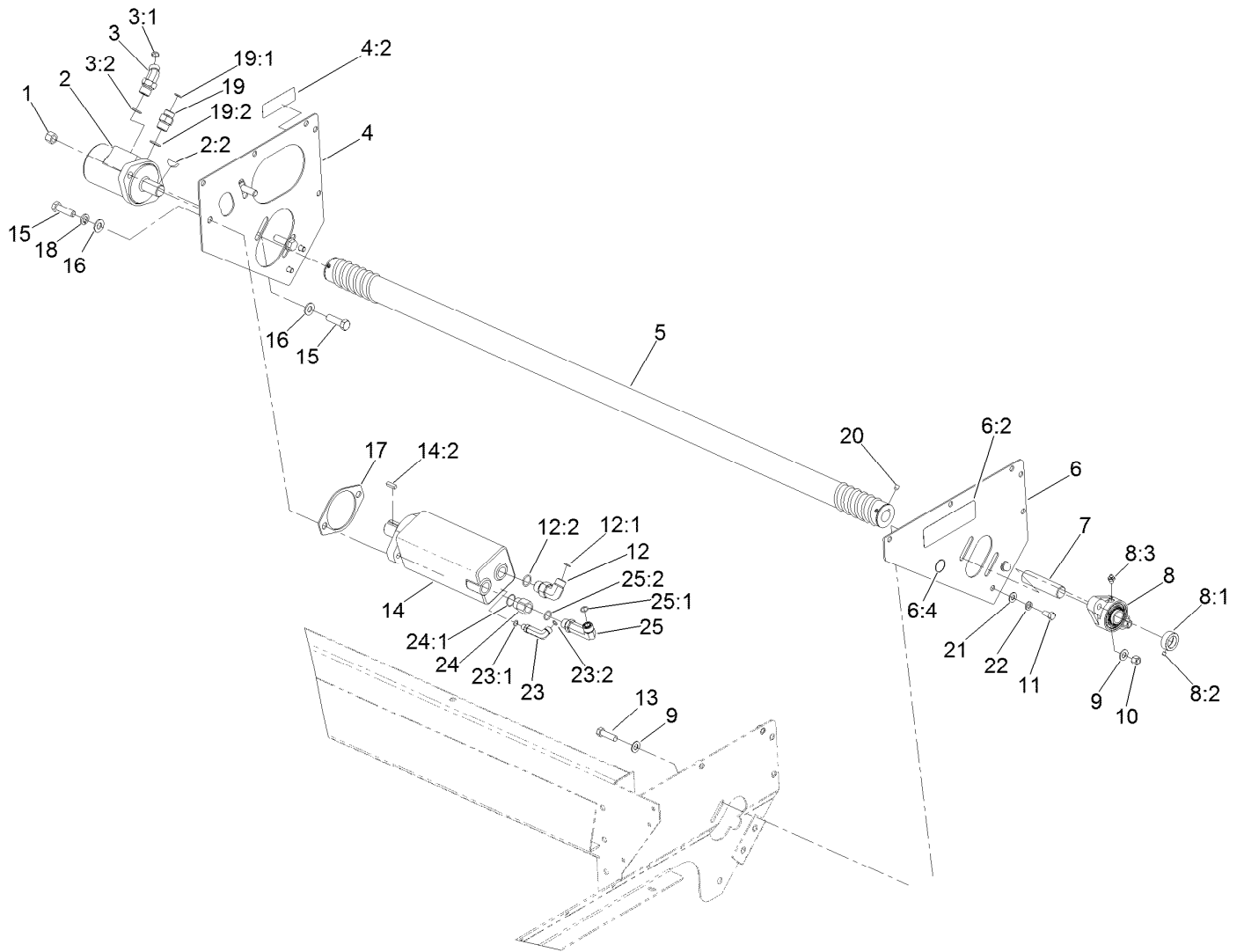

## Brush and Motor Assembly (continued)

<i>Ref.</i>	<i>Part Number</i>	<i>Qty.</i>	<i>Description</i>	<i>Ref.</i>	<i>Part Number</i>	<i>Qty.</i>	<i>Description</i>
21	3256-24	4	Washer-Flat	24	100-4617	1	Adapter-HYD
22	3253-21	4	Washer-Lock	24:1	237-80	1	O-Ring
23	100-7695	1	Fitting-Elbow 90	25	99-6160	1	Fitting-Elbow, 90 Long
23:1	237-78	1	O-Ring	25:1	237-30	1	O-Ring
23:2	237-21	1	O-Ring	25:2	237-79	1	O-Ring

● Not illustrated

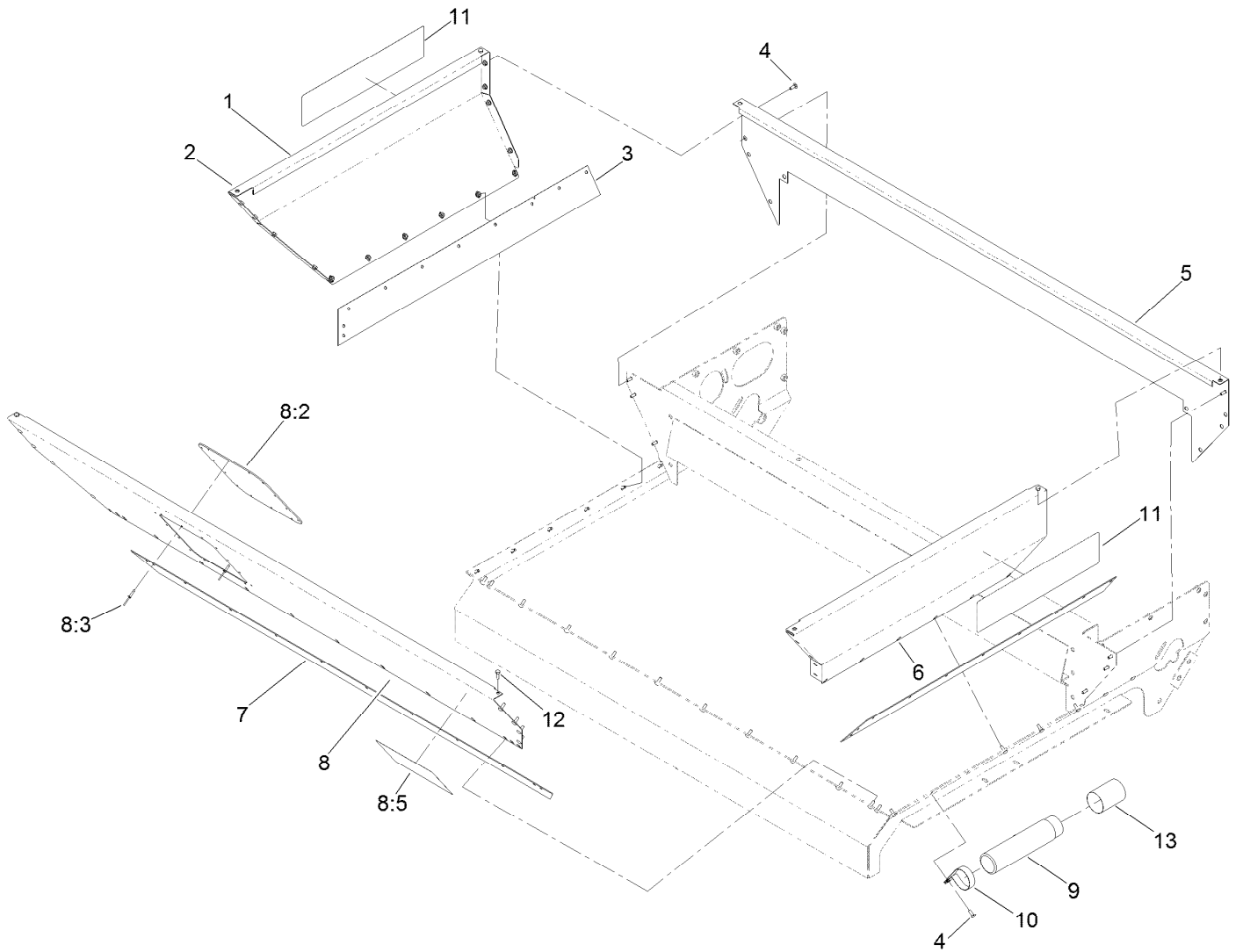

## Hopper Assembly

Ref.	Part Number	Qty.	Description	Ref.	Part Number	Qty.	Description
1	99-0123	1	Panel-Hopper, RH	8:3	3269-28	14	Rivet-Pop
2	32128-33	48	Nut-HF	8:5	99-0016	1	Decal-Danger
3	99-0142	2	Seal-Sand, Side	9	104-7050	1	Tube-Manual
4	3229-25	44	Screw-CARR	10	2412-133	2	Clamp-R
5	99-0121	1	Panel-Hopper, Back	11	138-5950	2	Decal-Top Dresser 2500
6	99-0124	1	Panel-Hopper, LH	12	321-4	4	Screw-HH
7	99-0143	1	Seal-Sand, Front	13	104-7048	1	Cap-Housing
8	100-1465	1	Front Hopper Panel ASM	99	505-73	1	Sealant-Silicone ●
8:2	99-0120	1	Hopper-Window				

● Not illustrated

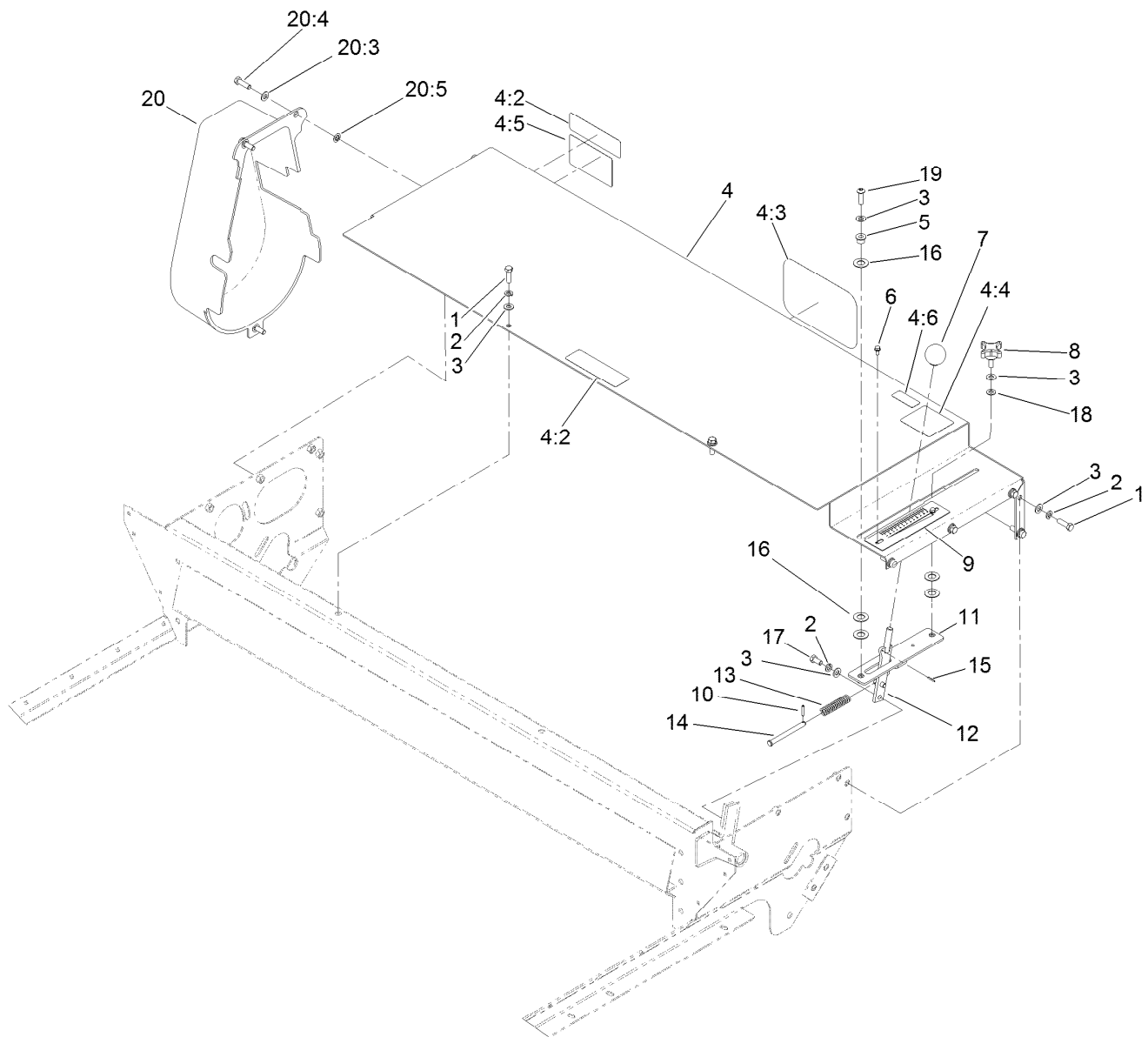

## Gate Slide and Brush Guard Assembly

Ref.	Part Number	Qty.	Description
1	323-7	10	Screw-HH
2	3253-21	12	Washer-Lock
3	3256-24	14	Washer-Flat
4	100-1432	1	Brush Guard ASM
4:2	138-5940	2	Decal-Danger
4:3	92-1242	1	Decal
4:4	138-5949	1	Decal-Danger
4:5	105-0708	1	Decal-Danger
4:6	132-1316	1	Decal-Danger, Belt
5	256-259	1	Bushing-Flange
6	93-6083	2	Screw-HWH
7	233-48	1	Knob
8	100-1449	1	Knob
9	100-1416	1	Scale-Gate

Ref.	Part Number	Qty.	Description
10	32121-45	1	Pin-Spring
11	99-0073-03	1	Plate-Block, Slide
12	100-1406-03	1	Handle-Gate
13	100-1448	1	Spring-Gate
14	100-1413	1	Pin-Clevis
15	32121-40	1	Pin-Spring
16	99-0052	5	Washer-Slide
17	323-4	2	Screw-HH
18	95-4896	1	Washer-Nylon
19	3274-63	1	Screw-HSBH
20	119-2860	1	Chain Guard ASM
20:3	3256-24	3	Washer-Flat
20:4	323-7	3	Screw-HH
20:5	107-3154	3	Nut-Push

# Attachments and Accessories

## For 44507 Topdresser 2500

<b>Product Name</b>	<b>Model/Part</b>
Sprocket-H5015 .....	01-262-0040
Hand Throttle Kit.....	07420
Premium Bio-Degradable Hydraulic Fluid (5 Gallon Pail).....	100-7674
Brake Kit .....	106-9680
Jack ASM .....	106-9699
Safety Chain Kit.....	139-3179
Filter-oil.....	86-3010
Harness-Wire, Battery .....	99-0198



**Notes:**

**Notes:**

**Notes:**



**Count on it.**