

LAWN-BOY®

320R, 320E

Snowthrower

Model No. 28220-00000001 and Up

Model No. 28220-20000001 and Up

Model No. 28222-00000001 and Up

Model No. 28222-20000001 and Up

Parts Catalog

Ordering Replacement Parts

To order replacement parts, please supply: the part number, the quantity, and the description of each part desired.

Understanding Reference Numbers

Each identified part in an illustration has a reference number. The reference number for a part also appears in the parts list, along with other information about the part.

This catalog uses two special reference number formats, one to indicate parts in a service assembly and another to indicate the quantity of a given part in an illustration.

Service Assembly Reference Numbers

Parts in service assemblies have reference numbers in the form **a:b**. The **a** represents the reference number of the entire service assembly and the **b** represents a sequential number unique to each part within the service assembly.

For example, a wheel assembly might be identified by reference number **6**, the tire by **6:1**, the valve by **6:2**, and the wheel by **6:3**. When you order the assembly identified by reference number **6**, you receive all parts identified by reference numbers **6:1**, **6:2**, and **6:3**. However, you may also order any part individually.

Reference numbers of this type appear in illustrations and in part lists.

Reference Numbers Indicating Quantity

In an illustration, if a reference number indicates more than one part, the reference number has the form **nX y**. The **n** represents the quantity of the part, the **X** is the multiplication symbol, and the **y** represents the reference number.

For example, in an illustration, the reference number **2X 37** means that two of the parts identified by reference number **37** are indicated.

Contents

Description	Page	Description	Page
Deflector & Control Panel Assembly	3	Rotor Assembly	10
Deflector & Control Panel Assembly (cont.)	4	Carburetor No. 640086	11
Housing & Side Plate Assembly	5	Engine Tecumseh	
Engine & Gas Tank Assembly	6	Model No. HSK-600-1681T	12
Engine & Gas Tank Assembly (cont.)	7	Engine Tecumseh	
Motor & Switch Housing Assembly (120 Volt)		Model No. HSK-600-1681T (cont.)	13
(Model No. 28222 Only)	8	Recoil Starter No. 590743	14
Handle Assembly	9	Maintenance	15

Accessories

Description	Model / Part No.	Description	Model / Part No.
-------------	------------------	-------------	------------------

Part Description Abbreviations

Part descriptions in this catalog may include the following abbreviations.

Abbreviation	Meaning	Abbreviation	Meaning
AR	as required	INC	incorporated
ASM	assembly	LH	left hand
CARR	carriage	NI	nylon insert
DEG	degrees	PPH	Phillips pan head
FH	flat head	PTH	Phillips truss head
GA	gauge	PTO	power take off
HF	hex flange	RH	right hand
HH	hex head	SFH	slotted fillister head
HHF	hex head flange	SHH	slotted hex head
HLH	hex lag head	SQH	square head
HJ	hex jam	SHWH	slotted hex washer head
HOC	height-of-cut	SPH	slotted pan head
HS	hex socket	SRH	slotted round head
HSBH	hex socket button head	STD	standard
HSFH	hex socket flat head	TAP	self tapping
HSH	hex socket head	TTH	Torx truss head
HWH	hex washer head	WH	wing head
HWHTF	hex washer head thread forming		

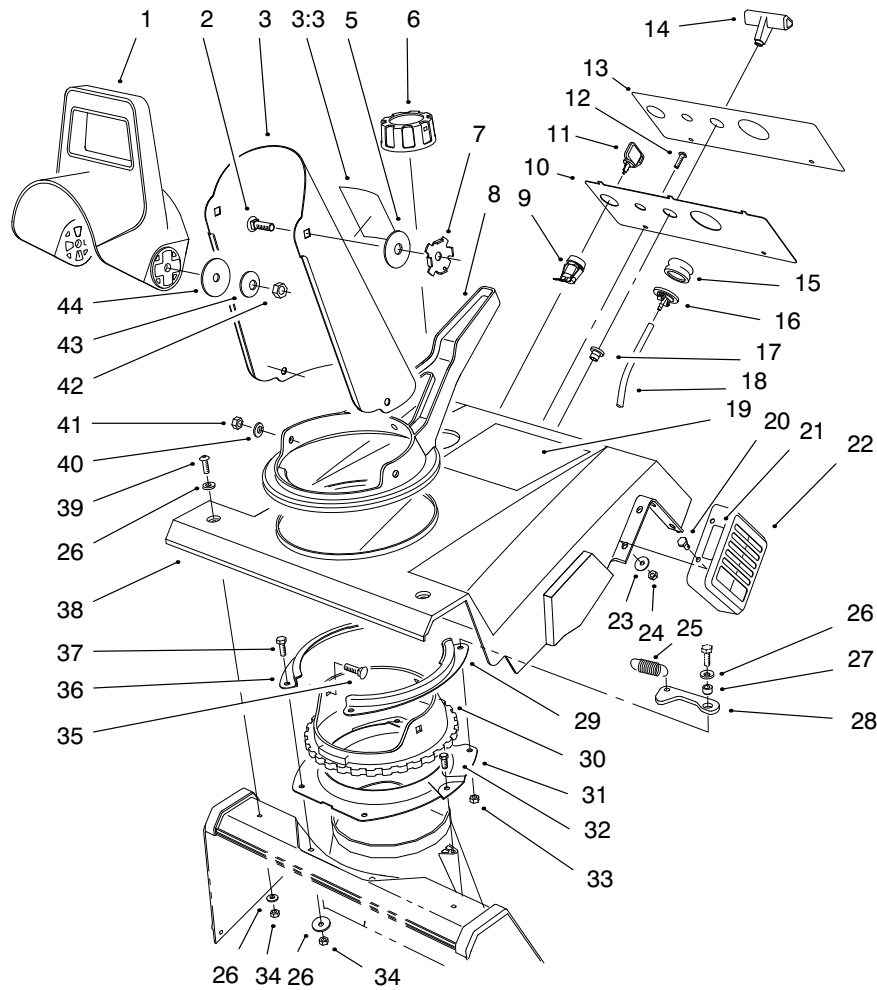

Sheet No.:2

Deflector & Control Panel Assembly

Ref. No.	Part No.	Qty.	Description
1	56-2680	1	Chute-Deflector
2	3230-22	2	Screw-CARR
3	94-2790	1	ASM - Chute w/Decal
3:3	94-2900	1	Decal - Danger Discharge
5	20-4320	2	Washer-Rubber
6	55-3573	1	ASM-Gas Cap
7	55-8950	2	Plate-Friction
8	71-4940	1	Chute - Handle
9	40-5940	1	On-Off Switch
10	71-5240-03	1	Control Panel (only on: 28220)
10	71-5241-03	1	Control Panel (only on: 28222)
11	700918	1	Key
12	32144-53	2	Screw-Self TAP
13	95-2666	1	Decal - Control Panel (only on: 28222)
13	95-2665	1	Decal - Control Panel (only on: 28220)
14	92-4853	1	Handle-Starter
15	66-7460	1	Bulb-Primer
16	44-2750	1	Body-Primer
17	23-7470	1	Starter Rope Guide
18	44-3173	1	Primer Hose

Ref. No.	Part No.	Qty.	Description
19	94-9878	1	Decal - 320 Recoil (only on: 28220)
19	94-9879	1	Decal - 320 Electric (only on: 28222)
20	3290-359	4	Screw-HWH
21	95-1904	1	Decal - Hot
22	71-5340-03	1	Muffler Guard
23	3256-61	4	Washer-Flat
24	3296-2	4	Nut-Lock Ni
25	80-4600	1	Spring - Detent
26	3256-22	7	Washer-Flat
27	55-9370	1	Rotor Bld Spacer
28	80-4610	1	Detent
29	71-4980-03	1	LH Chute Ring Retr
30	71-4950	1	Gear Ring, Chute
31	55-8921-03	1	Chute Supt Ring
32	46-8092	2	Plastite Screw
33	3296-56	1	Nut-Lock Ni
34	3296-42	5	Nut-Lock Ni
35	3230-16	3	Screw-HH
36	71-4990-03	1	RH Chute Ring Retr
37	321-4	4	Screw-HH
38	94-8888	1	Upper Shroud
39	3250-32	2	Screw-PPH
40	3256-70	3	Washer-Flat
41	32149-1	3	Nut-Keps

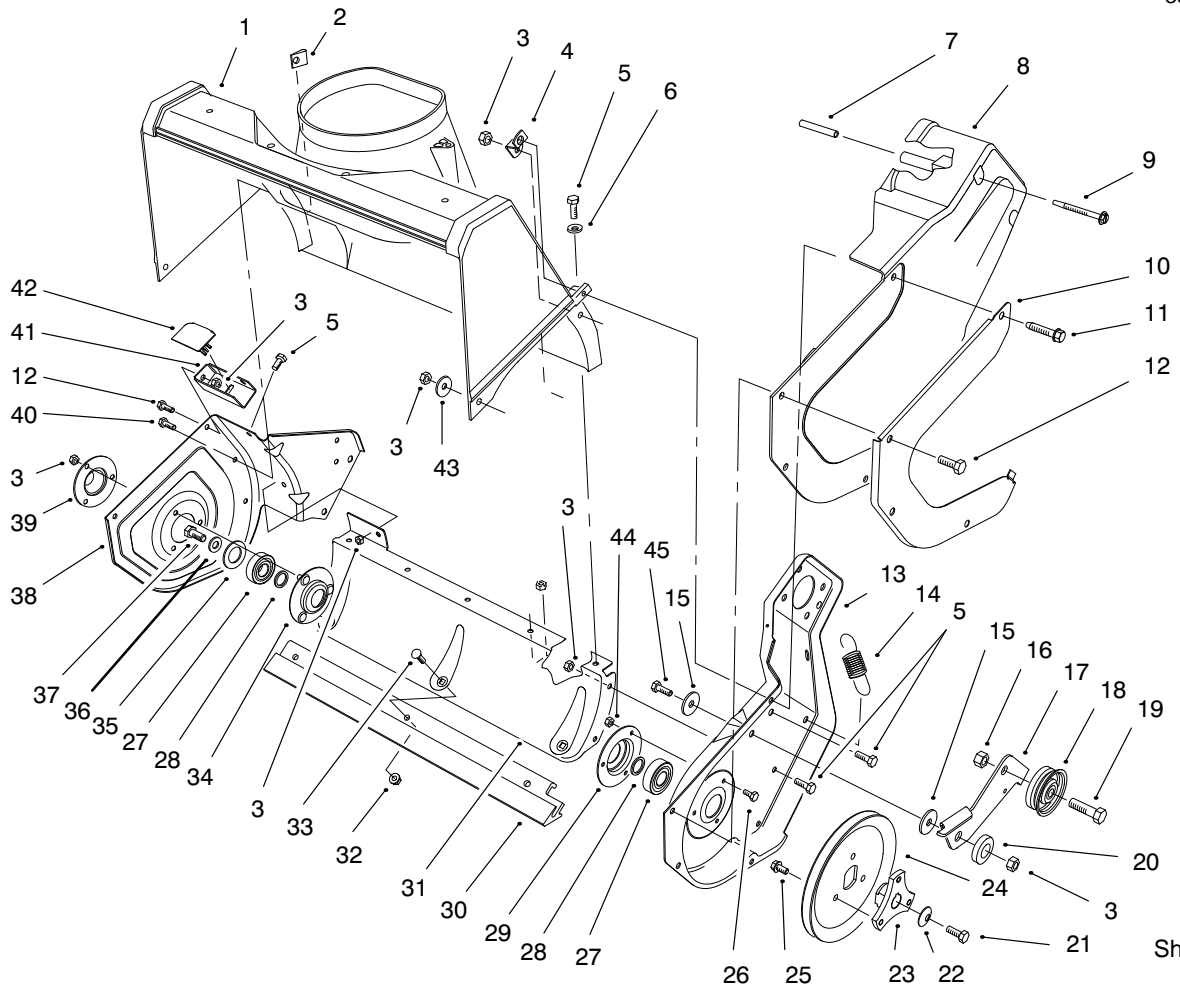

Sheet No.:3

Housing & Side Plate Assembly

Ref. No.	Part No.	Qty.	Description
1	55-8700	1	Housing
2	32115-14	1	Speed Nut
3	3296-42	21	Nut-Lock Ni
4	55-9430	1	Hsg Brkt
5	321-4	10	Screw-HH
6	3256-22	5	Washer-Flat
7	57-3830	2	Tubular Spacer
8	71-5030	1	Drive Cover
9	71-5350	2	Thread Forming Screw
10	71-5150-03	1	Edge Guard
11	36-3860	1	Spec Screw
12	32105-15	7	Screw-Machine
13	71-4911-03	1	Left Sideplate
14	71-5470	1	Brake Spring
15	3256-55	2	Washer-Flat
16	3296-39	1	Nut-Lock Ni
17	71-5160	1	Brake Arm Idler
18	71-5260	1	Idler Pulley
19	323-44	1	Screw-HH
20	80-4620	1	Spacer
21	321-30	1	Screw-HH
22	3290-456	1	Washer-Belleville
23	71-5070	1	Hub - Mtg, Pulley
24	71-5410	1	Rotor Pulley
25	12-3270	3	Screw
26	32105-8	3	Screw

Ref. No.	Part No.	Qty.	Description
27	38-7820	2	Bearing-Ball
28	52-7280	2	Thrust Washer
29	38-8620	1	Bearing Flange
30	71-5390	1	Scraper
31	71-4930-03	1	Lower Housing
32	32128-10	3	Flange Locknut
33	3229-11	3	Screw-CARR
34	52-9110	1	Brg Flange Wa
35	52-7270	1	Rubber Washer
36	3256-24	1	Washer-Flat
37	3234-25	1	Flange Bolt
38	71-4920-03	1	RH Sideplate
39	52-7290-03	1	Brg Retainer
40	321-39	1	Screw-HH
41	71-5310-03	1	Sideplate Brkt Supt
42	71-5270	1	Bracket Cover
43	3256-67	2	Washer-Flat
44	3296-2	3	Nut-Lock Ni
45	321-6	1	Screw-HH

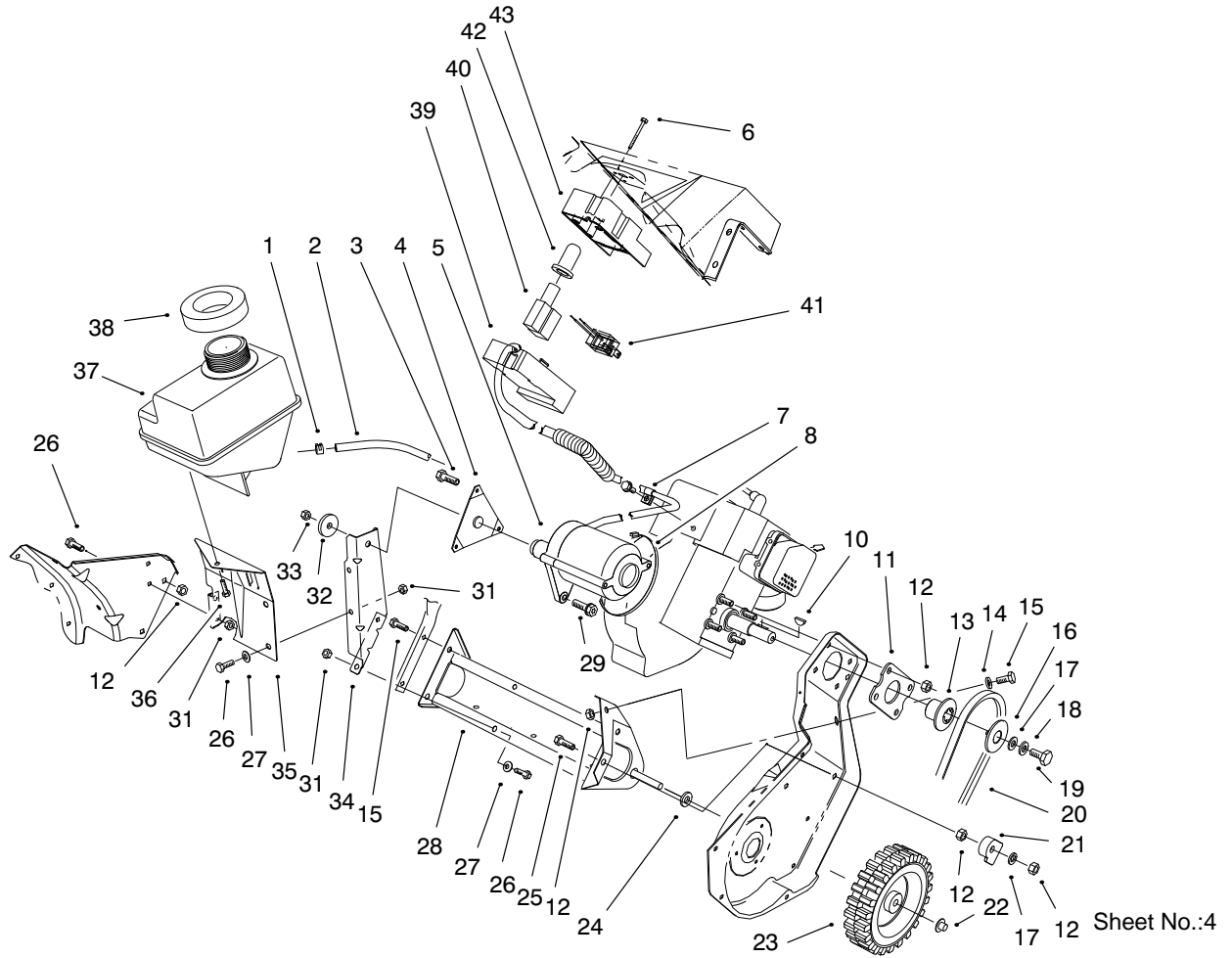

Engine & Gas Tank Assembly

Ref. No.	Part No.	Qty.	Description
1	2412-98	2	Clamp
2	49-2482	1	Gas Line
3	3255-10	1	Washer-Lock/Ext
3	92-6031	1	Screw
4	92-6012	1	Bracket/Stud ASM
5	77-0402	1	Starter Motor ASM [120 Volt] (only on: 28222)
6	32144-27	3	Screw-Plastite (only on: 28222)
7	2412-91	1	Clamp R (only on: 28222)
8	250-7	1	Tie-Cable
10	3257-3	1	Key-Woodruff
11	71-5290-03	1	Engine Plate
12	3296-29	8	Nut-Lock Ni
13	71-5050	1	Hub - Half Sheave
14	3256-23	1	Washer-Flat
15	322-3	3	Screw-HH
16	71-5060	1	Cap - Half Sheave
17	3256-71	2	Washer-Flat
18	3290-456	1	Washer-Belleville
19	3235-6	1	Screw-Hex Hd Cs
20	71-5381	1	Drive V-Belt
21	84-5610	1	Guide-Cable
22	3290-320	2	Retainer-Push On

Ref. No.	Part No.	Qty.	Description
23	23-3250	2	Wheel
24	71-5440	2	Wheel Spacer
25	322-5	1	Screw-HH
26	321-4	6	Screw-HH
27	3256-22	4	Washer-Flat
28	71-5200-03	1	Frame Wa
29	80-0700	2	Screw - Mtg Torx (only on: 28222)
31	3296-42	6	Nut-Lock Ni
32	71-5320	1	Engine Support Washer
33	3296-16	1	Nut-Lock Ni
34	71-5210-03	1	Engine Support
35	71-5220-03	1	Tank Bracket
36	32144-53	1	Screw-Self TAP
37	71-5020	1	Fuel Tank
38	55-9310	1	Foam Seal
39	100-3441	1	Base Housing Switch (only on: 28222)
40	61-4820	1	Switch, Starter (only on: 28222)
41	94-9933	1	Power Plug (only on: 28222)
42	61-4810	1	Boot, Switch (only on: 28222)

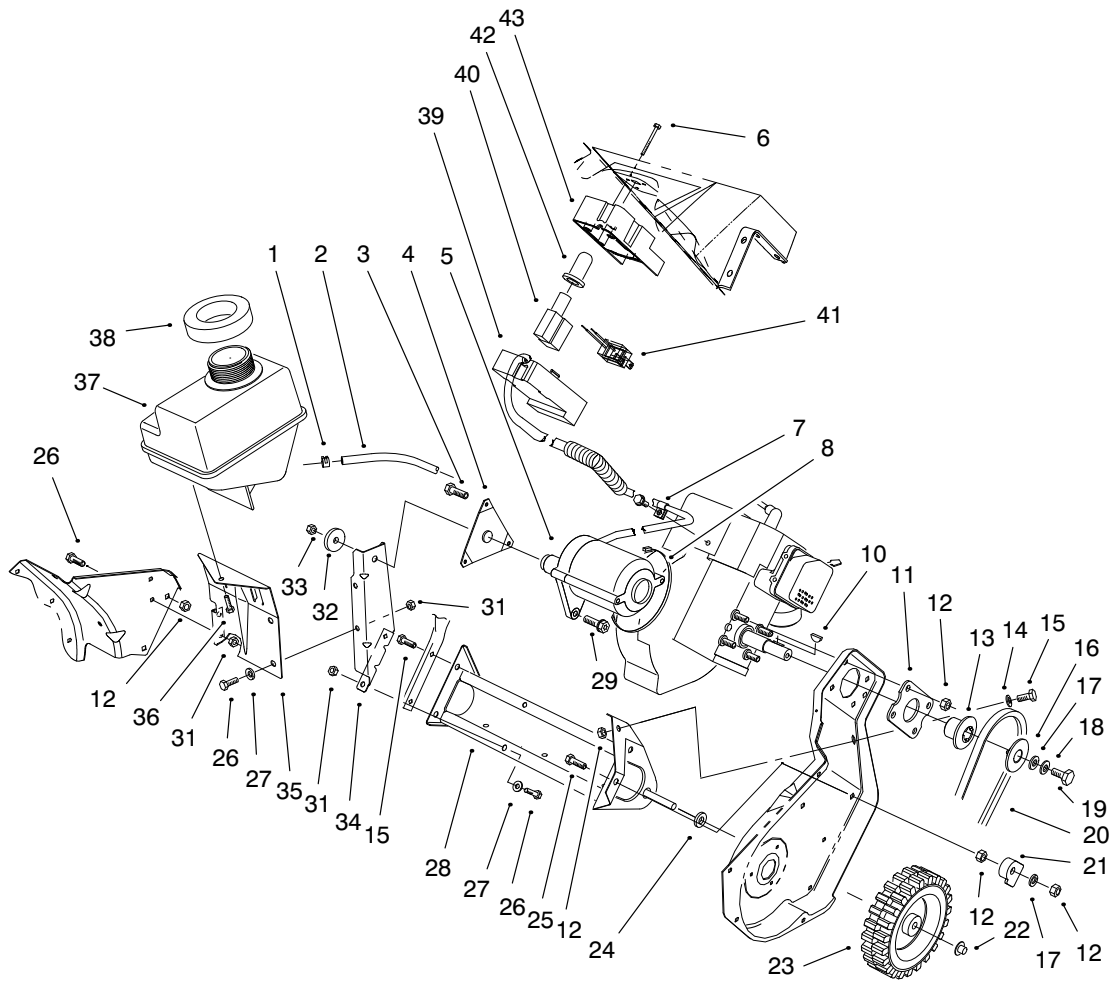

Sheet No.:4

Engine & Gas Tank Assembly (cont.)

Ref. No.	Part No.	Qty.	Description
43	100-3442	1	Cap Housing Switch (only on: 28222)
*99	28-9170	1	Cord (only on: 28222)

Ref. No.	Part No.	Qty.	Description

* Not illustrated

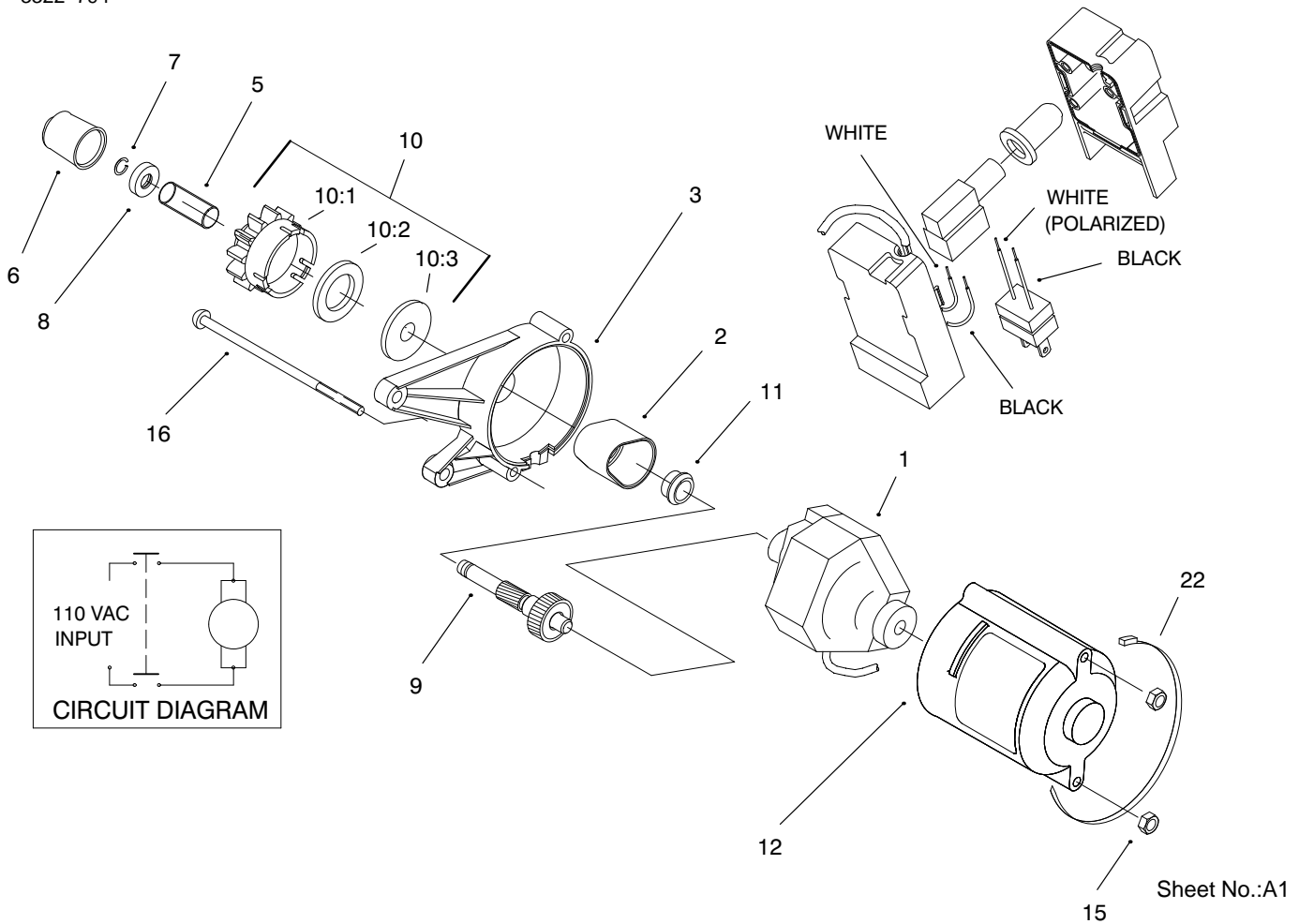

Motor & Switch Housing Assembly (120 Volt) (Model No. 28222 Only)

Ref. No.	Part No.	Qty.	Description
1	70-7802	1	Starter Motor Assembly (only on: 28222)
2	70-7850	1	Gear Cover (only on: 28222)
3	100-3443	1	Housing Upper Starter (only on: 28222)
5	61-4690	1	Spring (only on: 28222)
6	70-7890	1	Cap Pinion (only on: 28222)
7	61-4680	1	Lock Ring (only on: 28222)
8	100-2902	1	Pinion Stop (only on: 28222)
9	92-6003	1	Shaft/Gear ASM-Service (only on: 28222)
10	84-5240	1	Pinion ASM (R & S) (only on: 28222)
10:1	70-7790	1	Nut (only on: 28222)
10:2	84-5230	1	Pinion (only on: 28222)

Ref. No.	Part No.	Qty.	Description
10:3	84-5440	1	Ring - Rubber (only on: 28222)
11	70-7900	1	Bushing (only on: 28222)
12	100-3444	1	Housing Lower Starter (only on: 28222)
15	3296-2	2	Nut-Lock Ni (only on: 28222)
16	32144-101	2	Screw-Mach (only on: 28222)
22	250-7	1	Cable Tie (only on: 28222)

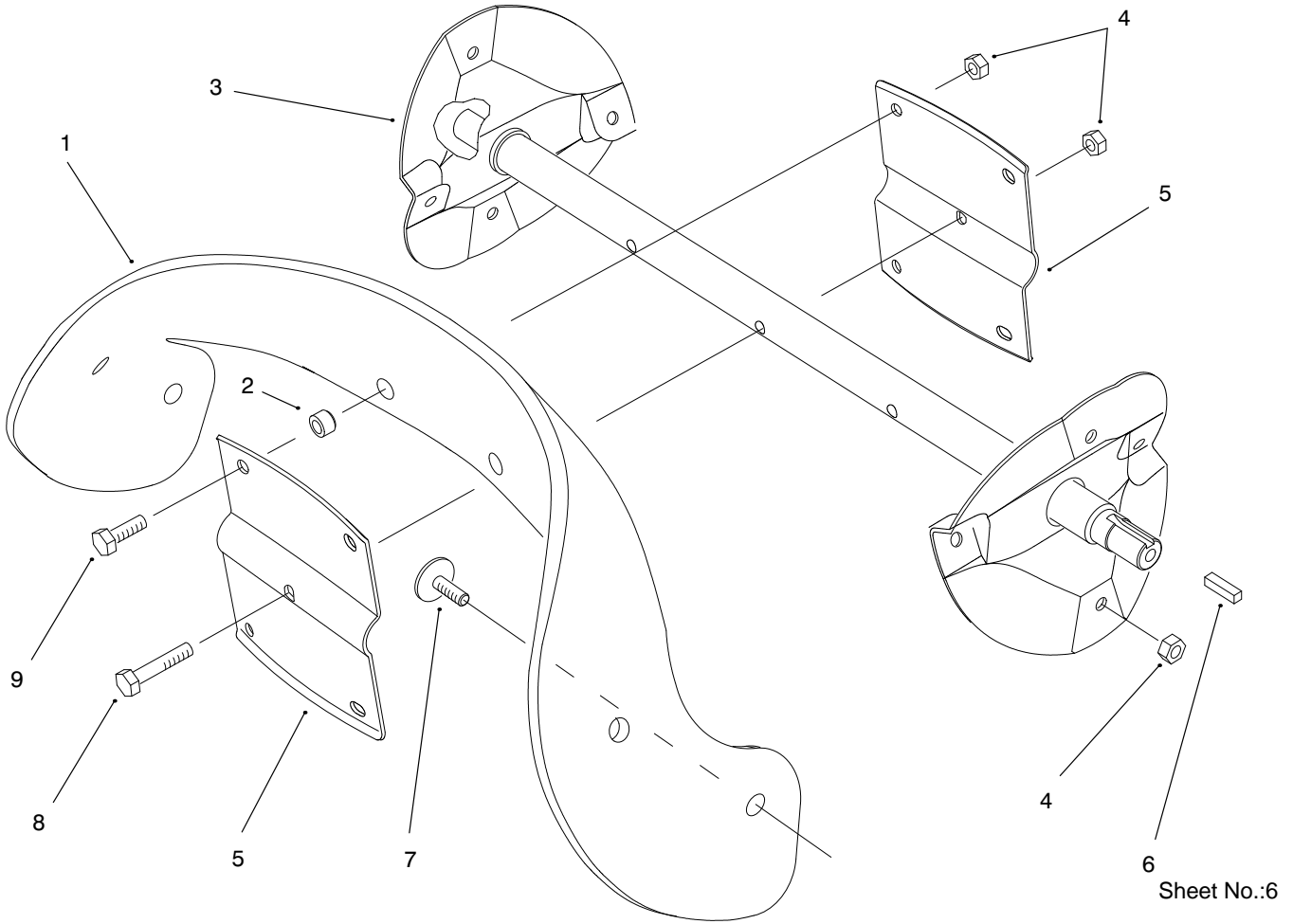

Sheet No.:6

Rotor Assembly

Ref. No.	Part No.	Qty.	Description
1	88-0781	2	Rotor Blade (Ccr 1000)
2	55-9370	4	Rotor Bld Spacer
3	55-9202-03	1	Rotor Wa
4	3296-56	13	Nut-Lock Ni
5	66-6600-03	2	Rotor Half
6	10-8040	1	Key-Square
7	84-1971	8	Screw-Csunk Oval
8	321-8	1	Screw-HH
9	321-4	4	Screw-HH

Ref. No.	Part No.	Qty.	Description

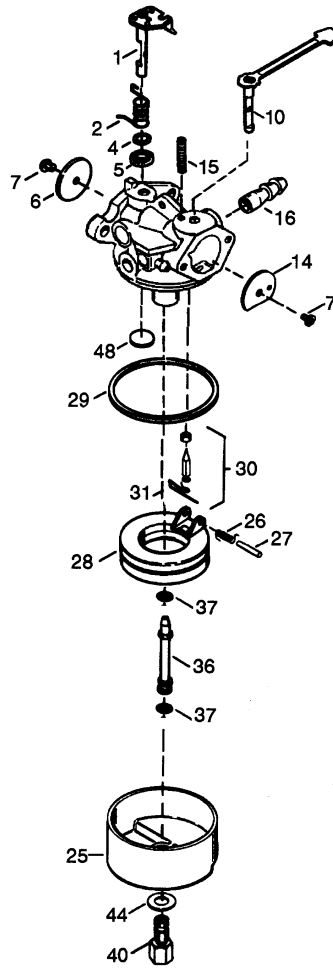

CARBURETOR NO. 640086

Ref. No.	Part No.	Description	No. Used	Ref. No.	Part No.	Description	No. Used
1	632166A	Throttle Shaft & Lever Asm.	1	27	631024	Float shaft	1
2	632169	Throttle Return Spring	1	28	632019	Float	1
4	631184	Dust Seat Washer	1	29	631028	Float Bowl "O" Ring	1
5	631183	Dust Seat (Throttle)	1	30	631021	Inlet Needle, Seat & Clip (Incl. Ref. #31)	1
6	631621	Throttle Shutter	1	31	631022	Spring Clip	1
7	650506	Shutter Screw	2	36	640080	Main Nozzle Tube	1
10	632553	Choke Shaft & Lever Asm.	1	37	632547	"O" Ring, Main Nozzle Tube	1
14	631815	Choke Shutter	1	40	640087	High Speed Bowl Nut	1
15	630735	Choke Positioning Spring	1	44	27110	Bowl Nut Washer	1
16	632164	Fuel Fitting	1	48	631027	Welch Plug	1
25	631700	Float Bowl	1				
26	632386	Float Dampening Spring	1				

ENGINE TECUMSEH MODEL NO. HSK600-1681T

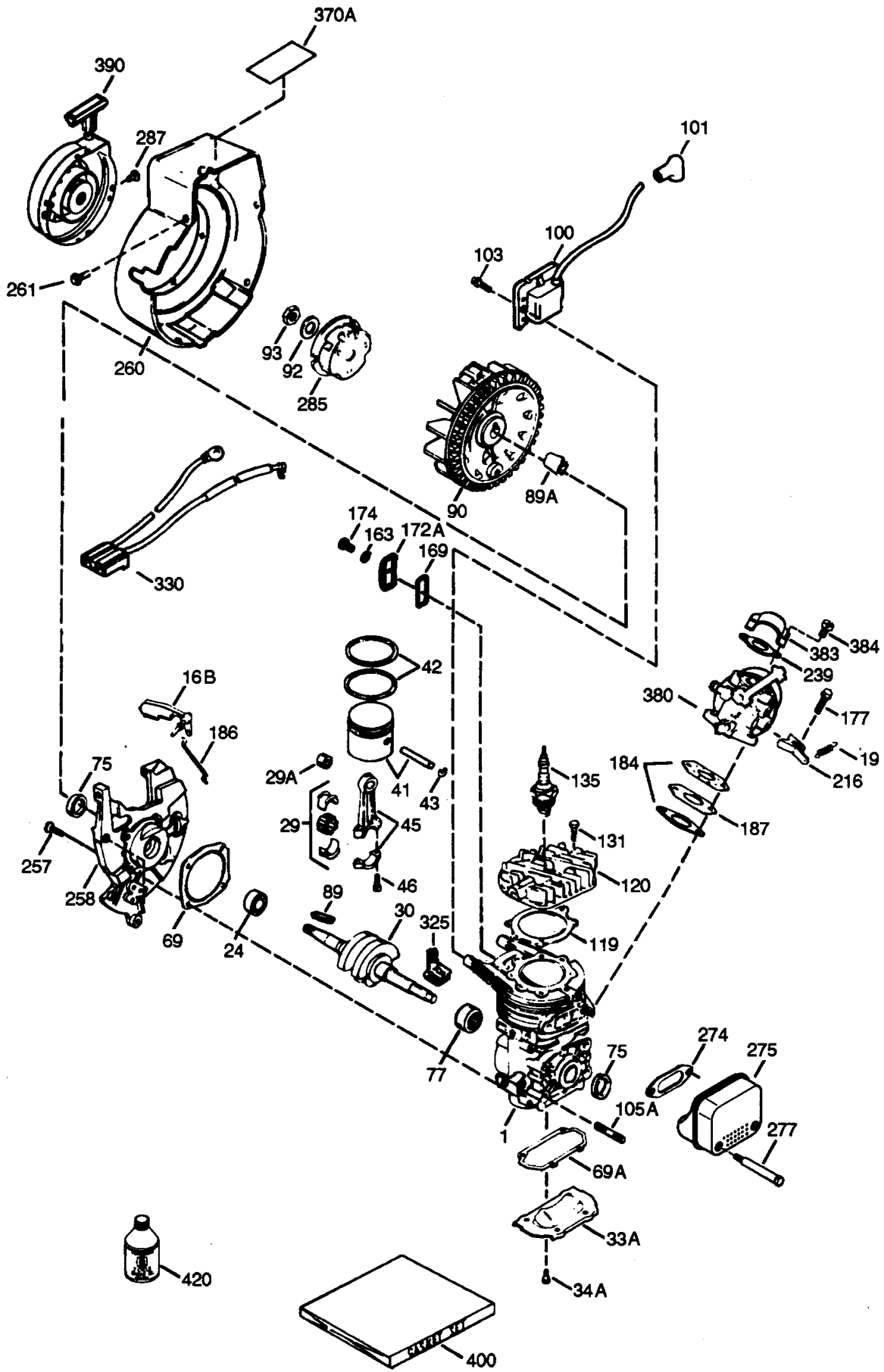

ENGINE TECUMSEH MODEL NO. HSK600-1681T

Ref. No.	Part No.	Description	No. Used	Ref. No.	Part No.	Description	No. Used
1		Cylinder (Order Short Block if Replacement is needed)	1	135	611049	Resistor Spark Plug	1
16B	490291A	Air Vane	1	163	650838	Washer	1
19	570707	Extension Spring	1	*169	510325A	Cover Plate Gasket	1
24	530110	Ball Bearing	1	172A	570708	Compression Release Cover	1
29	530150	Needle Bearing & Liner Set (37 Needles)	1	174	650579	Screw, Torx T-25	1
29A	530104A	Cartridge Bearing	1	177	650959	Screw	2
30	290602	Crankshaft	1	*184	510326A	Carburetor Gasket	2
33A	570644	Cover Plate	1	186	490322	Governor Link	1
34A	650579	Screw, Torx T-25	4	187	570438A	Spacer	1
41	310283A	Piston & Pin Assembly	1	216	570645	R.P.M. Adjusting Lever	1
42	310190	Ring Set	2	239	35815	Air Cleaner Gasket	1
43	310167	Piston Pin Retaining Ring	2	257	650911	Screw, Torx T-30	4
45	310235B	Connecting Rod Assembly (Incl. Ref. #29, 29A, & 46)	1	258	350422	Blower Housing Base (Incl. Ref. #27)	1
46	650633	Connecting Rod Bolt	4	260	350437	Blower Housing	1
*69	510292A	Cylinder Cover Gasket	1	261	650737	Screw	4
*69A	510323A	Cover Plate Gasket	1	*274	510346A	Exhaust Gasket	1
75	510319	Oil Seal	2	275	390330	Muffler (Incl. Ref. #274 & 277)	1
77	530105	Cartridge Bearing	1	277	650869	Screw	2
89A	611032	Adapter Sleeve	1	285	590551A	Starter Cup	1
90	611066	Flywheel	1	287	650926	Screw	3
92	650815	Belleville Washer	1	325	29443	Wire Clip	1
93	650390	Flywheel Nutt	1	330	611153	Wire Harness	1
100	34443A	Solid State Ignition (Incl. Ref. #101)	1	370A	36261	Instruction Decal	1
101	610118	Spark Plug Cover	1	380	640086	Carburetor (Incl. Ref. #184)	1
103	651007	Screw, Torx T-15	2	383	570434	Spit Cup	1
105A	650796	Stud	4	384	650431	Screw, Torx T-25	2
*119	510274A	Cylinder Head Gasket	1	390	590743	Rewind Starter	
120	250240B	Cylinder Head	1	400	510324B	Gasket Set	1
131	650477	Screw, Torx T-30	5	420	730227A	2-Cycle Oil (8 oz.)	1

*Included in Gasket Set No. 510324B

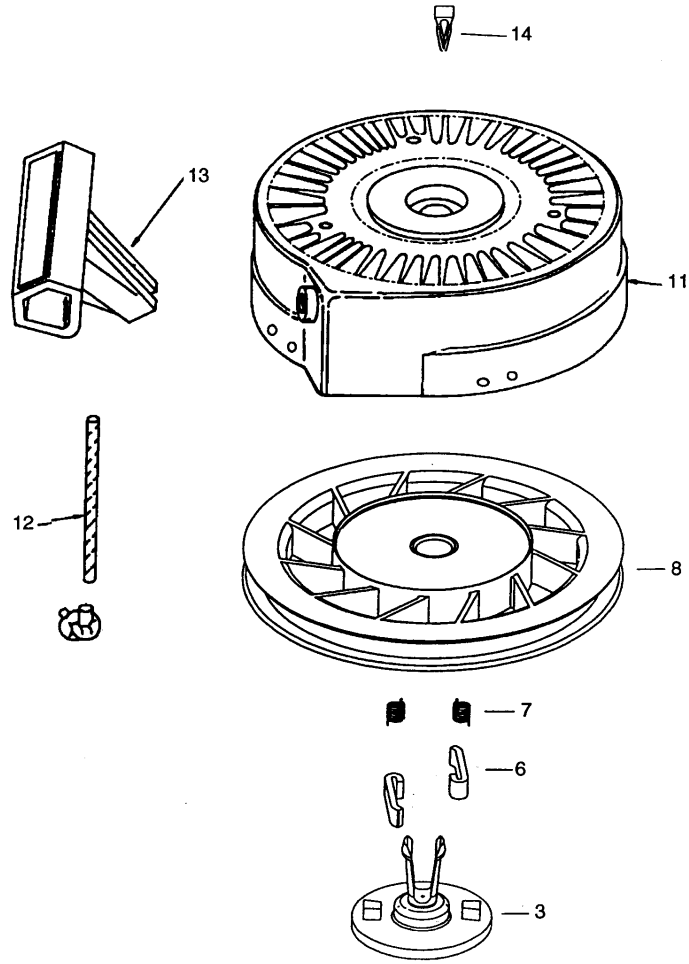

RECOIL STARTER NO. 590743

Ref. No.	Part No.	Description	No. Used	Ref. No.	Part No.	Description	No. Used
0	590743	Rewind Starter	1	11	590643	Starter Housing Ass'y	1
3	590740	Retainer	1	12	590535	Starter Rope (Length 98" x 9/64" Dia.)	1
6	590616	Starter Dog	2	13	590701	Starter Handle	1
7	590617	Dog Spring	2	14	590741	Locking Tab	1
8	590645A	Pulley & Rewind Spring Ass'y	1				

LAWN-BOY®