



Wheel Horse<sup>®</sup>  
**52" Deck and Recycler<sup>®</sup>**  
**Assembly**

Model No. 78280 – 6900001 & Up  
Model No. 78285 – 6900001 & Up

---

**Parts Catalog**

## ORDERING REPLACEMENT PARTS

To order replacement parts, please supply: the part number, the quantity, and the description of each part desired.

## Contents

Description	Page	Description	Page
Gage Wheels and Lift Brackets .....	1	Decals and Baffles .....	4
Blades, Spindles and Deflectors .....	2	Decals and Baffles .....	5
Drive & Belt Covers .....	3	<b>Note:</b>	

## Part Description Abbreviations

Part descriptions in this catalog may include the following abbreviations.

Abbreviation	Meaning	Abbreviation	Meaning
AR .....	as required	INC .....	incorporated
ASM .....	assembly	LH .....	left hand
CARR .....	carriage	NI .....	nylon insert
DEG .....	degrees	PPH .....	Phillips pan head
FH .....	flat head	PTH .....	Phillips truss head
GA .....	gauge	PTO .....	power take off
HF .....	hex flange	RH .....	right hand
HH .....	hex head	SFH .....	slotted fillister head
HHF .....	hex head flange	SHH .....	slotted hex head
HLH .....	hex lag head	SQH .....	square head
HJ .....	hex jam	SHWH .....	slotted hex washer head
HOC .....	height-of-cut	SPH .....	slotted pan head
HS .....	hex socket	SRH .....	slotted round head
HSBH .....	hex socket button head	STD .....	standard
HSFH .....	hex socket flat head	TAP .....	self tapping
HSH .....	hex socket head	TTH .....	Torx truss head
HWH .....	hex washer head	WH .....	wing head
HWHTF .....	hex washer head thread forming		

## Important Format Explanations

This catalog uses special formats to convey information in illustrations and parts lists. Specifically, one format is used in conjunction with service assemblies and another with quantities associated with reference numbers.

### Service Assemblies

Parts within service assemblies have reference numbers in the form X:Y. X is the reference number of the service assembly and Y is a sequential number unique to each part within the service assembly.

For example, a wheel assembly might be identified by reference number 6, the tire by 6:1, the valve by 6:2, and the wheel by 6:3. When you order the assembly identified by reference number 6, you receive all parts identified by reference numbers 6:1, 6:2, and 6:3. However, you may also order any part individually.

Reference numbers of this type appear in part lists and as callouts in illustrations.

## Reference Numbers with Quantities

Illustrations may have a quantity in parentheses next to a reference number, in the form  $X (Y)$ .  $X$  is the reference number.  $Y$  in parentheses is the quantity of the part identified by the reference number.

For example, the illustration callout 4 (2) indicates that two parts are used in that instance.

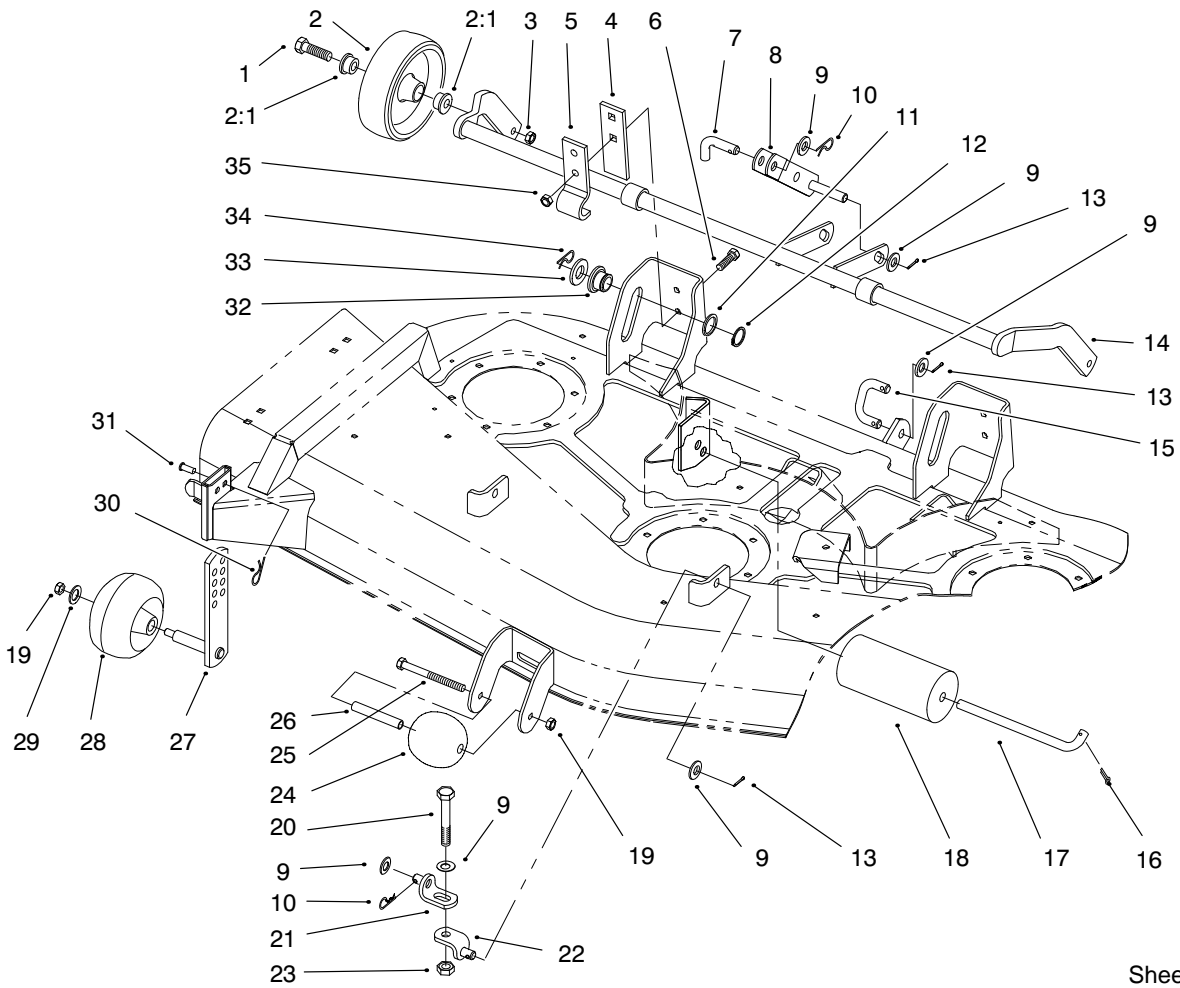

Sheet No.: 2

## Gage Wheels and Lift Brackets

Ref. No.	Part No.	Qty.	Description
1	5188	2	Bolt-Shoulder
2	110506	2	Wheel
2:1	5306	2	Bearing
3	32146-2	2	Nut-Lock NI
4	110838-03	2	Bar
5	110837-03	2	Pivot-Bracket
6	323-7	4	Screw-HH
7	94-4809	1	Pin - Link
8	94-4806-03	1	Lift Arm Assembly
9	3256-26	11	Washer-Flat
10	9335064	3	Hair Pin Cotter
11	9202394	2	Washer
12	32151-29	2	Ring-External Snap
13	3272-21	6	Pin-Cotter
14	94-2525-03	1	Wheel Carrier Assembly
15	94-4805	1	Link - Rear
16	3272-11	2	Pin-Cotter
17	40-0340	2	Rear Roller Shaft
18	36-1740	2	Roller-Deck
19	3296-39	3	Nut-Lock NI
20	325-13	2	Screw-HH
21	86-9240	2	Bracket-Lift, Lower
22	86-9250	2	Bracket-Lift, Upper
23	3218-5	2	Nut-Jam
24	29-4820	1	Roller

Ref. No.	Part No.	Qty.	Description
25	323-16	1	Screw-HH
26	94-2500	1	Tube - Wheel Spacer
27	68-2350	2	Gagewheel
28	68-2730	2	Gage Wheel
29	3256-24	2	Washer-Flat
30	9335054	2	Pin-Hair Cotter
31	283-2	2	Pin-Clevis
32	78-7340	2	Roller-Lift
33	3256-28	2	Washer-Flat
34	9335074	2	Pin-Cotter
35	32128-21	4	Nut-Flange Lock

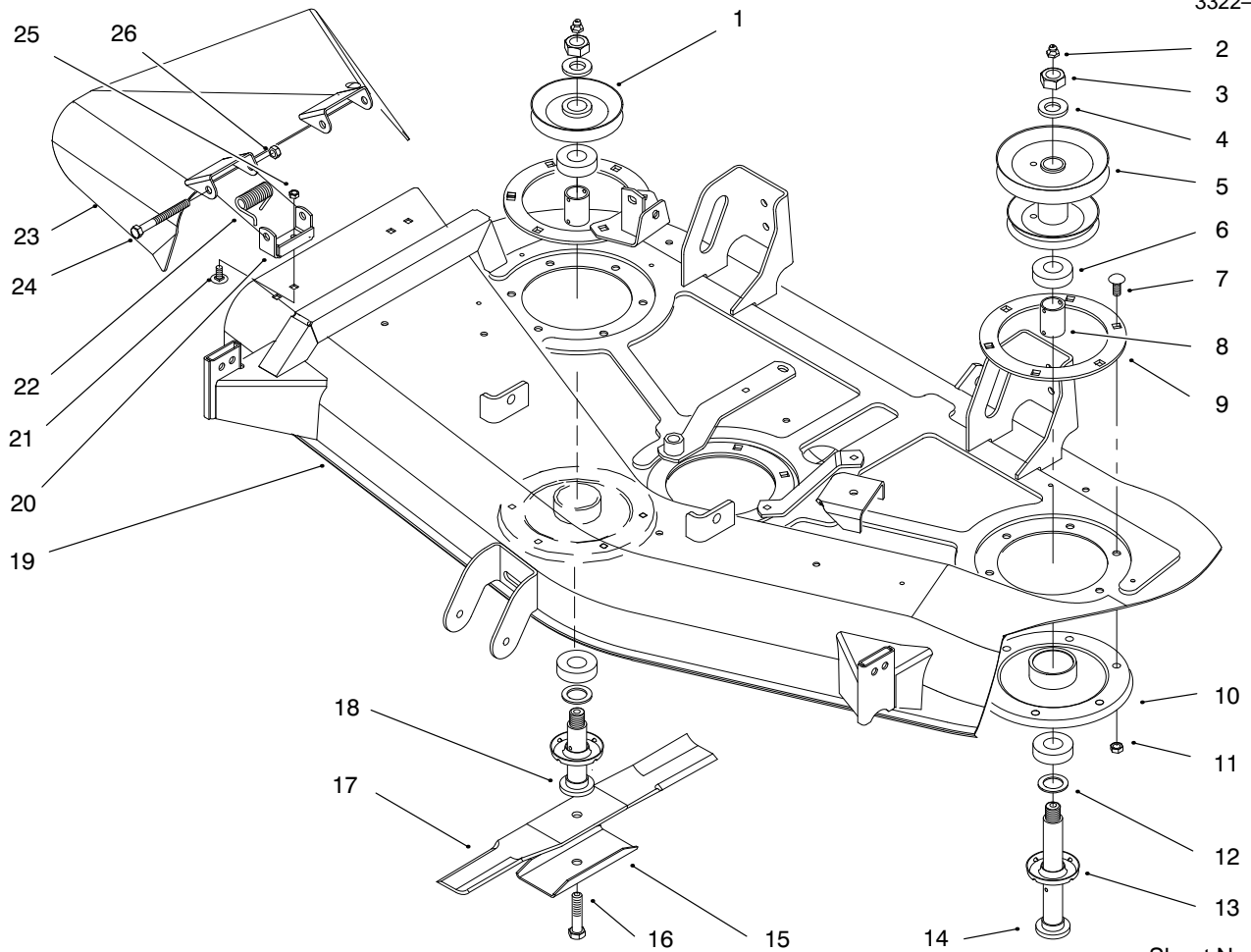

Sheet No.: 3

## Blades, Spindles and Deflectors

Ref. No.	Part No.	Qty.	Description
1	79-0620	2	Pulley
2	302-2	3	Fitting-Grease
3	3220-7	3	Nut-Jam
4	3256-28	3	Washer-Flat
5	94-4800	1	Pulley - Double
6	113514	6	Bearing
7	3231-22	14	Screw-CARR
8	79-1890	3	Spacer-Bearing
9	27-7680-03	3	Ring-Deck Support
10	79-2480-03	3	Housing-Spindle
11	32128-21	14	Nut-Flange Lock
12	88-7540	3	Washer - Backup
13	79-1920	3	Shield-Brg
14	94-2523	1	Shaft - Spindle
15	92-9820	3	Stiffener - Blade
16	44-2200	3	Blade Screw
17	27-0990	3	Blade (Only On: 78280)
17	92-7961	3	Blade (Only On: 78285)
18	79-1900	2	Shaft-Spindle Center
19	99-8019	1	Assembly-52 Deck w/Decals
20	29-5590-03	2	Bracket-Pivot
21	3230-18	4	Screw-CARR
22	40-6230	2	Spring

Ref. No.	Part No.	Qty.	Description
23	94-1580	1	Assembly-Deflector Decal
24	3211-15	2	Screw-HH
25	3296-29	4	Nut-Lock NI
26	3296-5	2	Nut-Lock NI

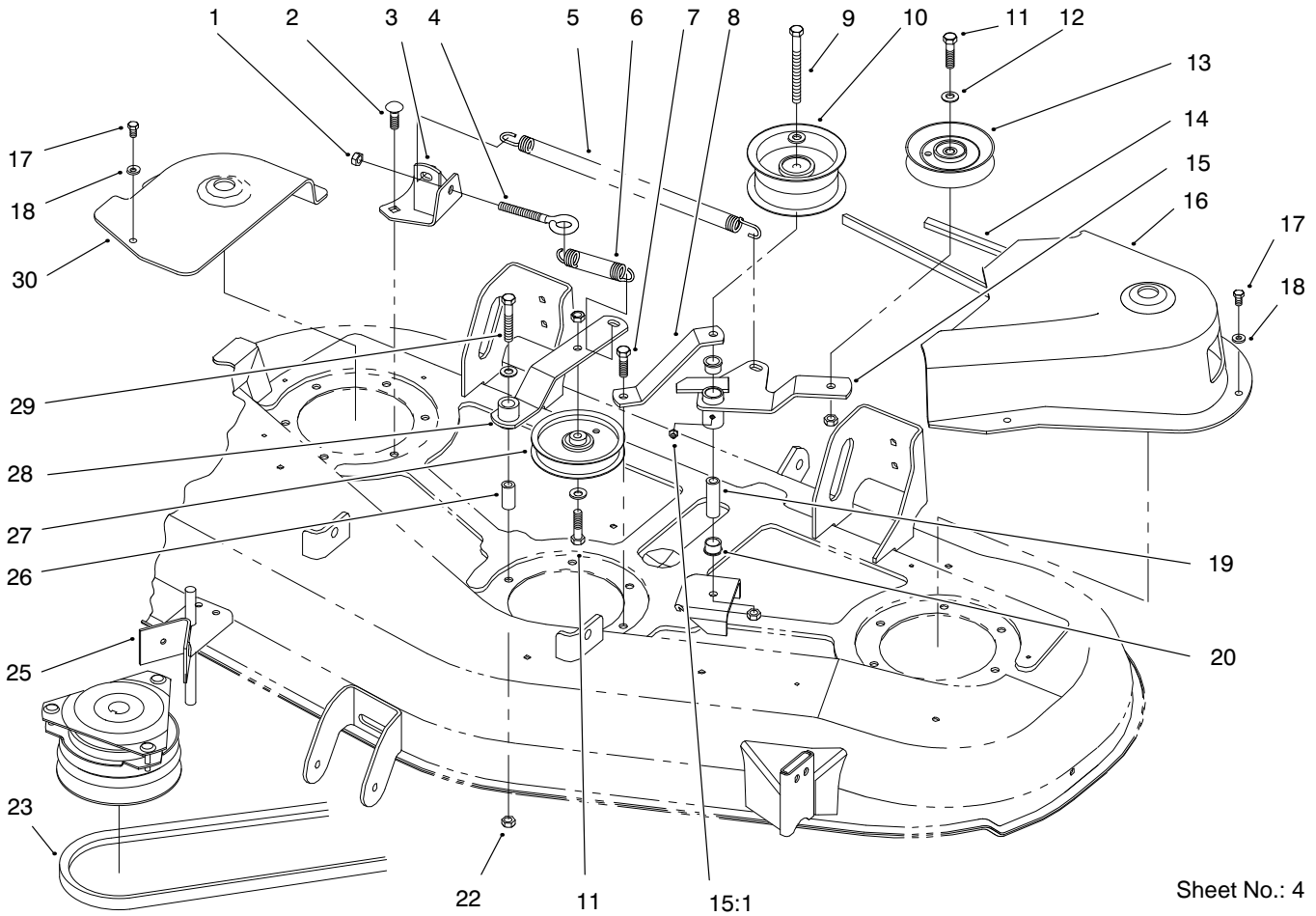

Sheet No.: 4

## Drive & Belt Covers

Ref. No.	Part No.	Qty.	Description
1	3296-39	1	Nut-Lock NI
2	3231-22	2	Screw-CARR
3	94-2546-03	1	Bracket-Spring
4	94-2547	1	Eyebolt
5	94-5385	1	Spring - Extension
6	51-3650	1	Spring - Extension
7	323-44	1	Screw-HH
8	94-4801-03	1	Strap-Support
9	323-16	1	Screw-HH
10	94-4935	1	Pulley - Idler
11	323-8	2	Screw-HH
12	3256-24	4	Washer-Flat
13	92-7099	1	Pulley - Idler
14	94-2501	1	Belt - V
15	95-7897	1	Idler Arm Assembly
15:1	302-5	1	Fitting-Lube
16	94-2522	1	Cover - Belt, LH
17	32144-4	6	Screw-HH
18	3256-22	6	Washer-Flat
19	79-2760	1	Spacer
20	109859	2	Bushing
22	32128-21	7	Nut-Flange Lock
23	94-2513	1	Belt - V
25	94-4940-03	1	Deck Upstop Assembly
26	51-3640	1	Idler Pivot Sleeve
27	93-1622	1	Pulley-Idler

Ref. No.	Part No.	Qty.	Description
28	55-7640-03	1	Idler Arm
29	323-11	1	Screw-HH
30	94-2524	1	Cover - Belt, RH

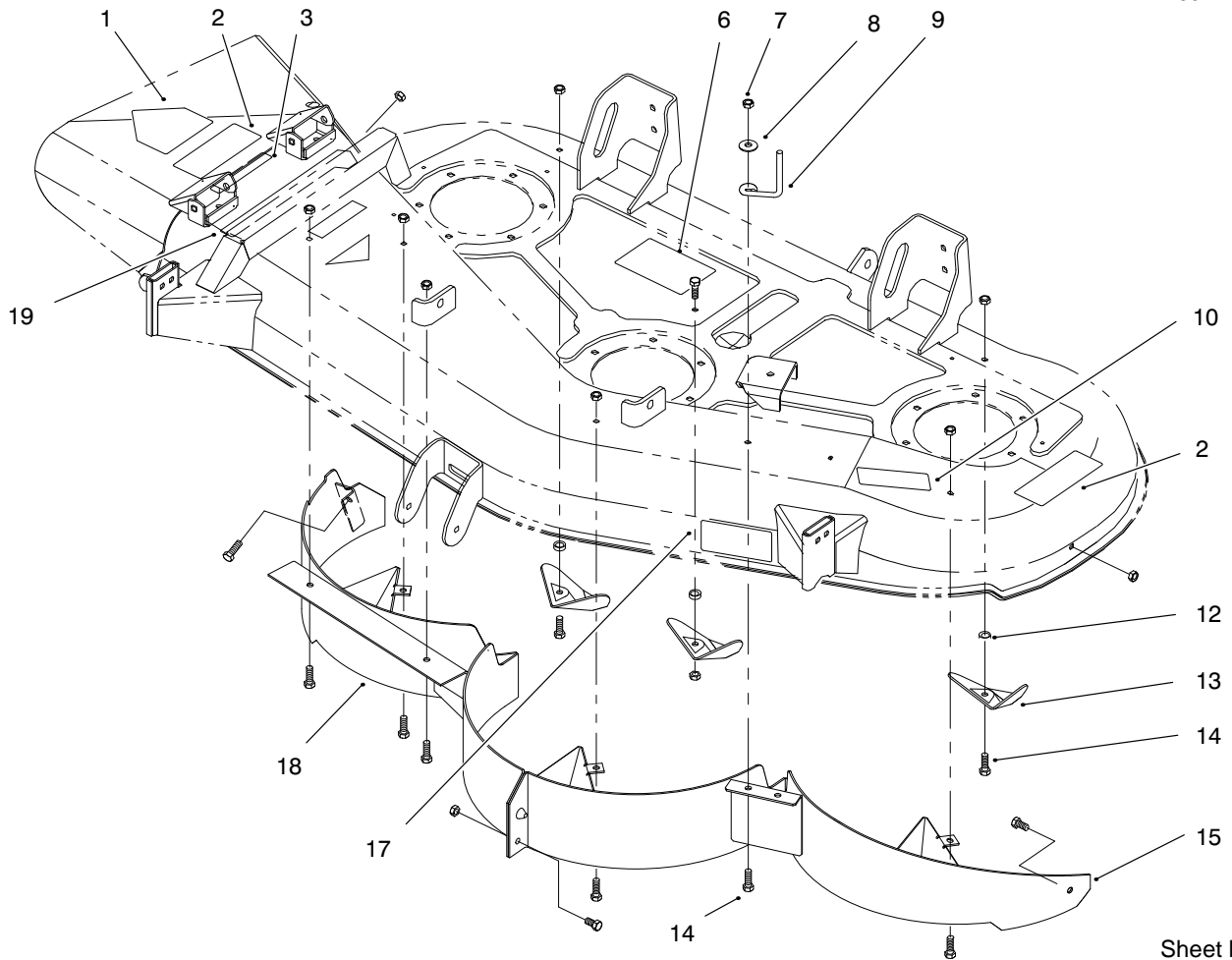

Sheet No.: 5

## Decals and Baffles

Ref. No.	Part No.	Qty.	Description
1	93-1122	1	Decal – Danger (Only On: 78285)
2	92-7108	2	Decal – Danger (Only On: 78285)
3	92-7109	1	Decal – Caution (Only On: 78285)
6	94-4937	1	Decal – Belt Routing (Only On: 78285)
7	3296-29	12	Nut–Lock NI (Only On: 78285)
8	3256-23	1	Washer–Flat (Only On: 78285)
9	94-2535	1	Guide – Belt (Only On: 78285)
10	94-2543	1	Decal – Belt Routing (Only On: 78285)
12	59-4310	3	Spacer (Only On: 78285)
13	84-5760	3	Kicker Plate (Only On: 78285)
14	322-5	4	Screw–HH (Only On: 78285)
15	94-2505-03	1	Left Baffle Assembly (Only On: 78285)
16	322-2	8	Screw–HH (Only On: 78285)

Ref. No.	Part No.	Qty.	Description
17	93-7282	1	Decal–Wheel Adjustment (Only On: 78285)
18	94-2504-03	1	Right Baffle Assembly (Only On: 78285)
19	94-4943	1	Decal – Deck (Only On: 78285)

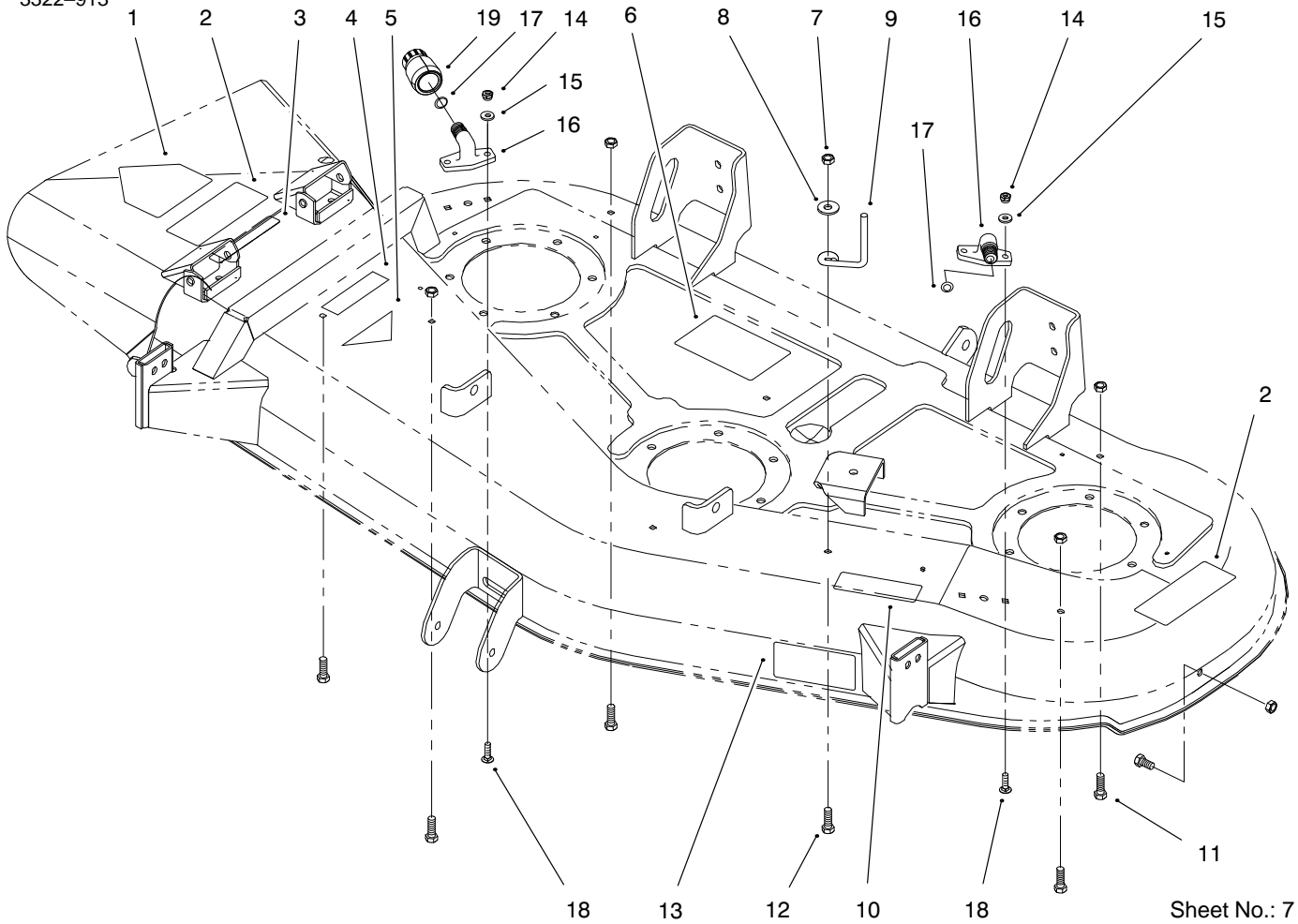

### Decals and Baffles

Ref. No.	Part No.	Qty.	Description
1	93-1122	1	Decal - Danger (Only On: 78280)
2	92-7108	2	Decal - Danger (Only On: 78280)
3	92-7109	1	Decal - Caution (Only On: 78280)
6	94-4937	1	Decal - Belt Routing (Only On: 78280)
7	3296-29	7	Nut-Lock NI (Only On: 78280)
8	3256-23	1	Washer-Flat (Only On: 78280)
9	94-2535	1	Guide - Belt (Only On: 78280)
10	94-2543	1	Decal - Belt Routing (Only On: 78280)
11	322-2	6	Screw-HH (Only On: 78280)
12	322-5	1	Screw-HH (Only On: 78280)
13	93-7282	1	Decal-Wheel Adjustment (Only On: 78280)
14	3296-16	4	Nut-Lock NI
15	3256-1	4	Washer-Flat
16	95-2747	2	Fitting - Washout

Ref. No.	Part No.	Qty.	Description
17	46-6290	2	O-Ring
18	3229-1	4	Screw-CARR
19	95-3270	1	Connector-Hose

# Toro Part Number Index

Part No.	Page No.	Ref. No.	Qty.	Description
5188	1	1	2	Bolt-Shoulder
5306	1	2:1	2	Bearing
109859	3	20	2	Bushing
110506	1	2	2	Wheel
113514	2	6	6	Bearing
9202394	1	11	2	Washer
9335054	1	30	2	Pin-Hair Cotter
9335064	1	10	3	Hair Pin Cotter
9335074	1	34	2	Pin-Cotter
27-0990	2	17	3	Blade (Only On: 78280)
27-7680-03	2	9	3	Ring-Deck Support
29-4820	1	24	1	Roller
29-5590-03	2	20	2	Bracket-Pivot
36-1740	1	18	2	Roller-Deck
40-0340	1	17	2	Rear Roller Shaft
40-6230	2	22	2	Spring
44-2200	2	16	3	Blade Screw
46-6290	5	17	2	O-Ring
51-3640	3	26	1	Idler Pivot Sleeve
51-3650	3	6	1	Spring - Extension
55-7640-03	3	28	1	Idler Arm
59-4310	4	12	3	Spacer (Only On: 78285)
68-2350	1	27	2	Gagewheel
68-2730	1	28	2	Gage Wheel
78-7340	1	32	2	Roller-Lift
79-0620	2	1	2	Pulley
79-1890	2	8	3	Spacer-Bearing
79-1900	2	18	2	Shaft-Spindle Center
79-1920	2	13	3	Shield-Brg
79-2480-03	2	10	3	Housing-Spindle
79-2760	3	19	1	Spacer
84-5760	4	13	3	Kicker Plate (Only On: 78285)
86-9240	1	21	2	Bracket-Lift, Lower
86-9250	1	22	2	Bracket-Lift, Upper
88-7540	2	12	3	Washer - Backup
92-7099	3	13	1	Pulley - Idler
92-7108	5	2	2	Decal - Danger (Only On: 78280)
92-7108	4	2	2	Decal - Danger (Only On: 78285)
92-7109	5	3	1	Decal - Caution (Only On: 78280)
92-7109	4	3	1	Decal - Caution (Only On: 78285)
92-7961	2	17	3	Blade (Only On: 78285)
92-9820	2	15	3	Stiffener - Blade
93-1122	5	1	1	Decal - Danger (Only On: 78280)
93-1122	4	1	1	Decal - Danger (Only On: 78285)
93-1622	3	27	1	Pulley-Idler
93-7282	5	13	1	Decal-Wheel Adjustment (Only On: 78280)
93-7282	4	17	1	Decal-Wheel Adjustment (Only On: 78285)
94-1580	2	23	1	Assembly-Deflector Decal
94-2500	1	26	1	Tube - Wheel Spacer
94-2501	3	14	1	Belt - V
94-2504-03	4	18	1	Right Baffle Assembly (Only On: 78285)
94-2505-03	4	15	1	Left Baffle Assembly (Only On: 78285)
94-2513	3	23	1	Belt - V
94-2522	3	16	1	Cover - Belt, LH
94-2523	2	14	1	Shaft - Spindle
94-2524	3	30	1	Cover - Belt, RH
94-2525-03	1	14	1	Wheel Carrier Assembly
94-2535	5	9	1	Guide - Belt (Only On: 78280)
94-2535	4	9	1	Guide - Belt (Only On: 78285)
94-2543	5	10	1	Decal - Belt Routing (Only On: 78280)
94-2543	4	10	1	Decal - Belt Routing (Only On: 78285)
94-2546-03	3	3	1	Bracket-Spring
94-2547	3	4	1	Eyebolt
94-4800	2	5	1	Pulley - Double
94-4801-03	3	8	1	Strap-Support
94-4805	1	15	1	Link - Rear
94-4806-03	1	8	1	Lift Arm Assembly
94-4809	1	7	1	Pin - Link

\*Not Illustrated

# Toro Part Number Index (cont.)

Part No.	Page No.	Ref. No.	Qty.	Description
94-4935	3	10	1	Pulley - Idler
94-4937	5	6	1	Decal - Belt Routing (Only On: 78280)
94-4937	4	6	1	Decal - Belt Routing (Only On: 78285)
94-4940-03	3	25	1	Deck Upstop Assembly
94-4943	4	19	1	Decal - Deck (Only On: 78285)
94-5385	3	5	1	Spring - Extension
95-2747	5	16	2	Fitting - Washout
95-3270	5	19	1	Connector-Hose
95-7897	3	15	1	Idler Arm Assembly
99-8019	2	19	1	Assembly-52 Deck w/Decals
110837-03	1	5	2	Pivot-Bracket
110838-03	1	4	2	Bar
283-2	1	31	2	Pin-Clevis
302-2	2	2	3	Fitting-Grease
302-5	3	15:1	1	Fitting-Lube
322-2	5	11	6	Screw-HH (Only On: 78280)
322-2	4	16	8	Screw-HH (Only On: 78285)
322-5	5	12	1	Screw-HH (Only On: 78280)
322-5	4	14	4	Screw-HH (Only On: 78285)
323-7	1	6	4	Screw-HH
323-8	3	11	2	Screw-HH
323-11	3	29	1	Screw-HH
323-16	1	25	1	Screw-HH
323-16	3	9	1	Screw-HH
323-44	3	7	1	Screw-HH
325-13	1	20	2	Screw-HH
3211-15	2	24	2	Screw-HH
3218-5	1	23	2	Nut-Jam
3220-7	2	3	3	Nut-Jam
3229-1	5	18	4	Screw-CARR
3230-18	2	21	4	Screw-CARR
3231-22	2	7	14	Screw-CARR
3231-22	3	2	2	Screw-CARR
3256-1	5	15	4	Washer-Flat
3256-22	3	18	6	Washer-Flat
3256-23	5	8	1	Washer-Flat (Only On: 78280)
3256-23	4	8	1	Washer-Flat (Only On: 78285)
3256-24	1	29	2	Washer-Flat
3256-24	3	12	4	Washer-Flat
3256-26	1	9	11	Washer-Flat
3256-28	1	33	2	Washer-Flat
3256-28	2	4	3	Washer-Flat
3272-11	1	16	2	Pin-Cotter
3272-21	1	13	6	Pin-Cotter
3296-5	2	26	2	Nut-Lock NI
3296-16	5	14	4	Nut-Lock NI
3296-29	2	25	4	Nut-Lock NI
3296-29	5	7	7	Nut-Lock NI (Only On: 78280)
3296-29	4	7	12	Nut-Lock NI (Only On: 78285)
3296-39	1	19	3	Nut-Lock NI
3296-39	3	1	1	Nut-Lock NI
32128-21	1	35	4	Nut-Flange Lock
32128-21	2	11	14	Nut-Flange Lock
32128-21	3	22	7	Nut-Flange Lock
32144-4	3	17	6	Screw-HH
32146-2	1	3	2	Nut-Lock NI
32151-29	1	12	2	Ring-External Snap



